

4N29X, 4N30X, 4N31X, 4N32X, 4N33X
4N29, 4N30, 4N31, 4N32, 4N33



**OPTICALLY COUPLED ISOLATOR
PHOTODARLINGTON OUTPUT**

'X' SPECIFICATION APPROVALS

- VDE 0884 in 3 available lead form :-
- STD
- G form
- SMD approved to CECC 0080

DESCRIPTION

The 4N29, 4N30, 4N31, 4N32, 4N33 series of optically coupled isolators consist of an infrared light emitting diode and NPN silicon photodarlington in a space efficient dual in line plastic package.

FEATURES

- Options :-
10mm lead spread - add G after part no.
Surface mount - add SM after part no.
Tape&reel - add SMT&R after part no.
- High Current Transfer Ratio
- High Isolation Voltage (5.3kV_{RMS}, 7.5kV_{PK})
- All electrical parameters 100% tested
- Custom electrical selections available

APPLICATIONS

- Computer terminals
- Industrial systems controllers
- Measuring instruments
- Signal transmission between systems of different potentials and impedances

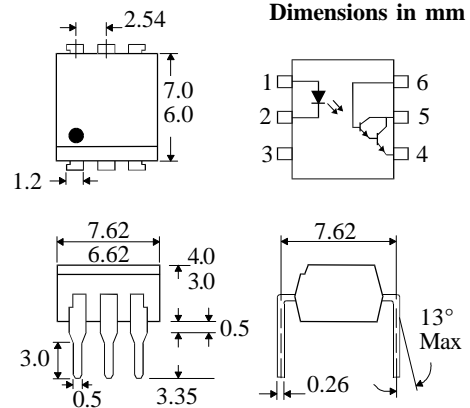

**ABSOLUTE MAXIMUM RATINGS
(25°C unless otherwise specified)**

Storage Temperature	-55°C to + 150°C
Operating Temperature	-55°C to + 100°C
Lead Soldering Temperature (1/16 inch (1.6mm) from case for 10 secs)	260°C

INPUT DIODE

Forward Current	80mA
Reverse Voltage	5V
Power Dissipation	105mW

OUTPUT TRANSISTOR

Collector-emitter Voltage BV _{CEO}	30V
Collector-base Voltage BV _{CBO}	50V
Emitter-collector Voltage BV _{ECO}	5V
Power Dissipation	150mW

POWER DISSIPATION

Total Power Dissipation	250mW
(derate linearly 3.3mW/°C above 25°C)	

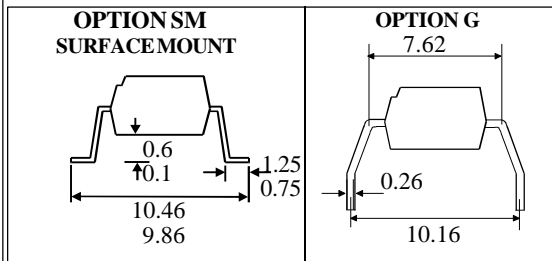

ISOCOM COMPONENTS LTD
Unit 25B, Park View Road West,
Park View Industrial Estate, Brenda Road
Hartlepool, TS25 1YD England Tel: (01429)863609
Fax: (01429) 863581 e-mail sales@isocom.co.uk
http://www.isocom.com

ISOCOM INC
1024 S. Greenville Ave, Suite 240,
Allen, TX 75002 USA
Tel: (214)495-0755 Fax: (214)495-0901
e-mail info@isocom.com
http://www.isocom.com

ELECTRICAL CHARACTERISTICS ($T_A = 25^\circ\text{C}$ Unless otherwise noted)

PARAMETER		MIN	TYP	MAX	UNITS	TEST CONDITION	
Input	Forward Voltage (V_F)		1.2	1.5	V	$I_F = 50\text{mA}$ $I_R = 10\mu\text{A}$ $V_R = 3\text{V}$	
	Reverse Voltage (V_R)	3			V		
	Reverse Current (I_R)			10	μA		
Output	Collector-emitter Breakdown (BV_{CEO})	30			V	$I_C = 1\text{mA}$ (note 2) $I_C = 100\mu\text{A}$ $I_E = 100\mu\text{A}$ $V_{CE} = 10\text{V}$	
	Collector-base Breakdown (BV_{CBO})	50			V		
	Emitter-collector Breakdown (BV_{ECO})	5			V		
	Collector-emitter Dark Current (I_{CEO})			100	nA		
Coupled	Collector Output Current (I_C) (Note 2)					$10\text{mA } I_F, 10\text{V } V_{CE}$ $10\text{mA } I_F, 10\text{V } V_{CE}$ $10\text{mA } I_F, 10\text{V } V_{CE}$	
	4N32, 4N33	50			mA		
	4N29, 4N30	10			mA		
	4N31	5			mA		
	Collector-emitter Saturation Voltage $V_{CE(SAT)}$						$8\text{mA } I_F, 2\text{mA } I_C$ $8\text{mA } I_F, 2\text{mA } I_C$
	4N29, 4N30, 4N32, 4N33			1.0	V		
	4N31			1.2	V		
	Input to Output Isolation Voltage V_{ISO}	5300					V_{RMS}
		7500					V_{PK}
	Input-output Isolation Resistance R_{ISO}	5×10^{10}					Ω
Output Turn on Time t_{on}			5	μs	$V_{CC} = 10\text{V}, I_C = 50\text{mA},$ $I_F = 200\text{mA},$ Pulse Width = 1ms fig.1		
Output Turn off Time t_{off}							
4N32, 4N33 t_{off}			100	μs			
4N29, 4N30, 4N31			40	μs			

Note 1 Measured with input leads shorted together and output leads shorted together.
 Note 2 Special Selections are available on request. Please consult the factory.

FIGURE 1

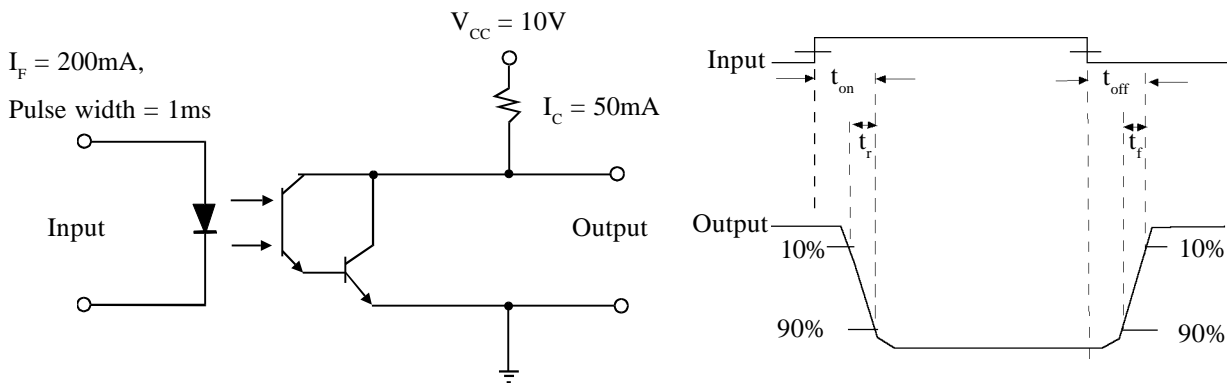

Collector Power Dissipation vs. Ambient Temperature

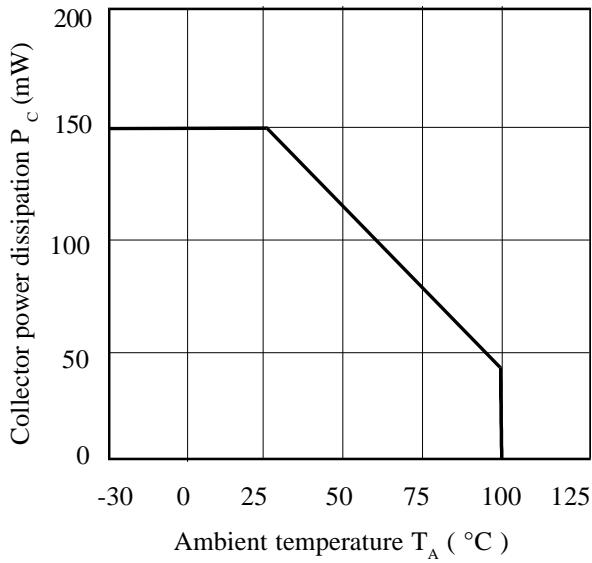

Current Transfer Ratio vs. Forward Current

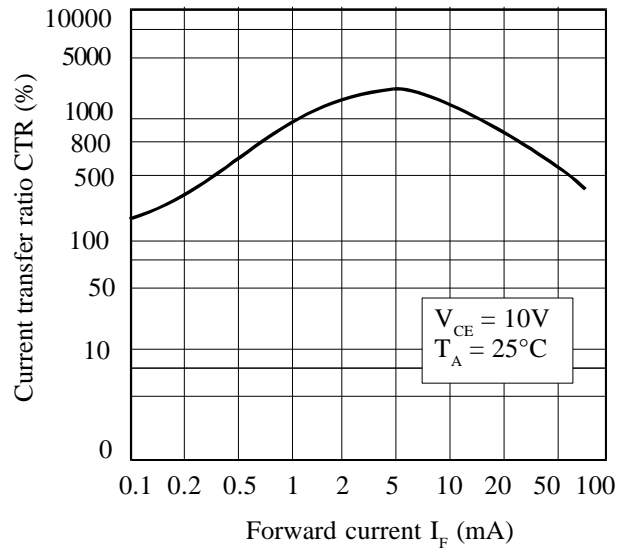

Forward Current vs. Ambient Temperature

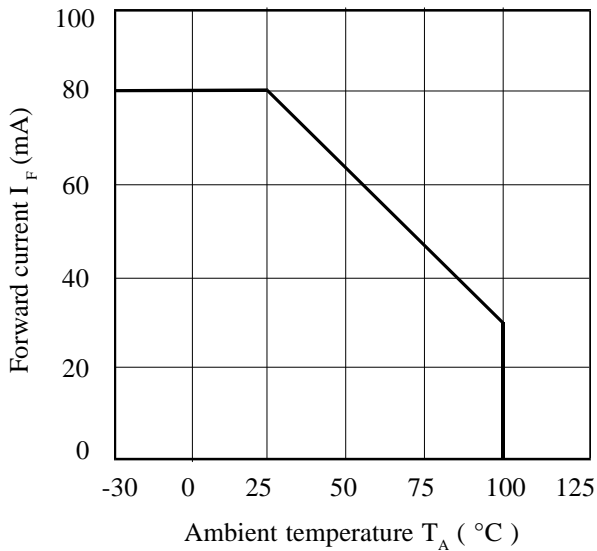

Collector Current vs. Collector-emitter Voltage

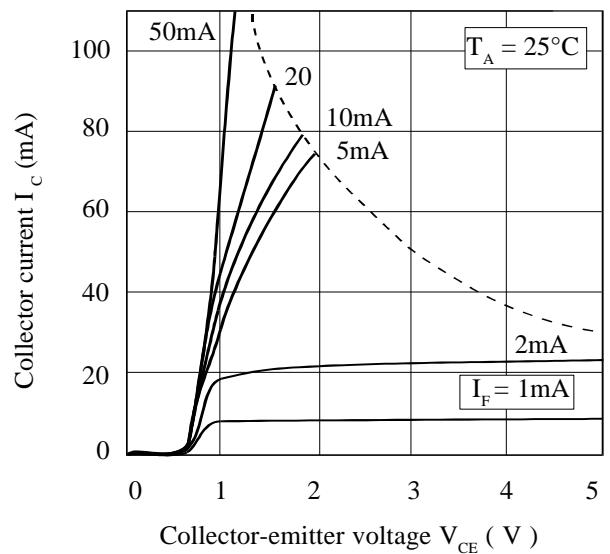

Collector-emitter Saturation Voltage vs. Ambient Temperature

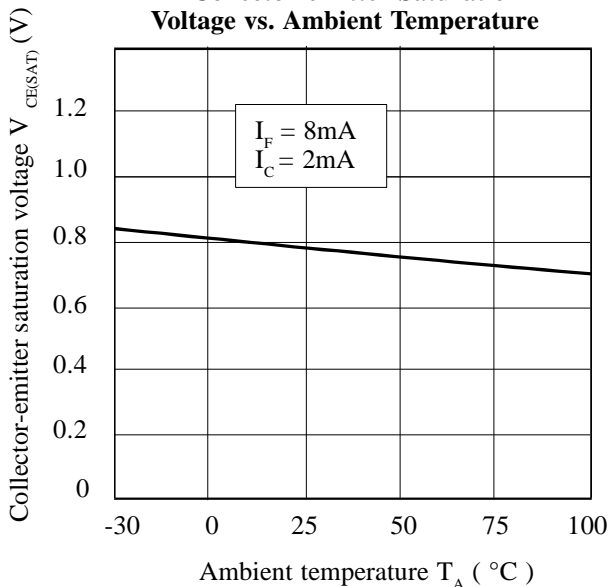

Relative Current Transfer Ratio vs. Ambient Temperature

