



website:<http://biz.LGservice.com>
e-mail:<http://www.LGservice.com/techsup.html>

LCD TV SERVICE MANUAL

CHASSIS : ML-012A

MODEL : RT-15LA31

CAUTION

BEFORE SERVICING THE CHASSIS,
READ THE SAFETY PRECAUTIONS IN THIS MANUAL.

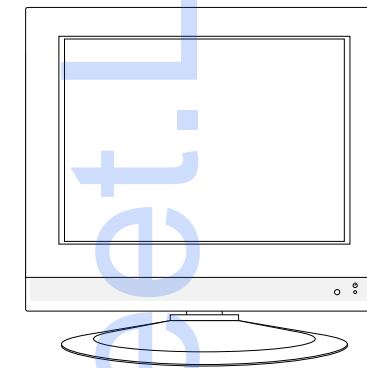

P/NO : 3828VD0108U

Jun., 2002
Printed in Korea

Dataset.Live

CONTENTS

Contents	2
Safety Precautions	3
Servicing Precautions	4
Description of Controls	6
Adjustment Instruction	9
Troubleshooting	15
Exploded View	16
Exploded View Parts List	17
Replacement Parts List	18
SVC. Sheet	

SAFETY PRECAUTIONS

IMPORTANT SAFETY NOTICE

Many electrical and mechanical parts in this chassis have special safety-related characteristics. These parts are identified by Δ in the Schematic Diagram and Replacement Parts List.

It is essential that these special safety parts should be replaced with the same components as recommended in this manual to prevent X-RADIATION, Shock, Fire, or other Hazards.

Do not modify the original design without permission of manufacturer.

General Guidance

An **Isolation Transformer should always be used** during the servicing of a receiver whose chassis is not isolated from the AC power line. Use a transformer of adequate power rating as this protects the technician from accidents resulting in personal injury from electrical shocks.

It will also protect the receiver and its components from being damaged by accidental shorts of the circuitry that may be inadvertently introduced during the service operation.

If any fuse (or Fusible Resistor) in this TV receiver is blown, replace it with the specified.

When replacing a high wattage resistor (Oxide Metal Film Resistor, over 1W), keep the resistor 10mm away from PCB.

Keep wires away from high voltage or high temperature parts.

Due to high vacuum and large surface area of picture tube, extreme care should be used in **handling the Picture Tube**. Do not lift the Picture tube by its Neck.

X-RAY Radiation

Warning:

The source of X-RAY RADIATION in this TV receiver is the High Voltage Section and the Picture Tube. For continued X-RAY RADIATION protection, the replacement tube must be the same type tube as specified in the Replacement Parts List.

To determine the presence of high voltage, use an accurate high impedance HV meter.

Adjust brightness, color, contrast controls to minimum.

Measure the high voltage.

The meter reading should indicate

23.5 \pm 1.5KV: 14-19 inch, 26 \pm 1.5KV: 19-21 inch,

29.0 \pm 1.5KV: 25-29 inch, 30.0 \pm 1.5KV: 32 inch

If the meter indication is out of tolerance, immediate service and correction is required to prevent the possibility of premature component failure.

Before returning the receiver to the customer,

always perform an **AC leakage current check** on the exposed metallic parts of the cabinet, such as antennas, terminals, etc., to be sure the set is safe to operate without damage of electrical shock.

Leakage Current Cold Check(Antenna Cold Check)

With the instrument AC plug removed from AC source, connect an electrical jumper across the two AC plug prongs. Place the AC switch in the on position, connect one lead of ohm-meter to the AC plug prongs tied together and touch other ohm-meter lead in turn to each exposed metallic parts such as antenna terminals, phone jacks, etc.

If the exposed metallic part has a return path to the chassis, the measured resistance should be between 1M Ω and 5.2M Ω .

When the exposed metal has no return path to the chassis the reading must be infinite.

An other abnormality exists that must be corrected before the receiver is returned to the customer.

Leakage Current Hot Check (See below Figure)

Plug the AC cord directly into the AC outlet.

Do not use a line Isolation Transformer during this check.

Connect 1.5K/10watt resistor in parallel with a 0.15 μ F capacitor between a known good earth ground (Water Pipe, Conduit, etc.) and the exposed metallic parts.

Measure the AC voltage across the resistor using AC voltmeter with 1000 ohms/volt or more sensitivity.

Reverse plug the AC cord into the AC outlet and repeat AC voltage measurements for each exposed metallic part. Any voltage measured must not exceed 0.75 volt RMS which is corresponds to 0.5mA.

In case any measurement is out of the limits specified, there is possibility of shock hazard and the set must be checked and repaired before it is returned to the customer.

Leakage Current Hot Check circuit

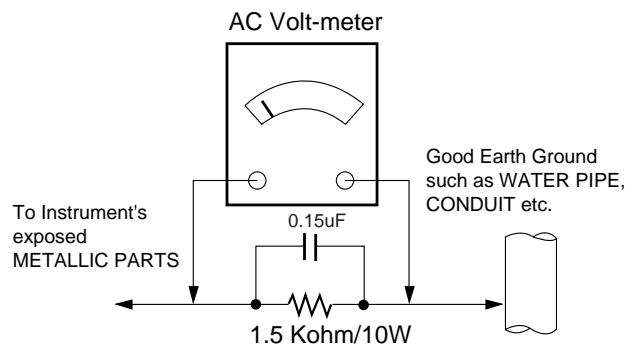

SERVICING PRECAUTIONS

CAUTION: Before servicing receivers covered by this service manual and its supplements and addenda, read and follow the **SAFETY PRECAUTIONS** on page 3 of this publication.

NOTE: If unforeseen circumstances create conflict between the following servicing precautions and any of the safety precautions on page 3 of this publication, always follow the safety precautions. Remember: Safety First.

General Servicing Precautions

1. Always unplug the receiver AC power cord from the AC power source before;
 - a. Removing or reinstalling any component, circuit board module or any other receiver assembly.
 - b. Disconnecting or reconnecting any receiver electrical plug or other electrical connection.
 - c. Connecting a test substitute in parallel with an electrolytic capacitor in the receiver.

CAUTION: A wrong part substitution or incorrect polarity installation of electrolytic capacitors may result in an explosion hazard.

- d. Discharging the picture tube anode.
2. Test high voltage only by measuring it with an appropriate high voltage meter or other voltage measuring device (DVM, FETVOM, etc) equipped with a suitable high voltage probe. Do not test high voltage by "drawing an arc".
 3. Discharge the picture tube anode only by (a) first connecting one end of an insulated clip lead to the degaussing or kine aquadag grounding system shield at the point where the picture tube socket ground lead is connected, and then (b) touch the other end of the insulated clip lead to the picture tube anode button, using an insulating handle to avoid personal contact with high voltage.
 4. Do not spray chemicals on or near this receiver or any of its assemblies.
 5. Unless specified otherwise in this service manual, clean electrical contacts only by applying the following mixture to the contacts with a pipe cleaner, cotton-tipped stick or comparable nonabrasive applicator; 10% (by volume) Acetone and 90% (by volume) isopropyl alcohol (90%-99% strength)

CAUTION: This is a flammable mixture.

Unless specified otherwise in this service manual, lubrication of contacts is not required.

6. Do not defeat any plug/socket B+ voltage interlocks with which receivers covered by this service manual might be equipped.
7. Do not apply AC power to this instrument and/or any of its electrical assemblies unless all solid-state device heat sinks are correctly installed.
8. Always connect the test receiver ground lead to the receiver chassis ground before connecting the test receiver positive lead.
Always remove the test receiver ground lead last.
9. *Use with this receiver only the test fixtures specified in this service manual.*

CAUTION: Do not connect the test fixture ground strap to any heatsink in this receiver.

Electrostatically Sensitive (ES) Devices

Some semiconductor (solid state) devices can be damaged easily by static electricity. Such components commonly are called *Electrostatically Sensitive (ES) Devices*. Examples of typical ES devices are integrated circuits and some field-effect

transistors and semiconductor "chip" components. The following techniques should be used to help reduce the incidence of component damage caused by static by static electricity.

1. Immediately before handling any semiconductor component or semiconductor-equipped assembly, drain off any electrostatic charge on your body by touching a known earth ground. Alternatively, obtain and wear a commercially available discharging wrist strap device, which should be removed to prevent potential shock reasons prior to applying power to the unit under test.
2. After removing an electrical assembly equipped with ES devices, place the assembly on a conductive surface such as aluminum foil, to prevent electrostatic charge buildup or exposure of the assembly.
3. Use only a grounded-tip soldering iron to solder or unsolder ES devices.
4. Use only an anti-static type solder removal device. Some solder removal devices not classified as "anti-static" can generate electrical charges sufficient to damage ES devices.
5. Do not use freon-propelled chemicals. These can generate electrical charges sufficient to damage ES devices.
6. Do not remove a replacement ES device from its protective package until immediately before you are ready to install it. (Most replacement ES devices are packaged with leads electrically shorted together by conductive foam, aluminum foil or comparable conductive material).
7. Immediately before removing the protective material from the leads of a replacement ES device, touch the protective material to the chassis or circuit assembly into which the device will be installed.

CAUTION: Be sure no power is applied to the chassis or circuit, and observe all other safety precautions.

8. Minimize bodily motions when handling unpackaged replacement ES devices. (Otherwise harmless motion such as the brushing together of your clothes fabric or the lifting of your foot from a carpeted floor can generate static electricity sufficient to damage an ES device.)

General Soldering Guidelines

1. Use a grounded-tip, low-wattage soldering iron and appropriate tip size and shape that will maintain tip temperature within the range of 500°F to 600°F.
 2. Use an appropriate gauge of RMA resin-core solder composed of 60 parts tin/40 parts lead.
 3. Keep the soldering iron tip clean and well tinned.
 4. Thoroughly clean the surfaces to be soldered. Use a mall wirebrush (0.5 inch, or 1.25cm) brush with a metal handle. Do not use freon-propelled spray-on cleaners.
 5. Use the following unsoldering technique
 - a. Allow the soldering iron tip to reach normal temperature. (500°F to 600°F)
 - b. Heat the component lead until the solder melts.
 - c. Quickly draw the melted solder with an anti-static, suction-type solder removal device or with solder braid.
- CAUTION:** Work quickly to avoid overheating the circuitboard printed foil.
6. Use the following soldering technique
 - a. Allow the soldering iron tip to reach a normal temperature (500°F to 600°F)
 - b. First, hold the soldering iron tip and solder the strand against the component lead until the solder melts.

- c. Quickly move the soldering iron tip to the junction of the component lead and the printed circuit foil, and hold it there only until the solder flows onto and around both the component lead and the foil.

CAUTION: Work quickly to avoid overheating the circuit board printed foil.

- d. Closely inspect the solder area and remove any excess or splashed solder with a small wire-bristle brush.

IC Remove/Replacement

Some chassis circuit boards have slotted holes (oblong) through which the IC leads are inserted and then bent flat against the circuit foil. When holes are the slotted type, the following technique should be used to remove and replace the IC. When working with boards using the familiar round hole, use the standard technique as outlined in paragraphs 5 and 6 above.

Removal

1. Desolder and straighten each IC lead in one operation by gently prying up on the lead with the soldering iron tip as the solder melts.
2. Draw away the melted solder with an anti-static suction-type solder removal device (or with solder braid) before removing the IC.

Replacement

1. Carefully insert the replacement IC in the circuit board.
2. Carefully bend each IC lead against the circuit foil pad and solder it.
3. Clean the soldered areas with a small wire-bristle brush. (It is not necessary to reapply acrylic coating to the areas).

"Small-Signal" Discrete Transistor

Removal/Replacement

1. Remove the defective transistor by clipping its leads as close as possible to the component body.
2. Bend into a "U" shape the end of each of three leads remaining on the circuit board.
3. Bend into a "U" shape the replacement transistor leads.
4. Connect the replacement transistor leads to the corresponding leads extending from the circuit board and crimp the "U" with long nose pliers to insure metal to metal contact then solder each connection.

Power Output, Transistor Device

Removal/Replacement

1. Heat and remove all solder from around the transistor leads.
2. Remove the heatsink mounting screw (if so equipped).
3. Carefully remove the transistor from the heat sink of the circuit board.
4. Insert new transistor in the circuit board.
5. Solder each transistor lead, and clip off excess lead.
6. Replace heatsink.

Diode Removal/Replacement

1. Remove defective diode by clipping its leads as close as possible to diode body.
2. Bend the two remaining leads perpendicular to the circuit board.
3. Observing diode polarity, wrap each lead of the new diode around the corresponding lead on the circuit board.
4. Securely crimp each connection and solder it.
5. Inspect (on the circuit board copper side) the solder joints of the two "original" leads. If they are not shiny, reheat them and if necessary, apply additional solder.

Fuse and Conventional Resistor

Removal/Replacement

1. Clip each fuse or resistor lead at top of the circuit board hollow stake.
2. Securely crimp the leads of replacement component around notch at stake top.
3. Solder the connections.

CAUTION: Maintain original spacing between the replaced component and adjacent components and the circuit board to prevent excessive component temperatures.

Circuit Board Foil Repair

Excessive heat applied to the copper foil of any printed circuit board will weaken the adhesive that bonds the foil to the circuit board causing the foil to separate from or "lift-off" the board. The following guidelines and procedures should be followed whenever this condition is encountered.

At IC Connections

To repair a defective copper pattern at IC connections use the following procedure to install a jumper wire on the copper pattern side of the circuit board. (Use this technique only on IC connections).

1. Carefully remove the damaged copper pattern with a sharp knife. (Remove only as much copper as absolutely necessary).
2. Carefully scratch away the solder resist and acrylic coating (if used) from the end of the remaining copper pattern.
3. Bend a small "U" in one end of a small gauge jumper wire and carefully crimp it around the IC pin. Solder the IC connection.
4. Route the jumper wire along the path of the out-away copper pattern and let it overlap the previously scraped end of the good copper pattern. Solder the overlapped area and clip off any excess jumper wire.

At Other Connections

Use the following technique to repair the defective copper pattern at connections other than IC Pins. This technique involves the installation of a jumper wire on the component side of the circuit board.

1. Remove the defective copper pattern with a sharp knife. Remove at least 1/4 inch of copper, to ensure that a hazardous condition will not exist if the jumper wire opens.
 2. Trace along the copper pattern from both sides of the pattern break and locate the nearest component that is directly connected to the affected copper pattern.
 3. Connect insulated 20-gauge jumper wire from the lead of the nearest component on one side of the pattern break to the lead of the nearest component on the other side. Carefully crimp and solder the connections.
- CAUTION:** Be sure the insulated jumper wire is dressed so the it does not touch components or sharp edges.

DESCRIPTION OF CONTROLS

All the functions can be controlled with the remote control handset. Some functions can also be adjusted with the buttons on the side panel of the set.

Remote control handset

Before you use the remote control handset, please install the batteries. See the next page.

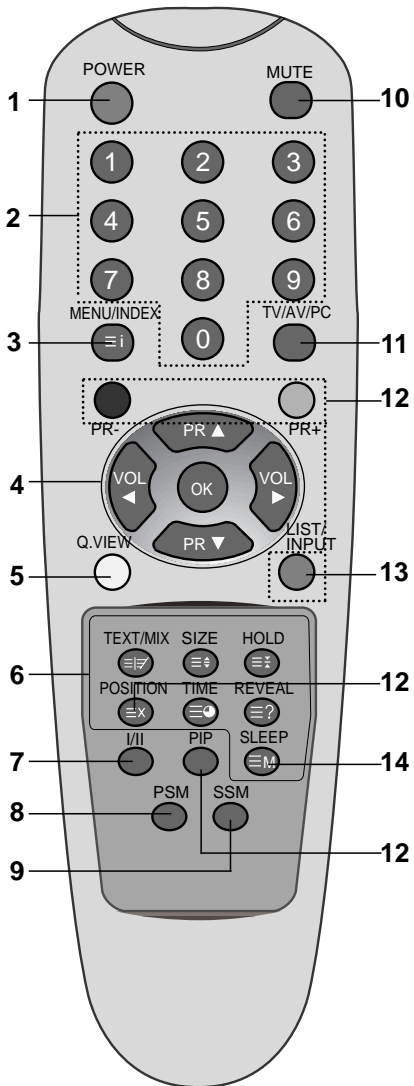

1. **POWER**
switches the set on from standby or off to standby.
2. **NUMBER BUTTONS**
switches the set on from standby and selects a programme.
3. **MENU (or INDEX)**
selects a menu.
selects an index page in the teletext mode (only TELETEXT models).
4. **▲ / ▼ (Programme Up/Down)**
selects a programme or a menu item.
- ◀ / ▶ (Volume Up/Down)**
adjusts the volume.
- OK**
accepts your selection or displays the current mode.
5. **Q.VIEW**
returns to the previously viewed programme.
6. **TELETEXT BUTTONS (option)**
These buttons are used for teletext.
For further details, see the 'Teletext' section.
7. **I/II (option)**
selects the language during dual language broadcast.
selects the sound output (option).
8. **PSM (Picture Status Memory)**
recalls your preferred picture setting.
9. **SSM (Sound Status Memory)**
recalls your preferred sound setting.

10. MUTE

switches the sound on or off.

11. TV/AV/PC

selects TV, AV or PC monitor mode.
clears the menu from the screen.
switches the set on from standby.

12. PIP BUTTONS (option) (PC mode only)

PIP

switches the sub picture on or off.

PR +/-

selects a programme for the sub picture.

INPUT

selects the input mode for the sub picture.

POSITION

relocates the sub picture in up/down or left/right direction.

13. LIST

displays the programme table.

14. SLEEP

sets the sleep timer.

Note : In teletext mode, the **PR+/-**, **Q.VIEW** and **LIST** buttons are used for teletext functions.

Battery installation

The remote control handset is powered by two AAA type batteries. To load the batteries, turn the remote control handset over and open the battery compartment. Install two batteries as indicated by the polarity symbols (+ and -) marked inside the compartment.

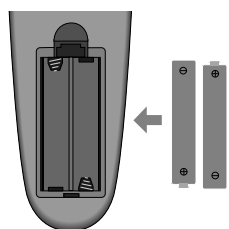

Note : To avoid damage from possible battery leakage, remove the batteries if you do not plan to use the remote control handset for an extended period of time.

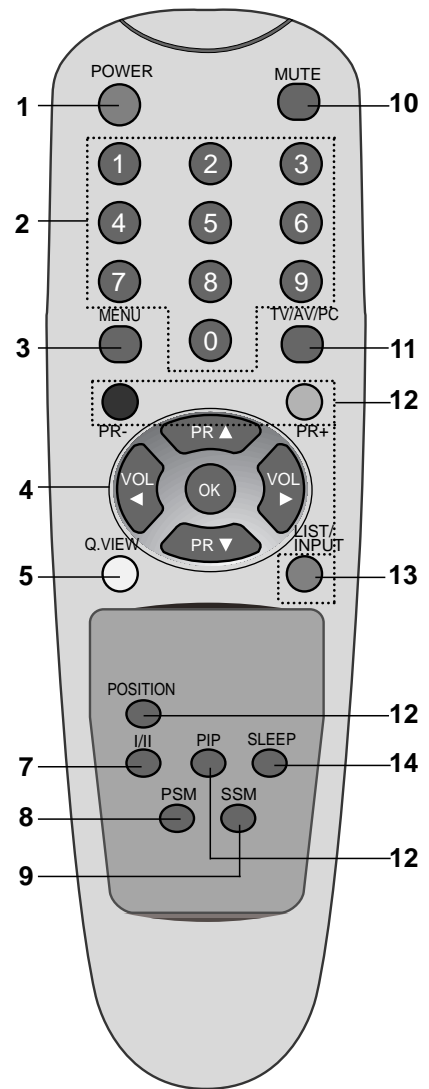

Side panel

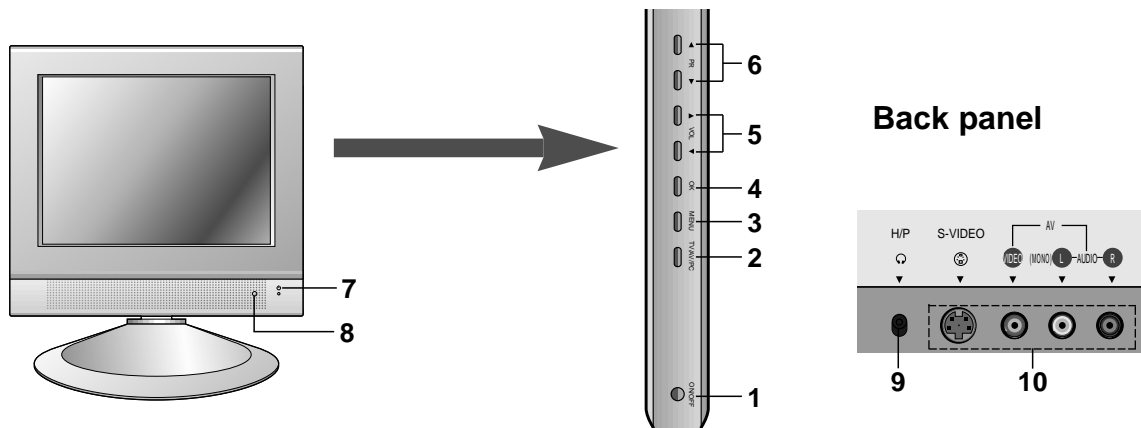

1. **MAIN POWER (ON/OFF)**
switches the set on or off.
 2. **TV/AV/PC**
selects TV, DVD, AV or PC monitor mode.
clears the menu from the screen.
switches the set on from standby.
 3. **MENU**
selects a menu.
 4. **OK**
accepts your selection or displays the current mode.
 5. **◀ / ▶ (Volume Up/Down)**
adjusts the volume.
adjusts menu settings.
 6. **▲ / ▼ (Programme Up/Down)**
selects a programme or a menu item.
switches the set on from standby.
 7. **POWER/STANDBY INDICATOR (Ⓞ)**
illuminates brightly when the set is in standby mode.
dims when the set is switched on.
 8. **REMOTE CONTROL SENSOR**
 9. **HEADPHONE SOCKET**
Connect the headphone plug to this socket.
 10. **AUDIO/VIDEO IN SOCKETS (AV)**
Connect the audio/video out sockets of external equipment to these sockets.
- S-VIDEO/AUDIO IN SOCKETS (S-Video)**
Connect the video out socket of an S-VIDEO VCR to the **S-VIDEO** socket.
Connects the audio out sockets of the S-VIDEO VCR to the audio sockets as in **AV**.

ADJUSTMENT INSTRUCTION

1. Application Object

This instruction is for the application to the LCD TV.

2. Notes

- (1) This set uses an adapter, so connect the adapter and the set correctly before adjustment.
 - (2) The adjustment must be performed under the correct sequence.
 - (3) The adjustment must be performed in the circumstance of $25\pm 5^{\circ}\text{C}$ of temperature and $65\pm 10\%$ of relative humidity if there is no specific designation.
 - (4) The input voltage of the receiver must keep 100~220V, 50/60Hz in adjusting.
 - (5) The set must be operated for 30 minutes preliminarily before adjustment if there is no specific designation.
- * 'Heat Run' must be performed with the full white signal or TV noise signal in the internal part of the set.
- * The time for 'Heat Run' can be changed owing to production plan.

3. PC Input Mode Adjustment

3-1. Required Test Equipment

- (1) A pattern generator being in proportion to VG819 ; Pattern of 11 tones
- (2) A Service remote control

3-2. Preparation for Adjustment

- (1) Perform 'Heat Run' for more than 30 minutes in white pattern.
- (2) Connect the signal of pattern generator with LCD TV.
- (3) Apply the gray signal of XGA(1024X768) 11 tones by using VG819.
- (4) In VSC mode, adjust the Auto gay from 0 to 1 by using Vol(+) button.

3-3. Position of Mode Adjustment

Timing of Mode Table

* H[dot]/V[line]

Mode	VGA-60	VGA-67	VGA-72	VGA-75	VGA-85	SVGA-56	SVGA-60	SVGA-72	SVGA-75
H_Total	800	864	832	840	832	1024	1056	1040	1056
H_Display	640	640	656	640	640	800	800	800	800
H_Blanking	160	224	176	200	192	224	256	240	256
H_Sync	96	64	40	64	56	72	128	120	80
H Polarity	NEG.	NEG.	NEG.	NEG.	NEG.	POS	POS	POS	POS
H_Bp	48	96	120	120	80	128	88	64	160
H_Fp	16	64	16	16	56	24	40	56	16
H-Freq[KHz]	31.469	35.0	37.861	37.5	43.269	35.156	37.879	48.077	46.875
/Clk[MHz]	25.175	30.24	31.5	31.5	36.0	36.0	40.0	50.0	49.5
V_Total	525	525	520	500	509	625	628	666	625
V_Display	480	480	496	480	480	600	600	600	600
V_Blanking	45	45	24	20	29	25	28	66	25
V_Sync	2	3	3	3	3	2	4	6	3
V Polarity	NEG	NEG	NEG	NEG	NEG	POS	POS	POS	POS
V_Bp	33	39	20	16	25	22	23	23	21
V_Fp	10	3	1	1	1	1	1	37	1

Mode	SVGA-85	XGA-60	XGA-70	XGA-75	MAC-75	XGA-85	VGA350-70	VGA350-85	VGA400-70	VGA400-85
H_Total	1048	1344	1328	1312	1152	1376	800	832	800	832
H_Display	800	1024	1024	1024	832	1024	640	640	640	640
H_Blanking	248	320	304	288	320	352	160	192	160	192
H_Sync	64	136	136	96	64	96	96	64	96	64
H Polarity	POS	NEG	NEG	POS	NEG	POS	POS	POG	NEG	NEG
H_Bp	152	136	144	176	224	208	48	96	48	96
H_Fp	32	160	24	16	32	48	16	32	16	32
H-Freq[KHz]	53.674	48.363	56.476	60.23	49.725	68.677	31.468	37.86	31.46	37.86
/Clk[MHz]	56.25	65.0	75.0	78.75	57.283	84.997	25.17	31.47	25.17	31.5
V_Total	631	806	806	800	667	808	449	445	449	445
V_Display	600	768	768	768	624	768	350	350	400	400
V_Blanking	31	38	38	32	43	40	99	95	49	45
V_Sync	3	6	6	3	3	3	2	3	2	3
V Polarity	POS	NEG	NEG	POS	NWG	POS	NEG	NEG	POS	POS
V_Bp	27	29	29	28	39	36	60	60	35	41
V_Fp	1	3	3	1	1	1	37	32	12	1

4. EDID(The Extended Display Identification Data)

EDID Table

	00	01	02	03	04	05	06	07	08	09	0A	0B	0C	0D	0E	0F
00	00	FF	FF	FF	FF	FF	FF	00	30	E5	D7	3A	01	00	00	00
10	00	0B	01	01	78	1F	17	70	E8	C3	A0	A3	54	4C	97	24
20	14	50	54	BF	E8	80	31	59	3B	D9	45	59	61	59	71	59
30	81	40	81	80	01	01	10	0E	01	01	01	01	01	01	01	01
40	01	01	01	01	01	01	01	01	F9	15	01	01	01	01	01	01
50	01	01	01	01	01	01	01	01	01	01	64	19	00	40	41	00
60	26	30	18	88	36	00	0E	C3	10	00	00	1E	00	00	00	FD
70	00	32	55	1E	46	0D	00	0A	20	20	20	20	20	20	00	C8

5. Option1 data(200PR~A2 ST:1bit,SYS:2bit)

OPTION Data	200PR	TEXT	I/II SV	TOP	SCART	A2 ST	SYS
0	0	0	0	0	0	0	0
1	0	0	0	0	0	0	1
2	0	0	0	0	0	0	2
3	0	0	0	0	0	0	3
4	0	0	0	0	0	1	0
5	0	0	0	0	0	1	1
6	0	0	0	0	0	1	2
7	0	0	0	0	0	1	3
8	0	0	0	0	1	0	0
9	0	0	0	0	1	0	1
10	0	0	0	0	1	0	2
11	0	0	0	0	1	0	3
12	0	0	0	0	1	1	0
13	0	0	0	0	1	1	1
14	0	0	0	0	1	1	2
15	0	0	0	0	1	1	3
16	0	0	0	1	0	0	0
17	0	0	0	1	0	0	1
18	0	0	0	1	0	0	2
19	0	0	0	1	0	0	3
20	0	0	0	1	0	1	0
21	0	0	0	1	0	1	1
22	0	0	0	1	0	1	2
23	0	0	0	1	0	1	3
24	0	0	0	1	1	0	0
25	0	0	0	1	1	0	1
26	0	0	0	1	1	0	2
27	0	0	0	1	1	0	3
28	0	0	0	1	1	1	0
29	0	0	0	1	1	1	1
30	0	0	0	1	1	1	2
31	0	0	0	1	1	1	3

OPTION Data	200PR	TEXT	I/II SV	TOP	SCART	A2 ST	SYS
32	0	0	1	0	0	0	0
33	0	0	1	0	0	0	1
34	0	0	1	0	0	0	2
35	0	0	1	0	0	0	3
36	0	0	1	0	0	1	0
37	0	0	1	0	0	1	1
38	0	0	1	0	0	1	2
39	0	0	1	0	0	1	3
40	0	0	1	0	1	0	0
41	0	0	1	0	1	0	1
42	0	0	1	0	1	0	2
43	0	0	1	0	1	0	3
44	0	0	1	0	1	1	0
45	0	0	1	0	1	1	1
46	0	0	1	0	1	1	2
47	0	0	1	0	1	1	3
48	0	0	1	1	0	0	0
49	0	0	1	1	0	0	1
50	0	0	1	1	0	0	2
51	0	0	1	1	0	0	3
52	0	0	1	1	0	1	0
53	0	0	1	1	0	1	1
54	0	0	1	1	0	1	2
55	0	0	1	1	0	1	3
56	0	0	1	1	1	0	0
57	0	0	1	1	1	0	1
58	0	0	1	1	1	0	2
59	0	0	1	1	1	0	3
60	0	0	1	1	1	1	0
61	0	0	1	1	1	1	1
62	0	0	1	1	1	1	2
63	0	0	1	1	1	1	3

OPTION Data	200PR	TEXT	I/II SV	TOP	SCART	A2 ST	SYS
64	0	1	0	0	0	0	0
65	0	1	0	0	0	0	1
66	0	1	0	0	0	0	2
67	0	1	0	0	0	0	3
68	0	1	0	0	0	1	0
69	0	1	0	0	0	1	1
70	0	1	0	0	0	1	2
71	0	1	0	0	0	1	3
72	0	1	0	0	1	0	0
73	0	1	0	0	1	0	1
74	0	1	0	0	1	0	2
75	0	1	0	0	1	0	3
76	0	1	0	0	1	1	0
77	0	1	0	0	1	1	1
78	0	1	0	0	1	1	2
79	0	1	0	0	1	1	3
80	0	1	0	1	0	0	0
81	0	1	0	1	0	0	1
82	0	1	0	1	0	0	2
83	0	1	0	1	0	0	3
84	0	1	0	1	0	1	0
85	0	1	0	1	0	1	1
86	0	1	0	1	0	1	2
87	0	1	0	1	0	1	3
88	0	1	0	1	1	0	0
89	0	1	0	1	1	0	1
90	0	1	0	1	1	0	2
91	0	1	0	1	1	0	3
92	0	1	0	1	1	1	0
93	0	1	0	1	1	1	1
94	0	1	0	1	1	1	2
95	0	1	0	1	1	1	3
96	0	1	1	0	0	0	0
97	0	1	1	0	0	0	1
98	0	1	1	0	0	0	2
99	0	1	1	0	0	0	3
100	0	1	1	0	0	1	0
101	0	1	1	0	0	1	1
102	0	1	1	0	0	1	2
103	0	1	1	0	0	1	3
104	0	1	1	0	1	0	0
105	0	1	1	0	1	0	1
106	0	1	1	0	1	0	2
107	0	1	1	0	1	0	3
108	0	1	1	0	1	1	0
109	0	1	1	0	1	1	1

OPTION Data	200PR	TEXT	I/II SV	TOP	SCART	A2 ST	SYS
110	0	1	1	0	1	1	2
111	0	1	1	0	1	1	3
112	0	1	1	1	0	0	0
113	0	1	1	1	0	0	1
114	0	1	1	1	0	0	2
115	0	1	1	1	0	0	3
116	0	1	1	1	0	1	0
117	0	1	1	1	0	1	1
118	0	1	1	1	0	1	2
119	0	1	1	1	0	1	3
120	0	1	1	1	1	0	0
121	0	1	1	1	1	0	1
122	0	1	1	1	1	0	2
123	0	1	1	1	1	0	3
124	0	1	1	1	1	1	0
125	0	1	1	1	1	1	1
126	0	1	1	1	1	1	2
127	0	1	1	1	1	1	3
128	1	0	0	0	0	0	0
129	1	0	0	0	0	0	1
130	1	0	0	0	0	0	2
131	1	0	0	0	0	0	3
132	1	0	0	0	0	1	0
133	1	0	0	0	0	1	1
134	1	0	0	0	0	1	2
135	1	0	0	0	0	1	3
136	1	0	0	0	1	0	0
137	1	0	0	0	1	0	1
138	1	0	0	0	1	0	2
139	1	0	0	0	1	0	3
140	1	0	0	0	1	1	0
141	1	0	0	0	1	1	1
142	1	0	0	0	1	1	2
143	1	0	0	0	1	1	3
144	1	0	0	1	0	0	0
145	1	0	0	1	0	0	1
146	1	0	0	1	0	0	2
147	1	0	0	1	0	0	3
148	1	0	0	1	0	1	0
149	1	0	0	1	0	1	1
150	1	0	0	1	0	1	2
151	1	0	0	1	0	1	3
152	1	0	0	1	1	0	0
153	1	0	0	1	1	0	1
154	1	0	0	1	1	0	2
155	1	0	0	1	1	0	3

OPTION Data	200PR	TEXT	/III SV	TOP	SCART	A2 ST	SYS
156	1	0	0	1	1	1	0
157	1	0	0	1	1	1	1
158	1	0	0	1	1	1	2
159	1	0	0	1	1	1	3
160	1	0	1	0	0	0	0
161	1	0	1	0	0	0	1
162	1	0	1	0	0	0	2
163	1	0	1	0	0	0	3
164	1	0	1	0	0	1	0
165	1	0	1	0	0	1	1
166	1	0	1	0	0	1	2
167	1	0	1	0	0	1	3
168	1	0	1	0	1	0	0
169	1	0	1	0	1	0	1
170	1	0	1	0	1	0	2
171	1	0	1	0	1	0	3
172	1	0	1	0	1	1	0
173	1	0	1	0	1	1	1
174	1	0	1	0	1	1	2
175	1	0	1	0	1	1	3
176	1	0	1	1	0	0	0
177	1	0	1	1	0	0	1
178	1	0	1	1	0	0	2
179	1	0	1	1	0	0	3
180	1	0	1	1	0	1	0
181	1	0	1	1	0	1	1
182	1	0	1	1	0	1	2
183	1	0	1	1	0	1	3
184	1	0	1	1	1	0	0
185	1	0	1	1	1	0	1
186	1	0	1	1	1	0	2
187	1	0	1	1	1	0	3
188	1	0	1	1	1	1	0
189	1	0	1	1	1	1	1
190	1	0	1	1	1	1	2
191	1	0	1	1	1	1	3
192	1	1	0	0	0	0	0
193	1	1	0	0	0	0	1
194	1	1	0	0	0	0	2
195	1	1	0	0	0	0	3
196	1	1	0	0	0	1	0
197	1	1	0	0	0	1	1
198	1	1	0	0	0	1	2
199	1	1	0	0	0	1	3
200	1	1	0	0	1	0	0
201	1	1	0	0	1	0	1

OPTION Data	200PR	TEXT	/III SV	TOP	SCART	A2 ST	SYS
202	01	1	0	0	1	0	2
203	1	1	0	0	1	0	3
204	1	1	0	0	1	1	0
205	1	1	0	0	1	1	1
206	1	1	0	0	1	1	2
207	1	1	0	0	1	1	3
208	1	1	0	1	0	0	0
209	1	1	0	1	0	0	1
210	1	1	0	1	0	0	2
211	1	1	0	1	0	0	3
212	1	1	0	1	0	1	0
213	1	1	0	1	0	1	1
214	1	1	0	1	0	1	2
215	1	1	0	1	0	1	3
216	1	1	0	1	1	0	0
217	1	1	0	1	1	0	1
218	1	1	0	1	1	0	2
219	1	1	0	1	1	0	3
220	1	1	0	1	1	1	0
221	1	1	0	1	1	1	1
222	1	1	0	1	1	1	2
223	1	1	0	1	1	1	3
224	1	1	1	0	0	0	0
225	1	1	1	0	0	0	1
226	1	1	1	0	0	0	2
227	1	1	1	0	0	0	3
228	1	1	1	0	0	1	0
229	1	1	1	0	0	1	1
230	1	1	1	0	0	1	2
231	1	1	1	0	0	1	3
232	1	1	1	0	1	0	0
233	1	1	1	0	1	0	1
234	1	1	1	0	1	0	2
235	1	1	1	0	1	0	3
236	1	1	1	0	1	1	0
237	1	1	1	0	1	1	1
238	1	1	1	0	1	1	2
239	1	1	1	0	1	1	3
240	1	1	1	1	0	0	0
241	1	1	1	1	0	0	1
242	1	1	1	1	0	0	2
243	1	1	1	1	0	0	3
244	1	1	1	1	0	1	0
245	1	1	1	1	0	1	1
246	1	1	1	1	0	1	2
247	1	1	1	1	0	1	3

OPTION Data	200PR	TEXT	I/II SV	TOP	SCART	A2 ST	SYS
248	1	1	1	1	1	0	0
249	1	1	1	1	1	0	1
250	1	1	1	1	1	0	2
251	1	1	1	1	1	0	3
252	1	1	1	1	1	1	0
253	1	1	1	1	1	1	1
254	1	1	1	1	1	1	2
255	1	1	1	1	1	1	3

6. Option2 data(ACMS~BBACK:1bit,LANG:3bit)

OPTION Data	ACMS	VOL	HIDEV
0	0	0	0
1	0	0	1
2	0	1	0
3	0	1	1
4	1	0	0
5	1	0	1
6	1	1	0
7	1	1	1

7. Option3 data(IIC AFT~CH+AU:1bit)

OPTION Data	IIC AFT	MD SAVE	MONO	CH+AUS
0	0	0	0	0
1	0	0	0	1
2	0	0	1	0
3	0	0	1	1
4	0	1	0	0
5	0	1	0	1
6	0	1	1	0
7	0	1	1	1
8	1	0	0	0
9	1	0	0	1
10	1	0	1	0
11	1	0	1	1
12	1	1	0	0
13	1	1	0	1
14	1	1	1	0
15	1	1	1	1

TROUBLESHOOTING

1. General Features

No.	Symptom	Cause	Check Point
1	Soft touch doesn't function properly	Defective speaker wire and inverter wire	1) Make some space between the speaker wire and the Soft touch Board by sticking the speaker wire to the guide hole of the cabinet. 2) Arrange working state of A1. correct working state of the Shield case.
2	Soft touch doesn't function	1) Broken components and soldering of them 2) P2 connector error	1) Check Soft touch with eyes Check and repair soldering 2) Check and repair the P2 connector
3	No screen	Input error of inverter connector	1) Bend the pin legs of P1 connector -> recheck them 2) Check and repair the IC804,805 SI4925
		P502 and Pin 21 connector being slipped out	1) Check and fix P902 connector 2) Check and fix the components at P902 LCD module and at main board. 3) Check Pin21.
		Cracked components and soldering at tuner board	1) Check and repair tuner board and main board 2) Solder Q101,102.
4	Dark screen	1) Defective LCD lamp 2) Defective inverter 3) Input error of inverter connector	1) Replace the inverter 2) Replace the LCD lamp 2) Check the connector input.

2. PC Mode

No.	Symptom	Cause	Check Point
5	Screen noise	Clock or phase being not able to be adjusted	1) Resettig is needed according to the video card of each PC 2) Horizontal noise : adjust phase until no horizontal noise occurs 3) Vertical noise : adjust clock in menu until no vertical noise occurs
6	Screen position error	Screen position error horizontally or vertically	1) Play the Auto Configure in Menu. 2) Adjust horizontal and vertical position until the screen displays normally
7	Color beat noise	Soldering D-SUB Jack of JA202 and IC202.	Recheck and repair JA202,IC202

3. TV and external input

No.	Symptom	Cause	Check Point
8	No sound - Speaker - Earphone	Defective Reset IC of IC603 Defective MSP340D of IC601 Defective B+(8V,5V) of IC604,605.	1) Check volume and speaker - Sound comes out only when being inputted into Audio L/R 2) Check after replacing IC603 3) Replace IC601 4) Check and replace B+ of IC604,605.
9	Video color beat noise	Earphone shield case being touched	Check the mould of shield and JA203, Replace shield case
		Soldering IC301 and IC912	Re-soldering

EXPLODED VIEW

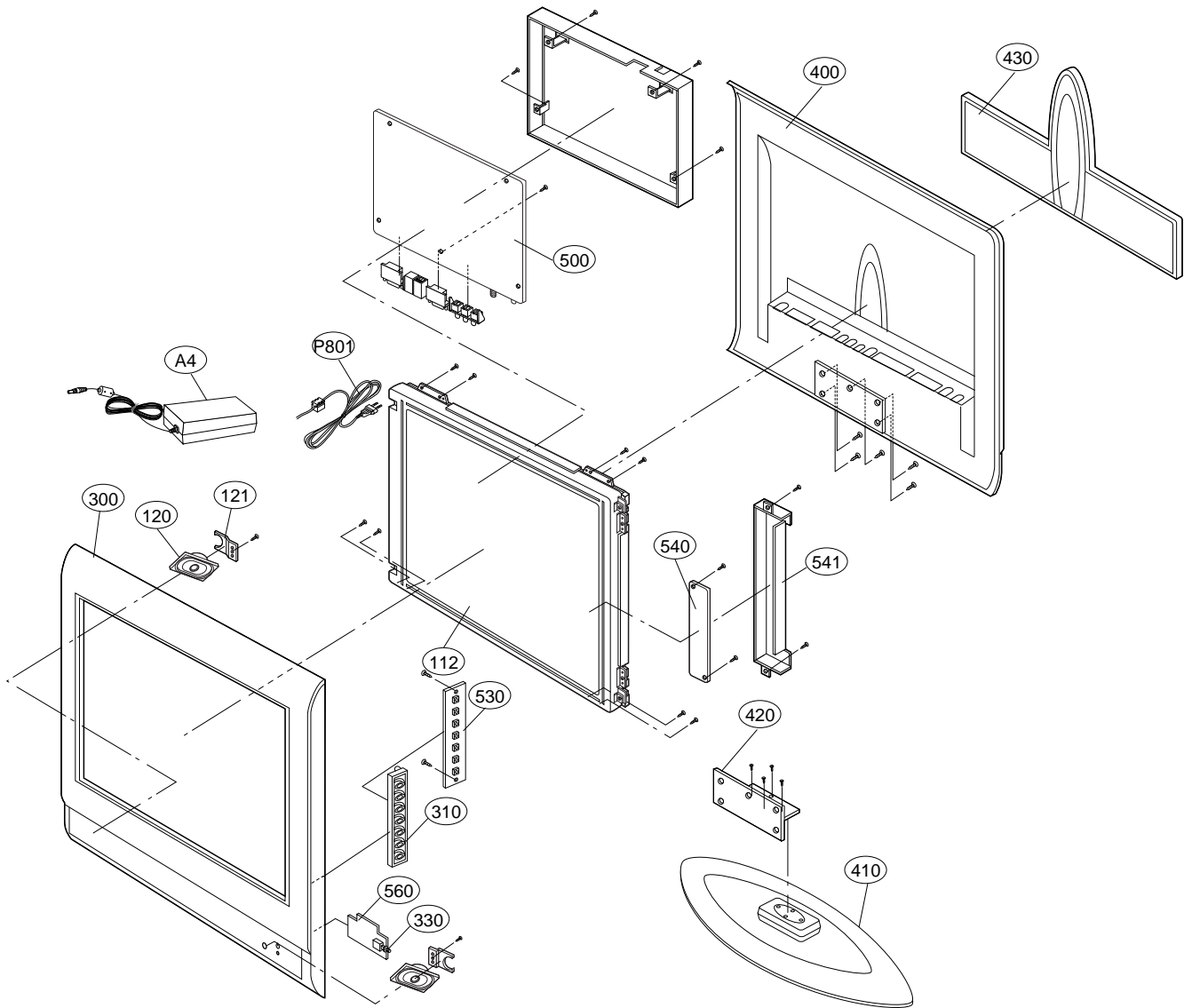

EXPLODED VIEW PARTS LIST

No.	PART NO.	DESCRIPTION
112	6304FLP006B	LCD LC151X01-C3P1 LG PHILPS TFT CO
120	6400VA0017A	SPEAKER,GENERAL LG C&D 8 OHM 1.0
121	4950V00067A	METAL,SPEAKER HOLDER (L,R)
300	3091V00A15L	CABINET ASSY LG FLATRON .
310	5020V00552F	BUTTON
330	5020V00553D	BUTTON,POWER
400	3809V00273X	BACK COVER ASSY PHONE
410	4811V00015A	BRACKET ASSY,MAIN
420	4950V00063B	METAL,HINGE FIXER SUS304 15LA30
430	3581V00033A	DOOR ASSEMBLY
500	3141VMNC22C	CHASSIS ASSY,MAIN ML012A
	3141VMNC22D	CHASSIS ASSY,MAIN ML012A
530	6871VSMA12A	PWB(PCB) ASSY,CTL ASSY RT-15LA3
540	6633VA0003K	INVERTER ASSY 12VOLT VOLT ECT ALPS4LAMP
541	4814V00228A	SHIELD,CASE INVERTER ET-C 32X203 400
560	6871VSMA13F	PWB ASSY,POWER ML012A RT-15LA31
P801	6410VEH003A	POWER,CORD

REPLACEMENT PARTS LIST

For Capacitor & Resistors, the characters at 2nd and 3rd digit in the P/No. means as follows;	CC, CX, CK, CN : Ceramic CQ : Polyester CE : Electrolytic	RD : Carbon Film RS : Metal Oxide Film RN : Metal Film RF : Fusible
---	---	--

LOCA. NO	PART NO	DESCRIPTION
IC		
IC1	0IZZVC0042C	IC,SDA555XFL 52P,DIP ST ML012A
IC2	0IAL241610B	IC,AT24C16-10PC-2.7 8PIN DIP ST E
IC3	0IFA752700A	IC,KA75270Z 3 TP RE-SET IC MC-007
IC4	0IMCRNS002A	IC,LM1881M NATIONAL SEMICONDUCTOR
IC201	0IAL242110A	IC,AT24C21-10SI-2.5 8P,SOP TP 1K
IC202	0IPH740800M	IC,74F08D 14P SOIC R/TP QUAD 2-IN
IC301	0IIT323000D	IC,VPC3230D QA B4 80P QFP TRAY SO
IC302	0IHY100100A	IC,LGTV1001 64P QFP BK PROGRESSIV
IC601	0IMCRMN011B	IC,MSP3410G QA B8 MICRONAS 80P QF
IC602	0ISA428200A	IC,LA4282 12S 2CHX10W AUDIO AMP
IC603	0IKE704200J	IC,KIA7042AF SOT-89 TP 4.2V VOLTA
IC604	0IMCRFA009A	IC,KA78M08RTM, FAIRCHILD 2P D-PAK
IC605	0IMCRFA008A	IC,KA78M05RTM, FAIRCHILD 2P D-PAK
IC801	0ITC786000A	IC,SI786 28SSOP TP DUAL-OUTPUT PO
IC901	0IMCRG2004B	IC,JAGASM A4 SAGE 352BALL TRAY HI
IC902	0IPH806520A	IC,80C652 40 PLCC ST 8-BIT MICROC
IC903	0IPH743730E	IC,74HCT373D 20SOP R/TP ADDRESS L
IC904	0IZZVC0041C	IC,M27C512_10F1 DIP BK 512K ML012
"	0IZZVC0041D	IC,M27C512_10F1 DIP BK 512K ML012
IC905	0ISS416162C	IC,K4S161622E-TC80 50TSOP R/TP SD
IC906	0ISS416162C	IC,K4S161622E-TC80 50TSOP R/TP SD
IC907	0IPH740400G	IC,74HC04D HEX INVERTER 14P,SOP T
IC908	0IAL241610A	IC,AT24C16N-10SI 8P SOIC ST EEPRO
IC909	0IMCRFA020A	IC,RC1587DT_36 FAIRCHILD 3P TO252
IC914	0IMCRTH001A	IC,THC63LVDM83R THINE ELECTRONICS
Q1	0IFA270000A	IC,2N7000TA TO-92, 3P TP LEVEL SH
Q2	0IFA270000A	IC,2N7000TA TO-92, 3P TP LEVEL SH
DIODE		
D1	0DD181009AB	DIODE,SWITCHING KDS181 TP KEC 85V 300M
D2	0DD181009AB	DIODE,SWITCHING KDS181 TP KEC 85V 300M
D601	0DD181009AB	DIODE,SWITCHING KDS181 TP KEC 85V 300M
D602	0DD181009AB	DIODE,SWITCHING KDS181 TP KEC 85V 300M
D801	0DD181009AB	DIODE,SWITCHING KDS181 TP KEC 85V 300M
D802	0DD181009AB	DIODE,SWITCHING KDS181 TP KEC 85V 300M
D805	0DD181009AB	DIODE,SWITCHING KDS181 TP KEC 85V 300M
LD1101	0DL112100AB	LED SM3411(DL-11S2GN1) BK Y-GREEN
ZD101	0DZ330009BA	DIODE,ZENER HZT33(TP) HITACHI
TRANSISTOR		
IC802	0TFVI80001A	TR,VISHAY SI4808DY R/TP SO-8 30V
IC803	0TFVI80001A	TR,VISHAY SI4808DY R/TP SO-8 30V
IC804	0TFVI80005A	TR,VISHAY SI4963DY R/TP SO-8 -20V
IC805	0TF492509AA	FET,SI4925DY TP TEMIC 30V 6.1A SO
IC913	0TF492509AA	FET,SI4925DY TP TEMIC 30V 6.1A SO
Q3	0TR387500AA	TR,CHIP 2SC3875S(ALY) KEC
Q4	0TR387500AA	TR,CHIP 2SC3875S(ALY) KEC

LOCA. NO	PART NO	DESCRIPTION
Q5	0TR387500AA	TR,CHIP 2SC3875S(ALY) KEC
Q107	0TR387500AA	TR,CHIP 2SC3875S(ALY) KEC
Q204	0TR387500AA	TR,CHIP 2SC3875S(ALY) KEC
Q205	0TR387500AA	TR,CHIP 2SC3875S(ALY) KEC
Q206	0TR387500AA	TR,CHIP 2SC3875S(ALY) KEC
Q207	0TR387500AA	TR,CHIP 2SC3875S(ALY) KEC
Q208	0TR387500AA	TR,CHIP 2SC3875S(ALY) KEC
Q209	0TR387500AA	TR,CHIP 2SC3875S(ALY) KEC
Q210	0TR387500AA	TR,CHIP 2SC3875S(ALY) KEC
Q301	0TR387500AA	TR,CHIP 2SC3875S(ALY) KEC
Q605	0TR150400BA	TR,CHIP 2SA1504S(ASY) KEC
Q801	0TR387500AA	TR,CHIP 2SC3875S(ALY) KEC
Q901	0TR387500AA	TR,CHIP 2SC3875S(ALY) KEC
Q903	0TR387500AA	TR,CHIP 2SC3875S(ALY) KEC
Q904	0TR387500AA	TR,CHIP 2SC3875S(ALY) KEC
Q1101	0TR150400BA	TR,CHIP 2SA1504S(ASY) KEC
CAPACITOR		
C17	0CE107SF6DC	100UF MVG 16V M SMD R/TP
C20	0CE107SF6DC	100UF MVG 16V M SMD R/TP
C21	0CE106SF6DC	10UF MVG 16V 20% R/TP(SMD) SMD
C24	0CE107SF6DC	100UF MVG 16V M SMD R/TP
C25	0CE227VF6DC	220UF MV 16V 20% R/TP(SMD) SMD
C60	0CK224DF56A	220000PF 2012 16V 10% R/TP X7R
C63	0CE476SF6DC	47UF MVG 16V M SMD R/TP
C101	0CE476DH618	47UF STD 25V 20% FL TP 5
C105	0CE106DK618	10UF STD 50V M FL TP5
C107	0CE108DD618	1000UF STD 10V M FL TP5
C113	0CE105DK618	1UF STD 50V M FL TP5
C114	0CE476DF618	47UF STD 16V M FL TP5
C115	0CE107DF618	100UF STD 16V M FL TP5
C209	0CE225VK6DC	2.2UF MV 50V 20% R/TP(SMD) SMD
C214	0CE476SF6DC	47UF MVG 16V M SMD R/TP
C217	0CE106SF6DC	10UF MVG 16V 20% R/TP(SMD) SMD
C220	0CE106SF6DC	10UF MVG 16V 20% R/TP(SMD) SMD
C221	0CE106SF6DC	10UF MVG 16V 20% R/TP(SMD) SMD
C302	0CE476SF6DC	47UF MVG 16V M SMD R/TP
C323	0CE106SF6DC	10UF MVG 16V 20% R/TP(SMD) SMD
C331	0CK224DF56A	220000PF 2012 16V 10% R/TP X7R
C332	0CK224DF56A	220000PF 2012 16V 10% R/TP X7R
C333	0CK224DF56A	220000PF 2012 16V 10% R/TP X7R
C334	0CK224DF56A	220000PF 2012 16V 10% R/TP X7R
C335	0CK224DF56A	220000PF 2012 16V 10% R/TP X7R
C336	0CK224DF56A	220000PF 2012 16V 10% R/TP X7R
C347	0CK224DF56A	220000PF 2012 16V 10% R/TP X7R
C354	0CK224DF56A	220000PF 2012 16V 10% R/TP X7R
C361	0CE105CK636	1UF SHL,SD 50V M FM5 BP(D) TP
C362	0CE105CK636	1UF SHL,SD 50V M FM5 BP(D) TP
C363	0CE105CK636	1UF SHL,SD 50V M FM5 BP(D) TP

For Capacitor & Resistors, the characters at 2nd and 3rd digit in the P/No. means as follows;	CC, CX, CK, CN : Ceramic CQ : Polyester CE : Electrolytic	RD : Carbon Film RS : Metal Oxide Film RN : Metal Film RF : Fusible
---	---	--

LOCA. NO	PART NO	DESCRIPTION
C364	0CE105CK636	1UF SHL,SD 50V M FM5 BP(D) TP
C365	0CK224DF56A	220000PF 2012 16V 10% R/TP X7R
C406	0CE476SF6DC	47UF MVG 16V M SMD R/TP
C418	0CE107SF6DC	100UF MVG 16V M SMD R/TP
C493	0CE106SF6DC	10UF MVG 16V 20% R/TP(SMD) SMD
C494	0CE107SF6DC	100UF MVG 16V M SMD R/TP
C495	0CE107SF6DC	100UF MVG 16V M SMD R/TP
C610	0CE107DF618	100UF STD 16V M FL TP5
C614	0CE107DF618	100UF STD 16V M FL TP5
C618	0CK224DF56A	220000PF 2012 16V 10% R/TP X7R
C619	0CK224DF56A	220000PF 2012 16V 10% R/TP X7R
C620	0CK224DF56A	220000PF 2012 16V 10% R/TP X7R
C621	0CK224DF56A	220000PF 2012 16V 10% R/TP X7R
C622	0CE476DF618	47UF STD 16V M FL TP5
C631	0CE106DF618	10UF STD 16V M FL TP5
C632	0CE106DF618	10UF STD 16V M FL TP5
C633	0CE335DK618	3.3UF STD 50V 20% FL TP 5
C635	0CE107DF618	100UF STD 16V M FL TP5
C638	0CE107DF618	100UF STD 16V M FL TP5
C639	0CE107DF618	100UF STD 16V M FL TP5
C640	0CE477DF618	470UF STD 16V 20% FL TP 5
C643	0CE477DF618	470UF STD 16V 20% FL TP 5
C644	0CE107DF618	100UF STD 16V M FL TP5
C645	0CE107DH618	100UF STD 25V M FL TP5
C647	0CE225DK618	2.2UF STD 50V 20% FL TP 5
C648	0CE225DK618	2.2UF STD 50V 20% FL TP 5
C649	0CQ1031N509	0.01U 100V K POLY TP
C650	0CE477DF618	470UF STD 16V 20% FL TP 5
C651	0CE476DF618	47UF STD 16V M FL TP5
C652	0CQ1031N509	0.01U 100V K POLY TP
C653	0CE107DF618	100UF STD 16V M FL TP5
C654	0CK224DF56A	220000PF 2012 16V 10% R/TP X7R
C655	0CK224DF56A	220000PF 2012 16V 10% R/TP X7R
C801	0CE476DK618	47UF STD 50V M FL TP5
C802	0CE477DF618	470UF STD 16V 20% FL TP 5
C803	0CE477DF618	470UF STD 16V 20% FL TP 5
C804	0CE477DF618	470UF STD 16V 20% FL TP 5
C805	0CE687DD618	680UF STD 10V 20% FL TP 5
C806	0CE687DD618	680UF STD 10V 20% FL TP 5
C807	0CE687DD618	680UF STD 10V 20% FL TP 5
C808	0CE227DH618	220UF STD 25V M FL TP5
C814	0CE107DH618	100UF STD 25V M FL TP5
C815	0CE107DH618	100UF STD 25V M FL TP5
C817	0CE475DK618	4.7UF STD 50V 20% FL TP 5
C902	0CE106SF6DC	10UF MVG 16V 20% R/TP(SMD) SMD
C904	0CE106SF6DC	10UF MVG 16V 20% R/TP(SMD) SMD
C906	0CE107SF6DC	100UF MVG 16V M SMD R/TP
C909	0CE107SF6DC	100UF MVG 16V M SMD R/TP
C911	0CE107SF6DC	100UF MVG 16V M SMD R/TP
C915	0CE106SF6DC	10UF MVG 16V 20% R/TP(SMD) SMD
C935	0CE107SF6DC	100UF MVG 16V M SMD R/TP
C939	0CE476SF6DC	47UF MVG 16V M SMD R/TP

LOCA. NO	PART NO	DESCRIPTION
C946	0CE476SF6DC	47UF MVG 16V M SMD R/TP
C970	0CE107SF6DC	100UF MVG 16V M SMD R/TP
C1101	0CE107DD618	100UF STD 10V M FL TP5
JACK		
JA201	6612VAH001A	JACK,PHONE HEC3900-010110 HOSIDEN DC
JA203	6613V00008F	JACK ASSY PMJ014F E/P(ST)+S-VH
JA204	6612VJH008D	JACK,RCA PJ6063D DVD IN 3P GN-
JA205A	380-336E	JACK,RCA WA6013E RCA 1P WH GOL
JA205B	380-336F	JACK,RCA WA6013E RCA RED 1P GO
JA206	6612VCH003B	JACK,PHONE PEJ012C H=6.5 STEREO
COIL & TRANSFORMER		
L102	0LA0272K139	INDUCTOR,27UH K 4X10.5 TP
L802	6140VB0004B	COIL,26UH 1UEWPHY 22.5TURN YL-9N 0.
L803	6140VB0004A	COIL,9.5UH 1UEWPHY 13.5TURN YL-9N 0
L1101	0LA0222K119	INDUCTOR,22UH K 2.3*3.4 TP
T801	6170VTC A30A	TRANSFORMER,SMPS EPC 13-Z 320UH DC-DC CONV. SI-
CONNECTOR		
JA202	6630VGA001B	CONNECTOR,68114-1522 MOLEX-KOR 15PIN
P1	6630VF01810	CONNECTOR,12507WR YEONHO 10P 1.25MM
P2	6602V20005L	CONNECTOR,2.0MM 12P GIL-S LG CABLE
P3	366-932E	CONNECTOR,2.5MM 6P GIL-G LG CABLE S
P202	6602V25004C	CONNECTOR,GT250 LGC 4 2.5 .
P601	366-932C	CONNECTOR,2.5MM 4P GIL-G LG CABLE S
P602	366-932B	CONNECTOR,2.5MM 3P GIL-G LG CABLE S
P1101	6631V20014E	CONNECTOR ASSY,12P 300MM H-B UL 1007
P1103	6631V25049H	CONNECTOR ASSY,4P 200MM H-B UL1007
RESISTOR		
R219	0RD1200H609	120 OHM 1/2 W 5.00% TA52
R220	0RD1200H609	120 OHM 1/2 W 5.00% TA52
R413	0RH0000D622	0 OHM 1 / 10 W 2012 5.00% D
R953	0RH0000D622	0 OHM 1 / 10 W 2012 5.00% D
RA901	0RRZVTA001A	MNR-14-E0A-J-101 R OHM 100 OH
RA902	0RRZVTA001A	MNR-14-E0A-J-101 R OHM 100 OH
RA903	0RRZVTA001A	MNR-14-E0A-J-101 R OHM 100 OH
RA904	0RRZVTA001A	MNR-14-E0A-J-101 R OHM 100 OH
RA905	0RRZVTA001A	MNR-14-E0A-J-101 R OHM 100 OH
RA906	0RRZVTA001A	MNR-14-E0A-J-101 R OHM 100 OH
RA907	0RRZVTA001A	MNR-14-E0A-J-101 R OHM 100 OH
RA908	0RRZVTA001A	MNR-14-E0A-J-101 R OHM 100 OH
RA909	0RRZVTA001A	MNR-14-E0A-J-101 R OHM 100 OH
RA910	0RRZVTA001A	MNR-14-E0A-J-101 R OHM 100 OH
RA911	0RRZVTA001A	MNR-14-E0A-J-101 R OHM 100 OH
RA912	0RRZVTA001A	MNR-14-E0A-J-101 R OHM 100 OH
RA926	0RRZVTA001A	MNR-14-E0A-J-101 R OHM 100 OH
RA927	0RRZVTA001A	MNR-14-E0A-J-101 R OHM 100 OH
RA928	0RRZVTA001A	MNR-14-E0A-J-101 R OHM 100 OH
RA929	0RRZVTA001A	MNR-14-E0A-J-101 R OHM 100 OH
RA930	0RRZVTA001A	MNR-14-E0A-J-101 R OHM 100 OH

For Capacitor & Resistors, the characters at 2nd and 3rd digit in the P/No. means as follows;

CC, CX, CK, CN : Ceramic	RD : Carbon Film
CQ : Polyester	RS : Metal Oxide Film
CE : Electrolytic	RN : Metal Film
	RF : Fusible

LOCA. NO	PART NO	DESCRIPTION
RA931	ORRZVTA001A	MNR-14-E0A-J-101 R OHM 100 OH
SWITCH		
SW1101	140-313A	SWITCH,TACT 2LEAD 100G(TA) LG C&D NON
SW1101	6600VM1001A	SWITCH,PUSH SDKLA1 UL/CSA 250V 5A VER
SW1102	140-313A	SWITCH,TACT 2LEAD 100G(TA) LG C&D NON
SW1103	140-313A	SWITCH,TACT 2LEAD 100G(TA) LG C&D NON
SW1104	140-313A	SWITCH,TACT 2LEAD 100G(TA) LG C&D NON
SW1105	140-313A	SWITCH,TACT 2LEAD 100G(TA) LG C&D NON
SW1106	140-313A	SWITCH,TACT 2LEAD 100G(TA) LG C&D NON
SW1107	140-313A	SWITCH,TACT 2LEAD 100G(TA) LG C&D NON
CRYSTAL & FILTER		
L2	6210TCE001G	FILTER,HH-1M3216-501 CERATEC 3216MM R
L3	6210TCE001G	FILTER,HH-1M3216-501 CERATEC 3216MM R
L4	6210TCE001G	FILTER,HH-1M3216-501 CERATEC 3216MM R
L101	6210TCE001G	FILTER,HH-1M3216-501 CERATEC 3216MM R
L103	6210TCE001G	FILTER,HH-1M3216-501 CERATEC 3216MM R
L104	6210TCE001G	FILTER,HH-1M3216-501 CERATEC 3216MM R
L106	6210TCE001G	FILTER,HH-1M3216-501 CERATEC 3216MM R
L107	6210TCE001G	FILTER,HH-1M3216-501 CERATEC 3216MM R
L201	6210TCE001A	FILTER,HB-1S2012-080JT CERATEC 2012MM
L202	6210TCE001A	FILTER,HB-1S2012-080JT CERATEC 2012MM
L204	6210TCE001A	FILTER,HB-1S2012-080JT CERATEC 2012MM
L205	6210TCE001A	FILTER,HB-1S2012-080JT CERATEC 2012MM
L206	6210TCE001A	FILTER,HB-1S2012-080JT CERATEC 2012MM
L207	6210TCE001G	FILTER,HH-1M3216-501 CERATEC 3216MM R
L215	6210TCE001A	FILTER,HB-1S2012-080JT CERATEC 2012MM
L216	6210TCE001A	FILTER,HB-1S2012-080JT CERATEC 2012MM
L276	6210TCE001A	FILTER,HB-1S2012-080JT CERATEC 2012MM
L277	6210TCE001A	FILTER,HB-1S2012-080JT CERATEC 2012MM
L301	6210TCE001G	FILTER,HH-1M3216-501 CERATEC 3216MM R
L302	6210TCE001G	FILTER,HH-1M3216-501 CERATEC 3216MM R
L303	6210TCE001A	FILTER,HB-1S2012-080JT CERATEC 2012MM
L304	6210TCE001G	FILTER,HH-1M3216-501 CERATEC 3216MM R
L601	6210TCE001G	FILTER,HH-1M3216-501 CERATEC 3216MM R
L602	6210TCE001G	FILTER,HH-1M3216-501 CERATEC 3216MM R
L603	6210TCE001G	FILTER,HH-1M3216-501 CERATEC 3216MM R
L604	6210TCE001G	FILTER,HH-1M3216-501 CERATEC 3216MM R
L801	6210TCE001G	FILTER,HH-1M3216-501 CERATEC 3216MM R
L804	6210TCE001G	FILTER,HH-1M3216-501 CERATEC 3216MM R
L805	6210TCE001G	FILTER,HH-1M3216-501 CERATEC 3216MM R
L901	6210TCE001G	FILTER,HH-1M3216-501 CERATEC 3216MM R
L902	6210TCE001G	FILTER,HH-1M3216-501 CERATEC 3216MM R
L904	6210TCE001G	FILTER,HH-1M3216-501 CERATEC 3216MM R
L905	6210TCE001G	FILTER,HH-1M3216-501 CERATEC 3216MM R
L908	6210TCE001G	FILTER,HH-1M3216-501 CERATEC 3216MM R
L911	6210TCE001G	FILTER,HH-1M3216-501 CERATEC 3216MM R
L913	6210TCE001G	FILTER,HH-1M3216-501 CERATEC 3216MM R
L917	6210TCE001G	FILTER,HH-1M3216-501 CERATEC 3216MM R
L918	6210TCE001G	FILTER,HH-1M3216-501 CERATEC 3216MM R
X1	156-A01L	RESONATOR,CRYSTAL HC49U 6.000MHZ

LOCA. NO	PART NO	DESCRIPTION
X301	6202VDT002E	RESONATOR,CRYSTAL SX-1SMD 20250000H
X601	156-A02M	RESONATOR,CRYSTAL HC49U 18.432MHZ 30P
X901	6202VDT002B	RESONATOR,CRYSTAL SX-1SMD 14.318MHZ
ACCESSORIES		
A1	3828VA0334H	MANUAL,OWNERS ML012A RUS/BZ03 LG RU/EN
A2	6710V00061U	REMOTE CONTROLLER ML-012A WITH PIP 34KEY
A4	6634B00043B	ADAPTER,AC-DC SAD6012SE 12V 5.0A 60W
MISCELLANEOUS		
PA1101	6700MF0003A	TUNER TAFH-Z342D LG MULTI FS
P801	6726VV0006D	REMOTE CONTROLLER RECEIVER 38.0KHZ
	6410VEH003A	POWER CORD M2511A-001 VOLEX VDE/SEMKO

Teletext Group Delay Circuit

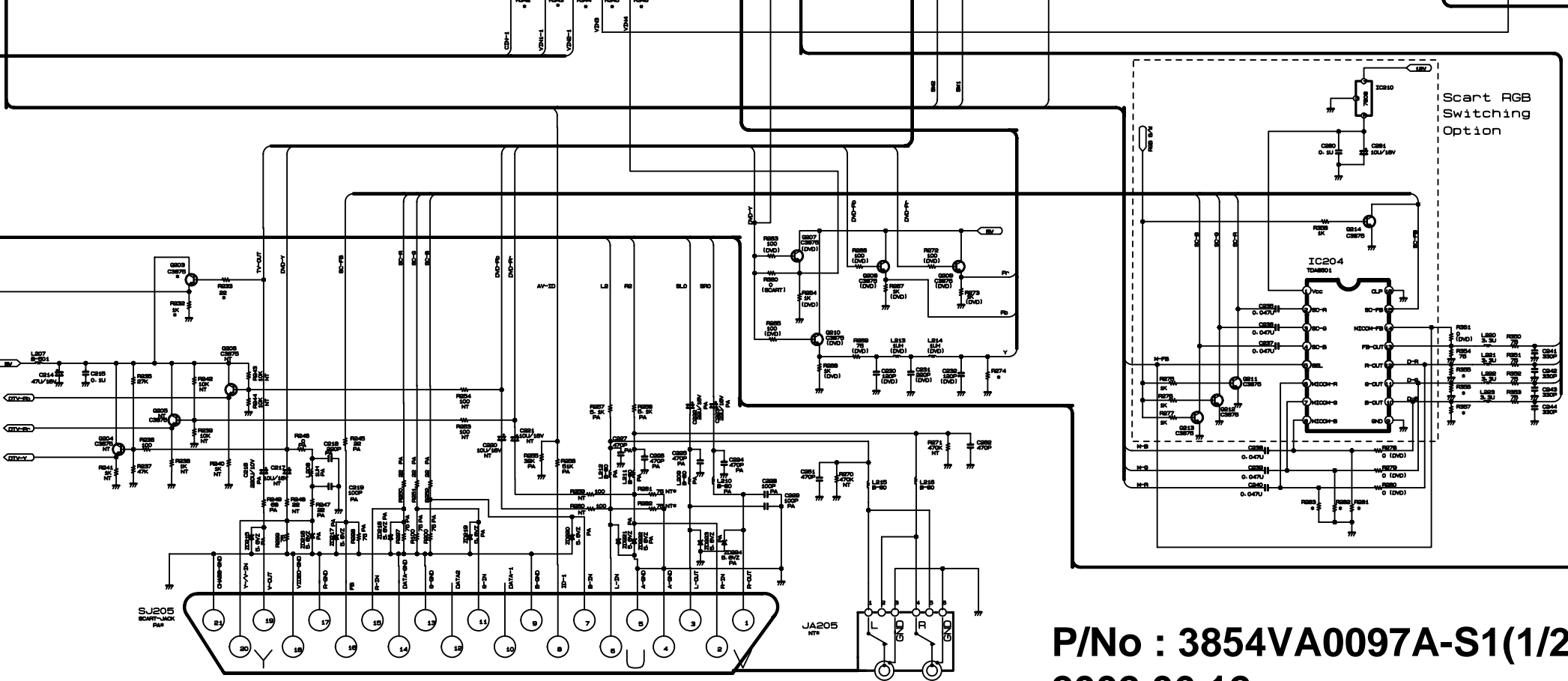
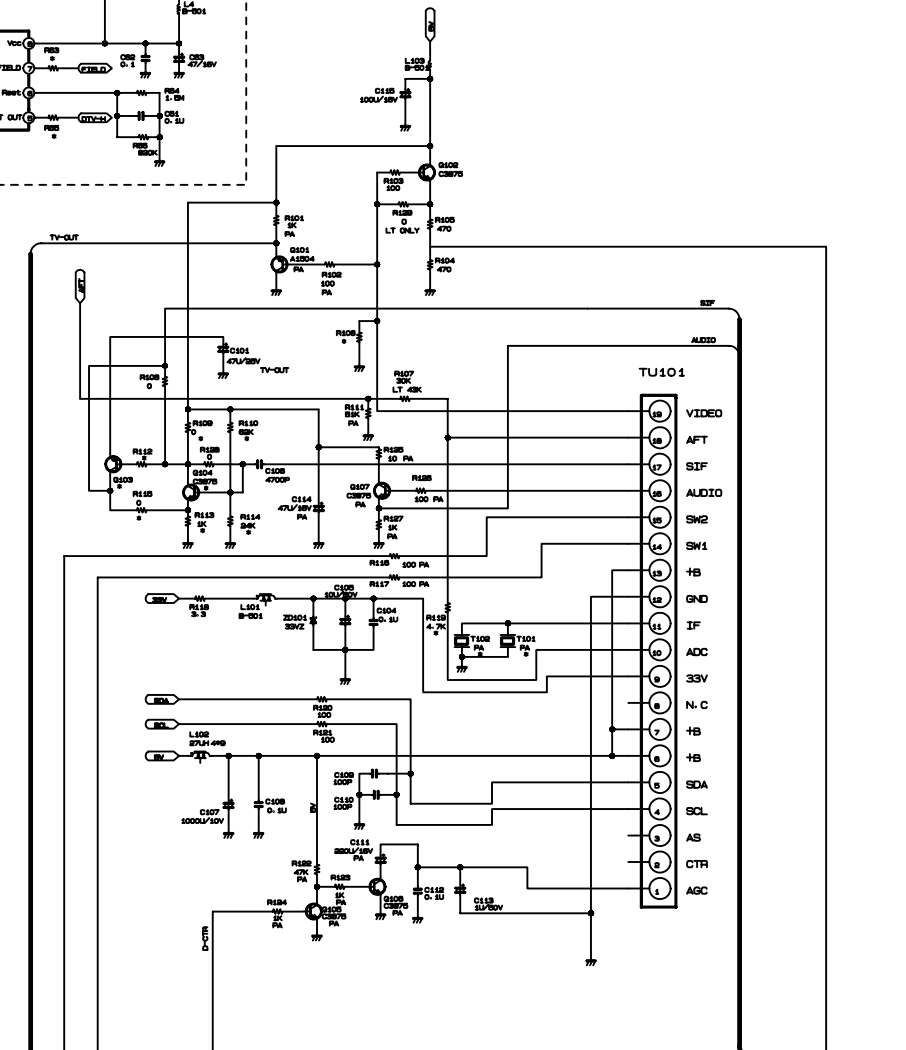
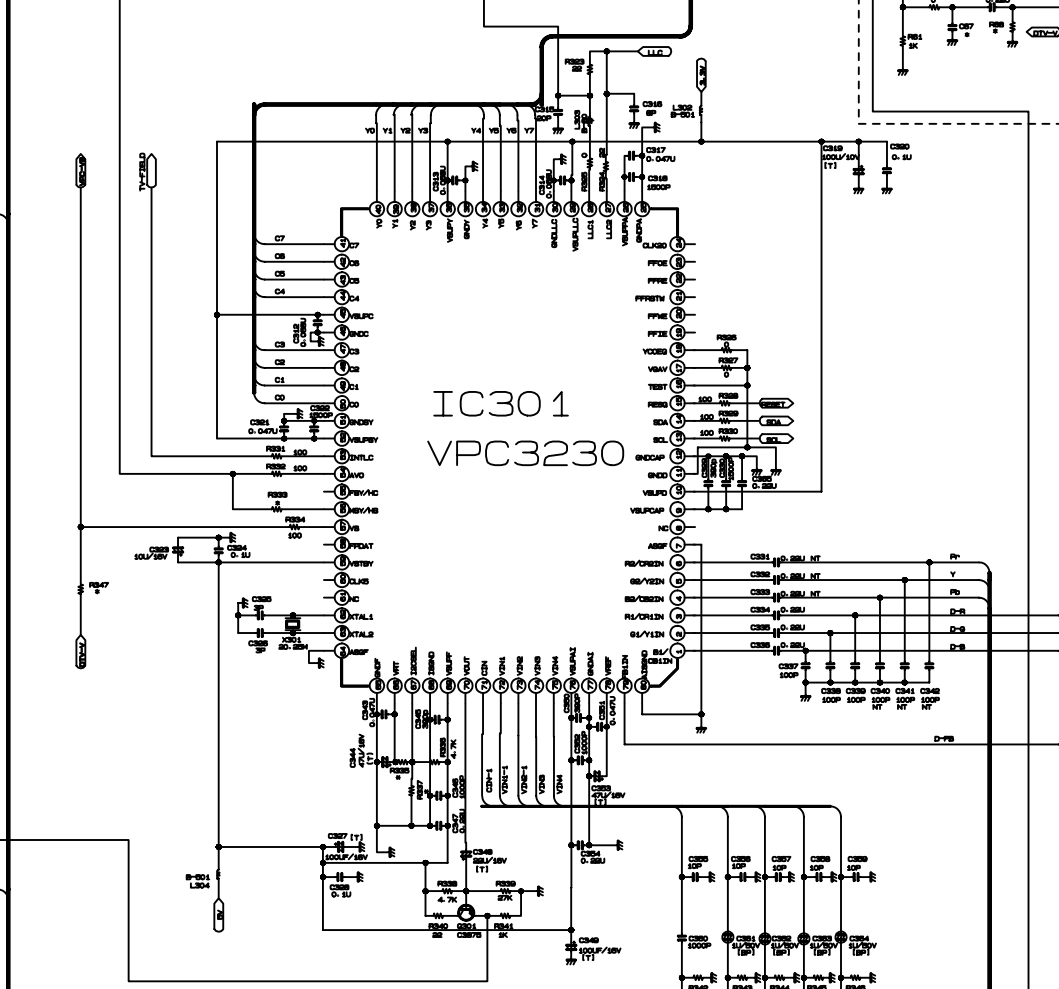
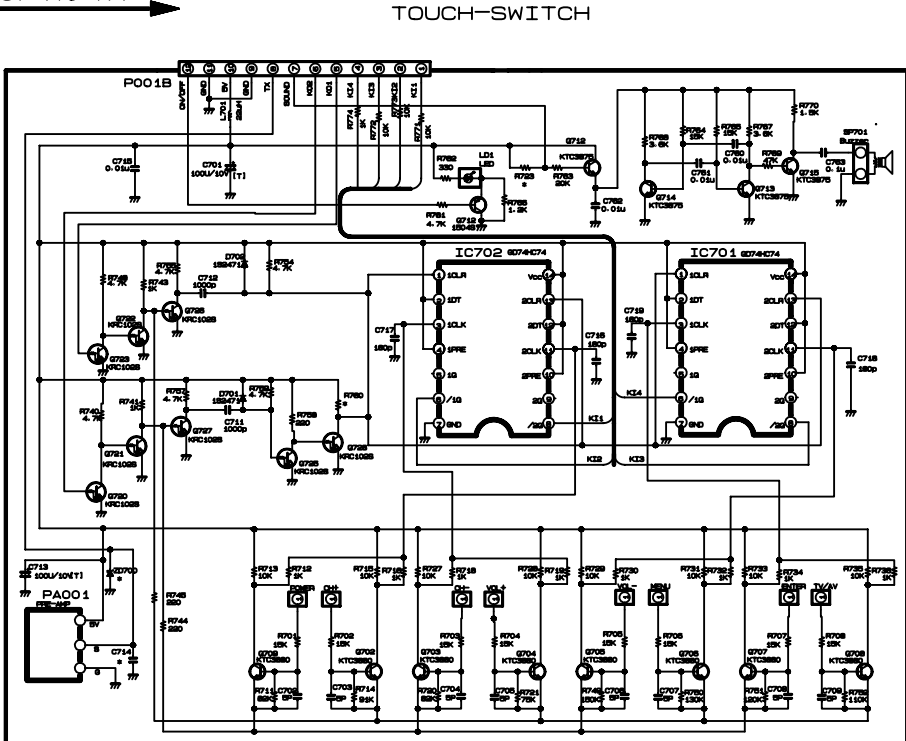
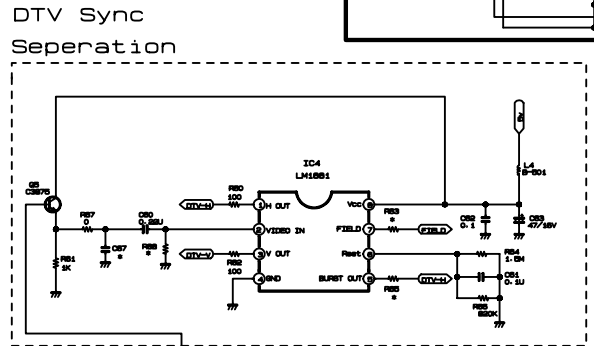
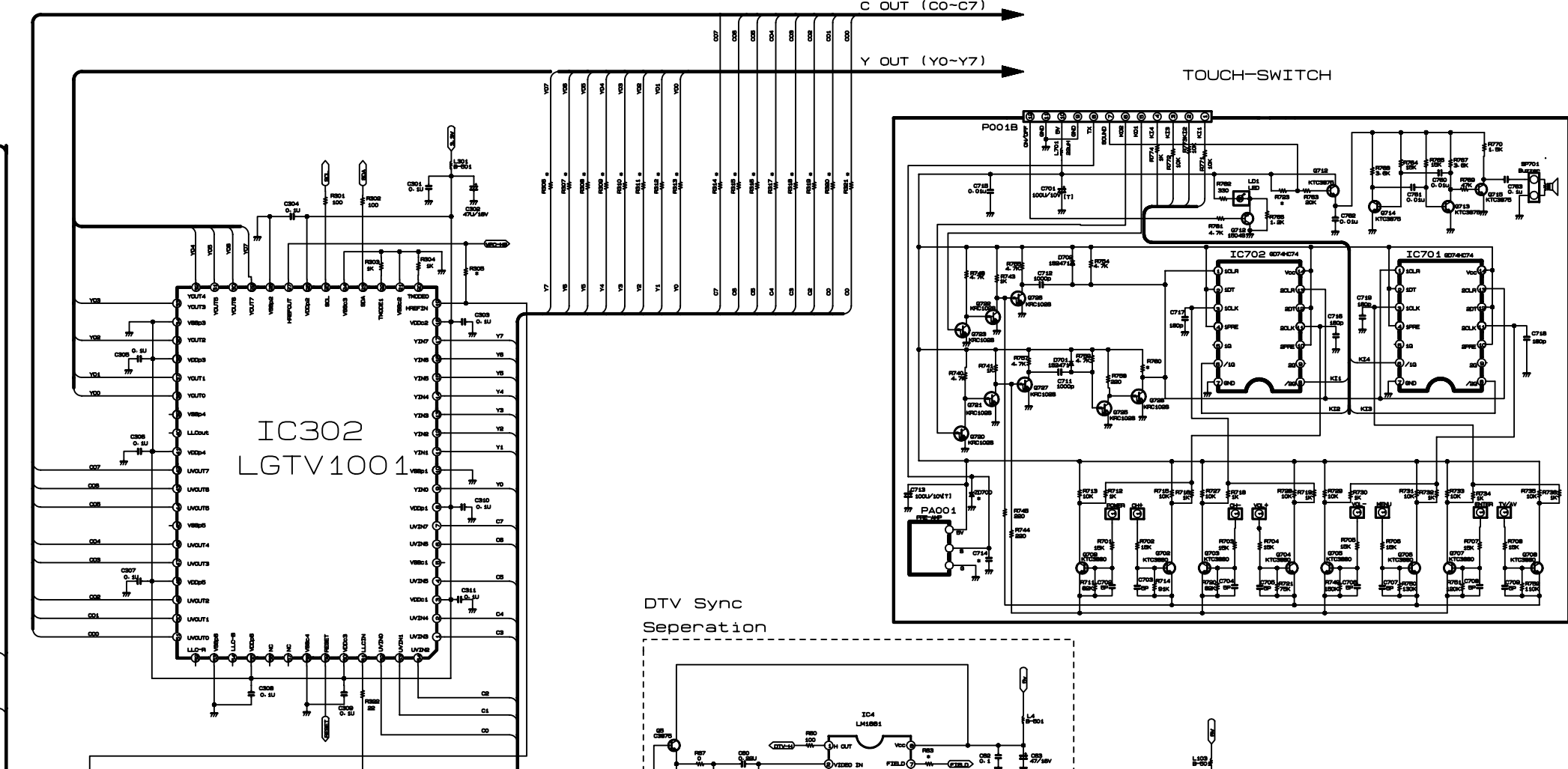
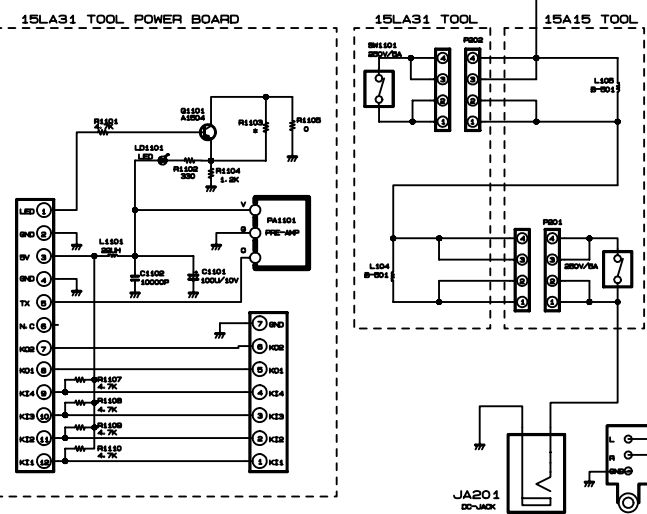
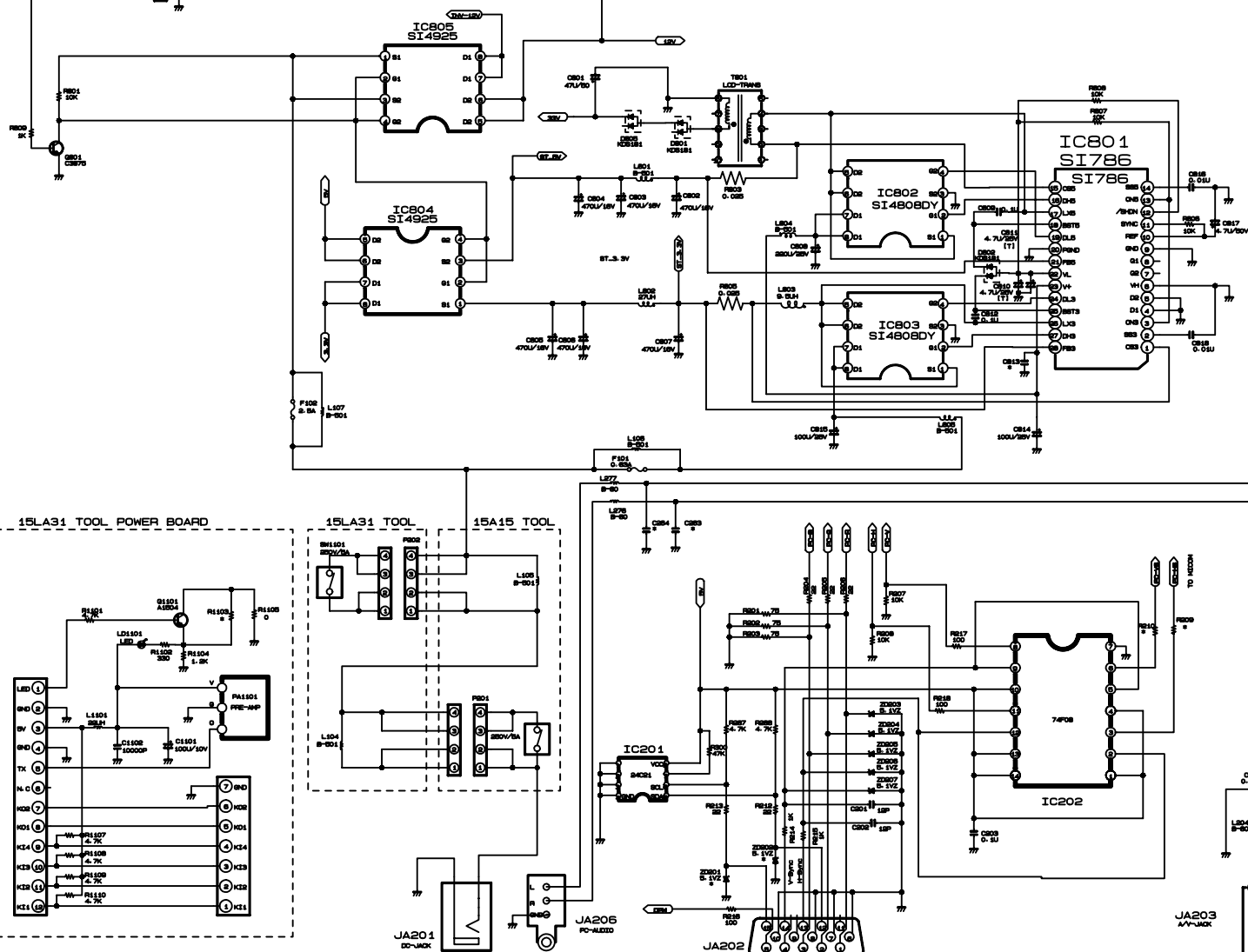
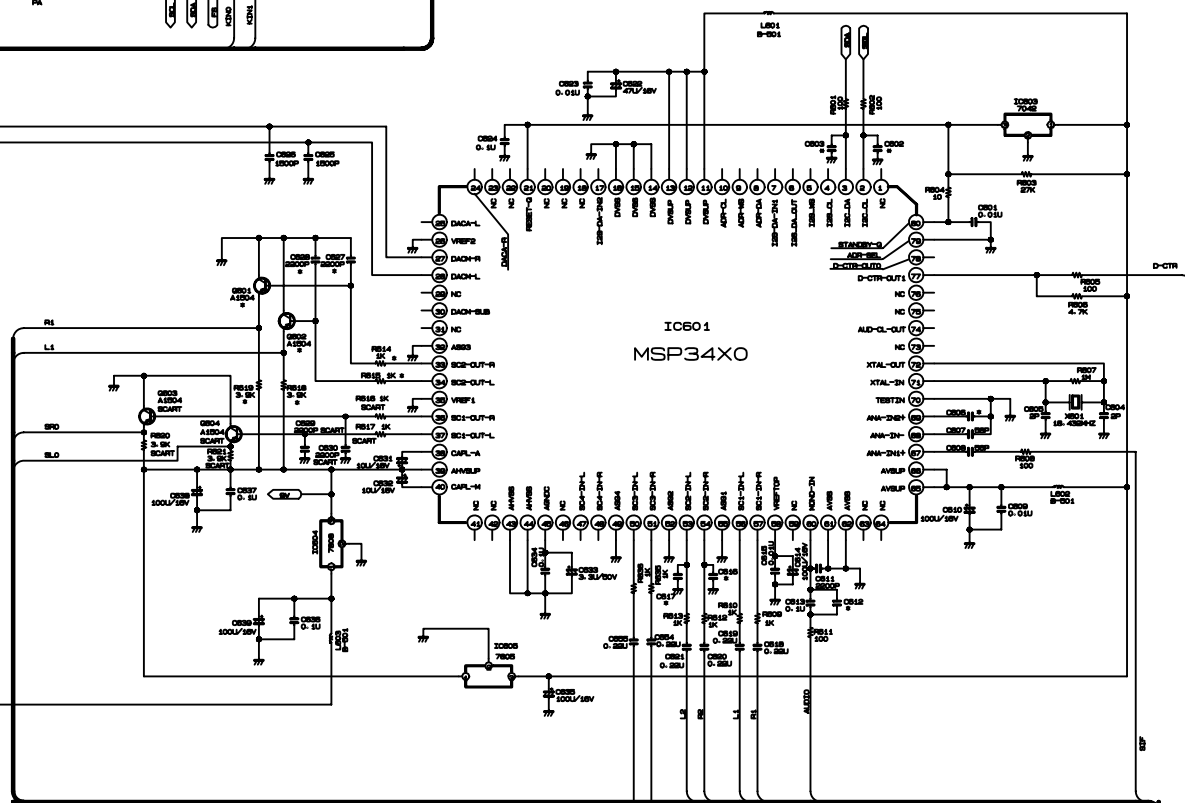
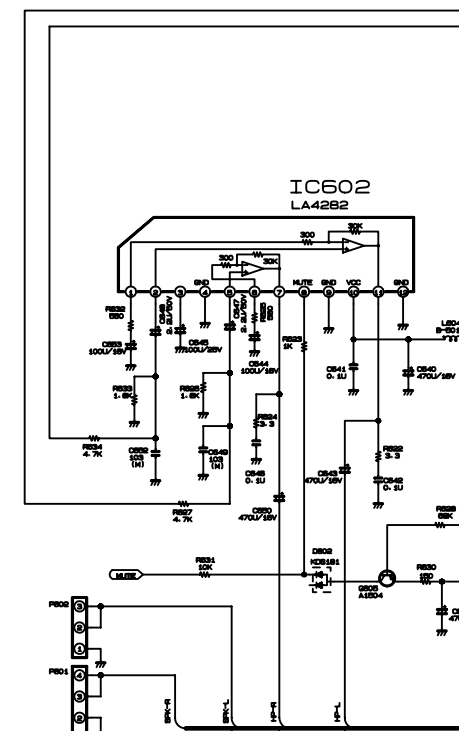
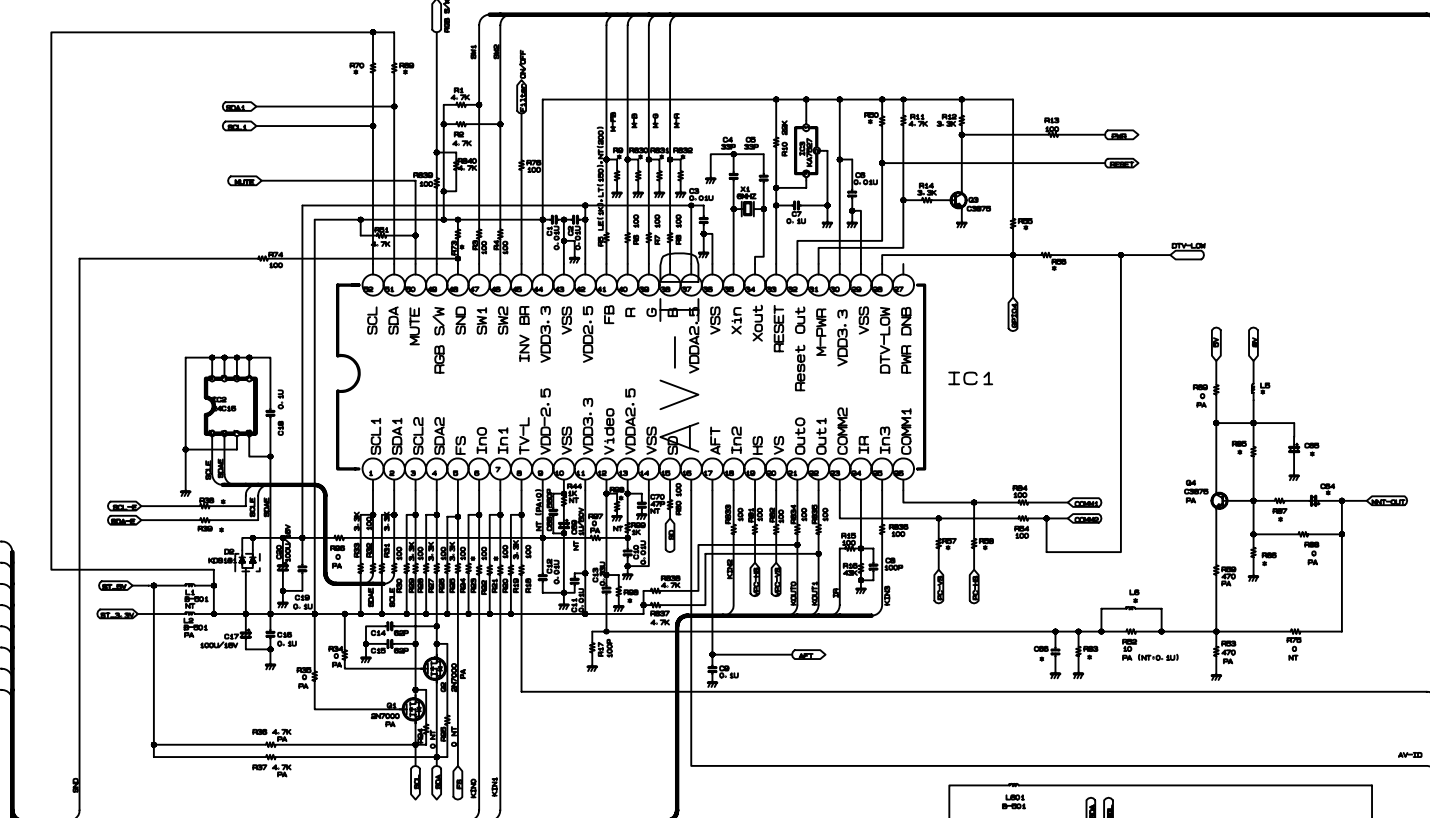
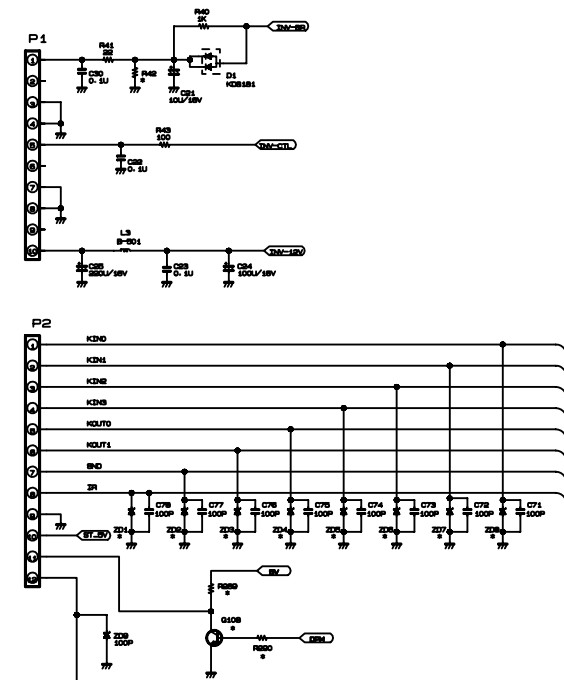
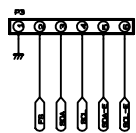
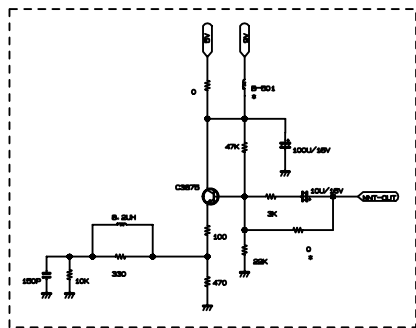

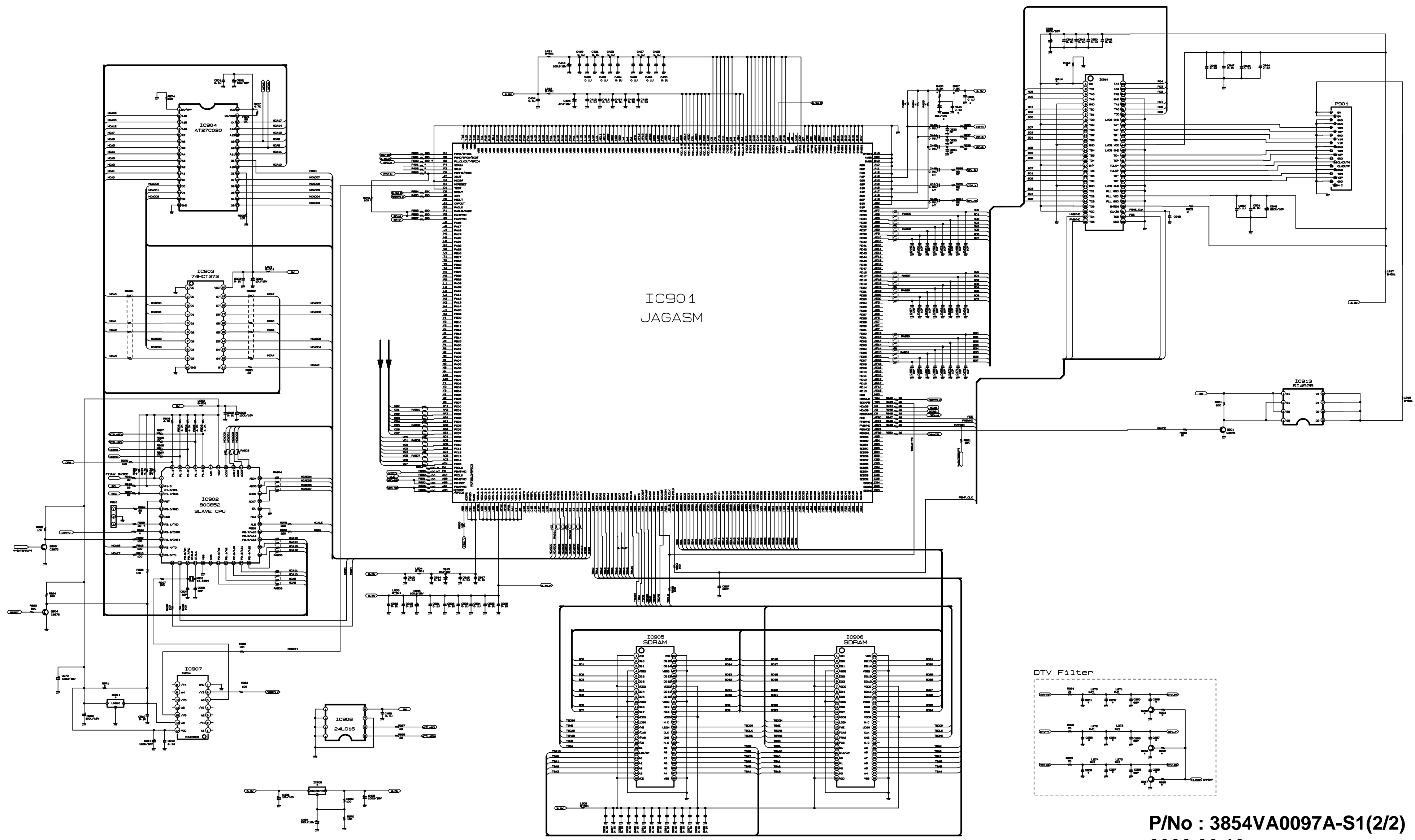

IC901
JAGASM

PRINTED CIRCUIT BOARD

MAIN(TOP)

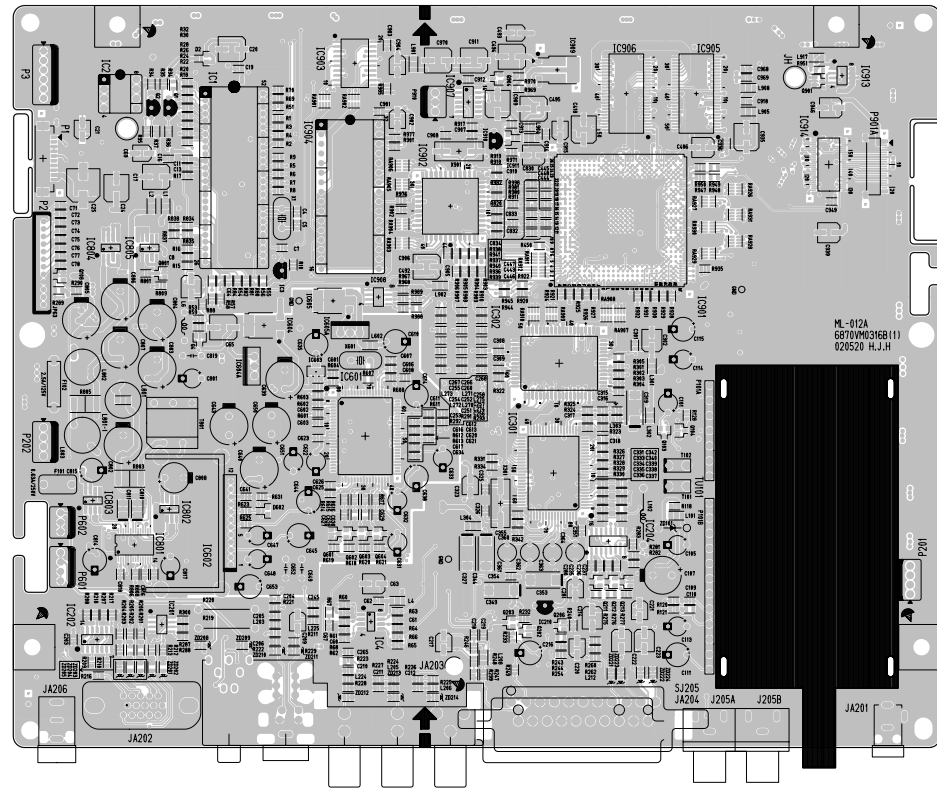

MAIN(BOTTOM)

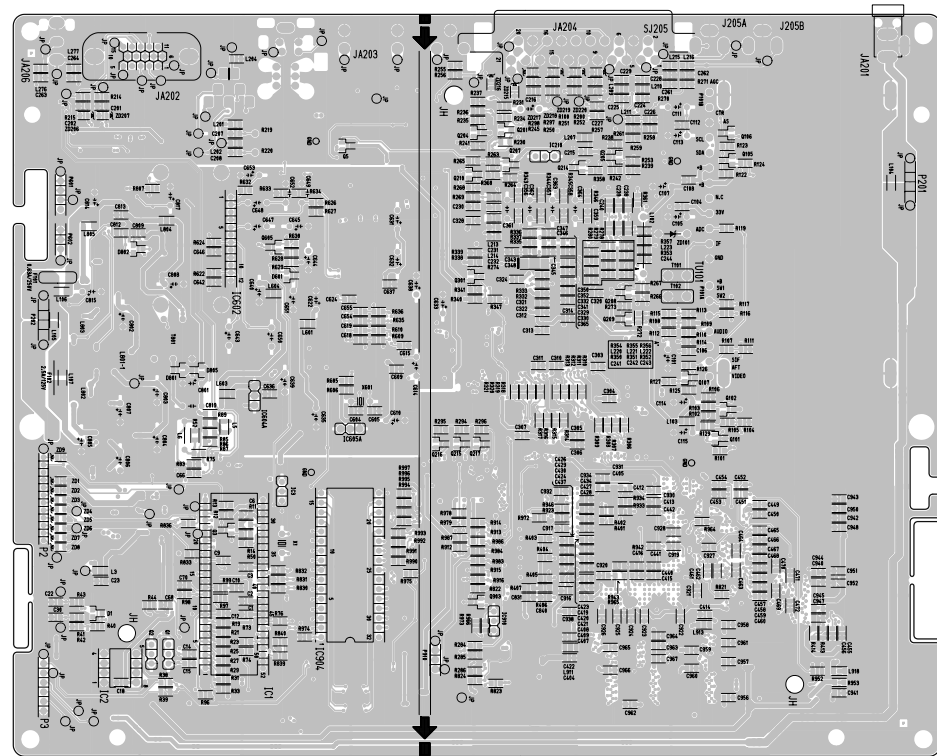

CONTROL(TOP)

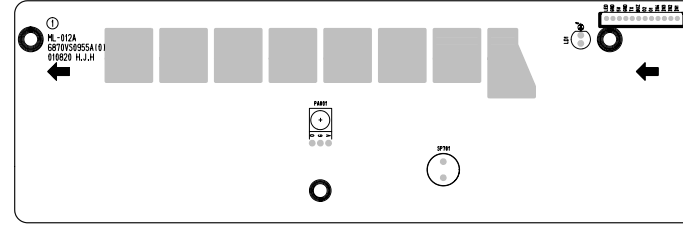

CONTROL(BOTTOM)

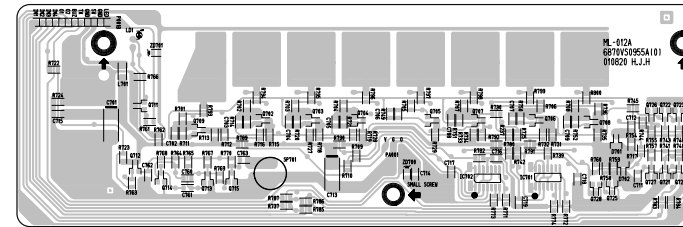

SVC. SHEET : 3854VA0097A-S