

The documentation and process conversion measures necessary to comply with this revision shall be completed by 15 November 1999.

INCH-POUND

MIL-PRF-19500/304D
15 August 1999
SUPERSEDING
MIL-S-19500/304C
6 June 1989

PERFORMANCE SPECIFICATION SHEET

SEMICONDUCTOR DEVICE, DIODE, SILICON, POWER RECTIFIER, FAST RECOVERY
TYPES 1N3885, 1N3886, 1N3888, 1N3890, 1N3891, 1N3893,
1N3890R, 1N3891R, 1N3893R AND A-VERSIONS
JAN, JANTX, JANTXV, JANS, JANHC AND JANKC

This specification is approved for use by all Departments and Agencies of the Department of Defense.

1. SCOPE

1.1 Scope. This specification covers the performance requirements for 12 and 20 ampere, silicon fast recovery, power, rectifier diodes. . Four levels of product assurance are provided for each encapsulated device type as specified in MIL-PRF-19500, and two levels of product assurance for each unencapsulated device type..

1.2 Physical dimensions. See figures 1 and 2 (DO-4), and 3 (die).

1.3 Maximum ratings. $T_C = 25^\circ\text{C}$ unless otherwise specified.

Type	V_R	V_{RWM}	$I_O \downarrow$ $T_C = 100^\circ\text{C}$	I_{FSM} $T_C = 100^\circ\text{C}$ $t = 1/120 \text{ s}$	t_{rr}	T_C
	<u>V</u>	<u>V (pk)</u>	<u>A dc</u>	<u>A (pk)</u>	<u>ns</u>	<u>°C</u>
1N3885	100	100	12	150	200	-65 to + 150
1N3885A	100	100	20	225	150	-65 to + 150
1N3890, R	100	100	12	175	200	-65 to + 150
1N3890A, AR	100	100	20	250	150	-65 to + 150
1N3886	200	200	12	150	200	-65 to + 150
1N3886A	200	200	20	225	150	-65 to + 150
1N3891, R	200	200	12	175	200	-65 to + 150
1N3891A, AR	200	200	20	250	150	-65 to + 150
1N3888	400	400	12	150	200	-65 to + 150
1N3888A	400	400	20	225	150	-65 to + 150
1N3893, R	400	400	12	175	200	-65 to + 150
1N3893A, AR	400	400	20	250	150	-65 to + 150

\downarrow Derate linearly 2 percent of I_O /°C for $T_C > 100^\circ\text{C}$.

Storage temperature: $T_C = -65^\circ\text{C}$ to $+150^\circ\text{C}$ – 1N3885, 1N3886, 1N3888 and A – versions.

Storage temperature: $T_C = -65^\circ\text{C}$ to $+175^\circ\text{C}$ – 1N3890, 1N3891, 1N3893 and A, R, AR – versions.

Barometric pressure reduced: 15 mmHg.

Beneficial comments (recommendations, additions, deletions) and any pertinent data which may be of use in improving this document should be addressed to: Commander, Defense Supply Center Columbus, ATTN: DSCC-VAC, 3990 East Broad St., Columbus, OH 43216-5000, by using the addressed Standardization Document Improvement Proposal (DD Form 1426) appearing at the end of this document or by letter.

AMSC N/A

FSC 5961

DISTRIBUTION STATEMENT A. Approved for public release; distribution is unlimited.

1.4 Primary electrical characteristics. $T_C = 25^\circ\text{C}$ unless otherwise specified.

Type	I_{R1}		I_{R2} $T_A = +150^\circ\text{C}$	
	VR (V dc)	$\mu\text{A dc}$	VR (V dc)	mA dc
1N3885, A, 1N3890, A, 1N3890R, AR	100	10.0	100	2
1N3886, A, 1N3891, A, 1N3891R, AR	200	10.0	200	2
1N3888, A, 1N3893, A, 1N3893R, AR	400	10.0	400	2

Type	$R_{\theta JC}$ $^\circ\text{C/W}$
Isolated non – A	3.0
Isolated A	2.5
Non isolated non – A	2.0
Non isolated A	1.5

2. APPLICABLE DOCUMENTS

2.1 General. The documents listed in this section are specified in sections 3 and 4 of this specification. This section does not include documents cited in other sections of this specification or recommended for additional information or as examples. While every effort has been made to ensure the completeness of this list, document users are cautioned that they must meet all specified requirements documents cited in section 3 and 4 of this specification, whether or not they are listed.

2.1.1 Specifications, standards, and handbooks. The following specifications, standards, and handbooks form a part of this document to the extent specified herein. Unless otherwise specified, the issues of these documents are those listed in the issue of the Department of Defense Index of Specifications and Standards (DODISS) and supplement thereto, cited in the solicitation (see 6.2).

SPECIFICATION

DEPARTMENT OF DEFENSE

MIL-PRF-19500 - Semiconductor Devices, General Specification for.

STANDARD

FEDERAL

FED-STD-H28 -- Screw Thread Standards For Federal Services.

MILITARY

MIL-STD-750 - Test Methods for Semiconductor Devices.

(Unless otherwise indicated, copies of federal and military specifications, standards, and handbooks are available from the Standardization Documents Order Desk, 700 Robbins Avenue, Building 4D, Philadelphia, PA 19111-5094.)

2.2 Order of precedence. In the event of a conflict between the text of this specification and the references cited herein (except for associated detail specifications, specification sheets or MS standards), the text of this specification takes precedence. Nothing in this specification, however, supersedes applicable laws and regulations unless a specific exemption has been obtained.

3. REQUIREMENTS

3.2 Abbreviations, symbols, and definitions. Abbreviations, symbols, and definitions used herein shall be as specified in MIL-PRF-19500.

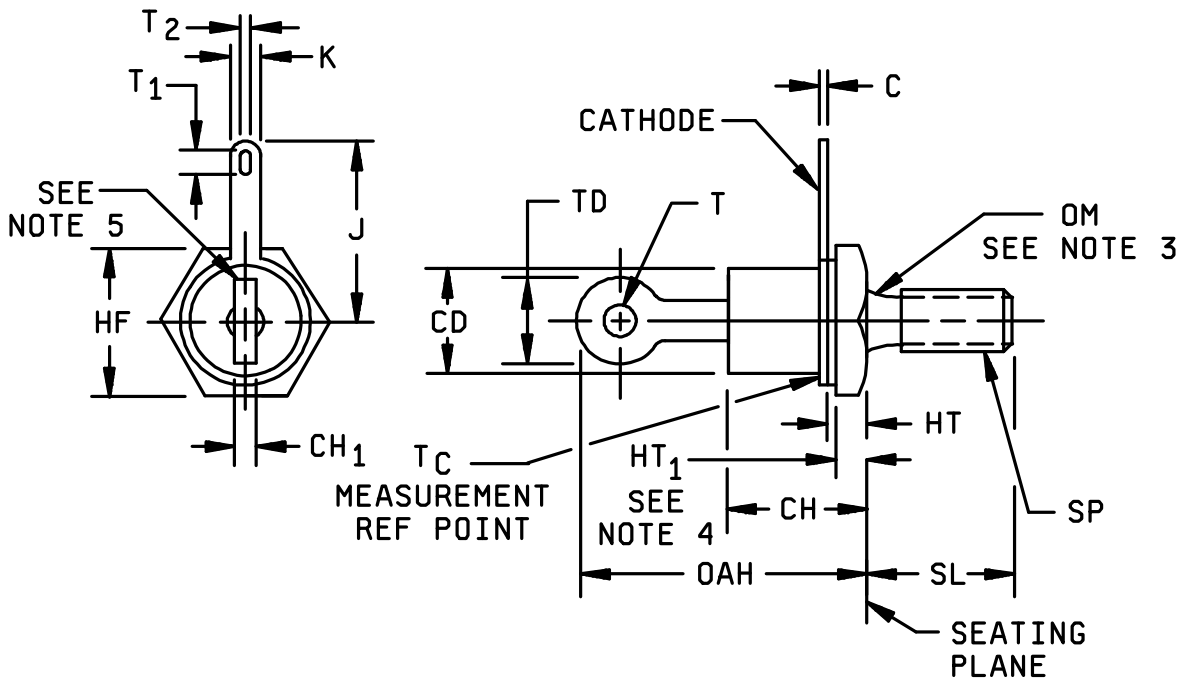

FIGURE 1. Physical dimensions of isolated types: 1N3885, 1N3885A, 1N3886, 1N3886A, 1N3888, and 1N3888A.

MIL-PRF-19500/304D

Ltr	Dimensions				Notes
	Inches		Millimeters		
	Min	Max	Min	Max	
C	0.020	0.038	0.51	0.97	
CD		0.487		12.37	3
CH		0.550		13.97	
CH ₁		0.050		1.27	
HF	0.487	0.500	12.37	12.70	
HT	0.085	0.160	2.16	4.06	
HT ₁	0.040		1.02		
J	0.750	0.875	19.05	22.22	
K	0.110	0.140	2.79	3.56	3
OAH		0.950		24.13	
OM	0.163	0.189	4.14	4.80	
SL	0.422	0.453	10.72	11.50	
SP					5, 6, 7, 8
T	0.060		1.52		
T ₁	0.110	0.140	2.79	3.56	
T ₂	0.055	0.075	1.40	1.90	
TD		0.250		6.35	

NOTES:

1. Dimensions are in inches.
2. Metric equivalents are given for general information only.
3. Angular orientation of this terminal is undefined. Square or radius on end of terminals is optional.
4. Diameter variations within these limits are permitted.
5. The ANSI thread reference is 0.190-32 UNF-2A.
6. Max pitch diameter of plated threads shall be basic pitch diameter 0.169 inch (4.29 mm) reference FED-STD-H28 (Screw Thread Standards for Federal Services.)
7. Units must not be damaged by torque of 15 inch-pounds applied to 0.190-32 UNF-2B nut assembled on thread.
8. Complete threads to extend to within 0.078 inch (1.98 mm) of the seating plane.
9. Stud and seating plane shall be electrically insulated from the case, cathode, and anode.

FIGURE 1. Physical dimensions of isolated types: 1N3885, 1N3885A, 1N3886, 1N3886A, 1N3888, and 1N3888A - Continued.

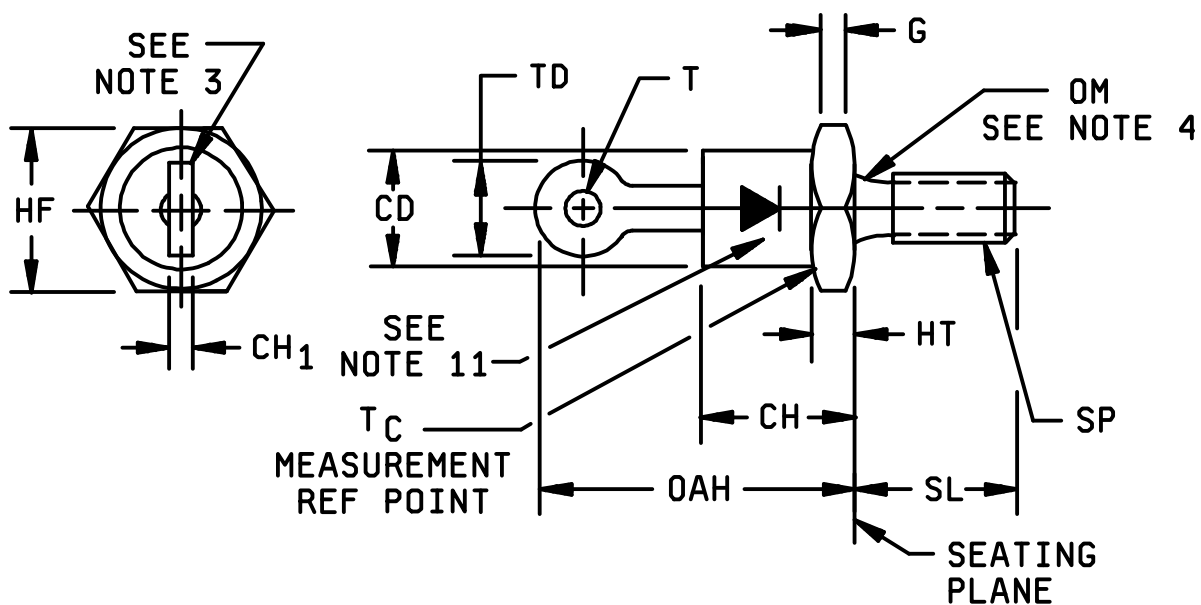

FIGURE 2. Physical dimensions of non-isolated types: 1N3890, 1N3890A, 1N3891, 1N3891A, 1N3893, 1N3893A, 1N3890R, 1N3890AR, 1N3891R, 1N3891AR, 1N3893R, and 1N3893AR (DO-4).

MIL-PRF-19500/304D

Ltr	Dimensions				Notes
	Inches		Millimeters		
	Min	Max	Min	Max	
CD		0.250		6.35	
CH		0.405		10.29	
CH ₁	0.020	0.065	0.51	1.65	9
G	0.060		1.52		
HF	0.424	0.437	10.77	11.10	
HT	0.075	0.175	1.90	4.44	
OAH		0.800		20.32	
OM	0.163	0.189	4.14	4.80	
SL	0.422	0.453	10.72	11.50	
SP					5, 6, 7, 8
T	0.060		1.52		
TD		0.424		10.77	

NOTES:

1. Dimensions are in inches.
2. Metric equivalents are given for general information only.
3. Angular orientation of this terminal is undefined. Square or radius on end of terminals is optional.
4. Diameter variations within these limits are permitted.
5. The ANSI thread reference is 0.190-32 UNF-2A.
6. Max pitch diameter of plated threads shall be basic pitch diameter 0.169 inch (4.29 mm) reference FED-STD-H28 (Screw Thread Standards for Federal Services.)
7. Units must not be damaged by torque of 15 inch-pounds applied to 0.190-32 UNF-2B nut assembled on thread.
8. Complete threads to extend to within 0.078 inch (1.98 mm) of the seating plane.
9. Terminal-end shape is unrestricted.
10. Reversed (anode to stud) units shall be marked with an "R" following the last digit in the type number.
11. Forward polarity (cathode to stud) marking is shown.

FIGURE 2. Physical dimensions of non-isolated types: 1N3890, 1N3890A, 1N3891, 1N3891A, 1N3893, 1N3893A, 1N3890R, 1N3890AR, 1N3891R, 1N3891AR, 1N3893R, and 1N3893AR (DO -4) - Continued.

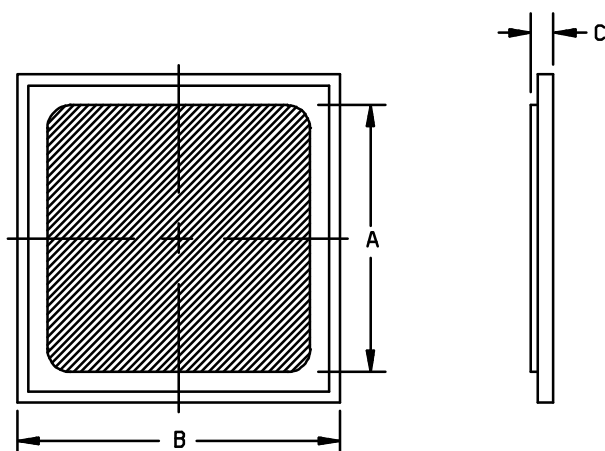

A version

Ltr	Dimensions			
	Inches		Millimeters	
	Min	Max	Min	Max
A	0.114	0.117	2.89	2.97
B	0.130	0.133	3.30	3.37
C	0.009	0.010	0.228	0.254

NOTES:

1. Dimensions are in inches.
2. Metric equivalents are given for general information only.
3. The physical characteristics of the die are: Metallization {front (anode), {back, (cathode) consists of: Ag thickness = 3,000 Å minimum, Ni thickness = 1,500 Å minimum, Cr thickness = 800 Å minimum.
4. Requirements in accordance with MIL-PRF-19500 are performed in a DO-4 package.

FIGURE 3. Physical dimensions JANHC and JANKC.

3.3 Interface requirements and physical dimensions. The Interface requirements and physical dimensions shall be as specified in MIL-PRF-19500 and on figures 1, 2 (DO-4) and 3 (die).

3.3.1 Lead finish. Lead finish shall be solderable in accordance with MIL-PRF-19500. Where a choice of lead finish is desired, it shall be specified in the contract or purchase order (see 6.2).

3.3.2 Diode types 1N3885, 1N3886, and 1N3888 (see figure 1). Diode types 1N3885, 1N3886, and 1N3888 have the stud and seating plane electrically insulated from the anode, cathode, and case.

3.3.3 Diode types 1N3890, 1N3891, and 1N3893 (see figure 2). Diode types 1N3890, 1N3891, and 1N3893 (forward polarity) have the cathode electrically connected to the stud and case.

3.3.4 Diode types 1N3890R, 1N3891R, and 1N3893R (see figure 2). Diode types 1N3890R, 1N3891R, and 1N3893R (reverse polarity) have the anode electrically connected to the stud and case.

3.3.5 Dissimilar construction. Types utilizing construction as shown on figure 1 shall not be considered structurally identical to types utilizing construction as shown in figure 2.

3.4 Marking. Marking shall be in accordance with MIL-PRF-19500.

3.4.1 Polarity. The polarity shall be indicated by a graphic symbol with the arrow pointing toward the negative end for forward bias. The reversed units shall also be marked with an R following the last digit in the type number.

3.5 Electrical performance characteristics. Unless otherwise specified herein, the electrical performance characteristics are as specified in 1.3, 1.4, and table I herein.

3.6 Electrical test requirements. The electrical test requirements shall be the subgroups specified in table I herein.

3.7 Qualification. Devices furnished under this specification shall be products that are authorized by the qualifying activity for listing on the applicable qualified manufacturer's list before contract award (see 4.2 and 6.3).

4. VERIFICATION

4.1 Classification of Inspections. The inspection requirements specified herein are classified as follows:

- a. Qualification inspection (see 4.2).
- b. Screening (see 4.3)
- c. Conformance inspection (see 4.4).

4.2 Qualification inspection. Qualification inspection shall be in accordance with MIL-PRF-19500, and as specified herein. Tests in either polarity shall be sufficient to obtain qualification approval of both polarities.

4.2.1 Qualification for JANHC and JANKC. Qualification for JANHC and JANKC devices shall be in accordance with MIL-PRF-19500.

MIL-PRF-19500/304D

4.3 **Screening.** Screening shall be in accordance with table IV of MIL-PRF-19500, and as specified herein. The following measurements shall be made in accordance with table I herein. Devices that exceed the limits of table I herein shall not be acceptable.

Screen (see table IV of MIL-PRF-19500)	Measurement	
	JANS level	JANTX and JANTXV levels
1/	Surge (see 4.3.1) Thermal response (see 4.3.2)	Surge (see 4.3.1) Thermal response (see 4.3.2)
4	Not applicable	Not applicable
9	V_{F2} and I_{R1} 2/	V_{F2} and I_{R1} 2/
10	MIL-STD-750, method 1038, test condition A, t = 96 hours	MIL-STD-750, method 1038, test condition A, t = 48 hours
11	Subgroup 2 of table I herein, V_{F2} and I_{R1} ; $\Delta V_{F2} = 0.1$ V (pk) from initial value; $\Delta I_{R1} = \pm 5$ μ A dc or 100 percent from the initial value, whichever is greater. 3./	Subgroup 2 of table I herein, V_{F2} and I_{R1} ; $\Delta V_{F2} = 0.1$ V(pk) from initial value; $\Delta I_{R1} = \pm 5$ μ A dc or 100 percent from the initial value, whichever is greater. 3./
12	Burn-in see 4.3.3 and 4.5.2 MIL-STD-750, method 1038, test condition B	Not applicable
13	Subgroup 2 and 3 of table I herein, V_{F2} and I_{R1} ; $\Delta V_{F2} = 0.1$ V (pk); $\Delta I_{R1} = \pm 5$ μ A dc or 100 percent from the initial value, whichever is greater.	Not applicable

1/ Surge shall precede thermal response. These tests shall be performed anytime after screen 3 and before screen 9.

2/ I_{R1} measurement shall not be indicative of an open condition.

3/ PDA of screen 13 shall apply to screen 11.

4.3.1 **Surge current.** Surge current, see MIL-STD-750, method 4066. $I_O = 0$; $V_{RM}(w) = 0$; six surges; $T_A = 25^\circ\text{C}$, $t_p = 8.3$ ms, one surge per minute maximum.

	Surge current value (IFSM)	
	A - version	Non A - version
1N3885	290	190
1N3886	290	190
1N3888	290	190
1N3890, R	310	210
1N3891, R	310	210
1N3893, R	310	210

4.3.2 **Thermal response.** The thermal response measurements shall be performed in accordance with method 3101 of MIL-STD-750 to remove atypical devices. Heating current (I_H) \geq rated I_O ; $t_p = 150$ to 400 ms; $t_{MD} = 50$ to 300 μ s; 50 mA $\leq I_M \leq 250$ mA.

4.3.3 Burn-in and life test. Power burn-in conditions are as follows:MIL-STD-750, method 1038, test condition B. $T_C = 100^\circ\text{C}$, Rated I_O , see 4.5.2

1N3885, 1N3890, 1N3890R	$V_R = 100\text{ V (pk)}$
1N3886, 1N3891, 1N3891R	$V_R = 200\text{ V (pk)}$
1N3888, 1N3893, 1N3893R	$V_R = 400\text{ V (pk)}$

4.3.4 Screening JANHC and JANKC. Screening for JANHC and JANKC shall be in accordance with MIL-PRF-19500 and herein.4.4 Conformance inspection. Conformance inspection shall be in accordance with MIL-PRF-19500, and as specified herein.4.4.1 Group A inspection. Group A inspection shall be conducted in accordance with MIL-PRF-19500, and table I herein.

4.4.2 Group B inspection. Group B inspection shall be conducted in accordance with the conditions specified for subgroup testing in table VIa (JANS) and table VIb (JAN, JANTX, and JANTXV) of MIL-PRF-19500 and paragraphs 4.4.2.1 and 4.4.2.2 herein. Electrical measurements (end-points) shall be in accordance with table I, subgroup 2 herein. Delta measurements shall be in accordance with table II herein.

4.4.2.1 Group B inspection, table VIa (JANS) of MIL-PRF-19500.

<u>Subgroup</u>	<u>Method</u>	<u>Condition</u>
B3	4066	$T_C = 100^\circ\text{C}$; $V_R = \text{Rated } V_R$ (see 1.3), six surges. 1 surge per minute maximum. $t_p = 8.3\text{ ms}$. Non-A version devices, $i_f(\text{surge}) = 150\text{ A}$; $I_O = 12\text{ A dc}$ A version devices, $i_f(\text{surge}) = 225\text{ A}$; $I_O = 20\text{ A dc}$
B4	1037	$0.25\text{ Rated } I_O \leq I_O \text{ applied } \leq \text{Rated } I_O$ (see 4.5.5) 2,000 cycles.
B5	1027	$I_F = 35\text{ A dc}$ at: $T_A = 125^\circ\text{C}$ for 96 hours, or adjusted as required by the chosen T_A to give an average lot $T_J = 275^\circ\text{C}$; $f = 60\text{ Hz}$; $V_R = \text{rated } V_R$ (pk) (see 1.3).
B6	3101	$R_{\theta JC} = \text{rated } R_{\theta JC}$ (see 1.4); $I_M = 50\text{ mA} \leq I_M \leq 250\text{ mA}$; $t_H = 30\text{ s}$ minimum; $t_{MD} = 50 - 300\text{ }\mu\text{s}$.

4.4.2.2 Group B inspection, table VIb (JAN, JANTX and JANTXV) of MIL-PRF-19500.

<u>Subgroup</u>	<u>Method</u>	<u>Condition</u>
B2	1051	Insulated types -65°C to $+150^\circ\text{C}$ Uninsulated types -65°C to $+175^\circ\text{C}$
B2	4066	$T_C = 100^\circ\text{C}$; $V_R = \text{Rated } V_R$ (see 1.3), six surges. 1 surge per minute maximum. $t_p = 8.3\text{ ms}$. Non-A version devices, $i_f(\text{surge}) = 150\text{ A}$; $I_O = 12\text{ A dc}$ A version devices, $i_f(\text{surge}) = 225\text{ A}$; $I_O = 20\text{ A dc}$
B3	1037	$0.25\text{ Rated } I_O \leq I_O \text{ applied } \leq \text{Rated } I_O$ (see 4.5.5) 2,000 cycles.
B3	1038 or 1049	Condition A; 340 hrs.
B5		Not applicable
B6	1032	$T_A = 150^\circ\text{C}$

MIL-PRF-19500/304D

4.4.3 Group C inspection. Group C inspection shall be conducted in accordance with the conditions specified for subgroup testing in table VII of MIL-PRF-19500 and as follows. Electrical measurements (end-points) shall be in accordance with table I, subgroup 2 herein. Delta measurements shall be in accordance with table II herein.

4.4.3.1 Group C inspection, table VII of MIL-PRF-19500.

<u>Subgroup</u>	<u>Method</u>	<u>Condition</u>
C2	1056	Test condition B
C2	2036	Tension, test condition A, t = 15 s. For 1N3885, A, 1N3886, A, 1N3888, A weight = 5 pounds For 1N3890, A, R, AR, 1N3891, A, R, AR, 1N3893, A, R, AR, weight = 20 pounds
C2	2036	Bending stress, test condition F, method B: t = 15 s. For 1N3885, A, 1N3886, A, 1N3888, A weight = 1 pounds For 1N3890, A, R, AR, 1N3891, A, R, AR, 1N3893, A, R, AR weight = 5 pounds
C2	2036	Seal torque test condition D1, torque = 10 oz-inches, t = 15 s.
C5	3101	$R_{\theta JC} = \text{rated } R_{\theta JC}$ (see 1.4); $I_M = 50 \text{ mA} \leq I_M \leq 250 \text{ mA}$; $t_H = 30 \text{ s}$ minimum; $t_{MD} = 50 \text{ to } 300 \mu\text{s}$.
C6	1037	0.25 Rated $I_O \leq I_O$ applied \leq Rated I_O (see 4.5.5) 6,000 cycles.

4.4.4 Group E inspection. Group E inspection shall be conducted in accordance with the conditions specified for subgroup testing in table IX of MIL-PRF-19500, and herein. Electrical measurements (end-points) shall be in accordance with table , subgroup 2 herein. Delta electrical measurements shall be in accordance with table II herein.

4.4.4.1 Group E inspection, table IX of MIL-PRF-19500.

<u>Subgroup</u>	<u>Method</u>	<u>Condition</u>	<u>Sampling plan</u>
E1	1056	0°C to 100°C, 100 cycles.	22 devices, c = 0
E2	1038	Condition A; 1,000 hrs.	22 devices, c = 0
E3	2101	Photos of cross sections shall be submitted In the qualification report. Vendors shall Retain duplicate photos.	3 devices, c = 0
E4	3101	$R_{\theta JC} = \text{rated } R_{\theta JC}$ (see 1.4); $I_M = 50 \text{ mA} \leq I_M \leq 250 \text{ mA}$; $t_H = 30 \text{ s}$ minimum; $t_{MD} = 50 \text{ to } 300 \mu\text{s}$; $I_H \geq \text{rated } I_O$.	22 devices, c = 0
E5	1001	Hg = rated Hg (see 1.3), t = 60 s, while the test is being performed, I_R shall be monitored and shall not exceed 25 μA dc. $T_C = 25^\circ\text{C}$.	

4.5 Methods of inspection. Methods of inspection shall be as specified in the appropriate tables and as follows.

4.5.1 Pulse measurements. Conditions for pulse measurement shall be as specified in section 4 of MIL-STD-750.

4.5.2 Burn-in and steady-state operation life tests. These tests shall be conducted with a half-sine waveform of the specified peak voltage impressed across the diode in the reverse direction followed by a half-sine waveform of the specified average rectifier current. The forward conduction angle of the rectified current shall not be greater than 180° nor less than 150°.

4.5.3 Insulation resistance (case-to-stud). The case –to-stud insulation resistance shall be determined in terms of current flow between the case and stud. The specified test method shall be utilized except that the applied voltage shall be within ± 2.0 percent of the specified value and the current shall be measured by a series microammeter with a voltage drop at $1.0 \mu\text{A}$ dc of less than 1.0 V dc, and an accuracy of ± 2.0 percent at the $1.0 \mu\text{A}$ dc point.

4.5.4 Reverse recovery time. The reverse recovery time shall be measured in the circuit of figure 5 or equivalent. Care should be exercised to minimize stray inductances in the test circuit and to insure that the total resistance of the reverse current loop can be adjusted sufficiently low so that more than 2 amperes will flow if not blocked by the diode being tested. Switch SW shall be activated and the regulated voltage adjusted to achieve the specified forward current when SW is open. Indicator L and resistor R shall be adjusted to achieve the following characteristics of the waveform:

- a. The di/dt shall be the specified value between the forward 0.5 ampere point and the reverse 0.2 ampere point.
- b. The $I_{R(\text{rec})}$ shall be the maximum value obtainable, except that if it exceeds 2 amperes, it shall be reduced to equal 2 amperes.

The reverse recovery time shall then be determined from the current waveform as shown in figure 5.

4.5.5 DC intermittent operation life. A cycle shall consist of an "on" period, when power is applied suddenly, not gradually, to the device for the time necessary to achieve a delta case temperature of 85°C , $+ 15^\circ\text{C}$, $- 5^\circ\text{C}$, followed by an "off" period, when the power is suddenly removed, for cooling. Auxiliary (forced) cooling is permitted during the off period only.

$t_{\text{heating}} \leq 5$ minutes. $P = V_F \times I_F$ or $P = V_{F(\text{pk})} \times I_{\text{av}}$ if using sine wave current. DC full wave current shall be used for the power required during the "on" period (or equivalent half sine wave current).

Within the time interval of 50 cycles before to 500 cycles after the termination of the test, the sample units shall be removed from the specified test conditions and allowed to reach room ambient test conditions. Specified end-point measurements for qualification and conformance inspection shall be completed within 96 hours after removal of sample units from the specified test conditions. Additional readings may be taken at the discretion of the manufacturer.

TABLE I. Group A inspection.

Inspection <u>1/</u>	MIL-STD-750		Symbol	Limits		Unit
	Method	Conditions		Min	Max	
<u>Subgroup 1</u>						
Visual and mechanical Inspection	2071					
<u>Subgroup 2</u>						
Forward voltage	4011	$t_p < 8.3$ ms, duty cycle ≤ 2 percent pulse $I_F = 38$ A(pk)	V_{F2}		1.5	V dc
Reverse current	4016	DC method $V_R = \text{Rated } V_R$ (see 1.3)	I_{R1}		10	$\mu\text{A dc}$
Insulation resistance (case to stud) applicable only to 1N3885, 1N3885A 1N3886, 1N3886A 1N3888, 1N3888A	1016	Test condition C, See 4.5.3	R_{ISO}	10^9		Ohms
<u>Subgroup 3</u>						
High temperature operation:		$T_A = T_C = 150^\circ\text{C}$				
Reverse current	4016	DC method $V_R = \text{Rated } V_R(\text{pk})$ (see 1.3)	I_{R2}		2	mA dc
<u>Subgroups 4 and 5</u>						
Not applicable						
<u>Subgroup 6 <u>2/</u></u>						
Forward voltage	4011	$I_F = I_{f(\text{surge})}$; $t_p = 800$ μs	V_{F1}		2.75	V dc
Forward voltage	4011	$I_F = I_{f(\text{surge})}$; $t_p = 8.3$ ms	V_{F1}		2.55	V dc
<u>Subgroup 7</u>						
Reverse recovery time	4031	$T_C = 55^\circ\text{C}$; $I_F = 1$ A dc; $V_R = 30$ V dc, $di/dt = -25$ A/ μs ; $I_{r(\text{rec})} \leq 2$ A (pk) (see 4.5.4)	t_{rr}			
Non A A-versions					200 150	

1/ For sampling plan, see MIL-PRF-19500.2/ V_{F1} shall be performed with either $t_p = 800$ μs or $t_p = 8.3$ ms.

TABLE II. Groups B and C delta electrical measurements. 2/ 3/ 4/ 5/

Step	Inspection	MIL-STD-750		Symbol	Limits		Unit
		Method	Conditions		Min	Max	
1	Thermal response	3101	See 4.3.2, $R_{\theta JC}$ = rated $R_{\theta JC}$ (see 1.4);	ΔV_F			mV dc
2.	Forward voltage	4011	$I_F = 50$ mA dc	ΔV_{F3}	+ 50 mV dc maximum change from previous to post intermittent life and thermal shock measurement tests (JANS only).		
3.	Reverse current	4016	DC method $V_R =$ Rated V_R (dc) (see 1.3)	ΔI_{R1} <u>1/</u>	100 percent or $\pm 5 \mu A$, (whichever is greater) change from initial group A reading.		

1/ Devices which exceed the group A limits for this test shall be rejected.

2/ The delta measurements for table VIa (JANS) of MIL-PRF-19500 are as follows:

- a. Subgroup 3, see table II herein, steps 1 and 2.
- b. Subgroup 4, see table II herein, steps 1 and 2.
- c. Subgroup 5, see table II herein, step 3.

3/ The delta measurements for table VIb (JAN, JANTX and JANTXV) of MIL-PRF-19500 are as follows:

- a. Subgroup 3, see table II herein, step 1.

4/ The delta electrical measurements for table VII of MIL-PRF-19500 are as follows:

- a. Subgroup 2 see table II herein, step 1.
- b. Subgroup 6, see table II herein, steps 1 and 3 (JANS); and step 1 (JAN, JANTX and JANTXV).

5/ The delta electrical measurements for table IX of MIL-PRF-19500 are as follows:

- a. Subgroup 1 see table II herein, step 1.
- b. Subgroup 2 see table II herein, step 3.

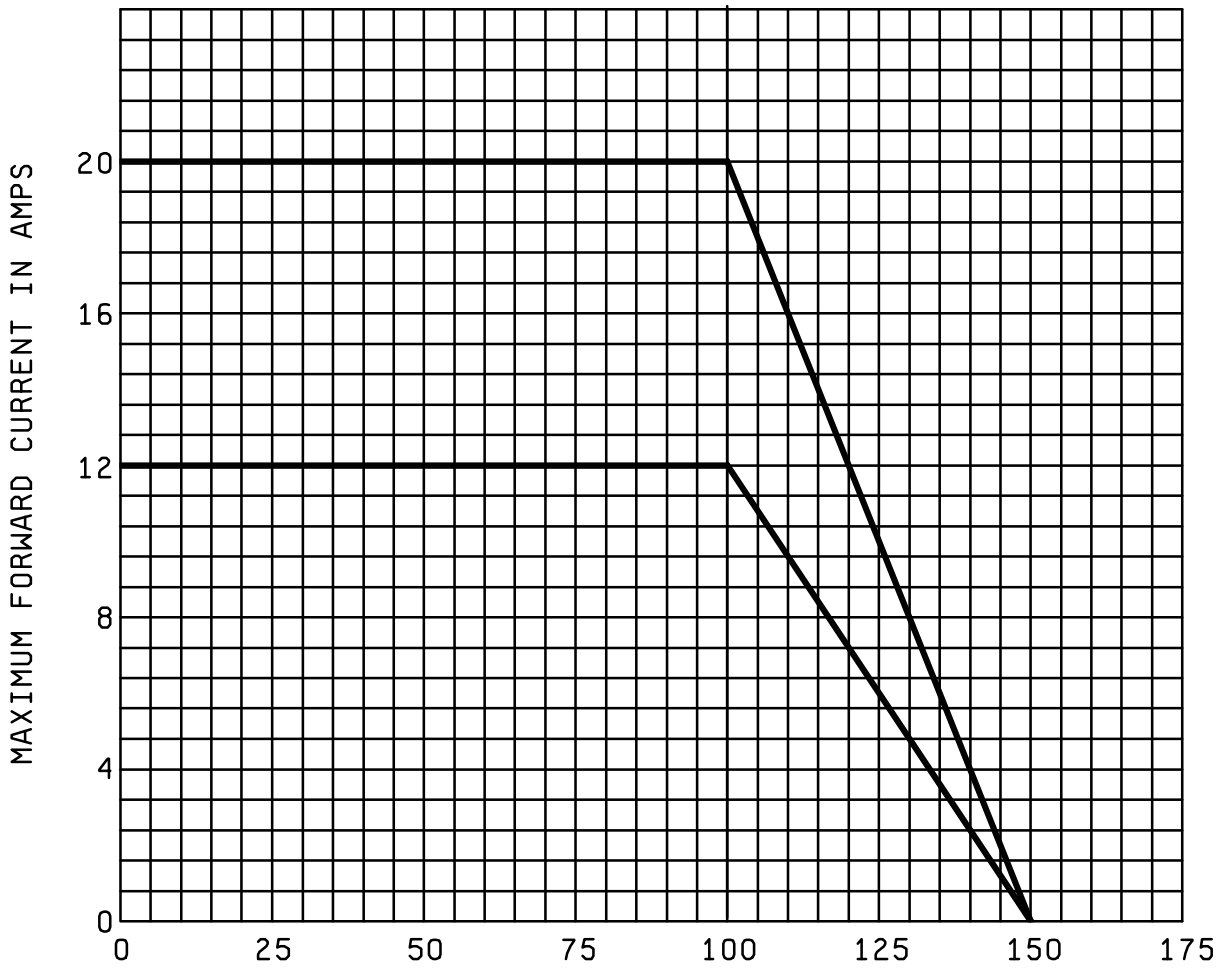
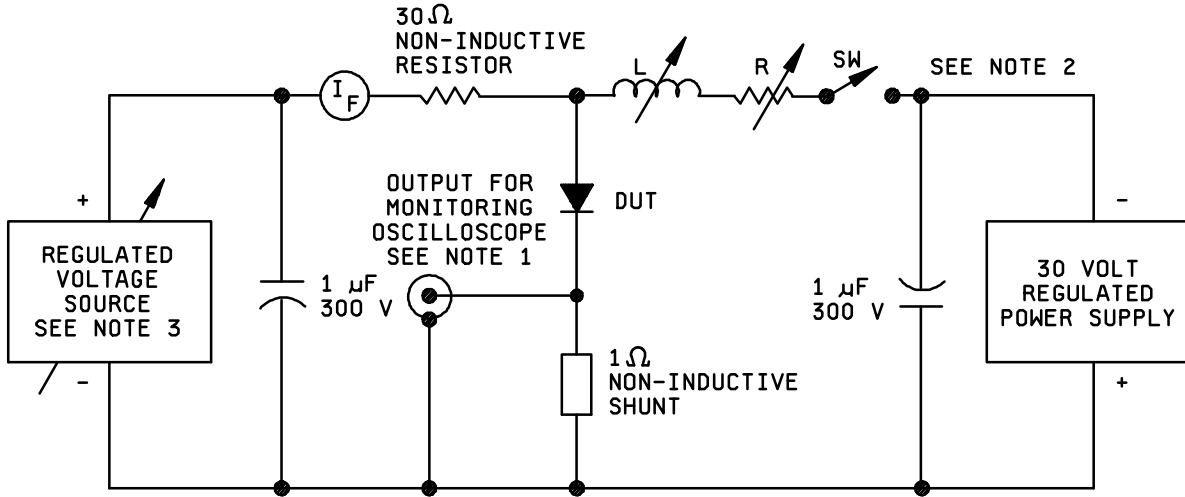

FIGURE 4. Maximum case temperature in °C.



NOTES:

1. Monitoring oscilloscope requirements: $t_r \leq 14$ ns, $R_{in} \geq 9$ M Ω , $C_{in} \leq 12$ pF, L_{in} (series) ≤ 0.5 μ H.
2. SW characteristics: Mercury-wetted make-before break relay switched at a 60 Hz rate. The relay should conduct for approximately 640 μ s and be open for approximately 7.7 ms. (C.P. Clare HGP 1004 or equivalent).
3. Voltage source characteristics: Output impedance ≤ 0.5 Ω from 0 to 2 kHz.

FIGURE 5. Reverse recovery test circuit.

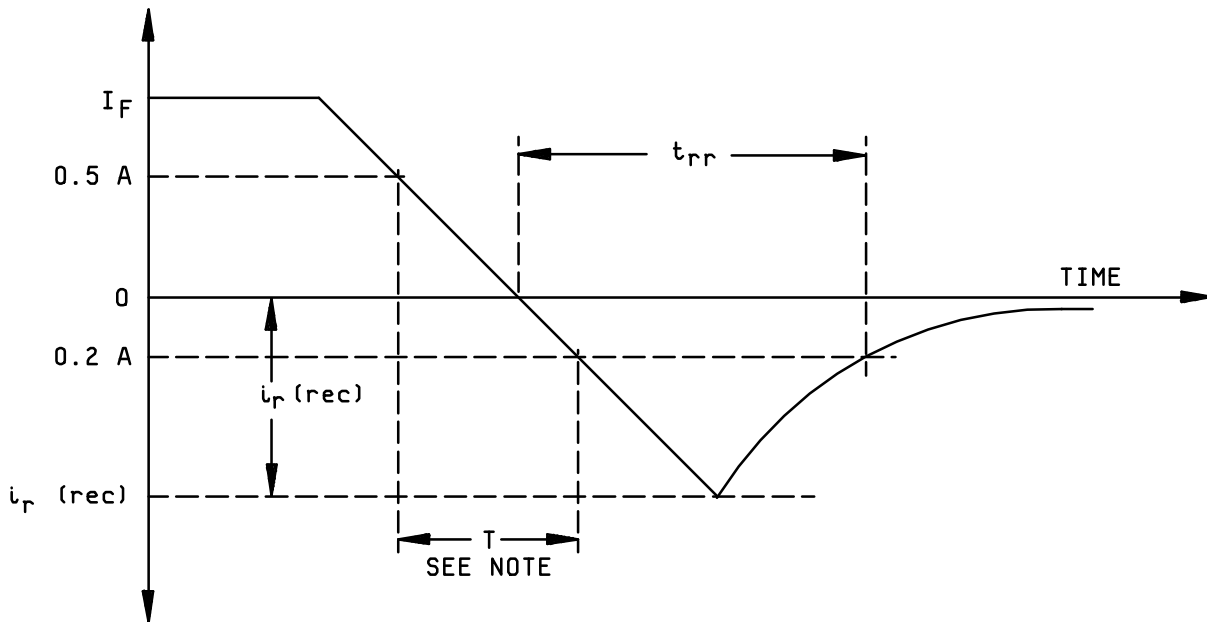

NOTE:

*Adjust L and R in accordance with 4.5.4 to achieve $T = 0.028$ μ s, ($L \approx 1.2$ μ H). Then $di/dt = -0.7/0.028 = -25A/\mu$ s.

FIGURE 6. Reverse recovery current waveform through device under test.

5. PACKAGING

5.1 Packaging. For acquisition purposes, the packaging requirements should be as specified in the contract or order (see 6.2). When actual packaging of material is to be performed by DoD personnel, these personnel need to contact the responsible packaging activity to ascertain requisite packaging requirements. Packaging requirements are maintained by the Inventory Control Points' packaging activity within the Military Department or Defense Agency, or within the Military Departments' System Command. Packaging data retrieval is available from the managing Military Departments' or Defense Agency's automated packaging files, CD-ROM products, or by contacting the responsible packaging activity.

6. NOTES

(This section contains information of a general or explanatory nature that may be helpful, but is not mandatory.)

6.1 Notes. The notes specified in MIL-PRF-19500 are applicable to this specification.

6.2 Acquisition requirements. Acquisition documents must specify the following:

- a. Issue of DODISS to be cited in the solicitation (see 2.1.1).
- b. The lead finish as specified (see 3.3.1).
- c. Type designation and quality assurance level.
- d. Packaging requirements (see 5.1).
- e. For die acquisition, the letter version must be specified (see figure 3).

6.3 Qualification. With respect to products requiring qualification, awards will be made only for products which are, at the time of award of contract, qualified for inclusion in Qualified Manufacturer's List QML-19500 whether or not such products have actually been so listed by that date. The attention of the contractors is called to these requirements, and manufacturers are urged to arrange to have the products that they propose to offer to the Federal Government tested for qualification in order that they may be eligible to be awarded contracts or purchase orders for the products covered by this specification. Information pertaining to qualification of products may be obtained from Defense Supply Center Columbus, DSCC-VQE, Columbus, OH 43216.

6.4 Supersession data. The following types were superseded through a previous revision of this specification and the cancellation of MIL-S-19500/266. A-version devices may be substituted for Non A-version devices. Applicable substitutes are as follows:

Superseded types	Substitute types
1N3874, 1N3875, 1N3884	1N3885
1N3876	1N3886
1N3877, 1N3878, 1N3887	1N3888
1N3879, 1N3880, 1N3889	1N3890
1N3879R, 1N3880R, 1N3889R	1N3890R
1N3881	1N3891
1N3881R	1N3891R
1N3882, 1N3883, 1N3892	1N3893
1N3882R, 1N3883R, 1N3892R	1N3893R

Note: Superseded types will not be used for new design.

6.5 Suppliers of JANHC and JANKC die. The qualified JANHC and JANKC suppliers with the applicable letter version (example JANHCA1N3885) will be identified on the QML.

JANHC and JANKC ordering information	
PIN ^{1/}	Manufacturer
	59377
1N3885	JANHCA1N3885
1N3886	JANHCA1N3886
1N3888	JANHCA1N3888
1N3890	JANHCA1N3890
1N3891	JANHCA1N3891
1N3893	JANHCA1N3893

^{1/} Also applies to "A" suffix devices.

^{2/} For JANS level, replace "JANHC" prefix with "JANKC".

6.6 Changes from previous issue. Marginal notations are not used in this revision to identify changes with respect to the previous issue due to the extensiveness of the changes.

Custodians:
 Army - CR
 Navy - EC
 Air Force - 11
 NASA - NA
 DLA - CC

Preparing activity:
 DLA - CC
 (Project 5961-2130)

Review activities:
 Army - AR, MI, SM
 Navy - AS, CG, MC
 Air Force - 19

STANDARDIZATION DOCUMENT IMPROVEMENT PROPOSAL

INSTRUCTIONS

1. The preparing activity must complete blocks 1, 2, 3, and 8. In block 1, both the document number and revision letter should be given.
2. The submitter of this form must complete blocks 4, 5, 6, and 7.
3. The preparing activity must provide a reply within 30 days from receipt of the form.

NOTE: This form may not be used to request copies of documents, nor to request waivers, or clarification of requirements on current contracts. Comments submitted on this form do not constitute or imply authorization to waive any portion of the referenced document(s) or to amend contractual requirements.

I RECOMMEND A CHANGE:	1. DOCUMENT NUMBER	2. DOCUMENT DATE
	MIL-PRF-19500/304D	990815

3. **DOCUMENT TITLE**
 SEMICONDUCTOR DEVICE, DIODE, SILICON, POWER RECTIFIER, FAST RECOVERY TYPES 1N3885, 1N3886, 1N3888, 1N3890, 1N3891, 1N3893, 1N3890R, 1N3891R, 1N3893R AND A-VERSIONS JAN, JANTX, JANTXV, JANS, JANHC AND JANKC

4. NATURE OF CHANGE (Identify paragraph number and include proposed rewrite, if possible. Attach extra sheets as needed.)

5. REASON FOR RECOMMENDATION

6. SUBMITTER

a. NAME (Last, First, Middle initial)	b. ORGANIZATION	
c. ADDRESS (Include Zip Code)	d. TELEPHONE (Include Area Code)	7. DATE SUBMITTED
	COMMERCIAL DSN FAX EMAIL	

8. PREPARING ACTIVITY

a. Point of Contact Alan Barone	b. TELEPHONE	
	Commercial DSN FAX EMAIL	
	614-692-0510 850-0510 614-692-6939 alan_barone@dsccl.dla.mil	
c. ADDRESS Defense Supply Center Columbus, ATTN: DSCC-VAC, 3990 East Broad Street, Columbus, OH 43216-5000	IF YOU DO NOT RECEIVE A REPLY WITHIN 45 DAYS, CONTACT: Defense Standardization Program Office (DLSC-LM) 8725 John J. Kingman, Suite 2533, Fort Belvoir, VA 22060-6221 Telephone (703) 767-6888 DSN 427-6888	