

**PUSH-PULL FOUR CHANNEL/DUAL  
H-BRIDGE DRIVER**

PRELIMINARY DATA

- 600 mA OUTPUT CURRENT CAPABILITY PER CHANNEL
- 1.2 A PEAK OUTPUT CURRENT (non repetitive) PER CHANNEL
- ENABLE FACILITY
- OVERTEMPERATURE PROTECTION
- LOGICAL "0" INPUT VOLTAGE UP TO 1.5 V (high noise immunity)
- SEPARATE HIGH VOLTAGE POWER SUPPLY (up to 44 V)

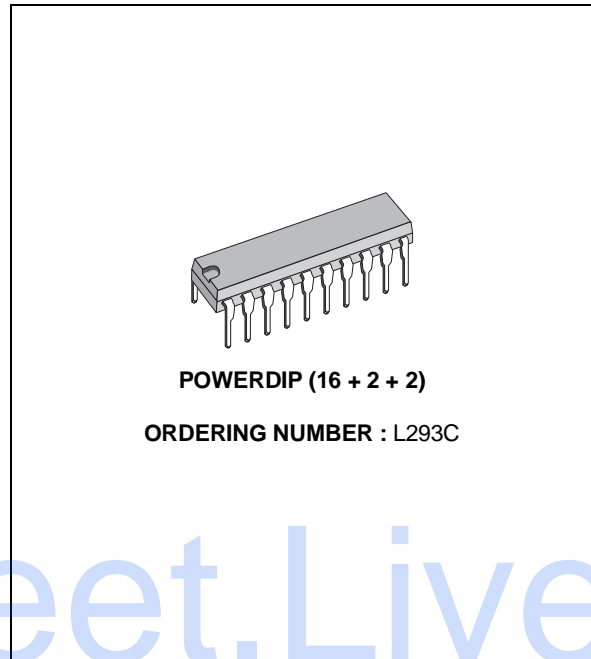

Datasheet.Live

**DESCRIPTION**

The L293C is a monolithic high voltage, high current integrated circuit four channel driver in a 20 pin DIP. It is designed to accept standard TTL or DTL input logic levels and drive inductive loads (such as relays, solenoids, DC and stepping motors) and switching power transistors.

The device may easily be used as a dual H-bridge driver : separate chip enable and high voltage power supply pins are provided for each H-bridge. In addition, a separate power supply is provided for the logic section of the device.

The L293C is assembled in a 20 lead plastic package which has 4 center pins connected together and used for heatsinking.

**PIN CONNECTION**

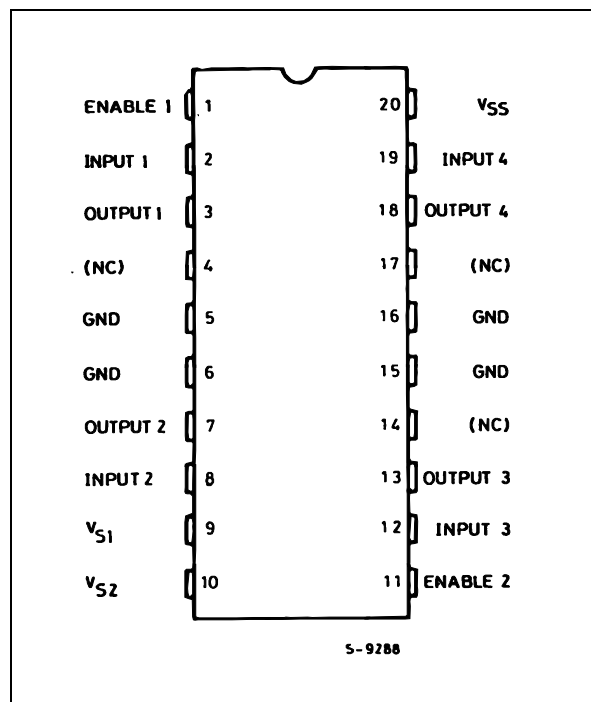

# L293C

## BLOCK DIAGRAM

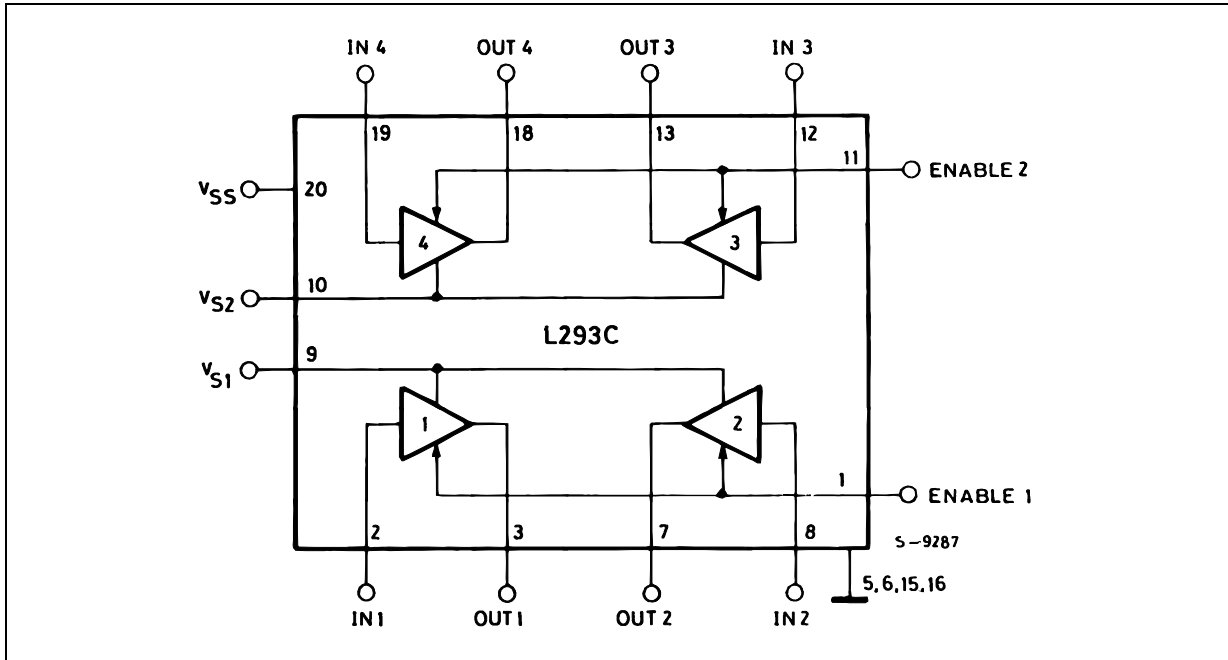

## TRUTH TABLE

Input	Enable	Output
H	H	H
L	H	L
X	L	Z

Z = High output impedance

## SWITCHING TIMES

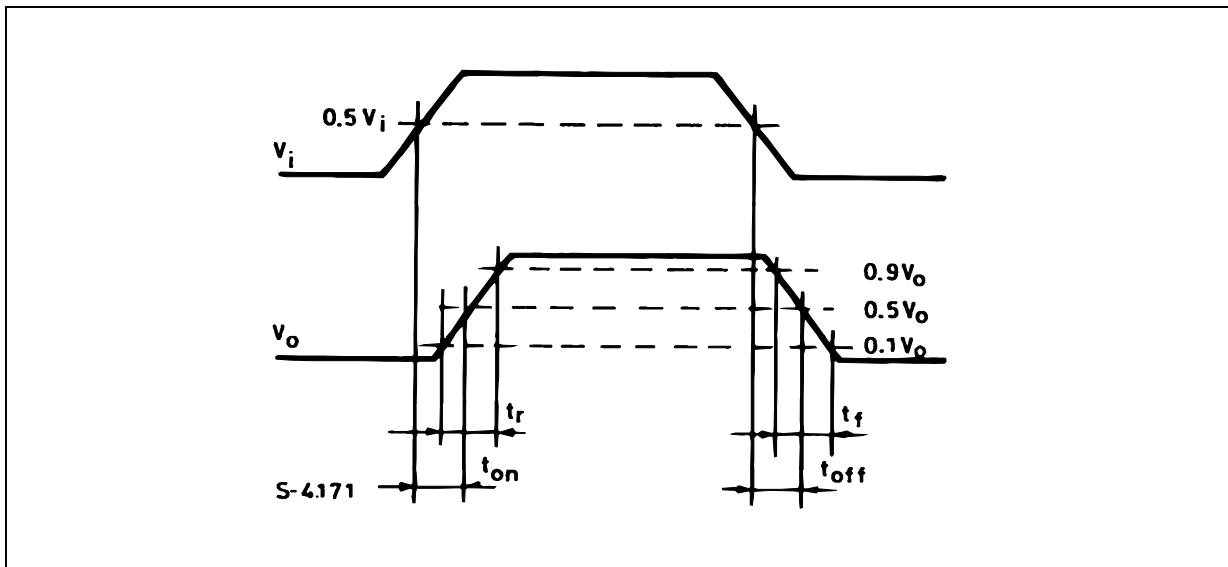

**ABSOLUTE MAXIMUM RATINGS**

Symbol	Parameter	Value	Unit
$V_S$	Supply Voltage	50	V
$V_{SS}$	Logic Supply Voltage	7	V
$V_i$	Input Voltage	7	V
$V_{EN}$	Enable Voltage	7	V
$I_{out}$	Peak Output Current (non-repetitive $t = 5$ ms)	1.2	A
$P_{tot}$	Total Power Dissipation at $T_{ground-pins} = 80^\circ\text{C}$	5	W
$T_{stg}, T_j$	Storage and Junction Temperature	-40 to 150	$^\circ\text{C}$

**THERMAL DATA**

Symbol	Parameter	Value	Unit
$R_{th\ j-case}$	Thermal Resistance Junction-case	Max. 14	$^\circ\text{C}/\Omega$
$R_{th\ j-amb}$	Thermal Resistance Junction-ambient	Max. 80	$^\circ\text{C}/\Omega$

**ELECTRICAL CHARACTERISTICS**

(for each channel,  $V_S = 24$  V,  $V_{SS} = 5$  V,  $T_{amb} = 25^\circ\text{C}$ , unless otherwise specified)

Symbol	Parameter	Test Conditions	Min.	Typ.	Max.	Unit
$V_S$	Supply Voltage (pin 9, 10)		$V_{SS}$		44	V
$V_{SS}$	Logic Supply Voltage (pin 20)		4.5		7	V
$I_S$	Total Quiescent Supply Current (pin 9, 10)	$V_i = L$ $I_O = 0$ $V_{EN} = H$ $V_i = H$ $I_O = 0$ $V_{EN} = H$ $V_{EN} = L$		2 16	6 24 4	mA
$I_{SS}$	Total Quiescent Logic Supply Current (pin 20)	$V_i = L$ $I_O = 0$ $V_{EN} = H$ $V_i = H$ $I_O = 0$ $V_{EN} = H$ $V_{EN} = L$		44 16 16	60 22 24	mA
$V_{IL}$	Input Low Voltage (pin 2, 8, 12, 19)		-0.3		1.5	V
$V_{IH}$	Input High Voltage (pin 2, 8, 12, 19)		2.3		$V_{SS}$	V
$I_{iL}$	Low Voltage Input Current (pin 2, 8, 12, 19)	$V_i = 1.5$ V			-10	$\mu\text{A}$
$I_{iH}$	High Voltage Input Current (pin 2, 8, 12, 19)	$2.3\text{ V} \leq V_i \leq V_{SS} - 0.6\text{ V}$		30	100	$\mu\text{A}$
$V_{EN\ L}$	Enable Low Voltage (pin 1, 11)		-0.3		1.5	V
$V_{EN\ H}$	Enable High Voltage (pin 1, 11)		2.3		$V_{SS}$	V
$I_{EN\ L}$	Low Voltage Enable Current (pin 1, 11)	$V_{EN\ L} = 1.5$ V		-30	-100	$\mu\text{A}$
$I_{EN\ H}$	High Voltage Enable Current (pin 1, 11)	$2.3\text{ V} \leq V_{EN\ H} \leq V_{SS} - 0.6$			$\pm 10$	$\mu\text{A}$
$V_{CE(sat)H}$	Source Output Saturation Voltage (pins 3, 7, 13, 18)	$I_O = -0.6$ A		1.4	1.8	V
$V_{CE(sat)L}$	Sink Output Saturation Voltage (pins 3, 7, 13, 18)	$I_O = +0.6$ A		1.2	1.8	V
$t_r$	Rise Time (*)	$0.1$ to $0.9\ V_O$		250		ns
$t_f$	Fall Time (*)	$0.9$ to $0.1\ V_O$		250		ns
$t_{on}$	Turn-on Delay (*)	$0.5\ V_i$ to $0.5\ V_O$		750		ns
$t_{off}$	Turn-off Delay (*)	$0.5\ V_i$ to $0.5\ V_O$		200		ns

(\*) See switching times diagram

# L293C

## POWERDIP (16 + 2 +2) PACKAGE MECHANICAL DATA

Dimensions	Millimeters			Inches		
	Min.	Typ.	Max.	Min.	Typ.	Max.
a1	0.51			0.020		
B	0.85		1.4	0.033		0.055
b		0.5			0.020	
b1	0.38		0.5	0.015		0.020
D			24.8			0.976
E		8.8			0.346	
e		2.54			0.100	
e3		22.86			0.900	
F			7.1			0.280
i			5.1			0.201
L		3.3			0.130	
Z			1.27			0.050

DIP20PW.TBL

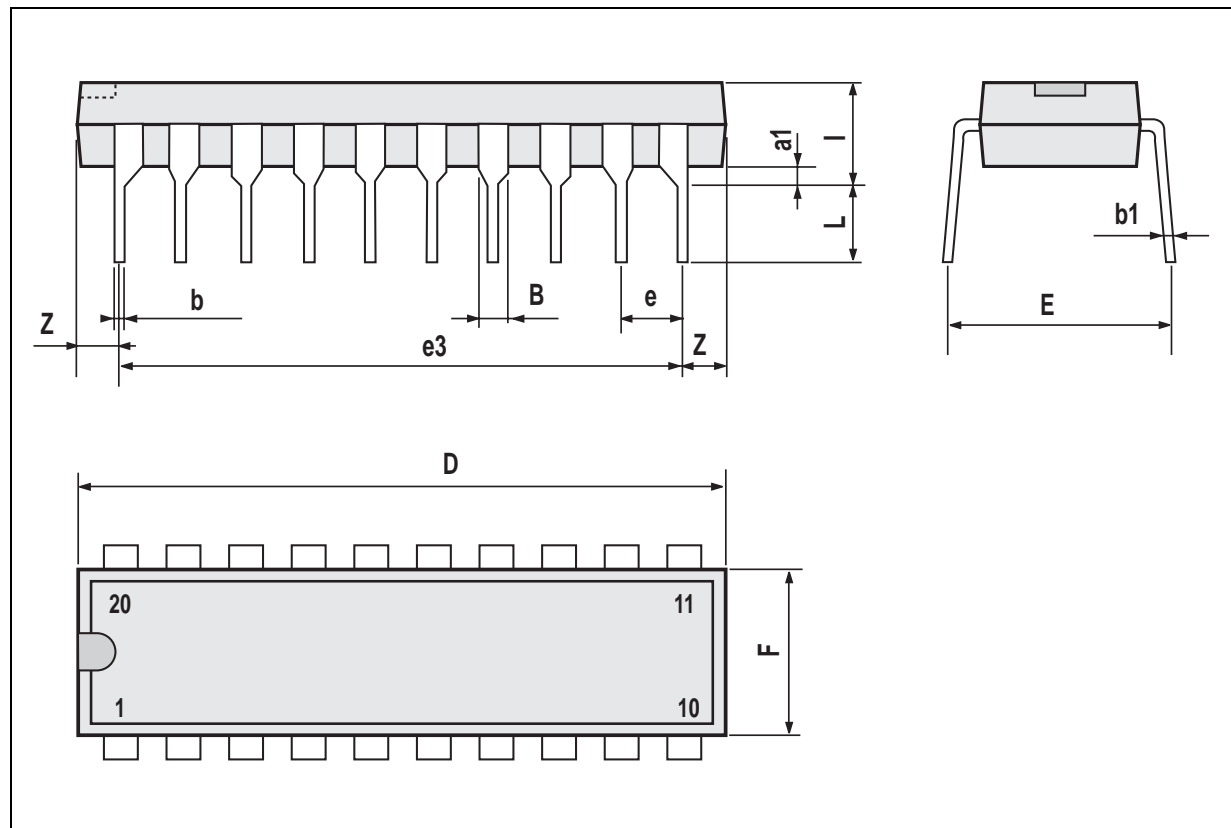

PMDIP20W.EPS

Information furnished is believed to be accurate and reliable. However, SGS-THOMSON Microelectronics assumes no responsibility for the consequences of use of such information nor for any infringement of patents or other rights of third parties which may result from its use. No license is granted by implication or otherwise under any patent or patent rights of SGS-THOMSON Microelectronics. Specifications mentioned in this publication are subject to change without notice. This publication supersedes and replaces all information previously supplied. SGS-THOMSON Microelectronics products are not authorized for use as critical components in life support devices or systems without express written approval of SGS-THOMSON Microelectronics.

© 1994 SGS-THOMSON Microelectronics - All Rights Reserved  
SGS-THOMSON Microelectronics GROUP OF COMPANIES

Australia - Brazil - France - Germany - Hong Kong - Italy - Japan - Korea - Malaysia - Malta - Morocco - The Netherlands - Singapore - Spain - Sweden - Switzerland - Taiwan - Thailand - United Kingdom - U.S.A.