

**GENERAL DESCRIPTION**

The LM105 series are positive voltage regulators, each constructed on a silicon chip by the planar epitaxial process.

They are similar to the LM100, except for an extra gain stage to improve regulation. In both linear and switching regulator circuits with outputs greater than 4.5V, these devices are direct plug-in replacements for the LM100.

The LM105 military version operates from  $-55^{\circ}\text{C}$  to  $+125^{\circ}\text{C}$ . The LM305/LM305A are commercial versions which operate from  $0^{\circ}\text{C}$  to  $+70^{\circ}\text{C}$ .

These regulators feature fast response to load and line transients, freedom from oscillations with varying resistive and reactive loads, and reliable starts on any load within ratings.

The LM205 is the same as the LM105 except its performance is guaranteed from  $-25^{\circ}\text{C}$  to  $+85^{\circ}\text{C}$ .

**DESIGN FEATURES**

- Output Voltage Adjustable from 4.5V to 40V
- Output Currents in Excess of 10A by Adding External Transistors
- Load Regulation Better Than 0.1%, Full Load With Current Limiting
- DC Line Regulation Guaranteed at 0.03%/V
- Ripple Rejection of 0.01%/V
- 45mA Output Current Without External Pass Transistor

**SCHEMATIC DIAGRAM**

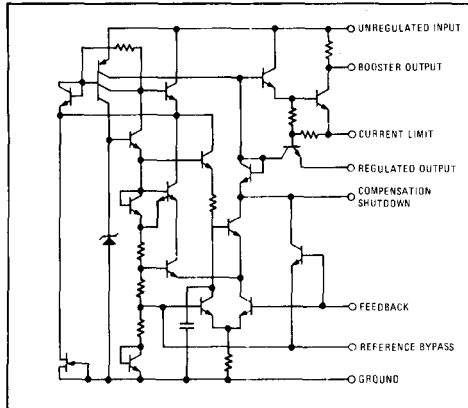

**CONNECTION INFORMATION**

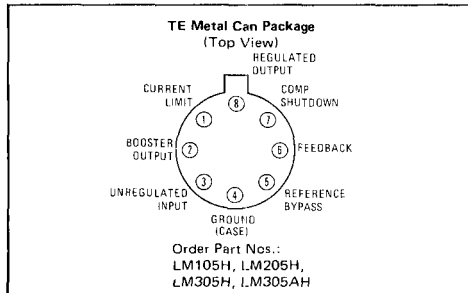

**TYPICAL APPLICATIONS**

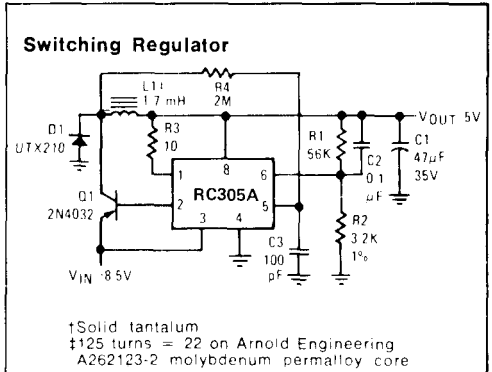

**10A Regulator with Foldback Current Limiting**

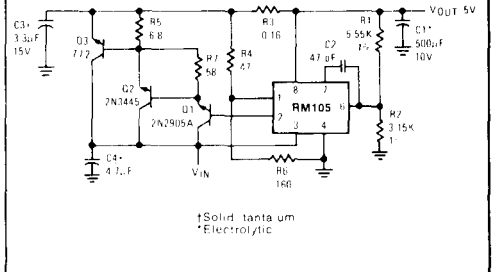

**Positive Voltage Regulators**

**ABSOLUTE MAXIMUM RATINGS**

Input Voltage . . . . .	LM105, LM205, LM305A: 50V LM305: 40V	Operating Temperature Range LM105 . . . . . -55°C to +150°C LM205 . . . . . -25°C to +85°C LM305/305A . . . . . 0°C to +70°C
Input-Output Voltage Differential . . . . .	40V	Storage Temperature Range . . . . . -65°C to +150°C
Power Dissipation (Note 1) LM105, LM205, LM305A . . . . .	800mW	Lead Temperature (Soldering, 10s) . . . . . 300°C
LM305 . . . . .	500mW	

**ELECTRICAL CHARACTERISTICS** (Note 2)

PARAMETER		CONDITIONS	MIN	TYP	MAX	UNITS
Input Voltage Range	LM105/205/305A		8.5		50	V
	LM305		8.5		40	
Output Voltage Range	LM105/205/305A		4.5		40	V
	LM305		4.5		30	
Output-Input Voltage Differential			3.0		30	V
Load Regulation (Note 3)	LM105	$0 \leq I_O \leq 12\text{mA}$				%
		$R_{SC} = 10\Omega, T_A = 25^\circ\text{C}$		0.02	0.05	
		$R_{SC} = 10\Omega, T_A = 125^\circ\text{C}$		0.03	0.1	
		$R_{SC} = 10\Omega, T_A = -55^\circ\text{C}$		0.03	0.1	
	LM205	$0 \leq I_O \leq 12\text{mA}$				%
		$R_{SC} = 10\Omega, T_A = 25^\circ\text{C}$		0.02	0.05	
		$R_{SC} = 10\Omega, T_A = 85^\circ\text{C}$		0.03	0.1	
		$R_{SC} = 10\Omega, T_A = -25^\circ\text{C}$		0.03	0.1	
	LM305A	$0 \leq I_O \leq 45\text{mA}$				%
		$R_{SC} = 0\Omega, T_A = 25^\circ\text{C}$		0.02	0.2	
		$R_{SC} = 0\Omega, T_A = 70^\circ\text{C}$		0.03	0.4	
		$R_{SC} = 0\Omega, T_A = 0^\circ\text{C}$		0.03	0.4	
LM305	$0 \leq I_O \leq 12\text{mA}$				%	
	$R_{SC} = 10\Omega, T_A = 25^\circ\text{C}$		0.02	0.05		
	$R_{SC} = 15\Omega, T_A = 70^\circ\text{C}$		0.03	0.1		
	$R_{SC} = 10\Omega, T_A = 0^\circ\text{C}$		0.03	0.1		
Line Regulation		$V_{IN} - V_{OUT} \leq 5\text{V}$ $V_{IN} - V_{OUT} > 5\text{V}$		0.025 0.015	0.06 0.03	%/V
Ripple Rejection		$C_{REF} = 10\mu\text{F}, F = 120\text{Hz}$		0.003	0.01	%/V
Temperature Stability	LM105	$-55^\circ\text{C} \leq T_A \leq 125^\circ\text{C}$		0.3	1.0	%
	LM205	$-25^\circ\text{C} \leq T_A \leq 85^\circ\text{C}$		0.3	1.0	
	LM305/LM305A	$0^\circ\text{C} \leq T_A \leq 70^\circ\text{C}$		0.3	1.0	
Current Limit Sense Voltage (Note 4)		$R_{SC} = 10\Omega, T_A = 25^\circ\text{C}, V_{OUT} = 0\text{V}$	225	300	375	mV
Feedback Sense Voltage	LM105/205/305		1.63	1.7	1.81	V
	LM305A		1.55	1.7	1.85	
Output Noise Voltage	$10\text{Hz} \leq f \leq 10\text{kHz}$					%
	$C_{REF} = 0$			0.005		
	$C_{REF} > 0.1\mu\text{F}$			0.002		
Standby Current Drain	LM305	$V_{IN} = 40\text{V}$		0.8	2.0	mA
	LM105/205/305A	$V_{IN} = 50\text{V}$		0.8	2.0	
Long Term Stability				0.1	1.0	%

**NOTES:**

- The maximum junction temperature of the LM105 is 150°C and 85°C for the LM305. For operating at elevated temperatures, devices in the TO-5 package must be derated based on a thermal resistance of 150°C/W junction to ambient, or 45°C/W junction to case. For the flat package, the derating is based on a thermal resistance of 185°C/W when mounted on a 1/16-inch thick epoxy glass board with ten, 0.03-inch-wide, 2-ounce copper conductors. Peak dissipations to 1W are allowable providing the dissipation rating is not exceeded with the power averaged over a five second interval, for the LM105, and averaged over a two second interval for the LM305.
- These specifications apply for input and output voltages within the ranges given, and for a divider impedance seen by the feedback terminal of 2kΩ, unless otherwise specified. The load and line regulation specifications are for constant junction temperature. Temperature drift effects must be taken into account separately when the unit is operating under conditions of high dissipation.
- The output currents given, as well as the load regulation, can be increased by the addition of external transistors. The improvement factor will be roughly equal to the composite current gain of the added transistors.
- No external pass transistor.

