

Service
Service
Service



Service Manual

Horizontal Frequency
31~60 kHz

TABLE OF CONTENTS

Description	Page	Description	Page
Table Of Contents.....	1	6.1.Main Board.....	25
Important Safety Notice.....	2	6.2.Power Board.....	28
Revision List.....	3	6.3.Key Board.....	29
1. General Specification.....	4	6.4 IR Board.....	29
2. Operating Instructions.....	6	7. Adjustment.....	30
2.1. The Use Of Remote Control.....	6	8. Block Diagram.....	31
2.2. To Use The Menu.....	7	9. Schematic.....	32
2.3. How To Connect.....	13	9.1 Main Board.....	32
2.4. Front Panel Control Knobs.....	14	9.2.Power Board.....	46
3. Input/Output Specification.....	15	9.3.Key Board.....	47
4. Mechanical Instructions.....	17	10. Exploded View.....	48
5. Repair Flow Chart.....	20	11. BOM List.....	50
6. PCB Layout.....	25		

SAFETY NOTICE

ANY PERSON ATTEMPTING TO SERVICE THIS CHASSIS MUST FAMILIARIZE HIMSELF WITH THE CHASSIS AND BE AWARE OF THE NECESSARY SAFETY PRECAUTIONS TO BE USED WHEN SERVICING ELECTRONIC EQUIPMENT CONTAINING HIGH VOLTAGES.

CAUTION: USE A SEPARATE ISOLATION TRANSFORMER FOR THIS UNIT WHEN SERVICING

Important Safety Notice

Proper service and repair is important to the safe, reliable operation of all AOC Company Equipment. The service procedures recommended by AOC and described in this service manual are effective methods of performing service operations. Some of these service operations require the use of tools specially designed for the purpose. The special tools should be used when and as recommended.

It is important to note that this manual contains various CAUTIONS and NOTICES which should be carefully read in order to minimize the risk of personal injury to service personnel. The possibility exists that improper service methods may damage the equipment. It is also important to understand that these CAUTIONS and NOTICES ARE NOT EXHAUSTIVE. AOC could not possibly know, evaluate and advise the service trade of all conceivable ways in which service might be done or of the possible hazardous consequences of each way. Consequently, AOC has not undertaken any such broad evaluation. Accordingly, a servicer who uses a service procedure or tool which is not recommended by AOC must first satisfy himself thoroughly that neither his safety nor the safe operation of the equipment will be jeopardized by the service method selected.

Hereafter throughout this manual, AOC Company will be referred to as AOC.

WARNING

Use of substitute replacement parts, which do not have the same, specified safety characteristics might create shock, fire, or other hazards.

Under no circumstances should the original design be modified or altered without written permission from AOC. AOC assumes no liability, express or implied, arising out of any unauthorized modification of design. Servicer assumes all liability.

FOR PRODUCTS CONTAINING LASER:

DANGER-Invisible laser radiations when open AVOID DIRECT EXPOSURE TO BEAM.

CAUTION-Use of controls or adjustments or performance of procedures other than those specified herein may result in hazardous radiation exposure.

CAUTION -The use of optical instruments with this product will increase eye hazard.

TO ENSURE THE CONTINUED RELIABILITY OF THIS PRODUCT, USE ONLY ORIGINAL MANUFACTURER'S REPLACEMENT PARTS, WHICH ARE LISTED WITH THEIR PART NUMBERS IN THE PARTS LIST SECTION OF THIS SERVICE MANUAL.

Take care during handling the LCD module with backlight unit

- Must mount the module using mounting holes arranged in four corners.
- Do not press on the panel, edge of the frame strongly or electric shock as this will result in damage to the screen.
- Do not scratch or press on the panel with any sharp objects, such as pencil or pen as this may result in damage to the panel.
- Protect the module from the ESD as it may damage the electronic circuit (C-MOS).
- Make certain that treatment person's body is grounded through wristband.
- Do not leave the module in high temperature and in areas of high humidity for a long time.
- Avoid contact with water as it may a short circuit within the module.
- If the surface of panel becomes dirty, please wipe it off with a soft material. (Cleaning with a dirty or rough cloth may damage the panel.)

1. General Specification

Television System:

NTSC standard

ATSC standard (8-VSB, Clear-QAM)

Channel Coverage:

VHF: 2 through 13

UHF: 14 through 69

Cable TV: Mild band (A - 8 through A - 1, A through I)Super band (J through W)Hyper band (AA through ZZ, AAA, BBB)Ultra band (65 through 94, 100 through 125)

Power Source:

AC power supply: 100V~240 V, 50/60 Hz

Power Consumption

≤ 120 W

1 W in standby mode (power cord plugged in and power OFF)

Audio Power

5 W + 5 W, Internal Speaker

Video/Audio Terminals:

Rear AV x1: S-Video/Video/Audio Input

S-VIDEO INPUT:

Y : 1 V(p-p), 75 ohm, negative sync.

C : 0.286 V(p-p) (burst signal), 75 ohm

VIDEO/AUDIO INPUT:

VIDEO: 1 V(p-p), 75 ohm, negative sync.

AUDIO: 500mv(rms)

Component INPUT:**Rear Component x1:**

Y : 1V(p-p), 75 ohm, including sync.

Pr/Cr: $\pm 0.35V$ (p-p), 75 ohmPb/Cb: $\pm 0.35V$ (p-p), 75 ohm

AUDIO: 500mv(rms)

Supported resolutions:1080i, 720p, 480p, 480i

HDMI Terminals:**HDMI INPUT:** Rear HDMI x1

HDCP compliant

E-EDID compliant

Supported scan rates: 1080i, 720p, 480p, 480i

VGA Terminals:**VGA INPUT:**

Rear VGA (D-SUB 15 Pin) Input x1

E-EDID compliant

Supported scan rates:

640X480 /60Hz/72Hz/75Hz

720X400 /70Hz

800x600 /56Hz/60Hz/72Hz/75Hz

1024X768 /60Hz/70Hz/75Hz

1360X768 /60Hz

Recommended: 1360X768 /60Hz

Audio INPUT: Headphone Mini-jack for stereo
(3.5Ø)**Dimensions:****Include Stand:**

651.9mm(W) x 481.4mm(H) x 219.5mm(L)

Weight:

8.8kg(With Stand)

Wall Mounting:

200x100mm

(Wall mount kit is not included)

Supplied Accessories:

1pcs Power cord

1pcs Remote control

(with two size AAA alkaline batteries)

1pcs User manual

1pcs Setup Guide

2. Operating Instructions

2.1 The Use of Remote Control

POWER

Press to power ON/OFF (standby) the TV.
Press to turn TV ON after the power on status and the LED has changed to the red color and stopped flashing. (Note: the TV is never completely powered off unless it is physically unplugged.)

VIDEO

Press to choose S-Video/ Composite mode.

COMP

Press to choose Component mode.

PC/HDMI

Press repeatedly to choose either VGA or HDMI mode.

TV

Press to choose ATSC/NTSC TV mode.

0 ~ 9 /- number

Press to enter TV channel number to select channel (Press '-' to choose the sub-channel).

SLEEP

Allows you to set a time period after which the TV will enter Standby mode (off/5 min /10 min /15 min /30 min/45 min /60 min/90 min/120 min /180 min /240 min).

FREEZE

Press to freeze the displayed picture.

CH-/ CH +

Press + or - to browse through the TV channels.

MENU

Press to open / exit OSD menu.

Use the "<",">","^","v","ENTER" Keys to adjust the various function items in the menu.

PREV CH

Press to display the previous channel

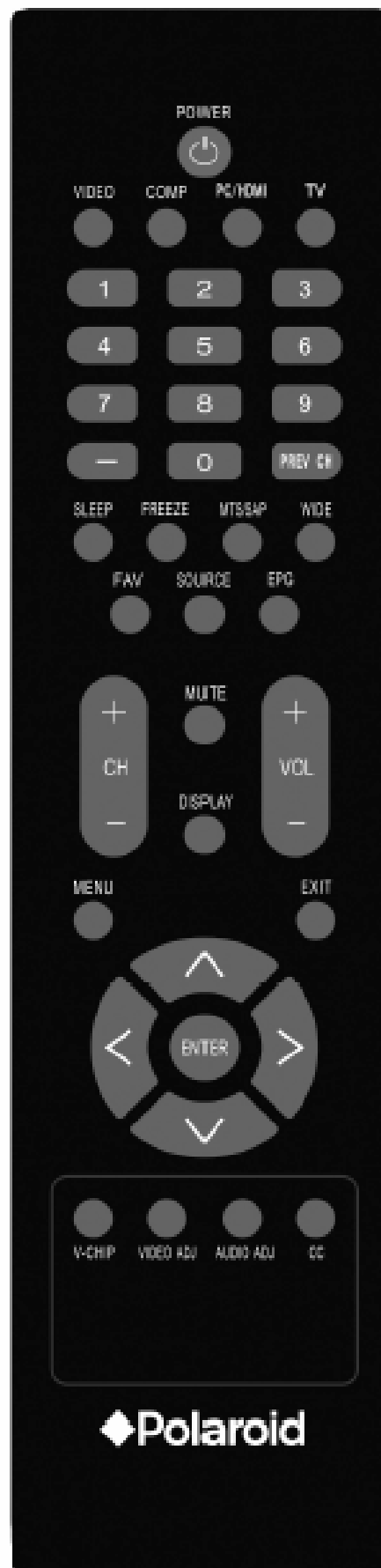

MTS/SAP

Press to activate various audio modes, such as: Stereo, SAP or Mono tone, and languages of DTV.

WIDE

Press to choose the TV's aspect ratio as: Normal, Wide, Zoom or Cinema mode.

SOURCE

Press repeatedly to choose from the various input sources.

EPG

This function is not available.

MUTE

Switch the sound ON/OFF

DISPLAY

Press to show the information about the input source,TV channel,display resolution and current time.

VOL- /VOL+

Press + or - to adjust the volume.

Exit

Press to exit menu or OSD.

V-CHIP

Press to lock / unlock Parental Control temporarily. (After setting the restricted table of MPAA or TV Rating.)

VIDEO ADJ

Press to choose the Brightness or Contrast adjustment.

AUDIO ADJ

Press to choose Bass or Treble.

CC

Press repeatedly to change the closed caption type as CC ON/ CC OFF/CC ON WHEN MUTE.

FAVORITE

Press to toggle the Favorite/ Normal channel mode.

2.2 To Use the Menu

- 1 Press the **MENU** button to display the main menu.
- 2 Press the ∇ or \triangle button repeatedly to select a menu item.
- 3 Press the $<$ or $>$ buttons to enter a sub-menu.
- 4 Press the **ENTER** or $>$ button to enter/display the function.
- 5 Press **MENU** or **EXIT** to exit the menu.

Press the Menu button to enter the main OSD (On Screen Display). Adjust the items including **Setup** menu, **Video** menu, **Audio** menu and **Feature** menu. However, some function items of the menus are only available with specific inputs/source.

SETUP MENU

The Setup menu in TV mode shows as below. In others source modes, the **Setup** menu only shows **Menu Language** and **Aspect Ratio** items.

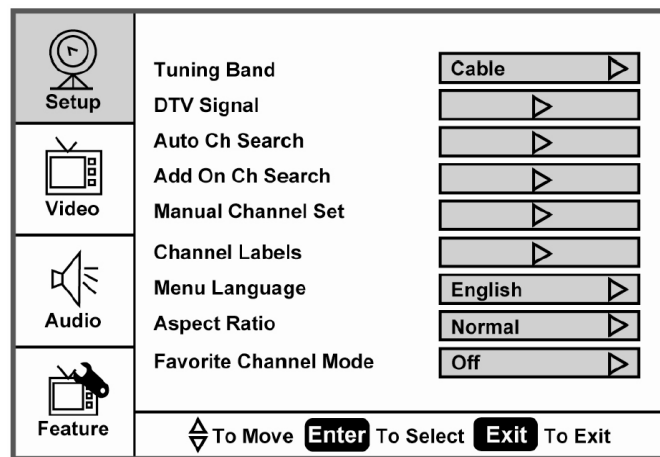

1. **Tuning Band:** Select TV source signal from the Air (antenna) or Cable (CATV).
2. **DTV Signal:** Show the intensity of the received DTV signal.

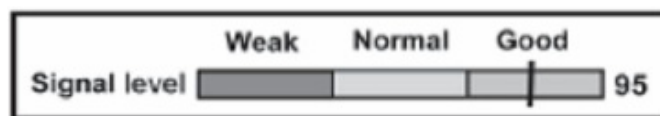

3. **Auto Ch Search:** Automatically scan all NTSC / ATSC TV channels and then store in the channel table. In channel scan process, the OSD can display the number of channels which had been found.
4. **Add on Ch search:** Add channels which are new found.
5. **Manual Channel Set:** Show the channel setup table. User can choose to display the ATSC or NTSC TV channels and then edit the channel (Viewable or Not Viewable by pressing Enter button). User won't be able to view the channel that has been set to Not Viewable when toggling through channels. However, the channels are still accessible when user enters the channel number.
6. **Channel Labels:** Show the NTSC / ATSC TV channel label menu for user modifying channel labels specifically.
7. **Menu Language:** Select the menu display language. (English / Espanol / Francais)
8. **Aspect Ratio:** Select the display aspect ratio. (Normal/Zoom/Wide/Cinema)
9. **Favorite Channel Mode:** When favorite channel mode is on, user can edit favorite channel table in favorite channel set option.

VIDEO MENU

The Video menu in most source modes shows as below. It provides several video adjustment items for user fine tuning the video display. Only in VGA source modes, the Video menu simply provides **Contrast**, **Brightness**, **Back light** and **Settings (Preset)** items.

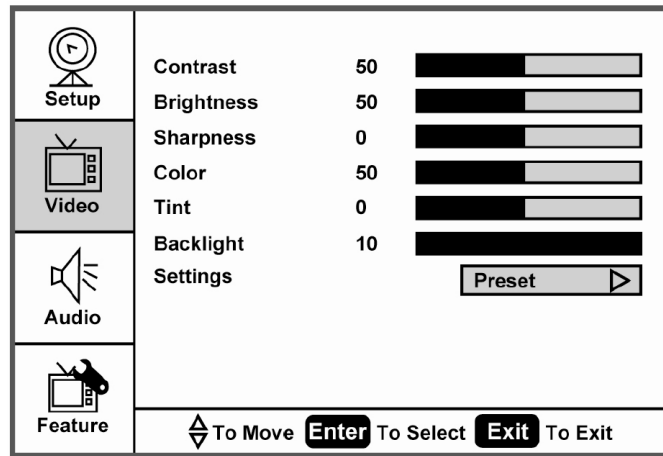

1. **Contrast:** Video contrast adjustment, the tuning range is 0 ~ 100.
2. **Brightness:** Video brightness adjustment, the tuning range is 0 ~ 100.
3. **Sharpness:** Video sharpness adjustment, the tuning range is -50 ~ 50.
4. **Color:** Video color chroma adjustment, the tuning range is 0 ~ 100.
5. **Tint:** Video tint adjustment, the tuning range is R50 ~ G50.
6. **Backlight:** Backlight strength adjustment, the tuning range is 0 ~ 10.
7. **Settings:** Restore the default video settings.

AUDIO MENU

The Audio menu in TV mode shows as below. It provides audio adjustment for user to modify the audio setting. Audio language setting is only available with ATSC TV source, the option is disable under other source modes.

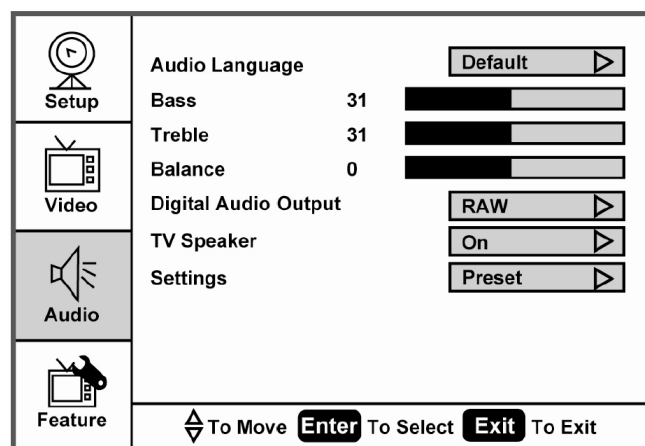

1. **Audio Language:** Change the audio language setting on ATSC TV programs .The number of the supported audio languages depends on the ATSC TV programs.
2. **Bass:** Bass tone adjustment, the tuning range is 0 ~ 63.
3. **Treble:** Treble tone adjustment, the tuning range is 0 ~ 63.
4. **Balance:** Audio balance adjustment, the tuning range is L31 ~ R31.
5. **Digital Audio Output:** Digital audio output format selection, user can choose RAW (default) or PCM format or off.

6. **TV Speaker:** Choose to turn on / off the TV internal speaker. The digital audio output signals \ earphone output signals will not be turn-off even though the TV speaker is off. The default setting is on.

7. **Settings:** Restore the default audio settings.

FEATURE MENU

The Feature menu in TV mode shows as below. It provides certain optional control functions such as time set, sleep timer, advanced video menu, Password Set, parental control (V-chip) and Digital closed caption setting. This menu gives users the most flexibilities to satisfy their generally demands. According to the various requirements in different source modes, certain features should be hidden (disable) on the menu. The details footnotes will be described clearly below.

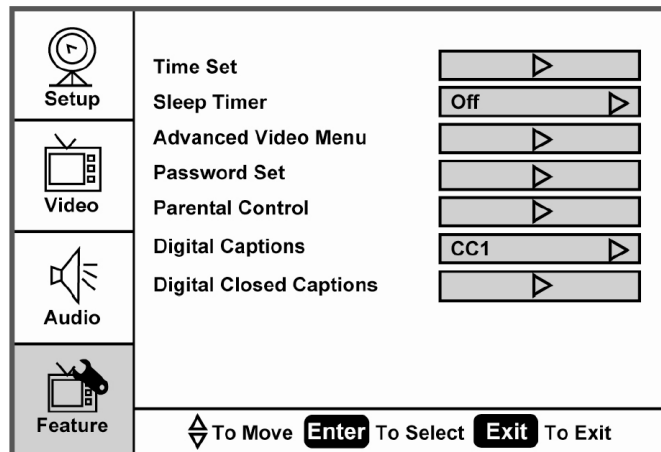

1. **Time Set:** Set the current time. This sub-menu includes Time Set Mode, Time **Zone** and **Time** items. 【Time Set Mode】 user can choose Auto or Manual, 【Time Zone】 item provides user to set current time zone, such as: Pacific, Alaska, Hawaii, Eastern, Central and Mountain. 【Time】 item provides user to set the time clock.

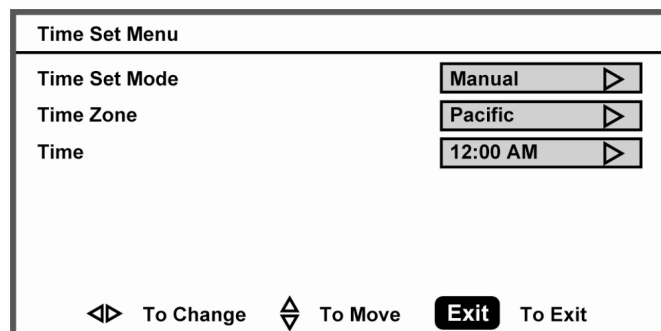

2. **Sleep Timer:** Enable or disable the TV standby timer. User can set the TV standby timer as off / 5 min / 10 min / 15 min/ 30 min / 45 min / 60 min/ 90 min / 120 min / 180min/ 240min.

3. **Advanced Video Menu:** Provide the Noise Reduction \Color Temperature and 3D Y/C. Dynamic Contrast options for enhancing video quality.

【Noise Reduction】 gives four NR effect degrees, such as: Low, Mid, High and Off. The default setting is Mid.

【Colour Temp】 gives three color temperature modes as: Normal \ Warm and Cool.

【3D Y/C】 provides On / Off switches. The default setting is On.

【 Dynamic Contrast】 user can choose On or Off.

【Setting】 restores the default advanced video option settings.

4. **Password Set:** Change the 4-numeral parental control password. Three steps are required for changing the password: Enter Old Password -> Enter New Password -> Confirm New Password. Note: This item is only available in TV, Composite and S-Video source modes. The default password is 『0 0 0 0』.

Enter Old Password

Enter New Password

Confirm New Password

5. **Parental Control:** provide the parental Control (V-chip) function setting. Before entering the Parental Control sub-menu, user has to key in the password first. Then enter the Parental Lock item, User can modify the restricted table about MPAA or TV Rating respectively. While exiting the sub-menu, the parental control function is working. The inhibitive channels or source signals can be un-lock through pressing the V-CHIP key on the remote control and then key in the correct password. Note: This feature is only available in TV, Composite and S-Video source modes. (The default password is: 0 0 0 0.)

Enter Password

Parental Control Menu

USA Parental Locks ▶

Canadian Parental Locks ▶

⬅ To Move **Enter** To Select **Exit** To Exit

USA Parental Locks

MPAA		TV RATING						
		ALL	FV	L	S	V	D	
NONE	<input type="checkbox"/>	NONE	<input type="checkbox"/>					
G	<input type="checkbox"/>	TV-Y	<input type="checkbox"/>					
PG	<input type="checkbox"/>	TV-Y7	<input type="checkbox"/>	<input type="checkbox"/>				
PG-13	<input type="checkbox"/>	TV-G	<input type="checkbox"/>					
R	<input type="checkbox"/>	TV-PG	<input type="checkbox"/>	<input type="checkbox"/>	<input type="checkbox"/>	<input type="checkbox"/>	<input type="checkbox"/>	
NC-17	<input type="checkbox"/>	TV-14	<input type="checkbox"/>	<input type="checkbox"/>	<input type="checkbox"/>	<input type="checkbox"/>	<input type="checkbox"/>	
X	<input type="checkbox"/>	TV-MA	<input type="checkbox"/>	<input type="checkbox"/>	<input type="checkbox"/>	<input type="checkbox"/>		

⬅ To Move **Enter** To Select **Exit** To Exit

6. **Digital Captions:** Select the close caption options (Service 1-6, Text 1-4 and CC 1-4) in digital TV mode. When select service 1 to service 6, you can modulate parameters in the Digital Close Caption.

7. **Digital Close Caption:** Provide numerous options for setting the digital close caption style. In the sub-menu **【Style】** item can be set as Automatic or Custom mode. If Custom mode is selected, user can modify the detail styles described below. The setting result will be shown immediately on the bottom side of the sub-menu OSD.

Note: This feature is only available in Digital TV (ATSC) mode.

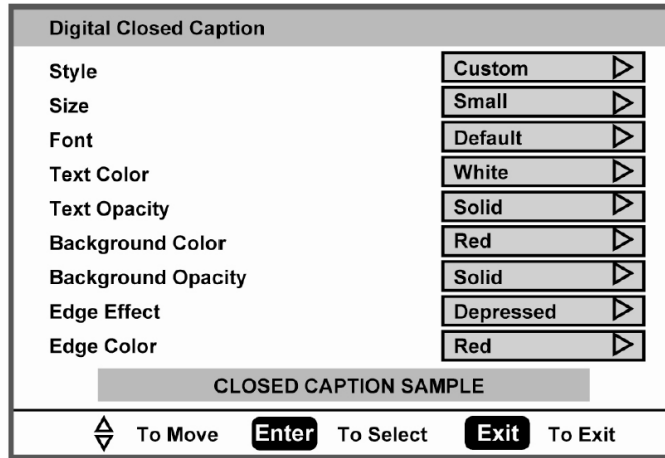

【Size】 : Digital close caption font size, which can be set as Small 、 Normal or Large.

【Font】 : Digital close caption font style, which can be chosen as Default or Font 1 ~ 7.

【Text Color】 : Giving Red / Green / Blue/ Yellow / Magenta / Cyan / Black / White Colors.

【Text Opacity】 : Giving Transparent / Translucent / Solid / Flashing modes.

【Background Color】 : Giving Red / Green / Blue / Yellow / Magenta / Cyan / Black / White Colors.

【Background Opacity】 : Giving Transparent / Translucent / Solid /Flashing modes.

【Edge Effect】 : The text edge effects, which gives None / Raised /Depressed / Uniform / Left Shadow / Right Shadow modes.

【Edge Color】 : The colors of text edge effects, which provides Red /Green / Blue / Yellow / Magenta / Cyan / Black / White Colors.

8. **Component Set:** This option only shows and is available in component mode, which provides fine tuning component display, such as: **【H-Position】** **【V-Position】**, **【Clock】**and**【Phase】**(Auto Adjust function is not supported under Component mode). All these items are giving the tuning range from 0 to 100. **【Setting】** item provides the default component setting values restoring.

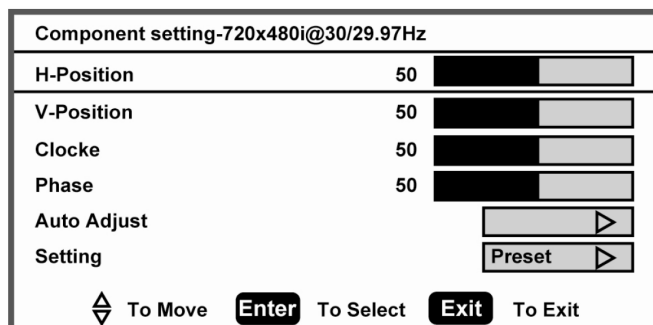

9. **VGA Set:** This option only shows and is available in VGA mode, which provides several items for the VGA display fine tuning, such as : **【H Position】** 、 **【V-Position】** 、 **【Clock】**, **【Phase】**, and **【Auto Adjust】** .All these items giving the tuning range from 0 to 100. **【Setting】** item provides the default VGA setting values restoring.

VGA setting - 1360x768x60		
H-Position	50	
V-Position	50	
Clocke	50	
Phase	50	
Auto adjust		
Setting		

To Move **Enter** To Select **Exit** To Exit

2.3 How to Connect

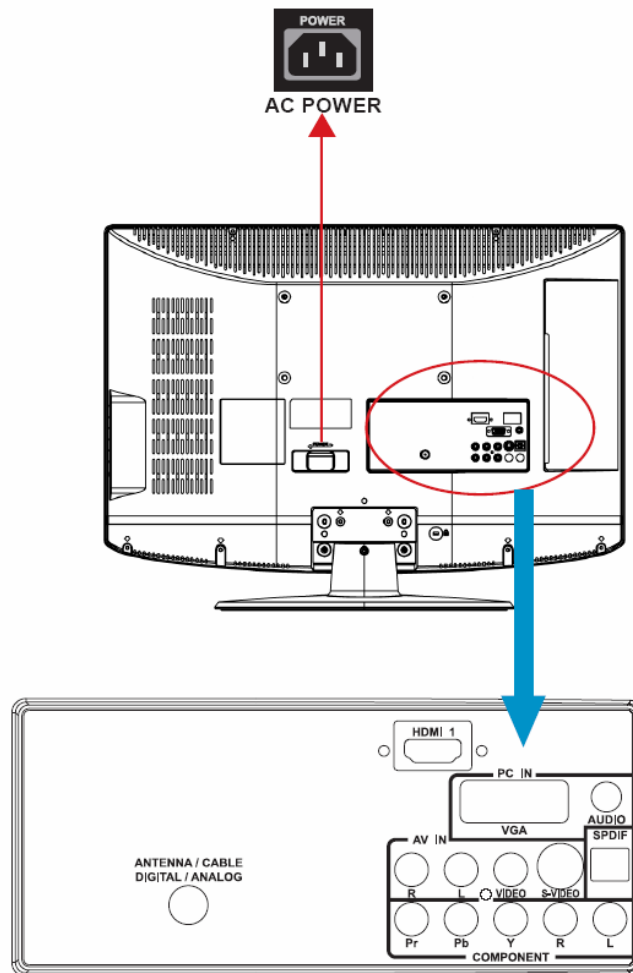

1. HDMI – Connect the primary source for digital video such as a DVD multimedia player or set top box through this all digital connector.
2. PC IN – Connect the video and audio cables from a computer here.
3. AV/S-VIDEO IN – Connect the primary source for composite video devices, such as a VCR or video game. Use the white and red connectors to connect the external audio from the same source. The signal being carried by the S-Video cable and connector, if connected, will take priority over the Video RCA connector (yellow connector).
4. COMPONENT (YPb/CbPr/Cr with Audio L/R) – Connect the primary source for component video devices such as a DVD Player or set top box here. From left to right, use red for Pr, blue for Pb, green for Y, red for right audio (R) and white for left audio (L) inputs.
5. DTV – Connect to an antenna or digital cable (out-of-the-wall, not from Cable Box) for Digital TV.*
6. SPDIF (Optical Digital Audio Out) - When a digital audio signal is associated with the input selected for viewing, the digital audio will be available on this SPDIF connection to your home theater system.

Once your equipment is connected, use the following procedure to view the input signal:
 Press the source button on the remote control to select the relevant source to view. (ex: Press VIDEO button to select "Composite Rear" if you have connected a video recorder to Composite Rear socket.)

2.4 Front Panel Control Knobs

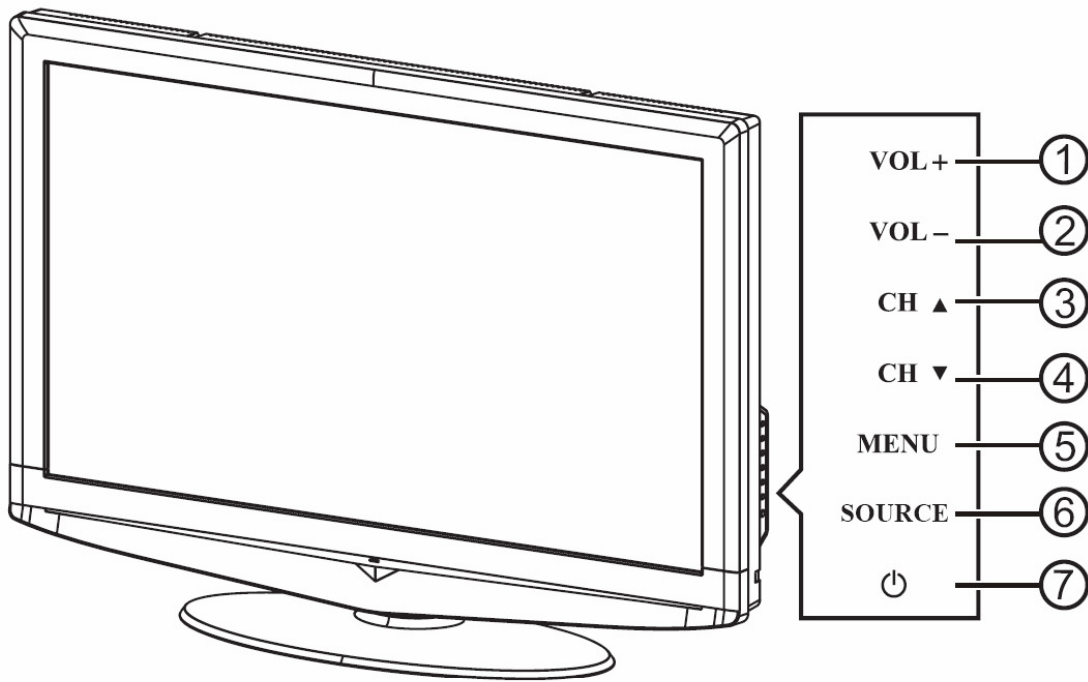

1.	VOL +	VOL +: Press to increase the volume level.
2.	VOL -	VOL - : Press to decrease the volume level.
3.	CH ▲	CH +: Press to select the next higher channel
4.	CH ▼	CH - : Press to select the next lower channel
5.	MENU	Menu key: Press to open or exit the On-Screen Display (OSD) menu.
6.	SOURCE	Source key: Press to select the input source.
7.	⏻	Power key: Press to turn on / off (standby) the TV set. (When the TV is going into Standby mode, the LED will blink Red. In the standby mode, it is solid Red.

3. Input/Output Specification

3.1 RGB Signal input



15 - Pin Color Display Signal Cable

Pin No.	Description	Pin No.	Description
1	Red Video	9	Mandatory +5V Supply for PC Bypass
2	Green Video	10	Sync Ground
3	Blue Video	11	SDA(Remote Control)
4	SCL(Remote Control)	12	Bi-directional Data (SDA) for PC Bypass
5	Ground	13	H-Sync.
6	Red Video Ground	14	V-Sync.
7	Green Video Ground	15	Data Clock (SCL) for PC Bypass
8	Blue Video Ground		

3.2 HDMI Digital connector pin assignments

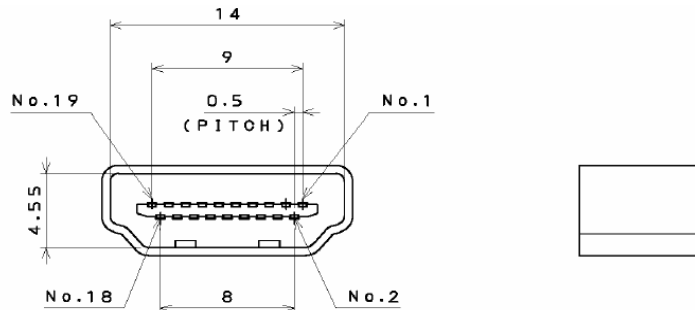

Pin No.	Description	Pin No.	Description
1	TMDS Data2+	2	TMDS Data2 Shield
3	TMDS Data2-	4	TMDS Data1+
5	TMDS Data1 Shield	6	TMDS Data1-
7	TMDS Data0+	8	TMDS Data0 Shield
9	TMDS Data0-	10	TMDS Clock+
11	TMDS Clock Shield	12	TMDS Clock-
13	CEC	14	NC
15	SCL	16	SDA
17	DDC/CEC Ground	18	+5V Power
19	Hot Plug Detect		

3.3 AV/S-Video/Component Video Inputs

AV Signal Performance

Video / S-Video / Component Video Input

All tests must be performed under "video standard testing conditions" unless otherwise specified

Video1

(Composite Video input)

System	NTSC
Amplitude	1.0 V(p-p), negative sync.
Impedance	75 ohm terminated

Video2 (Y / C input)

(S-Video input)

System	NTSC
Y signal amplitude	1.0Vpp (including sync)
C signal amplitude	0.286Vpp
Impedance	75 ohm terminated

Video3

Component (Y, Pb/Cb, Pr/Cr input)

System	1080i, 480p, 720p, 480i
Y signal amplitude	1.0Vpp (including sync)
Cr, (R-Y) / Cb, (B-Y)	± 0.35 Vpp, 75 ohm
Signal amplitude	75 ohm terminated
Impedance	
Y = 0.299R + 0.587G + 0.114B	
(R-Y) = 0.701R + 0.587G + 0.114B	
(B-Y) = 0.299R + 0.587G + 0.886B	

3.4 Compatible Mode Table

VESA MODES							
Mode	Resolution	Total	Horizontal		Vertical		Nominal Pixel Clock (MHz)
			Nominal Frequency (KHz)	Sync Polarity	Nominal Freq. (Hz)	Sync Polarity	
VGA	640x480@60Hz	800 x 525	31.469	N	59.940	N	25.175
	640x480@72Hz	832 x 520	37.861	N	72.809	N	31.500
	640x480@75Hz	840 x 500	37.5	N	75	N	31.500
SVGA	800x600@56Hz	1024 x 625	35.156	P	56.25	P	36.000
	800x600@60Hz	1056 x 628	37.879	P	60.317	P	40.000
	800x600@72Hz	1040 x 666	48.097	P	72.188	P	40.000
	800x600@75Hz	1056 x 625	46.875	P	75	P	49.5
XGA	1024x768@60Hz	1344x806	48.363	N	60.004	N	65.000
	1024x768@70Hz	1328x806	56.476	N	70.069	N	75.000
	1024x768@75Hz	1312x800	60.023	P	75.029	P	78.750
WXGA	1360x768@60Hz	1792x795	47.712	P	60.015	P	85.5

4. Mechanical Instructions

1. Remove the 4 screws to remove the base.

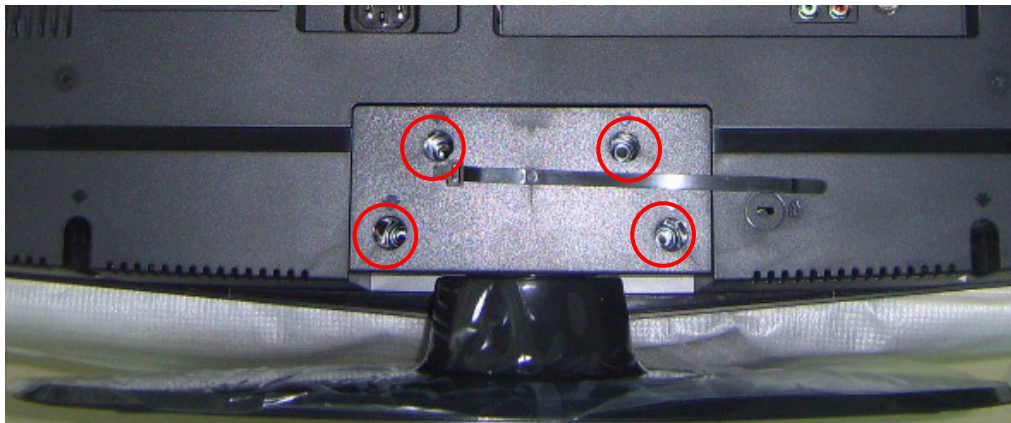

2. Remove 9 screws to remove the rear cover.

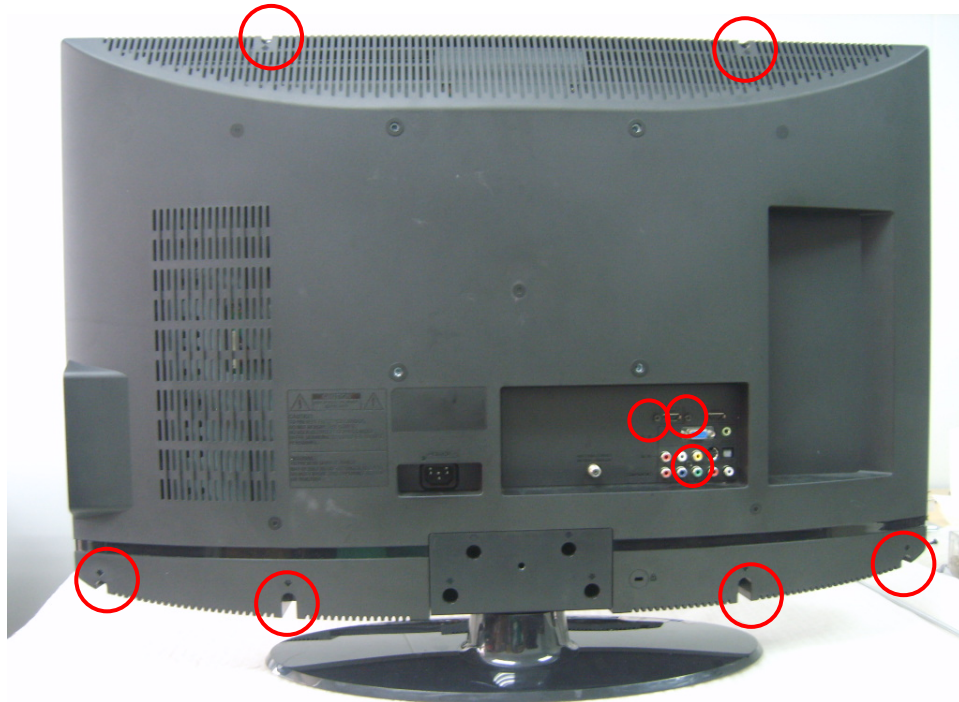

3. Remove the speakers.

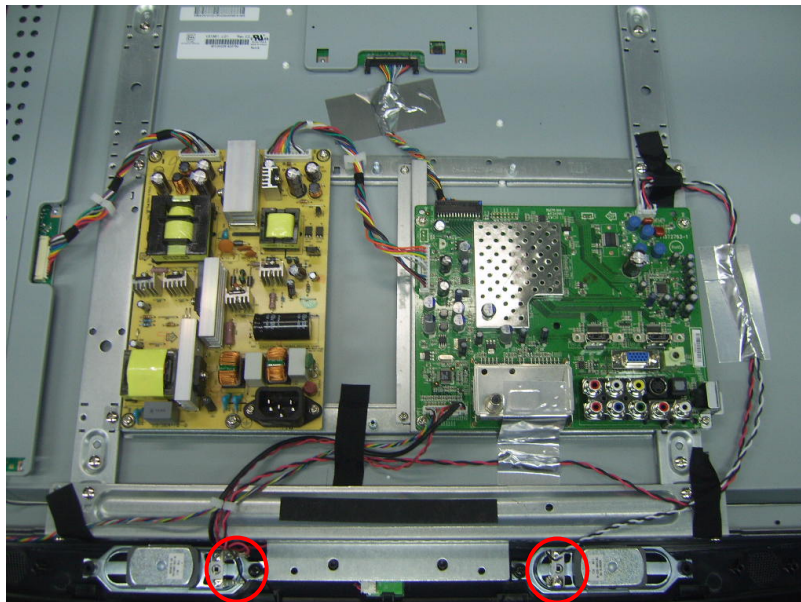

4. Remove the main board, power board

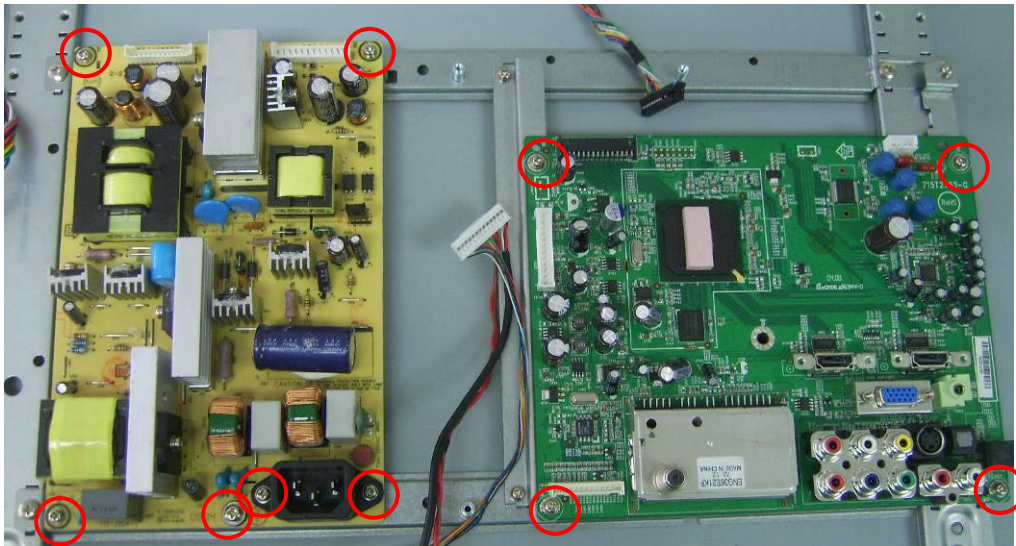

5. Remove the bkt-PCB-hplder.

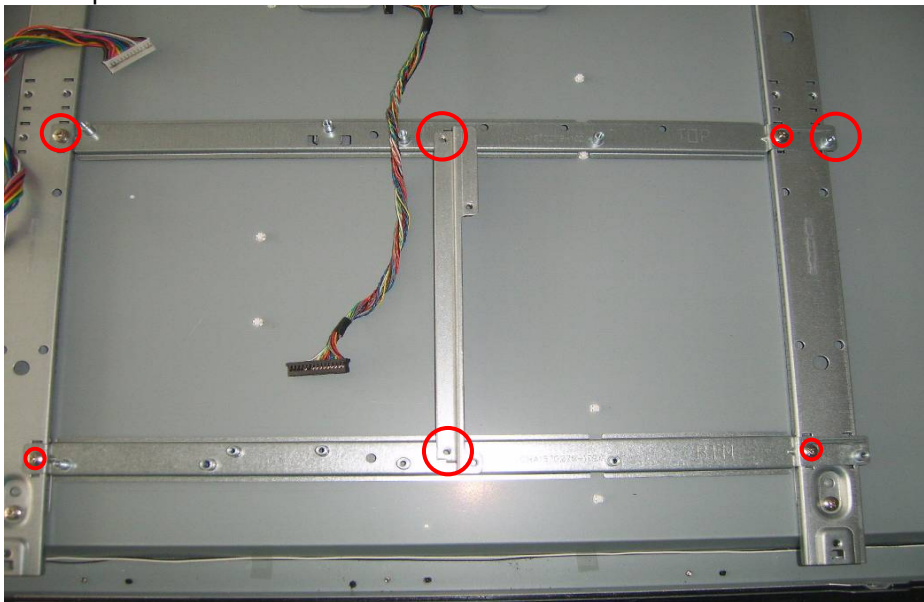

6. Release the key board and IR board.

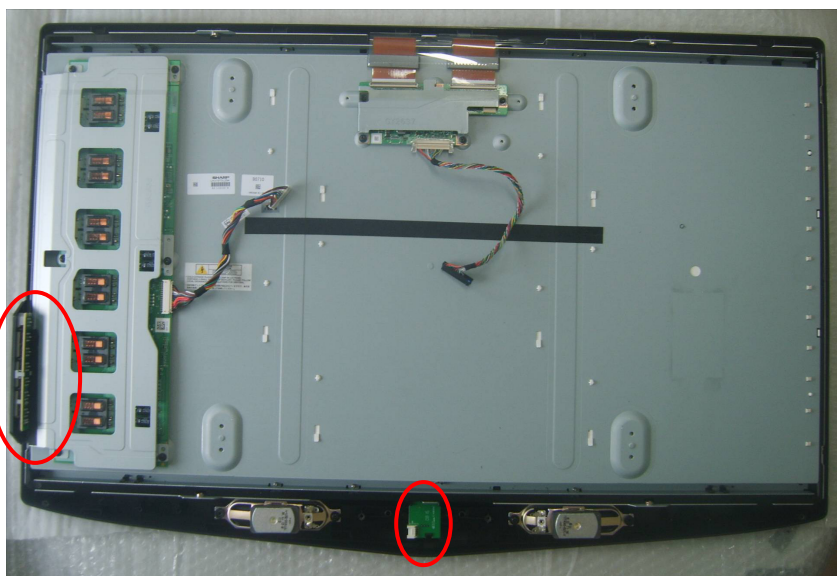

7. Remove the bkt-panel-support.

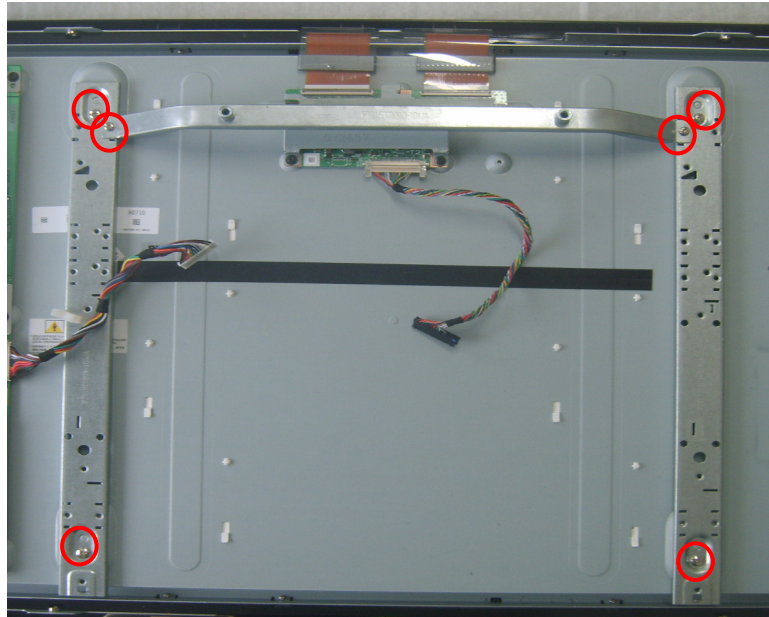

8. Remove the bezel.



9. Remove the 4 screws to release the panel.



5. Repair Flow Chart

1. No Power (No LED indicator)

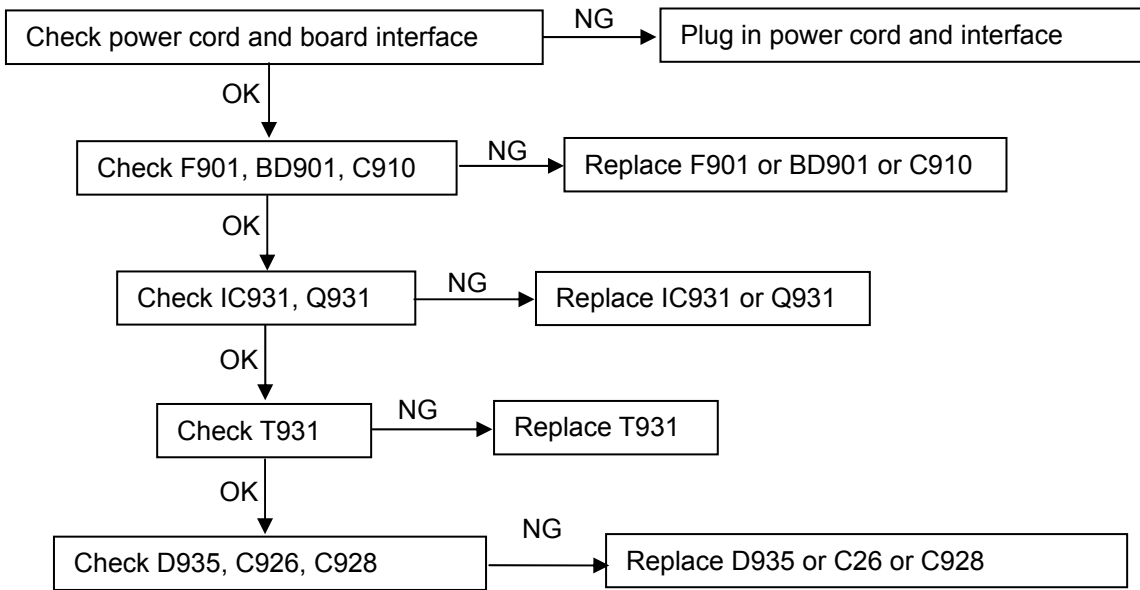

2. Can not start (LED indicator yellow)

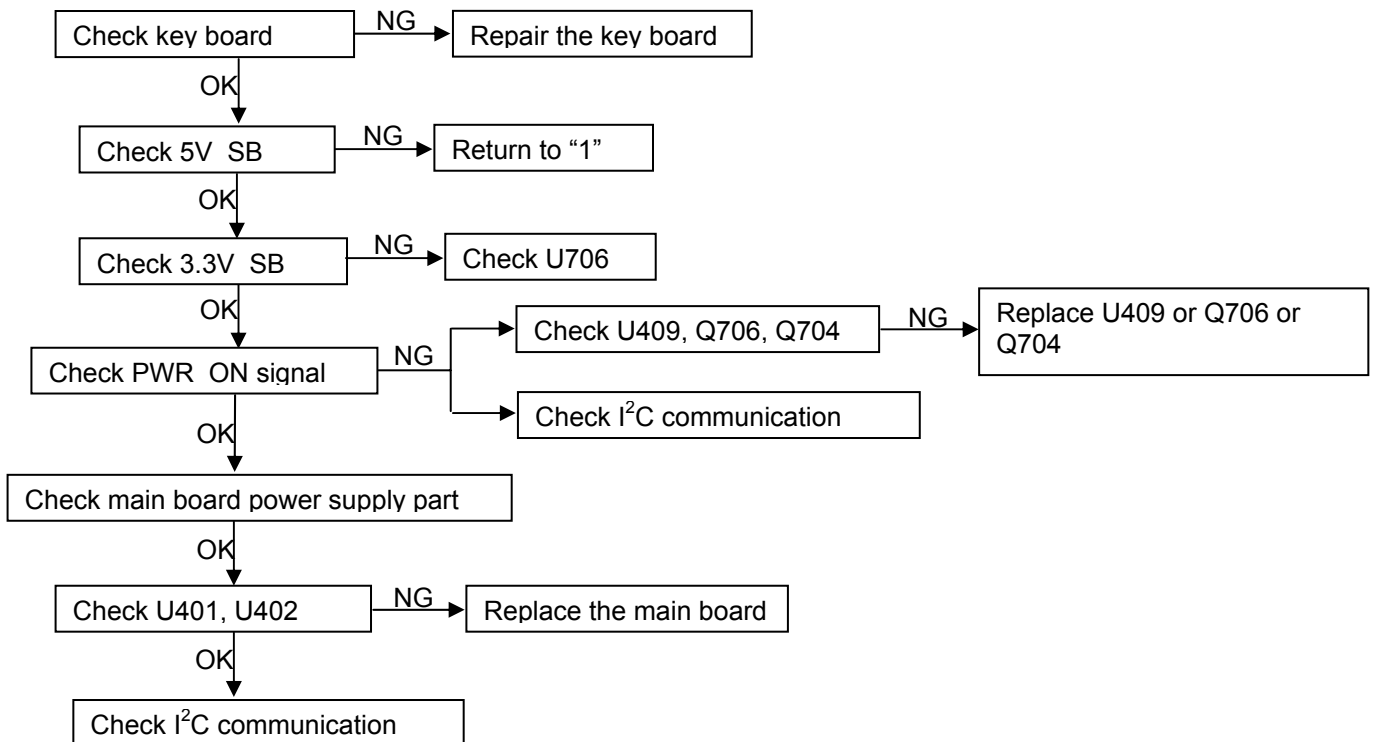

3. No display (LED indicator green)

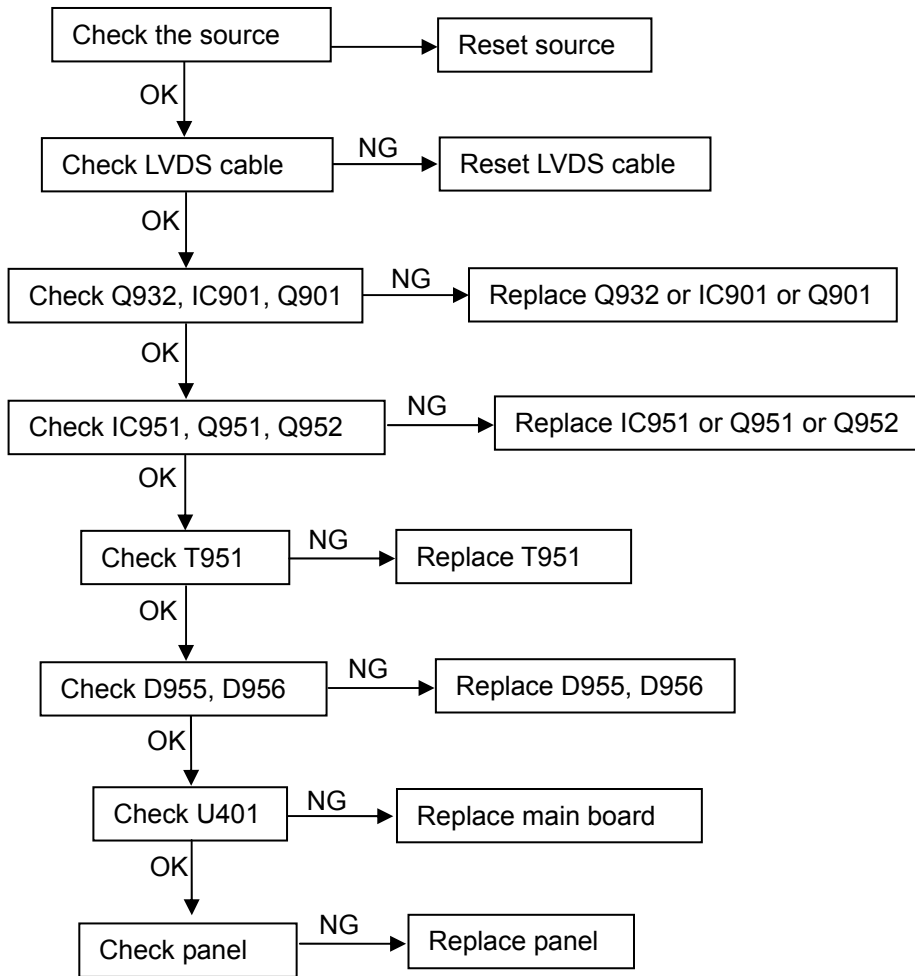

4. Abnormal display

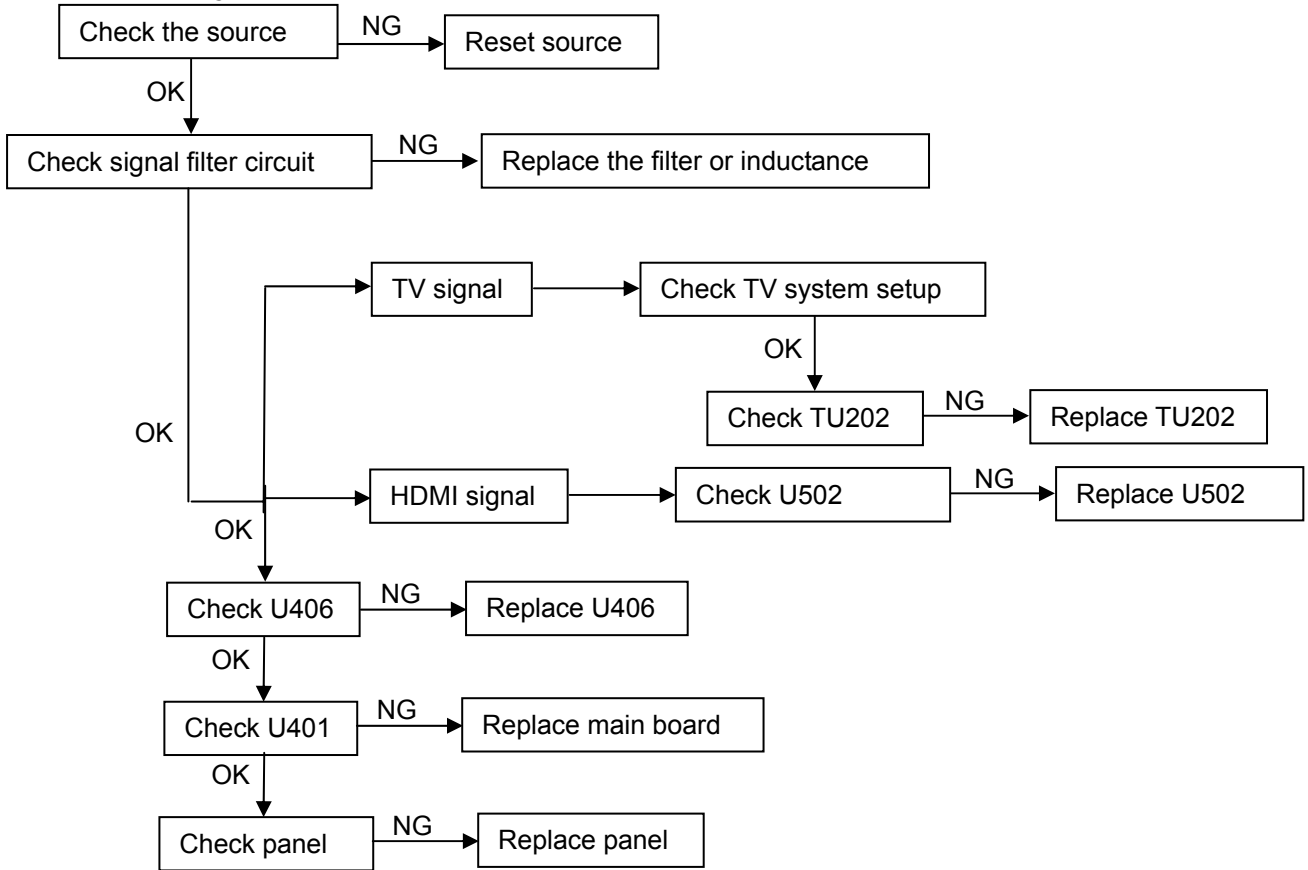

5. No sound

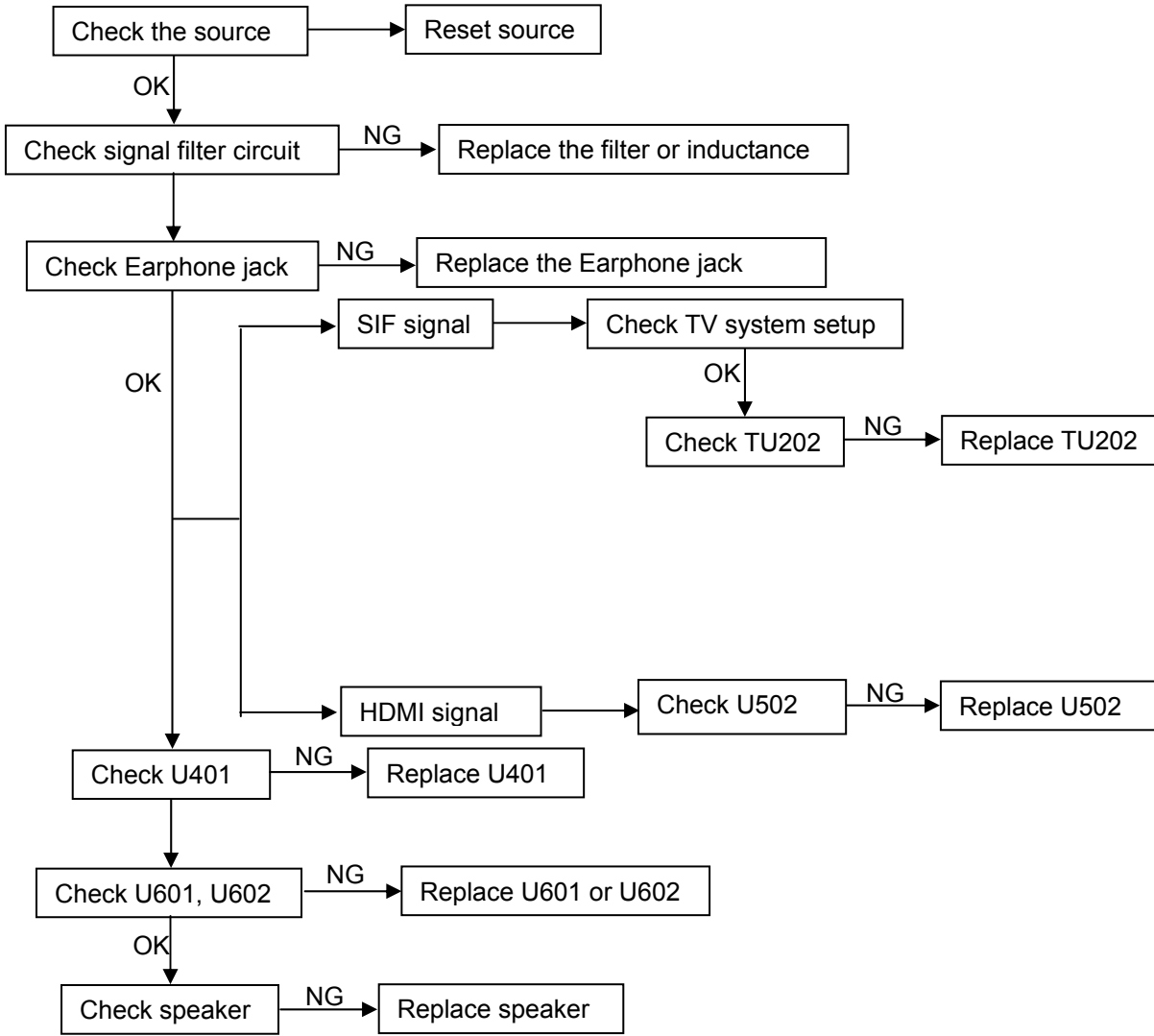

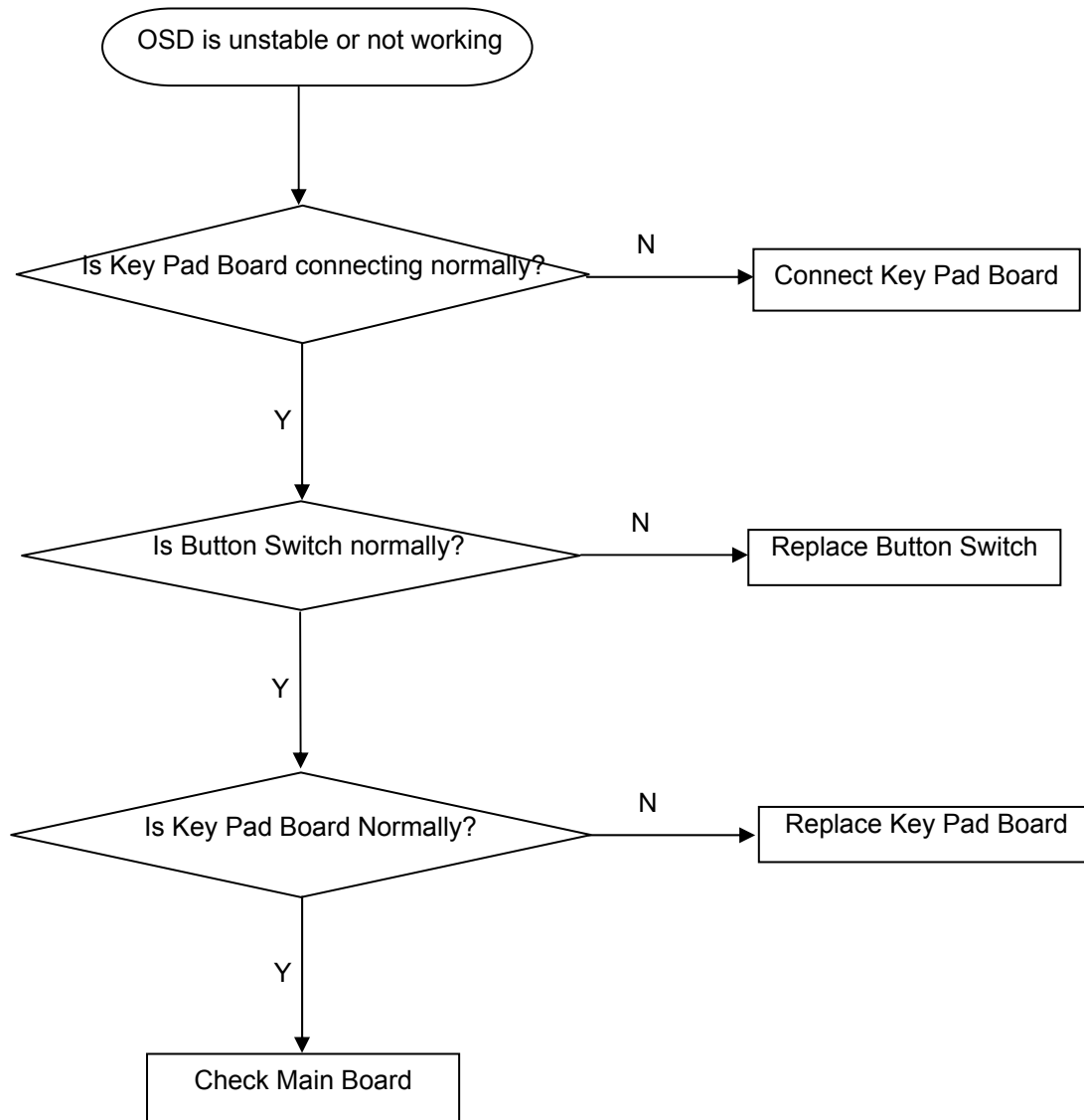

6. PCB Layout

6.1 Main Board

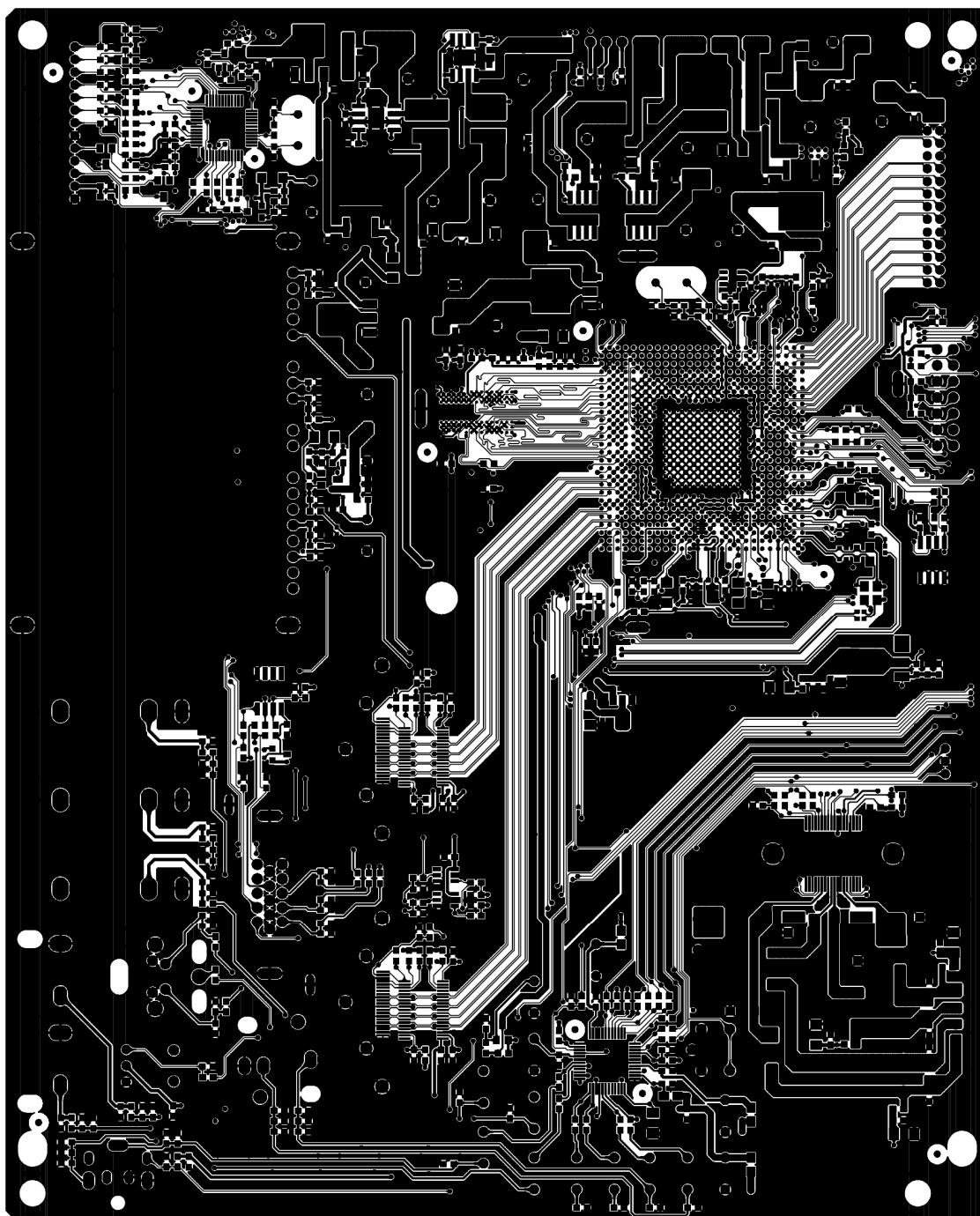

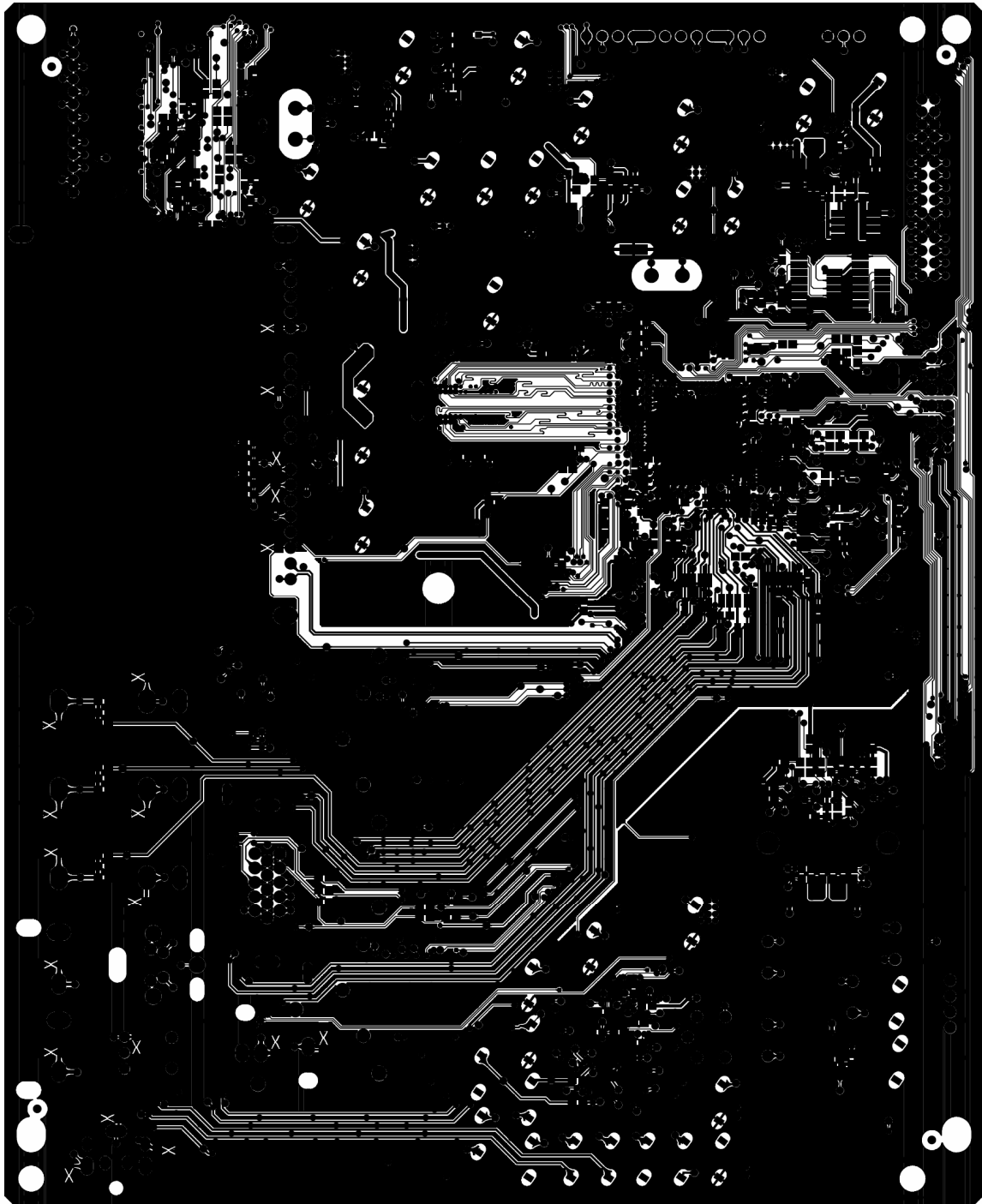

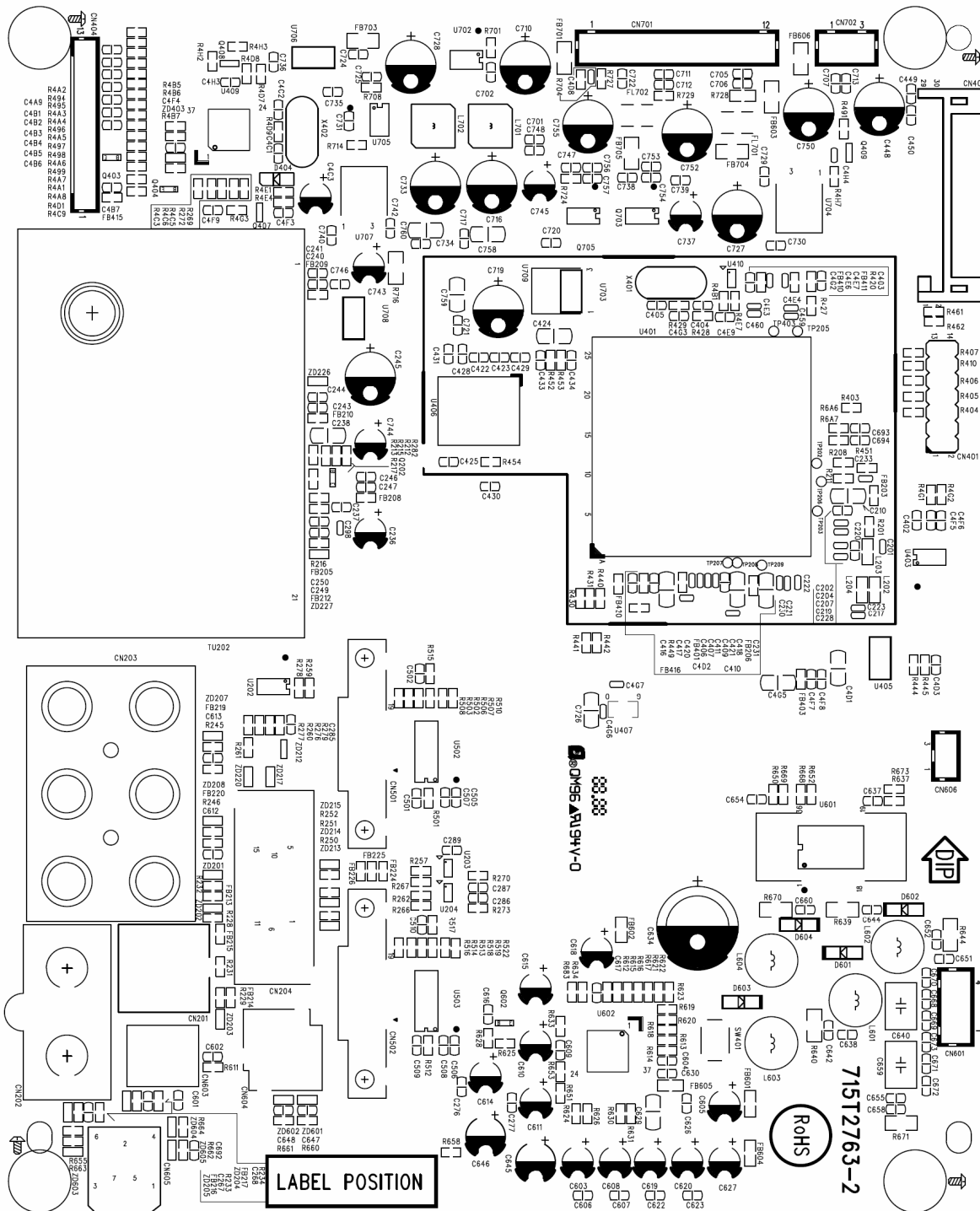

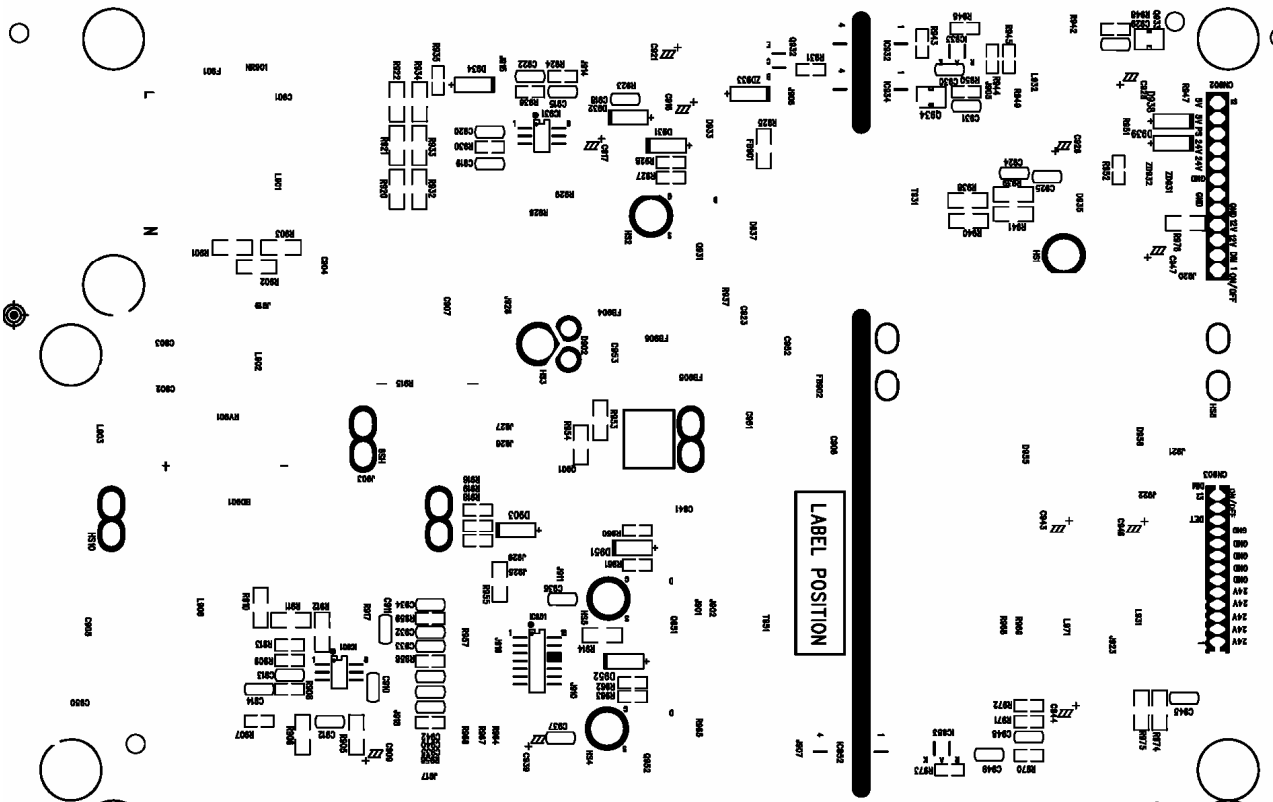
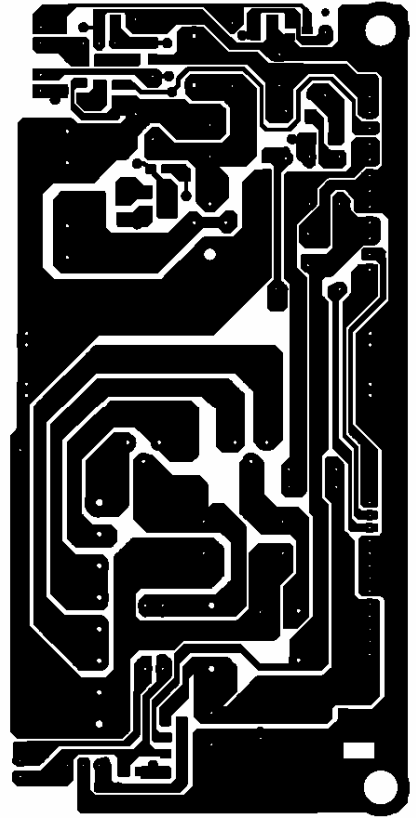
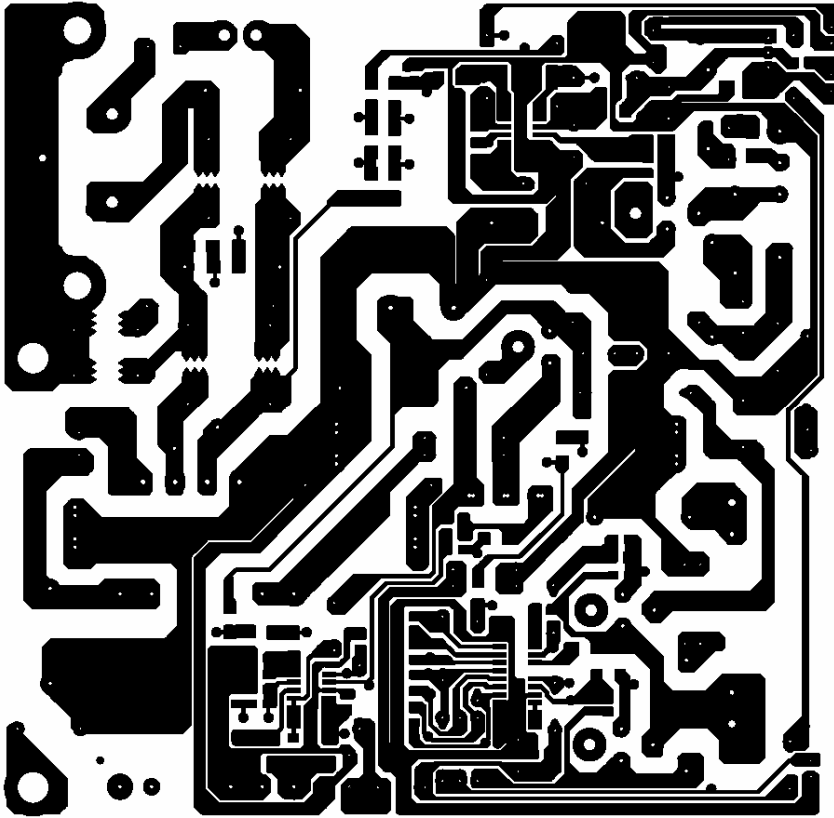

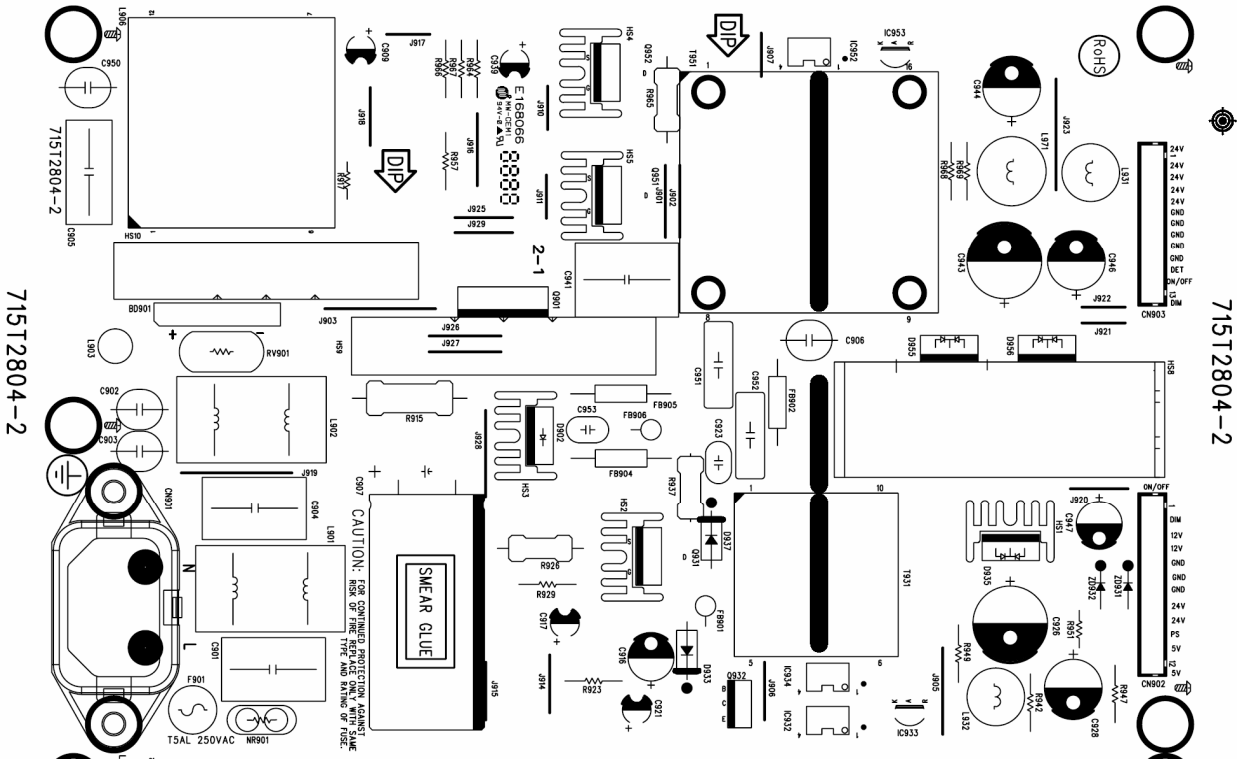

6.3 Key Board

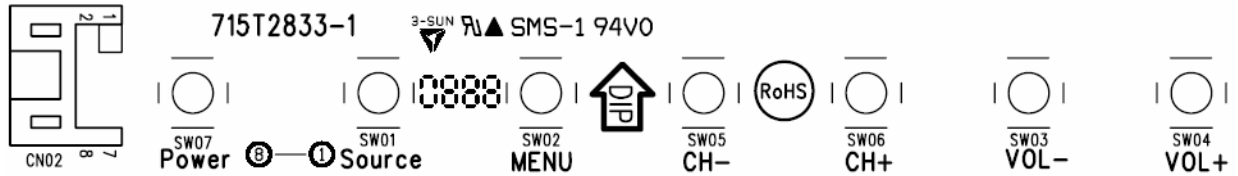

6.4 IR Board

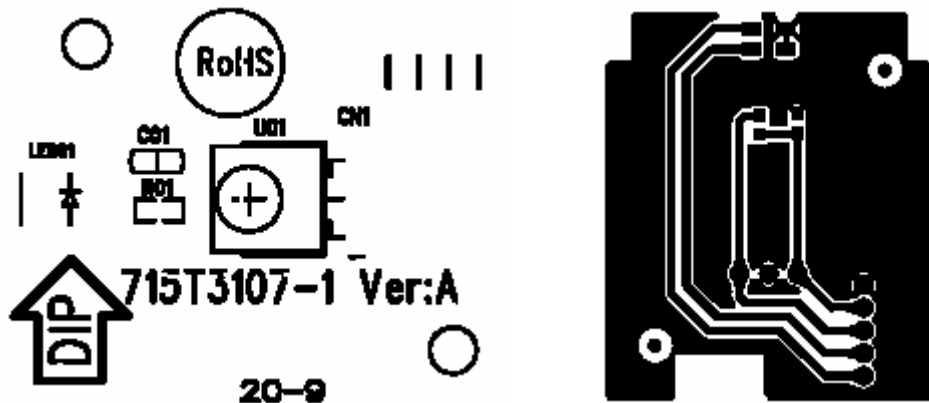

7. Adjustment

It's no need to adjust the white balance for this model .

Enter into the factory mode:

Turn on the TV, press MENU key with remote control, then press number key 1 → 9 → 9 → 9. It will achieve the factory mode.

8. Block Diagram

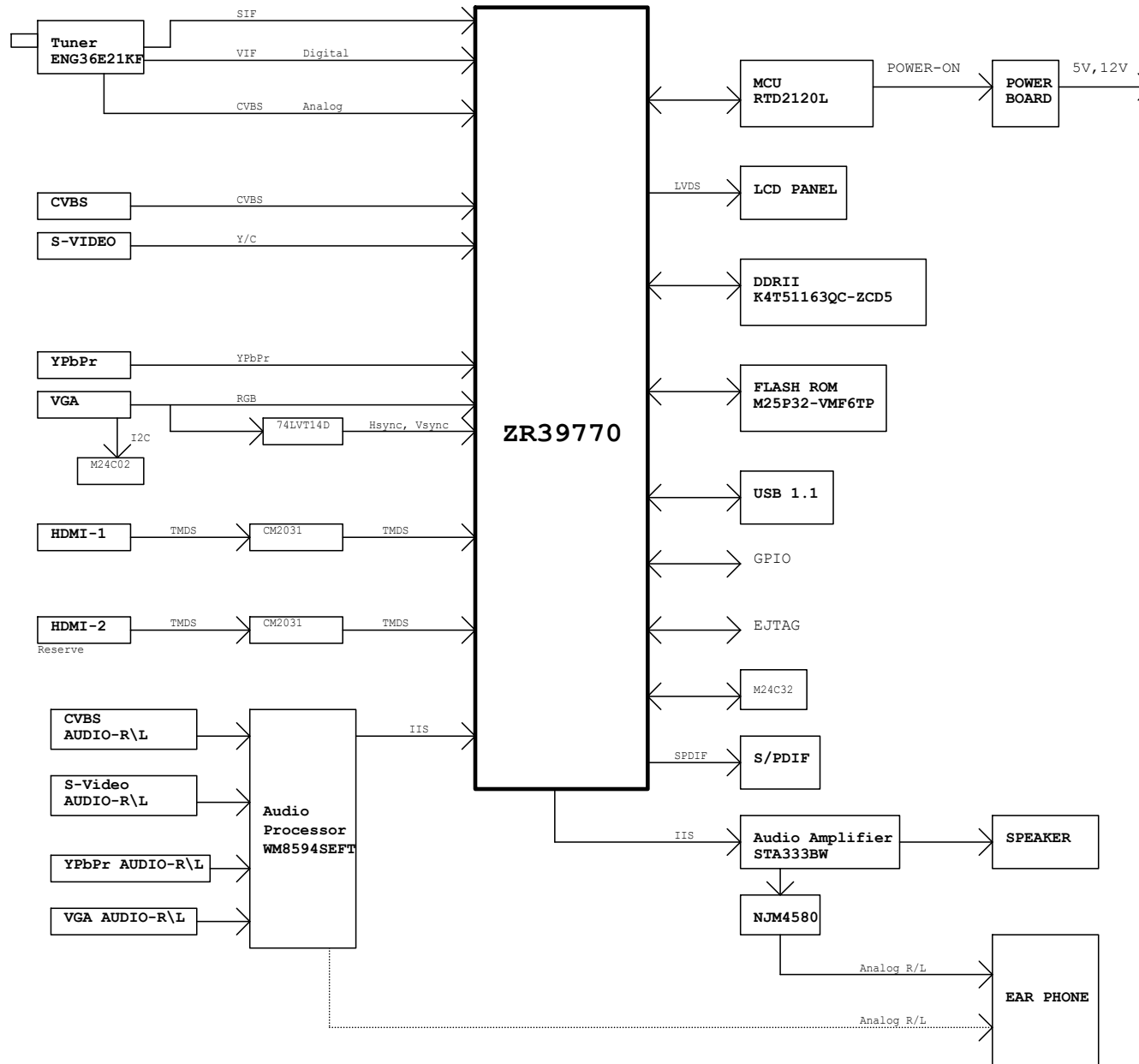

9. Schematic Diagram

9.1 Main Board

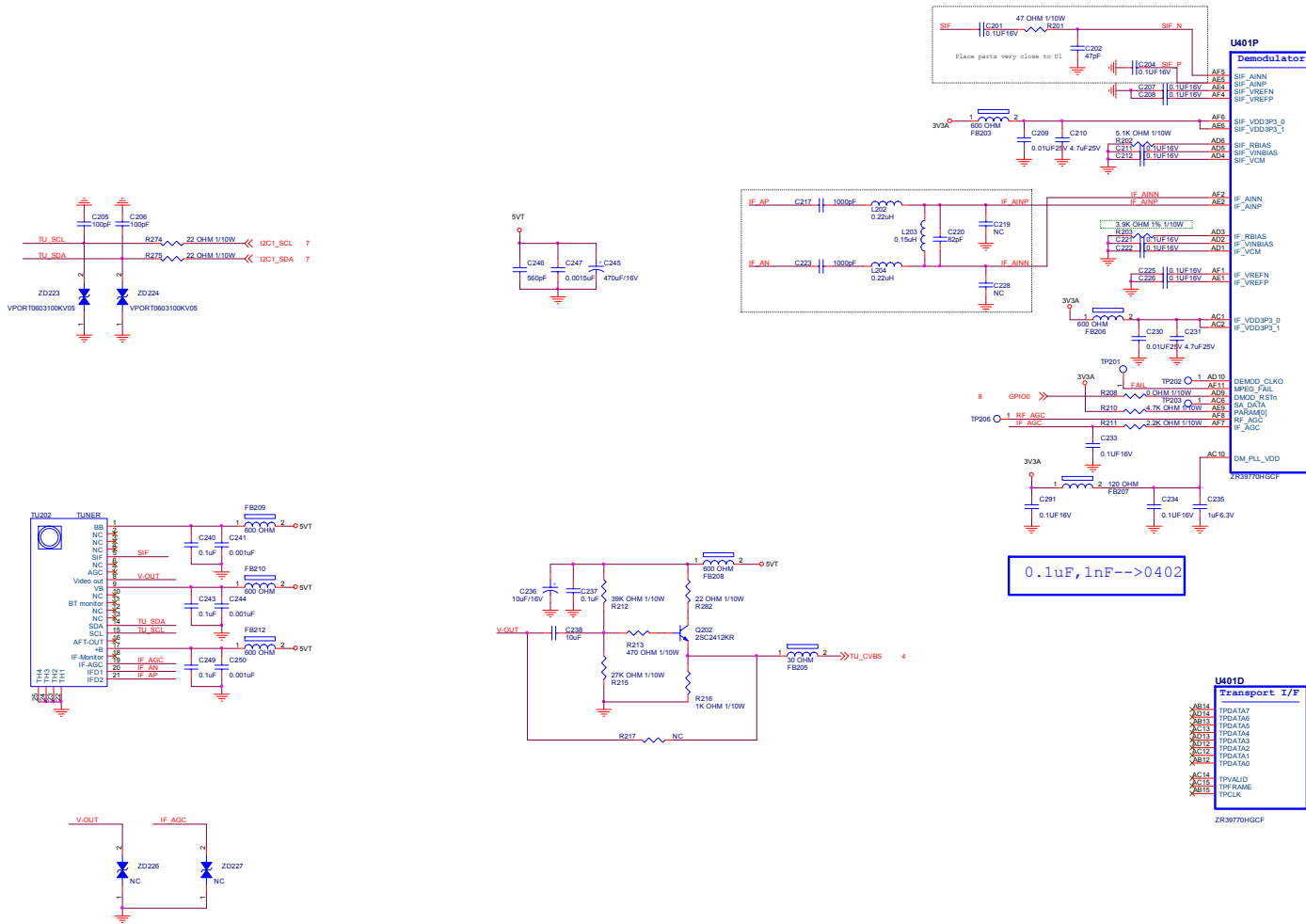

0.1uF, 1nF-->0402

TPV (Top Victory Electronics Co., Ltd.)	OEM MODEL	Size	C
规格书编号: T2763-B-2	TPV MODEL	Rev	E
Key Component: 03-Tuner	PCB NAME: 71512763	张数	<8张>
Date: Thursday, May 08, 2008	Sheet: 3 of 15		

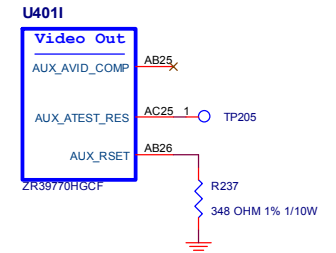
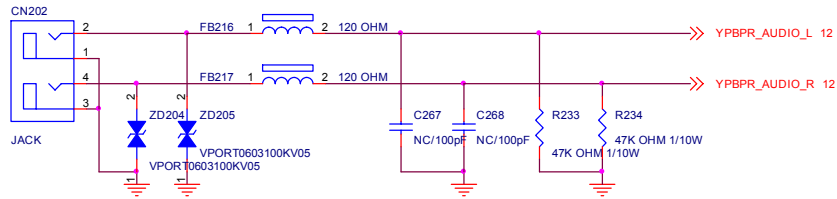
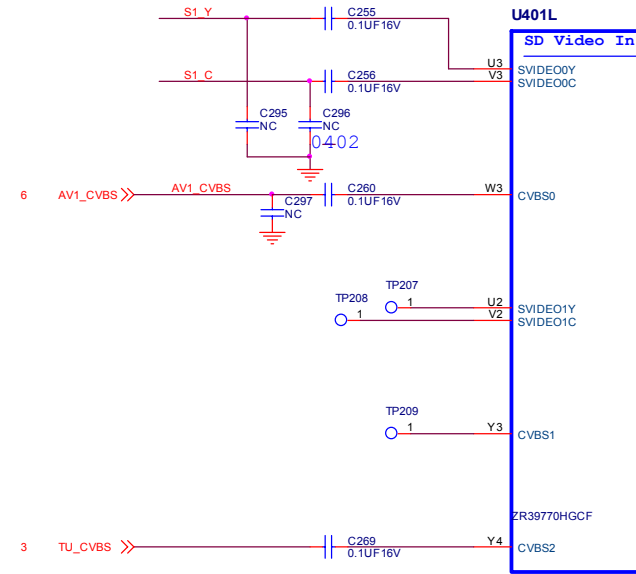
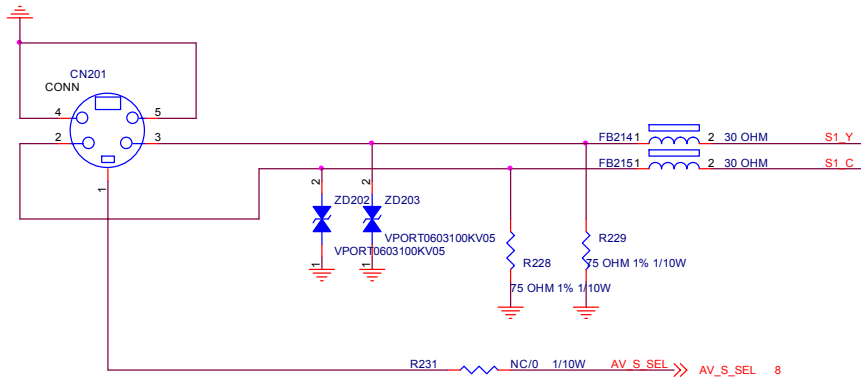

TPV (Top Victory Electronics Co., Ltd.)	OEM MODEL		Size	Custom
錫蘭瓜爾賈	T2763-B-2	TPV MODEL	Rev	E
Key Component	04-AV input	PCB NAME	715T2763	称多 <称多>
Date	Thursday, May 08, 2008	Sheet	4 of 18	

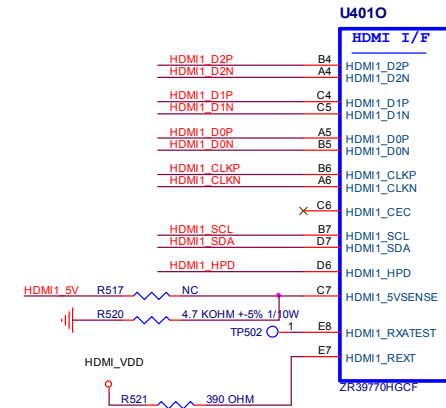
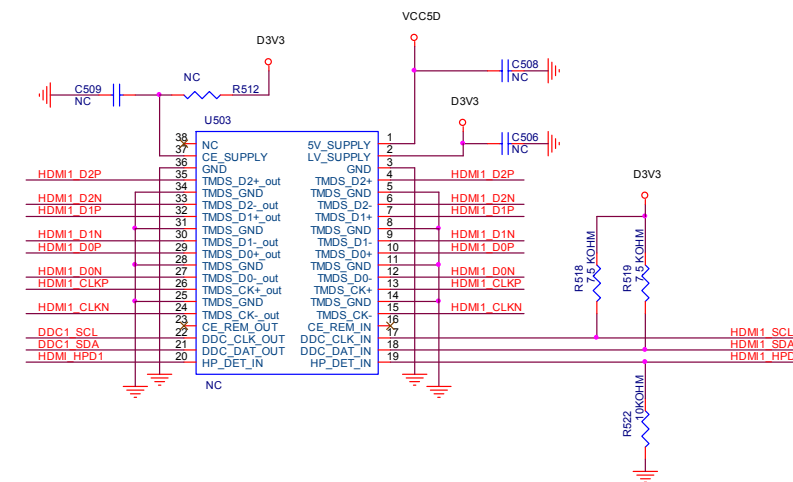
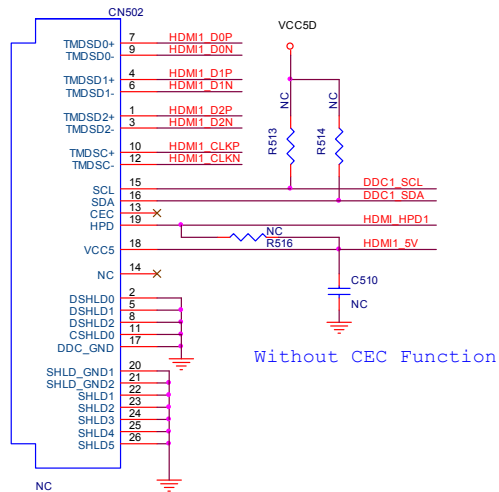
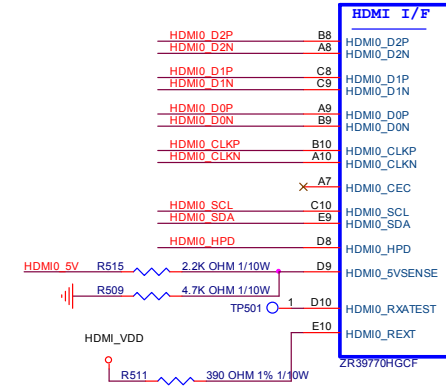
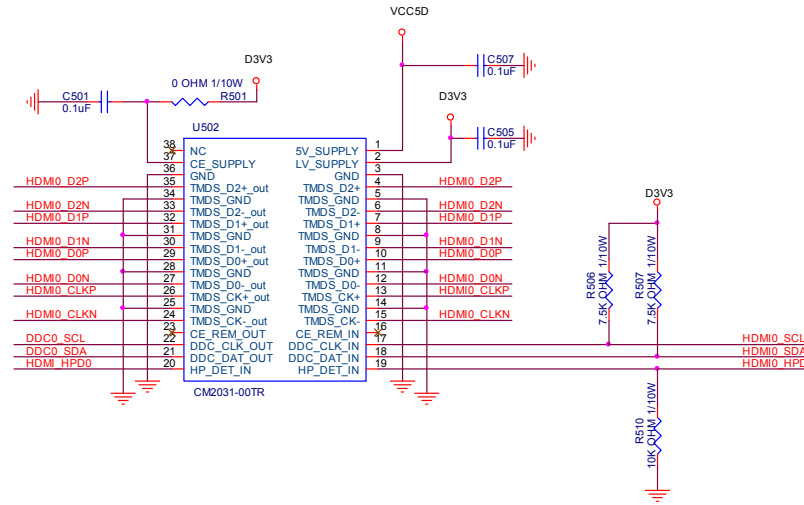
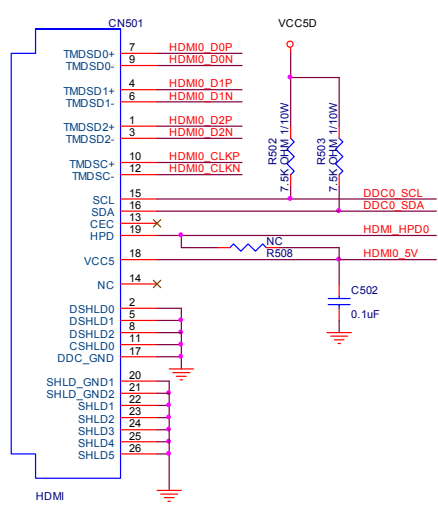

TPV (Top Victory Electronics Co., Ltd.)	OEM MODEL		Size	Custom
紙箱瓜銀廠	T2763-B-2	TPV MODEL	Rev	E
Key Component	05-HDMI Input	PCB NAME	715T2763	
Date	Thursday, May 08, 2008	Sheet	5 of 18	修簽 <修簽>

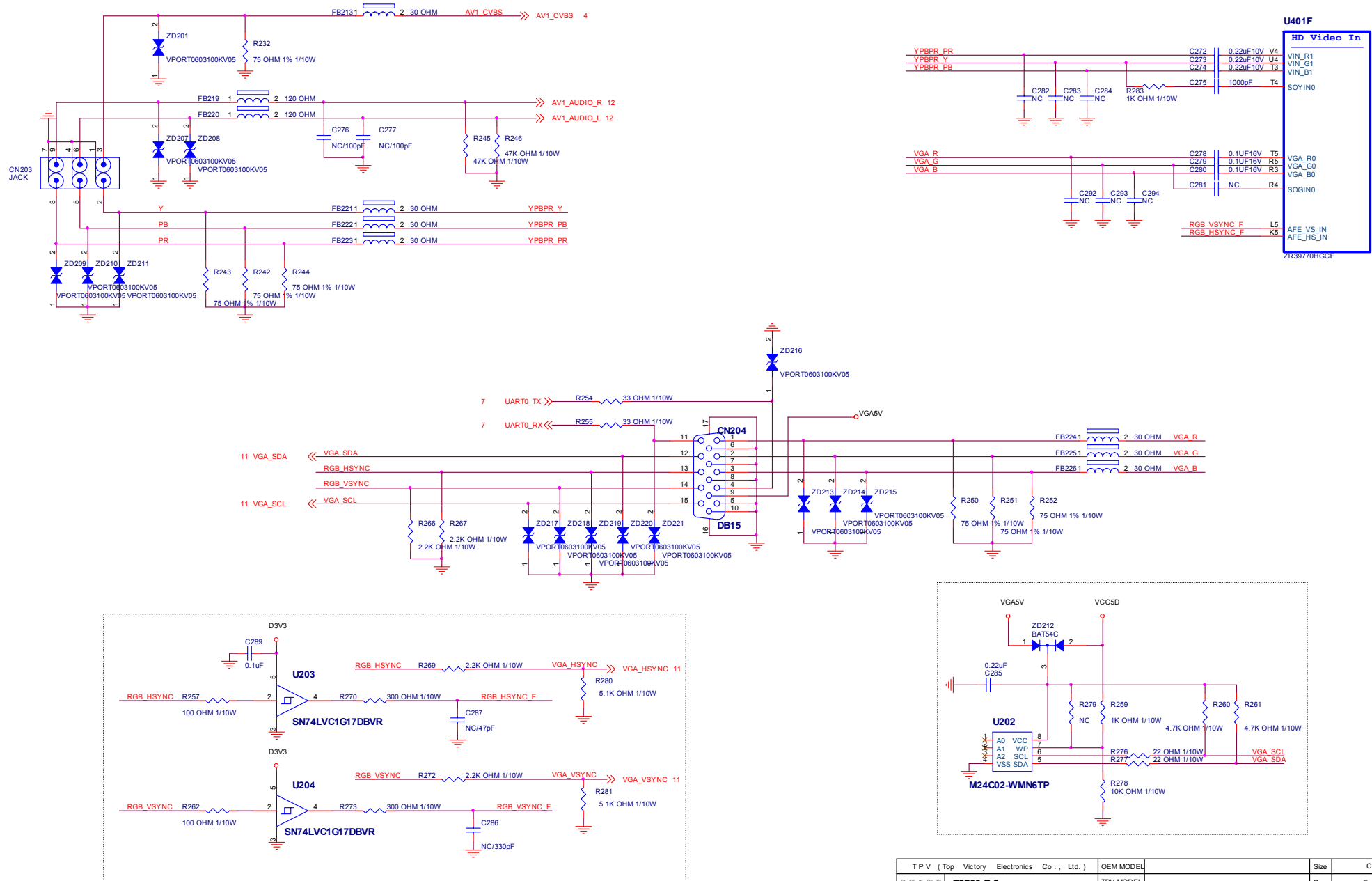

TPV (Top Victory Electronics Co., Ltd.)	OEM MODEL		Size	Custom
新陽成電	T2763-B-2	TPV MODEL	Rev	E
Key Component	06-YPbPr/VGA Input	PCB NAME	715T2763	料號
Date	Thursday, May 08, 2008	Sheet	6 of 18	<轉寄>

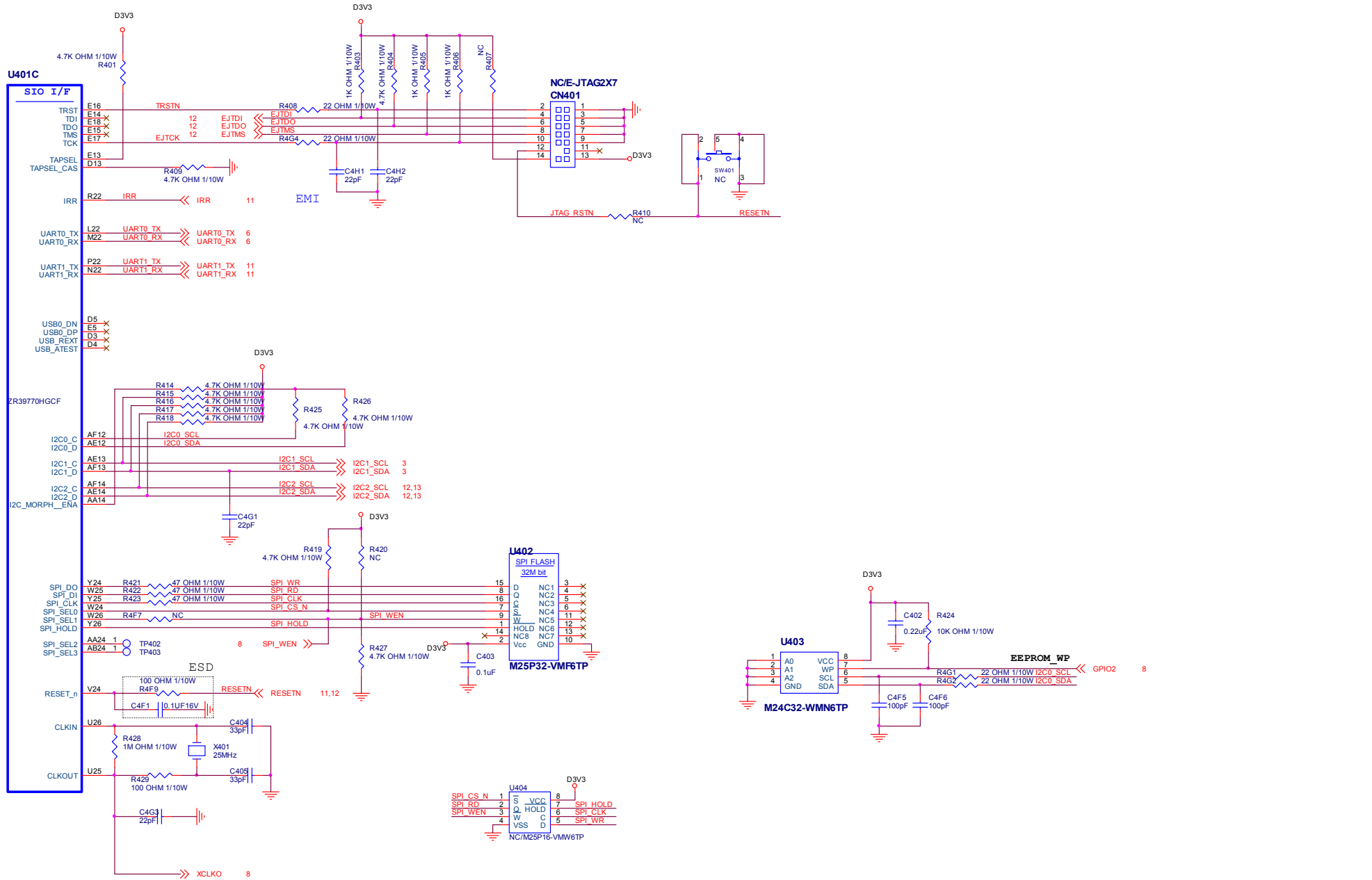

TPV (Top Victory Electronics Co., Ltd.)	OEM MODEL	Size	Custom
括弧内参照 T2763-B-2	TPV MODEL	Rev	E
Key Component 07-SIO I/F	PCB NAME 715T2763	修葺	<修葺>
Date Thursday, May 08, 2008	Sheet 7 of 18		

U401K

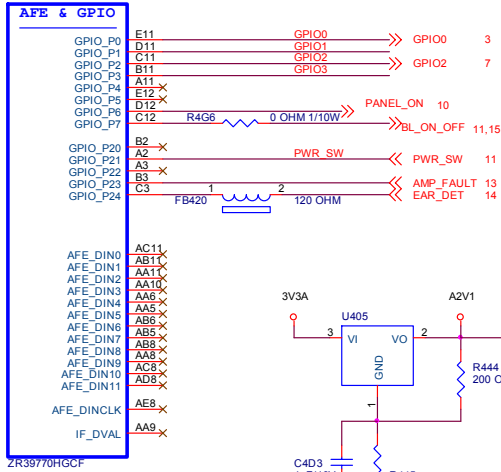

Bootstrap Configuration

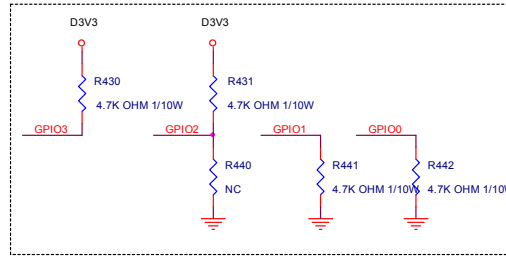

U401M

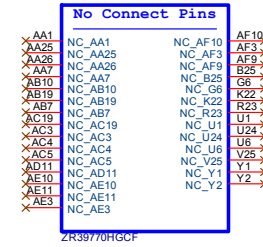

U401S

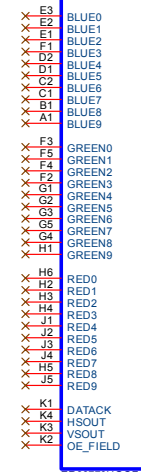

U401H

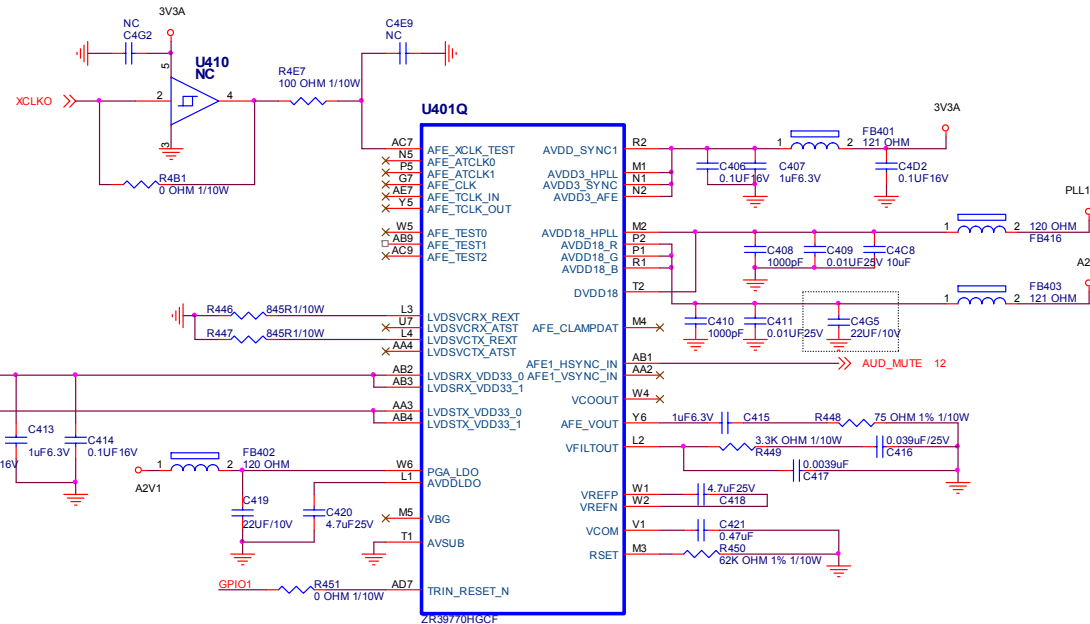
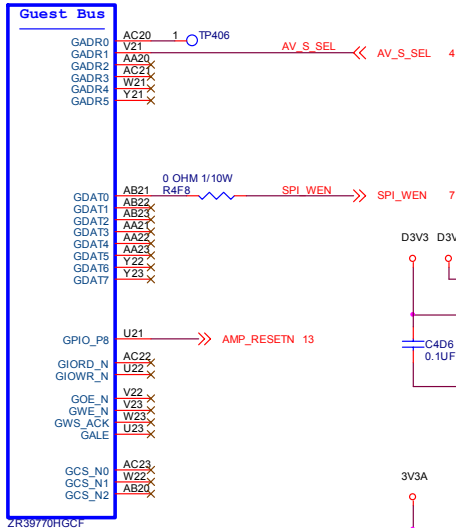

TPV (Top Victory Electronics Co., Ltd.)	OEM MODEL	Size	Custom
話筒瓜 網 廠 T2763-B-2	TPV MODEL	Rev	E
Key Component 08-GPIO Block	PCB NAME 715T2763	稱 號	<稱 號>
Date Thursday, May 08, 2008	Sheet 8 of 18		

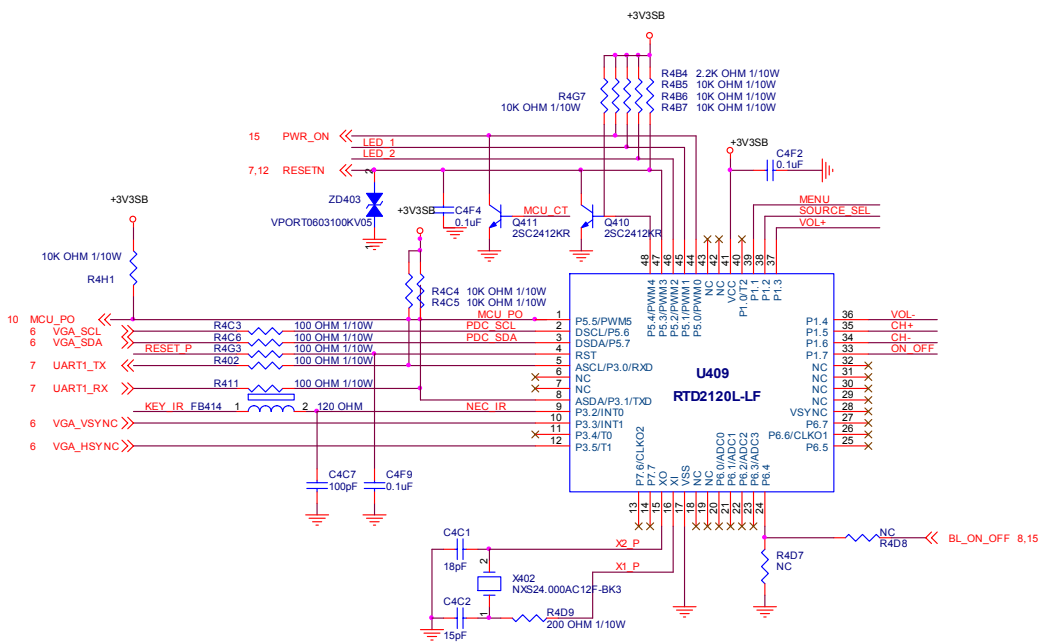
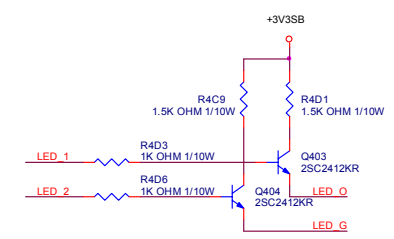
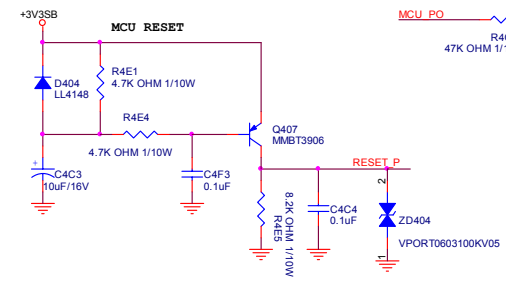
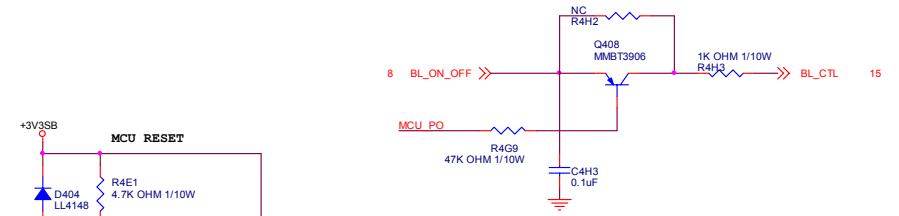
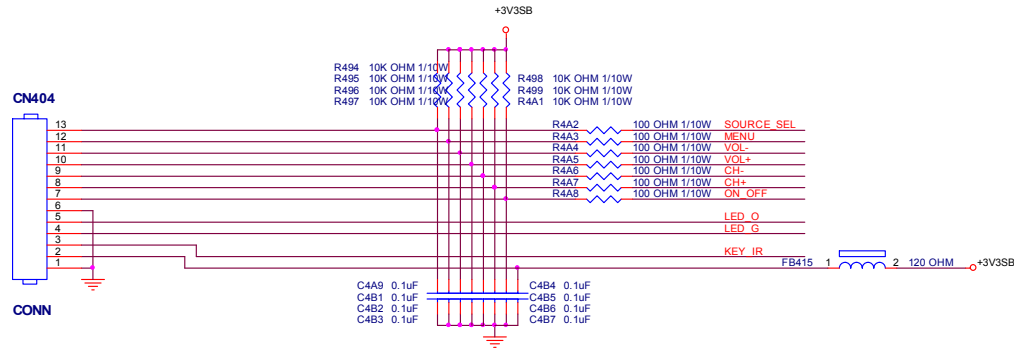

TPV (Top Victory Electronics Co., Ltd.)	OEM MODEL		Size	Custom
威爾瓜爾	T2763-B-2	TPV MODEL	Rev	E
Key Component	11-Standby MCU	PCB NAME	715T2763	修表
Date	Thursday, May 08, 2008	Sheet	11 of 18	<修表>

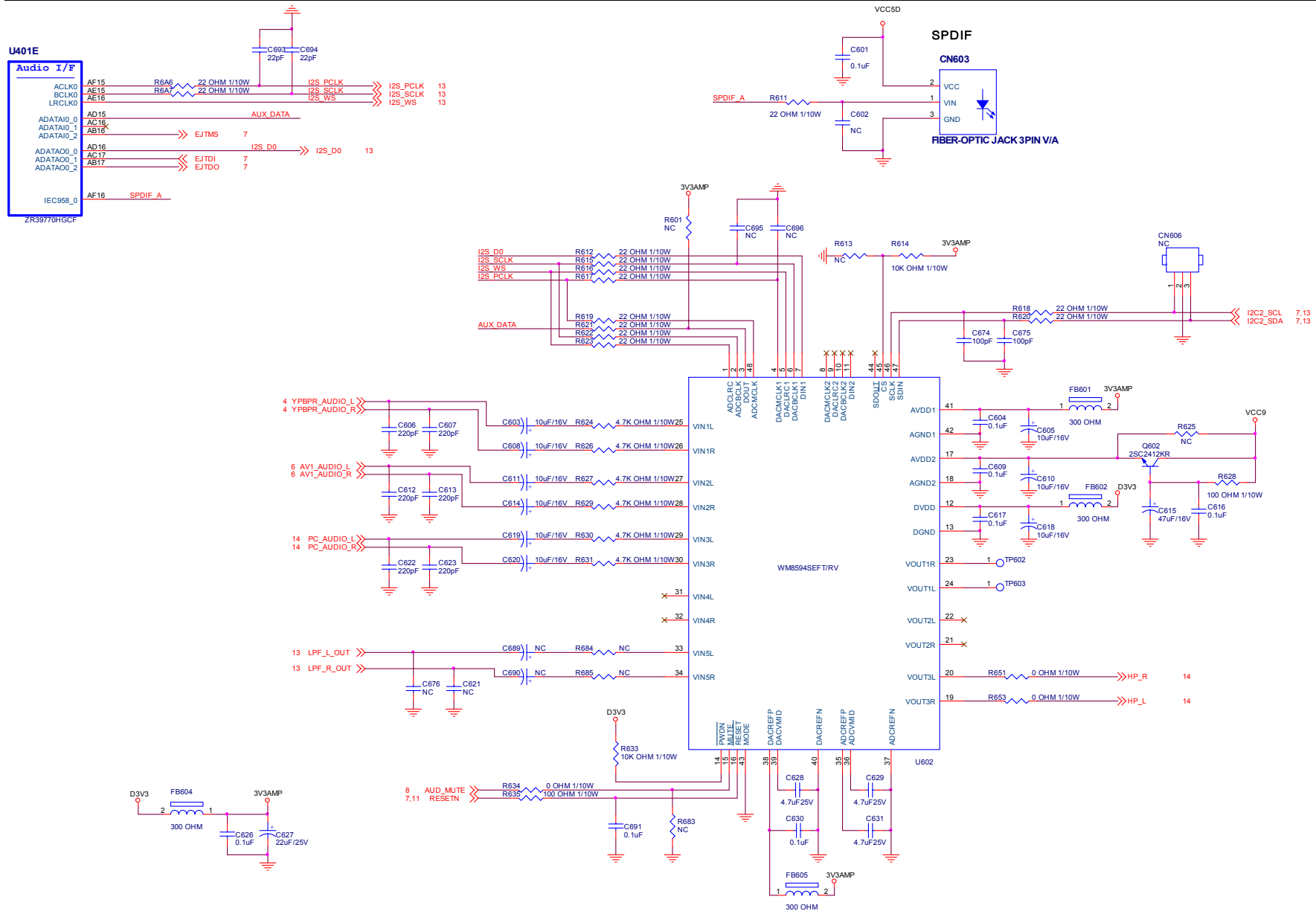

T P V (Top Victory Electronics Co. . Ltd.)	OEM MODEL		Size	Custom
紙箱廠製版	T2763-B-2	TPV MODEL	Rev	E
Key Component	12-Audio Processor	PCB NAME	715T2763	修裝 <修裝>
Date	Thursday, May 08, 2008	Sheet	12 of 18	

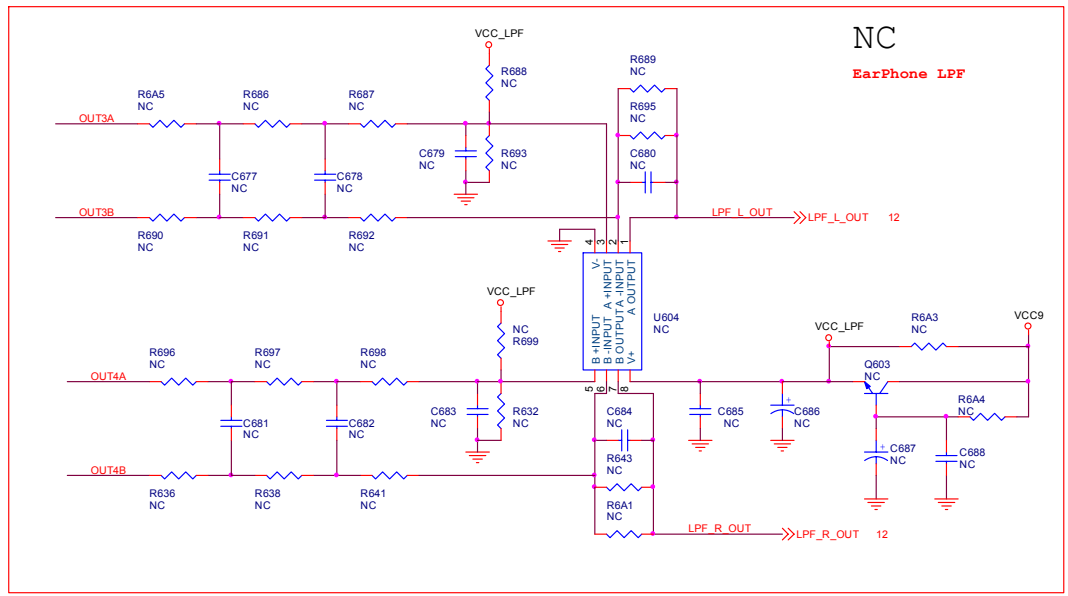
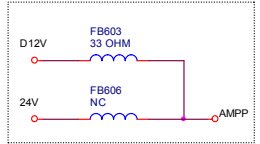
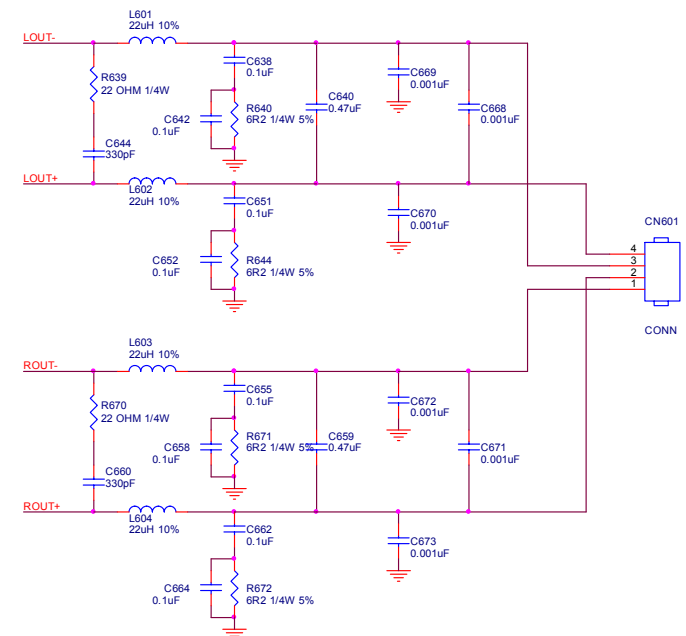
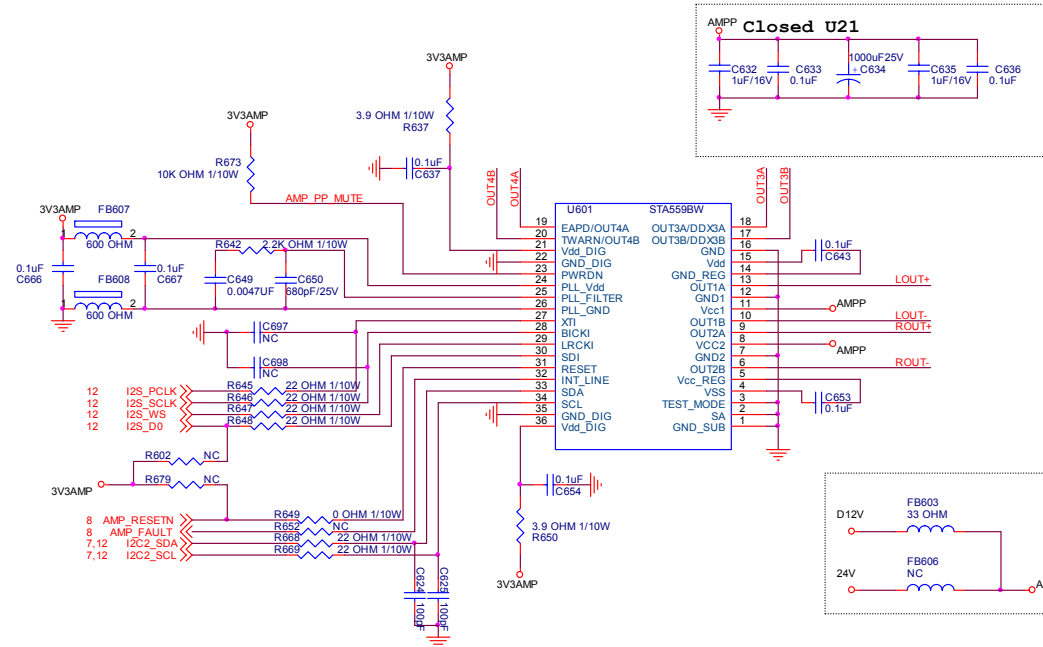

TPV (Top Victory Electronics Co., Ltd.)	OEM MODEL	Size	Custom
話隔瓜網膜	T2763-B-2	TPV MODEL	Rev E
Key Component	13-Audio Amplifier	PCB NAME	715T2763
Date	Thursday, May 08, 2008	Sheet	13 of 18

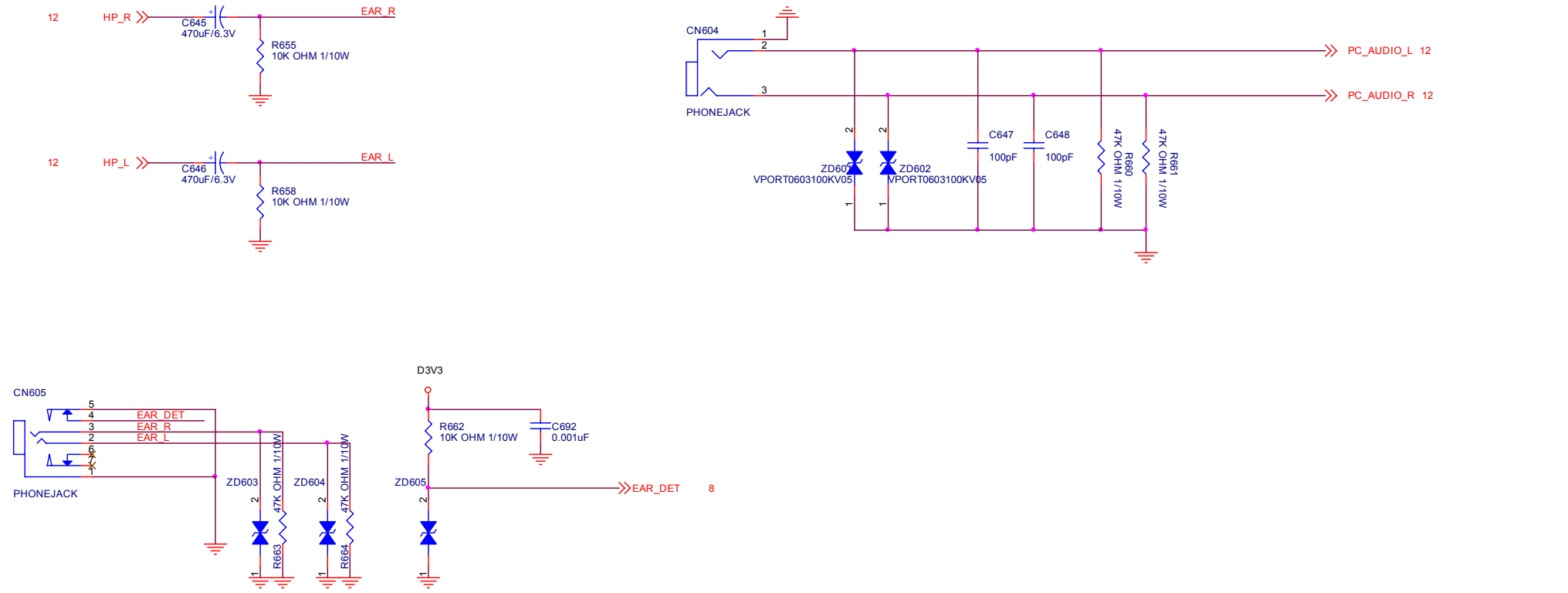

TPV (Top Victory Electronics Co., Ltd.)	OEM MODEL		Size	B
結隔瓜樂服	T2763-B-2	TPV MODEL	Rev	E
Key Component	14-Earphone/AV Output	PCB NAME	715T2763	稱參 <稱參>
Date	Thursday, May 08, 2008	Sheet	14 of 18	

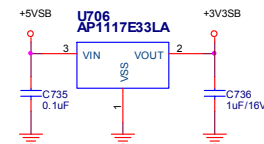
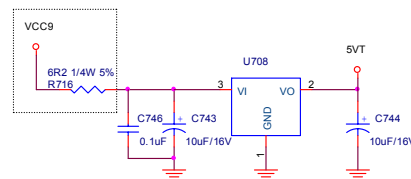
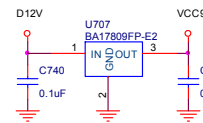
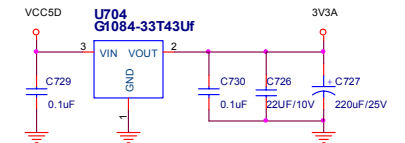
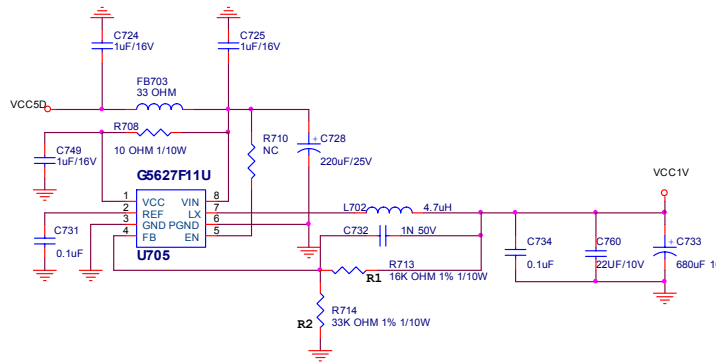
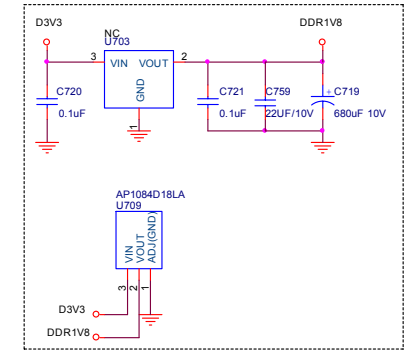
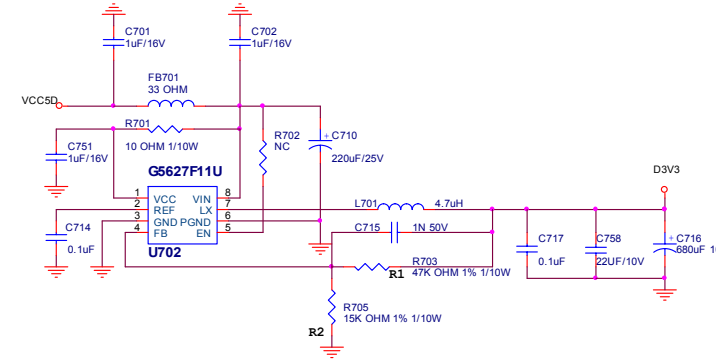
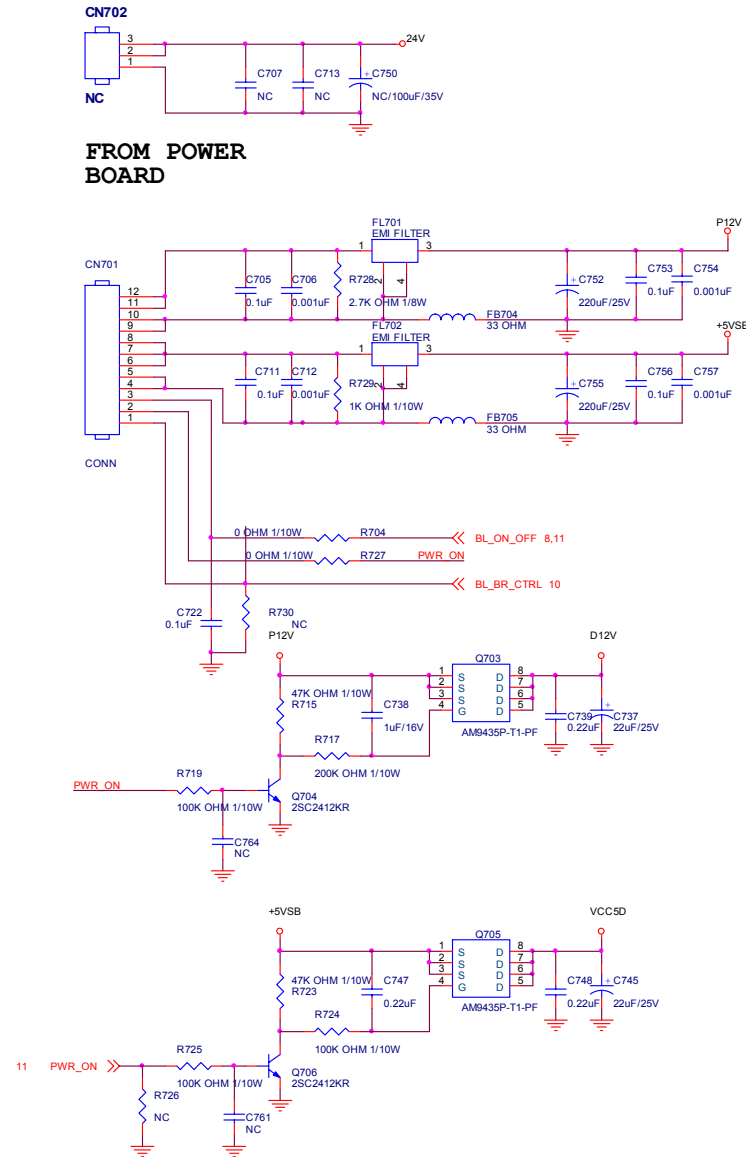

- 5,6,10,12 VCC5D
- 12,13 VCC9
- 3 5VT
- 11 +3V3SB
- 5,6,7,8,10,11,12,14 D3V3
- 3,8 3V3A
- 9,10 DDR1V8
- 10 VCC1V
- 13 24V

TPV (Top Victory Electronics Co., Ltd.)	OEM MODEL		Size	Custom
攝爾瓜 銅廠	T2763-B-2	TPV MODEL	Rev	E
Key Component	15-Power	PCB NAME	715T2763	
Date	Thursday, May 08, 2008	Sheet	15 of 18	修裝 <修裝>

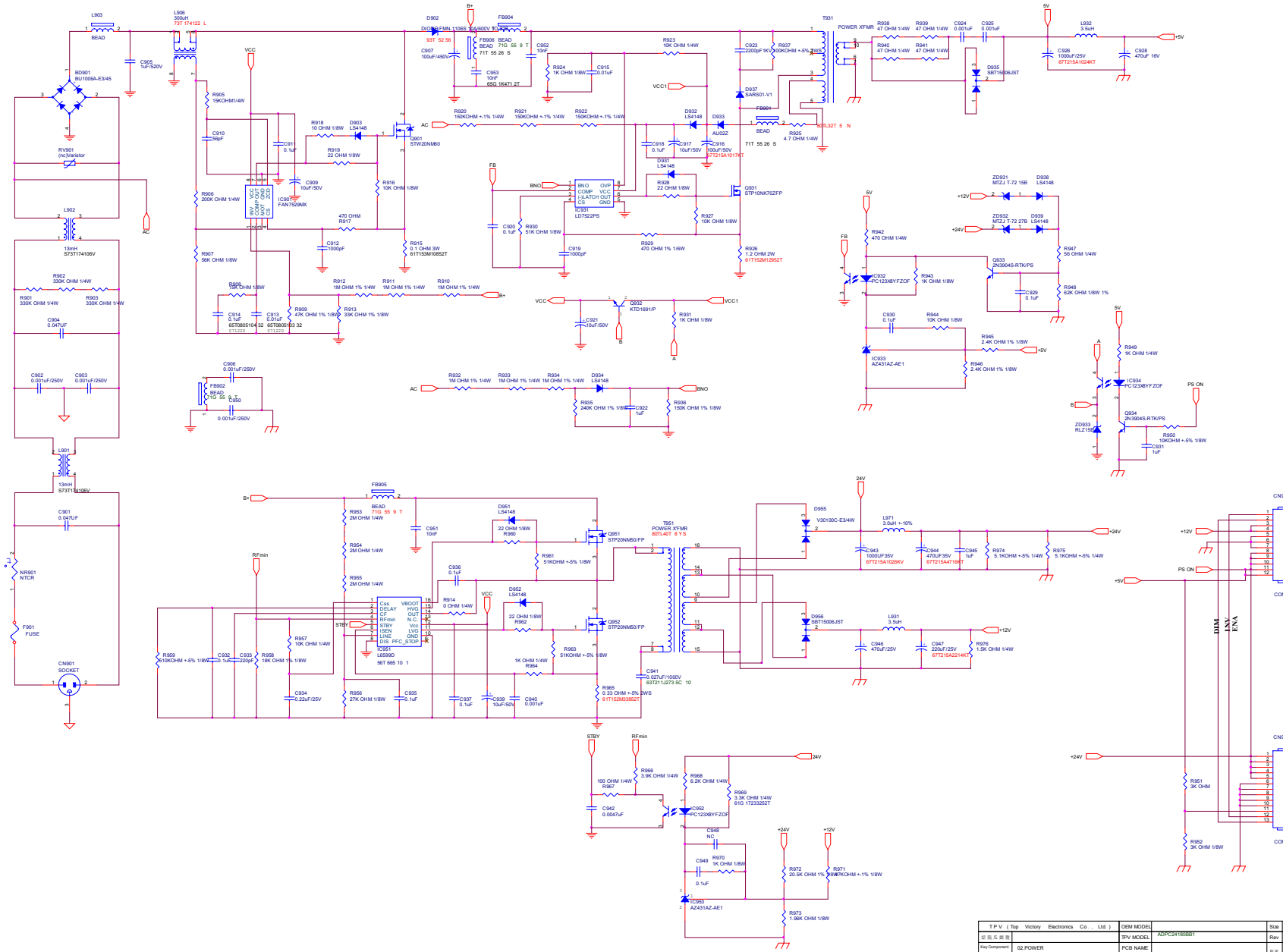

TPV (Top Victory Electronics Co., Ltd)	DEM MODEL	Sta	Custom
Shi Sheng Shi	TPV MODEL	Rev	1.0
Rev:00000002	92 POWER	PCB NAME	
Date	Thursday, January 10, 2008	Sheet	1 of 2

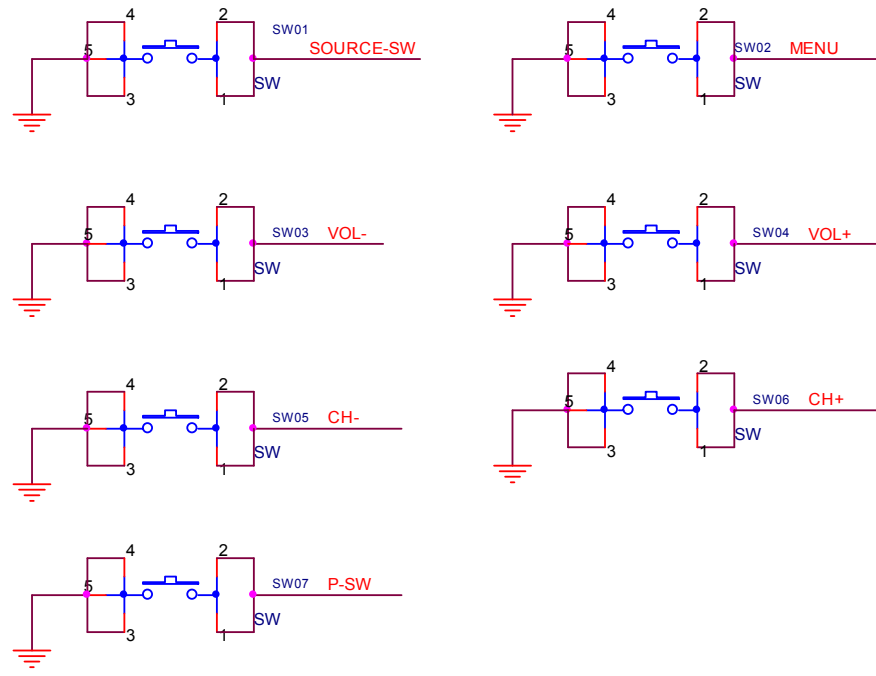
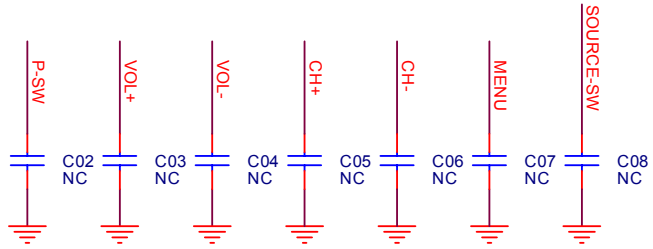
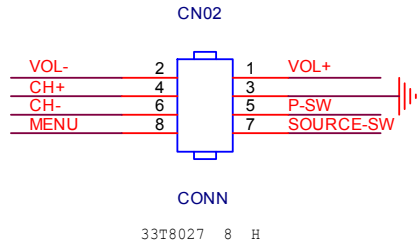

Title		
Size A	Document Number 715T2833	Rev A
Date:	Thursday, August 02, 2007	Sheet 1 of 1

10. Exploded View

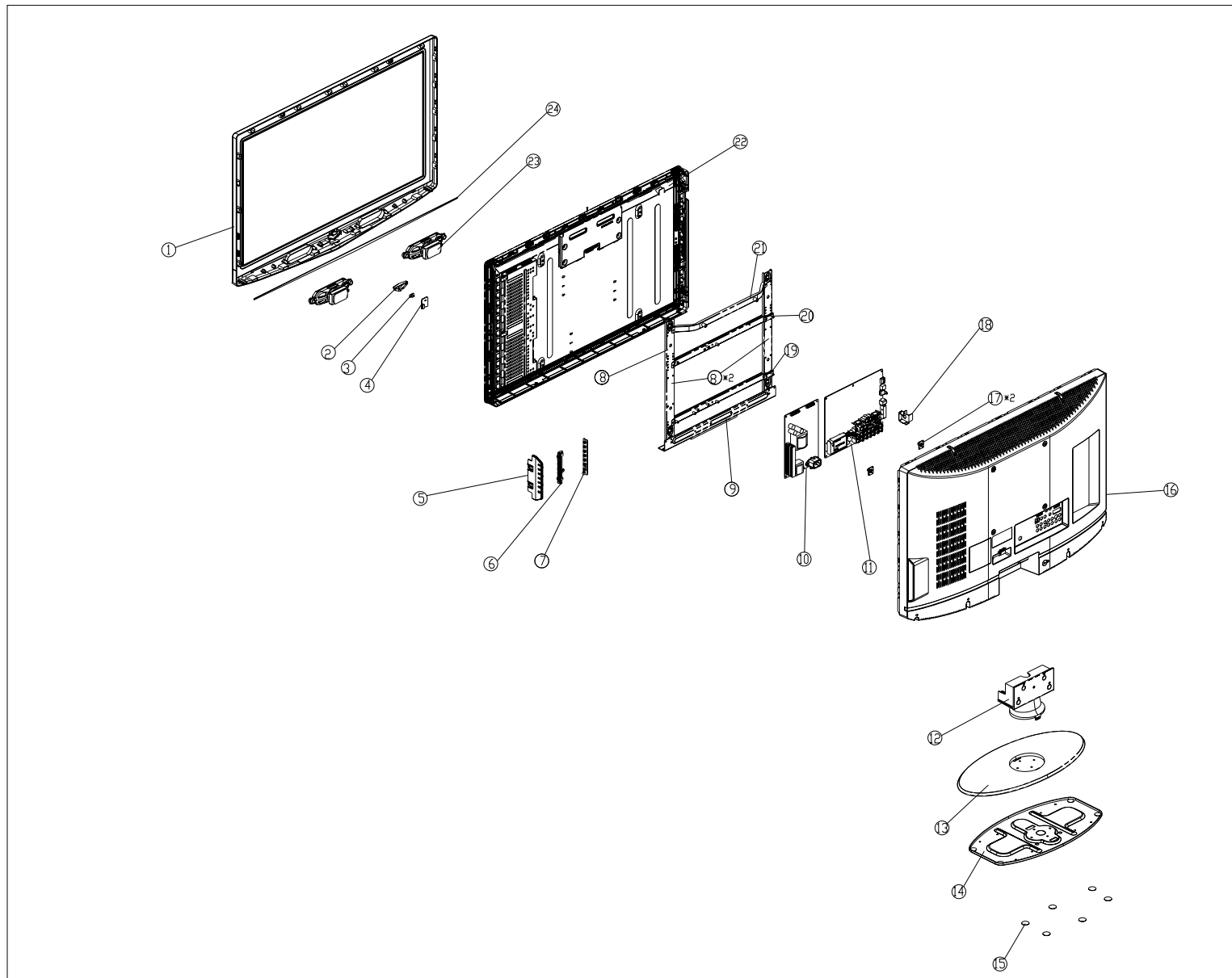

TV32W08 POLAROID EXPLODING				
ITEM	PART NO.	PART NAME	Q'TY	UNIT
1	A34T0517GMKEL0500	BEZEL TV32W-8A3	1	PCS
2	A33T0345 ED 1C0100	LENS_IR	1	PCS
3	A33T0347 1 1C0100	POWER LENS	1	PCS
4	IRPF8QB3	IR BOARD	1	PCS
5	A33T0304 GMC1L0100	COVER_BUTTON	1	PCS
6	A33T0305 QV 1L0200	BUTTON_FUNC	1	PCS
7	KEPF7QAA	KEY BOARD	1	PCS
8	Q15T0309103	BKT-PANEL-SUPPORT	2	PCS
9	A15T0283102	BKT-BASE-SUPPORT	1	PCS
10	ADPC24180BB1	POWER BOARD	1	PCS
11	756TQ8CB ZK018	MAIN BOARD	1	PCS
12	Q37T0078021 GM	HINGE ASS'Y	1	PCS
13	A34T0521 GM 1L0220	BASE_S1	1	PCS
14	A15T0384201	BKT-BASE-PLATE-A1-BIG	1	PCS
15	Q12G6300 25 2	RUBBER FOOT	6	PCS
16	A34T0518 GM 5A0100	REAR COVER 32	1	PCS
17	A15T0282101	BKT-VESA-BTM	2	PCS
18	A15T0306101	SIDE COVER-NAFTA	1	PCS
19	Q15T0308103	BKT-PCB-HOLDER-BTM	1	PCS
20	Q15T0307103	BKT-PCB-HOLDER-TOP	1	PCS
21	Q15T0310101	BKT-VESA-TOP	1	PCS
22	750TVA315Z9411N000	PANEL LK315T3LZ94 JP SHARP	1	PCS
23	078T 495501 Y	SPK 8 OHM 11W 120*30MM SUNLINK	2	PCS
24	Q35T0031 1A1P0200	TRIM_BEZEL	1	PCS

11. BOM List

E32RXZNKW9PV2N

Location	Part No.	Description	REMARK
	044G9003210	CORNER PAPER	
	049T 51 1A	ERADICATOR	
	756TQ8CB ZK018	MAIN BAORD-CBPFRZ5KQ2	
U409	056G1125701 X	IC MCU RTD2120L-LF REALTEK	
U402	056G1133103	IC M25P32-VMF6P 32M s0-16	
CBPF-U409	100TMZMK002KT1	MCU ASS'Y-056G1125701 X	
SMTF-U402	100TMZXK001K11	MCU ASS'Y-056G1133103	
	Q07G 8 3159	compound pallet	
	Q07G 8 3178	compound pallet	
	Q44T6002102 89	PAPER BOARD	
	Q44T6002122 89	PAPER BOARD	
	Q44TJ019008 2B	32" TV CARTON	
	Q50G 500519	CABLE TIE	
	0Q1T 940 14 47 CR3	SCREW	
	Q41T3201008 1A	MANUAL	
	Q41T7830008 2A	STAND ASSEMBLY GUIDE	
	Q41T7830008 3A	QSG	
	Q41T7830008 4A	Return Stopper Insert	
	Q41T7830008 5A	WARRANTY CARD	
	Q44G600024D 3A	carton	
	Q45G 76 28NV2 R	PE BAG FOR CLAMP	
	Q45G2007M0102A	pe bag for manual	
	040T 58162435A	LABEL	
	040T 581654 3A	CARTON LABEL	
	Q40G 582813 3A	S/N LABEL	
	Q40T 320008 2A	RATING LABEL	
	044G3231 15549	EVA WASHER	
	052G 1150 C	INSULATING TAPE	
	052G 1185 1	BIG TAPE	
	052G 1186	SMALL TAPE	
	052G 1211 B	Conductive Tape 85mm *40mm *0.09mm	
	052G 1218 A	SILVER	
	052G 2191 A	PAPER TAPE	
	078T 495501 Y	SPK 8 OHM 11W 120*30mm SUNLINK	
E08901	089G402A18N CX	POWER CORD	
E08901	089G402A18N IS	POWER CORD/(TPV)32-D022438	2ND SOURCE
	092TB1JX1A3WGM	BATTERY FOR ALL EXPORT MODE LR03	
	098TRABD3NEPDC	Remote control For Polaroid	
	0D1G 930 8 47 CR3	SCREW	
	0D1T 940 6120	SCREW	
	0M1G 940 6120	SCREW (M4X6)	
	0M1G 940 10 47 CR3	SCREW	
	0Q1G 930 8 47 CR3	SCREW	
	0Q1T 940 14 47 CR3	SCREW	
	0Q1T1040 8 47 CR3	SCREW	
	705TQ8SK118	SKD ASS'Y	
	036T 600 18112	NONWOVEN FABRTC	
E09501	095T8013 4D642	HARNESS 4P-B&R(750MM)+B&W(550MM)	2ND SOURCE

32"LCD TV

Polaroid TLM-23201B

E09501	095T8013 4X642	HARNESS 4P-B&R(750MM)+B&W(550MM)	
E09505	095T801312W654	WIRE HARNESS 12P(PLUG)-12P(PLUG)	2ND SOURCE
E09505	095T801312X654	WIRE HARNESS 12P(PLUG)-12P(PLUG)	
E09502	095T801413W661	WIRE HARNESS 13P-5P(PLUG)+8P(DF11)	2ND SOURCE
E09502	095T801413X661	WIRE HARNESS 13P-5P(PLUG)+8P(DF11)	
E09503	095T801414WH42	WIRE HARNESS 14P-13P	2ND SOURCE
E09503	095T801414XH42	WIRE HARNESS 14P-13P	
	095T8018 3XH35	LVDS CABLE 30P-24P 230MM	
	0D1T 940 6120	SCREW	
	0M1G1730 6120	SCREW,42-D020523	
	0M1G1730 10120	SCREW 42A9930016	
	0M1G1740 6120	SCREW	
	0M1T 340 4120	SCREW	
	0M1T 960 10120	SCREW	
	0Q1T 940 14 47 CR3	SCREW	
	705TQ734489	REAR COVER ASS'Y	
	A15T0282101	bkt-vesa-btm	
	A34T0518 GM 5A0100	Rear Cover 32	
	Q36T 600 18113	CLOTH_GRIDDING	
	Q36T 600 18120	.LOTH_GRIDDING	
	Q36T 600 37 36 GP	NONWOVEN FABRIC	
	705TQ734491	STAND ASS'Y	
	0Q1G 130 8120	SCREW 42A9930011	
	A15T0384201	bkt-base-plate-a1-big	
	A34T0521 GM 1L0220	BASE_S1	
	Q12G6300 25 2	rubber foot	
M037	Q37T0078021 GM	Hinge Ass'y	
M037	SQ37T0078021G	HINGE ASSY	2ND SOURCE
	705TQ833063	PLASTIC ASS'Y	
	012G6066 1	RUBBER FOOT	
	0Q1G 930 6120	SCREW 3X6MM	
	A33T0304 GMC1L0100	COVER_BUTTON	
	A33T0305 QV 1L0200	BUTTON_FUNC	
	KEPF7QAA	KEY board ASSY	
CN02	033G8027 8 H	WAFER 8P 2.0mm DIP DUAL ROWR	
SW01	077G 600 1GCJ	TACT SWITCH TSPB-2 -NP	
SW05	077G 600 1GCJ	TACT SWITCH TSPB-2 -NP	
SW06	077G 600 1GCJ	TACT SWITCH TSPB-2 -NP	
SW07	077G 600 1GCJ	TACT SWITCH TSPB-2 -NP	
SW03	077G 600 1GCJ	TACT SWITCH TSPB-2 -NP	
SW04	077G 600 1GCJ	TACT SWITCH TSPB-2 -NP	
SW02	077G 600 1GCJ	TACT SWITCH TSPB-2 -NP	
	715T2833 1	KEY PCB	
	705TQ834621	BEZEL ASS'Y	
	A33T0345 ED 1C0100	ir lens-a3	
	A33T0347 1 1C0100	Power LENS-a3	
	A34T0517 GMKEL0500	BEZEL TV32W-8A3	
	A15T0283102	bkt-base-support	
	A15T0306101	Side Cover-NAFTA	
	ADPC24180BB1	POWER BAORD	
	040G 45762412B	CBPC LABEL	

CN902	033T327812D	WAFER 12P PLUG	
CN903	033T380213B Y	CONNECTOR	
IC932	056G 139 3B	IC PC123Y82FZ0F	
IC952	056G 139 3B	IC PC123Y82FZ0F	
IC934	056G 139 3B	IC PC123Y82FZ0F	
Q932	057G 761 7	KTD1691P	
R915	061T153M10852T	RST MOFR 0.1 OHM +-5% 3WS	
C901	063G107K474 US	0.47UF +-10%	
C904	063G107K474 US	0.47UF +-10%	
C905	063G210K105BCN	MPP CAP 1uF 520V P=15mm	
C941	063G211J273 5C 10	0.027uF 5% 1000V P=15mm	
C951	065G 1K103 2E6921	CAP CER 10NF K 1KV Y5P	
C952	065G 1K103 2E6921	CAP CER 10NF K 1KV Y5P	
C906	065G306M1022BM GP	Y1.CAP.001UF 250VAC MURATA	
C950	065G306M1022BM GP	Y1.CAP.001UF 250VAC MURATA	
C903	065G306M1022BM GP	Y1.CAP.001UF 250VAC MURATA	
C902	065G306M1022BM GP	Y1.CAP.001UF 250VAC MURATA	
C926	067G215A1024KV	EC 1000uF 25V 12.5*20mm	
C943	067G215A1026KV	EC 1000uF 35V 12.5*25mm	
C928	067G215A4713KV	EC 470uF 16V M 10*12mm	
C944	067G215A4716KV	EC 470uF 35V M 10*16mm	
C946	067G215S4714KL	LOW ESR EC 470UF 25V BY 金山	
L903	071G 55 21	FERRITE BEAD	
FB906	071T 55 26 S	FERRITE CORE	
FB901	071T 55 26 S	FERRITE CORE	
L932	073G 253 91 H	CHOKE COIL	
L931	073G 253 91 H	CHOKE COIL	
L971	073G 253150 L	CHOCK	
L901	073T 174106 V	LINE FILTER 13mH MIN	
L902	073T 174106 V	LINE FILTER 13mH MIN	
L906	073T 174122 L	PFC CHOKE 230uH PT-009321	
T931	080TL32T 5 N	X'FMR 1.9mH YUVA-827	
T951	080TL40T 8 YS	X'FMR 600uH YS04160149	
CN901	087T 501 44 DL	AC SOCKET 3PIN + 2 SCREW Hole V/T	
	705TQ757011	Q951 ASS'Y	
Q951	057G 611 9	FET 2SK4097LS 9.5A/500V TO-220FI(LS)	
	0M1G1730 8120	SCREW	
	Q90G6084 3	heat sink	
	705TQ757012	Q952 ASS'Y	
Q952	057G 611 9	FET 2SK4097LS 9.5A/500V TO-220FI(LS)	
	0M1G1730 8120	SCREW	
	Q90G6084 3	heat sink	
	705TQ757013	Q931 ASS'Y	
Q931	057G 667 52	FET 2SK4100LS-T 7A/650V TO-220FI(LS)	
	0M1G1730 8120	SCREW	
	Q90G6084 3	heat sink	
	705TQ757022	Q901 ASS'Y	
Q901	057G 600 72	FET SPW16N50C3 16A/560V P-TO247	
	0M1G1730 10120	SCREW 42A9930016	
	Q12G 372 8	SILICON	
	Q90T0095 2	HEAT SINK	

	705TQ761021	NR901 ASS'Y	
NR901	061T 58030 WL	RST NTCR 3 OHM +-20% 5A THINKING	
	Q09T 203 8	PIN	
	705TQ793020	BD901 ASS'Y	
BD901	093G 50460 39	BRIDGE BU1006A-E3/45 10A/600V BU	
	0M1G1730 10120	SCREW 42A9930016	
	Q90T0095 2	HEAT SINK	
	705TQ793021	D902 ASS'Y	
D902	093G 52 56	DIODE FMN-1106S 10A/600V TO-220	
	0M1G1730 8120	SCREW	
	Q90G6084 3	heat sink	
	705TQ793022	D935 ASS'Y	
D935	093G 60298	DIODE SBT15006JST 15A/60V TO-220ML(LS)	
	0M1G1730 8120	SCREW	
	Q90G6084 3	heat sink	
	705TQ793023	D955/D956 ASS'Y	
	005G 42 1	CUSHION	
	032G3028 8	MICA	
	051G 200 1	OIL FOR DISAPPEAR	
D956	093G 60298	DIODE SBT15006JST 15A/60V TO-220ML(LS)	
D955	093G 60310	DIODE V30100C-E3/4W 30A/100V TO-220AB	
	0M1G1730 10120	SCREW 42A9930016	
	Q90T0087 2	HEAT SINK	
IC901	056G 368 12	IC FAN7529MX SOP-8	
IC931	056G 379 79	IC LD7522PS SOP-8	
IC951	056G 665 10 1	IC RESONANT L6599DTR SO-16N ST	
Q933	057G 417 12 T	KEC 2N3904S-RTK/PS	
Q934	057G 417 12 T	KEC 2N3904S-RTK/PS	
R918	061G0805100	RST CHIPR 10 OHM +-5% 1/8W	
R970	061G0805102	RST CHIPR 1K OHM +-5% 1/8W	
R943	061G0805102	RST CHIPR 1K OHM +-5% 1/8W	
R931	061G0805102	RST CHIPR 1K OHM +-5% 1/8W	
R924	061G0805102	RST CHIPR 1K OHM +-5% 1/8W	
R916	061G0805103	RST CHIPR 10K OHM +-5% 1/8W	
R927	061G0805103	RST CHIPR 10K OHM +-5% 1/8W	
R944	061G0805103	RST CHIPR 10K OHM +-5% 1/8W	
R950	061G0805103	RST CHIPR 10K OHM +-5% 1/8W	
R936	061G0805150 3F	RST CHIP 150K 1/8W 1%	
R908	061G0805153	RST CHIPR 15KOHM +-5% 1/8W	
R958	061G0805180 2F	RST CHIPR 18 KOHM +-1% 1/8W	
R973	061G0805196 1F	RST CHIP 1.96K 1/8W 1%	
R972	061G0805205 2F	RST CHIPR 20.5KOHM +-1% 1/8W	
R962	061G0805220	RST CHIPR 22 OHM +-5% 1/8W	
R960	061G0805220	RST CHIPR 22 OHM +-5% 1/8W	
R928	061G0805220	RST CHIPR 22 OHM +-5% 1/8W	
R919	061G0805220	RST CHIPR 22 OHM +-5% 1/8W	
R946	061G0805240 1F	RST CHIPR 2.4K OHM +-1% 1/8W	
R945	061G0805240 1F	RST CHIPR 2.4K OHM +-1% 1/8W	
R935	061G0805240 3F	RST CHIPR 240 KOHM +-1% 1/8W	
R956	061G0805273	RST CHIPR 27 KOHM +-5% 1/8W	
R952	061G0805302	RST CHIPR 3K OHM +-5% 1/8W	

R913	061G0805330 2F	RST CHIPR 33K OHM +-1% 1/8W	
R971	061G0805470 2F	RST CHIP 47K 1/8W 1%	
R909	061G0805470 2F	RST CHIP 47K 1/8W 1%	
R930	061G0805513	RST CHIPR 51K OHM +-5% 1/8W	
R961	061G0805513	RST CHIPR 51K OHM +-5% 1/8W	
R963	061G0805513	RST CHIPR 51K OHM +-5% 1/8W	
R959	061G0805514	RST CHIPR 510 KOHM +-5% 1/8W	
R907	061G0805563	RST CHIPR 56K OHM +-5% 1/8W	
R948	061G0805620 2F	RST CHIPR 62 KOHM +-1% 1/8W	
R914	061G1206000	RST CHIP MAX 0R05 1/4W	
R911	061G1206100 4F	RST CHIPR 1 MOHM +-1% 1/4W	
R932	061G1206100 4F	RST CHIPR 1 MOHM +-1% 1/4W	
R934	061G1206100 4F	RST CHIPR 1 MOHM +-1% 1/4W	
R910	061G1206100 4F	RST CHIPR 1 MOHM +-1% 1/4W	
R933	061G1206100 4F	RST CHIPR 1 MOHM +-1% 1/4W	
R912	061G1206100 4F	RST CHIPR 1 MOHM +-1% 1/4W	
R922	061G1206150 3F	RST CHIPR 150KOHM +-1% 1/4W	
R921	061G1206150 3F	RST CHIPR 150KOHM +-1% 1/4W	
R920	061G1206150 3F	RST CHIPR 150KOHM +-1% 1/4W	
R976	061G1206152	RST CHIPR 1.5 KOHM +-5% 1/4W	
R905	061G1206153	RST CHIPR 15 KOHM +-5% 1/4W	
R906	061G1206204	RST CHIPR 200 KOHM +-5% 1/4W	
R953	061G1206205	RST CHIPR 2 MOHM +-5% 1/4W	
R954	061G1206205	RST CHIPR 2 MOHM +-5% 1/4W	
R955	061G1206205	RST CHIPR 2 MOHM +-5% 1/4W	
R901	061G1206334	RST CHIPR 330KOHM +-5% 1/4W	
R902	061G1206334	RST CHIPR 330KOHM +-5% 1/4W	
R903	061G1206334	RST CHIPR 330KOHM +-5% 1/4W	
R938	061G1206470	RST CHIPR 47 OHM +-5% 1/4W	
R939	061G1206470	RST CHIPR 47 OHM +-5% 1/4W	
R940	061G1206470	RST CHIPR 47 OHM +-5% 1/4W	
R941	061G1206470	RST CHIPR 47 OHM +-5% 1/4W	
R925	061G1206479	RST CHIPR 4.7OHM +-5% 1/4W	
R975	061G1206512	RST CHIPR 5.1 KOHM +-5% 1/4W	
R974	061G1206512	RST CHIPR 5.1 KOHM +-5% 1/4W	
C919	065G0805102 31	CAP CHIP 0805 1000PF J 50V NPO	
C912	065G0805102 31	CAP CHIP 0805 1000PF J 50V NPO	
C925	065G0805102 32	CHIP 1000P 50VX7R 0805	
C924	065G0805102 32	CHIP 1000P 50VX7R 0805	
C940	065G0805102 32	CHIP 1000P 50VX7R 0805	
C913	065G0805103 32	CAP CHIP 0805 10NF K 50V X7R	
C915	065G0805103 32	CAP CHIP 0805 10NF K 50V X7R	
C914	065G0805104 32	CAP CHIP 0805 0.1uF K 50V X7R	
C949	065G0805104 32	CAP CHIP 0805 0.1uF K 50V X7R	
C920	065G0805104 32	CAP CHIP 0805 0.1uF K 50V X7R	
C937	065G0805104 32	CAP CHIP 0805 0.1uF K 50V X7R	
C936	065G0805104 32	CAP CHIP 0805 0.1uF K 50V X7R	
C935	065G0805104 32	CAP CHIP 0805 0.1uF K 50V X7R	
C932	065G0805104 32	CAP CHIP 0805 0.1uF K 50V X7R	
C930	065G0805104 32	CAP CHIP 0805 0.1uF K 50V X7R	
C929	065G0805104 32	CAP CHIP 0805 0.1uF K 50V X7R	

C918	065G0805104 32	CAP CHIP 0805 0.1uF K 50V X7R	
C911	065G0805104 32	CAP CHIP 0805 0.1uF K 50V X7R	
C922	065G0805105 37	CHIP 1UF 50V Y5V	
C931	065G0805105 37	CHIP 1UF 50V Y5V	
C945	065G0805105 37	CHIP 1UF 50V Y5V	
C933	065G0805221 31	CAP CHIP 0805 220PF J 50V NPO	
C934	065G0805224 22	CAIP CAP 0.22 uF 25V X7R	
C942	065G0805472 32	CAP CHIP 0805 4700PF K 50V X7R	
C910	065G0805560 31	MLCC 0805 56PF J 50V NP0	
ZD933	093G 39S 15 T	RLZ15B LLDS	
D932	093G 64S901 T	DIODE LS4148	
D938	093G 64S901 T	DIODE LS4148	
D951	093G 64S901 T	DIODE LS4148	
D952	093G 64S901 T	DIODE LS4148	
D939	093G 64S901 T	DIODE LS4148	
D934	093G 64S901 T	DIODE LS4148	
D931	093G 64S901 T	DIODE LS4148	
D903	093G 64S901 T	DIODE LS4148	
T951	006G 31 4	1.7MM RIVET	
	006G 31 4	1.7MM RIVET	
CN901	006G 31501	EYELET	
IC933	056G 158 10 T	IC AS431AZTR-E1 TO-92	
IC953	056G 158 10 T	IC AS431AZTR-E1 TO-92	
R949	061G 17210252T	1K OHM 5% 1/4W	
R964	061G 17210252T	1K OHM 5% 1/4W	
R957	061G 17210352T	CFR 10KOHM +-5% 1/4W	
R923	061G 17210352T	CFR 10KOHM +-5% 1/4W	
R969	061G 17233252T	3.3K 1/4W	
R942	061G 17247152T	470OHM 5% 1/4W	
R951	061G 21030252T	3KOHM 1% 1/6W	
R929	061G 21047152T	470 OHM 1% 1/6W	
R917	061G 60247152T	470OHM +-5% 1/6W	
R965	061G152M33852T	RST MOFR 0.33 OHM +-5% 2WS	
R937	061G208M10452T	RST MOF 100K 5% 1W	
R947	061T 17256052T	RST CFR 56 OHM +-5% 1/4W	
R968	061T 17262252T	6.2KPHM 5% 1/4W	
R967	061T 20010152T	100 OHM 1% 1/4W	
R966	061T 20039252T	RST MFR 3.9KOHM +-1% 1/4W	
R926	061T152M12952T	RST MOFR 1.2OHM +-5% 2WS	
C923	065G 1K222 2T6921	CAP CER 2200PF K 1KV	
C953	065G 1K471 2T	470pF 1KV Z5P +-10%	
C916	067G215A1017KT	EC 100uF 50V 8*12mm	
C947	067G215A2214KT	EC 220uF 25V 8*12mm	
C909	067G215Y1007KT	KY50VB10M-TP5 5*11.5	
C917	067G215Y1007KT	KY50VB10M-TP5 5*11.5	
C921	067G215Y1007KT	KY50VB10M-TP5 5*11.5	
C939	067G215Y1007KT	KY50VB10M-TP5 5*11.5	
FB902	071G 55 9 T	FERRITE BEAD	
FB905	071G 55 9 T	FERRITE BEAD	
FB904	071G 55 9 T	FERRITE BEAD	
F901	084G 55 4	FUSE 382-5A 250V WICKMANN	

ZD931	093G 3916652T	MTZJ15B (13.89-14.62)	
ZD932	093G 3917052T	MTZJ27B (24.97-26.26V)	
D933	093G 5250S52T	DIODE AU02Z-V1 SANKEN	
D937	093T1080 252T	diode sarso1-v1 sanken	
	715T2804 2	POWER PCB	
	Q51G 6 4509	GLUE_RTV	
	040T 457624 1B	CPU LABEL	
	040T 45762412B	CBPC LABEL	
CN601	033G3278 4	4P PLUG B4B-XHA/JST	
CN403	033G8027 30 H	WAFER 30P 2.0MM RIGHT ANGLE	
CN701	033T327812D	WAFER 12P PLUG	
CN404	033T380213B Y	CONNECTOR	
C634	067G215S1024KV	EC 105°C CAP 1000UF M 25V	
CN605	088G 30211K	PHONE JACK 5PIN	
CN202	088T 78 13A37 YG	RCA JACK 1*2 W/R V/A RCA-276D-01	
CN203	088T 78 V6 C	RCA JACK 2*3 VERTICAL TYPE	
CN604	088T 30252C	PHONE JACK 3.5mm 3p V/A GREEN	
CN204	088T 35315FVSD	D-SUB 15PIN VERTICAL CONNECTOR	
CN603	088T 359 5 JT	FIBER-OPTIC 3P V/T JST1227	
CN201	088T100Z 5A CL	5 PIN MINI DIN JACK	
X402	093G 2245B J1	XTL NXS24.000AC12F-KAB3 12pf 30ppm	
X401	093T 2262B J	CRYSTAL NXS25.000 AC 20PF HC-49/US NSK	
TU202	094TNTAT MA 7M	TUNER NTSC+ATSC ENV56R01D8F	
C640	064G701J4740AT	0.47uF 50V	
C659	064G701J4740AT	0.47uF 50V	
C733	067G 2046812KT	CS CAP 680uF 10V 8*11 mm	
C728	067G 2046812KT	CS CAP 680uF 10V 8*11 mm	
C727	067G 2046812KT	CS CAP 680uF 10V 8*11 mm	
C719	067G 2046812KT	CS CAP 680uF 10V 8*11 mm	
C716	067G 2046812KT	CS CAP 680uF 10V 8*11 mm	
C710	067G 2046812KT	CS CAP 680uF 10V 8*11 mm	
C245	067G 2046812KT	CS CAP 680uF 10V 8*11 mm	
C4C3	067G 305100 3T	10UF 16V	
C603	067G 305100 3T	10UF 16V	
C605	067G 305100 3T	10UF 16V	
C608	067G 305100 3T	10UF 16V	
C610	067G 305100 3T	10UF 16V	
C611	067G 305100 3T	10UF 16V	
C614	067G 305100 3T	10UF 16V	
C618	067G 305100 3T	10UF 16V	
C619	067G 305100 3T	10UF 16V	
C620	067G 305100 3T	10UF 16V	
C743	067G 305100 3T	10UF 16V	
C744	067G 305100 3T	10UF 16V	
C627	067G 305220 4T	105°C 22UF, +-20% 25V	
C737	067G 305220 4T	105°C 22UF, +-20% 25V	
C745	067G 305220 4T	105°C 22UF, +-20% 25V	
C615	067G 305470 3T	47UF +-20% 16V	
C646	067G 305471 1T	105°C RADIAL E-CAPACTOR 470uF 6.3V	
C645	067G 305471 1T	105°C RADIAL E-CAPACTOR 470uF 6.3V	
C448	067G215B221 4T	105°C RADIAL E-CAPACTOR 220uF 25V	

C752	067G215B221 4T	105°C RADIAL E-CAPACTOR 220uF 25V	
C755	067G215B221 4T	105°C RADIAL E-CAPACTOR 220uF 25V	
L601	073G 259901 T	CHOKE 22uH 10% TSL0808RA-220K1R7	
L602	073G 259901 T	CHOKE 22uH 10% TSL0808RA-220K1R7	
L603	073G 259901 T	CHOKE 22uH 10% TSL0808RA-220K1R7	
L604	073G 259901 T	CHOKE 22uH 10% TSL0808RA-220K1R7	
FL701	053T 43 1	FILTER BULLWILL	
FL702	053T 43 1	FILTER BULLWILL	
U702	056G 379 92	IC G5627F11U SOP-8(FD)	
U705	056G 379 92	IC G5627F11U SOP-8(FD)	
U709	056G 563 56	AP1084D18LA TO-252-3L	
U704	056G 563 75	G1084-33T43UF TO-252	
U407	056G 563135	IC G952T24Uf SOT-89	
U708	056G 585 9	IC AP1117E50LA ANACHIP	
U405	056G 585 10	IC AP1117ELA-ADJ	
U706	056G 585 4A	IC AP1117E33L-13	
U406	056G 615 67	IC NT5TU32M16CG-25C 512MB BGA-84	
U602	056G 647 23	IC WM8594SEFT/RV TQFP-48	
U502	056G 662 14	IC TPD12S520DBTR TSSOP-38	
U503	056G 662 14	IC TPD12S520DBTR TSSOP-38	
U409	056G1125701 X	IC MCU RTD2120L-LF REALTEK	
U202	056G1133 34	M24C02-WMN6TP	
U402	056G1133103	IC M25P32-VMF6P 32M s0-16	
U403	056G113353A	IC M24C32-WMN6T SO-8 ST	
U203	056G4LVCG17 TI	IC SN74LVC1G17DBVR STO-23	
U204	056G4LVCG17 TI	IC SN74LVC1G17DBVR STO-23	
U707	056T 133 23 R	BA17809FP-E2	
U601	056T 593 31	IC STA559BW13TR PowerSSO36	
U401	056T1126 32	IC ZR39770BGCF BGA-632	
Q408	057G 417512	MMBT3906	
Q409	057G 417512	MMBT3906	
Q407	057G 417512	MMBT3906	
Q401	057G 763 3B	AM9435P.T1-PF SO-8	
Q705	057G 763 3B	AM9435P.T1-PF SO-8	
Q703	057G 763 3B	AM9435P.T1-PF SO-8	
Q402	057G 765 1	2SC2412K	
Q403	057G 765 1	2SC2412K	
Q404	057G 765 1	2SC2412K	
Q410	057G 765 1	2SC2412K	
Q411	057G 765 1	2SC2412K	
Q602	057G 765 1	2SC2412K	
Q704	057G 765 1	2SC2412K	
Q706	057G 765 1	2SC2412K	
R727	061G0603000	RST CHIP MAX 0R05 1/10W	
R704	061G0603000	RST CHIP MAX 0R05 1/10W	
R653	061G0603000	RST CHIP MAX 0R05 1/10W	
R651	061G0603000	RST CHIP MAX 0R05 1/10W	
R649	061G0603000	RST CHIP MAX 0R05 1/10W	
R634	061G0603000	RST CHIP MAX 0R05 1/10W	
R4G6	061G0603000	RST CHIP MAX 0R05 1/10W	
R4F8	061G0603000	RST CHIP MAX 0R05 1/10W	

R4B1	061G0603000	RST CHIP MAX 0R05 1/10W	
R451	061G0603000	RST CHIP MAX 0R05 1/10W	
R208	061G0603000	RST CHIP MAX 0R05 1/10W	
R701	061G0603100	RST CHIPR 10 OHM +-5% 1/10W	
R708	061G0603100	RST CHIPR 10 OHM +-5% 1/10W	
R262	061G0603101	RST CHIPR 100 OHM +-5% 1/10W	
R402	061G0603101	RST CHIPR 100 OHM +-5% 1/10W	
R454	061G0603101	RST CHIPR 100 OHM +-5% 1/10W	
R4A2	061G0603101	RST CHIPR 100 OHM +-5% 1/10W	
R452	061G0603101	RST CHIPR 100 OHM +-5% 1/10W	
R429	061G0603101	RST CHIPR 100 OHM +-5% 1/10W	
R411	061G0603101	RST CHIPR 100 OHM +-5% 1/10W	
R4A3	061G0603101	RST CHIPR 100 OHM +-5% 1/10W	
R4A4	061G0603101	RST CHIPR 100 OHM +-5% 1/10W	
R4A5	061G0603101	RST CHIPR 100 OHM +-5% 1/10W	
R4A6	061G0603101	RST CHIPR 100 OHM +-5% 1/10W	
R257	061G0603101	RST CHIPR 100 OHM +-5% 1/10W	
R635	061G0603101	RST CHIPR 100 OHM +-5% 1/10W	
R628	061G0603101	RST CHIPR 100 OHM +-5% 1/10W	
R4G3	061G0603101	RST CHIPR 100 OHM +-5% 1/10W	
R4F9	061G0603101	RST CHIPR 100 OHM +-5% 1/10W	
R4E7	061G0603101	RST CHIPR 100 OHM +-5% 1/10W	
R4C6	061G0603101	RST CHIPR 100 OHM +-5% 1/10W	
R4C3	061G0603101	RST CHIPR 100 OHM +-5% 1/10W	
R4A8	061G0603101	RST CHIPR 100 OHM +-5% 1/10W	
R4A7	061G0603101	RST CHIPR 100 OHM +-5% 1/10W	
R462	061G0603102	RST CHIPR 1K OHM +-5% 1/10W	
R406	061G0603102	RST CHIPR 1K OHM +-5% 1/10W	
R405	061G0603102	RST CHIPR 1K OHM +-5% 1/10W	
R403	061G0603102	RST CHIPR 1K OHM +-5% 1/10W	
R283	061G0603102	RST CHIPR 1K OHM +-5% 1/10W	
R259	061G0603102	RST CHIPR 1K OHM +-5% 1/10W	
R255	061G0603102	RST CHIPR 1K OHM +-5% 1/10W	
R484	061G0603102	RST CHIPR 1K OHM +-5% 1/10W	
R508	061G0603102	RST CHIPR 1K OHM +-5% 1/10W	
R516	061G0603102	RST CHIPR 1K OHM +-5% 1/10W	
R4D3	061G0603102	RST CHIPR 1K OHM +-5% 1/10W	
R4D6	061G0603102	RST CHIPR 1K OHM +-5% 1/10W	
R4H3	061G0603102	RST CHIPR 1K OHM +-5% 1/10W	
R4H6	061G0603102	RST CHIPR 1K OHM +-5% 1/10W	
R729	061G0603102	RST CHIPR 1K OHM +-5% 1/10W	
R522	061G0603103	RST CHIPR 10 KOHM +-5% 1/10W	
R510	061G0603103	RST CHIPR 10 KOHM +-5% 1/10W	
R4H1	061G0603103	RST CHIPR 10 KOHM +-5% 1/10W	
R4G7	061G0603103	RST CHIPR 10 KOHM +-5% 1/10W	
R4C5	061G0603103	RST CHIPR 10 KOHM +-5% 1/10W	
R4C4	061G0603103	RST CHIPR 10 KOHM +-5% 1/10W	
R4B7	061G0603103	RST CHIPR 10 KOHM +-5% 1/10W	
R4B6	061G0603103	RST CHIPR 10 KOHM +-5% 1/10W	
R4B5	061G0603103	RST CHIPR 10 KOHM +-5% 1/10W	
R4A1	061G0603103	RST CHIPR 10 KOHM +-5% 1/10W	

R499	061G0603103	RST CHIPR 10 KOHM +-5% 1/10W	
R498	061G0603103	RST CHIPR 10 KOHM +-5% 1/10W	
R497	061G0603103	RST CHIPR 10 KOHM +-5% 1/10W	
R496	061G0603103	RST CHIPR 10 KOHM +-5% 1/10W	
R495	061G0603103	RST CHIPR 10 KOHM +-5% 1/10W	
R494	061G0603103	RST CHIPR 10 KOHM +-5% 1/10W	
R424	061G0603103	RST CHIPR 10 KOHM +-5% 1/10W	
R278	061G0603103	RST CHIPR 10 KOHM +-5% 1/10W	
R614	061G0603103	RST CHIPR 10 KOHM +-5% 1/10W	
R633	061G0603103	RST CHIPR 10 KOHM +-5% 1/10W	
R655	061G0603103	RST CHIPR 10 KOHM +-5% 1/10W	
R658	061G0603103	RST CHIPR 10 KOHM +-5% 1/10W	
R662	061G0603103	RST CHIPR 10 KOHM +-5% 1/10W	
R673	061G0603103	RST CHIPR 10 KOHM +-5% 1/10W	
ZD221	061G0603103	RST CHIPR 10 KOHM +-5% 1/10W	
R725	061G0603104	RST CHIPR 100 KOHM +-5% 1/10W	
R719	061G0603104	RST CHIPR 100 KOHM +-5% 1/10W	
R428	061G0603105	RST CHIPR 1M OHM +-5% 1/10W	
R445	061G0603120 0F	RST CHIPR 120 OHM +-1% 1/10W	
R713	061G06031502FF	RST CHIPR 15KOHM +-1% 1/10W FENGHUA	
R705	061G06031502FF	RST CHIPR 15KOHM +-1% 1/10W FENGHUA	
R4D1	061G0603152	RST CHIPR 1.5 KOHM +-5% 1/10W	
R4C9	061G0603152	RST CHIPR 1.5 KOHM +-5% 1/10W	
R444	061G0603200 0F	RST CHIPR 200 OHM +-1% 1/10W	
R4D9	061G0603201	RST CHIPR 200 OHM +-5% 1/10W	
R717	061G0603204	RST CHIPR 200 KOHM +-5% 1/10W	
R617	061G0603220	RST CHIPR 22 OHM +-5% 1/10W	
R616	061G0603220	RST CHIPR 22 OHM +-5% 1/10W	
R615	061G0603220	RST CHIPR 22 OHM +-5% 1/10W	
R612	061G0603220	RST CHIPR 22 OHM +-5% 1/10W	
R611	061G0603220	RST CHIPR 22 OHM +-5% 1/10W	
R4G4	061G0603220	RST CHIPR 22 OHM +-5% 1/10W	
R4G2	061G0603220	RST CHIPR 22 OHM +-5% 1/10W	
R4G1	061G0603220	RST CHIPR 22 OHM +-5% 1/10W	
R408	061G0603220	RST CHIPR 22 OHM +-5% 1/10W	
R277	061G0603220	RST CHIPR 22 OHM +-5% 1/10W	
R276	061G0603220	RST CHIPR 22 OHM +-5% 1/10W	
R275	061G0603220	RST CHIPR 22 OHM +-5% 1/10W	
R274	061G0603220	RST CHIPR 22 OHM +-5% 1/10W	
R618	061G0603220	RST CHIPR 22 OHM +-5% 1/10W	
R6A7	061G0603220	RST CHIPR 22 OHM +-5% 1/10W	
R6A6	061G0603220	RST CHIPR 22 OHM +-5% 1/10W	
R669	061G0603220	RST CHIPR 22 OHM +-5% 1/10W	
R668	061G0603220	RST CHIPR 22 OHM +-5% 1/10W	
R648	061G0603220	RST CHIPR 22 OHM +-5% 1/10W	
R647	061G0603220	RST CHIPR 22 OHM +-5% 1/10W	
R646	061G0603220	RST CHIPR 22 OHM +-5% 1/10W	
R645	061G0603220	RST CHIPR 22 OHM +-5% 1/10W	
R623	061G0603220	RST CHIPR 22 OHM +-5% 1/10W	
R622	061G0603220	RST CHIPR 22 OHM +-5% 1/10W	
R621	061G0603220	RST CHIPR 22 OHM +-5% 1/10W	

R620	061G0603220	RST CHIPR 22 OHM +-5% 1/10W	
R619	061G0603220	RST CHIPR 22 OHM +-5% 1/10W	
R211	061G0603222	RST CHIPR 2.2 KOHM +-5% 1/10W	
R266	061G0603222	RST CHIPR 2.2 KOHM +-5% 1/10W	
R267	061G0603222	RST CHIPR 2.2 KOHM +-5% 1/10W	
R269	061G0603222	RST CHIPR 2.2 KOHM +-5% 1/10W	
R272	061G0603222	RST CHIPR 2.2 KOHM +-5% 1/10W	
R4B4	061G0603222	RST CHIPR 2.2 KOHM +-5% 1/10W	
R515	061G0603222	RST CHIPR 2.2 KOHM +-5% 1/10W	
R517	061G0603222	RST CHIPR 2.2 KOHM +-5% 1/10W	
R642	061G0603222	RST CHIPR 2.2 KOHM +-5% 1/10W	
R724	061G0603223	RST CHIPR 22 KOHM +-5% 1/10W	
R489	061G0603223	RST CHIPR 22 KOHM +-5% 1/10W	
R714	061G0603300 2F	RST CHIPR 30 KOHM +-1% 1/10W	
R270	061G0603301	RST CHIPR 300 OHM +-5% 1/10W	
R273	061G0603301	RST CHIPR 300 OHM +-5% 1/10W	
R254	061G0603330	RST CHIPR 33 OHM +-5% 1/10W	
R449	061G0603332	RST CHIPR 3.3 KOHM +-5% 1/10W	
R637	061G0603339	RST CHIPR 3.3 OHM +-5% 1/10W	
R650	061G0603339	RST CHIPR 3.3 OHM +-5% 1/10W	
R521	061G0603390 0F	RST CHIPR 390 OHM +-1% 1/10W	
R511	061G0603390 0F	RST CHIPR 390 OHM +-1% 1/10W	
R203	061G0603390 1F	RST CHIPR 3.9 KOHM +-1% 1/10W	
R410	061G0603470	RST CHIPR 47 OHM +-5% 1/10W	
R421	061G0603470	RST CHIPR 47 OHM +-5% 1/10W	
R422	061G0603470	RST CHIPR 47 OHM +-5% 1/10W	
R423	061G0603470	RST CHIPR 47 OHM +-5% 1/10W	
R703	061G0603470 2F	RST CHIPR 47 KOHM +-1% 1/10W	
R210	061G0603472	RST CHIPR 4.7K OHM +-5% 1/10W	
R260	061G0603472	RST CHIPR 4.7K OHM +-5% 1/10W	
R261	061G0603472	RST CHIPR 4.7K OHM +-5% 1/10W	
R4E1	061G0603472	RST CHIPR 4.7K OHM +-5% 1/10W	
R4B2	061G0603472	RST CHIPR 4.7K OHM +-5% 1/10W	
R4A9	061G0603472	RST CHIPR 4.7K OHM +-5% 1/10W	
R442	061G0603472	RST CHIPR 4.7K OHM +-5% 1/10W	
R441	061G0603472	RST CHIPR 4.7K OHM +-5% 1/10W	
R431	061G0603472	RST CHIPR 4.7K OHM +-5% 1/10W	
R430	061G0603472	RST CHIPR 4.7K OHM +-5% 1/10W	
R427	061G0603472	RST CHIPR 4.7K OHM +-5% 1/10W	
R426	061G0603472	RST CHIPR 4.7K OHM +-5% 1/10W	
R425	061G0603472	RST CHIPR 4.7K OHM +-5% 1/10W	
R419	061G0603472	RST CHIPR 4.7K OHM +-5% 1/10W	
R418	061G0603472	RST CHIPR 4.7K OHM +-5% 1/10W	
R417	061G0603472	RST CHIPR 4.7K OHM +-5% 1/10W	
R416	061G0603472	RST CHIPR 4.7K OHM +-5% 1/10W	
R4E4	061G0603472	RST CHIPR 4.7K OHM +-5% 1/10W	
R401	061G0603472	RST CHIPR 4.7K OHM +-5% 1/10W	
R404	061G0603472	RST CHIPR 4.7K OHM +-5% 1/10W	
R407	061G0603472	RST CHIPR 4.7K OHM +-5% 1/10W	
R409	061G0603472	RST CHIPR 4.7K OHM +-5% 1/10W	
R414	061G0603472	RST CHIPR 4.7K OHM +-5% 1/10W	

R415	061G0603472	RST CHIPR 4.7K OHM +-5% 1/10W	
R631	061G0603472	RST CHIPR 4.7K OHM +-5% 1/10W	
R630	061G0603472	RST CHIPR 4.7K OHM +-5% 1/10W	
R629	061G0603472	RST CHIPR 4.7K OHM +-5% 1/10W	
R627	061G0603472	RST CHIPR 4.7K OHM +-5% 1/10W	
R626	061G0603472	RST CHIPR 4.7K OHM +-5% 1/10W	
R624	061G0603472	RST CHIPR 4.7K OHM +-5% 1/10W	
R520	061G0603472	RST CHIPR 4.7K OHM +-5% 1/10W	
R509	061G0603472	RST CHIPR 4.7K OHM +-5% 1/10W	
R233	061G0603473	RST CHIPR 47 KOHM +-5% 1/10W	
R234	061G0603473	RST CHIPR 47 KOHM +-5% 1/10W	
R245	061G0603473	RST CHIPR 47 KOHM +-5% 1/10W	
R246	061G0603473	RST CHIPR 47 KOHM +-5% 1/10W	
R488	061G0603473	RST CHIPR 47 KOHM +-5% 1/10W	
R491	061G0603473	RST CHIPR 47 KOHM +-5% 1/10W	
R4G9	061G0603473	RST CHIPR 47 KOHM +-5% 1/10W	
R660	061G0603473	RST CHIPR 47 KOHM +-5% 1/10W	
R661	061G0603473	RST CHIPR 47 KOHM +-5% 1/10W	
R663	061G0603473	RST CHIPR 47 KOHM +-5% 1/10W	
R664	061G0603473	RST CHIPR 47 KOHM +-5% 1/10W	
R715	061G0603473	RST CHIPR 47 KOHM +-5% 1/10W	
R723	061G0603473	RST CHIPR 47 KOHM +-5% 1/10W	
R459	061G0603510 0F	RST CHIPR 510OHM +-1% 1/10W	
R202	061G0603512	RST CHIPR 5.1 KOHM +-5% 1/10W	
R280	061G0603512	RST CHIPR 5.1 KOHM +-5% 1/10W	
R281	061G0603512	RST CHIPR 5.1 KOHM +-5% 1/10W	
R450	061G0603620 2F	RST CHIPR 62 KOHM +-1% 1/10W	
R228	061G0603750 9F	RST CHIPR 75 OHM +-1% 1/10W	
R244	061G0603750 9F	RST CHIPR 75 OHM +-1% 1/10W	
R251	061G0603750 9F	RST CHIPR 75 OHM +-1% 1/10W	
R448	061G0603750 9F	RST CHIPR 75 OHM +-1% 1/10W	
R252	061G0603750 9F	RST CHIPR 75 OHM +-1% 1/10W	
R250	061G0603750 9F	RST CHIPR 75 OHM +-1% 1/10W	
R243	061G0603750 9F	RST CHIPR 75 OHM +-1% 1/10W	
R229	061G0603750 9F	RST CHIPR 75 OHM +-1% 1/10W	
R232	061G0603750 9F	RST CHIPR 75 OHM +-1% 1/10W	
R242	061G0603750 9F	RST CHIPR 75 OHM +-1% 1/10W	
R502	061G0603752	RST CHIPR 7.5 KOHM +-5% 1/10W	
R507	061G0603752	RST CHIPR 7.5 KOHM +-5% 1/10W	
R513	061G0603752	RST CHIPR 7.5 KOHM +-5% 1/10W	
R506	061G0603752	RST CHIPR 7.5 KOHM +-5% 1/10W	
R503	061G0603752	RST CHIPR 7.5 KOHM +-5% 1/10W	
R514	061G0603752	RST CHIPR 7.5 KOHM +-5% 1/10W	
R519	061G0603752	RST CHIPR 7.5 KOHM +-5% 1/10W	
R518	061G0603752	RST CHIPR 7.5 KOHM +-5% 1/10W	
R483	061G0603821	RST CHIPR 820 OHM +-5% 1/10W	
R4E5	061G0603822	RST CHIPR 8.2 KOHM +-5% 1/10W	
R447	061G0603845 0F	RST CHIP 845R 1/10W 1%	
R446	061G0603845 0F	RST CHIP 845R 1/10W 1%	
R728	061G0805152	RST CHIPR 1.5 KOHM +-5% 1/8W	
R4H4	061G0805152	RST CHIPR 1.5 KOHM +-5% 1/8W	

R4G5	061G1206000	RST CHIP MAX 0R05 1/4W	
R486	061G1206000	RST CHIP MAX 0R05 1/4W	
R670	061G1206220	RST CHIPR 22 OHM +-5% 1/4W	
R639	061G1206220	RST CHIPR 22 OHM +-5% 1/4W	
R672	061G1206629	RST CHIP 6R2 1/4W 5%	
R716	061G1206629	RST CHIP 6R2 1/4W 5%	
R644	061G1206629	RST CHIP 6R2 1/4W 5%	
R671	061G1206629	RST CHIP 6R2 1/4W 5%	
R640	061G1206629	RST CHIP 6R2 1/4W 5%	
R237	061T0603348 0F	RST CHIPR 348 OHM +-1% 1/10W	
R458	061T0603619 9F	RST CHIPR 61.9 OHM +-1% 1/10W	
R457	061T0603619 9F	RST CHIPR 61.9 OHM +-1% 1/10W	
R453	061T0603910	RST CHIPR 91 OHM +-5% 1/10W	
C732	065G0402102 32	1000PF +-10% 50V X7R	
C715	065G0402102 32	1000PF +-10% 50V X7R	
C4B9	065G0402102 32	1000PF +-10% 50V X7R	
C454	065G0402102 32	1000PF +-10% 50V X7R	
C410	065G0402102 32	1000PF +-10% 50V X7R	
C408	065G0402102 32	1000PF +-10% 50V X7R	
C281	065G0402102 32	1000PF +-10% 50V X7R	
C275	065G0402102 32	1000PF +-10% 50V X7R	
C223	065G0402102 32	1000PF +-10% 50V X7R	
C217	065G0402102 32	1000PF +-10% 50V X7R	
C4D8	065G0402103 22	CHIP 0.01UF 25V X7R	
C4B8	065G0402103 22	CHIP 0.01UF 25V X7R	
C453	065G0402103 22	CHIP 0.01UF 25V X7R	
C411	065G0402103 22	CHIP 0.01UF 25V X7R	
C409	065G0402103 22	CHIP 0.01UF 25V X7R	
C230	065G0402103 22	CHIP 0.01UF 25V X7R	
C209	065G0402103 22	CHIP 0.01UF 25V X7R	
C498	065G0402104 12	CAP CHIP 0402 0.1UF 16V X7R	
C497	065G0402104 12	CAP CHIP 0402 0.1UF 16V X7R	
C496	065G0402104 12	CAP CHIP 0402 0.1UF 16V X7R	
C495	065G0402104 12	CAP CHIP 0402 0.1UF 16V X7R	
C478	065G0402104 12	CAP CHIP 0402 0.1UF 16V X7R	
C477	065G0402104 12	CAP CHIP 0402 0.1UF 16V X7R	
C476	065G0402104 12	CAP CHIP 0402 0.1UF 16V X7R	
C475	065G0402104 12	CAP CHIP 0402 0.1UF 16V X7R	
C474	065G0402104 12	CAP CHIP 0402 0.1UF 16V X7R	
C456	065G0402104 12	CAP CHIP 0402 0.1UF 16V X7R	
C458	065G0402104 12	CAP CHIP 0402 0.1UF 16V X7R	
C459	065G0402104 12	CAP CHIP 0402 0.1UF 16V X7R	
C460	065G0402104 12	CAP CHIP 0402 0.1UF 16V X7R	
C463	065G0402104 12	CAP CHIP 0402 0.1UF 16V X7R	
C464	065G0402104 12	CAP CHIP 0402 0.1UF 16V X7R	
C465	065G0402104 12	CAP CHIP 0402 0.1UF 16V X7R	
C466	065G0402104 12	CAP CHIP 0402 0.1UF 16V X7R	
C467	065G0402104 12	CAP CHIP 0402 0.1UF 16V X7R	
C468	065G0402104 12	CAP CHIP 0402 0.1UF 16V X7R	
C469	065G0402104 12	CAP CHIP 0402 0.1UF 16V X7R	
C470	065G0402104 12	CAP CHIP 0402 0.1UF 16V X7R	

C471	065G0402104 12	CAP CHIP 0402 0.1UF 16V X7R	
C472	065G0402104 12	CAP CHIP 0402 0.1UF 16V X7R	
C473	065G0402104 12	CAP CHIP 0402 0.1UF 16V X7R	
C494	065G0402104 12	CAP CHIP 0402 0.1UF 16V X7R	
C4D2	065G0402104 12	CAP CHIP 0402 0.1UF 16V X7R	
C4D5	065G0402104 12	CAP CHIP 0402 0.1UF 16V X7R	
C4D6	065G0402104 12	CAP CHIP 0402 0.1UF 16V X7R	
C4D7	065G0402104 12	CAP CHIP 0402 0.1UF 16V X7R	
C4E6	065G0402104 12	CAP CHIP 0402 0.1UF 16V X7R	
C4E7	065G0402104 12	CAP CHIP 0402 0.1UF 16V X7R	
C4E8	065G0402104 12	CAP CHIP 0402 0.1UF 16V X7R	
C4F1	065G0402104 12	CAP CHIP 0402 0.1UF 16V X7R	
C481	065G0402104 12	CAP CHIP 0402 0.1UF 16V X7R	
C482	065G0402104 12	CAP CHIP 0402 0.1UF 16V X7R	
C483	065G0402104 12	CAP CHIP 0402 0.1UF 16V X7R	
C484	065G0402104 12	CAP CHIP 0402 0.1UF 16V X7R	
C485	065G0402104 12	CAP CHIP 0402 0.1UF 16V X7R	
C486	065G0402104 12	CAP CHIP 0402 0.1UF 16V X7R	
C487	065G0402104 12	CAP CHIP 0402 0.1UF 16V X7R	
C4A8	065G0402104 12	CAP CHIP 0402 0.1UF 16V X7R	
C492	065G0402104 12	CAP CHIP 0402 0.1UF 16V X7R	
C491	065G0402104 12	CAP CHIP 0402 0.1UF 16V X7R	
C490	065G0402104 12	CAP CHIP 0402 0.1UF 16V X7R	
C489	065G0402104 12	CAP CHIP 0402 0.1UF 16V X7R	
C488	065G0402104 12	CAP CHIP 0402 0.1UF 16V X7R	
C499	065G0402104 12	CAP CHIP 0402 0.1UF 16V X7R	
C4A3	065G0402104 12	CAP CHIP 0402 0.1UF 16V X7R	
C4A2	065G0402104 12	CAP CHIP 0402 0.1UF 16V X7R	
C4A1	065G0402104 12	CAP CHIP 0402 0.1UF 16V X7R	
C4G6	065G0402104 12	CAP CHIP 0402 0.1UF 16V X7R	
C4G7	065G0402104 12	CAP CHIP 0402 0.1UF 16V X7R	
C4H4	065G0402104 12	CAP CHIP 0402 0.1UF 16V X7R	
C4A5	065G0402104 12	CAP CHIP 0402 0.1UF 16V X7R	
C4A4	065G0402104 12	CAP CHIP 0402 0.1UF 16V X7R	
C4A6	065G0402104 12	CAP CHIP 0402 0.1UF 16V X7R	
C204	065G0402104 12	CAP CHIP 0402 0.1UF 16V X7R	
C207	065G0402104 12	CAP CHIP 0402 0.1UF 16V X7R	
C208	065G0402104 12	CAP CHIP 0402 0.1UF 16V X7R	
C211	065G0402104 12	CAP CHIP 0402 0.1UF 16V X7R	
C212	065G0402104 12	CAP CHIP 0402 0.1UF 16V X7R	
C221	065G0402104 12	CAP CHIP 0402 0.1UF 16V X7R	
C222	065G0402104 12	CAP CHIP 0402 0.1UF 16V X7R	
C225	065G0402104 12	CAP CHIP 0402 0.1UF 16V X7R	
C226	065G0402104 12	CAP CHIP 0402 0.1UF 16V X7R	
C234	065G0402104 12	CAP CHIP 0402 0.1UF 16V X7R	
C455	065G0402104 12	CAP CHIP 0402 0.1UF 16V X7R	
C414	065G0402104 12	CAP CHIP 0402 0.1UF 16V X7R	
C406	065G0402104 12	CAP CHIP 0402 0.1UF 16V X7R	
C291	065G0402104 12	CAP CHIP 0402 0.1UF 16V X7R	
C280	065G0402104 12	CAP CHIP 0402 0.1UF 16V X7R	
C279	065G0402104 12	CAP CHIP 0402 0.1UF 16V X7R	

C278	065G0402104 12	CAP CHIP 0402 0.1UF 16V X7R	
C260	065G0402104 12	CAP CHIP 0402 0.1UF 16V X7R	
C256	065G0402104 12	CAP CHIP 0402 0.1UF 16V X7R	
C255	065G0402104 12	CAP CHIP 0402 0.1UF 16V X7R	
C4E5	065G0402105 05	MLCC 0402 1μF 6.3V X5R	
C4E4	065G0402105 05	MLCC 0402 1μF 6.3V X5R	
C4E3	065G0402105 05	MLCC 0402 1μF 6.3V X5R	
C4D4	065G0402105 05	MLCC 0402 1μF 6.3V X5R	
C457	065G0402105 05	MLCC 0402 1μF 6.3V X5R	
C415	065G0402105 05	MLCC 0402 1μF 6.3V X5R	
C413	065G0402105 05	MLCC 0402 1μF 6.3V X5R	
C407	065G0402105 05	MLCC 0402 1μF 6.3V X5R	
C235	065G0402105 05	MLCC 0402 1μF 6.3V X5R	
C675	065G0603101 31	CER1 0603 NP0 50V 100P PM5 R	
C205	065G0603101 31	CER1 0603 NP0 50V 100P PM5 R	
C648	065G0603101 31	CER1 0603 NP0 50V 100P PM5 R	
C674	065G0603101 31	CER1 0603 NP0 50V 100P PM5 R	
C647	065G0603101 31	CER1 0603 NP0 50V 100P PM5 R	
C625	065G0603101 31	CER1 0603 NP0 50V 100P PM5 R	
C624	065G0603101 31	CER1 0603 NP0 50V 100P PM5 R	
C4F6	065G0603101 31	CER1 0603 NP0 50V 100P PM5 R	
C4F5	065G0603101 31	CER1 0603 NP0 50V 100P PM5 R	
C4C7	065G0603101 31	CER1 0603 NP0 50V 100P PM5 R	
C452	065G0603101 31	CER1 0603 NP0 50V 100P PM5 R	
C206	065G0603101 31	CER1 0603 NP0 50V 100P PM5 R	
C670	065G0603102 31	CHIP 1000PF 50V NPO	
C669	065G0603102 31	CHIP 1000PF 50V NPO	
C668	065G0603102 31	CHIP 1000PF 50V NPO	
C450	065G0603102 31	CHIP 1000PF 50V NPO	
C250	065G0603102 31	CHIP 1000PF 50V NPO	
C244	065G0603102 31	CHIP 1000PF 50V NPO	
C241	065G0603102 31	CHIP 1000PF 50V NPO	
C671	065G0603102 31	CHIP 1000PF 50V NPO	
C672	065G0603102 31	CHIP 1000PF 50V NPO	
C673	065G0603102 31	CHIP 1000PF 50V NPO	
C692	065G0603102 31	CHIP 1000PF 50V NPO	
C706	065G0603102 31	CHIP 1000PF 50V NPO	
C754	065G0603102 31	CHIP 1000PF 50V NPO	
C757	065G0603102 31	CHIP 1000PF 50V NPO	
C712	065G0603102 32	1000PF +-10% 50V X7R	
C722	065G0603104 12	CER2 0603 X7R 16V 100N P	
C4B6	065G0603104 32	CHIP 0.1UF 50V X7R	
C4B7	065G0603104 32	CHIP 0.1UF 50V X7R	
C4C4	065G0603104 32	CHIP 0.1UF 50V X7R	
C4F2	065G0603104 32	CHIP 0.1UF 50V X7R	
C4F3	065G0603104 32	CHIP 0.1UF 50V X7R	
C4F4	065G0603104 32	CHIP 0.1UF 50V X7R	
C4F7	065G0603104 32	CHIP 0.1UF 50V X7R	
C4F9	065G0603104 32	CHIP 0.1UF 50V X7R	
C4H3	065G0603104 32	CHIP 0.1UF 50V X7R	
C501	065G0603104 32	CHIP 0.1UF 50V X7R	

C502	065G0603104 32	CHIP 0.1UF 50V X7R	
C505	065G0603104 32	CHIP 0.1UF 50V X7R	
C506	065G0603104 32	CHIP 0.1UF 50V X7R	
C507	065G0603104 32	CHIP 0.1UF 50V X7R	
C508	065G0603104 32	CHIP 0.1UF 50V X7R	
C509	065G0603104 32	CHIP 0.1UF 50V X7R	
C510	065G0603104 32	CHIP 0.1UF 50V X7R	
C601	065G0603104 32	CHIP 0.1UF 50V X7R	
C604	065G0603104 32	CHIP 0.1UF 50V X7R	
C666	065G0603104 32	CHIP 0.1UF 50V X7R	
C664	065G0603104 32	CHIP 0.1UF 50V X7R	
C662	065G0603104 32	CHIP 0.1UF 50V X7R	
C658	065G0603104 32	CHIP 0.1UF 50V X7R	
C655	065G0603104 32	CHIP 0.1UF 50V X7R	
C653	065G0603104 32	CHIP 0.1UF 50V X7R	
C652	065G0603104 32	CHIP 0.1UF 50V X7R	
C651	065G0603104 32	CHIP 0.1UF 50V X7R	
C643	065G0603104 32	CHIP 0.1UF 50V X7R	
C642	065G0603104 32	CHIP 0.1UF 50V X7R	
C638	065G0603104 32	CHIP 0.1UF 50V X7R	
C636	065G0603104 32	CHIP 0.1UF 50V X7R	
C633	065G0603104 32	CHIP 0.1UF 50V X7R	
C630	065G0603104 32	CHIP 0.1UF 50V X7R	
C626	065G0603104 32	CHIP 0.1UF 50V X7R	
C617	065G0603104 32	CHIP 0.1UF 50V X7R	
C616	065G0603104 32	CHIP 0.1UF 50V X7R	
C609	065G0603104 32	CHIP 0.1UF 50V X7R	
C756	065G0603104 32	CHIP 0.1UF 50V X7R	
C753	065G0603104 32	CHIP 0.1UF 50V X7R	
C746	065G0603104 32	CHIP 0.1UF 50V X7R	
C742	065G0603104 32	CHIP 0.1UF 50V X7R	
C740	065G0603104 32	CHIP 0.1UF 50V X7R	
C735	065G0603104 32	CHIP 0.1UF 50V X7R	
C734	065G0603104 32	CHIP 0.1UF 50V X7R	
C731	065G0603104 32	CHIP 0.1UF 50V X7R	
C730	065G0603104 32	CHIP 0.1UF 50V X7R	
C729	065G0603104 32	CHIP 0.1UF 50V X7R	
C721	065G0603104 32	CHIP 0.1UF 50V X7R	
C720	065G0603104 32	CHIP 0.1UF 50V X7R	
C717	065G0603104 32	CHIP 0.1UF 50V X7R	
C714	065G0603104 32	CHIP 0.1UF 50V X7R	
C711	065G0603104 32	CHIP 0.1UF 50V X7R	
C705	065G0603104 32	CHIP 0.1UF 50V X7R	
C691	065G0603104 32	CHIP 0.1UF 50V X7R	
C667	065G0603104 32	CHIP 0.1UF 50V X7R	
C240	065G0603104 32	CHIP 0.1UF 50V X7R	
C243	065G0603104 32	CHIP 0.1UF 50V X7R	
C249	065G0603104 32	CHIP 0.1UF 50V X7R	
C289	065G0603104 32	CHIP 0.1UF 50V X7R	
C403	065G0603104 32	CHIP 0.1UF 50V X7R	
C426	065G0603104 32	CHIP 0.1UF 50V X7R	

C427	065G0603104 32	CHIP 0.1UF 50V X7R	
C428	065G0603104 32	CHIP 0.1UF 50V X7R	
C429	065G0603104 32	CHIP 0.1UF 50V X7R	
C431	065G0603104 32	CHIP 0.1UF 50V X7R	
C4B5	065G0603104 32	CHIP 0.1UF 50V X7R	
C4B4	065G0603104 32	CHIP 0.1UF 50V X7R	
C4B3	065G0603104 32	CHIP 0.1UF 50V X7R	
C4B2	065G0603104 32	CHIP 0.1UF 50V X7R	
C4B1	065G0603104 32	CHIP 0.1UF 50V X7R	
C4A9	065G0603104 32	CHIP 0.1UF 50V X7R	
C461	065G0603104 32	CHIP 0.1UF 50V X7R	
C449	065G0603104 32	CHIP 0.1UF 50V X7R	
C432	065G0603104 32	CHIP 0.1UF 50V X7R	
C632	065G0603105 12	CHIP 1UF 16VX7R 0603	
C635	065G0603105 12	CHIP 1UF 16VX7R 0603	
C425	065G0603105 17	1UF 16V Y5V	
C430	065G0603105 17	1UF 16V Y5V	
C4D3	065G0603105 17	1UF 16V Y5V	
C4F8	065G0603105 17	1UF 16V Y5V	
C701	065G0603105 17	1UF 16V Y5V	
C702	065G0603105 17	1UF 16V Y5V	
C751	065G0603105 17	1UF 16V Y5V	
C749	065G0603105 17	1UF 16V Y5V	
C738	065G0603105 17	1UF 16V Y5V	
C736	065G0603105 17	1UF 16V Y5V	
C725	065G0603105 17	1UF 16V Y5V	
C724	065G0603105 17	1UF 16V Y5V	
C4C2	065G0603150 31	CHIP 15PF 50V NPO	
C247	065G0603152 32	1500PF +-10% 50V X7R 06	
C4C1	065G0603180 31	CAP CC 18PF 50V J NPO 0603	
C694	065G0603220 31	CER1 0603 NP0 50V 22P PM	
C693	065G0603220 31	CER1 0603 NP0 50V 22P PM	
C4H2	065G0603220 31	CER1 0603 NP0 50V 22P PM	
C4H1	065G0603220 31	CER1 0603 NP0 50V 22P PM	
C4G3	065G0603220 31	CER1 0603 NP0 50V 22P PM	
C4G1	065G0603220 31	CER1 0603 NP0 50V 22P PM	
C623	065G0603221 32	CHIP 220PF 50V X7R	
C622	065G0603221 32	CHIP 220PF 50V X7R	
C613	065G0603221 32	CHIP 220PF 50V X7R	
C612	065G0603221 32	CHIP 220PF 50V X7R	
C607	065G0603221 32	CHIP 220PF 50V X7R	
C606	065G0603221 32	CHIP 220PF 50V X7R	
C285	065G0603224 32	CHIP 0.22UF 50V X7R	
C402	065G0603224 32	CHIP 0.22UF 50V X7R	
C462	065G0603224 32	CHIP 0.22UF 50V X7R	
C739	065G0603224 32	CHIP 0.22UF 50V X7R	
C747	065G0603224 32	CHIP 0.22UF 50V X7R	
C748	065G0603224 32	CHIP 0.22UF 50V X7R	
C404	065G0603330 31 GP	33PF+-5% 50V NPO	
C405	065G0603330 31 GP	33PF+-5% 50V NPO	
C644	065G0603331 32	CHIP 330PF 50V X7R	

C660	065G0603331 32	CHIP 330PF 50V X7R	
C417	065G0603392 32	CHIP 3900PF 50V X7R	
C416	065G0603393 32	CHIP 0.039UF 50V X7R	
C649	065G0603472 32 GP	CHIP 4700PF 50V NPO	
C421	065G0603474 12	MLCC 0603 0.47UF K 16V X7R	
C246	065G0603561 31	CAP:CER 560PF 5%50V SMT 0603	
C220	065G0603820 31	0603 82PF +-5%, 50V NPO	
C4C8	065G1206106 15	CHIP 10UF 16V X5R	
C479	065G120610612K 3	CHIP 10uF 16V X7R 10%	
C493	065G120610612K 3	CHIP 10uF 16V X7R 10%	
C4A7	065G120610612K 3	CHIP 10uF 16V X7R 10%	
C480	065G120610612K 3	CHIP 10uF 16V X7R 10%	
C424	065G120610612K 3	CHIP 10uF 16V X7R 10%	
C629	065G1206475 22	4.7U/25V X7R	
C628	065G1206475 22	4.7U/25V X7R	
C420	065G1206475 22	4.7U/25V X7R	
C418	065G1206475 22	4.7U/25V X7R	
C231	065G1206475 22	4.7U/25V X7R	
C210	065G1206475 22	4.7U/25V X7R	
C631	065G1206475 22	4.7U/25V X7R	
C233	065T040210505K Y	CAP CHIP 0402 1UF 6V3 X5R +/-10%	
C274	065T0402224 A7	CAP 0402 0.22UF Z 10V	
C273	065T0402224 A7	CAP 0402 0.22UF Z 10V	
C272	065T0402224 A7	CAP 0402 0.22UF Z 10V	
C650	065T0603681 21	CHIP 680PF 25V NPO	
C419	065T1206226 A5	CHIP 22UF 10V X5R	
C4D1	065T1206226 A5	CHIP 22UF 10V X5R	
C4G5	065T1206226 A5	CHIP 22UF 10V X5R	
C4G9	065T1206226 A5	CHIP 22UF 10V X5R	
C726	065T1206226 A5	CHIP 22UF 10V X5R	
C758	065T1206226 A5	CHIP 22UF 10V X5R	
C759	065T1206226 A5	CHIP 22UF 10V X5R	
C760	065T1206226 A5	CHIP 22UF 10V X5R	
FB601	071G 56G301 EA	BEAD 300 OHM	
FB602	071G 56G301 EA	BEAD 300 OHM	
FB604	071G 56G301 EA	BEAD 300 OHM	
FB605	071G 56G301 EA	BEAD 300 OHM	
FB410	071G 59B121	TB160808B	
FB411	071G 59B121	TB160808B	
FB412	071G 59B121	TB160808B	
FB414	071G 59B121	TB160808B	
FB415	071G 59B121	TB160808B	
FB416	071G 59B121	TB160808B	
FB417	071G 59B121	TB160808B	
FB418	071G 59B121	TB160808B	
FB420	071G 59B121	TB160808B	
FB408	071G 59B121	TB160808B	
FB405	071G 59B121	TB160808B	
FB404	071G 59B121	TB160808B	
FB402	071G 59B121	TB160808B	
FB220	071G 59B121	TB160808B	

FB219	071G 59B121	TB160808B	
FB217	071G 59B121	TB160808B	
FB216	071G 59B121	TB160808B	
FB207	071G 59B121	TB160808B	
FB203	071G 59B601 EA	CHIP BEAD 600 OHM	
FB206	071G 59B601 EA	CHIP BEAD 600 OHM	
FB209	071G 59B601 EA	CHIP BEAD 600 OHM	
FB210	071G 59B601 EA	CHIP BEAD 600 OHM	
FB212	071G 59B601 EA	CHIP BEAD 600 OHM	
FB607	071G 59B601 EA	CHIP BEAD 600 OHM	
FB608	071G 59B601 EA	CHIP BEAD 600 OHM	
FB413	071G 59C121 B	FCM1608C-121T03 SMD	
FB213	071G 59K300 B	CHIP BEAD FCB1608KF-300T07 bullwill	
FB214	071G 59K300 B	CHIP BEAD FCB1608KF-300T07 bullwill	
FB215	071G 59K300 B	CHIP BEAD FCB1608KF-300T07 bullwill	
FB221	071G 59K300 B	CHIP BEAD FCB1608KF-300T07 bullwill	
FB222	071G 59K300 B	CHIP BEAD FCB1608KF-300T07 bullwill	
FB223	071G 59K300 B	CHIP BEAD FCB1608KF-300T07 bullwill	
FB224	071G 59K300 B	CHIP BEAD FCB1608KF-300T07 bullwill	
FB225	071G 59K300 B	CHIP BEAD FCB1608KF-300T07 bullwill	
FB226	071G 59K300 B	CHIP BEAD FCB1608KF-300T07 bullwill	
FB403	071T 59B121 J	CHIP BEAD 121 OHM	
FB401	071T 59B121 J	CHIP BEAD 121 OHM	
FB705	071T3216330 6Y	CHIP BEAD 1206 33ohm 6A	
FB704	071T3216330 6Y	CHIP BEAD 1206 33ohm 6A	
FB703	071T3216330 6Y	CHIP BEAD 1206 33ohm 6A	
FB701	071T3216330 6Y	CHIP BEAD 1206 33ohm 6A	
FB603	071T3216330 6Y	CHIP BEAD 1206 33ohm 6A	
L203	073G 8515810K	CHIP INDUCTOR 0.15uH 10% 0805	
L702	073G253S 46 B	SMD CHOKE TP0504-4R7M 4.7uH	
L701	073G253S 46 B	SMD CHOKE TP0504-4R7M 4.7uH	
L204	073T 57228	chip inductor 0805 0.22uH+-10% JKMT	
L202	073T 57228	chip inductor 0805 0.22uH+-10% JKMT	
CN502	088T 340 21 VD	HDMI HEADER 21P V/T	
CN501	088T 340 21 VD	HDMI HEADER 21P V/T	
ZD212	093G 60505	DIO SIG SM BAT54C(PHSE)R	
ZD217	093G 64 37 N	VPORT0603100KV05	
ZD216	093G 64 37 N	VPORT0603100KV05	
ZD218	093G 64 37 N	VPORT0603100KV05	
ZD219	093G 64 37 N	VPORT0603100KV05	
ZD220	093G 64 37 N	VPORT0603100KV05	
ZD223	093G 64 37 N	VPORT0603100KV05	
ZD224	093G 64 37 N	VPORT0603100KV05	
ZD403	093G 64 37 N	VPORT0603100KV05	
ZD404	093G 64 37 N	VPORT0603100KV05	
ZD601	093G 64 37 N	VPORT0603100KV05	
ZD602	093G 64 37 N	VPORT0603100KV05	
ZD603	093G 64 37 N	VPORT0603100KV05	
ZD604	093G 64 37 N	VPORT0603100KV05	
ZD605	093G 64 37 N	VPORT0603100KV05	
ZD208	093G 64 37 N	VPORT0603100KV05	

ZD210	093G 64 37 N	VPORT0603100KV05	
ZD201	093G 64 37 N	VPORT0603100KV05	
ZD204	093G 64 37 N	VPORT0603100KV05	
ZD205	093G 64 37 N	VPORT0603100KV05	
ZD203	093G 64 37 N	VPORT0603100KV05	
ZD202	093G 64 37 N	VPORT0603100KV05	
ZD207	093G 64 37 N	VPORT0603100KV05	
ZD209	093G 64 37 N	VPORT0603100KV05	
	093G 64 37 N	VPORT0603100KV05	
ZD213	093G 64 37 N	VPORT0603100KV05	
ZD214	093G 64 37 N	VPORT0603100KV05	
ZD215	093G 64 37 N	VPORT0603100KV05	
D401	093G 6432P	LL4148	
D404	093G 6432P	LL4148	
	715T2763 2	MAIN PCB	
	Q12T 408 9	THERMAL PAD	
	Q85T0078101 S	Shield	
	IRPF8QB3	IR BOARD	
CN01	033G3802 5B YH	CONNECTOR 5PIN 2.0PITCH	
U01	056T 627 33 1	IR 37.9KHZ KSM-603TM2E	
R01	061G0603153	RST CHIPR 15KOHM +-5% 1/10W	
C01	065G0603104 32	CHIP 0.1UF 50V X7R	
LED01	081G 14 24 EL	CHIP LED BLUE/DARK RED	
	715T3107 1	IR PCB	
	Q11T5027 1	LEAD-CLAMPER	
	Q15T0307103	bkt-pcb-holder-top	
	Q15T0308103	bkt-pcb-holder-btm	
	Q15T0309103	bkt-panel-support	
	Q15T0310101	bkt-vesa-top	
	Q15T0317101	bkt-smallpcb-holder	
	Q15T0371101	bkt-smallpcb-holder-s	
	Q35T0031 1A1P0200	TRIM_BEZEL	
	Q36T 600 18113	CLOTH_GRIDDING	
	Q36T 600 18114	CLOTH_GRIDDING	
	Q36T 600 37 12 GP	NONWOVEN FABRIC	
	Q40G000262483A	SIDE LABEL	
	Q44TJ026101	EPS CUSHION	
	Q44TJ026201	EPS CUSHION	
	Q44TJ026301	EPS CUSHION	
	Q44TJ026401	EPS CUSHION	
	Q45T 99609 61	EPE COVER FOR MONITOR	
	Q45T 99609 79	EPE COVER FOR BASE	
	Q50T 500523	CABLE TIE	
	Q07G 8 1 11	COMPOUND PALLET	
	Q36T 600 18120	.LOTH_GRIDDING	
	Q36T 600 36 9 GP	NONWOVEN FABRIC	
	Q36T 600 37 23 GP	NONWOVEN FABRIC	
	Q40G000162410A	S/N LABEL	
	Q40G582C786 1A	Carton label	
	Q40T0001008 1A	CARTON LABEL	
	Q40T0002008 1A	pop LABEL	

32"LCD TV**Polaroid TLM-23201B**

	Q40T0002008 2A	pop LABEL	
	Q44G600027V 9A	Carton	
	Q44T3231 21 11	EVA WASHER	
	Q44TJ019BLO001	paper sheet	
	Q45G 77 5	PE PACKING	