

REVISIONS			
REV	DESCRIPTION, ECN, EAR NO.	DATE	APP'D
F	PRODUCT DRAWING (EAR 14113)	AUG23/12	K.L.
G	PRODUCT DRAWING (EAR 14292)	AUG06/14	K.L.

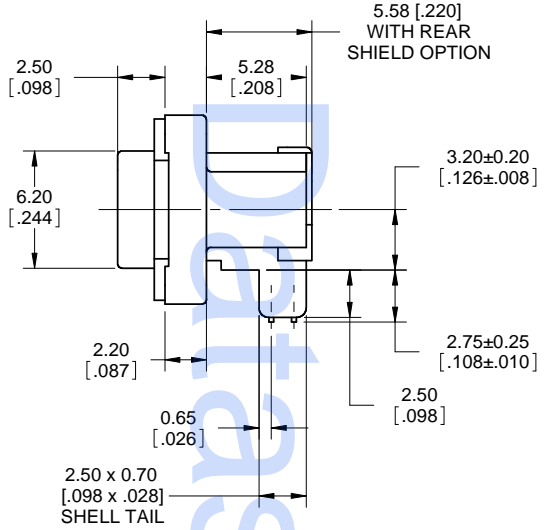
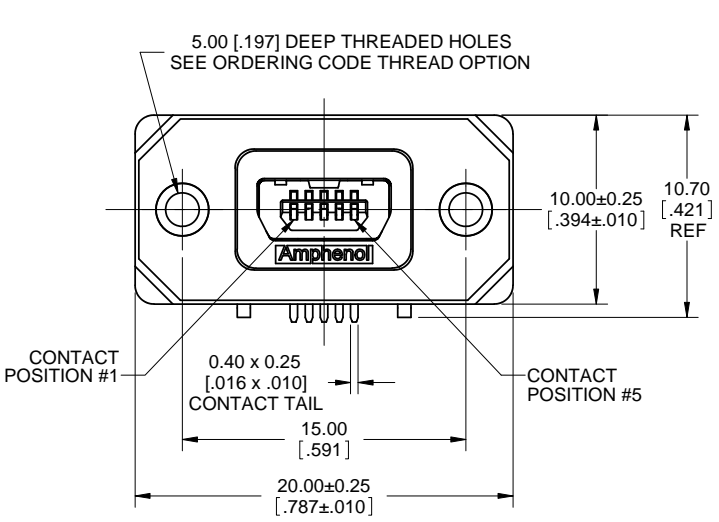

ORDERING CODE: MUSB-E151-XX

SERIES, RUGGED USB

USB 'MINI-AB' RECEPTACLE, SINGLE PORT, RIGHT ANGLE PCB TAILS

REAR SHIELD & THREAD OPTION
 0=NO REAR SHIELD, #2-56 UNC THREAD
 3= WITH REAR SHIELD, #2-56 UNC THREAD
 M= WITH REAR SHIELD, M2.5 X 0.45 THREAD
 N= NO REAR SHIELD, M2.5 X 0.45 THREAD

DUST COVER OPTION
 0=NO DUST COVER SUPPLIED
 1=WITH GREY DUST COVER SUPPLIED
 4=NO DUST COVER SUPPLIED
 5=WITH BLACK DUST COVER SUPPLIED

NOTE: THERE IS NO DIFFERENCE BETWEEN DUST COVER OPTIONS '0' AND '4'

SPECIAL CONNECTORS:
 MANY UNIQUE FEATURES ARE READILY AVAILABLE TO SUIT CUSTOMER REQUIREMENTS. CONSULT WITH AMPHENOL CANADA FOR DETAILS.

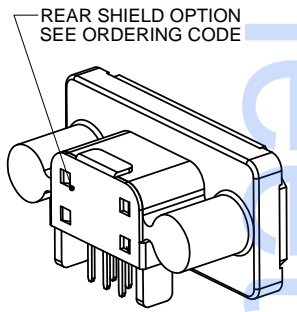
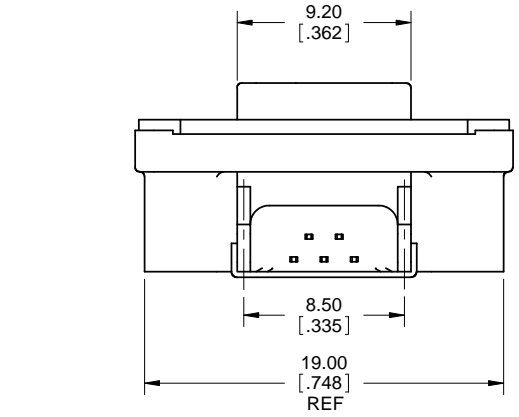

NOTES:

- MATERIAL:
ALL MATERIALS ARE RoHS COMPLIANT PER EU DIRECTIVE 2011/65/EU AND AMENDMENTS
 - OUTER SHELL: DIE CAST ZINC ALLOY, NICKEL PLATED
 - CONTACTS: PHOSPHOR BRONZE, PLATED WITH 0.76 MICRONS [30u"] GOLD OVER 1.27 MICRONS [50u"] MINIMUM NICKEL ON THE MATING AREA WITH TIN OVER NICKEL ON THE TAILS.
 - USB HOUSING: ENGINEERING THERMOPLASTIC, FLAMMABILITY RATING UL94V-0, BLACK.
 - USB SHELL & REAR SHIELD: COPPER ALLOY, NICKEL PLATED
 - GASKET: PORON WITH ADHESIVE BACKING.
 - DUST COVER: SILICONE RUBBER WITH NICKEL PLATED COPPER ALLOY BUSHING.
- ENVIRONMENTAL PERFORMANCE PER IEC 60529 CODE IP67 FOR SEAL BETWEEN MATING AREA AND PCB SIDE OF CONNECTOR. GASKET PROVIDES SEAL TO INSIDE FACE OF ENCLOSURE PANEL. AVAILABLE DUST COVERS PROVIDE ADDED PROTECTION. SEE SHEET 2 FOR APPLICATION VIEW.
- CURRENT RATING: 1 AMPERE.
- CONTACT RESISTANCE: 50 MILLIOHMS MAXIMUM.
- OPERATING TEMPERATURE: -40 °C TO +105 °C.
- DUST COVERS MAY BE ORDERED SEPARATELY. SPECIFY
 - PART NUMBER MUSB-2E151-005BP FOR GREY COVER
 - PART NUMBER MUSB-2E151-015BP FOR BLACK COVER
- RECOMMENDED TORQUE FOR PANEL MOUNT SCREWS: 0.23 TO 0.34 N.m (2.00 TO 3.00 IN-LBS) FOR SCREWS WITH 2.50mm (.098") THREAD ENGAGEMENT.
- RECOMMENDED ENCLOSURE PANEL: 1.20 TO 2.50mm (.047 TO .098") THICK.

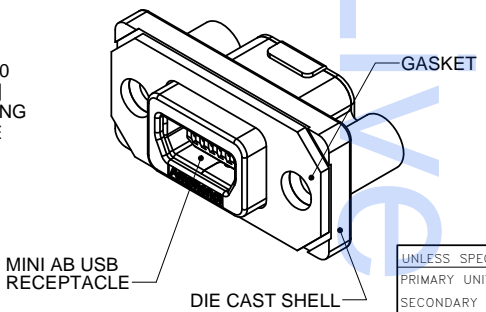
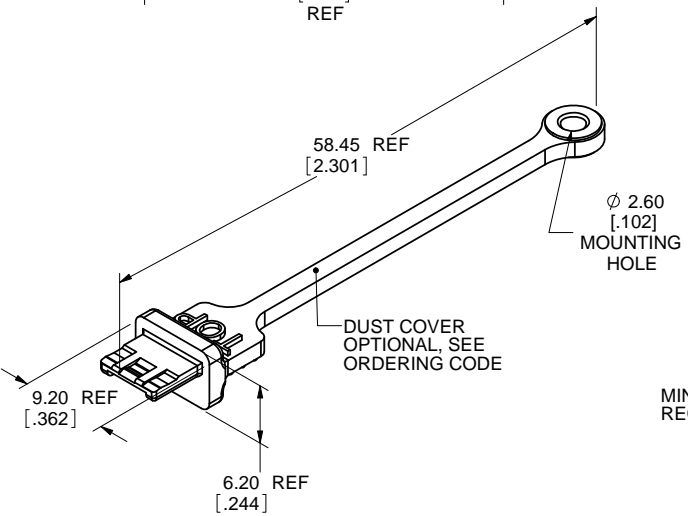

UNLESS SPECIFIED OTHERWISE	DRAWN	S.SEMENOV	AUG31/06
PRIMARY UNITS MILLIMETERS	CHECKED		
SECONDARY UNITS INCHES	M.E. APP'D		
REFERENCE IN PARENTHESES	Q.A. APP'D		
GENERAL TOLERANCES	DWG APPR.	A.GREEN	AUG31/06
1 DECIMAL PLACE	ENG. REL. NO.		
2 DECIMAL PLACES ±0.15	REF.		
3 DECIMAL PLACES	THIRD ANGLE PROJECTION		
ANGULAR DEGREES	DO NOT SCALE DRAWING		

Amphenol Canada Corp.
 www.amphenolcanada.com

MUSB SERIES RUGGED MINI-AB USB RECEPTACLE, RIGHT ANGLE PCB TAIL, THREAD & COVER OPTIONS, RoHS COMPLIANT

DWG. NO. **P-MUSB-E151-XX** REV **G**

CODE ID NO. 03554 DWG SIZE: C SCALE: 5:1 SHEET 1 OF 2

REVISIONS			
REV	DESCRIPTION, ECN, EAR NO.	DATE	APP'D
F	PRODUCT DRAWING (EAR 14113)	AUG23/12	K.L.
G	PRODUCT DRAWING (EAR 14292)	AUG06/14	K.L.

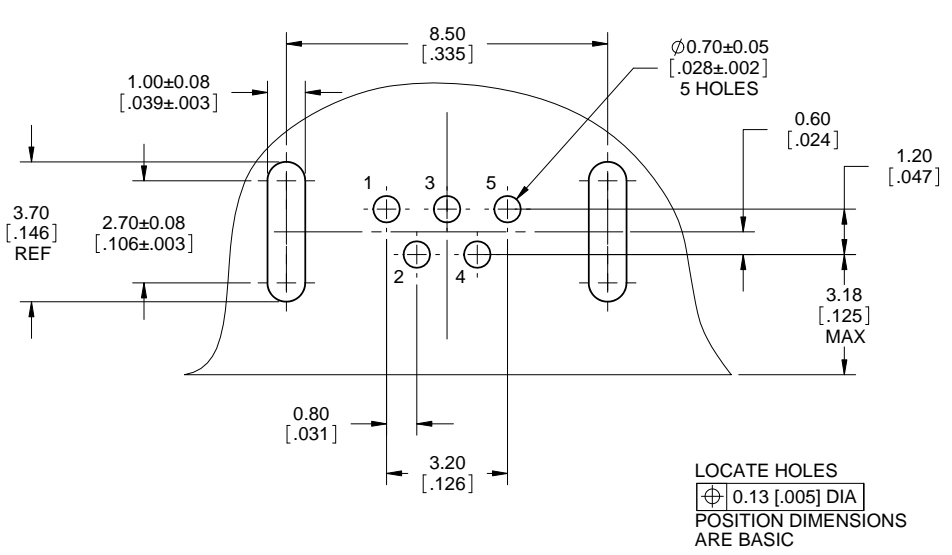

RECOMMENDED P.C.B LAYOUT
COMPONENT SIDE OF BOARD

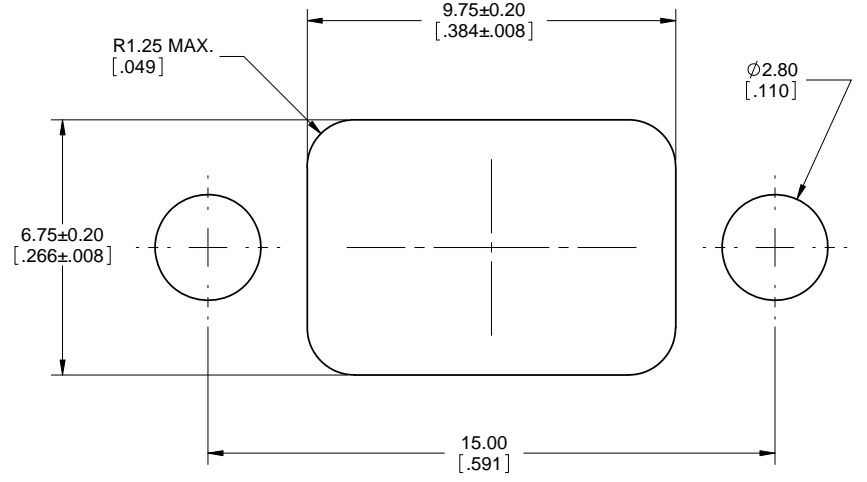

RECOMMENDED PANEL CUTOUT

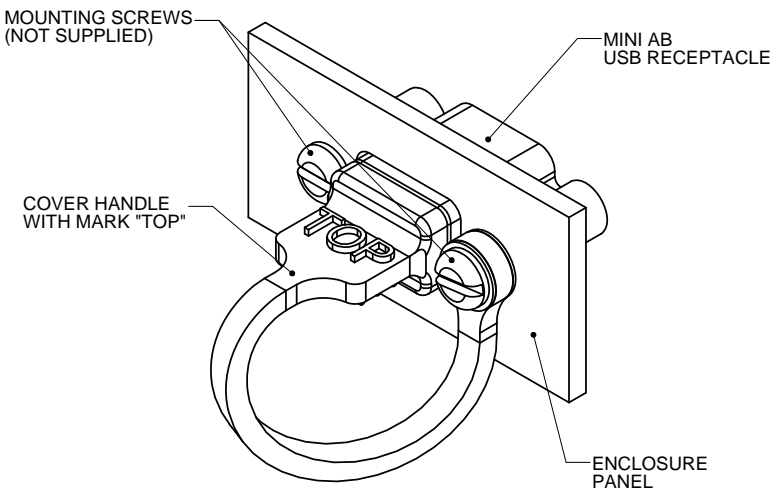

DUST COVER APPLICATION



UNLESS SPECIFIED OTHERWISE	DRAWN	S.SEMENOV	AUG31/06
PRIMARY UNITS MILLIMETERS	CHECKED		
SECONDARY INCHES	M.E. APP'D		
REFERENCE IN PARENTHESES	Q.A. APP'D		
GENERAL TOLERANCES	DWG APPR.	A.GREEN	AUG31/06
1 DECIMAL PLACE	ENG. REL. NO.		
2 DECIMAL PLACES ±0.15	REF.		
3 DECIMAL PLACES	THIRD ANGLE PROJECTION		
ANGULAR DEGREES	DO NOT SCALE DRAWING		

Amphenol Canada Corp.
www.amphenolcanada.com

MUSB SERIES RUGGED MINI-AB USB RECEPTACLE, RIGHT ANGLE PCB TAIL, THREAD & COVER OPTIONS, RoHS COMPLIANT

DWG. NO. **P-MUSB-E151-XX** REV **G**

CODE ID NO. 03554 DWG SIZE: C SCALE: 5:1 SHEET 2 OF 2