

FEATURES

- Output voltage adjustable from 4.5V to 40V (105)
- DC line regulation guaranteed at 0.03%/V
- Load regulation better than 0.1%

- Output current in excess of 10A possible by adding external resistor
- Direct, plug-in replacement for 100/300 giving improved regulation

GENERAL DESCRIPTION

The Intersil 105/305 monolithic integrated circuit is a positive voltage regulator. It is a direct replacement for the 100/300 with an extra gain stage added for improved regulation. In contrast to the 100/300, the 105/305 requires no minimum load current while permitting higher voltage operation by reducing standby current drain.

The Intersil 105/305 can be used as either a linear or switching regulator circuit with output voltages greater than 4.5V. It features fast response to both load and line transients, and freedom from oscillations with varying resistive and reactive loads.

SCHEMATIC DIAGRAM

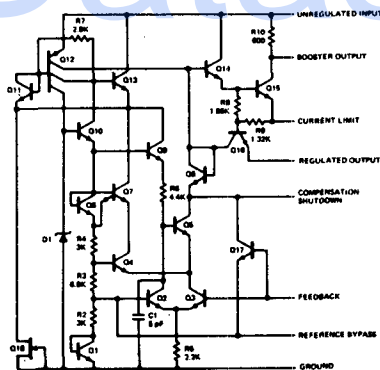

PIN CONFIGURATIONS

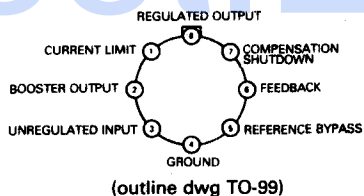

TOP VIEW
NOTE: Pin 4 connected to case

Flat Package

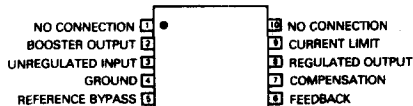

(outline dwg FB)

NOTE: Pin 4 connected to bottom of package

ORDERING INFORMATION

Part number	TO-99 Can	10 pin Flatpak	Dice
LM105	LM105H*	LM105F	LM105/D
LM305	LM305H		LM305/D

* Add /883B to order number if 883B processing is desired.

ABSOLUTE MAXIMUM RATINGS

	105	305
Input Voltage	50V	40V
Input-Output Voltage Differential	40V	40V
Power Dissipation (Note 1)	500 mW	500 mW
Operating Junction Temperature Range	-55°C to +150°C	0°C to 70°C
Storage Temperature Range	-65°C to +150°C	-55°C to 125°C
Lead Temperature (Soldering, 60 sec)	300°C	300°C

ELECTRICAL CHARACTERISTICS (Note 2)

PARAMETER	CONDITIONS	105			305			UNITS
		MIN	TYP	MAX	MIN	TYP	MAX	
Input Voltage Range		8.5		50	8.0		40	V
Output Voltage Range		4.5		40	4.5		30	V
Output-Input Voltage Differential		3.0		30	3.0		30	V
Load Regulation (Note 3)	$0 \leq I_O < 12 \text{ mA}$							
	$R_{SC} = 18\Omega, T_A = 25^\circ\text{C}$		0.02	0.05	0.02	0.05		%
	$R_{SC} = 10\Omega, T_A = 125^\circ\text{C}$		0.03	0.1				%
	$R_{SC} = 18\Omega, T_A = -55^\circ\text{C}$		0.03	0.1				%
	$R_{SC} = 15\Omega, T_A = 70^\circ\text{C}$				0.03	0.1		%
	$R_{SC} = 18\Omega, T_A = 0^\circ\text{C}$				0.03	0.1		%
Line Regulation	$V_{IN} - V_{OUT} \leq 5\text{V}$		0.025	0.06	0.025	0.06		%/V
	$V_{IN} - V_{OUT} > 5\text{V}$		0.015	0.03	0.05	0.03		%/V
Temperature Stability	$-55^\circ\text{C} \leq T_A \leq +125^\circ\text{C}$		0.3	1.0				%
	$0^\circ\text{C} \leq T_A \leq 70^\circ\text{C}$				0.3	1.0		%
Feedback Sense Voltage			1.8		1.8			V
Output Noise Voltage	$10 \text{ Hz} \leq f \leq 10 \text{ kHz}$							
	$C_{REF} = 0$		0.005		0.005			%
	$C_{REF} = 0.1 \mu\text{F}$		0.002		0.002			%
Long Term Stability			0.1	1.0	0.1	1.0		%
Standby Current Drain	$V_{IN} = 50\text{V}$		0.8	2.0				mA
	$V_{IN} = 40\text{V}$				0.8	2.0		mA
Ripple Rejection	$C_{REF} = 10 \mu\text{F}, f = 120 \text{ Hz}$		0.003	0.01	0.003	0.01		%/V

NOTE 1: The maximum junction temperature of the 105 is 150°C, while that of the 305 is 85°C. For operating at elevated temperatures devices in the TO-5 package must be derated based on a thermal resistance of 150°C/W, junction to ambient or 45°C/W, junction to case. For the flat package, the derating is based on thermal resistance of 185°C/W when mounted on a 1/16-inch-thick epoxy glass board with ten 0.03-inch-wide, 2-ounce copper conductors. Peak dissipations to 1W are allowable providing the dissipation rating is not exceeded with the power averaged over a five second interval.

NOTE 2: These specifications apply for a junction temperature between -55°C and +150°C, (105) 0°C and 70°C, (305) for input and output voltages within the ranges given, and for a divider impedance seen by the feedback terminal of 2 kΩ, unless otherwise specified. The load and line regulation specifications are for constant junction temperature. Temperature drift effects must be taken into account separately when the unit is operating under conditions of high dissipation.

NOTE 3: The output currents given, as well as the load regulation, can be increased by the addition of external transistors. The improvement factor will be roughly equal to the composite current gain of the added transistors.

5

TYPICAL PERFORMANCE CHARACTERISTICS FOR 105,305*

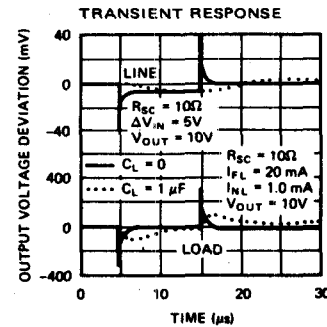
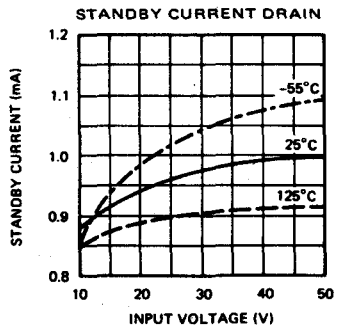
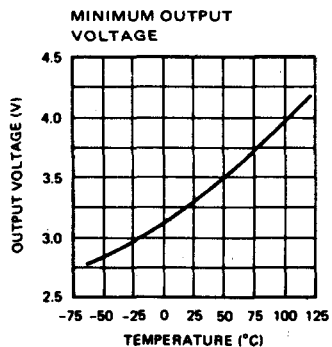
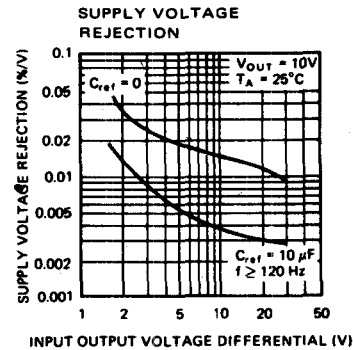
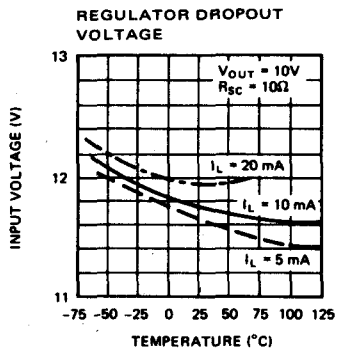
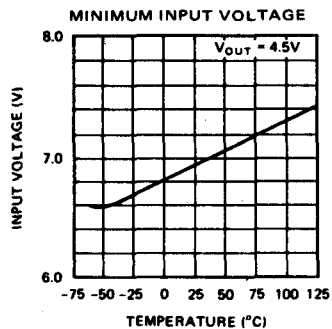
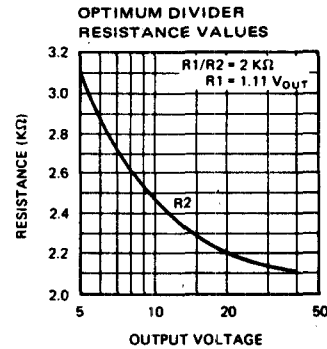
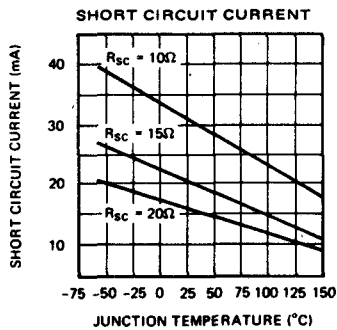
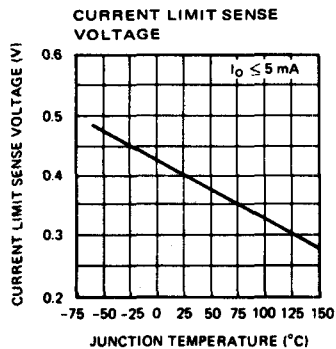
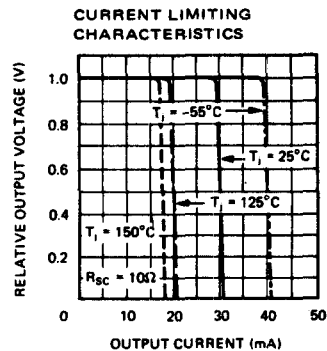
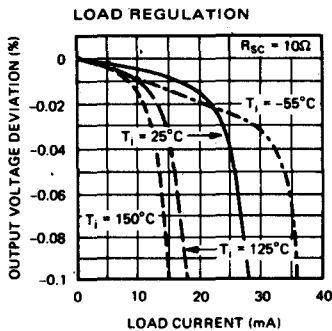
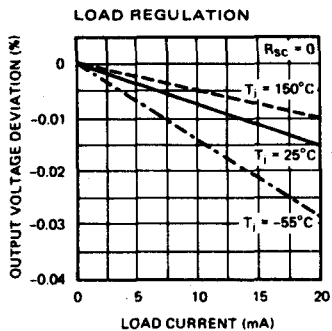

*305 only guaranteed $0^\circ\text{C} \leq T_A \leq 70^\circ\text{C}$, $V_{IN} = 40\text{ V max}$, $V_{OUT} = 30\text{ V max}$.
5-25

TYPICAL APPLICATIONS*

10A Regulator with Foldback Current Limiting

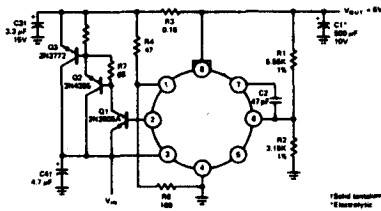

1.0A Regulator with Protective Diodes

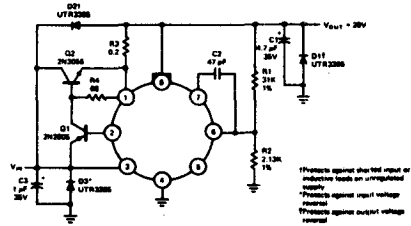

Switching Regulator

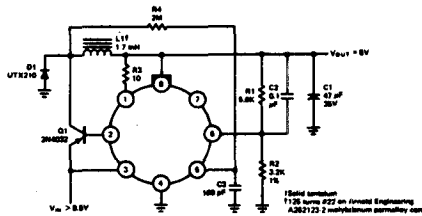

Shunt Regulator

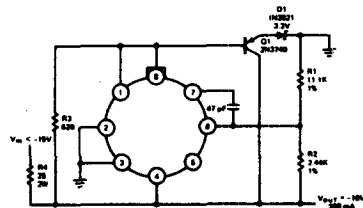

*Pin connections shown are for TO-5

5

DEFINITION OF TERMS

INPUT VOLTAGE RANGE: The range of DC input voltages over which the regulator will operate within specifications.

OUTPUT VOLTAGE RANGE: The range of regulated output voltages over which the specifications apply.

OUTPUT-INPUT VOLTAGE DIFFERENTIAL: The voltage difference between the unregulated input voltage and the regulated output voltage for which the regulator will operate within specifications.

LINE REGULATION: The percentage change in regulated output voltage for a change in input voltage.

LOAD REGULATION: The percentage change in regulated output voltage for a change in load from the minimum load to the maximum load current specified.

CURRENT-LIMIT SENSE VOLTAGE: The voltage across the current limit terminals required to cause the regulator

to current-limit with a short circuited output. This voltage is used to determine the value of the external current-limit resistor when external booster transistors are used.

TEMPERATURE STABILITY: The percentage change in output voltage for a thermal variation from room temperature to either temperature extreme.

FEEDBACK SENSE VOLTAGE: The voltage, referred to ground, on the feedback terminal of the regulator while it is operating in regulation.

OUTPUT NOISE VOLTAGE: The average AC voltage at the output with constant load and no input ripple.

STANDBY CURRENT DRAIN: That part of the operating current of the regulator which does not contribute to the load current.

RIPPLE REJECTION: The line regulation for ac input signals at or above a given frequency with a specified value of bypass capacitor on the reference bypass terminal.