

COMPLEMENTARY SILICON POWER TRANSISTORS

- SGS-THOMSON PREFERRED SALESTYPES
- COMPLEMENTARY PNP - NPN DEVICES
- FULLY MOLDED ISOLATED PACKAGE
- 2000 V DC ISOLATION(U.L. COMPLIANT)

APPLICATIONS

- GENERAL PURPOSE SWITCHING
- GENERAL PURPOSE AMPLIFIERS

DESCRIPTION

The BD241BFP is silicon epitaxial-base NPN transistors mounted in TO-220FP fully molded isolated package.

It is intended for power linear and switching applications.

The complementary PNP types is the BD242BFP.

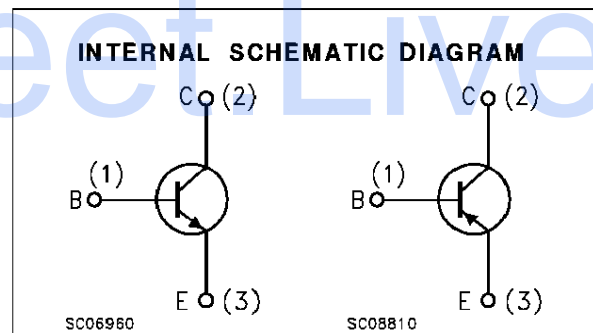
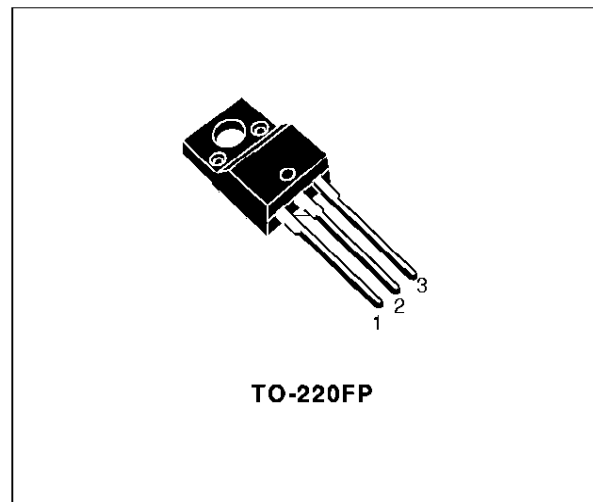

ABSOLUTE MAXIMUM RATINGS

Symbol	Parameter	Value		Unit
		NPN	PNP	
V_{CER}	Collector-Base Voltage ($R_{BE} = 100 \Omega$)	BD241BFP		V
V_{CEO}	Collector-Emitter Voltage ($I_B = 0$)	BD242BFP		
V_{EBO}	Emitter-Base Voltage ($I_C = 0$)			V
I_C	Collector Current			A
I_{CM}	Collector Peak Current			A
I_B	Base Current			A
P_{tot}	Total Dissipation at $T_c \leq 25^\circ C$			W
T_{sig}	Storage Temperature			$^\circ C$
T_j	Max. Operating Junction Temperature			$^\circ C$

For PNP types voltage and current values are negative.

BD241BFP / BD242BFP

THERMAL DATA

$R_{thj-case}$	Thermal Resistance Junction-case	Max	5.3	$^{\circ}C/W$
----------------	----------------------------------	-----	-----	---------------

ELECTRICAL CHARACTERISTICS ($T_{case} = 25^{\circ}C$ unless otherwise specified)

Symbol	Parameter	Test Conditions	Min.	Typ.	Max.	Unit
I_{CEO}	Collector Cut-off Current ($I_B = 0$)	$V_{CE} = 60 V$			0.3	mA
I_{CES}	Collector Cut-off Current ($V_{BE} = 0$)	$V_{CE} = 80 V$			0.2	mA
I_{EBO}	Emitter Cut-off Current ($I_C = 0$)	$V_{EB} = 5 V$			1	mA
$V_{CEO(sus)*}$	Collector-Emitter Sustaining Voltage ($I_B = 0$)	$I_C = 30 mA$	80			V
$V_{CE(sat)*}$	Collector-Emitter Saturation Voltage	$I_C = 3 A$ $I_B = 0.6 A$			1.2	V
$V_{BE(ON)*}$	Base-Emitter Voltage	$I_C = 3 A$ $V_{CE} = 4 V$			1.8	V
h_{FE*}	DC Current Gain	$I_C = 1 A$ $V_{CE} = 4 V$ $I_C = 3 A$ $V_{CE} = 4 V$	25 10			

* Pulsed: Pulse duration = 300 μs , duty cycle $\leq 2\%$
For PNP types voltage and current values are negative.

TO-220FP MECHANICAL DATA

DIM.	mm			inch		
	MIN.	TYP.	MAX.	MIN.	TYP.	MAX.
A	4.4		4.6	0.173		0.181
B	2.5		2.7	0.098		0.106
D	2.5		2.75	0.098		0.108
E	0.45		0.7	0.017		0.027
F	0.75		1	0.030		0.039
F1	1.15		1.7	0.045		0.067
F2	1.15		1.7	0.045		0.067
G	4.95		5.2	0.195		0.204
G1	2.4		2.7	0.094		0.106
H	10		10.4	0.393		0.409
L2		16			0.630	
L3	28.6		30.6	1.126		1.204
L4	9.8		10.6	0.385		0.417
L6	15.9		16.4	0.626		0.645
L7	9		9.3	0.354		0.366
Ø	3		3.2	0.118		0.126

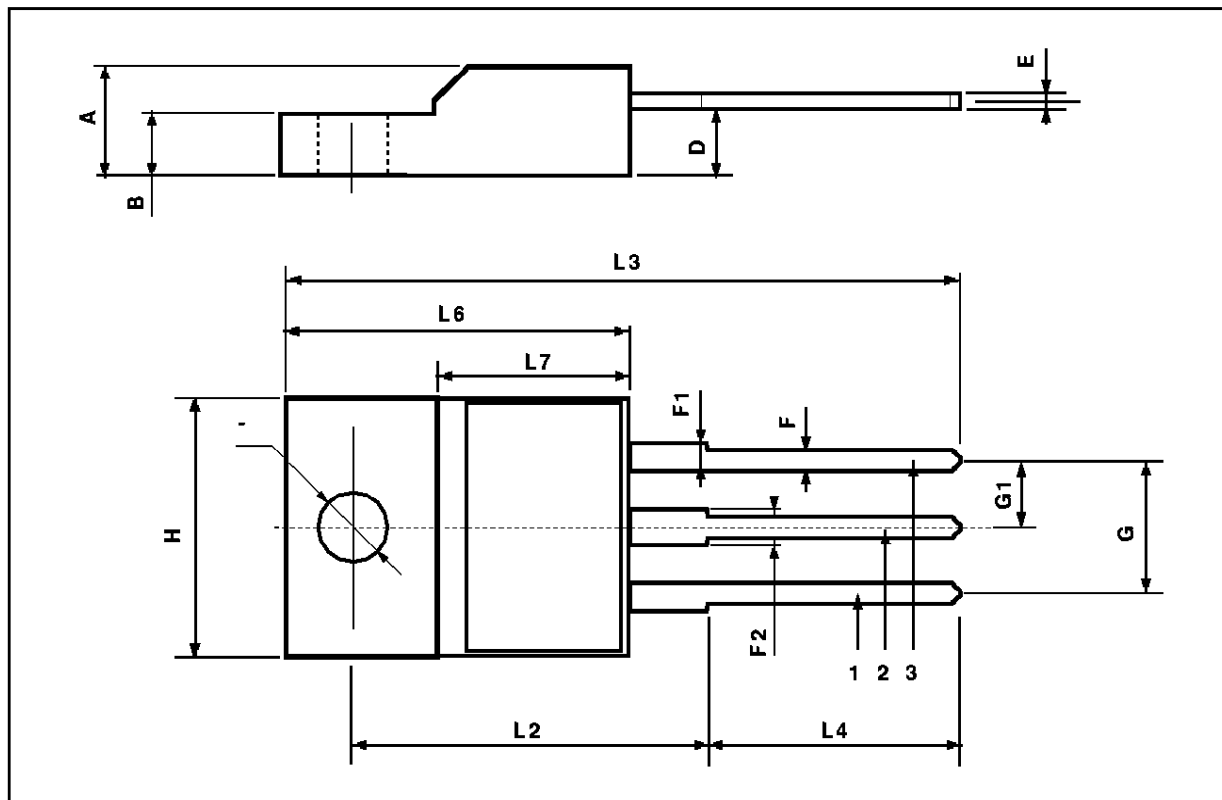

Information furnished is believed to be accurate and reliable. However, SGS-THOMSON Microelectronics assumes no responsibility for the consequences of use of such information nor for any infringement of patents or other rights of third parties which may result from its use. No license is granted by implication or otherwise under any patent or patent rights of SGS-THOMSON Microelectronics. Specifications mentioned in this publication are subject to change without notice. This publication supersedes and replaces all information previously supplied. SGS-THOMSON Microelectronics products are not authorized for use as critical components in life support devices or systems without express written approval of SGS-THOMSON Microelectronics.

© 1998 SGS-THOMSON Microelectronics - Printed in Italy - All Rights Reserved

SGS-THOMSON Microelectronics GROUP OF COMPANIES
Australia - Brazil - Canada - China - France - Germany - Italy - Japan - Korea - Malaysia - Malta - Morocco - The Netherlands -
Singapore - Spain - Sweden - Switzerland - Taiwan - Thailand - United Kingdom - U.S.A