

## Features and Application

MIL-DTL-38999 Series III is the newest cylindrical connector designed for highest performance capabilities used in both general purpose and severe environment applications.

These connectors feature an improved “one-turn” coupling system, utilizing self-locking acme thread. Acme threads provide coupling durability, while thicker wall sections and greater coupling surface area improve strength and shock resistance. Blunting of the threads on both receptacle and plug coupling nut eliminates cross threading.

Elongated mounting holes permit the Series III Connector to intermount with various existing Mil-spec flange mounted receptacles, giving it a design replacement advantage.

Wall mount receptacle, jam nut receptacle and straight self-locking RFI plug are offered in 9 shell sizes and 54 insert arrangements utilizing M39029 contacts in sizes 22D, 20, 16, 12, 10 power and 8 twinax.

These connectors are available in wide range of shell materials and finishes. Aluminum shells are offered in electroless nickel and olive drab cadmium. Other finishes such as anodic and zinc nickel are available upon request to commercial callouts only. In addition, we offer stainless steel shells (both passivated and electro-deposited nickel plated) with firewall inserts, and for highly corrosive environments, nickel-aluminum-bronze shells with standard environment-resisting inserts (commercial callouts only).

**MIL-STD-1560 Insert Arrangements** – Series III connectors use insert patterns and contacts common to Series I, making for an easy transition from bayonet to triple-lead, acme-thread, self-locking coupling.

**Metal-to-Metal Bottoming** – This feature precludes relative shell-to-shell motion, which may result in ordinary connector wear and moisture entrapment.

**Lockwiring Eliminated** – Self-locking quick coupling plug eliminates the need for lockwiring.

**Firewall Capability** - Stainless steel shells in both K and S firewall classes are offered.

**Universal I/R Tool** – A single, expendable plastic tool is used for both insertion and removal of contacts.

**Scoop-Proof Design** – Recessed pins in elongated shells minimize the possibility for contact damage. In a blind mating application, mating shells cannot “scoop” the pins, and cause a shorting or bending of contacts.

**Closed-Entry Socket Insert** – Hard dielectric socket face has lead-in chamfers for positive alignment of pins (even partially bent within pre-established limits) with sockets.

**Interfacial Pin Insert Seal** – Raised moisture barriers around each pin, which mate into lead-in chamfers of hard face socket insert, provide individual contact sealing. Interfacial seal is never touched by service tools.

**Elastomer Wire Sealing Grommet** – Sealing over a wide range of wire diameters is assured by a triple wire seal in each cavity at the rear of the connector.

**Superior Contact Stability** – Rear release crimp contact system features a stamped beryllium-copper retaining clip captivated by molded-in shoulders of each contact cavity in the insulator. A rear-inserted M81969 plastic tool expands the tines beyond the shoulder, releasing the contact.

**Metric Accessory Thread** – Metric thread results in additional wall thickness giving greater strength and shock resistance.





## Performance Specifications

### Operating Temperature Range

Classes F, K, S and BZ\*: -65°C to +200°C (-85°F to +392°F)  
 Classes W and ZC\*: -65°C to +175°C (-85°F to +347°F)

### Material and Finish Data (Class)

F – aluminum shell, electroless nickel finish  
 K – stainless steel shell, passivated, firewall  
 S – stainless steel shell, electrodeposited nickel, firewall  
 W – aluminum shell, olive drab cadmium over nickel base  
 BZ\* – aluminum nickel bronze shell, std insert  
 Z\* – aluminum shell, zinc nickel finish

### Corrosion Resistance

Classes K, W, BZ\* and Z\* withstand 500-hour salt spray.  
 Classes F and S withstand 48-hour salt spray.

### Durability

Minimum of 500 mating cycles.

### Fluid Resistance

Connectors resist specified immersions in MIL-PRF-7808, MIL-PRF-23699, MIL-PRF-5606, M2-V Chevron oil, Coolanol 25, MIL-DTL-83133 (JP-8), MIL-DTL-5624 (JP-4, JP-5), SAE-AMS1424 Type I, and other solvents and cleaning agents.

### Shielding Effectiveness

RFI and EMI attenuation at the specified frequencies meet the requirements of MIL-DTL-38999.

- RFI shielding effectiveness of mated connectors with RFI backshells is measured in a triaxial radio frequency leakage fixture.
- EMI shielding effectiveness is measured at the interface of mated connectors and tested by the mode-stirred technique specified in method 3008 of MIL-STD-1344.

### Voltage Rating

| Service Rating | Suggested Operating Voltage |      | Test Voltage | Test Voltage | Test Voltage | Test Voltage |
|----------------|-----------------------------|------|--------------|--------------|--------------|--------------|
|                | (Sea Level)                 |      | Sea Level    | 50,000 Ft.   | 70,000 Ft.   | 100,000 Ft.  |
|                | AC (RMS)                    | DC   | V RMS        | V RMS        | V RMS        | V RMS        |
| M              | 400                         | 550  | 1300         | 550          | 350          | 200          |
| N              | 300                         | 450  | 1000         | 400          | 260          | 200          |
| I              | 600                         | 850  | 1800         | 600          | 400          | 200          |
| II             | 900                         | 1250 | 2300         | 800          | 500          | 200          |

**Note:** The establishment of electrical safety factors is left entirely to the designer, as he is in the best position to know

### Environmental Seal

Wired, mated connectors with specified accessories attached, shall meet the altitude-immersion test specified in MIL-DTL-38999.

### Shell-to-Shell Conductivity

Maximum potential drop shall not exceed:

- Classes F and S = 1.0 millivolt.
- Class W = 2.5 millivolts, Class K = 10.0 millivolts

### Shock and Vibration Requirements

Wired, mated connectors shall not be damaged, nor shall there be a current interruption longer than one microsecond when subjected to the following:

#### Shock

Pulse of approximate half sine wave of 300 G ± 15 percent magnitude with duration of 3 ± 1 milliseconds applied in three axes.

#### High Impact Shock

When mounted as specified in MIL-S-901, grade A, a drop of a 400 lb. Hammer from 1 foot, 3 feet and 5 feet applied to connector in three axes, totaling nine impacts.

#### Vibration

Wired and mated connectors withstand the following vibration levels:

- Sine vibration where connector samples with simulated accessory load are subjected to simple harmonic motion from 10 to 2,000 Hz in three mutually perpendicular axes, in 20 minute sweeps, for 12 hours in each axis at velocity of 254 mm/sec from 10-50 Hz, displacement of 1.5 mm from 50-140Hz and acceleration of 60G from 140-2,000Hz.
- Random Vibration per MIL-STD-1344, method 205, test condition V at ambient temperature and test condition VI, Letter “J” at elevated temperature.

\* Not on QPL, can be supplied to Aero-Electric part number only.

exactly what peak voltages, switching currents, transients, etc., can be expected in a particular circuit.

MIL-DTL-38999 S III

**MIL-DTL-38999**  
**Part Number Development**  
**Series III**



Military and Aero-Electric Part Number Development

|  |                |           |          |          |           |          |          |             |
|--|----------------|-----------|----------|----------|-----------|----------|----------|-------------|
| <b>Mil. Prefix</b>   | <b>D38999/</b> | <b>20</b> | <b>W</b> | <b>C</b> | <b>35</b> | <b>P</b> | <b>N</b> |             |
| <b>Aero Prefix</b>   | <b>AE3</b>     | <b>20</b> | <b>W</b> | <b>C</b> | <b>35</b> | <b>P</b> | <b>N</b> | <b>-340</b> |
| <b>Shell Type (Specification Sheet Number)</b>                                 |                |           |          |          |           |          |          |             |
| 20 = Wall mount receptacle   |                |           |          |          |           |          |          |             |
| 24 = Jam nut receptacle  |                |           |          |          |           |          |          |             |
| 26 = Self-locking, RFI grounding plug  |                |           |          |          |           |          |          |             |
| <b>Class (Material &amp; Finish)</b>   |                |           |          |          |           |          |          |             |
| F = Aluminum shell, electroless nickel finish                                  |                |           |          |          |           |          |          |             |
| W = Aluminum shell, olive drab cadmium over electroless nickel base            |                |           |          |          |           |          |          |             |
| K = Stainless steel shell, passivated, with firewall insert                    |                |           |          |          |           |          |          |             |
| S = Stainless steel shell, electrodeposited nickel, with firewall insert       |                |           |          |          |           |          |          |             |
| BZ* = Aluminum nickel bronze shell with standard insert (Aero p/n only)        |                |           |          |          |           |          |          |             |
| Z* = Aluminum shell, zinc nickel plating (Aero p/n only)                       |                |           |          |          |           |          |          |             |
| <b>Shell Size</b>  |                |           |          |          |           |          |          |             |
| A, B, C, D, E, F, G, H or J  |                |           |          |          |           |          |          |             |
| <b>Insert Arrangement</b>  |                |           |          |          |           |          |          |             |
| See pages 15 thru 19   |                |           |          |          |           |          |          |             |
| <b>Contact Style</b>   |                |           |          |          |           |          |          |             |
| P = Pin  |                |           |          |          |           |          |          |             |
| S = Socket   |                |           |          |          |           |          |          |             |
| A = Pin connector less pins (with intent to use non-std pin contacts)          |                |           |          |          |           |          |          |             |
| B = Socket connector less sockets (with intent to use non-std socket contacts) |                |           |          |          |           |          |          |             |
| <b>Polarization (Keying)</b>   |                |           |          |          |           |          |          |             |
| N = Normal (Included in part number)   |                |           |          |          |           |          |          |             |
| A, B, C, D, or E   |                |           |          |          |           |          |          |             |
| <b>Modification (applies to Aero part numbers only)</b>                        |                |           |          |          |           |          |          |             |
| 01 = Less contacts (is not marked on the part)                                 |                |           |          |          |           |          |          |             |
| 340 = Connector kitted with M85049/14-XXX                                      |                |           |          |          |           |          |          |             |
| 341 = Connector kitted with M85049/38-XXX straight clamp                       |                |           |          |          |           |          |          |             |
| 342 = Connector kitted with M85049/39-XXX right angle clamp                    |                |           |          |          |           |          |          |             |
| Consult factory for other modifications  |                |           |          |          |           |          |          |             |

\* Not on QPL, can be supplied to Aero-Electric part number only.

**Note 1:** Each connector is furnished with contacts unless ordered less contacts (L/C) as follows: One spare contact for inserts requiring 2 through 26 of each contact and two spares for inserts with 27 or more contacts, and a minimum of one sealing plug up to 10% of the number contacts. Spare Coax and Twinax contacts are not supplied. One insertion/extraction tool for each contact size is also included.

**Note 2:** Proper part number marking has no “0” in front of single digit layout. Example: JD38999/20WB5SN. “N” for normal is included. In addition, J or JAN must be marked immediately in front of MIL part number.

MIL-DTL-38999 S III

Triple Start Threaded Coupling, Crimp Removable, Rear Release, Scoop-Proof

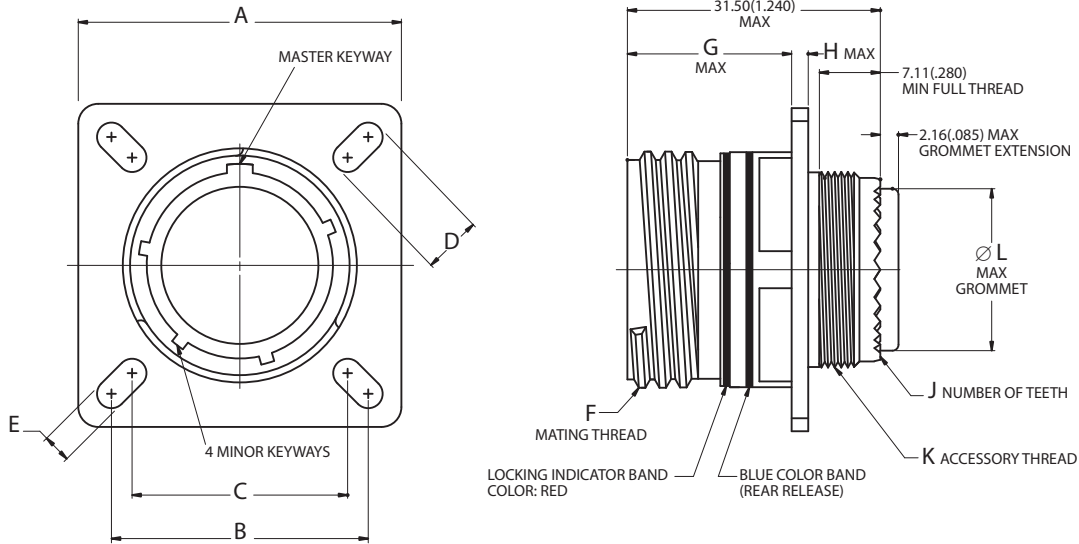

Page 38 Completed Part Number  
 Page 44 Contacts, Sealing Plugs and Tools  
 Pages 17–19 Insert Arrangements  
 Page 37 Performance Specifications  
 Pages 15, 16 Insert Availability and Contact Information  
 Page 42 Polarization

**Note 1:** “K” Accessory Thread for AE320 is same as AE326 (“D” Accessory Thread) on page 41.

**Note 2:** “F” Mating Thread for AE320 is same as AE326 (“E” Mating Thread) on page 41 except it is Class 2A.

**Note 3:** Maximum Grommet Extension for insert layouts incorporating size 8 and 10 contacts = **5.95(.234)**.

| Shell Size | A     |       | B     |       | C     |       | D     |      | E     |      | G       |       | H       |      | J            | Ø L     |       |
|------------|-------|-------|-------|-------|-------|-------|-------|------|-------|------|---------|-------|---------|------|--------------|---------|-------|
|            | ±.012 | ±.30  | (TP)  |       | (TP)  |       | ±.008 | ±.20 | ±.008 | ±.20 | Maximum |       | Maximum |      | No. of Teeth | Maximum |       |
|            | inch  | mm    | inch  | mm    | inch  | mm    | inch  | mm   | inch  | mm   | inch    | mm    | inch    | mm   |              | inch    | mm    |
| A          | .937  | 23.80 | .719  | 18.26 | .594  | 15.09 | .216  | 5.49 | .128  | 3.25 | .820    | 20.83 | .098    | 2.50 | 12           | .299    | 7.59  |
| B          | 1.031 | 26.20 | .812  | 20.62 | .719  | 18.26 | .194  | 4.93 | .128  | 3.25 | .820    | 20.83 | .098    | 2.50 | 16           | .427    | 10.85 |
| C          | 1.126 | 28.60 | .906  | 23.01 | .812  | 20.62 | .194  | 4.93 | .128  | 3.25 | .820    | 20.83 | .098    | 2.50 | 20           | .541    | 13.74 |
| D          | 1.220 | 31.00 | .969  | 24.61 | .906  | 23.01 | .173  | 4.39 | .128  | 3.25 | .820    | 20.83 | .098    | 2.50 | 24           | .666    | 16.92 |
| E          | 1.311 | 33.30 | 1.062 | 26.97 | .969  | 24.61 | .194  | 4.93 | .128  | 3.25 | .820    | 20.83 | .098    | 2.50 | 28           | .791    | 20.09 |
| F          | 1.437 | 36.50 | 1.156 | 29.36 | 1.062 | 26.97 | .194  | 4.93 | .128  | 3.25 | .820    | 20.83 | .098    | 2.50 | 32           | .897    | 22.78 |
| G          | 1.563 | 39.70 | 1.250 | 31.75 | 1.156 | 29.36 | .194  | 4.93 | .128  | 3.25 | .790    | 20.07 | .126    | 3.20 | 36           | 1.022   | 25.96 |
| H          | 1.689 | 42.90 | 1.375 | 34.93 | 1.250 | 31.75 | .242  | 6.15 | .154  | 3.91 | .790    | 20.07 | .126    | 3.20 | 40           | 1.147   | 29.13 |
| J          | 1.811 | 46.00 | 1.500 | 38.10 | 1.375 | 34.93 | .242  | 6.15 | .154  | 3.91 | .790    | 20.07 | .126    | 3.20 | 44           | 1.272   | 32.31 |

D38999/24

Jam Nut Receptacle  
AE324



Triple Start Threaded Coupling, Crimp Removable, Rear Release, Scoop-Proof

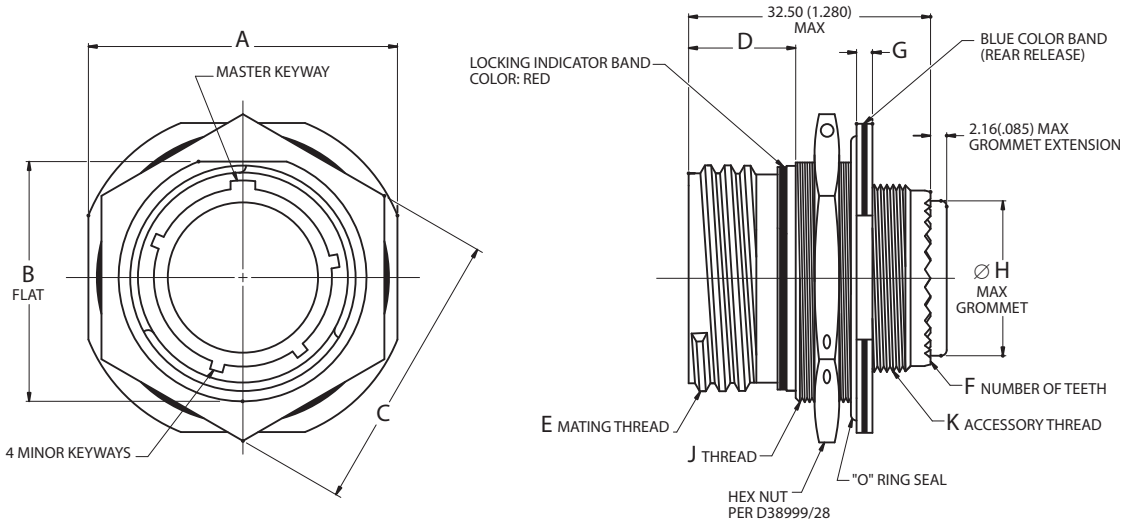

PANEL THICKNESS  
3.20(.126)  
1.58(.062)

Page 38 Completed Part Number  
Page 44 Contacts, Sealing Plugs and Tools  
Pages 17-19 Insert Arrangements  
Page 37 Performance Specifications  
Pages 15, 16 Insert Availability and Contact Information  
Page 42 Polarization

**Note 1:** "K" Accessory Thread for AE324 is same as AE326 ("D" Accessory Thread) on page 41.

**Note 2:** "E" Mating Thread for AE324 is same as AE326 ("E" Mating Thread) on page 41 except it is Class 2A.

**Note 3:** Maximum Grommet Extension for insert layouts incorporating size 8 and 10 contacts = 5.95(.234).

| Shell Size | A             |            | B                    |                  | C           |             | D    |       | F               | G                    |                  | Ø H   |       | J                 |
|------------|---------------|------------|----------------------|------------------|-------------|-------------|------|-------|-----------------|----------------------|------------------|-------|-------|-------------------|
|            | ±.016<br>inch | ±.40<br>mm | +004<br>-006<br>inch | +10<br>-15<br>mm | inch        | mm          | inch | mm    | No. of<br>Teeth | +035<br>-004<br>inch | +90<br>-10<br>mm | inch  | mm    | Jam Nut<br>Thread |
| A          | 1.063         | 27.00      | .651                 | 16.53            | .945/1.859  | 24.00/21.82 | .555 | 14.10 | 12              | .087                 | 2.20             | .299  | 7.59  | M17x1-6g          |
| B          | 1.252         | 31.80      | .751                 | 19.07            | 1.063/1.984 | 27.00/24.99 | .555 | 14.10 | 16              | .087                 | 2.20             | .427  | 10.85 | M20x1-6g          |
| C          | 1.374         | 34.90      | .938                 | 23.82            | 1.260/1.172 | 32.00/29.77 | .555 | 14.10 | 20              | .087                 | 2.20             | .541  | 13.74 | M25x1-6g          |
| D          | 1.500         | 38.10      | 1.062                | 26.97            | 1.417/1.296 | 36.00/32.91 | .555 | 14.10 | 24              | .087                 | 2.20             | .666  | 16.92 | M28x1-6g          |
| E          | 1.626         | 41.30      | 1.187                | 30.15            | 1.457/1.422 | 37.00/36.12 | .555 | 14.10 | 28              | .087                 | 2.20             | .791  | 20.09 | M32x1-6g          |
| F          | 1.811         | 46.00      | 1.312                | 33.32            | 1.614/1.546 | 41.00/39.26 | .555 | 14.10 | 32              | .118                 | 3.00             | .897  | 22.78 | M35x1-6g          |
| G          | 1.937         | 49.20      | 1.437                | 36.50            | 1.811/1.672 | 46.00/42.47 | .555 | 14.10 | 36              | .118                 | 3.00             | 1.022 | 25.96 | M38x1-6g          |
| H          | 2.063         | 52.40      | 1.562                | 39.67            | 1.969/1.796 | 50.00/45.61 | .555 | 14.10 | 40              | .118                 | 3.00             | 1.147 | 29.13 | M41x1-6g          |
| J          | 2.189         | 55.60      | 1.687                | 42.85            | 2.017/1.939 | 51.23/49.25 | .555 | 14.10 | 44              | .118                 | 3.00             | 1.272 | 32.31 | M44x1-6g          |

MIL-DTL-38999 S III

Triple Start Threaded Coupling, Crimp Removable, Rear Release, Scoop-Proof

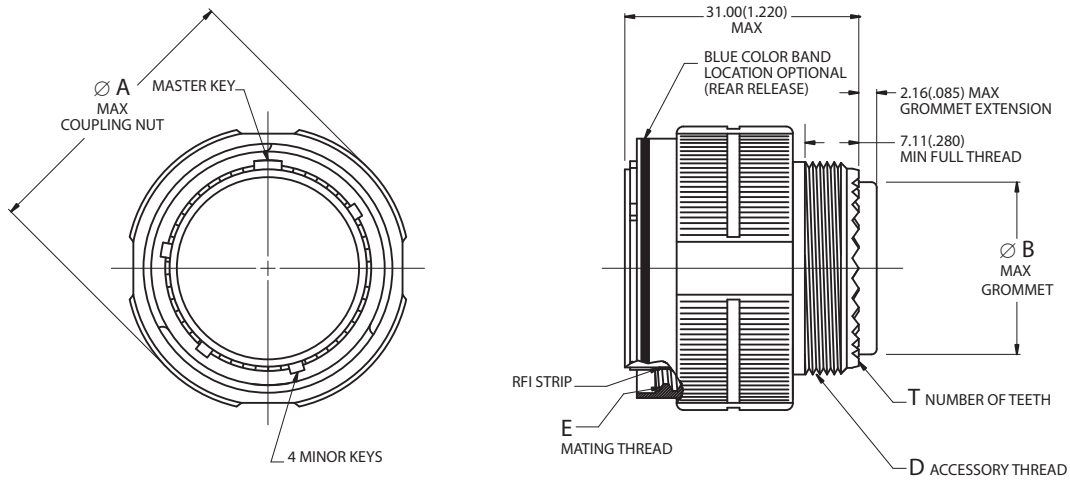

|              |   |
|--------------|---|
| Page 38      | Completed Part Number                       |
| Page 44      | Contacts, Sealing Plugs and Tools           |
| Pages 17-19  | Insert Arrangements                         |
| Page 37      | Performance Specifications                  |
| Pages 15, 16 | Insert Availability and Contact Information |
| Page 42      | Polarization                                |

**Note :** Maximum Grommet Extension for insert layouts incorporating size 8 and 10 contacts = **5.95**(.234).

| Shell Size | Ø A     |              | Ø B     |              | D                        | E                      | T            |
|------------|---------|--------------|---------|--------------|--------------------------|------------------------|--------------|
|            | Maximum |              | Maximum |              | Accessory Thread Metric  | Mating Thread Class 2B | No. of Teeth |
|            | inch    | mm           | inch    | mm           |                          |                        |              |
| A          | .858    | <b>21.80</b> | .299    | <b>7.59</b>  | <b>M12x1.0-6g 0.100R</b> | .6250-0.1P-0.3L        | 12           |
| B          | .984    | <b>25.00</b> | .427    | <b>10.85</b> | <b>M15x1.0-6g 0.100R</b> | .7500-0.1P-0.3L        | 16           |
| C          | 1.157   | <b>29.40</b> | .541    | <b>13.74</b> | <b>M18x1.0-6g 0.100R</b> | .8750-0.1P-0.3L        | 20           |
| D          | 1.280   | <b>32.50</b> | .666    | <b>16.92</b> | <b>M22x1.0-6g 0.100R</b> | 1.0000-0.1P-0.3L       | 24           |
| E          | 1.406   | <b>35.70</b> | .791    | <b>20.09</b> | <b>M25x1.0-6g 0.100R</b> | 1.1875-0.1P-0.3L       | 28           |
| F          | 1.516   | <b>38.50</b> | .897    | <b>22.78</b> | <b>M28x1.0-6g 0.100R</b> | 1.2500-0.1P-0.3L       | 32           |
| G          | 1.642   | <b>41.70</b> | 1.022   | <b>25.96</b> | <b>M31x1.0-6g 0.100R</b> | 1.3750-0.1P-0.3L       | 36           |
| H          | 1.768   | <b>44.90</b> | 1.147   | <b>29.13</b> | <b>M34x1.0-6g 0.100R</b> | 1.5000-0.1P-0.3L       | 40           |
| J          | 1.890   | <b>48.00</b> | 1.272   | <b>32.31</b> | <b>M37x1.0-6g 0.100R</b> | 1.6250-0.1P-0.3L       | 44           |

Keying Positions

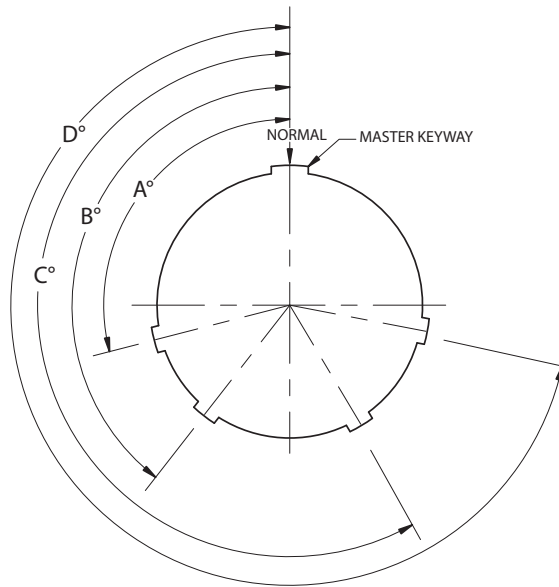

Notes:

1. Mating face of receptacle shown (plug is opposite).
2. All minor keyways (keys) are rotated to provide shell polarization while master keyway (key) remains fixed as shown.
3. The angles for a given connector are the same whether it contains pin or socket inserts.
4. Insert arrangement does not rotate relative to the master keyway (key).

| Shell Size                                     | Key/Keyway            | Key/Keyway Positions |     |     |     |
|--|-----------------------|----------------------|-----|-----|-----|
|  | Identification Letter | A°                   | B°  | C°  | D°  |
| A (9)  | N                     | 105                  | 140 | 215 | 265 |
|  | A                     | 102                  | 132 | 248 | 320 |
|  | B                     | 80                   | 118 | 230 | 312 |
|  | C                     | 35                   | 140 | 205 | 275 |
|  | D                     | 64                   | 155 | 234 | 304 |
| B (11)<br>C (13)<br>D (15)                     | E                     | 91                   | 131 | 197 | 240 |
|  | N                     | 95                   | 141 | 208 | 236 |
|  | A                     | 113                  | 156 | 182 | 292 |
|  | B                     | 90                   | 145 | 195 | 252 |
|  | C                     | 53                   | 156 | 220 | 255 |
| E (17)<br>F (19)<br>G (21)<br>H (23)<br>J (25) | D                     | 119                  | 146 | 176 | 298 |
|  | E                     | 51                   | 141 | 184 | 242 |
|  | N                     | 80                   | 142 | 196 | 293 |
|  | A                     | 135                  | 170 | 200 | 310 |
|  | B                     | 49                   | 169 | 200 | 244 |
|  | C                     | 66                   | 140 | 200 | 257 |
|  | D                     | 62                   | 145 | 180 | 280 |
|  | E                     | 79                   | 153 | 197 | 272 |

Panel Cutouts

FLANGE MOUNT

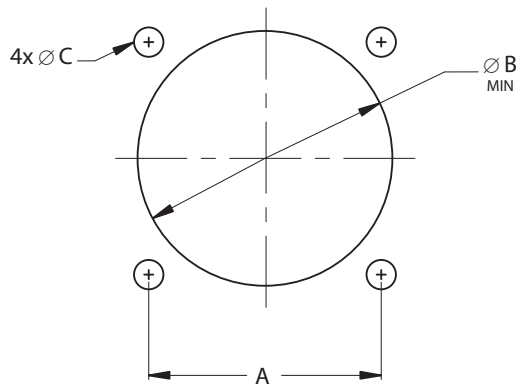

JAM NUT

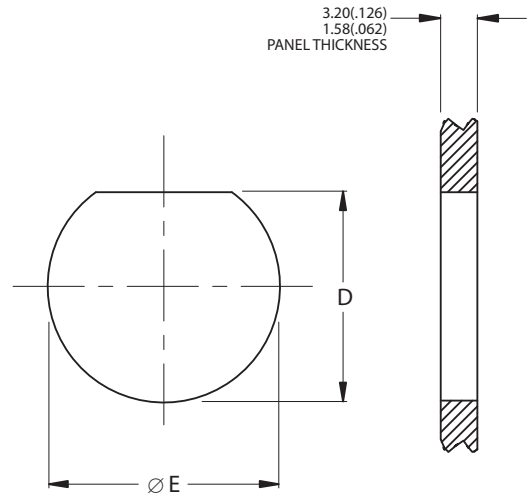

**Note:** Diameter B cutout dimensions are listed separately for back and front of panel mounting.

| Shell Size | A     |       | $\varnothing B$           |       | $\varnothing B$            |       | $\varnothing C$ |           | D      |       | $\varnothing E$ |       |
|------------|-------|-------|---------------------------|-------|----------------------------|-------|-----------------|-----------|--------|-------|-----------------|-------|
|            | (TP)  |       | For Back Mounting Minimum |       | For Front Mounting Minimum |       | $\pm .005$      | $\pm .13$ | + .000 | + .00 | + .010          | + .25 |
|            | inch  | mm    | inch                      | mm    | inch                       | mm    | inch            | mm        | inch   | mm    | inch            | mm    |
| A (9)      | .719  | 18.26 | .656                      | 16.66 | .516                       | 13.11 | .128            | 3.25      | .670   | 17.02 | .700            | 17.78 |
| B (11)     | .812  | 20.62 | .796                      | 20.22 | .625                       | 15.88 | .128            | 3.25      | .771   | 19.59 | .825            | 20.96 |
| C (13)     | .906  | 23.01 | .922                      | 23.42 | .750                       | 19.05 | .128            | 3.25      | .955   | 24.26 | 1.010           | 25.65 |
| D (15)     | .969  | 24.61 | 1.047                     | 26.59 | .906                       | 23.01 | .128            | 3.25      | 1.085  | 27.56 | 1.135           | 28.83 |
| E (17)     | 1.062 | 26.97 | 1.219                     | 30.96 | 1.016                      | 25.81 | .128            | 3.25      | 1.210  | 30.73 | 1.260           | 32.01 |
| F (19)     | 1.156 | 29.36 | 1.297                     | 32.94 | 1.141                      | 28.98 | .128            | 3.25      | 1.335  | 33.91 | 1.385           | 35.18 |
| G (21)     | 1.250 | 31.75 | 1.422                     | 36.12 | 1.266                      | 32.16 | .128            | 3.25      | 1.460  | 37.08 | 1.510           | 38.35 |
| H (23)     | 1.375 | 34.93 | 1.547                     | 39.29 | 1.375                      | 34.93 | .154            | 3.91      | 1.585  | 40.26 | 1.635           | 41.53 |
| J (25)     | 1.500 | 38.10 | 1.672                     | 42.47 | 1.484                      | 37.69 | .154            | 3.91      | 1.710  | 43.43 | 1.760           | 44.70 |



# MIL-DTL-38999

## Contacts, Tools and Seal Plugs Series III



### Contacts, Plastic Insertion/Removal Tools and Seal Plugs

| Contact Size | Application  | Pin Contacts   | Socket Contacts | Seal Plugs      | Insertion/Removal Tools |
|--------------|--------------|----------------|-----------------|-----------------|-------------------------|
|              | Type         | Military No.   | Military No.    | Military No.    | Military No.            |
| 22D          | Power/Signal | M39029/58-360  | M39029/56-348   | MS27488-22-1    | M81969/14-01            |
| 20           | Power/Signal | M39029/58-363  | M39029/56-351   | MS27488-20-1    | M81969/14-10            |
| 16           | Power/Signal | M39029/58-364  | M39029/56-352   | MS27488-16-1    | M81969/14-03            |
| 12           | Power/Signal | M39029/58-365  | M39029/56-353   | MS27488-12-1    | M81969/14-04            |
| 12 Coax      | Coax         | M39029/28-211  | M39029/75-416   |                 |                         |
| 12 Coax      | Coax         | M39029/102-558 | M39029/103-559  |                 |                         |
| 10 (Power)   | Power        | M39029/58-528  | M39029/56-527   | M85049/81-10*** | M81969/14-05            |
| 8 Coax       | Coax         | M39029/60-367  | M39029/59-366   | MS27488-8-1     | M81969/14-06            |
| 8 Twinax     | Twinax       | M39029/90-529  | M39029/91-530   | MS27488-8-1     | M81969/14-12            |

### Crimping and Metal Insertion/Extraction Tools

| Contact Size/Type             | Crimp Tool   | Positioner                       | Positioner                          | Insertion Tool        | Extraction Tool       |
|-------------------------------|--------------|----------------------------------|-------------------------------------|-----------------------|-----------------------|
|                               | Military No. | For Pin Contacts<br>Military No. | For Socket Contacts<br>Military No. | Metal<br>Military No. | Metal<br>Military No. |
| 22D                           | M22520/2-01  | M22520/2-09                      | M22520/2-07                         | M81969/8-01           | M81969/8-02           |
| 20                            | M22520/1-01  | M22520/1-04                      | M22520/1-04                         | M81969/8-05           | M81969/8-06           |
|                               | M22520/2-01  | M22520/2-10                      | M22520/2-10                         |                       |                       |
| 16                            | M22520/1-01  | M22520/1-04                      | M22520/1-04                         | M81969/8-07           | M81969/8-08           |
| 12                            | M22520/1-01  | M22520/1-04                      | M22520/1-04                         | M81969/8-09           | M81969/8-10           |
| 12 Coax Inner                 | M22520/2-01  | M22520/2-34                      | M22520/2-34                         |                       |                       |
| 12 Coax Outer                 | M22520/31-01 | M22520/31-02                     | M22520/31-02                        |                       |                       |
| 10 ( Power)                   | 1716P-1****  | N/A                              | N/A                                 | M81969/8-11           | M81969/8-12           |
| 8 Coax Inner                  | M22520/2-01  | M22520/2-31                      | M22520/2-31                         | M81969/8-13**         | M81969/8-14           |
| 8 Coax Outer                  | M22520/5-01  | M22520/5-05<br>Die Closure B     | M22520/5-05<br>Die Closure B        |                       |                       |
| 8 Twinax Center               | M22520/2-01  | M22520/2-37                      | M22520/2-37                         | —                     | —                     |
| 8 Twinax Outer & Intermediate | M22520/5-01  | M22520/5-200                     | M22520/5-200                        |                       |                       |

### Contact and Wire Data

| Contact Size | Test Current* | Voltage*   | Crimp Well Data |                   |      | Wire Range |                 | Finished Wire Ø Range |      |         |      |
|--------------|---------------|------------|-----------------|-------------------|------|------------|-----------------|-----------------------|------|---------|------|
|              | DC Test       | Max. Drop  | Well Dia.       | Minimum Well Dept |      | AWG        | mm <sup>2</sup> | Minimum               |      | Maximum |      |
|              | Amps          | Millivolts | inch            | inch              | mm   |            |                 | inch                  | mm   | inch    | mm   |
| 22D          | 5.0           | 73         | .0345 ±.0010    | .141              | 3.58 | 28-22      | .08-.33         | .030                  | .76  | .054    | 1.37 |
| 20           | 7.5           | 55         | .047 ±.001      | .209              | 5.31 | 24-20      | .20-.52         | .040                  | 1.02 | .083    | 2.11 |
| 16           | 13.0          | 49         | .067 ±.001      | .209              | 5.31 | 20-16      | .52-1.31        | .065                  | 1.65 | .109    | 2.77 |
| 12           | 23.0          | 42         | .100 ±.002      | .209              | 5.31 | 14-12      | 2.08-3.31       | .097                  | 2.46 | .142    | 3.61 |
| 10           | 33.0          | 33         | .137 ±.003      | .355              | 9.02 | 12-10†     | 3.31-5.26       | .135                  | 3.42 | .162    | 4.12 |

† MS3348 bushing required with 12 gauge wire.

\* When tested with silver-plated wire.

\*\* Insertion tool is not required.

\*\*\* Dummy contact, used in lieu of unwired contact and seal plug.

\*\*\*\* Daniels Manufacturing part number.

**Note:** Size 8 coax contacts are used with M17/095-RG180 cable, while size 8 Twinax contacts are used with M17/176-00002 cable.



## Contact Installation Instructions

### Crimping Contacts

1. Select the appropriate crimp tool and ensure that the proper crimp head positioner is used.
2. Cycle the tool to be sure the indentors are open.
3. Determine the correct selector setting for the wire size from the data plate on the positioner (turret head assembly) and set the selector knob on the crimp tool to match.
4. Place the contact, mating end first, into the tool.
5. Insert the stripped wire into the hollow end of the contact. Be sure the wire is inserted as far as it will go.
6. Close the tool completely to crimp. Unless the tool is closed completely, the tool will not release the contact.
7. Remove the crimped contact from the tool. Check the inspection hole to verify that the wire is fully inserted.

### Insertion of Contacts

1. Before inserting the contacts, unscrew the accessories (clamps, backshells or adapters) from rear of plug or receptacle. Slide the hardware over the wire bundle in the proper order for reassembly after all the contacts are inserted.
2. To assist insertion of contacts, lubricate insulator (grommet) cavities with isopropyl alcohol. Alcohol will evaporate and will not leave a conductive film. **Caution: Never use any lubricant other than isopropyl alcohol.**

3. Place the correct insertion tool on the contact so that the wire runs along the groove in the tool. (Tool tip will butt against the shoulder.) Hold the plug or receptacle body firmly.
4. Beginning with a center cavity, insert the contact into the insulator with a slow, even pressure until the contact snaps into position. Make sure the contact and tool are held perpendicular to the face of the insert during the contact installation or the grommet could be damaged.
  - 4.1 If contacts are not inserted all the way prior to removing insertion tool, do not try to reinsert the insertion tool. Instead, remove the contact and try again; otherwise reinserting the insertion tool may damage the inside of the contact cavity.
5. Remove tool and check the face of the connector for proper contact installation. Proper installation may also be checked by pulling back lightly on the wire to make sure the contact is properly seated.

### Completion

After all the cavities have been filled, slide the hardware back into position on the connector and tighten.

### Extraction of Contacts (Rework)

1. Slide the hardware back over the wire bundle.
2. Select the appropriate tool. Place the wire into the extraction tool of the pin or socket.
3. Slowly slide the extraction tool down wire into the contact cavities until the tool tip bottoms against the contact shoulder, expanding the clip retaining tines. Hold the wire firmly in the tool and pull the wired contact and tool straight out of the rear of the insulator.

| Size | Pin Contact   | Socket Contact | Basic Crimp Tool | Pin Positioner     | Socket Positioner  | Insertion/Removal Tool |
|------|---------------|----------------|------------------|--------------------|--------------------|------------------------|
| 22D  | M39029/58-360 | M39029/56-348  | M22520/2-01      | M22520/2-09        | M22520/07          | M81969/14-01           |
| 20   | M39029/58-363 | M39029/56-351  | M22520/1-01      | M22520/1-04 Red    | M22520/1-04 red    | M81969/14-10           |
|      |               |                | M22520/2-01      | M22520/2-10        | M22520/2-10        |                        |
| 16   | M39029/58-364 | M39029/56-352  | M22520/1-01      | M22520/1-04 Blue   | M22520/1-04 Blue   | M81969/14-03           |
| 12   | M39029/58-365 | M39029/56-353  | M22520/1-01      | M22520/1-04 Yellow | M22520/1-04 Yellow | M81969/14-04           |
| 10   | M39029/58-528 | M39029/56-527  | *                | *                  | *                  | M81969/14-05           |

For Coax and Twinax contacts refer to instructions that are supplied with contacts.

\* Contact Daniels Manufacturing for crimp tool/positioner.