

The documentation and process conversion measures necessary to comply with this revision shall be completed by 21 September 2004.

INCH-POUND

MIL-PRF-19500/375G  
21 June 2004  
SUPERSEDING  
MIL-PRF-19500/375F  
19 March 2003

\* PERFORMANCE SPECIFICATION SHEET

SEMICONDUCTOR DEVICE, TRANSISTOR, FIELD-EFFECT, N-CHANNEL, DEPLETION MODE, SILICON, TYPES 2N3821, 2N3821UB, 2N3822, 2N3822UB, 2N3823, AND 2N3823UB, JAN, JANTX, JANTXV, AND JANS

This specification is approved for use by all Departments and Agencies of the Department of Defense.

\* The requirements for acquiring the product described herein shall consist of this specification sheet and MIL-PRF-19500.

1. SCOPE

1.1 Scope. This specification covers the performance requirements for N-channel, junction, silicon, field-effect depletion mode transistors. Four levels of product assurance are provided for each device type as specified in MIL-PRF-19500.

1.2 Physical dimensions. See figure 1 (similar to TO-72) and figure 2 (surface mount).

\* 1.3 Maximum ratings. Unless otherwise specified,  $T_C = +25^\circ\text{C}$ .

P <sub>T</sub> (1) T <sub>A</sub> = +25°C	V <sub>DG</sub> and V <sub>DS</sub>			V <sub>GSR</sub>			I <sub>GF</sub>	T <sub>J</sub> and T <sub>STG</sub>
	2N3821 2N3821UB	2N3822 2N3822UB	2N3823 2N3823UB	2N3821 2N3821UB	2N3822 2N3822UB	2N3823 2N3823UB		
mW	V dc	V dc	V dc	V dc	V dc	V dc	mA dc	°C
300	50	50	30	50	50	30	10	-55 to +200

(1) Derate linearly, 1.7 mW/°C for  $T_A \geq +25^\circ\text{C}$ .

\* 1.4 Primary electrical characteristics. Unless otherwise specified,  $T_C = +25^\circ\text{C}$ .

	y <sub>fs</sub>  1 (1) V <sub>DS</sub> = 15 V dc f = 1 kHz V <sub>GS</sub> = 0			y <sub>fs</sub>  3 V <sub>DS</sub> = 15 V dc, V <sub>GS</sub> = 0			C <sub>ISS</sub> V <sub>DS</sub> = 15 V dc V <sub>GS</sub> = 0 100 kHz ≤ f ≤ 1 MHz	C <sub>ISS</sub> V <sub>DS</sub> = 15 V dc V <sub>GS</sub> = 0 100 kHz ≤ f ≤ 1 MHz		
	2N3821 2N3821UB	2N3822 2N3822UB	2N3823 2N3823UB	f = 100 MHz	f = 100 MHz	f = 200 MHz		2N3821 2N3821UB	2N3822 2N3822UB	2N3823 2N3823UB
Min	μs	μs	μs	μs	μs	μs	pF	pF	pF	pF
Max	1,500	3,000	3,500	1,500	3,000	3,200	6	3	3	2
	4,500	6,500	6,500							

See note at end of 1.4.

\* Comments, suggestions, or questions on this document should be addressed to Defense Supply Center, Columbus, ATTN: DSCC-VAC, P.O. Box 3990, Columbus, OH 43218-3990, or emailed to [Semiconductor@dsc.dla.mil](mailto:Semiconductor@dsc.dla.mil). Since contact information can change, you may want to verify the currency of this address information using the ASSIST Online database at <http://www.dodssp.daps.mil/>.

\* 1.4 Primary electrical characteristics- Continued.

	$I_{DSS} (1)$ $V_{DS} = 15 \text{ V dc}$ $V_{GS} = 0$			$V_{GS(off)}$ $V_{DS} = 15 \text{ V dc}$ $I_D = 0.5 \text{ nA dc}$			$N_F$			
							$V_{DS} = 15 \text{ V dc}$ $V_{GS} = 0,$ $R_G = 1 \text{ M}\Omega$ $f = 10 \text{ Hz}$	$V_{DS} = 15 \text{ V dc}$ $V_{GS} = 0,$ $R_G = 1 \text{ M}\Omega$ $f = 1 \text{ kHz}$	$V_{DS} = 15 \text{ V dc}$ $V_{GS} = 0,$ $R_G = 1 \text{ M}\Omega$ $f = 105 \text{ MHz}$	
	2N3821 2N3821UB	2N3822 2N3822UB	2N3823 2N3823UB	2N3821 2N3821UB	2N3822 2N3822UB	2N3823 2N3823UB	2N3821 2N3821UB	2N3822 2N3822UB	All types	2N3823 2N3823UB
	<u>mA dc</u>	<u>mA dc</u>	<u>mA dc</u>	<u>V dc</u>	<u>V dc</u>	<u>V dc</u>	<u>dB</u>	<u>dB</u>	<u>dB</u>	<u>dB</u>
Min	0.5	2.0	4.0	4.0	6.0	8.0	5.0	2.5	2.5	2.5
Max	2.5	10.0	20.0							

(1) Pulsed (see 4.5.1).

2. APPLICABLE DOCUMENTS

\* 2.1 General. The documents listed in this section are specified in sections 3, 4, or 5 of this specification. This section does not include documents cited in other sections of this specification or recommended for additional information or as examples. While every effort has been made to ensure the completeness of this list, document users are cautioned that they must meet all specified requirements of documents cited in sections 3, 4, or 5 of this specification, whether or not they are listed.

2.2 Government documents.

\* 2.2.1 Specifications, standards, and handbooks. The following specifications, standards, and handbooks form a part of this document to the extent specified herein. Unless otherwise specified, the issues of these documents are those cited in the solicitation or contract.

\* DEPARTMENT OF DEFENSE SPECIFICATIONS

MIL-PRF-19500 - Semiconductor Devices, General Specification for.

\* DEPARTMENT OF DEFENSE STANDARDS

MIL-STD-750 - Test Methods for Semiconductor Devices.

\* (Copies of these documents are available online at <http://assist.daps.dla.mil/quicksearch/> or <http://www.dodssp.daps.mil/> or from the Standardization Document Order Desk, 700 Robbins Avenue, Building 4D, Philadelphia, PA 19111-5094.)

2.3 Order of precedence. In the event of a conflict between the text of this document and the references cited herein, the text of this document takes precedence. Nothing in this document, however, supersedes applicable laws and regulations unless a specific exemption has been obtained.

Ltr	Dimensions				Notes
	Inches		Millimeters		
	Min	Max	Min	Max	
CD	.178	.195	4.52	4.95	
CH	.170	.210	4.32	5.33	
HD	.209	.230	5.31	5.84	
L1		.050		1.27	
L2	.250		6.35		
LC	.100 TP		2.54 TP		
LD	.016	.021	0.41	0.53	2, 6
LL	.500	.750	12.70	19.05	6
LU	.016	.019	0.41	0.48	3, 6
Q		.040		1.02	
r		.007		0.18	
TL	.028	.048	0.71	1.22	8
TW	.036	.046	0.91	1.17	
$\alpha$	45° TP				

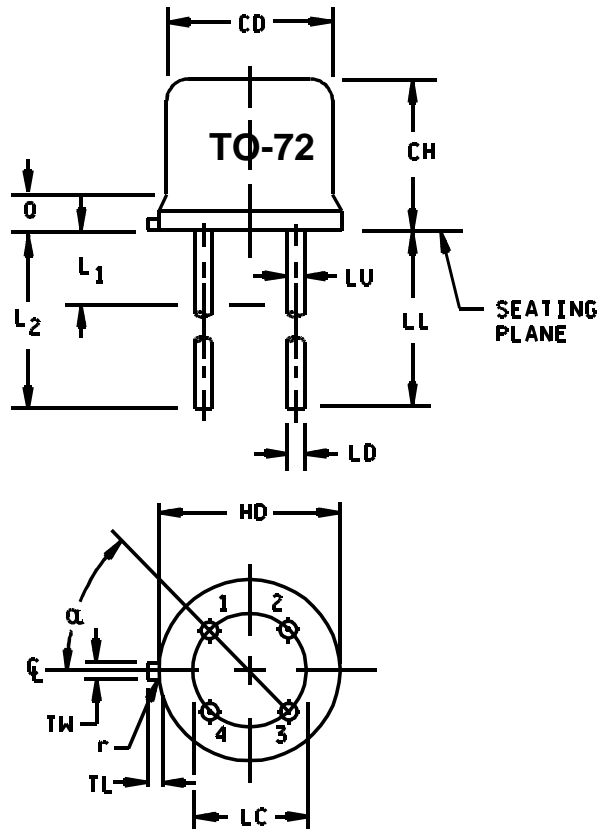

## NOTES:

- \* 1. Dimensions are in inches. Millimeters are given for general information only.
2. Measured in the zone beyond .250 (6.35 mm) from the seating plane.
3. Measured in the zone .050 (1.27 mm) and .250 (6.35 mm) from the seating plane.
4. When measured in a gauging plane .054 +.001, -.000 (1.37 +.3, -.00 mm) before the seating plane of the transistor, maximum diameter leads shall be within .007 (.18 mm) of their true location relative to a maximum width tab. Smaller diameter leads shall fall within the outline of the maximum diameter lead tolerance.
5. The active elements are electrically insulated from the case.
6. All 4 leads.
7. Lead 1 is the source, lead 2 is the drain, lead 3 is the gate, and lead 4 is the case.
8. Symbol TL is measured from HD maximum.
9. In accordance with ASME Y14.5M, diameters are equivalent to  $\phi$ x symbology.

\* FIGURE 1. Physical dimensions (similar to TO-72).

MIL-PRF-19500/375G

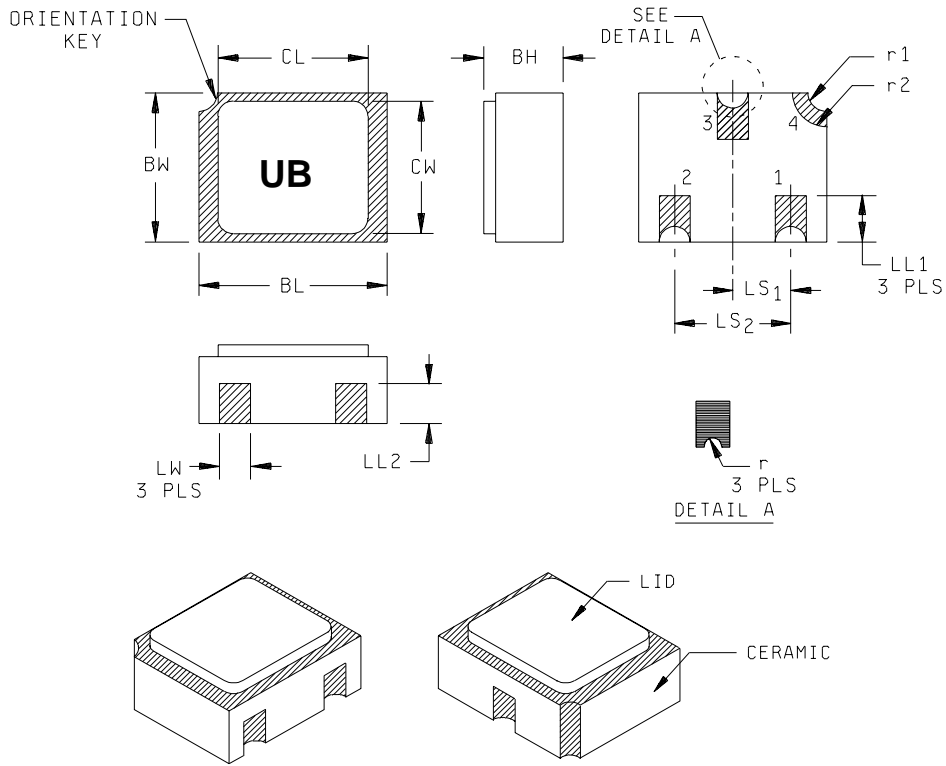

Symbol	Dimensions				Note
	Inches		Millimeters		
	Min	Max	Min	Max	
BH	.046	.056	1.17	1.42	
BL	.115	.128	2.92	3.25	
BW	.085	.108	2.16	2.74	
CL		.128		3.25	
CW		.108		2.74	
LL1	.022	.038	0.56	0.96	
LL2	.017	.035	0.43	0.89	
LS1	.036	.040	0.91	1.02	
LS2	.071	.079	1.81	2.01	
LW	.016	.024	0.41	0.61	
r		.008		.203	
r1		.012		.305	
r2		.022		.559	

NOTES:

1. Dimensions are in inches.
- \* 2. Millimeters are given for general information only.
- \* 3. Hatched areas on package denote metallized areas.
- \* 4. Lid material: Kovar.
- \* 5. Pad 1 = Drain, Pad 2 = Source, Pad 3 = Gate, Pad 4 = Shielding connected to the lid.

\* FIGURE 2. Physical dimensions, surface mount (2N3821UB, 2N3822UB, AND 2N3823UB).

### 3. REQUIREMENTS

3.1 General. The individual item requirements shall be as specified in MIL-PRF-19500 and as modified herein.

3.2 Qualification. Devices furnished under this specification shall be products that are manufactured by a manufacturer authorized by the qualifying activity for listing on the applicable qualified manufacturer's list (QML) before contract award (see 4.2 and 6.3).

3.3 Abbreviations, symbols, and definitions. Abbreviations, symbols, and definitions used herein shall be as specified in MIL-PRF-19500 and as follows.

- R<sub>ISO</sub> ..... Insulation resistance, gate lead to case.
- S ..... Unit of conductance or admittance (formerly mho).
- V<sub>1</sub> ..... rms value of the specified reference voltage in the specified circuit.
- V<sub>2</sub> ..... rms value of the measured voltage between the specified points in the specified circuit.
- |y<sub>osl</sub>| ..... Magnitude of small-signal common-source short-circuit output admittance.

\* 3.4 Interface and physical dimensions. The interface and physical dimensions shall be as specified in MIL-PRF-19500 and on figure 1 (TO-72) and figure 2 (surface mount, UB) herein.

3.4.1 Lead finish. Lead finish shall be solderable in accordance with MIL-PRF-19500, MIL-STD-750, and herein. Where a choice of lead finish is desired, it shall be specified in the acquisition document (see 6.2).

3.5 Electrical performance characteristics. Unless otherwise specified herein, the electrical performance characteristics are as specified in paragraph 1.3, 1.4, and table I.

\* 3.6 Electrical test requirements. The electrical test requirements shall be as specified in table I.

3.7 Marking. Marking shall be in accordance with MIL-PRF-19500, except for the UB suffix package. Marking on the UB package shall consist of an abbreviated part number, the date code, and the manufacturers symbol or logo. The prefixes JAN, JANTX, JANTXV, and JANS can be abbreviated as J, JX, JV, and JS respectively. The "2N" prefix and the "UB" suffix can also be omitted.

3.8 Workmanship. Semiconductor devices shall be processed in such a manner as to be uniform in quality and shall be free from other defects that will affect life, serviceability, or appearance.

### 4 VERIFICATION

\* 4.1 Classification of inspections. The inspection requirements specified herein are classified as follows:

- a. Qualification inspection (see 4.2).
- b. Screening (see 4.3).

\* c. Conformance inspection (see 4.4 and tables I and II).

\* 4.2 Qualification inspection. Qualification inspection shall be in accordance with MIL-PRF-19500 and as specified herein.

\* 4.2.1 Group E qualification. Group E inspection shall be performed for qualification or re-qualification only. In case qualification was awarded to a prior revision of the specification sheet that did not request the performance of table III tests, the tests specified in table III herein that were not performed in the prior revision shall be performed on the first inspection lot of this revision to maintain qualification.

\* 4.3 Screening (JANS, JANTX, and JANTXV levels only). Screening shall be in accordance with table IV of MIL-PRF-19500, and as specified herein. The following measurements shall be made in accordance with table I herein. Devices that exceed the limits of table I herein shall not be acceptable.

Screen (see table IV of MIL-PRF-19500)	Measurement	
	JANS level	JANTX and JANTXV levels
7	Optional.	Optional.
11	$I_{GSSR1}$ , $I_{DSS}$ , and $ y_{fs} 1$	$I_{GSSR1}$ , $I_{DSS}$ , and $ y_{fs} 1$
12	See 4.3.1	See 4.3.1
13	Subgroups 2 and 3 of table I herein; $\Delta I_{DSS} = \pm 10$ percent of initial value; $\Delta  y_{fs} 1 = \pm 20$ percent initial value.	Subgroup 2 of table I herein; $\Delta I_{DSS} = \pm 10$ percent of initial value; $\Delta  y_{fs} 1 = \pm 20$ percent of initial value.
14	Required.	Required.

4.3.1 Power burn-in conditions. Power burn-in conditions are as follows: 2N3821, 2N3821UB, 2N3822, and 2N3822UB:  $V_{GS} = 40$  V dc;  $V_{DS} = 0$ ;  $T_A = +150^\circ\text{C}$ . 2N3823, 2N3823UB:  $V_{GS} = 24$  V dc;  $V_{DS} = 0$ ;  $T_A = +150^\circ\text{C}$ . NOTE: No heat sink or forced air cooling on the devices shall be permitted.

4.4 Conformance inspection. Conformance inspection shall be in accordance with MIL-PRF-19500 and as specified herein.

4.4.1 Group A inspection. Group A inspection shall be conducted in accordance with MIL-PRF-19500, and table I herein.

4.4.2 Group B inspection. Group B inspection shall be conducted in accordance with the conditions specified for subgroup testing in tables VIa (JANS) and VIb (JAN, JANTX, and JANTXV) of MIL-PRF-19500 and 4.4.2.1 and 4.4.2.2 herein. Electrical measurements (end-points) shall be in accordance with table I, subgroup 2 herein. Delta measurements shall be in accordance with table II herein.

4.4.2.1 Group B inspection, table VIa (JANS) of MIL-PRF-19500.

Subgroup	Method	Condition
B4	1037	2N3821, 2N3821UB, 2N3822, and 2N3822UB: $V_{DS} = 30$ V dc, $V_{GS} = 0$ ; 2N3823, 2N3823UB: $V_{DS} = 15$ V dc, $V_{GS} = 0$ ; at $T_A = +30^\circ\text{C} \pm 5^\circ\text{C}$ . $t_{on} = t_{off} = 3$ minutes minimum for 2,000 cycles. No heat sink or forced-air cooling on the devices shall be permitted.
B5	1027	$V_{DS} = 0$ ; 2N3821, 2N3821UB, 2N3822, and 2N3822UB: $V_{GS} = 40$ V dc; 2N3823, 2N3823UB: $V_{GS} = 24$ V dc; at $T_A = +225^\circ\text{C}$ for 168 hours or $T_A = +200^\circ\text{C}$ for 260 hours.

4.4.2.2 Group B inspection, table VIb (JAN, JANTX, and JANTXV) of MIL-PRF-19500.

<u>Subgroup</u>	<u>Method</u>	<u>Condition</u>
B3	1027	2N3821, 2N3821UB, 2N3822, 2N3822UB, and 2N3822: $V_{GS} = 40$ V dc, $V_{DS} = 0$ ; 2N3823, 2N3823UB: $V_{DS} = 0$ , $V_{GS} = 24$ ; at $T_A = +150^\circ\text{C} \pm 5^\circ\text{C}$ .

\* 4.4.3 Group C inspection. Group C inspection shall be conducted in accordance with the conditions specified for subgroup testing in table VII of MIL-PRF-19500, and as follows. Electrical measurements (end-points) shall be in accordance with table I, subgroup 2 herein. Delta measurements shall be in accordance with table II herein.

<u>Subgroup</u>	<u>Method</u>	<u>Condition</u>
C2	2036	Test condition E (not applicable to "UB" suffix version).
* C6	1026	2N3821, 2N3821UB, 2N3822, 2N3822UB, and 2N3822: $V_{GS} = 40$ V dc, $V_{DS} = 0$ ; 2N3823, 2N3823UB: $V_{DS} = 0$ , $V_{GS} = 24$ ; at $T_A = +150^\circ\text{C} \pm 5^\circ\text{C}$ .

\* 4.4.4 Group E inspection. Group E inspection shall be conducted in accordance with the conditions specified for subgroup testing in table IX of MIL-PRF-19500 and as specified in table III herein. Electrical measurements (end-points) shall be in accordance with table I, subgroup 2 herein. Delta measurements shall be in accordance with table II herein.

4.5 Method of inspection. Methods of inspection shall be as specified in the appropriate tables and as follows.

4.5.1 Pulse measurements. Conditions for pulse measurement shall be as specified in section 4 of MIL-STD-750.

4.5.2 Disposition of case lead during electrical measurements. All electrical measurements (except for case insulation test) operating life test shall be performed with the case lead connected to the source.

4.5.2.1 Case insulation resistance test. Case insulation resistance test shall be measured between the case and gate lead.

4.5.3 Small-signal common-source short-circuit input (or output) conductance. These tests shall be conducted with a General Radio transfer function and admittance bridge model 1607A (or suitable equivalent) in accordance with the portion of its accompanying handbook which is applicable to this measurement. A Hewlett-Packard generator model 608D and a Nems-Clarke receiver model 1502A (or suitable equivalents) shall be used with the transfer function and admittance bridge.

4.5.4 10 Hz and 1 kHz spot noise figure tests. These tests shall be conducted with a model 2173C Quan Tech Laboratories test set, or equivalent. Conditions shall be as specified in table I.

4.5.5 105 MHz spot noise figure test. This test shall be conducted with the equipment and circuit shown on figures 3 and 4, or suitable equivalent.

MIL-PRF-19500/375G

TABLE I. Group A inspection.

Inspection <u>1/</u>	MIL-STD-750		Symbol	Limit		Unit
	Method	Conditions		Min	Max	
<u>Subgroup 1</u>						
Visual and mechanical examination	2071					
<u>Subgroup 2</u>						
Gate - source breakdown voltage 2N3821, 2N3821UB 2N3822, 2N3822UB 2N3823, 2N3823UB	3401	Bias condition C; $I_G = 1.0 \mu\text{A dc}$ ; $V_{DS} = 0$	$V_{(BR)GSSR}$	50 50 30		V dc V dc V dc
Gate reverse current 2N3821, 2N3821UB 2N3822, 2N3822UB 2N3823, 2N3823UB	3411	Bias condition C; $V_{GS} = 30 \text{ V dc}$ ; $V_{DS} = 0$ $V_{GS} = 30 \text{ V dc}$ ; $V_{DS} = 0$ $V_{GS} = 20 \text{ V dc}$ ; $V_{DS} = 0$	$I_{GSSR1}$		0.1 0.1 0.5	nA dc nA dc nA dc
Zero-gate-voltage drain current 2N3821, 2N3821UB 2N3822, 2N3822UB 2N3823, 2N3823UB	3413	Bias condition C; $V_{DS} = 15 \text{ V dc}$ ; $V_{GS} = 0$ ; pulsed (see 4.5.1)	$I_{DSS}$	0.5 2.0 4.0	2.5 10.0 20.0	mA dc mA dc mA dc
Gate - source voltage 2N3821, 2N3821UB 2N3822, 2N3822UB 2N3823, 2N3823UB	3403	$V_{DS} = 15 \text{ V dc}$ ; $I_D = 50 \mu\text{A dc}$ $I_D = 200 \mu\text{A dc}$ $I_D = 400 \mu\text{A dc}$	$V_{GS}$	0.5 1.0 1.0	2.0 4.0 7.5	V dc V dc V dc
Gate - source cutoff voltage 2N3821, 2N3821UB 2N3822, 2N3822UB 2N3823, 2N3823UB	3403	$V_{DS} = 15 \text{ V dc}$ ; $I_D = 0.5 \text{ nA dc}$	$V_{GS(off)}$		4.0 6.0 8.0	V dc V dc V dc
Case insulation resistance	1016	Test condition A; (see 4.5.2.1)	$R_{ISO}$	$10^{10}$		$\Omega$
Small-signal, common- source, short-circuit, forward transadmittance 2N3821, 2N3821UB 2N3822, 2N3822UB 2N3823, 2N3823UB	3455	$V_{DS} = 15 \text{ V dc}$ ; $V_{GS} = 0$ ; $f = 1 \text{ kHz}$ ; pulsed (see 4.5.1)	$ y_{fs} 1$	1,500 3,000 3,500	4,500 6,500 6,500	$\mu\text{S}$ $\mu\text{S}$ $\mu\text{S}$
<u>Subgroup 3</u>						
High-temperature operation:		$T_A = +150^\circ\text{C}$				
Gate reverse current 2N3821, 2N3821UB 2N3822, 2N3822UB 2N3823, 2N3823UB	3411	Bias condition C; $V_{GS} = 30 \text{ V dc}$ ; $V_{DS} = 0$ $V_{GS} = 30 \text{ V dc}$ ; $V_{DS} = 0$ $V_{GS} = 20 \text{ V dc}$ ; $V_{DS} = 0$	$I_{GSSR2}$		0.1 0.1 0.5	$\mu\text{A dc}$ $\mu\text{A dc}$ $\mu\text{A dc}$

See footnotes at end of table.



TABLE I. Group A inspection - Continued.

Inspection <u>1/</u>	MIL-STD-750		Symbol	Limit		Unit
	Method	Conditions		Min	Max	
<u>Subgroup 3</u> - Continued						
Low-temperature operation:						
$T_A = -55^\circ\text{C}$						
Small-signal, common-source, short-circuit, forward transadmittance 2N3821, 2N3821UB 2N3822, 2N3822UB 2N3823, 2N3823UB	3455	$V_{DS} = 15\text{ V dc}; V_{GS} = 0;$ $f = 1\text{ kHz};$ pulsed (see 4.5.1)	$ y_{fs} _2$		6,750 9,750 9,750	$\mu\text{S}$ $\mu\text{S}$ $\mu\text{S}$
<u>Subgroup 4</u>						
Small-signal common-source, short-circuit, output admittance 2N3821, 2N3821UB 2N3822, 2N3822UB 2N3823, 2N3823UB	3453	$V_{DS} = 15\text{ V dc}; V_{GS} = 0;$ $f = 1\text{ kHz};$ pulsed (see 4.5.1)	$ y_{os} $		10 20 35	$\mu\text{S}$ $\mu\text{S}$ $\mu\text{S}$
Small-signal common-source, short-circuit, input capacitance	3431	$V_{DS} = 15\text{ V dc}; V_{GS} = 0;$ $100\text{ kHz} \leq f \leq 1\text{ MHz}$	$C_{iss}$		6	pF
Small-signal common-source, short-circuit, reverse-transfer capacitance 2N3821, 2N3821UB, 2N3822, 2N3822UB 2N3823, 2N3823UB	3453	$V_{DS} = 15\text{ V dc}; V_{GS} = 0;$ $100\text{ kHz} \leq f \leq 1\text{ MHz}$	$C_{rss}$		3 2	pF pF
Small-signal common-source, short-circuit, forward transadmittance 2N3821, 2N3821UB 2N3822, 2N3822UB 2N3823, 2N3823UB	3455	$V_{DS} = 15\text{ V dc}; V_{GS} = 0$  $f = 100\text{ MHz}$ $f = 100\text{ MHz}$ $f = 200\text{ MHz}$	$ y_{fs} _3$		1,500 3,000 3,200	$\mu\text{S}$ $\mu\text{S}$ $\mu\text{S}$
Small-signal common-source, short-circuit, input conductance 2N3823 and 2N3823UB only		$V_{DS} = 15\text{ V dc}; V_{GS} = 0; f = 200\text{ MHz};$ (see 4.5.3)	$g_{is}$		800	$\mu\text{S}$

See footnotes at end of table.

MIL-PRF-19500/375G

TABLE I. Group A inspection - Continued.

Inspection <u>1/</u>	MIL-STD-750		Symbol	Limit		Unit
	Method	Conditions		Min	Max	
<u>Subgroup 4</u> - Continued						
Small-signal common-source, short-circuit, output conductance 2N3823 and 2N3823UB only		$V_{DS} = 15 \text{ V dc}; V_{GS} = 0;$ $f = 200 \text{ MHz};$ (see 4.5.3)	$g_{os}$		200	$\mu\text{S}$
Common-source spot noise figure  2N3821, 2N3821UB, and 2N3822, 2N3822UB only All types		$V_{DS} = 15 \text{ V dc}; V_{GS} = 0;$ $R_G = 1 \text{ M}\Omega;$ (see 4.5.4)  $f = 10 \text{ Hz}$  $f = 1 \text{ kHz}$	$NF_1$		5.0	dB
Common-source spot noise figure  2N3823, 2N3823UB only		$V_{DS} = 15 \text{ V dc}; V_{GS} = 0;$ $R_G = 1 \text{ k}\Omega; f = 105 \text{ MHz};$ (see 4.5.5)	$NF_2$		2.5	dB
<u>Subgroups 5, 6, and 7</u>						
Not applicable						

1/ For sampling plan, see MIL-PRF-19500.

MIL-PRF-19500/375G

\* TABLE II. Groups B, C, and E delta measurements. 1/ 2/ 3/ 4/

Step	Inspection	MIL-STD-750		Symbol	Limit	Unit
		Method	Conditions			
1.	Gate - source voltage  2N3821, 2N3821UB 2N3822, 2N3822UB 2N3823, 2N3823UB	3403	$V_{DS} = 15 \text{ V dc}$  $I_D = 50 \mu\text{A dc}$ $I_D = 200 \mu\text{A dc}$ $I_D = 400 \mu\text{A dc}$	$\Delta V_{GS}$	$\pm 50 \text{ mV change from previously measured value}$	
2.	Zero-gate-voltage drain current	3413	Bias condition C; $V_{DS} = 15 \text{ V dc}$ ; $V_{GS} = 0$ ; pulsed (see 4.5.1)	$\Delta I_{DSS}$	$\pm 15 \text{ percent change from previously measured value.}$	
3.	Small-signal, common-source short-circuit, forward transadmittance	3455	$V_{DS} = 15 \text{ V dc}$ ; $V_{GS} = 0$ ; $f = 1 \text{ kHz}$ ; pulsed (see 4.5.1)	$\Delta  y_{fs} _1$	$\pm 25 \text{ percent change from previously measured value.}$	

1/ The delta measurements for table VIa (JANS) of MIL-PRF-19500 are as follows:

- a. Subgroup 3, see table II herein, steps 2 and 3.
- b. Subgroup 4, see table II herein, steps 1, 2, and 3.
- c. Subgroup 5, see table II herein, steps 2 and 3.

2/ The delta measurements for table VIb (JAN, JANTX, and JANTXV) of MIL-PRF-19500 are as follows:

Subgroup 3, see table II herein, step 3.

3/ The delta measurements for table VII of MIL-PRF-19500 are as follows:

- a. Subgroups 2 and 3, table II herein, steps 1, 2, and 3 (for JANS only).
- b. Subgroup 6, see table II herein, steps 1, 2, and 3, (for JANS) and step 3 (for JAN, JANTX, and JANTXV).

\* 4/ The delta measurements for table IX of MIL-PRF-19500 are: Subgroups 1 and 2, see table II herein, all steps.

MIL-PRF-19500/375G

\* TABLE III. Group E inspection (all quality levels) for qualification or re-qualification only.

Inspection	MIL-STD-750		Qualification and large lot quality conformance inspection
	Method	Conditions	
<u>Subgroup 1</u>			12 devices c = 0
Temperature cycling	1051	-55°C to +150°C, 500 cycles	
Hermetic seal	1071	Test conditions G or H	
Fine leak		Test conditions C or D	
Gross leak			
Electrical measurements		See table I, subgroup 2 and table II, all steps	
<u>Subgroup 2 1/</u>			12 devices c = 0
Steady-state operating life	1026	V <sub>DS</sub> = 0; 2N3821, 2N3821UB, 2N3822, and 2N3822UB: V <sub>GS</sub> = 40 V dc; 2N3823, 2N3823UB: V <sub>GS</sub> = 24 V dc; at T <sub>A</sub> = +225°C for 168 hours or T <sub>A</sub> = +200°C for 260 hours.	
Electrical measurements		See table I, subgroup 2 and table II, all steps	
<u>Subgroup 3</u>			3 devices c = 0
DPA	2102		
<u>Subgroup 4</u>			Sample size N/A
Thermal impedance curves		Each supplier shall submit their qual-lot average and design maximum thermal impedance curves. In addition, the optimal test conditions and Z <sub>θJX</sub> limit shall be provided to the qualifying activity in the qualification report	
<u>Subgroup 5</u>			
Not applicable			
<u>Subgroup 6</u>			3 devices
ESD	1020		
<u>Subgroup 7</u>			45 devices c = 0
Reverse stability	1033	Condition A	

1/ A separate sample for each test shall be pulled.

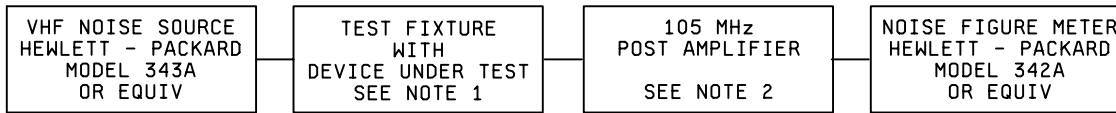

## NOTES:

1. The test fixture and procedure shall be in accordance with figure 4.
2. The post amplifier shall contain suitable biasing circuits and shall be constructed utilizing very high frequency design technique.

\* FIGURE 3. Block diagram for 105 MHz spot noise figure test.

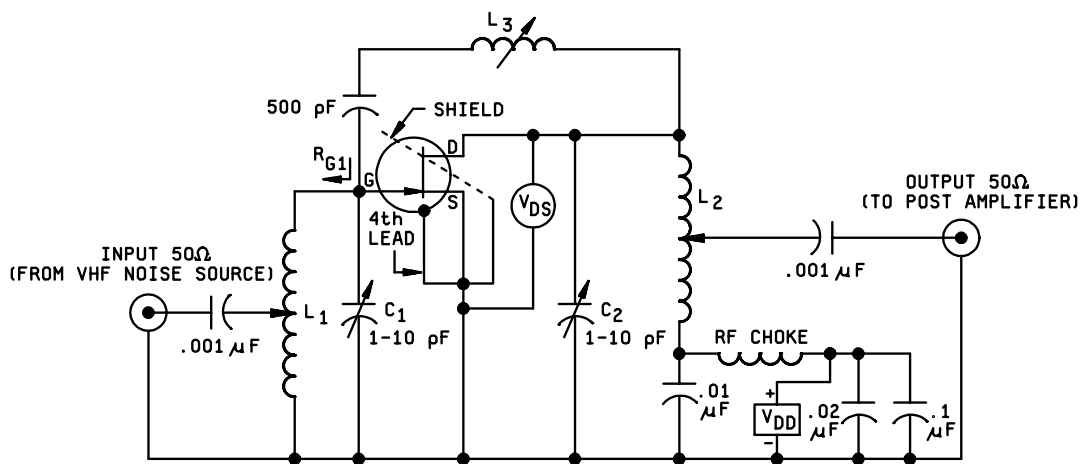
CIRCUIT-COMPONENT INFORMATION:

- L<sub>1</sub>: Approximately 8.5 turns of No. 16 tinned copper; diameter approximately .375 inch (9.52 mm); length approximately .9 inch (22.8 mm); tapped at approximately 2.5 turns (adjust to give R<sub>G1</sub> = 100 Ω); parallel resistance = 40 kΩ; tunes at approximately 8 pF.
- L<sub>2</sub>: Approximately 13.5 turns of No. 16 tinned copper; diameter approximately .375 inch; length approximately 1.2 inches (30.5 mm); tapped at approximately 5 turns; parallel resistance = 40 kΩ; tunes at approximately 4 pF.
- L<sub>3</sub>: Approximately 15 turns of No. 20 tinned copper.

TEST PROCEDURE:

1. Neutralization shall be accomplished as follows:
  - a. Insert a typical device from the units to be tested.
  - b. Using a sweep generator and an oscilloscope adjust the input (C<sub>1</sub>) and output (C<sub>2</sub>) for maximum gain at 105 MHz.
  - c. Reverse the input and output of the test jig and tune L<sub>3</sub> for a null.
  - d. Return the input and output of the test jig to normal.
2. Once neutralization has been obtained, the devices may be tested by inserting them in the test jig and adjusting C<sub>1</sub> and C<sub>2</sub> to obtain minimum noise figure for each device.

FIGURE 4. 105 MHz spot noise figure test fixture.

## 5. PACKAGING

\* 5.1 Packaging. For acquisition purposes, the packaging requirements shall be as specified in the contract or order (see 6.2). When actual packaging of materiel is to be performed by DoD or in-house contractor personnel, these personnel need to contact the responsible packaging activity to ascertain packaging requirements. Packaging requirements are maintained by the Inventory Control Point's packaging activities within the Military Service or Defense Agency, or within the Military Service's system commands. Packaging data retrieval is available from the managing Military Department's or Defense Agency's automated packaging files, CD-ROM products, or by contacting the responsible packaging activity.

## 6 NOTES

(This section contains information of a general or explanatory nature that may be helpful, but is not mandatory.)

6.1 Intended use. The notes specified in MIL-PRF-19500 are applicable to this specification.

\* 6.2 Acquisition requirements. Acquisition documents should specify the following:

- a. Title, number, and date of this specification.
- b. Packaging requirements (see 5.1).
- c. Lead finish (see 3.4.1).
- d. Product assurance level and type designator.

6.3 Qualification. With respect to products requiring qualification, awards will be made only for products which are, at the time of award of contract, qualified for inclusion in Qualified Manufacturers List (QML 19500) whether or not such products have actually been so listed by that date. The attention of the contractors is called to these requirements, and manufacturers are urged to arrange to have the products that they propose to offer to the Federal Government tested for qualification in order that they may be eligible to be awarded contracts or orders for the products covered by this specification. Information pertaining to qualification of products may be obtained from Defense Supply Center, Columbus, ATTN: DSCC/VQE, P.O. Box 3990, Columbus, OH 43218-3990 or e-mail [vqe.chief@dla.mil](mailto:vqe.chief@dla.mil).

6.4 Changes from previous issue. The margins of this specification are marked with asterisks to indicate where changes from the previous issue were made. This was done as a convenience only and the Government assumes no liability whatsoever for any inaccuracies in these notations. Bidders and contractors are cautioned to evaluate the requirements of this document based on the entire content irrespective of the marginal notations and relationship to the last previous issue.

Custodians:  
Army - CR  
Navy - EC  
Air Force - 11  
NASA - NA  
DLA - CC

Preparing activity:  
DLA - CC

(Project 5961-2898)

Review activities:  
Army - AR, AV, SM  
Navy - AS, MC  
Air Force - 19

\* NOTE: The activities listed above were interested in this document as of the date of this document. Since organizations and responsibilities can change, you should verify the currency of the information above using the ASSIST Online database at <http://www.dodssp.daps.mil/>.