

User's Manual

78K0/IB2

Fluorescent Ballast Evaluation Board

Target Device

78K0/IB2 Microcontroller

ZBB-CE-09-0011-E

Data Published March 2009

© NEC Electronics Corporation

- The information in this document is current as of March, 2009. The information is subject to change without notice. For actual design-in, refer to the latest publications of NEC Electronics data sheets or data books, etc., for the most up-to-date specifications of NEC Electronics products. Not all products and/or types are available in every country. Please check with an NEC Electronics sales representative for availability and additional information.
- No part of this document may be copied or reproduced in any form or by any means without the prior written consent of NEC Electronics. NEC Electronics assumes no responsibility for any errors that may appear in this document.
- NEC Electronics does not assume any liability for infringement of patents, copyrights or other intellectual property rights of third parties by or arising from the use of NEC Electronics products listed in this document or any other liability arising from the use of such products. No license, express, implied or otherwise, is granted under any patents, copyrights or other intellectual property rights of NEC Electronics or others.
- Descriptions of circuits, software and other related information in this document are provided for illustrative purposes in semiconductor product operation and application examples. The incorporation of these circuits, software and information in the design of a customer's equipment shall be done under the full responsibility of the customer. NEC Electronics assumes no responsibility for any losses incurred by customers or third parties arising from the use of these circuits, software and information.
- While NEC Electronics endeavors to enhance the quality, reliability and safety of NEC Electronics products, customers agree and acknowledge that the possibility of defects thereof cannot be eliminated entirely. To minimize risks of damage to property or injury (including death) to persons arising from defects in NEC Electronics products, customers must incorporate sufficient safety measures in their design, such as redundancy, fire-containment and anti-failure features.
- NEC Electronics products are classified into the following three quality grades: "Standard", "Special" and "Specific".

The "Specific" quality grade applies only to NEC Electronics products developed based on a customer-designated "quality assurance program" for a specific application. The recommended applications of an NEC Electronics product depend on its quality grade, as indicated below. Customers must check the quality grade of each NEC Electronics product before using it in a particular application.

"Standard": Computers, office equipment, communications equipment, test and measurement equipment, audio and visual equipment, home electronic appliances, machine tools, personal electronic equipment and industrial robots.

"Special": Transportation equipment (automobiles, trains, ships, etc.), traffic control systems, anti-disaster systems, anti-crime systems, safety equipment and medical equipment (not specifically designed for life support).

"Specific": Aircraft, aerospace equipment, submersible repeaters, nuclear reactor control systems, life support systems and medical equipment for life support, etc.

- The quality grade of NEC Electronics products is "Standard" unless otherwise expressly specified in NEC Electronics data sheets or data books, etc. If customers wish to use NEC Electronics products in applications not intended by NEC Electronics, they must contact an NEC Electronics sales representative in advance to determine NEC Electronics' willingness to support a given application.

(Note)

- (1) "NEC Electronics" as used in this statement means NEC Electronics Corporation and also includes its majority-owned subsidiaries.
- (2) "NEC Electronics products" means any product developed or manufactured by or for NEC Electronics (as defined above).

Safety Precautions



This document explains matters to be noted for safe use of this evaluation board. Be sure to read this document before using this evaluation board.

- Be sure to observe all dangers, warnings, cautions, and other instructions contained herein when using this evaluation board.
- This document should be kept handy at all times for ready reference.







Symbols used

This document used the following symbols for matters to be observed for the safe use of the unit.

The symbols are followed by a brief explanation of the possible extent of problems which may occur if the notices are not observed.

 Danger	The user may suffer death or serious injury and it's risk is high if the warning is not observed.
 Warning	The user may suffer death or serious injury if the warning is not observed.
 Caution	Human injury or property damage may occur if the caution is not observed.

The following symbols express matters which are prohibited in order to prevent injury or accident.

 General prohibition The action mentioned is prohibited.	 Do not touch Touching the specified location may cause injury.	 Do not disassemble Disassembly may cause a problem such as electrical shock or product failure.
 Keep away from water Use near water poses the risk of electrical shock or product failure if moisture were to contact the unit.	 Flammable A nearby flame may cause the unit to catch fire.	 Do not touch with wet hands Touching with wet hands may cause electric shock or product failure.













The following symbols are used for cautions to prevent product failure and accidents.

 General caution Unspecified general cautions.	 Caution Hot Human injury by high temperature may occur.
---	---

The following symbols are used for instructions to prevent product failure and accidents.

 Compulsory action based on an instruction for the user.	 Instruction to unplug from AC power supply.
---	---

Warnings

 Danger	
	<p>Do not use this board in the purpose except the evaluation of MCU. This board does not take safety measures or anti-EMI measures required for lighting equipment.</p>
	<p>Do not touch to the high voltage area of the board. Touching the board by tools or body while power is being supplied cause product failure or electric shock.</p>
	<p>Do not touch with wet hands. Doing so cause product failure or electrical shock.</p>
	<p>Do not use or store this board in any of the following locations.</p> <ul style="list-style-type: none"> - Environments with copious water, humidity, steam, dust, fumes, etc. - Environments where static electricity or electrical noise is readily generated. <p>Such influences can lead to electric shock or product failure.</p>
	<ul style="list-style-type: none"> - Use glove to protect electric shock. - Limit the user of this board.
 Warning	
	<p>Be careful to burns. The part of board becomes high temperature during AC power is connected.</p>
	<p>Do not disassemble or modify the board. Doing so may cause product failure, emission of smoke, fire, or electric shock.</p>
	<p>Do not heat the board or expose it to fire, and do not short the terminals. Doing so may cause product failure, generation of heat, fire, or rupture.</p>
	<p>Do not drop or jolt the board. Doing so may break or damage the board, causing fire or electric shock.</p>
	<p>Use AC power supply in the range of AC100[V]~240[V](50[Hz]/60[Hz]). Using AC power supply out of this range may cause product failure, generation of heat, fire, or electric shock.</p>
	<p>Do not plug in or unplug a connector or cable with power applied to the board. Doing so may cause product failure, generation of heat, fire or rupture.</p>
	<p>Do not turn on power switch in insufficient state of cable connection such as AC power, fluorescent lamp connection cable, and communication cable. Doing so may cause product failure, generation of heat, fire or electric shock.</p>
	<p>Do not carry this board with connecting any cable. Doing so may cause damage of cable and cause product failure, generation of heat, fire or electric shock.</p>
	<p>Use AC power supply cable and plug adapted to safety standard of each country with more than 5A rating. Using non-adopt cable or plug cause product failure, generation of heat, fire or electric shock.</p>



Warning



Use this board with spacer and on the isolated bench.

In case conductor contact to the board, it may cause product failure, generation of heat, fire or electric shock.

Confirm the outlet is near this board and easily unplugged.



If smoke or an abnormal smell or sound is emitted, or heating occurs, promptly switch off the board power and unplug from AC power supply.

Using the board in such a state poses a risk of fire, burning, or electric shock.

Cautions



Caution



To prevent static electricity damage, guard against energizing when touching metal parts such as the connector.

Static electricity can cause product failure.



To prevent collisions of the board with the fluorescent lamp connection cable, remove 1 middle cable in the 5 cables if you use the ones.

Static electricity can cause product failure.

CONTENTS

CHAPTER 1 OVERVIEW 7

CHAPTER 2 SPECIFICATION 9

CHAPTER 3 OPERATION 12

APPENDIX A SCHEMATICS 20

APPENDIX B BILL OF MATERIALS 21

APPENDIX C REVISION HISTORY 24

1. Overview

78K0/IB2 Fluorescent Ballast Evaluation Board is an evaluation kit for fluorescent ballast control by using 78K0/IB2 microcontroller.

This board can operate by AC100[V]~240[V](50[Hz]/60[Hz]) power supply.

78K0/IB2 controls PFC, Inverter which is required for fluorescent ballast control.

When connecting with Lighting Communication Master Evaluation Board(EZ-0008), it can be controlled to dim with DALI protocol or IR remote.

Figure 1. System Outline

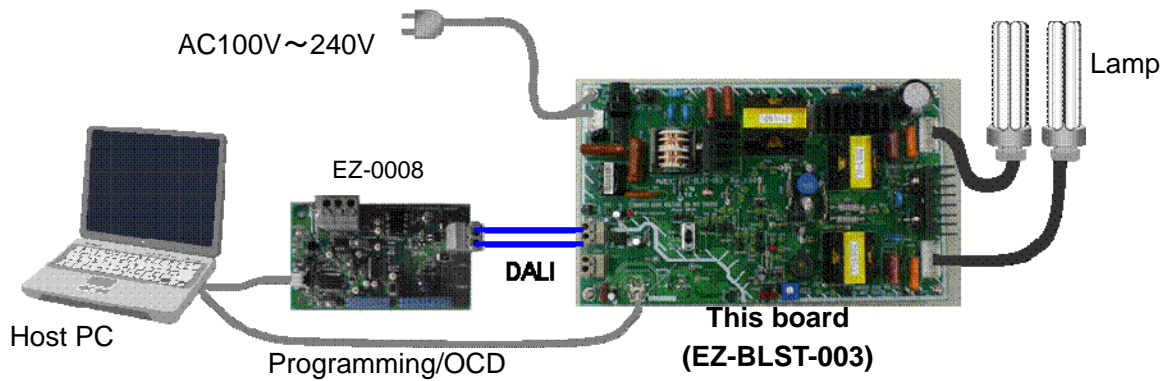

1.1 Feature

- PFC control and Inverter control by 78K0/IB2 microcontroller
 - PFC control by PWM timer interlocked with internal comparator
 - Half-Bridge inverter control output with dead-time
 - Support input voltage range : AC100[V]~240[V](50[Hz]/60[Hz])
 - Buzzer output
- Up to 3 kind of control interface supported
 - DALI protocol communication interface
 - IR remote signal receive interface
 - Analog volume control interface
- Programming / On-chip debug supported

1.2 Operation Mode

- RUN mode
Three control interfaces are offered on this board.
 - DALI protocol control interface
 - IR remote signal receive interface
 - Analog volume control interface
- Programming mode
Flash programming through the USB interface
- On-chip debug mode
On-chip debug through the USB interface.

1.3 Related product information

As for the information of related products for this board, please refer NEC Electronics Web site.

URL <http://www.necel.com/micro/en/solution/lighting/index.html>



2. Specification

This chapter described the specification of 78K0/IB2 Fluorescent Ballast Evaluation Board.

2.1 Appearance of the board

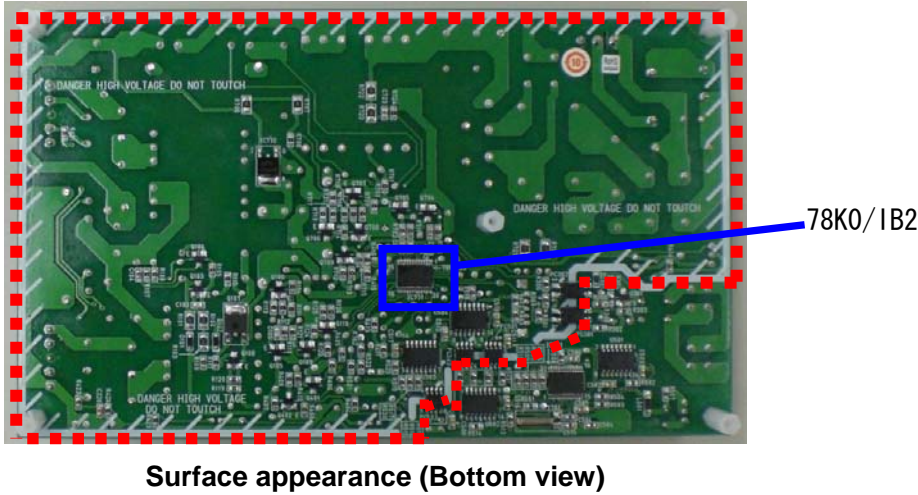
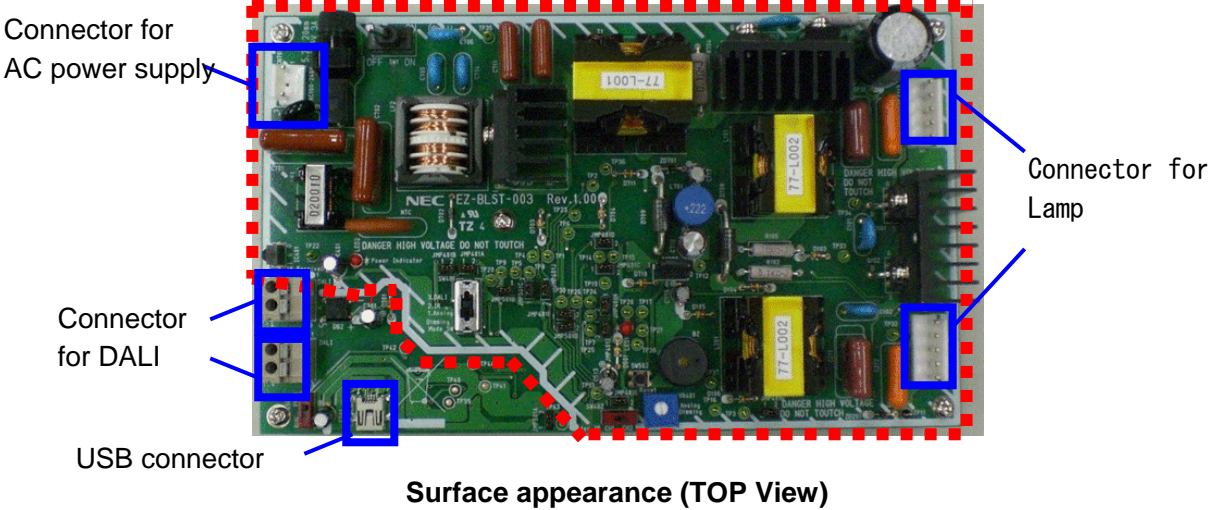
Figure 2. Appearance of 78K0/IB2 Fluorescent Ballast Evaluation Board



 Danger	
	<p>Do not touch the area enclosed with RED line because of high voltage while power is being supplied. This area is also indicated by white heavy line on the board.</p>
	<p>Use this board with spacer and on the isolated bench. In case conductor contact to the board, it may cause product failure, generation of heat, fire or electric shock.</p>

2.2 Detail specification

Board name : EZ-BLST-003
Power supply : AC100[V]~240[V](50[Hz]/60[Hz])
Microcontroller : 78K0/IB2 (UPD78F0756MC-CAB-AX)
PFC control circuit (controlled by 78K0/IB2)
Half-bridge inverter control circuit (controlled by 78K0/IB2)
USB interface (for programming / On-chip debug)
DALI interface circuit
IR remote signal receive circuit
Analog volume
Buzzer output circuit
LED output circuit

2.3 Components which need to prepare by yourself

Power supply plug and cable : please prepare following components

Rated current : more than 5[A]
Plug : match to the specification for each country

Lamp and socket

Lamp : Type: FHT42 (Compact fluorescent lamp) x 2
Socket : Type: GX24q-4 x 2



Warning



Use power supply plug and cable with more than 5[A] current rating, and adapted to safety standard of each country.

Using non-adopt cable or plug cause product failure, generation of heat, fire or electric shock.

Please refer Appendix A for circuit diagram of 78K0/IB2 Fluorescent Ballast Evaluation Board

2.4 Switch setting and Connector pin assignment

Table 1. Power supply switch (SW1) setting

	ON	OFF
SW1	Power supply ON	Power supply OFF

Table 2. Control interface select switch (SW401) setting

Position	Control mode
1. Analog	Analog volume control
2. IR	IR remote receive control
3. DALI	DALI protocol control

Table 3. IR remote control channel select switch(SW402) setting

Position	IR remote control channel
“CH1” side	Channel 1
“CH2” side	Channel 2

Sample program provided from NEC Electronics is using “NEC format” with custom code:0000h.

Receive data for each channel is using following data.

Channel 1 : Data=5Ah, Reverse Data=A5h

Channel 2 : Data=DAh, Reverse Data=25h

Table 4. Microcontroller operation mode select switch (SW501) setting

Position	MCU operation mode
“RUN” side	Run mode
“PROG” side	Programming mode / On-chip debug mode

Table 5. Other switch

	Description
SW501	Reset switch

Figure 3. Pin assignment of Lamp connector(CN101, CN201)

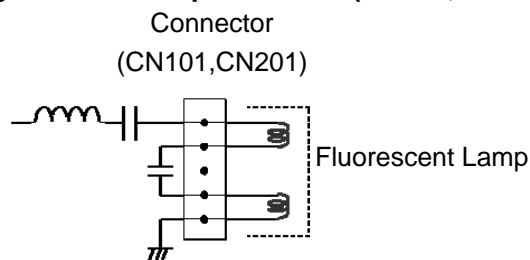

Caution



To prevent collisions of the board with the fluorescent lamp connection cable, remove 1 middle cable in the 5 cables if you use the ones.
Static electricity can cause product failure.

3. Operation

3.1 Before using

3.1.1 Driver Installation

Install driver when connecting this board to PC by using USB cable for the first time.

- ① Download driver from following URL.
URL <http://www.necel.com/micro/en/solution/lighting/download.html>
- ② When connecting this board to PC by using USB cable, "Found New Hardware Wizard" dialog box is displayed.
Select "Yes, now and every time I connect a device", and click [Next].
- ③ Select "Install from a list or specific location (Advanced)", and click [Next].
- ④ Select "Include this location in the search" and then click [Browse]
Specify the folder to which download files are saved, and click [Next]
- ⑤ Installation starts
Click [Continue Anyway] in case "Hardware Installation" dialog is displayed.
- ⑥ Click [Finish]. Installation is complete.

3.1.2 Programmer Installation

Please install the programmer for 78K0/IB2 flash programming.

- ① Download programming software "WriteEZ3" and related parameter file from following URL.
URL <http://www.necel.com/micro/en/solution/lighting/download.html>
- ② Decompress the downloaded file.

3.1.3 On-chip debugger and compiler Installation

Please install On-chip debugger and compiler if on-chip debug mode of this board is required to be used.

- ① Download integrated debugger "ID78K0-QB", NEC Electronics development tools "PM+", "RA78K0", "CC78K0", and device file for the target device 78K0/IB2 microcontroller.
URL <http://www.necel.com/micro/en/solution/lighting/download.html>
- ② Install "RA78K0". Project manager "PM+" will be installed automatically.
- ③ Install "CC78K0"
- ④ Install device file
- ⑤ Install "ID78K0-QB"

3.1.4 DALI GUI Installation

To control this board by DALI protocol, NEC Electronics offers “Lighting communication master evaluation board (EZ-0008)” and GUI for easy evaluation.

About “Lighting communication master evaluation board (EZ-0008)”, please refer “Lighting Communication Master Evaluation Board (EZ-0008) Quick Start Guide (ZED-CE-09-0018).

- ① Download DALI GUI from following URL.

URL <http://www.necel.com/micro/en/solution/lighting/download.html>

- ② Install DALI GUI

For detail, please refer “DALI master controller GUI User’s Manual (U19607EJ1V1UM00)”

3.1.5 Sample Program

NEC Electronics offers sample program of 78K0/IB2 to control Fluorescent ballast by this board. Please download sample program from following URL for reference.

URL <http://www.necel.com/micro/en/solution/lighting/download.html>

3.2 Programming mode





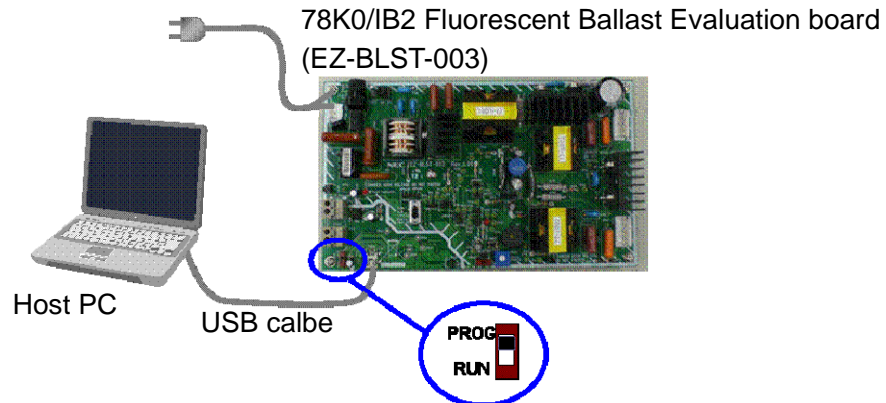

3.2.1 Start Programming

- ① Connect this board to PC by using USB cable.
- ② Set SW501 to “PROG” side.
- ③ Provide AC power supply to this board, and turn on power supply switch (SW1).

Figure 4. Connection when programming to 78K0/IB2



- ④ Start up “WriteEZ3”
- ⑤ Click [Setup] to open the device setup dialog box.
Select parameter file 78F0756.prm
Specify the COM port for communication between host PC and this board.
- ⑥ Click [Load] to select the hex file which is expected to be programmed.
- ⑦ Click [Autoprocedure] to do flash programming.
- ⑧ Close “WriteEZ3”
- ⑨ Turn off power supply switch “SW1”, and disconnect USB cable.

 Danger	
	Do not touch to the high voltage area of the board. Touching the board by tools or body while power is being supplied cause product failure or electric shock.
	Do not touch with wet hands. Doing so cause product failure or electrical shock.
	Do not turn on power switch in insufficient state of cable connection such as AC power, fluorescent lamp connection cable, and communication cable. Doing so may cause product failure, generation of heat, fire or electric shock.
	Use this board with spacer and on the isolated bench. In case conductor contact to the board, it may cause product failure, generation of heat, fire or electric shock.
	Confirm the outlet is near this board and easily unplugged.
	If smoke or an abnormal smell or sound is emitted, or heating occurs, promptly switch off the board power and unplug from AC power supply. Using the board in such a state poses a risk of fire, burning, or electric shock.

3.3 RUN mode

This chapter describe about operation by using sample program offered NEC Electronics. Please download sample program from following URL.

URL : <http://www.necel.com/micro/en/solution/lighting/download.html>

Please refer **3.2 Programming mode** for programming





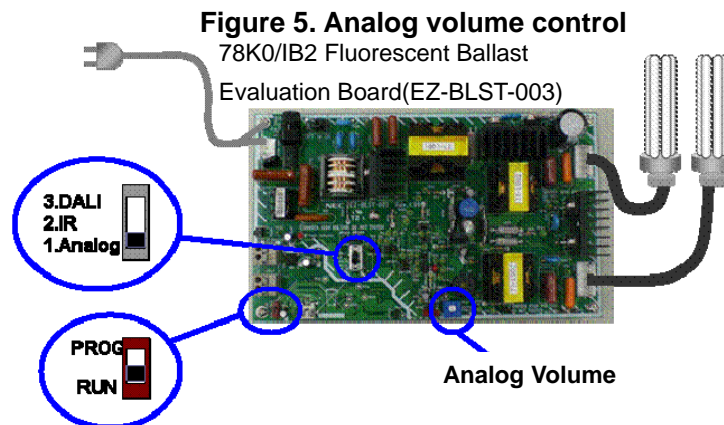

3.3.1 Analog Volume control

Analog volume is connected to P70/ANI8 of 78k0/IB2 microcontroller on this board. It is possible to do dimming control by changing analog input voltage.

- ① Connect Fluorescent Lamp
- ② Set SW501 to "RUN" side.
- ③ Set SW401 to "1.Analog" position
- ④ Provide AC power supply to this board, and turn on power supply switch (SW1).



- ⑤ Dimming control is possible by changing analog volume.
- ⑥ Turn off power supply switch "SW1".

 Danger	
	Do not touch to the high voltage area of the board. Touching the board by tools or body while power is being supplied cause product failure or electric shock.
	Do not touch with wet hands. Doing so cause product failure or electrical shock.
	Do not turn on power switch in insufficient state of cable connection such as AC power, fluorescent lamp connection cable, and communication cable. Doing so may cause product failure, generation of heat, fire or electric shock.
	Use this board with spacer and on the isolated bench. In case conductor contact to the board, it may cause product failure, generation of heat, fire or electric shock.
	Confirm the outlet is near this board and easily unplugged.
	If smoke or an abnormal smell or sound is emitted, or heating occurs, promptly switch off the board power and unplug from AC power supply. Using the board in such a state poses a risk of fire, burning, or electric shock.

3.3.2 IR Remote control

IR remote receive signal is connected to P00/TI000/INTP0 of 78k0/IB2 microcontroller on this board. By using pulse width measurement function of 16bit timer/event counter00, it is possible to receive IR remote signal and do dimming control.





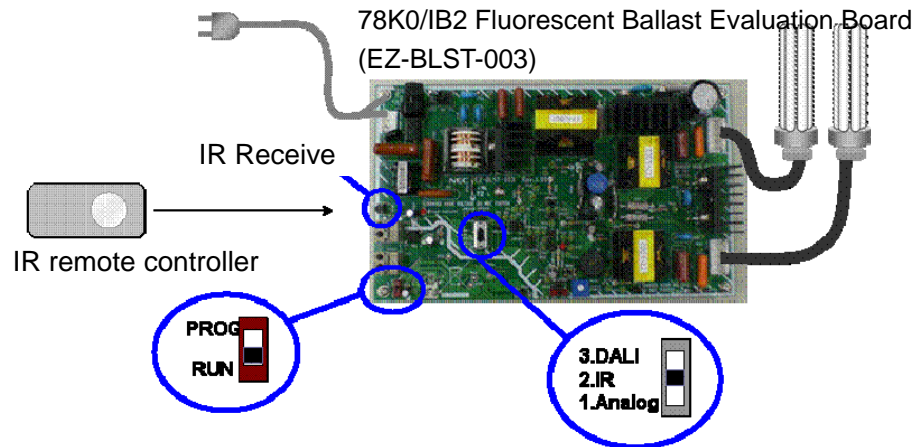

- ① Connect Fluorescent Lamp
- ② Set SW501 to "RUN" side.
- ③ Set SW401 to "2.IR" position
- ④ Provide AC power supply to this board, and turn on power supply switch (SW1).

Figure 6. IR Remote control



Note. "Lighting Communication Master Evaluation Board (EZ-0008)" can be used as IR remote controller.

- ⑤ Dimming control is possible by IR remote controller.
- ⑥ Turn off power supply switch "SW1".

 Danger	
	Do not touch to the high voltage area of the board. Touching the board by tools or body while power is being supplied cause product failure or electric shock.
	Do not touch with wet hands. Doing so cause product failure or electrical shock.
	Do not turn on power switch in insufficient state of cable connection such as AC power, fluorescent lamp connection cable, and communication cable. Doing so may cause product failure, generation of heat, fire or electric shock.
	Use this board with spacer and on the isolated bench. In case conductor contact to the board, it may cause product failure, generation of heat, fire or electric shock.
	Confirm the outlet is near this board and easily unplugged.
	If smoke or an abnormal smell or sound is emitted, or heating occurs, promptly switch off the board power and unplug from AC power supply. Using the board in such a state poses a risk of fire, burning, or electric shock.

3.3.3 DALI Protocol control

This board has DALI protocol interface circuit.

By using “DALI mode” of Serial Interface UART6/DALI peripheral, DALI slave communication via TxD6, RxD6 terminal can be realized easily.

- ① Connect Fluorescent Lamp
- ② Set SW501 to “RUN” side.
- ③ Set SW401 to “3.DALI” side.
- ④ Connect “Lighting Communication Master Evaluation Board (EZ-0008)”.
- ⑤ Provide AC power supply to this board, and turn on power supply switch (SW1).



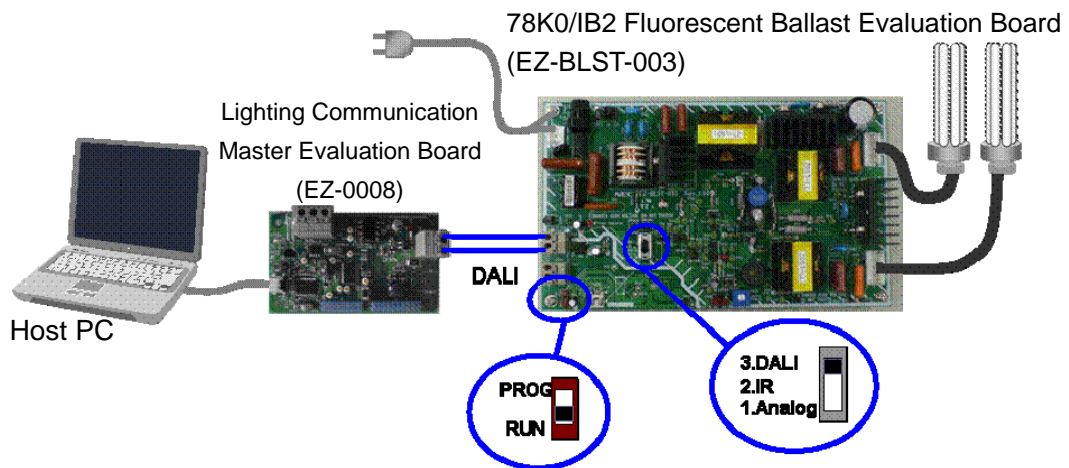



Figure 7. DALI Protocol control



Note. Please download “DALI master control GUI” from following URL.

URL : <http://www.necel.com/micro/en/solution/lighting/download.html>

- ⑥ Dimming control is possible by using DALI protocol.
- ⑦ Turn off power supply switch “SW1”.

 Danger	
	Do not touch to the high voltage area of the board. Touching the board by tools or body while power is being supplied cause product failure or electric shock.
	Do not touch with wet hands. Doing so cause product failure or electrical shock.
	Do not turn on power switch in insufficient state of cable connection such as AC power, fluorescent lamp connection cable, and communication cable. Doing so may cause product failure, generation of heat, fire or electric shock.
	Use this board with spacer and on the isolated bench. In case conductor contact to the board, it may cause product failure, generation of heat, fire or electric shock.
	Confirm the outlet is near this board and easily unplugged.
	If smoke or an abnormal smell or sound is emitted, or heating occurs, promptly switch off the board power and unplug from AC power supply. Using the board in such a state poses a risk of fire, burning, or electric shock.

3.4 On-chip debug mode

- ① Connect Fluorescent Lamp
- ② Connect this board to PC by using USB cable.
- ③ Set SW501 to “PROG” side.
- ④ Provide AC power supply to this board, and turn on power supply switch (SW1).

Figure 8. On-chip debug mode

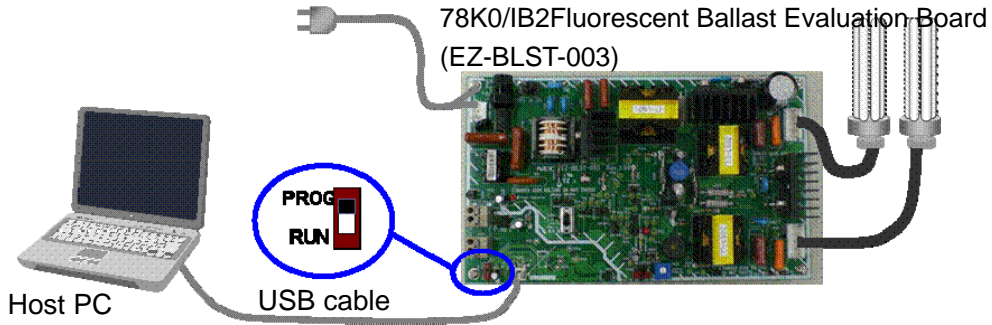

- ⑤ Setup debugger “ID78K0-QB”
On-chip debug is possible by using ID78K0-QB
- ⑥ Close ID78K0-QB
- ⑦ Turn off power supply switch “SW1”, and disconnect USB cable.





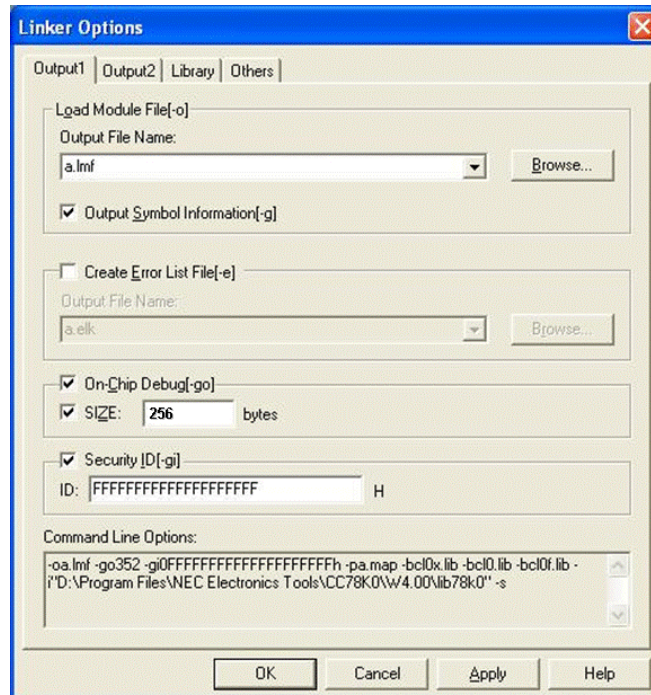

Note 1. When using on-chip debug function, it is necessary to be secured to embed the debug monitor program. Please set 256 byte as debug monitor program if the pseudo RRM function is not used. In case using NEC Electronics Compiler, this setting can be done by linker option as shown in figure 9.

Figure 9. Linker option setting



Note 2. When using on-chip debug function, please be care for the point and timing of step execution or break setting. If the program execution for PFC control or half-bridge control is stopped, it may cause product failure, generation of heat, fire.

Do not use “peripheral break” function especially for peripherals using for PFC control and half-bridge control.

 Danger	
	Do not touch to the high voltage area of the board. Touching the board by tools or body while power is being supplied cause product failure or electric shock.
	Do not touch with wet hands. Doing so cause product failure or electrical shock.
	Do not turn on power switch in insufficient state of cable connection such as AC power, fluorescent lamp connection cable, and communication cable. Doing so may cause product failure, generation of heat, fire or electric shock.
	Use this board with spacer and on the isolated bench. In case conductor contact to the board, it may cause product failure, generation of heat, fire or electric shock.
	Confirm the outlet is near this board and easily unplugged.
	If smoke or an abnormal smell or sound is emitted, or heating occurs, promptly switch off the board power and unplug from AC power supply. Using the board in such a state poses a risk of fire, burning, or electric shock.

Appendix B. Bill of Materials

Table B. Bill of Materials (1/3)

Part	Number	Product Name and Specifications	Function	Manufacturer	Manufacturer Product Name
IC	501	UPD78F0730MC-CAB-AX	Microcontroller	NEC Electronics Corporation	UPD78F0730MC-CAB-AX
IC	771	UPD78F0756MC-CAB-AX	Microcontroller	NEC Electronics Corporation	UPD78F0756MC-CAB-AX
IC	773	UPC78M05AHF-AZ	3-pin regulator	NEC Electronics Corporation	UPC78M05AHF-AZ
PC	301	PS2561AL-1	Photocoupler	NEC Electronics Corporation	PS2561AL-1
PC	302	PS2561AL-1	Photocoupler	NEC Electronics Corporation	PS2561AL-1
PC	501	PS9851-2	Photocoupler	NEC Electronics Corporation	PS9851-2
PC	502	PS9851-2	Photocoupler	NEC Electronics Corporation	PS9851-2
PC	503	PS9851-2	Photocoupler	NEC Electronics Corporation	PS9851-2
ZD	301	RD2.7S-T1-A	Zener diode	NEC Electronics Corporation	RD2.7S-T1-A
LF	1	SU10VD-20010	AC 250 V 2 A line filter	NEC TOKIN Corporation	SU10VD-20010
LF	2	SS24H-R20045-CH	AC 250 V 2 A line filter	NEC TOKIN Corporation	SS24H-R20045-CH
BZ	0	PS1440P02BT	Buzzer	TDK Corporation	PS1440P02BT
C	101	2KV 1000p	Ceramic capacitor	Murata Manufacturing Co., Ltd.	DEHR33D102KB3B
C	102	2KV 1000p	Ceramic capacitor	Murata Manufacturing Co., Ltd.	DEHR33D102KB3B
C	103	50V 470p	Monolithic ceramic capacitor	Murata Manufacturing Co., Ltd.	GRM2162C1H471JA01D
C	104	25V 0.47u	Monolithic ceramic capacitor	Murata Manufacturing Co., Ltd.	GRM219B31E474KA88D
C	105	50V 470p	Monolithic ceramic capacitor	Murata Manufacturing Co., Ltd.	GRM2162C1H471JA01D
C	111	400V 0.18u	Film capacitor	Panasonic Corporation	ECWF4184JB
C	112	4700p 2KV	Film capacitor	Nippon Chemi-Con Corporation	FHACD202V472JKLDZ0
C	211	400V 0.18u	Film capacitor	Panasonic Corporation	ECWF4184JB
C	212	4700p 2KV	Film capacitor	Nippon Chemi-Con Corporation	FHACD202V472JKLDZ0
C	220	50V 0.1u	Monolithic ceramic capacitor	Murata Manufacturing Co., Ltd.	GRM21BR11H104KA01L
C	301	25V 22u	Electrolytic capacitor	NICHICON CORPORATION	UPS1E220MDD
C	401	25V 10u	Electrolytic capacitor	NICHICON CORPORATION	UPS1E100MDD
C	501	25V 4.7u	Electrolytic capacitor	NICHICON CORPORATION	UPS1E4R7MDD
C	502	50V 0.1u	Monolithic ceramic capacitor	Murata Manufacturing Co., Ltd.	GRM21BR11H104KA01L
C	503	50V 0.1u	Monolithic ceramic capacitor	Murata Manufacturing Co., Ltd.	GRM21BR11H104KA01L
C	504	25V 0.47u	Monolithic ceramic capacitor	Murata Manufacturing Co., Ltd.	GRM219B31E474KA88D
C	505	50V 0.1u	Monolithic ceramic capacitor	Murata Manufacturing Co., Ltd.	GRM21BR11H104KA01L
C	506	50V 0.1u	Monolithic ceramic capacitor	Murata Manufacturing Co., Ltd.	GRM21BR11H104KA01L
C	508	50V 0.1u	Monolithic ceramic capacitor	Murata Manufacturing Co., Ltd.	GRM21BR11H104KA01L
C	511	50V 0.1u	Monolithic ceramic capacitor	Murata Manufacturing Co., Ltd.	GRM21BR11H104KA01L
C	512	50V 0.1u	Monolithic ceramic capacitor	Murata Manufacturing Co., Ltd.	GRM21BR11H104KA01L
C	513	10V 100u	Electrolytic capacitor	NICHICON CORPORATION	UPS1A101MDD
C	514	50V 39p	Monolithic ceramic capacitor	Murata Manufacturing Co., Ltd.	GRM2162C1H390JZ01D
C	515	50V 39p	Monolithic ceramic capacitor	Murata Manufacturing Co., Ltd.	GRM2162C1H390JZ01D
C	516	50V 0.1u	Monolithic ceramic capacitor	Murata Manufacturing Co., Ltd.	GRM21BR11H104KA01L
C	517	50V 0.1u	Monolithic ceramic capacitor	Murata Manufacturing Co., Ltd.	GRM21BR11H104KA01L
C	518	50V 0.1u	Monolithic ceramic capacitor	Murata Manufacturing Co., Ltd.	GRM21BR11H104KA01L
C	601	50V 0.1u	Monolithic ceramic capacitor	Murata Manufacturing Co., Ltd.	GRM21BR11H104KA01L
C	602	10V 1u	Monolithic ceramic capacitor	Murata Manufacturing Co., Ltd.	GRM216B11A105KA01
C	701	250VAC 0.33u	Film capacitor	NISSEI ELECTRIC CO., LTD.	MMDF 0250 K 334 0000 0150
C	702	250VAC 0.33u	Film capacitor	NISSEI ELECTRIC CO., LTD.	MMDF 0250 K 334 0000 0150
C	703	50V 0.1u	Monolithic ceramic capacitor	Murata Manufacturing Co., Ltd.	GRM21BR11H104KA01L
C	704	2KV 1000p	Ceramic capacitor	Murata Manufacturing Co., Ltd.	DEHR33D102KB3B
C	705	2KV 1000p	Ceramic capacitor	Murata Manufacturing Co., Ltd.	DEHR33D102KB3B
C	706	2KV 1000p	Ceramic capacitor	Murata Manufacturing Co., Ltd.	DEHR33D102KB3B
C	711	450V 1u	Film capacitor	Rubycon Corporation	450MMK105K
C	712	450V 1u	Film capacitor	Rubycon Corporation	450MMK105K
C	713	1KV 470p	Ceramic capacitor	Murata Manufacturing Co., Ltd.	DEHR33A332KA3B
C	714	450V 47u	Electrolytic capacitor	Rubycon Corporation	450BXA47MCC(18x31.5)
C	717	25V 22u	Electrolytic capacitor	NICHICON CORPORATION	UPS1E220MDD
C	719	50V 100u	Electrolytic capacitor	NICHICON CORPORATION	UPS1H101MPD
C	723	10V 1u	Monolithic ceramic capacitor	Murata Manufacturing Co., Ltd.	GRM216B11A105KA01
C	775	25V 47u	Electrolytic capacitor	NICHICON CORPORATION	UPS1E470MPDD
CN	101	B5P-VH (LF)(SN)	Connector	J.S.T. Mfg. Co., Ltd.	B5P-VH (LF)(SN)
CN	201	B5P-VH (LF)(SN)	Connector	J.S.T. Mfg. Co., Ltd.	B5P-VH (LF)(SN)
CN	301	ML-800-S1V-2P	Connector	SATO PARTS CO., LTD.	ML-800-S1V-2P
CN	302	ML-800-S1V-2P	Connector	SATO PARTS CO., LTD.	ML-800-S1V-2P
CN	501	UX60A-MB-5ST	Connector	HIROSE ELECTRIC CO., LTD.	UX60A-MB-5ST
CN	701	B2P3-VH (LF)(SN)	Connector	J.S.T. Mfg. Co., Ltd.	B2P3-VH (LF)(SN)
D	101	EP04RA60	FRD	Nihon Inter Electronics Corporation	EP04RA60
D	102	EP04RA60	FRD	Nihon Inter Electronics Corporation	EP04RA60
D	103	1SS133	Diode	ROHM Co., Ltd.	1SS133
D	104	1SS133	Diode	ROHM Co., Ltd.	1SS133
D	105	1SS133	Diode	ROHM Co., Ltd.	1SS133
D	106	1SS133	Diode	ROHM Co., Ltd.	1SS133
D	301	1SS133	Diode	ROHM Co., Ltd.	1SS133
D	501	1SS133	Diode	ROHM Co., Ltd.	1SS133
D	702	D1N60 5060	Diode	Shindengen Electric Manufacturing Co., Ltd.	D1N60 5060
D	703	1SS133	Diode	ROHM Co., Ltd.	1SS133
D	704	1SS133	Diode	ROHM Co., Ltd.	1SS133
D	707	D5L60 7000	FRD	Shindengen Electric Manufacturing Co., Ltd.	D5L60 7000
D	708	30PUB60	FRD	Nihon Inter Electronics Corporation	30PUB60
D	709	30PUB60	FRD	Nihon Inter Electronics Corporation	30PUB60
D	710	1SS133	Diode	ROHM Co., Ltd.	1SS133
D	711	1SS133	Diode	ROHM Co., Ltd.	1SS133
DB	1	D4SB60 L 7000	D bridge (AC)	Shindengen Electric Manufacturing Co., Ltd.	D4SB60 L 7000
DB	2	S1NBC60-7101	D bridge	Shindengen Electric Manufacturing Co., Ltd.	S1NBC60-7101
F	1	3.0A	Glass tube fuse	YOUNG Corporation	2MF-3
F	1	F-105	Fuse holder	SATO PARTS CO., LTD.	F-105
IC	772	MIP0221SU	IPD	Panasonic Corporation	MIP0221SU
IC	401	GP1UX511QS 38KHz	Remote light receiving unit	Sharp Corporation	GP1UX511QS 38KHz

Table B. Bill of Materials (2/3)

Part	Number	Product Name and Specifications	Function	Manufacturer	Manufacturer Product Name
JMP	401A	DSP02-002-431G	Short plug	KEL Corporation	DSP02-002-431G
JMP	401B	DSP02-002-431G	Short plug	KEL Corporation	DSP02-002-431G
JMP	401C	DSP02-002-431G	Short plug	KEL Corporation	DSP02-002-431G
JMP	401D	DSP02-002-431G	Short plug	KEL Corporation	DSP02-002-431G
JMP	401E	DSP02-002-431G	Short plug	KEL Corporation	DSP02-002-431G
JMP	401F	DSP02-002-431G	Short plug	KEL Corporation	DSP02-002-431G
JMP	401G	DSP02-002-431G	Short plug	KEL Corporation	DSP02-002-431G
JMP	401H	DSP02-002-431G	Short plug	KEL Corporation	DSP02-002-431G
JMP	401I	DSP02-002-431G	Short plug	KEL Corporation	DSP02-002-431G
JMP	401J	DSP02-002-431G	Short plug	KEL Corporation	DSP02-002-431G
JMP	501A	DSP02-002-431G	Short plug	KEL Corporation	DSP02-002-431G
JMP	501B	DSP02-002-431G	Short plug	KEL Corporation	DSP02-002-431G
JMP	501C	DSP02-002-431G	Short plug	KEL Corporation	DSP02-002-431G
JMP	501D	DSP02-002-431G	Short plug	KEL Corporation	DSP02-002-431G
L	101	77-L002	Inductor 1mH	Tashiro Densetsu Corporation	77-L002
L	201	77-L002	Inductor 1mH	Tashiro Densetsu Corporation	77-L002
L	501	BLM41PG750SN1L	Chip Inductor	Murata Manufacturing Co., Ltd.	BLM41PG750SN1L
L	701	2200uH	Inductor	TDK Corporation	TSL 1112-2222JR33
LED	1	SLR332VR3F	LED	ROHM Co., Ltd.	SLR332VR3F
LED	2	SLR332VR3F	LED	ROHM Co., Ltd.	SLR332VR3F
MOV	0	ERV09D511	Absorber	Panasonic Corporation	ERV09D511
NTC	0	NTPAJ100LDKB0	NTC thermistor	Murata Manufacturing Co., Ltd.	NTPAJ100LDKB0
Q	101	RJK5012DPP-00-T2	Power MOSFET	Renesas Technology Corp.	RJK5012DPP-00-T2
Q	102	RJK5012DPP-00-T2	Power MOSFET	Renesas Technology Corp.	RJK5012DPP-00-T2
Q	103	2SC2412KT146R	NPN transistor	ROHM Co., Ltd.	2SC2412KT146R
Q	104	2SA1037AKT146R	PNP transistor	ROHM Co., Ltd.	2SA1037AKT146R
Q	105	2SC2412KT146R	NPN transistor	ROHM Co., Ltd.	2SC2412KT146R
Q	106	2SA1037AKT146R	PNP transistor	ROHM Co., Ltd.	2SA1037AKT146R
Q	107	IRFR430APbF	Power MOSFET	Vishay Intertechnology, Inc.	IRFR430APbF
Q	108	2SC2412KT146R	NPN transistor	ROHM Co., Ltd.	2SC2412KT146R
Q	109	2SC2412KT146R	NPN transistor	ROHM Co., Ltd.	2SC2412KT146R
Q	110	2SC2412KT146R	NPN transistor	ROHM Co., Ltd.	2SC2412KT146R
Q	301	2SC2412KT146R	NPN transistor	ROHM Co., Ltd.	2SC2412KT146R
Q	401	2SC2412KT146R	NPN transistor	ROHM Co., Ltd.	2SC2412KT146R
Q	402	2SA1037AKT146R	PNP transistor	ROHM Co., Ltd.	2SA1037AKT146R
Q	703	RJK5012DPP-00-T2	Power MOSFET	Renesas Technology Corp.	RJK5012DPP-00-T2
Q	704	2SC2412KT146R	NPN transistor	ROHM Co., Ltd.	2SC2412KT146R
Q	705	2SC2412KT146R	NPN transistor	ROHM Co., Ltd.	2SC2412KT146R
Q	706	2SC2412KT146R	NPN transistor	ROHM Co., Ltd.	2SC2412KT146R
Q	707	2SA1037AKT146R	PNP transistor	ROHM Co., Ltd.	2SA1037AKT146R
Q	708	2SC2412KT146R	NPN transistor	ROHM Co., Ltd.	2SC2412KT146R
Q	709	2SC2412KT146R	NPN transistor	ROHM Co., Ltd.	2SC2412KT146R
R	101	10 3216	Chip resistor	KOA Corporation	RK73B2ATTD100G
R	102	5.1K 2W	Coat insulation metal film resistor	KOA Corporation	MOS2C(T52A)512J
R	103	2.4K 3216	Chip resistor	KOA Corporation	RK73B2ATTD242G
R	104	2.4K 3216	Chip resistor	KOA Corporation	RK73B2ATTD242G
R	105	200 2125	Chip resistor	KOA Corporation	RK73B2ATTD201G
R	106	10K 2W	Coat insulation metal film resistor	KOA Corporation	MOS2C(T52A)103J
R	107	20 2125	Chip resistor	KOA Corporation	RK73B2ATTD200G
R	108	6.8K 2125	Chip resistor	KOA Corporation	RK73B2ATTD682G
R	109	1K 2125	Chip resistor	KOA Corporation	RK73B2ATTD102G
R	110	24K 2125	Chip resistor	KOA Corporation	RK73B2ATTD243G
R	111	200 2125	Chip resistor	KOA Corporation	RK73B2ATTD201G
R	112	6.8K 2125	Chip resistor	KOA Corporation	RK73B2ATTD682G
R	113	430 2125	Chip resistor	KOA Corporation	RK73B2ATTD431G
R	114	20 2125	Chip resistor	KOA Corporation	RK73B2ATTD200G
R	115	6.8K 2125	Chip resistor	KOA Corporation	RK73B2ATTD682G
R	117	51 2125	Chip resistor	KOA Corporation	RK73B2ATTD510G
R	119	10K 2125	Chip resistor	KOA Corporation	RK73B2ATTD103G
R	120	10K 2125	Chip resistor	KOA Corporation	RK73B2ATTD103G
R	121	4.7K 2125	Chip resistor	KOA Corporation	RK73B2ATTD472G
R	123	4.7K 2125	Chip resistor	KOA Corporation	RK73B2ATTD472G
R	124	10K 2125	Chip resistor	KOA Corporation	RK73B2ATTD103G
R	125	10K 2125	Chip resistor	KOA Corporation	RK73B2ATTD103G
R	126	10K 2125	Chip resistor	KOA Corporation	RK73B2ATTD103G
R	301	1.2K 2125	Chip resistor	KOA Corporation	RK73B2ATTD122G
R	302	330 2125	Chip resistor	KOA Corporation	RK73B2ATTD331G
R	303	3.3k 2125	Chip resistor	KOA Corporation	RK73B2ATTD332G
R	304	4.7 2125	Chip resistor	KOA Corporation	RK73B2ATTD4R7G
R	305	11k 2125	Chip resistor	KOA Corporation	RK73B2ATTD113G
R	306	0 2125	Chip resistor	KOA Corporation	RK73Z2ATTD
R	307	10K 2125	Chip resistor	KOA Corporation	RK73B2ATTD103G
R	308	0 2125	Chip resistor	KOA Corporation	RK73Z2ATTD
R	402	33K 2125	Chip resistor	KOA Corporation	RK73B2ATTD333G
R	403	33K 2125	Chip resistor	KOA Corporation	RK73B2ATTD333G
R	404	22K 2125	Chip resistor	KOA Corporation	RK73B2ATTD223G
R	405	10K 2125	Chip resistor	KOA Corporation	RK73B2ATTD103G
R	406	10K 2125	Chip resistor	KOA Corporation	RK73B2ATTD103G
R	407	10K 2125	Chip resistor	KOA Corporation	RK73B2ATTD103G
R	408	3.3K 2125	Chip resistor	KOA Corporation	RK73B2ATTD332B
R	409	1K 2125	Chip resistor	KOA Corporation	RK73B2ATTD102G
R	410	1K 2125	Chip resistor	KOA Corporation	RK73B2ATTD102G
R	411	100k 2125	Chip resistor	KOA Corporation	RK73B2ATTD104G
R	413	100k 2125	Chip resistor	KOA Corporation	RK73B2ATTD104G
R	414	2.2k 2125	Chip resistor	KOA Corporation	RK73B2ATTD222G
R	415	100k 2125	Chip resistor	KOA Corporation	RK73B2ATTD104G
R	416	100k 2125	Chip resistor	KOA Corporation	RK73B2ATTD104G
R	421	100k 2125	Chip resistor	KOA Corporation	RK73B2ATTD104G
R	422	100k 2125	Chip resistor	KOA Corporation	RK73B2ATTD104G
R	423	330k 2125	Chip resistor	KOA Corporation	RK73B2ATTD334G
R	424	330k 2125	Chip resistor	KOA Corporation	RK73B2ATTD334G
R	501	10k 2125	Chip resistor	KOA Corporation	RK73B2ATTD103G
R	502	1.5k 2125	Chip resistor	KOA Corporation	RK73B2ATTD152G

Table B. Bill of Materials (3/3)

Part	Number	Product Name and Specifications	Function	Manufacturer	Manufacturer Product Name
R	503	27 2125	Chip resistor	KOA Corporation	RK73B2ATTD270G
R	504	27 2125	Chip resistor	KOA Corporation	RK73B2ATTD270G
R	505	10k 2125	Chip resistor	KOA Corporation	RK73B2ATTD103G
R	506	1k 2125	Chip resistor	KOA Corporation	RK73B2ATTD102G
R	507	100k 2125	Chip resistor	KOA Corporation	RK73B2ATTD104G
R	508	100k 2125	Chip resistor	KOA Corporation	RK73B2ATTD104G
R	509	100k 2125	Chip resistor	KOA Corporation	RK73B2ATTD104G
R	510	330 2125	Chip resistor	KOA Corporation	RK73B2ATTD331G
R	511	10k 2125	Chip resistor	KOA Corporation	RK73B2ATTD103G
R	512	330 2125	Chip resistor	KOA Corporation	RK73B2ATTD331G
R	513	100k 2125	Chip resistor	KOA Corporation	RK73B2ATTD104G
R	514	100k 2125	Chip resistor	KOA Corporation	RK73B2ATTD104G
R	515	330 2125	Chip resistor	KOA Corporation	RK73B2ATTD331G
R	516	330 2125	Chip resistor	KOA Corporation	RK73B2ATTD331G
R	517	330 2125	Chip resistor	KOA Corporation	RK73B2ATTD331G
R	518	10k 2125	Chip resistor	KOA Corporation	RK73B2ATTD103G
R	519	1K 2125	Chip resistor	KOA Corporation	RK73B2ATTD102G
R	520	330 2125	Chip resistor	KOA Corporation	RK73B2ATTD331G
R	521	100 2125	Chip resistor	KOA Corporation	RK73B2ATTD101G
R	522	1k 2125	Chip resistor	KOA Corporation	RK73B2ATTD102G
R	523	10K 2125	Chip resistor	KOA Corporation	RK73B2ATTD103G
R	701	10K 2125	Chip resistor	KOA Corporation	RK73B2ATTD103G
R	702	10K 2125	Chip resistor	KOA Corporation	RK73B2ATTD103G
R	703	10K 2125	Chip resistor	KOA Corporation	RK73B2ATTD103G
R	704	0.1 3W	Coat insulation metal film resistor	KOA Corporation	MOS3C(T52A)R10J
R	705	10 2W	Coat insulation metal film resistor	KOA Corporation	MOS2C(T52A)100G
R	706	330K 3216	Chip resistor	KOA Corporation	RK73B2BTTD334G
R	707	330K 3216	Chip resistor	KOA Corporation	RK73B2BTTD334G
R	708	6.8K 2125	Chip resistor	KOA Corporation	RK73B2ATTD682G
R	709	47k 3216	Chip resistor	KOA Corporation	RK73B2BTTD473G
R	710	10K 2125	Chip resistor	KOA Corporation	RK73B2ATTD103G
R	711	10K 2125	Chip resistor	KOA Corporation	RK73B2ATTD103G
R	712	10K 2125	Chip resistor	KOA Corporation	RK73B2ATTD103G
R	713	10K 2125	Chip resistor	KOA Corporation	RK73B2ATTD103G
R	714	4.7K 2125	Chip resistor	KOA Corporation	RK73B2ATTD472G
R	715	10K 2125	Chip resistor	KOA Corporation	RK73B2ATTD103G
R	716	4.7K 2125	Chip resistor	KOA Corporation	RK73B2ATTD472G
R	717	220 2125	Chip resistor	KOA Corporation	RK73B2ATTD221G
R	718	220 2125	Chip resistor	KOA Corporation	RK73B2ATTD221G
R	719	220 2125	Chip resistor	KOA Corporation	RK73B2ATTD221G
R	720	10 2125	Chip resistor	KOA Corporation	RK73B2ATTD100G
R	721	6.8k 2125	Chip resistor	KOA Corporation	RK73B2ATTD682G
R	722	330k 3216	Chip resistor	KOA Corporation	RK73B2BTTD334G
R	723	330k 3216	Chip resistor	KOA Corporation	RK73B2BTTD334G
R	724	6.8k 2125	Chip resistor	KOA Corporation	RK73B2ATTD682G
R	725	47k 3216	Chip resistor	KOA Corporation	RK73B2BTTD473G
R	762	2.2k 2125	Chip resistor	KOA Corporation	RK73B2ATTD222G
SW	1	M2T-12AAP1	Power switch	NIHON KAIHEIKI IND. CO., Ltd.	M2T-12AAP1
SW	401	SSSF014800	Selector switch	ALPS ELECTRIC CO., LTD.	SSSF014800
SW	402	SS-12SDP2	Slide switch	NIHON KAIHEIKI IND. CO., Ltd.	SS-12SDP2
SW	501	SS-12SDP2	Slide switch	NIHON KAIHEIKI IND. CO., Ltd.	SS-12SDP2
SW	502	SKHRAAA010	Tact switch	ALPS ELECTRIC CO., LTD.	SKHRAAA010
T	1	77-L001	Inductor	Tashiro Densetsu Corporation	77-L001
TP	1	LC-2-G -green	Test pin	Mac-Eight Co., Ltd.	LC-2-G -green
TP	2	LC-2-G -green	Test pin	Mac-Eight Co., Ltd.	LC-2-G -green
TP	3	LC-2-G -green	Test pin	Mac-Eight Co., Ltd.	LC-2-G -green
TP	4	LC-2-G -green	Test pin	Mac-Eight Co., Ltd.	LC-2-G -green
TP	5	LC-2-G -green	Test pin	Mac-Eight Co., Ltd.	LC-2-G -green
TP	6	LC-2-G -green	Test pin	Mac-Eight Co., Ltd.	LC-2-G -green
TP	7	LC-2-G -green	Test pin	Mac-Eight Co., Ltd.	LC-2-G -green
TP	11	LC-2-G -black	Test pin	Mac-Eight Co., Ltd.	LC-2-G -black
TP	12	LC-2-G -green	Test pin	Mac-Eight Co., Ltd.	LC-2-G -green
TP	13	LC-2-G -green	Test pin	Mac-Eight Co., Ltd.	LC-2-G -green
TP	14	LC-2-G -green	Test pin	Mac-Eight Co., Ltd.	LC-2-G -green
TP	15	LC-2-G -green	Test pin	Mac-Eight Co., Ltd.	LC-2-G -green
TP	16	LC-2-G -green	Test pin	Mac-Eight Co., Ltd.	LC-2-G -green
TP	17	LC-2-G -green	Test pin	Mac-Eight Co., Ltd.	LC-2-G -green
TP	19	LC-2-G -green	Test pin	Mac-Eight Co., Ltd.	LC-2-G -green
TP	20	LC-2-G -green	Test pin	Mac-Eight Co., Ltd.	LC-2-G -green
TP	21	LC-2-G -green	Test pin	Mac-Eight Co., Ltd.	LC-2-G -green
TP	22	LC-2-G -green	Test pin	Mac-Eight Co., Ltd.	LC-2-G -green
TP	23	LC-2-G -green	Test pin	Mac-Eight Co., Ltd.	LC-2-G -green
TP	24	LC-2-G -green	Test pin	Mac-Eight Co., Ltd.	LC-2-G -green
TP	25	LC-2-G -green	Test pin	Mac-Eight Co., Ltd.	LC-2-G -green
TP	26	LC-2-G -green	Test pin	Mac-Eight Co., Ltd.	LC-2-G -green
TP	29	LC-2-G -green	Test pin	Mac-Eight Co., Ltd.	LC-2-G -green
TP	30	LC-2-G -green	Test pin	Mac-Eight Co., Ltd.	LC-2-G -green
TP	31	LC-2-G -green	Test pin	Mac-Eight Co., Ltd.	LC-2-G -green
TP	32	LC-2-G -green	Test pin	Mac-Eight Co., Ltd.	LC-2-G -green
TP	33	LC-2-G -green	Test pin	Mac-Eight Co., Ltd.	LC-2-G -green
TP	34	LC-2-G -green	Test pin	Mac-Eight Co., Ltd.	LC-2-G -green
TP	35	LC-2-G -green	Test pin	Mac-Eight Co., Ltd.	LC-2-G -green
TP	36	LC-2-G -green	Test pin	Mac-Eight Co., Ltd.	LC-2-G -green
TP	37	LC-2-G -green	Test pin	Mac-Eight Co., Ltd.	LC-2-G -green
TP	38	LC-2-G -green	Test pin	Mac-Eight Co., Ltd.	LC-2-G -green
U	501	TC74VHC125F	IC	Toshiba Semiconductor Company	TC74VHC125F
U	502	TC74VHC14F	IC	Toshiba Semiconductor Company	TC74VHC14F
U	503	TC74VHC14F	IC	Toshiba Semiconductor Company	TC74VHC14F
U	504	TC74VHC125F	IC	Toshiba Semiconductor Company	TC74VHC125F
VR	401	100K	Volume dial	Bourns Inc.	3386F-1-104TLF
Y	701	CMR309T-16.000MABJ-UT	Oscillator	CITIZEN ELECTRONICS CO., LTD	CMR309T-16.000MABJ-UT
ZD	201	4.7V	Zener diode	ROHM Co., Ltd.	MTZJ T-77 4.7B
ZD	701	7.5V	Zener diode	ROHM Co., Ltd.	MTZJ T-77 7.5B

Appendix C. Revision History

Revision	Modified Points	Page
Rev.1.0		

***For further information,
please contact:***

NEC Electronics Corporation

1753, Shimonumabe, Nakahara-ku,

Kawasaki, Kanagawa 211-8668,

Japan

Tel: +81-44-435-111

<http://www.necel.com/>

[Technical Support]

Multipurpose Microcomputer System Division, NEC Electronics Tel: +81-44-435-9452

Data Published March 2009