

PNP Silicon

Features

We declare that the material of product compliance with RoHS requirements.

Pb-Free package is available

RoHS product for packing code suffix "G"

Halogen free product for packing code suffix "H"

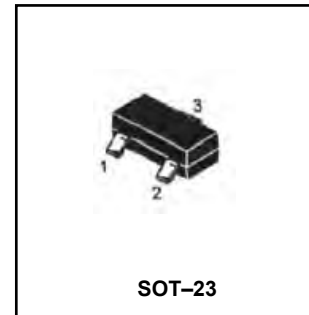
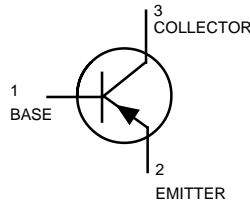

MAXIMUM RATINGS

Rating	Symbol	Value	Unit
Collector-Emitter Voltage	V_{CEO}	- 45	Vdc
Emitter-Base Voltage	V_{EBO}	- 5.0	Vdc
Collector Current — Continuous	I_C	- 100	mAdc

THERMAL CHARACTERISTICS

Characteristic	Symbol	Max	Unit
Total Device Dissipation FR-5 Board, (1) $T_A = 25^\circ\text{C}$	P_D	225	mW
Derate above 25°C		1.8	mW/ $^\circ\text{C}$
Thermal Resistance, Junction to Ambient	$R_{\theta JA}$	556	$^\circ\text{C}/\text{W}$
Total Device Dissipation Alumina Substrate, (2) $T_A = 25^\circ\text{C}$	P_D	300	mW
Derate above 25°C		2.4	mW/ $^\circ\text{C}$
Thermal Resistance, Junction to Ambient	$R_{\theta JA}$	417	$^\circ\text{C}/\text{W}$
Junction and Storage Temperature	T_J, T_{stg}	-55 to +150	$^\circ\text{C}$

DEVICE MARKING

BCW69LT1 = H1; BCW70LT1 = H2

ELECTRICAL CHARACTERISTICS ($T_A = 25^\circ\text{C}$ unless otherwise noted.)

Characteristic	Symbol	Min	Max	Unit
----------------	--------	-----	-----	------

OFF CHARACTERISTICS

Collector-Emitter Breakdown Voltage ($I_C = -2.0 \text{ mAdc}, I_B = 0$)	$V_{(BR)CEO}$	- 45	—	Vdc
Collector-Emitter Breakdown Voltage ($I_C = -100 \mu\text{Adc}, V_{EB} = 0$)	$V_{(BR)CES}$	- 50	—	Vdc
Emitter-Base Breakdown Voltage ($I_E = -10 \mu\text{Adc}, I_C = 0$)	$V_{(BR)EBO}$	- 5.0	—	Vdc
Collector Cutoff Current	I_{CEO}			
($V_{CE} = -20 \text{ Vdc}, I_E = 0$)		—	- 100	nAdc
($V_{CE} = -20 \text{ Vdc}, I_E = 0, T_A = 100^\circ\text{C}$)		—	- 10	μAdc

1. FR-5 = $1.0 \times 0.75 \times 0.062 \text{ in.}$

2. Alumina = $0.4 \times 0.3 \times 0.024 \text{ in.}$ 99.5% alumina.

ELECTRICAL CHARACTERISTICS ($T_A = 25^\circ\text{C}$ unless otherwise noted) (Continued)

Characteristic	Symbol	Min	Max	Unit
ON CHARACTERISTICS				
DC Current Gain ($I_C = -2.0 \text{ mA dc}$, $V_{CE} = -5.0 \text{ V dc}$)	h_{FE}	120	260	—
		215	500	
Collector–Emitter Saturation Voltage ($I_C = -10 \text{ mA dc}$, $I_B = -0.5 \text{ mA dc}$)	$V_{CE(sat)}$	—	-0.3	Vdc
Base–Emitter On Voltage ($I_C = -2.0 \text{ mA dc}$, $V_{CE} = -5.0 \text{ V dc}$)	$V_{BE(on)}$	-0.6	-0.75	Vdc
SMALL–SIGNAL CHARACTERISTICS				
Output Capacitance ($I_E = 0 \text{ V}$, $V_{CB} = -10 \text{ V dc}$, $f = 1.0 \text{ MHz}$)	C_{obo}	—	7.0	pF
Noise Figure ($V_{CE} = -5.0 \text{ V dc}$, $I_C = -0.2 \text{ mA dc}$, $R_S = 2.0 \text{ k}\Omega$, $f = 1.0 \text{ kHz}$, $BW = 200 \text{ Hz}$)	N_F	—	10	dB

Ordering Information

Device	Marking	Shipping
BCW69LT1	H1	3000/Tape&Reel
BCW70LT1	H2	3000/Tape&Reel

TYPICAL NOISE CHARACTERISTICS

($V_{CE} = -5.0 \text{ Vdc}$, $T_A = 25^\circ\text{C}$)

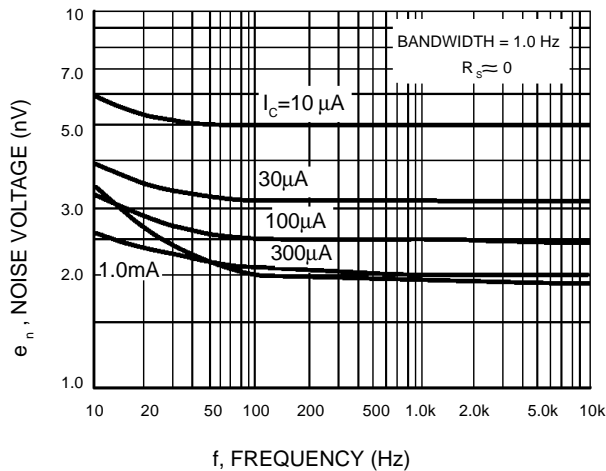

Figure 1. Noise Voltage

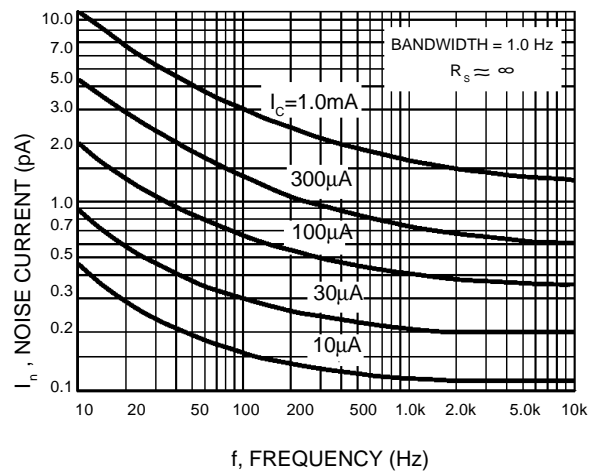

Figure 2. Noise Current

NOISE FIGURE CONTOURS

($V_{CE} = -5.0 \text{ Vdc}$, $T_A = 25^\circ\text{C}$)

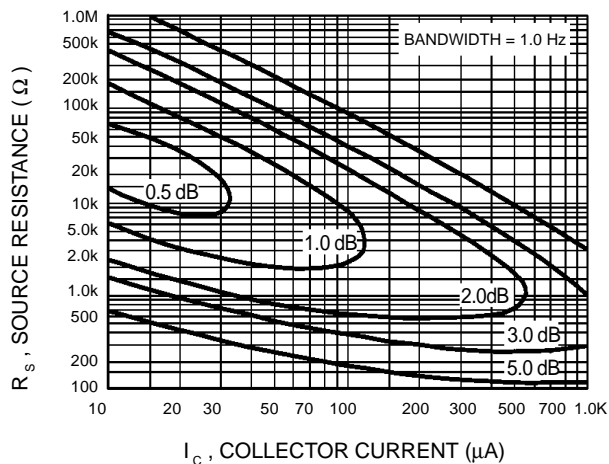

Figure 3. Narrow Band, 100 Hz

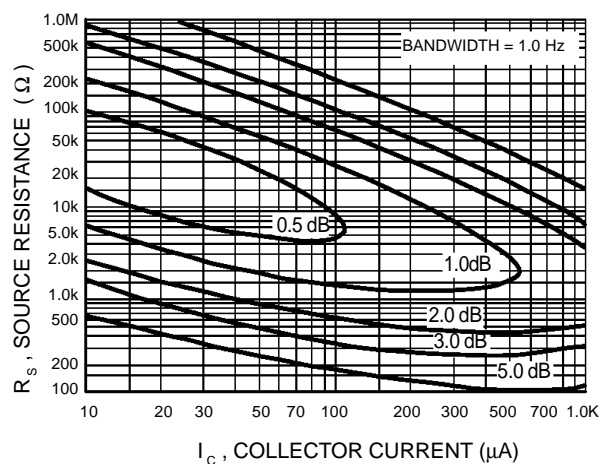

Figure 4. Narrow Band, 1.0 kHz

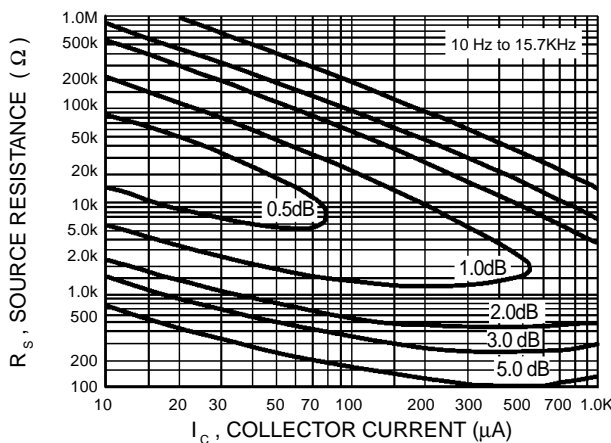

Figure 5. Wideband

Noise Figure is Defined as:

$$NF = 20 \log_{10} \left(\frac{e_n^2 + 4KTR_s + I_n^2 R_s^2}{4KTR_s} \right)^{1/2}$$

e_n = Noise Voltage of the Transistor referred to the input. (Figure 3)

I_n = Noise Current of the Transistor referred to the input. (Figure 4)

K = Boltzman's Constant ($1.38 \times 10^{-23} \text{ J/}^\circ\text{K}$)

T = Temperature of the Source Resistance ($^\circ\text{K}$)

R_s = Source Resistance (Ω)

TYPICAL STATIC CHARACTERISTICS

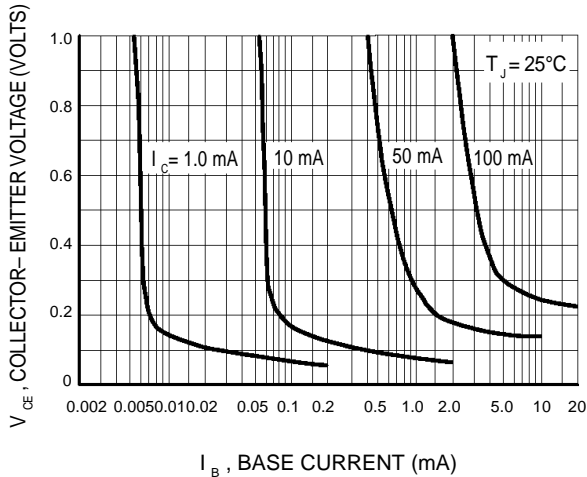

Figure 6. Collector Saturation Region

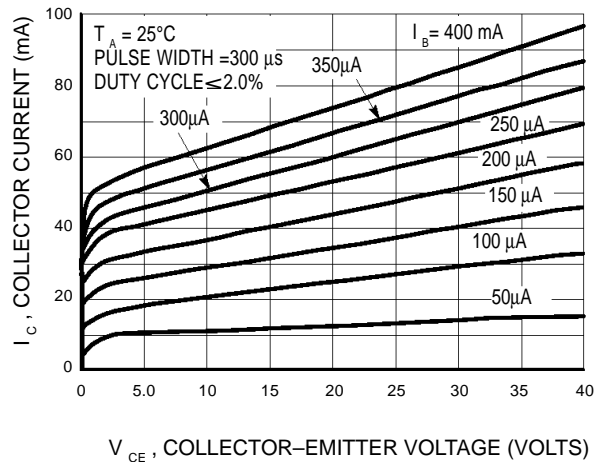

Figure 7. Collector Characteristics

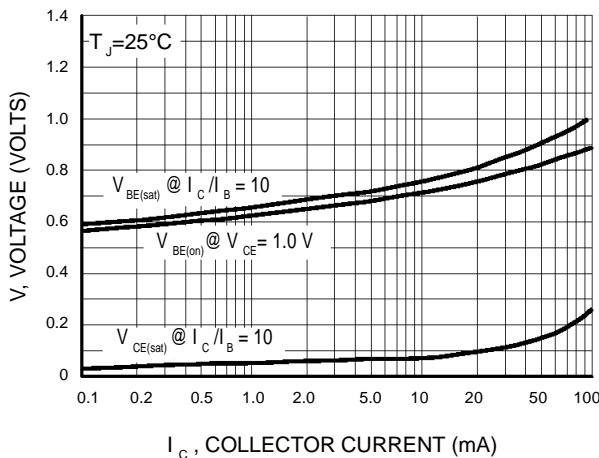

Figure 10. "On" Voltages

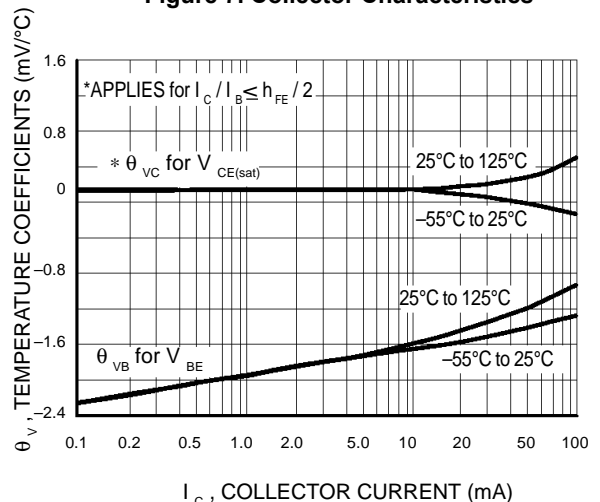
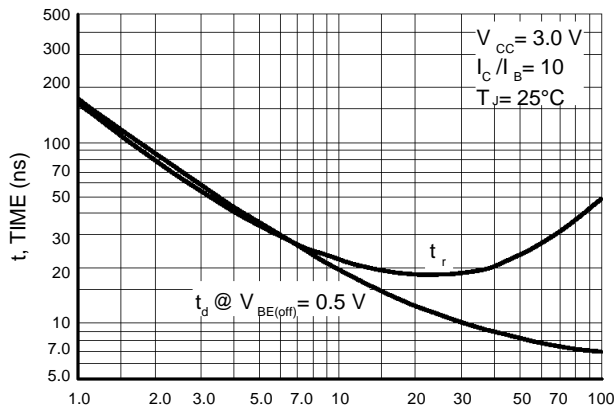

Figure 11. Temperature Coefficients

TYPICAL DYNAMIC CHARACTERISTICS



I_C , COLLECTOR CURRENT (mA)

Figure 10. Turn-On Time

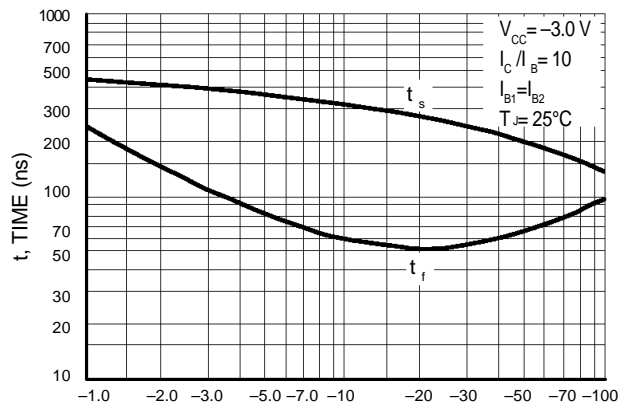

I_C , COLLECTOR CURRENT (mA)

Figure 11. Turn-Off Time

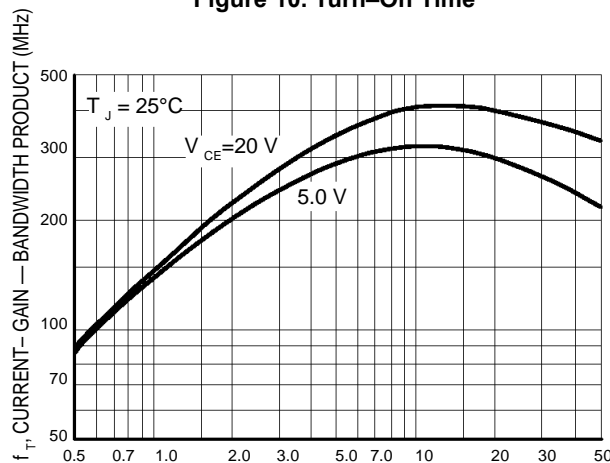

I_C , COLLECTOR CURRENT (mA)

Figure 12. Current-Gain — Bandwidth Product

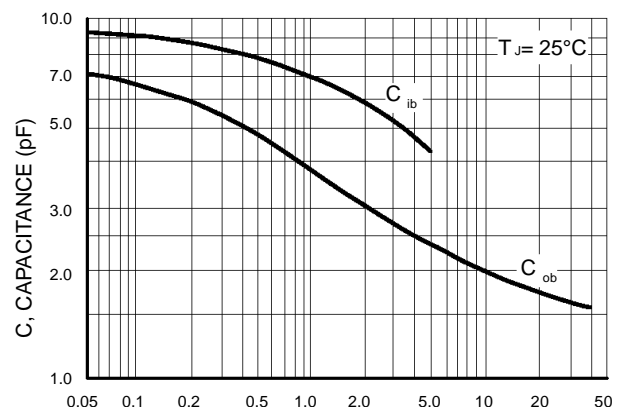

V_R , REVERSE VOLTAGE (VOLTS)

Figure 13. Capacitance

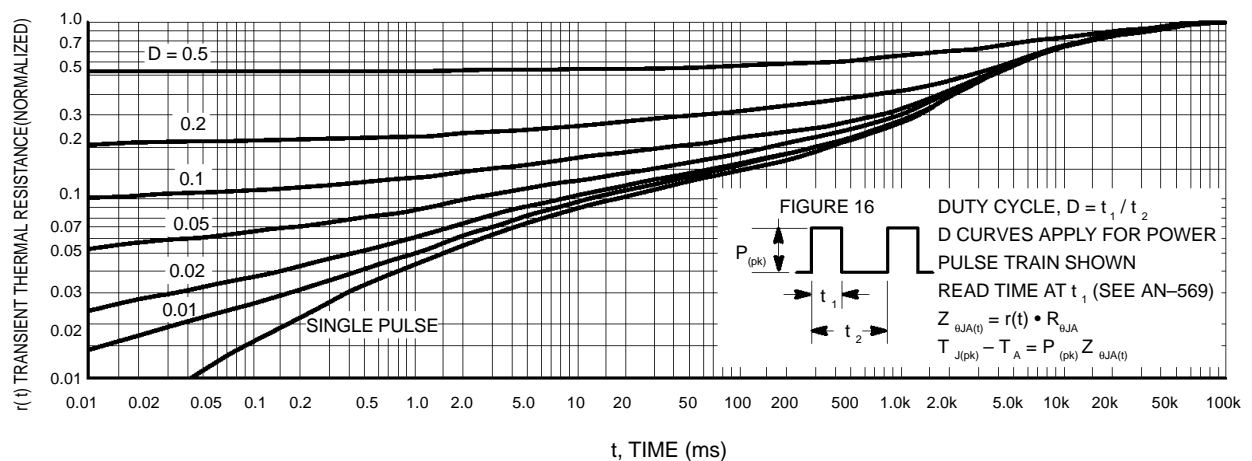

t, TIME (ms)

Figure 14. Thermal Response

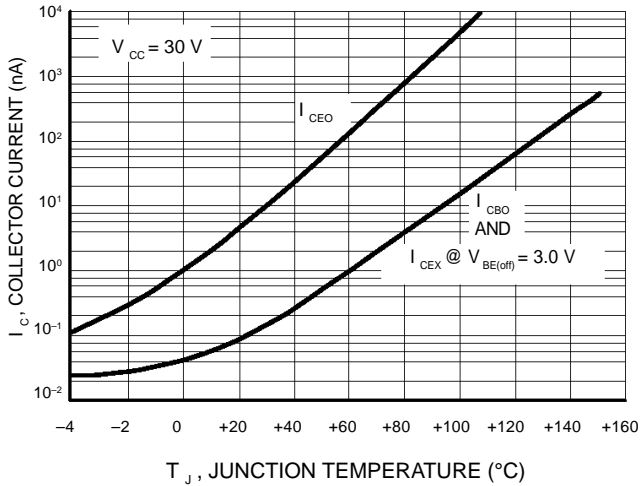

Figure 15. Typical Collector Leakage Current

DESIGN NOTE: USE OF THERMAL RESPONSE DATA

A train of periodical power pulses can be represented by the model as shown in Figure 16. Using the model and the device thermal response the normalized effective transient thermal resistance of Figure 14 was calculated for various duty cycles.

To find $Z_{\theta JA(t)}$, multiply the value obtained from Figure 14 by the steady state value $R_{\theta JA}$.

Example:

Dissipating 2.0 watts peak under the following conditions:

$$t_1 = 1.0 \text{ ms}, t_2 = 5.0 \text{ ms. (D = 0.2)}$$

Using Figure 14 at a pulse width of 1.0 ms and $D = 0.2$, the reading of $r(t)$ is 0.22.

The peak rise in junction temperature is therefore

$$\Delta T = r(t) \times P_{(pk)} \times R_{\theta JA} = 0.22 \times 2.0 \times 200 = 88^\circ\text{C}.$$

For more information, see AN-569.

SOT-23

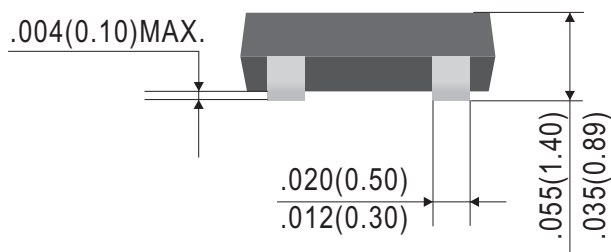
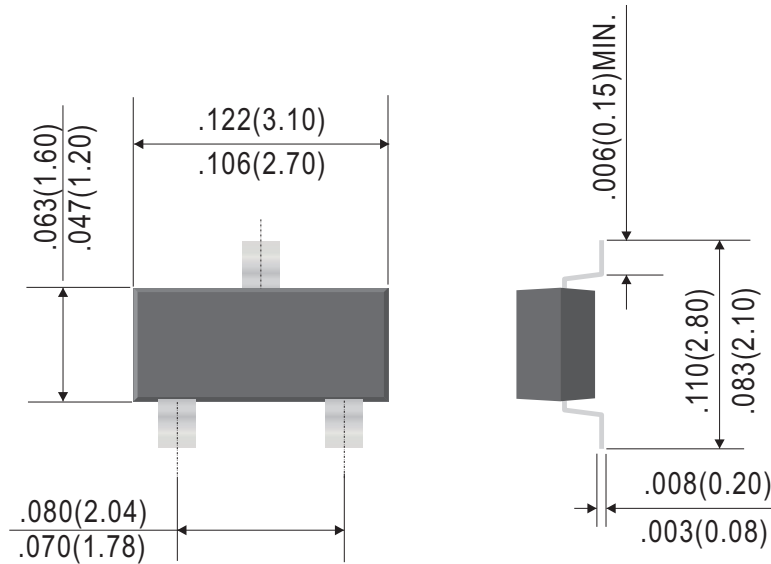

Dimensions in inches and (millimeters)

