

## FEATURES/BENEFITS

- Pin and function compatible to the Am2952/3 29FCT52/53 and 29FCT52/53T
- Industrial temperature  $-40^{\circ}\text{C}$  to  $85^{\circ}\text{C}$
- CMOS power levels:  $<7.5\text{mW}$  static
- Available in DIP, ZIP, SOIC, QSOP, HQSOP
- Undershoot clamp diodes on all inputs
- TTL-compatible input and output levels
- Ground bounce controlled outputs
- Reduced output swing of 0-3.5V
- Military product compliant to MIL-STD-883, Class B

### FCT-T 2952T, 2953T

- JEDEC-FCT spec compatible
- A, B, and C speed grades with  $5.5\text{ns}$   $t_{PD}$  for C
- $I_{OL} = 64\text{mA}$  Ind.,  $48\text{mA}$  Mil.

### FCT-T 2052T

- Built-in  $25\Omega$  series resistor outputs reduce reflection and other system noise
- A, B, and C speed grades with  $5.5\text{ns}$   $t_{PD}$  for C speed guaranteed with  $50\text{pF}$  loads

## DESCRIPTION

The QS29FCT52/53T are 8-bit high-speed CMOS TTL-compatible registered bus transceivers with three-state outputs that are ideal for driving high capacitance loads such as memory and address buses. The QS29FCT2052T device is a  $25\Omega$  resistor output version useful for driving transmission lines and reducing system noise. The FCT2052 series part can replace the FCT52/FCT53 series to reduce noise in an existing design. All inputs have clamp diodes for undershoot noise suppression. All outputs have ground bounce suppression, and will not load an active bus when  $V_{CC}$  is removed from the device.

**Figure 1. Functional Block Diagram**

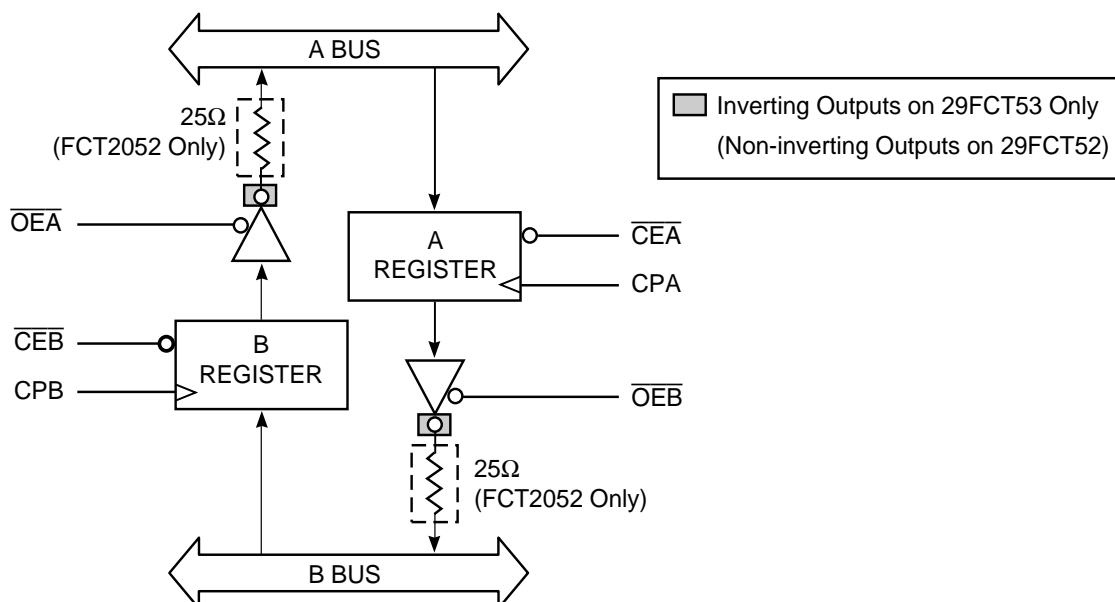
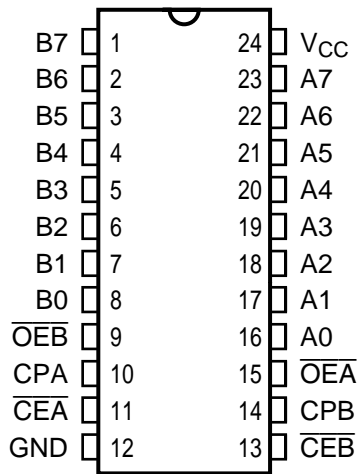

Figure 2. Pin Configurations (All Pins Top View)

PDIP, SOIC, QSOP, HQSOP



ZIP

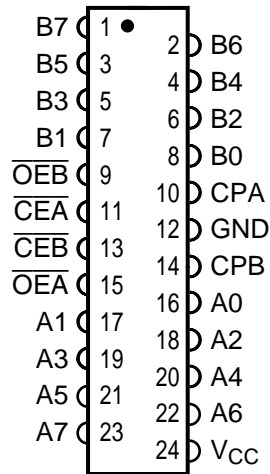

Table 1. Pin Description

Name	I/O	Description
A7-A0	I/O	A Bus
B7-B0	I/O	B Bus
CPA	I	Register A Clock Input
CPB	I	Register B Clock Input
$\overline{\text{CEA}}$	I	Register A Clock Enable
$\overline{\text{CEB}}$	I	Register B Clock Enable
$\overline{\text{OEA}}$	I	Output Enable, Reg. B to Bus A
$\overline{\text{OEB}}$	I	Output Enable, Reg. A to Bus B

Table 2. Function Tables

Inputs						Outputs	
CPA	CPB	$\overline{CEA}$	$\overline{CEB}$	$\overline{OEA}$	$\overline{OEB}$	A7-A0	B7-B0
X	X	X	X	H	L	Hi-Z	Reg. A
X	X	X	X	L	H	Reg. B	Hi-Z
X	X	X	X	H	H	Hi-Z	Hi-Z
X	X	X	X	L	L	Reg. B	Reg. A

Inputs				Outputs	
CPA	CPB	$\overline{CEA}$	$\overline{CEB}$	A7-A0	B7-B0
X	X	H	H	Hold	Hold
↑	X	L	H	Load	Hold
X	↑	H	L	Hold	Load
X	↑	L	L	X	Load
↑	X	L	L	Load	X

Table 3. Absolute Maximum Ratings

Supply Voltage to Ground .....	-0.5V to 7.0V
DC Output Voltage $V_{OUT}$ .....	-0.5V to 7.0V
DC Input Voltage $V_{IN}$ .....	-0.5V to 7.0V
AC Input Voltage (for a pulse width $\leq 20$ ns) .....	-3.0V
DC Input Diode Current with $V_{IN} < 0$ .....	-20mA
DC Output Diode Current with $V_{OUT} < 0$ .....	-50mA
DC Output Current Max. Sink Current/Pin .....	120mA
Maximum Power Dissipation .....	0.5 watts
$T_{STG}$ Storage Temperature .....	-65° to 150°C

**Note:** Stresses greater than those listed under ABSOLUTE MAXIMUM RATINGS may cause permanent damage to this device resulting in functional or reliability type failures.

Table 4. Capacitance<sup>(1)</sup>

$T_A = 25^\circ\text{C}$ ,  $f = 1\text{MHz}$ ,  $V_{IN} = 0\text{V}$ ,  $V_{OUT} = 0\text{V}$

Pins <sup>(2)</sup>	SOIC	QSOP	PDIP	ZIP	Unit
1-11, 13-23	8	8	9	10	pF

**Notes:**

1. Capacitance is characterized but not tested.
2. Pin reference for 24-pin package.

**QS29FCT52T, 53T, 2052T**

**Table 5. DC Electrical Characteristics Over Operating Range**

Industrial  $T_A = -40^{\circ}\text{C}$  to  $85^{\circ}\text{C}$ ,  $V_{CC} = 5.0\text{V} \pm 5\%$

Military  $T_A = -55^{\circ}\text{C}$  to  $125^{\circ}\text{C}$ ,  $V_{CC} = 5.0\text{V} \pm 10\%$

Symbol	Parameter	Test Conditions	Min	Typ <sup>(1)</sup>	Max	Unit
$V_{IH}$	Input HIGH Voltage	Logic HIGH for All Inputs	2.0	—	—	V
$V_{IL}$	Input LOW Voltage	Logic LOW for All Inputs	—	—	0.8	V
$\Delta V_T$	Input Hysteresis	$V_{TLH} - V_{THL}$ for All Inputs	—	0.2	—	V
$ I_{IH} $ $ I_{IL} $	Input Current Input HIGH or LOW	$V_{CC} = \text{Max.}, 0 \leq V_{IN} < V_{CC}$	—	—	5	$\mu\text{A}$
$ I_{OZ} $	Off-State Output Current (Hi-Z)	$V_{CC} = \text{Max.}, 0 \leq V_{IN} \leq V_{CC}$	—	—	5	$\mu\text{A}$
$I_{OS}$	Short Circuit Current (FCTXXX)	$V_{CC} = \text{Max.}, V_{OUT} = \text{GND}^{(2,3)}$	-60	—	—	mA
$I_{OR}$	Current Drive (FCT2XXX - 25 $\Omega$ )	$V_{CC} = \text{Max.}, V_{OUT} = 2.0\text{V}^{(3)}$	50	—	—	mA
$V_{IC}$	Input Clamp Voltage	$V_{CC} = \text{Min.}, I_{IN} = -18\text{mA}, T_A = 25^{\circ}\text{C}^{(3)}$	—	-0.7	-1.2	V
$V_{OH}$	Output HIGH Voltage	$V_{CC} = \text{Min.}, I_{OH} = -12\text{mA (MIL)}$ $I_{OH} = -15\text{mA (IND)}$	2.4 2.4	— —	— —	V
$V_{OL}$	Output LOW Voltage (FCTXXX)	$V_{CC} = \text{Min.}, I_{OL} = 48\text{mA (MIL)}$ $I_{OL} = 64\text{mA (IND)}$	— —	— —	0.55 0.55	V
$V_{OL}$	Output LOW Voltage (FCT2XXX - 25 $\Omega$ )	$V_{CC} = \text{Min.}, I_{OL} = 12\text{mA (MIL)}$ $I_{OL} = 12\text{mA (IND)}$	— —	— —	0.50 0.50	V
$R_{OUT}$	Output Resistance (FCT2XXX - 25 $\Omega$ )	$V_{CC} = \text{Min.}, I_{OL} = 12\text{mA (MIL)}$ $I_{OL} = 12\text{mA (IND)}$	— 20	25 28	— 40	$\Omega$

**Notes:**

1. Typical values indicate  $V_{CC} = 5.0\text{V}$  and  $T_A = 25^{\circ}\text{C}$ .
2. Not more than one output should be shorted and the duration is  $\leq 1$  second.
3. These parameters are guaranteed by design but not tested.

**Table 6. Power Supply Characteristics**

Symbol	Parameter	Test Conditions <sup>(1)</sup>	Min	Max	Unit
$I_{CC}$	Quiescent Power Supply Current	$V_{CC} = \text{Max.}$ , freq = 0 $0V \leq V_{IN} \leq 0.2V$ or $V_{CC}-0.2V \leq V_{IN} \leq V_{CC}$	—	1.5	mA
$\Delta I_{CC}$	Supply Current per Input @ TTL HIGH	$V_{CC} = \text{Max.}$ , $V_{IN} = 3.4V$ , freq = 0 <sup>(2)</sup>	—	2.0	mA
$Q_{CCD}$	Supply Current per Input per MHz	$V_{CC} = \text{Max.}$ , Outputs Open and Enabled One Bit Toggling @ 50% Duty Cycle Other Inputs at GND or $V_{CC}$ <sup>(3,4)</sup>	—	0.25	mA/ MHz

**Notes:**

1. For conditions shown as Min. or Max., use the appropriate values specified under DC specifications.
2. Per TTL driven input ( $V_{IN} = 3.4V$ ).
3. For flip-flops,  $Q_{CCD}$  is measured by switching one of the data input pins so that the output changes every clock cycle. This is a measurement of device power consumption only and does not include power to drive load capacitance or tester capacitance. This parameter is guaranteed by design but not tested.
4.  $I_C$  can be computed using the above parameters as explained in the Technical Overview section.

Now an  IDT™ company

**QS29FCT52T, 53T, 2052T**

**Table 7. Switching Characteristics Over Operating Range**

Industrial  $T_A = -40^\circ\text{C}$  to  $70^\circ\text{C}$ ,  $V_{CC} = 5.0\text{V} \pm 5\%$       Military  $T_A = -55^\circ\text{C}$  to  $125^\circ\text{C}$ ,  $V_{CC} = 5.0\text{V} \pm 10\%$   
 $C_{LOAD} = 50\text{pF}$ ,  $R_{LOAD} = 500\Omega$  unless otherwise noted.

Symbol	Description		52/53A 2052A		52/53B 2052B		52/53C 2052C		Unit
			Min	Max	Min	Max	Min	Max	
$t_{PHL}$	Propagation Delay <sup>(1)</sup>	Ind	2	10	2	6.5	2	5.8	ns
$t_{PLH}$	CP to Ai, Bi, 52/53	Mil	2	11	2	7.2	0	6.8	
$t_{PHL}$	Propagation Delay <sup>(1)</sup>	Ind	2	10	2	6.5	2	5.8	ns
$t_{PLH}$	CP to Ai, Bi, 2052	Mil	2	11	2	7.2	0	6.8	
$t_{PZH}$	Output Enable Time <sup>(1)</sup>	Ind	1.5	10.5	1.5	6.5	1.5	6.5	ns
$t_{PZL}$	$\overline{OE}$ to Ai, Bi, 52/53	Mil	1.5	13	1.5	7.5	1.5	7.5	
$t_{PZH}$	Output Enable Time <sup>(1)</sup>	Ind	1.5	10.5	1.5	7.0	1.5	7.0	ns
$t_{PZL}$	$\overline{OE}$ to Ai, Bi, 2052	Mil	1.5	13	1.5	7.5	1.5	7.5	
$t_{PHZ}$	Output Disable Time <sup>(1,2)</sup>	Ind	2	10	2	5.5	1.5	5.5	ns
$t_{PLZ}$	$\overline{OE}$ to Ai, Bi	Mil	2	11	2	6.5	1.5	6.5	
$t_S$	Data Setup Time Ai, Bi, to CP	Ind	2	—	2	—	2	—	ns
		Mil	2.5	—	2	—	2	—	
$t_H$	Data Hold Time Ai, Bi, to CP	Ind	2	—	1.5	—	1.5	—	ns
		Mil	2	—	1.5	—	1.5	—	
$t_{SCE}$	Clock Enable Setup Time, $\overline{CE}$ to CP	Ind	2	—	2	—	2	—	ns
		Mil	2	—	2	—	2	—	
$t_{HCE}$	Clock Enable Hold Time, $\overline{CE}$ to CP	Ind	2	—	2	—	2	—	ns
		Mil	2	—	2	—	2	—	
$t_W$	Clock Pulse Width <sup>(2)</sup> HIGH or LOW	Ind	3	—	3	—	3	—	ns
		Mil	3	—	3	—	3	—	

**Notes:**

1. Minimums guaranteed but not tested.
2. This parameter is guaranteed by design but not tested.
3. See Test Circuit and Waveforms.