

REV	ECN	APP'D
A	6689	

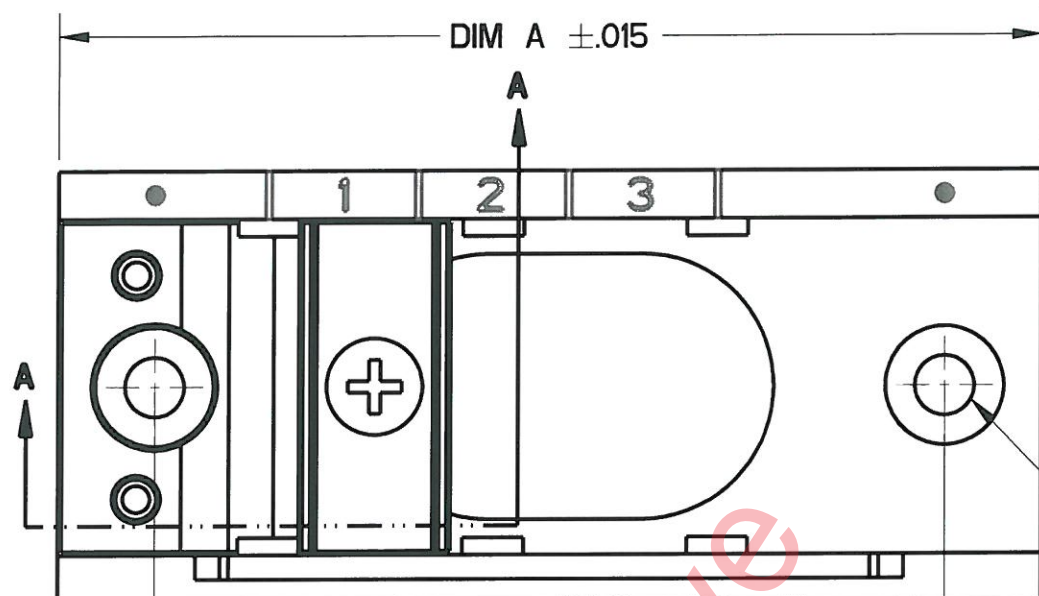

NOTES:

- MATERIALS AND FINISH
 TRACK, LOCKING CLAMP, AND END STOP - ALUMINUM ALLOY 6063
 TEMPER T5, PER FED SPEC. QQ-A-200/9, BLACK ANODIZE PER MIL-A-8625
 TYPE II, CLASS 2.
 LOCKING CLAMP SCREW - CORROSION RESISTANT, PASSIVATED, SELF-LOCKING.
 RIVETS - ALUMINUM ALLOY #2117, CHROMATE PER MIL-DTL-5541, CLASS 1A, YELLOW.
- APCD P/N TJT703003 (M81714/16-2) SHOWN.

Ø.154 MOUNTING HOLES
 CSK 82° X .307 DIA
 4X

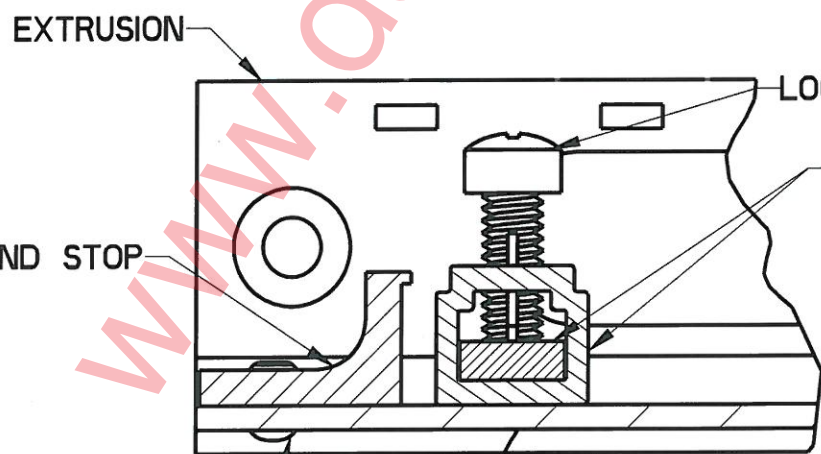
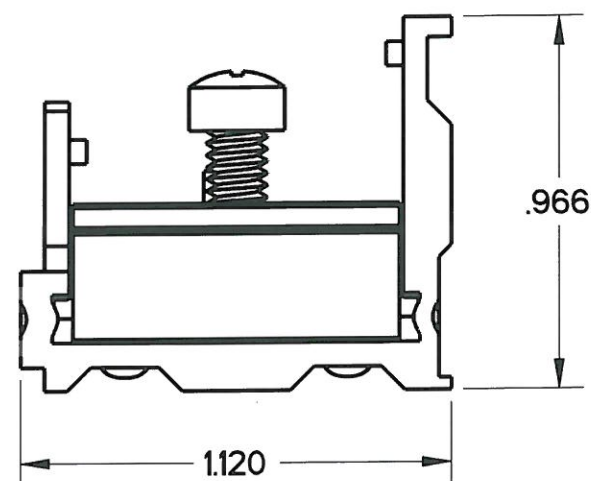
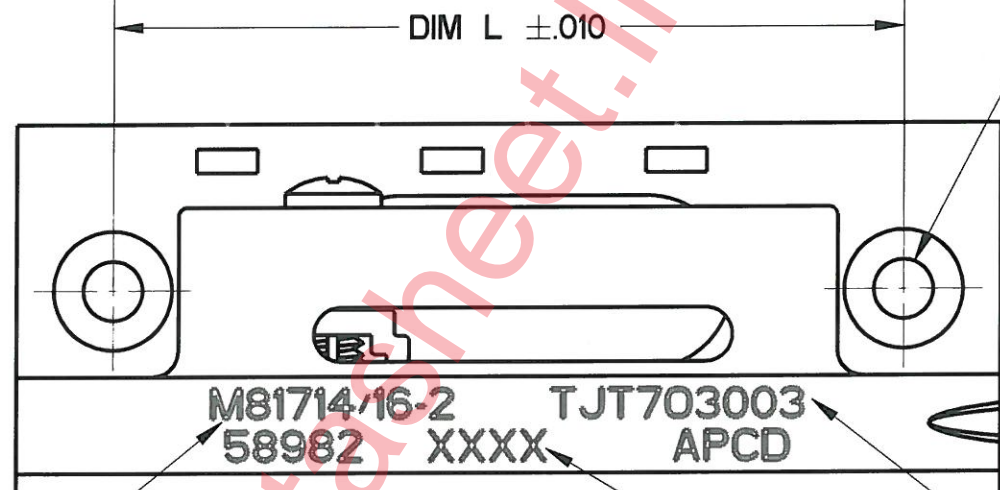

2X RIVET (HEADS ON BOTTOM)

* DIVIDE BY 3 FOR SIZE 12 MODULE MOUNTING

MIL P/N	APCD P/N	MTG POS.	DIM A	DIM L
M81714/16-1	TJT703010	10	5.291	4.791
M81714/16-2	TJT703003	3	2.561	2.061
M81714/16-3	TJT703004	4	2.951	2.451
M81714/16-4	TJT703005	5	3.341	2.841
M81714/16-5	TJT703006	6	3.731	3.231
M81714/16-6	TJT703007	7	4.121	3.621
M81714/16-7	TJT703008	8	4.511	4.011
M81714/16-8	TJT703009	9	4.901	4.401
M81714/16-9	TJT703011	11	5.681	5.181
M81714/16-10	TJT703012	12	6.071	5.571
M81714/16-11	TJT703013	13	6.461	5.961
M81714/16-12	TJT703014	14	6.851	6.351
M81714/16-13	TJT703015	15	7.241	6.741

DIMENSIONS ANSI Y14.5M UNITS: INCHES Pro/E FILE	TOLERANCES .XX ±0.01 .XXX ±0.005 ANGLES ±2.0°	PROJECTION 	Amphenol Pcd SPECIFICATION DRAWING	
			ENGR M.Hai 12-Apr-11	
ORIGINAL 	THIS DOCUMENT CONTAINS PROPRIETARY INFORMATION WHICH IS THE CONFIDENTIAL PROPERTY OF AMPHENOL PCD INC. BEVERLY, MA, USA		CHKD 4/18/11	TITLE TERMINAL JUNCTION MOUNTING TRACK M81714/16, SERIES I
			APPD 4/20/11	SIZE B DWG NO. TJT703003

CODE: 58982	SCALE: 2:1	SHEET 1 OF 1
-------------	------------	--------------