



MIL-C 26482G Series II

Applications

For all general purposes in military applications

Standards

MIL-C 26482 Series II
QPL approved



Description

- Standard version
- Aluminum alloy
olive green, nickel or, black, anodized plating
- Bayonet coupling
- RFI shielding plug
- Gold plating crimp contacts # 20, 16, and # 12
- # 16 and # 12 minicoaxial or thermocouple contacts
- Hermetic version available
- Light weight backshells

Characteristics

Mechanical

- Endurance : 500 operations
- Plug MS 3475 : 250 operations
- Plug MS 3476 : 500 operations
- Shock : 300 g - 3 ms in three axes
- Vibration : MIL STD 202, method 214, test condition II, letter J (50 - 2000Hz; 41,7 g eff.)
- Contact retention in insert :
 - size 20 : 90 N
 - size 16 : 111 N
 - size 12 : 133 N

Electrical

- Max. current rating per contact

	environmental class	hermetic class
size 20	7,5 A	5 A
size 16	13 A	10 A
size 12	23 A	17 A

- Contact resistance

	environmental class	hermetic class
size 20	≤ 1 mΩ	≤ 7 mΩ
size 16	≤ 0,55 mΩ	≤ 3,8 mΩ
size 12	≤ 0,35 mΩ	≤ 2,4 mΩ

- Insulation resistance :
≥ 5000 MΩ at 500 Vdc

- Dielectric withstanding voltage

Service	I	II
at ground level	1500 Vrms	2300 Vrms
at 21000 m	375 Vrms	550 Vrms

- Shell continuity with plug MS 3475,
environmental receptacle ≤ 5 mΩ,
hermetic receptacle ≤ 50 mΩ

Climatical

- Operating temperature :
-55°C to + 200°C (class L)
-55°C to + 175°C (classes W and H)
- Damp heat : MIL STD 1344
method 1002 - Type II
- Salt spray :
class W : 500 hr
class L : 48 hr
- Leakage :
environmental version :
- when mated under a differential pressure of 1,03 bar. air leakage is ≤ 3,6 mm³/h
- low pressure immersion : 33 mbar
hermetic version :
- differential pressure of 1 bar air/helium, leakage is ≤ 2,8 mm³/h

Resistance to fluids

MIL-L 7808
MIL-L 23699
MIL-H 5606
Hydraulic fluids M 2 V
MIL-C 25769 diluted
MIL-A 8243
MIL-T 5624 (JP5)
MIL-G 3056
Solvents

Ordering information environmental connectors

basic series		MS	3470	W	••	••	P	•
shell type	3470 - square flange receptacle 3474 - jam nut receptacle 3475 - RFI shielded plug 3476 - plug							
class and plating	W - olive green cadmium L - nickel							
shell size	8-10-12-14-16-18-20-22-24							
contact layout	- see table p 59							
contact type	P - male contact S - female contact A - less male contact B - less female contact							
polarization	N - normal (not included in part number) W, X, Y and Z - see table p 60							



MIL-C 26482G Series II

Hermetic connectors

basic series	MS 3440 H •• C •• P •
shell type	3440 - square flange receptacle 3443 - solder fixing receptacle 3449 - jam nut receptacle
class	H - hermetic
shell size	8-10-12-14-16-18-20-22-24
materials and terminal	C - steel, solder bucket
contact layout	see table p 59
contact type	male only
polarization	N - normal (not included in part number) W, X, Y and Z - see table p 60

Backshells

Backshell type	Plating			MIL-C 26482G Series II	SOURIAU
	A	W	N		
Backnut	•	•	•	M85049-31-••A M85049-31-••W -	852-31A•• 852-31W•• 852-31N••
Straight cable clamp	•	•	•	M85049-52-1••A M85049-52-1••W -	852-52A•• 852-52W•• 852-52N••
Elbow cable clamp	•	•	•	M85049-51-1••A M85049-51-1••W -	852-51A•• 852-51W•• 852-51N••
Straight backshell for heatshrink sleeving	•	•	•	M85049-60-1A•• M85049-60-1W•• -	852-60A•• 852-60W•• 852-60N••
Backnut for heatshrink sleeving	•	•	•	- - -	852-57A•• 852-57W•• 852-57N••

A - black anodized

W - olive green cadmium

N - nickel

Example : M85049-31-8A
 852-31A08
 └──┬──┘ shell size

Cross reference list

Part number cross reference list SOURIAU and MIL-C 26482G Series II

MIL-C 26482G Series II	SOURIAU	Designation
MS3470 W•••• P □	8526-0W•••• P □	square flange receptacle with male contacts
MS3470 W•••• A □	8526-0W•••• P □ L	square flange receptacle less male contacts
MS3470 W•••• S □	8526-0W•••• S □	square flange receptacle with female contacts
MS3470 W•••• B □	8526-0W•••• S □ L	square flange receptacle less female contacts
MS3474 W•••• P □	8526-7W•••• P □	jam nut receptacle with male contacts
MS3474 W•••• A □	8526-7W•••• P □ L	jam nut receptacle less male contacts
MS3474 W•••• S □	8526-7W•••• S □	jam nut receptacle with female contacts
MS3474 W•••• B □	8526-7W•••• S □ L	jam nut receptacle less female contacts
MS3475 W•••• P □	8526-5W•••• P □	BFI shielded plug with male contacts



MIL-C 26482G Series II

MIL-C 26482G Series II	FCI Souriau	Designation
MS3475 W A <input type="checkbox"/> MS3475 W S <input type="checkbox"/> MS3475 W B <input type="checkbox"/> MS3476 W P <input type="checkbox"/> MS3476 W A <input type="checkbox"/> MS3476 W S <input type="checkbox"/> MS3476 W B <input type="checkbox"/> MS3470 L P <input type="checkbox"/> MS3470 L A <input type="checkbox"/> MS3470 L S <input type="checkbox"/> MS3470 L B <input type="checkbox"/> MS3474 L P <input type="checkbox"/> MS3474 L A <input type="checkbox"/> MS3474 L S <input type="checkbox"/> MS3474 L B <input type="checkbox"/> MS3475 L P <input type="checkbox"/> MS3475 L A <input type="checkbox"/> MS3475 L S <input type="checkbox"/> MS3475 L B <input type="checkbox"/> MS3476 L P <input type="checkbox"/> MS3476 L A <input type="checkbox"/> MS3476 L S <input type="checkbox"/> MS3476 L B <input type="checkbox"/>	8526-5W P <input type="checkbox"/> L 8526-5W S <input type="checkbox"/> 8526-5W S <input type="checkbox"/> L 8526-6W P <input type="checkbox"/> 8526-6W P <input type="checkbox"/> L 8526-6W S <input type="checkbox"/> 8526-6W S <input type="checkbox"/> L 8526-0L P <input type="checkbox"/> 8526-0L P <input type="checkbox"/> L 8526-0L S <input type="checkbox"/> 8526-0L S <input type="checkbox"/> L 8526-7L P <input type="checkbox"/> 8526-7L P <input type="checkbox"/> L 8526-7L S <input type="checkbox"/> 8526-7L S <input type="checkbox"/> L 8526-5L P <input type="checkbox"/> 8526-5L P <input type="checkbox"/> L 8526-5L S <input type="checkbox"/> 8526-5L S <input type="checkbox"/> L 8526-6L P <input type="checkbox"/> 8526-6L P <input type="checkbox"/> L 8526-6L S <input type="checkbox"/> 8526-6L S <input type="checkbox"/> L	RFI shielded plug less male contacts RFI shielded plug with female contacts RFI shielded plug less female contacts plug with male contact plug less male contact plug with female contact plug less female contact square flange receptacle with male contacts square flange receptacle less male contacts square flange receptacle with female contacts square flange receptacle less female contacts jam nut receptacle with male contacts jam nut receptacle less male contacts jam nut receptacle with female contacts jam nut receptacle less female contacts RFI shielded plug with male contacts RFI shielded plug less male contacts RFI shielded plug with female contacts RFI shielded plug less male contacts plug with male contact plug less male contact plug with female contact plug with less female contact
MS3440 H .. C .. P <input type="checkbox"/> MS3443 H .. C .. P <input type="checkbox"/> MS3449 H .. C .. P <input type="checkbox"/>	8526-2H P <input type="checkbox"/> 8526-1H P <input type="checkbox"/> 8526-7H P <input type="checkbox"/>	hermetic square flange receptacle hermetic solder fixing receptacle hermetic jam nut receptacle
M85049/31- .. W M85049/52-1- .. W M85049/51-1- .. W M85049/60-1W- .. M85049/60-2G- .. A M85049/31- .. A M85049/52-1- .. A M85049/51-1- .. A M85049/60-1A .. M85049/60-2G- .. A M85049/31- .. N M85049/52-1- .. N M85049/51-1- .. N M85049/60-1N .. M85049/60-2G- .. N	852-31W .. 852-52W .. 852-51W .. 852-60W .. *852-57W .. 852-31A .. 852-52A .. 852-51A .. 852-60A .. *852-57A .. *852-31N .. *852-52N .. *852-51N .. *852-60N .. *852-57N ..	backnut straight cable clamp elbow cable clamp backshell for heatshrink sleeving backnut for heatshrink sleeving backnut straight cable clamp elbow cable clamp backshell for heatshrink sleeving backnut for heatshrink sleeving backnut straight cable clamp elbow cable clamp backshell for heatshrink sleeving backnut for heatshrink sleeving
M39029/4-110 M39029/4-111 M39029/4-113 M39029/5-115 M39029/5-116 M39029/5-118 M39029/9-135 M39029/9-134 M39029/10-141 M39029/10-140 M39029/9-129 M39029/7-126	8522-486A 900 8522-487B 900 *8522-875A *8522-876A *8522-877A 900 *8522-878B 900 *8526-12-1-001 *8526-12-2-001	male contact # 20 male contact # 16 male contact # 12 female contact # 20 female contact # 16 female contact # 12 thermocouple contacts male-chromel # 20 male-alumel # 20 female-chromel # 20 female-alumel # 20 coax contacts # 12 female for RG178B/U cable male for RG178B/U cable
MS27488-20 MS27488-16 MS27488-12 M81969-14-02 M81696-14-03 M81696-14-04	8522-389A 8522-390A 8522-391A 8522-20 8522-16 8522-12	filler plug # 20 filler plug # 16 filler plug # 12 plastic tool for contact # 20 plastic tool for contact # 16 plastic tool for contact # 12

MIL-C 26482G Series II



Contacts layouts viewed from front face of male insulator

Shells								
08	10	12	14	16	18	20	22	24
8-33*	10-6*	12-10*	14-19*	16-26*	18-32*	20-41*	22-55*	24-61*
3 # 20	6 # 20	10 # 20	19 # 20	26 # 20	32 # 20	41 # 20	55 # 20	61 # 20
8-98*		12-3*	14-15*	16-8*	18-11	20-39*	22-41*	24-31
3 # 20		3 # 16	14 # 20 1 # 16	8 # 16	11 # 16	37 # 20 2 # 16	27 # 20 14 # 16	31 # 16
			14-12*		18-8*	20-16*	22-21*	24-19
			8 # 20 4 # 16		8 # 12	16 # 16	21 # 16	19 # 12
			14-5*				22-12	
			5 # 16				12 # 12	
			14-4*					
			4 # 12					

* hermetic receptacle available
not QPL to date



MIL-C 26482G Series II

Polarization

Insulator rotated inside metal body

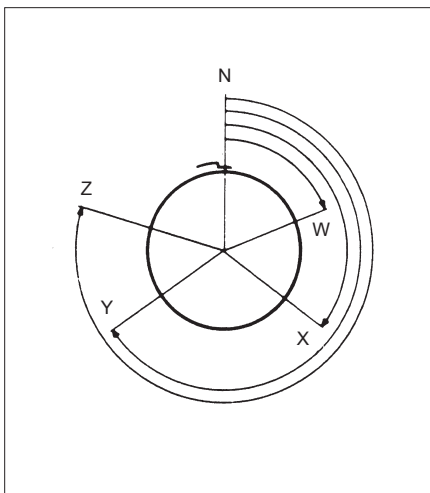

shell size	contacts layouts	service I	service II	number of contacts			angles in degrees				
				size 20 Ø1	size 16 Ø1,6	size 12 Ø2,4	N	W	X	Y	Z
8	8-33	X		3			0	90	-	-	-
	8-98	X		3			0	-	-	-	-
10	10-6	X		6			0	90	-	-	-
	12-10	X		10			0	60	155	270	295
12	12-3		X		3		0	-	-	180	-
	14-19	X		19			0	30	165	315	-
14	14-15	X		14	1		0	17	110	155	234
	14-12	X		8	4		0	43	90	-	-
	14-5		X		5		0	40	92	184	273
	14-4	X	X			4	0	45	-	-	-
								0	-	-	-
16	16-26	X		26			0	60	-	275	338
	16-8		X		8		0	54	152	180	331
18	18-32	X		32			0	85	138	222	265
	18-11	X	X		11		0	62	119	241	340
	18-8	X				8	0	180	-	-	-
20	20-41	X		41			0	45	126	225	-
	20-39	X		37	2		0	63	144	252	333
	20-16		X		16		0	238	318	333	347
22	22-55	X		55			0	30	142	226	314
	22-41	X		27	14		0	39	135	264	-
	22-21		X		21		0	16	135	175	349
	22-12	X				12	0	-	-	-	-
24	24-61	X		61			0	90	180	270	324
	24-31	X			31		0	90	225	255	-
	24-19		X			19	0	30	165	315	-

Contacts

Contacts size	20 (Ø1mm)	16 (Ø1.6mm)	12 (Ø2.4mm)
Cable accommodation (admissible section)			
external Ø over insulator	0,98/2,11 mm	1,34/2,62 mm	2,45/4,01 mm
admissible section	0,21/0,60 mm ²	0,60/1,34mm ²	1,91/3,18mm ²
wire gauge	24/20	20/16	14/12
reducing sleeve for wire of	0,09/0,21 mm ²	-	-
	28/24	-	-
part numbers			
- male contacts colour code	M39029/4-110 brown-brown-black	M39029/4-111 brown-brown-brown	M39029/4-113 brown-brown-orange
- female contacts colour code	M39029/5-115 brown-brown-green	M39029/5-116 brown-brown-blue	M39029/5-118 brown-brown-grey
- male contacts chromel thermocouple colour code	8522-875 A brown-orange-green	8522-881 yellow	8522-887 yellow
- alumel thermocouple colour code	8522-876 A brown-orange-yellow	8522-882 black	8522-888 black
- female contacts chromel thermocouple colour code	8522-877 A brown-yellow-brown	8522-883 yellow	8522-889 yellow
- alumel thermocouple colour code	8522-878 A brown-yellow-black	8522-884 black	8522-890 black
reducing sleeve	8522-2142		

Minicoax contacts

installed instead of size 16 contacts

male contacts	16 (Ø1.6mm)	12 (Ø2.4mm)	12 (Ø2.4mm)
	8526-2-001 A	8526-2-002 A	8526-2-003 A
female contacts			
	8526-1-001 A	8526-1-002 A	8526-1-003 A
cables accepted	RG-316U-KX 22 A	RG-178 B/U-KX 21 A	RG 179 B/U

Coax contacts

installed instead of size 12 contacts

male contacts	12 (Ø2.4mm)	12 (Ø2.4mm)	12 (Ø2.4mm)	12 (Ø2.4mm)
	8526-12-2-001	8526-12-2-002	8526-12-2-003	8526-12-2-004
female contacts				
	8526-12-1-001	8526-12-1-002	8526-12-1-003	8526-12-1-004
cables accepted	RG 178 B/U	RG 179 B/U	RG 316 U	RG 180 B/U

MIL-C 26482G Series II



Dimensions

Plug MS3475 and MS3476

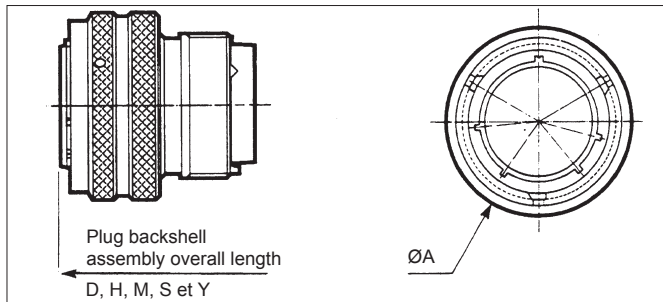

shells	A	B Max	C	D Max	E min	E Max	F Max	G Max	H Max
08	18.95 .746	15.65 .616	6.75 .266	36.5 1.437	3.2 .126	5.2 .205	19.1 .752	22.65 .892	46.1 1.815
10	22.65 .892	18.6 .732	9.4 .370	36.5 1.437	4.75 .187	7.25 .285	21.1 .831	24.45 .963	47.59 2.669
12	25.75 1.014	21.75 .856	12.8 .504	36.5 1.014	7.4 .856	10.6 .504	25.1 1.437	27.85 .291	51.3 .417
14	29.75 1.171	24.95 .982	14.75 .581	36.5 1.437	8.9 .350	12.1 .476	26.6 1.047	27.85 1.096	51.3 2.394
16	32.95 1.297	28.2 1.110	17.93 .706	36.5 1.437	12.75 .502	15.9 .626	33.5 1.319	30.85 1.215	54.3 2.138
18	35.35 1.392	30.9 1.217	19.94 .785	36.5 1.437	13.15 .518	17.9 .705	36.9 1.453	37.85 1.490	60.8 2.394
20	38.75 1.526	34.15 1.344	23.11 .910	36.5 1.437	14.75 .581	21.1 .831	39.5 1.555	40.45 1.593	63.9 2.516
22	41.85 1.648	37.25 1.467	26.29 1.035	36.5 1.437	16.35 .644	24.3 .957	42 1.654	44.35 1.746	67.8 2.669
24	45.05 1.774	40.45 1.593	29.2 1.150	36.5 1.437	17.95 .707	27.5 1.083	45.1 1.776	46.75 1.841	70.2 2.764

shells	J Max	K min	K Max	L Max	M Max	N mini	O Max	P	Q Max
08	20.5 .807	3.2 .126	5.2 .205	27.6 1.087	52.2 2.055	6.75 .266	13.5 .531	3.3 .130	10.6 .417
10	22 .866	4.75 .185	7.25 .285	29.3 1.154	53.9 2.122	9.4 .370	15.35 .604	3.3 .130	10.6 .417
12	23.6 .929	7.4 .291	10.6 .417	31.9 1.256	56.5 2.224	12.8 .504	19.65 .774	3.3 .130	10.6 .417
14	25.2 .992	8.9 .350	12.1 .476	33.4 1.315	58 2.283	14.75 .581	21.25 .837	3.3 .130	10.6 .417
16	26.8 1.055	12.75 .502	15.9 .626	37.3 1.469	61.9 2.437	17.93 .706	24.45 .963	3.3 .130	10.6 .417
18	31.3 1.232	13.15 .518	17.9 .705	38.7 1.524	63.3 2.492	19.94 .785	26.45 1.041	3.3 .130	10.6 .417
20	32.9 1.295	14.75 .581	21.1 .831	40.25 1.585	64.9 2.555	23.11 .910	30.9 1.217	3.3 .130	10.6 .417
22	34.5 1.358	16.35 .644	24.3 .957	41.9 1.650	66.5 2.618	26.29 1.035	34.4 1.354	3.3 .130	10.6 .417
24	36.1 1.421	17.95 .707	27.5 1.083	43.5 1.713	68.1 2.681	29.2 1.150	36.65 1.443	3.3 .130	10.6 .417

shells	R Max	S Max	T Max	U Max	V	W Max	X Max	Y Max
08	28.55 1.124	52 2.047	13.72 .540	6.75 .266	17.48 .688	3.3 .130	10.5 .413	37.4 1.472
10	28.55 1.124	52 2.047	13.72 .540	9.4 .370	20.4 .803	3.3 .130	10.5 .413	37.4 1.472
12	28.55 1.124	52 2.047	13.72 .540	12.8 .504	23.83 .938	3.3 .130	10.5 .413	37.4 1.472
14	28.55 1.124	52 2.047	13.72 .540	14.75 .581	27 1.063	3.3 .130	10.5 .413	37.4 1.472
16	28.55 1.124	52 2.047	13.72 .540	17.93 .706	31.45 1.238	3.3 .130	10.5 .413	37.4 1.472
18	28.55 1.124	52 2.047	13.72 .540	19.94 .785	33.27 1.310	3.3 .130	10.5 .413	37.4 1.472
20	28.55 1.124	52 2.047	13.72 .540	23.11 .910	36.47 1.436	3.3 .130	10.5 .413	37.4 1.472
22	28.55 1.124	52 2.047	13.72 .540	26.29 1.035	39.62 1.560	3.3 .130	10.5 .413	37.4 1.472
24	28.55 1.124	52 2.047	13.72 .540	29.2 1.150	42.82 1.686	3.3 .130	10.5 .413	37.4 1.472

Backshells

backnut
type 31

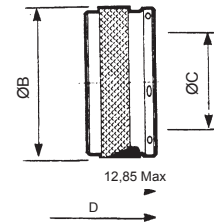

Straight
cable clamp
type 52-1

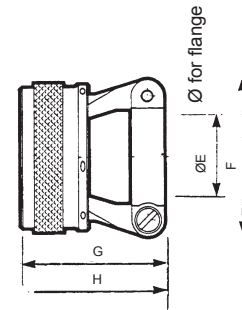

elbow
cable clamp
type 51-1

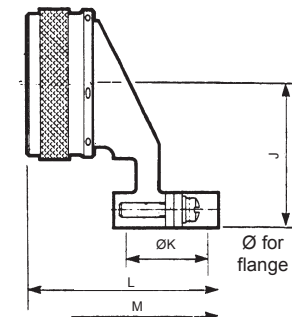

for heatshrink
sleeving
type 60-1

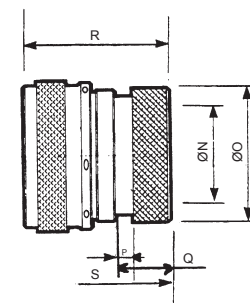

backnut for
heatshrink
sleeving
type 60-2

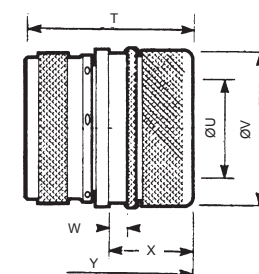



MIL-C 26482G Series II

Environmental square flange receptacle MS3470

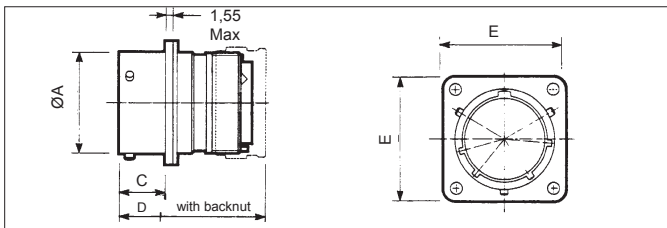

panel cut-out

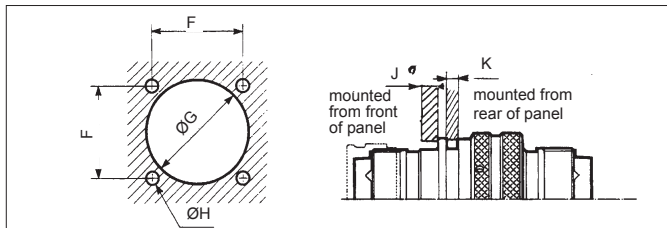

shells	A	B	C	D	E	F	G	H	J	K
	Max	Max	Max	Max	Max				Max	Max
08	12.03 .474	1.95 .077	11.7 .461	36.5 1.437	21 .827	15.09 .594	14.43 .568	3.05 .120	3.17 .125	2.21 .087
10	15.01 .591	1.95 .077	11.7 .461	36.5 1.437	24.2 .953	18.26 .719	17.4 .685	3.05 .120	3.17 .125	2.21 .087
12	19.07 .751	1.95 .077	11.7 .461	36.5 1.437	26.55 1.045	20.62 .812	21.95 .864	3.05 .120	3.17 .125	2.21 .087
14	22.25 .876	1.95 .077	11.7 .461	36.5 1.437	28.9 1.138	23.01 .906	25.12 .989	3.05 .120	3.17 .125	2.21 .087
16	25.42 1.001	1.95 .077	11.7 .461	36.5 1.437	31.3 1.232	24.61 .969	28.27 1.113	3.05 .120	3.17 .125	2.21 .087
18	28.6 1.126	1.95 .077	11.7 .461	36.5 1.437	33.7 1.327	26.97 1.062	31.45 1.238	3.05 .120	3.17 .125	2.21 .087
20	31.77 1.251	2.75 .108	14.35 .565	38.1 1.500	36.9 1.453	29.36 1.156	34.62 1.363	3.05 .120	3.17 .125	5.38 .212
22	34.95 1.376	2.75 .108	14.35 .565	38.1 1.500	40 1.575	31.75 1.250	37.8 1.488	3.05 .120	3.17 .125	5.38 .212
24	38.12 1.501	2.75 .108	15.2 .598	38.1 1.500	43.3 1.705	34.92 1.375	41.02 1.615	3.73 .147	3.17 .125	5.38 .212

Environmental jam nut receptacle MS3474

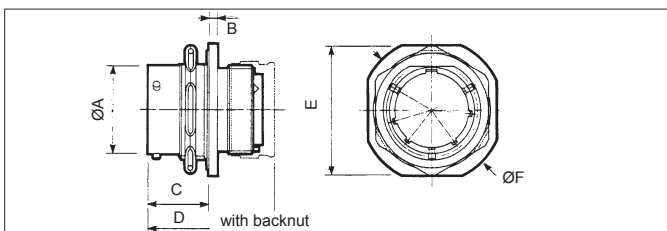

panel cut-out

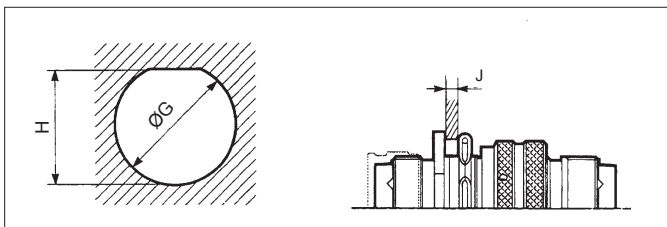

shells	A	B	C	D	E	F	G	H	J
	Max	Max	Max	Max	Max	Max			Max
8	12.03 .474	2.51 .099	17.55 .691	36.5 1.437	24.05 .947	27.2 1.071	14.53 .572	13.61 .536	4.75 .187
10	15.01 .591	2.51 .099	17.55 .691	36.5 1.437	27.2 1.071	30.4 1.197	17.7 .697	16.79 .661	4.75 .187
12	19.07 .751	2.51 .099	17.55 .691	36.5 1.437	32 1.260	35.15 1.384	22.73 .895	20.93 .824	4.75 .187
14	22.25 .876	2.51 .099	17.55 .691	36.5 1.437	35.15 1.384	38.35 1.510	25.65 1.010	24.08 .948	4.75 .187
16	25.42 1.001	2.51 .099	17.55 .691	36.5 1.437	38.35 1.510	41.5 1.634	28.83 1.135	27.23 1.072	4.75 .187
18	28.6 1.126	2.51 .099	17.55 .691	36.5 1.437	41.5 1.634	44.7 1.760	32 1.260	30.4 1.197	4.75 .187
20	31.77 1.251	3.3 .130	19.15 .754	38.1 1.500	46.25 1.821	49.45 1.947	35.18 1.385	33.58 1.322	6.35 .250
22	34.95 1.376	3.3 .130	19.15 .754	38.1 1.500	49.45 1.947	52.6 2.071	38.35 1.510	36.75 1.447	6.35 .250
24	38.12 1.501	3.3 .130	19.15 .754	38.1 1.500	52.6 2.071	55.8 2.197	41.53 1.635	39.93 1.572	5.55 .219

Square flange hermetic receptacle MS3440

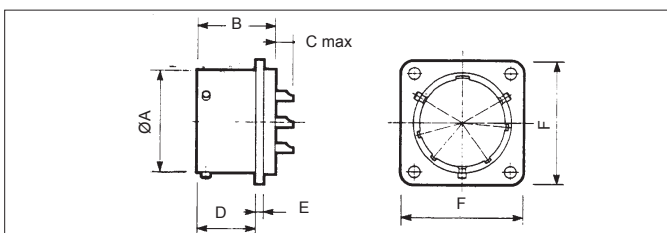

panel cut-out

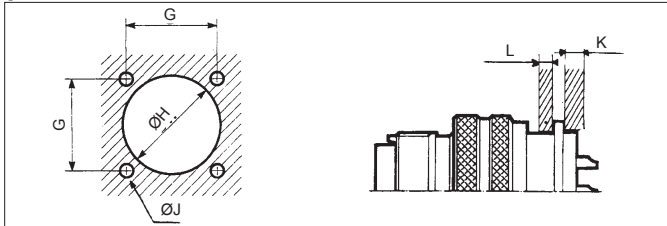

shells	A	B	C Max		D	E	F	G	H	J	K	L
	Max	Max	# 20	# 12 # 16	Max	Max	Max				Max	Max
8	12.05 .474	19.8 .780	4.5 .177	-	15.05 .593	1.95 .077	21 .827	15.1 .594	14.7 .612	3.15 .124	3.2 .126	3 .118
10	15 .591	19.8 .780	4.5 .177	-	15.05 .593	1.95 .077	24.2 .953	18.26 .719	17.5 .740	3.15 .124	3.2 .126	3 .118
12	19.05 .750	19.8 .780	4.5 .177	6.3 .248	15.05 .593	1.95 .077	26.55 1.045	20.62 .812	20.2 .872	3.15 .124	3.2 .126	3 .118
14	22.25 .876	19.8 .780	4.5 .177	6.3 .248	15.05 .593	1.95 .077	28.95 1.140	23.01 .906	23.4 .996	3.15 .124	3.2 .126	3 .118
16	25.4 1.000	19.8 .780	4.5 .177	6.3 .248	15.05 .593	1.95 .077	31.3 1.232	24.61 .969	26.6 1.120	3.15 .124	3.2 .126	3 .118
18	28.6 1.126	19.8 .780	4.5 .177	6.3 .248	15.05 .593	1.95 .077	33.7 1.327	26.97 1.062	28.8 1.246	3.15 .124	3.2 .126	3 .118
20	31.75 1.250	20.95 .825	4.5 .181	6.3 .248	16.6 .654	2.4 .094	36.9 1.453	29.36 1.156	32.1 1.370	3.15 .124	3.2 .126	5.4 .213
22	34.95 1.376	21.8 .858	3.7 .146	5.45 .219	16.6 .654	2.4 .094	40.1 1.579	31.75 1.250	35.3 1.496	3.15 .124	3.2 .126	5.4 .213
24	38.1 1.500	21.8 .858	3.7 .146	5.45 .219	16.6 .654	2.4 .094	43.25 1.703	34.92 1.375	38.4 1.622	3.3 .130	3.2 .126	5.4 .213



MIL-C 26482G Series II

Jam nut hermetic receptacle MS3449

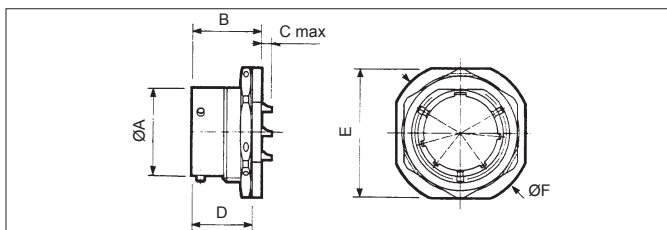

panel cut-out

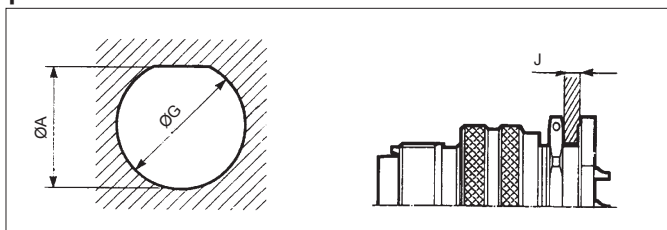

shells	A	B	C Max		D	E	F	G	H	J	
	Max	Max	# 20	# 12 # 16	Max	Max	Max			min	Max
8	12.05 .474	20.73 .816	3.4 .134	— —	17.91 .705	24.2 .953	27.34 1.076	14.6 .575	13.75 .541	1.57 .062	4.75 .187
10	15 .591	20.73 .816	3.4 .134	— —	17.91 .705	27.34 1.076	30.52 1.202	17.75 .699	16.95 .667	1.57 .062	4.75 .187
12	19.05 .750	20.73 .816	3.4 .134	5.2 .205	17.91 .705	32.12 1.265	35.29 1.389	22.5 .886	20.99 .846	1.57 .062	4.75 .187
14	22.25 .876	20.73 .816	3.4 .134	5.2 .205	17.91 .705	35.29 1.639	38.47 1.515	25.7 1.012	24.2 .953	1.57 .062	4.75 .187
16	25.4 1.000	20.73 .816	3.4 .134	5.2 .205	17.91 .705	38.47 1.639	41.64 1.639	28.85 1.136	27.35 1.077	1.57 .062	4.75 .187
18	28.6 1.126	20.73 .816	3.4 .134	5.2 .205	17.91 .705	41.64 1.639	44.82 1.765	32.05 1.262	30.55 1.203	1.57 .062	4.75 .187
20	31.75 1.250	23.08 .909	2.5 .098	4.3 .169	19.5 .768	46.39 1.826	49.59 1.952	35.2 1.386	33.7 1.327	1.57 .062	6.35 .250
22	34.95 1.376	23.08 .909	2.5 .098	4.3 .169	19.5 .768	49.59 1.952	52.74 2.076	38.4 1.512	36.9 1.453	1.57 .062	6.35 .250
24	38.1 1.500	23.83 .938	1.75 .069	3.55 .140	19.5 .768	52.74 2.076	55.92 2.202	41.55 1.636	40.05 1.577	1.57 .062	6.35 .250

Solder mounted hermetic receptacle MS3443

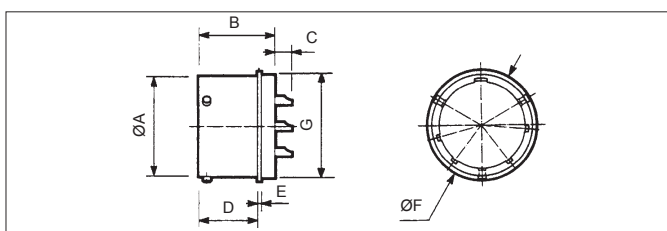

panel cut-out

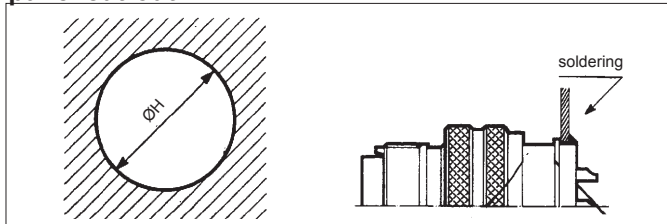

shells	A	B	C		D	E	F	G	H
	Max	Max	# 20	# 16 # 12	Max	Max	Max		
8	12.05 .474	19.5 .768	4.5 .177	— —	15.1 .594	1.1 .043	16.1 .634	14.27 .562	14.48 .570
10	15 .591	19.5 .768	4.5 —	— .594	15.1 .043	1.1 .760	19.3 .672	17.06 .680	17.27
12	19.05 .750	19.5 .768	4.5 .177	6.3 .248	15.1 .594	1.1 .043	21.65 .852	19.83 .781	20.04 .789
14	22.25 .876	19.5 .768	4.5 .177	6.3 .248	15.1 .594	1.1 .043	24.85 .978	23.01 .906	23.22 .914
16	25.4 1.000	19.5 .768	4.5 .177	6.3 .248	15.1 .594	1.1 .043	28 1.102	26.18 1.031	26.39 1.039
18	28.6 1.126	19.5 .768	4.5 .177	6.3 .248	15.1 .594	1.1 .043	31.15 1.226	29.36 1.156	29.57 1.164
20	31.75 1.250	21.1 .831	4.5 .177	6.3 .248	16.7 .657	1.1 .043	33.55 1.321	31.74 1.250	31.95 1.258
22	34.95 1.376	22 .866	3.7 .146	5.5 .217	16.7 .657	1.1 .043	36.75 1.447	34.92 1.375	35.13 1.383
24	38.1 1.500	22 .866	3.7 .146	5.5 .217	16.7 .657	1.1 .043	39.95 1.573	38.09 1.500	38.3 1.508

Reusable fixing plate

Two, three or four holes self locking fixing plates are available at SHTP. See page 759.

gaskets

shells	gaskets square flange receptacle MS3470 and MS3440 (ordered separately)	0-ring jam nut receptacle MS3474 and MS3449 (spare 0-rings)
	8	8525-1431
10	8525-1432	MS9068-018
12	8525-1433	MS9068-021
14	8525-1434	MS9068-023
16	8525-1435	MS9068-025
18	8525-1436	MS9068-027
20	8525-1437	MS9068-029
22	8525-1438	MS9068-030
24	8525-1439	MS9068-031



MIL-C 26482G Series II

Protective caps

basic series	852	28	R	10
cap type	28 - cap for plug 27 - cap for square flange receptacle 29 - cap for jam nut receptacle			
plating	W - olive green cadmium N - nickel R - black anodized			

Caps for receptacle

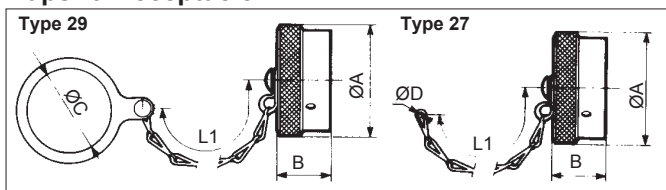

Caps for plug

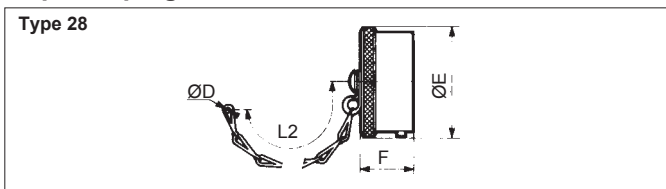

Dummy receptacle

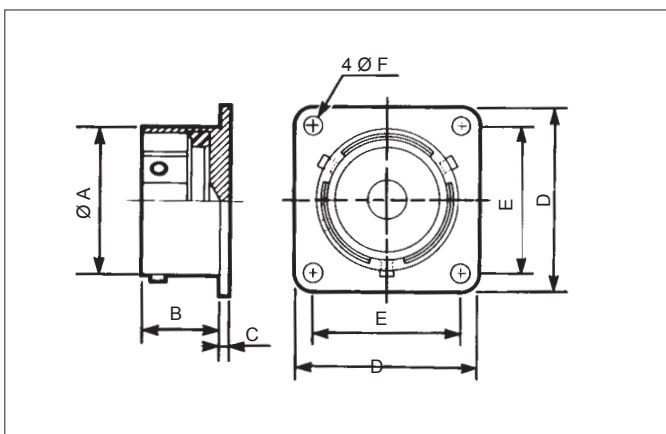

Light weight and special backshells

basic series	852	02	W	10
cap type	02 - straight cable clamp 03 - elbow cable clamp 32 - backshell with shield termination and heatshrink sleeving			
plating	W - olive green cadmium N - nickel R - black anodized			

Shells	A Max	B Max	C Max	D	E Max	F Max	L1	L2
8	19.748	14.25561	14.8583	3.5138	16.8661	15.591	843.307	843.307
10	21.8858	14.25561	18.709	3.5138	19.878	15.591	843.307	843.307
12	26.1	14.25561	22.7894	3.5138	23.9941	15.591	1003.937	1003.937
14	29.31154	14.25561	25.9102	3.5138	271.063	15.591	1003.937	1003.937
16	32.5128	15.591	291.142	3.5138	30.21189	15.591	1003.937	1003.937
18	35.3139	15.591	32.21268	3.5138	33.41315	15.591	1003.937	1003.937
20	38.81528	14.25561	35.41394	3.5138	36.51437	16.565	1164.567	1164.567
22	421.654	15.591	38.61520	3.5138	39.81567	16.565	1164.567	1164.567
24	45.11776	15.8622	41.71642	3.5138	42.91689	16.565	1164.567	1164.567

Shells	Part number		A Max	B Max	C	D Max	E	F
	olive green	nickel						
8	8526-0708	8526-07N08	12.03474	11.7461	1.35053	21.827	15.09594	3.1122
10	8526-0710	8526-07N10	15.01591	11.7461	1.35053	24.2953	18.26719	3.1122
12	8526-0712	8526-07N12	19.07751	11.7461	1.35053	26.551045	20.62812	3.1122
14	8526-0714	8526-07N14	22.25876	11.7461	1.35053	291.142	23.01906	3.1122
16	8526-0716	8526-07N16	25.421001	11.7461	1.35053	31.31232	24.61969	3.1122
18	8526-0718	8526-07N18	28.61126	11.7461	1.35053	33.71327	26.971062	3.1122
20	8526-0720	8526-07N20	31.771251	14.35565	2.15085	36.91453	29.361156	3.1122
22	8526-0722	8526-07N22	34.951376	14.35565	2.15085	401.575	31.751250	3.1122
24	8526-0724	8526-07N24	38.121501	15.2598	2.15085	43.31705	34.921375	3.75148



MIL-C 26482G Series II

Straight cable clamp type 02

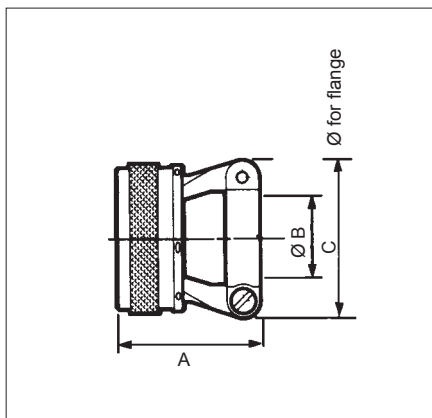

Elbow cable clamp type 03

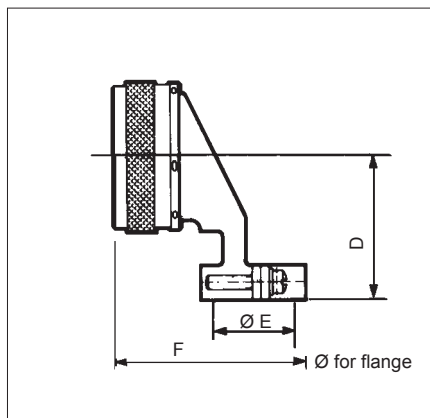

Backshell with shield termination and heatshrink sleeving type 32

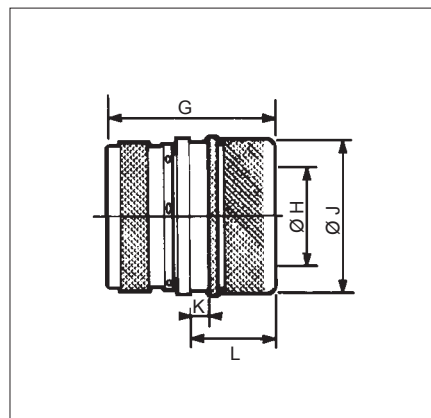

Shells	A Max	B		C Max	D Max	E		F Max	G Max	H Max	J Max	K Max	L Max
		mini	Max			mini	Max						
8	22.25 .876	4 .157	5.85 .230	19.1 .752	20 .787	4 .157	5.85 .230	25 .984	29 1.142	7.5 .295	18.2 .717	3.7 .146	15 .591
10	22.25 .876	6.85 .27	8.7 .343	20.3 .799	22.2 .874	6.85 .27	8.7 .343	27.9 1.098	29 1.142	9.7 .382	19.2 .756	3.7 .146	15 .591
12	22.25 .876	10.15 .400	12 .472	23.5 .925	24 .945	10.15 .400	12 .472	31.2 1.228	29 1.142	13 .512	24.2 .953	3.7 .146	15 .591
14	27.45 1.081	11.7 .461	16.75 .659	25.5 1.004	24.5 .965	11.7 .461	16.75 .659	32.8 1.291	29 1.142	15 .591	27.2 1.071	3.7 .146	15 .591
16	27.45 1.081	15.5 .610	20.55 .809	29.5 1.161	27 1.063	15.5 .610	20.55 .809	36.5 1.437	29 1.142	18.3 .720	30.2 1.189	3.7 .146	15 .591
18	27.45 1.081	17.5 .689	22.55 .888	32.3 1.272	28.6 1.126	17.5 .689	22.55 .888	38.5 1.516	29.3 1.154	21 .827	33.2 1.307	3.7 .146	15 .591
20	27.45 1.081	20.7 .815	25.75 1.014	36 1.417	30.1 1.185	20.7 .815	25.75 1.014	41.80 1.646	29.3 1.154	23.5 .925	36.3 1.429	3.7 .146	15 .591
22	27.45 1.081	23.9 .941	28.95 1.140	39 1.535	31.9 1.256	23.9 .941	28.95 1.140	45 1.772	29.3 1.154	26.5 1.043	39.5 1.555	3.7 .146	15 .591
24	27.45 1.081	27 1.063	32.05 1.262	42.7 1.681	33.4 1.315	27 1.063	32.05 1.262	48 1.890	29.3 1.154	30 1.181	42.6 1.677	3.7 .146	15 .591



MIL-C 26482G Series II

Male - Female Saver Ordering information

basic series	SN 1206- **- **- S* -* -* -*
shell size	08-10-12-14-16-18-20-22-24
contact layout	standard # 20 contact layout
contact type	Pin / Socket (socket on locking ring side)
plating	W - olive green N - black
shielding	B - with O - without
blocking system	B - heatshrink sleeve F - floating ring Q - without

Dimensions

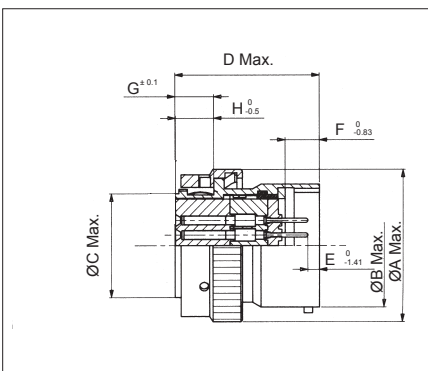

Shell size	Contact layouts	Polarization	A Max	B Max	C Max	D Max	E	F	G	H	I Max
8	3A, 33	N, W	19.03 .749	12.03 .474	9.09 .358	33.90 1.335	2.68 .106	8.38 .330	9.10 .358	9.06 .357	21.70 .854
10	6	N, W	21.83 .859	15.01 .591	12.34 .486	33.90 1.335	2.68 .106	8.38 .330	9.10 .358	9.06 .357	24.50 .965
12	10	N, W, X, Y, Z	26.13 1.029	19.07 .751	15.19 .598	33.90 1.335	2.68 .106	8.38 .330	9.10 .358	9.06 .357	28.80 1.134
14	19	N, W, X, Y	29.33 1.155	22.25 .876	18.36 .723	33.90 1.335	2.68 .106	8.38 .330	9.10 .358	9.06 .357	32.00 1.260
16	26	N, W, X, Y, Z	32.53 1.281	25.42 1.001	21.54 .848	33.90 1.335	2.68 .106	8.38 .330	9.10 .358	9.06 .357	35.20 1.386
18	32	N, W, X, Y, Z	35.33 1.391	28.60 1.126	24.08 .948	33.90 1.335	2.68 .106	8.38 .330	9.10 .358	9.06 .357	38.00 1.496
20	41	N, W, X, Y	38.83 1.529	31.77 1.251	27.25 1.073	35.50 1.398	4.28 .169	9.98 .393	10.70 .421	10.64 .419	41.50 1.634
22	55	N, W, X, Y, Z	42.03 1.655	34.95 1.376	30.43 1.198	35.50 1.398	4.28 .169	9.98 .393	10.70 .421	10.64 .419	44.70 1.760
24	61	N, W, X, Y, Z	45.13 1.777	38.12 1.501	33.60 1.323	35.50 1.398	4.28 .169	9.98 .393	10.70 .421	10.64 .419	47.80 1.882

MIL-C 26482G Series II



Tooling for basic series 8526 and 8525 extraction of unwired contacts

contacts size	part numbers
20	8522-56
16	8522-57
12	8522-58

filler plugs

contacts size	part numbers	colour
20	MS 27488-20	red
16	MS 27488-16	blue
12	MS 27488-12	yellow

These filler plugs are installed at the rear of unwired contacts to maintain connector sealing

Backshell tightening pliers, part number : 8498-03
Square jaws, part number : 8500-1015 (order 2 jaws)

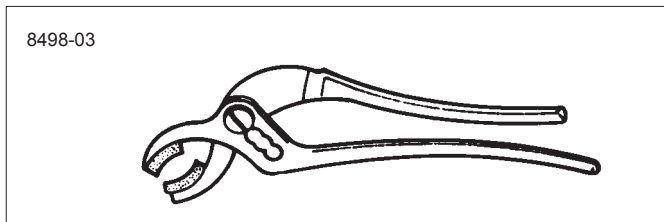

Strap backshell tightening spanner
par number : 8498-04

Square strap : 8498-103

crimping (contact size : 20, 16 and 12)

contacts size	wire sizes		part numbers	
	mm ²	AWG	crimping tools	locators
20	0.93*	18*	8365 (M22520/1-01) or 8476-01 (M22520/2-01)	8365-02 (M22520/1-02)
	0.60	20		or
	0.38	22		8476-02 (M22520/2-01)
	0.21	24		
16	1.91*	14*	8365 (M22520/1-01)	8365-02 (M22520/1-02)
	1.34	16		
	0.93	18		
	0.60	20		
12	3.18	12	8365 (M22520/1-01)	8365-02 (M22520/1-02)
	1.91	14		

insertion and extraction of wired contacts

disposable plastic tool
- colored tip. for insertion
- white tip. for extraction

contacts size	part numbers	colours
20	M 81969-14-11	red
16	M 81969-14-03	blue
12	M 81969-14-04	yellow

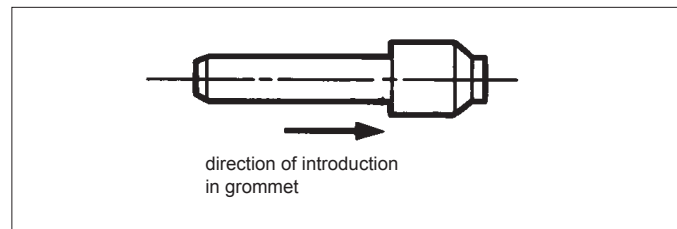
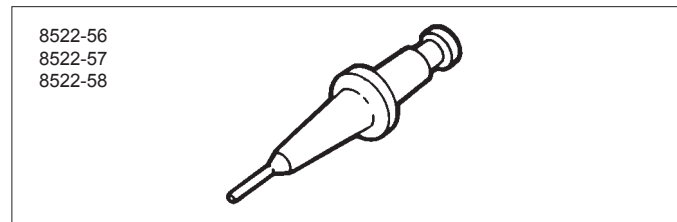
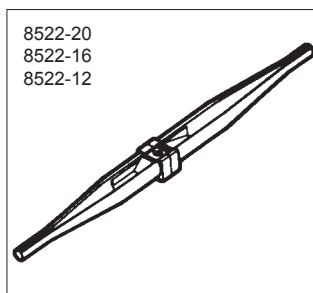

Tightening support, part number : 8500-30

