

Agilent AFBR-59R5LZ

Digital Diagnostic 2x7 SFF

850 nm 4.25/2.125/1.0625 GBd,

RoHS-Compliant Optical Transceiver

Data Sheet

Description

Agilent's AFBR-59R5LZ optical transceiver supports high-speed serial links over multimode optical fiber at signaling rates up to 4.25 GBd. Compliant with the Small Form Factor (SFF) Multi Source Agreement (MSA) 2x5/2x10 mechanical specifications for LC Duplex transceivers, ANSI Fibre Channel FC-PI and IEEE 802.3 for gigabit applications the part is electrically interoperable with 2x5 and 2x6 conformant devices. The AFBR-59R5LZ is dimensionally compliant with the SFF MSA form factor with the exception of two additional pins for communicating with the diagnostic interface.

As an enhancement to the conventional SFF 2x5 interface defined in the SFF MSA (Multi-Source Agreement), the AFBR-59R5LZ is compliant to SFF-8472 (digital diagnostic interface for optical

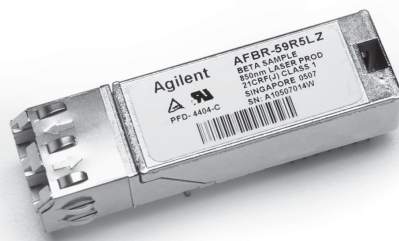

transceivers). Using the 2-wire serial interface defined in the SFF-8472 MSA, the AFBR-59R5LZ provides real time temperature, supply voltage, laser bias current, laser average output power and received average input power.

Features

- Fully RoHS Compliant
- Diagnostic Features Per SFF-8472 "Diagnostic Monitoring Interface for Optical Transceivers"
- Real time monitoring of:
 - Transmitted Optical Power
 - Received Optical Power
 - Laser Bias Current
 - Temperature
 - Supply Voltage
- Wide Temp and supply voltage operation (0°C to 70°C) (3.3 +/- 10%)

- Transceiver Specifications per SFF 2x5 Multi-Source Agreement and SFF-8472 (revision 9.3)

- 4.25 GBd Fibre Channel operation for FC-PI 400-M5-SN-I and 400-M6-SN-I
- 2.125 GBd Fibre Channel operation for FC-PI 200-M5-SN-1 and 200-M6-SN-I
- 1.0625 GBd Fibre Channel operation for FC-PI 100-M5-SN-I and 100-M6-SN-I

- Link Lengths at 4.25 Gbd:

- 150 m with 50 um MMF,
- 70 m with 62.5 um MMF

- Link Lengths at 2.125 Gbd

- 300m with 50um MMF
- 150m with 65.5um MMF

- Link Lengths at 1.0625 GBd:

- 500 m with 50 µm MMF,
- 300 m with 62.5 µm MMF

- LC Duplex optical connector interface conforming to ANSI TIA/EIA604-10 (FOCIS 10A)
- 850nm Vertical Cavity Surface Emitting Laser (VCSEL) Source Technology
- IEC 60825-1 Class 1/CDRH Class 1 laser eye safe
- Compatible with Gigabit Ethernet

Application

- Fibre Channel and iSCSI HBA Cards

Related Products

- AFBR-57R5APZ: 850 nm +3.3 V LC SFP for 4.25/2.125/1.0625 GBd Fibre Channel



This information is in addition to conventional SFP/GBIC base data. The digital diagnostic interface also adds the ability to disable the transmitter (TX_DISABLE), monitor for Transmitter Faults (TX_FAULT) and monitor for Receiver Signal Detect (Sig_Det). This 2x7 package also includes one dedicated 'hard' pin for TX_FAULT.

Digital Diagnostic Interface and Serial Identification

The 2-wire serial interface is based on ATMEL AT24C01A series EEPROM protocol and signaling detail. Conventional EEPROM memory, bytes 0-255 at memory address 0xA0, is organized in compliance with SFF-8074i. New digital diagnostic information, bytes 0-255 at memory address 0xA2, is compliant to SFF-8472. The new diagnostic information provides the opportunity for Predictive Failure Identification, Compliance Prediction, Fault Isolation and Component Monitoring.

Predictive Failure Identification

The predictive failure feature allows a host to identify potential link problems before system performance is impacted. Prior identification of link problems enables a host to service an application via "fail over" to a redundant link or replace a suspect device, maintaining system uptime in the process. For applications where ultra-high system uptime is required, a digital SFF provides a means to monitor two real-time laser metrics associated with observing laser degradation and predicting failure: average laser bias current (Tx_Bias) and average laser optical power (Tx_Power).

Compliance Prediction:

Compliance prediction is the ability to determine if an optical transceiver is operating within its operating and environmental requirements. AFBR-59R5LZ devices provide real-time access to transceiver internal supply voltage and

temperature, allowing a host to identify potential component compliance issues. Received optical power is also available to assess compliance of a cable plant and remote transmitter. When operating out of requirements, the link cannot guarantee error free transmission.

Fault Isolation

The fault isolation feature allows a host to quickly pinpoint the location of a link failure, minimizing system downtime. For optical links, the ability to identify a fault at a local device, remote device or cable plant is crucial to speeding service of an installation. AFBR-59R5LZ real-time monitors of Tx_Bias, Tx_Power, Vcc, Temp and Rx average power can be used to assess local transceiver current operating conditions. In addition, status flags Tx Disable and Rx Signal Detect are mirrored in memory and available via the two-wire serial interface.

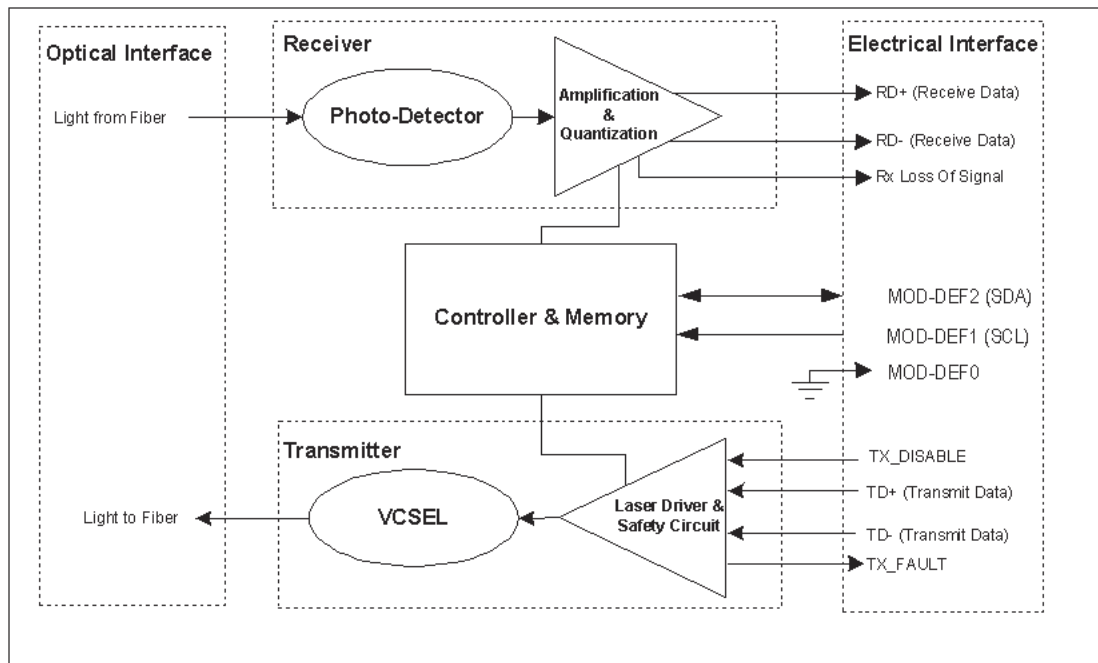

Figure 1. Transceiver Functional Diagram

Component Monitoring

The AFBR-59R5LZ real-time monitors of Tx_Bias, Tx_Power, Vcc, Temp and Rx Average Power may potentially be used as a debugging aid for system installation and design, and transceiver parametric evaluation for factory or field qualification. For example, temperature per module can be observed in high-density applications to facilitate thermal evaluation of blades and systems.

Transmitter Section

The transmitter section contains 850nm VCSEL (Vertical Cavity Surface Emitting Laser) light source, located at the optical interface which mates with the LC optical connector. The VCSEL is driven by a custom IC which uses the incoming differential (PECL compatible) high speed logic signal to modulate laser diode driver current. This Tx laser driver circuit regulates optical output power at a constant level provided the incoming data pattern is dc balanced (8B/10B code, for example).

Transmit Disable (Tx_Disable)

The AFBR-59R5LZ accepts a TTL transmit disable control signal input which shuts down the transmitter. A high signal implements this function while a low signal allows normal transceiver operation. In the event of a fault (e.g. eye safety circuit activated), cycling this control signal resets the module as depicted in Figure 5. An internal pull down resistor enables the laser if the line is not connected on the host board. Host systems should allow a 10ms interval between successive assertions of this control signal.

Tx_Disable can be asserted via the two-wire serial interface (address A2h, byte 110, bit 6) and monitored (address A2h, byte 110, bit 7).

The contents of A2h, byte 110 bit 6 are logic Or'd with the TX_DISABLE pin to control the transmit output.

Eye Safety Circuit

The AFBR-59R5LZ provides Class 1 (single fault tolerant) eye safety by design and has been tested for compliance with the requirements listed in Table 1. The eye safety circuit continuously monitors optical output power levels and will disable the transmitter upon detecting an unsafe condition beyond the scope of Class 1 certification. Such unsafe conditions can be due to inputs from the host board (Vcc fluctuation, unbalanced code) or a fault within the transceiver.

Receiver Section

The receiver section contains a PIN photodiode and custom transimpedance preamplifier, located at the optical interface which mates with the LC optical connector. The output is fed to a custom IC that provides post-amplification and quantization.

Signal Detect (Sig_Det)

The post-amplification IC also includes the transition detection circuitry which monitors the ac level of incoming optical signals and provides a TTL status signal to the host. An adequate optical input results in high signal detect output while a low signal detect output indicates an unusable optical input. The signal detect thresholds are set so that a low output indicates a definite optical fault has occurred. Signal Detect can be monitored via the two-wire serial (address A2h, byte 110, bit 1).

Functional Data I/O

The AFBR-59R5LZ interfaces with the host circuit board through fourteen I/O pins (2x7) identified by function in Table 2. These pins are sized for the use in boards between 0.062 in. and 0.100 in. thick. The board layout for this interface is depicted in Figure 7.

The AFBR-59R5LZ transmit and receive interfaces are PECL compatible. To simplify board requirements, transmitter bias resistors and ac coupling capacitors are incorporated into the transceiver module and so are not required on the host board. The Tx_Disable and Signal Detect lines require TTL lines on the host board if they are to be utilized. The transceiver will operate normally if these lines are not connected on the host board.

Figure 2 depicts the recommended interface circuit to link the AFBR-59R5LZ to the supporting physical layer ICs. Timing for MSA compliant control signals implemented in the transceiver are listed on Page 12 and diagramed in Figure 5.

PCB Assembly Process Compatibility

The AFBR-59R5LZ is compatible with industry standard wave solder and aqueous wash processes as detailed on Page 13. The transceiver is shipped with a process plug to keep out impinging liquids, but is not intended to be immersed. After assembly, the process plug should be kept in place as a dust plug when the transceiver is not in use.

Caution

There are no user serviceable parts nor maintenance requirements for the AFBR-59R5LZ. All mechanical adjustments are made at the factory before shipping. Tampering with, modifying, misusing or improperly handling the AFBR-59R5LZ will void the product warranty. It may also result in improper operation and possibly overstress the laser source. Performance degradation or device failure may result. Connection of the AFBR-59R5LZ to a light source not compliant to IEEE 802.3 or ANSI FC-PI specifications, operating above the maximum operating conditions or in a manner inconsistent with its design and function may result in exposure to hazardous light radiation and may constitute an act of modifying or manufacturing a laser product.

Persons performing such an act are required by law to re-certify and re-identify the laser product under the provisions of U.S. 21 CFR (Subchapter J) and the TUV.

Ordering Information

Please contact your local field sales engineer or one of Agilent Technologies franchised distributors for ordering information. For technical information, please visit Agilent Technologies' WEB page at www.agilent.com or contact Agilent Technologies Semiconductor Products Customer Response Center at 1-800-235-0312. For information related to SFF Committee documentation visit www.sffcommittee.org

Regulatory Compliance

The AFBR-59R5LZ complies with all applicable laws and regulations as detailed in Table 1. Certification level is dependent on the overall configuration of the host equipment. The transceiver performance is offered as a figure of merit to assist the designer.

Electrostatic Discharge (ESD)

The AFBR-59R5LZ is compatible with ESD levels found in typical manufacturing and operating environments as described in Table 1. In the normal handling and operation of optical transceivers, ESD is of concern in two circumstances.

The first case is during handling of the transceiver prior to soldering onto the host board. To protect the device, it's important to use normal ESD handling precautions. These include using grounded wrist straps, workbenches and floor mats wherever the transceiver is handled.

The second case to consider is static discharges to the exterior of the host equipment chassis after assembly. If the optical interface is exposed to the exterior of host equipment cabinet, the transceiver may be subject to system level ESD requirements.

Electromagnetic Interference (EMI)

Equipment incorporating gigabit transceivers is typically subject to regulation by the FCC in the

United States, TUV and CENELEC EN55022 (CISPR 22) in the European Union and VCCI in Japan. The AFBR-59R5LZ's compliance to these standards is detailed in Table 1. The metal housing and shielded design of the AFBR-59R5LZ minimize the EMI challenge facing the equipment designer.



Flammability

The AFBR-59R5LZ optical transceiver is made of metal and high strength, heat resistant, chemical resistant and UL 94V-0 flame retardant plastic.

EMI Immunity

Due to its shielded design, the EMI immunity of the AFBR-59R5LZ exceeds typical industry standards.

Table 1. Regulatory Compliance

Feature	Test Method	Performance
Electrostatic Discharge (ESD) to the Electrical Pins	MIL-STD-883C Method 3015.4	Class 1 (> 2000 Volts)
Electrostatic Discharge (ESD) to the Duplex LC Receptacle	Variation of IEC 61000-4-2	Typically withstands at least 15 kV without damage when the duplex LC connector receptacle is contacted by a Human Body Model probe. Fulfills Live Traffic ESD testing up to 8 kV with less than 1 errored second.
Electromagnetic Interference (EMI)	FCC Class B CENELEC EN55022 Class B (CISPR 22A) VCCI Class 1	System margins are dependent on customer board and chassis design.
Immunity	Variation of IEC 61000-4-3	Typically shows no measurable effect from a 10 V/m field swept from 10 MHz to 1 GHz applied to the transceiver without a chassis enclosure
Laser Eye Safety and Equipment Type Testing	US FDA CDRH AEL Class 1 US21 CFR, Subchapter J per Paragraphs 1002.10 and 1002.12. (IEC) EN60825-1: 1994 + A11+A2 (IEC) EN60825-2: 1994 + A1 (IEC) EN60950: 1992 + A1 + A2 + A3 + A4 + A11	CDRH certification #9720151-57 TUV file #72042669
 		
Component Recognition	Underwriters Laboratories and Canadian Standards Association Joint Component Recognition for Information Technology Equipment Including Electrical Business Equipment	UL File # E173874 Must comply with UL1950 or CUL 1950.
RoHS Compliance		Less than 1000ppm of cadmium, lead, mercury, hexavalent chromium, polybrominated biphenyls, and polybrominated biphenyl ethers

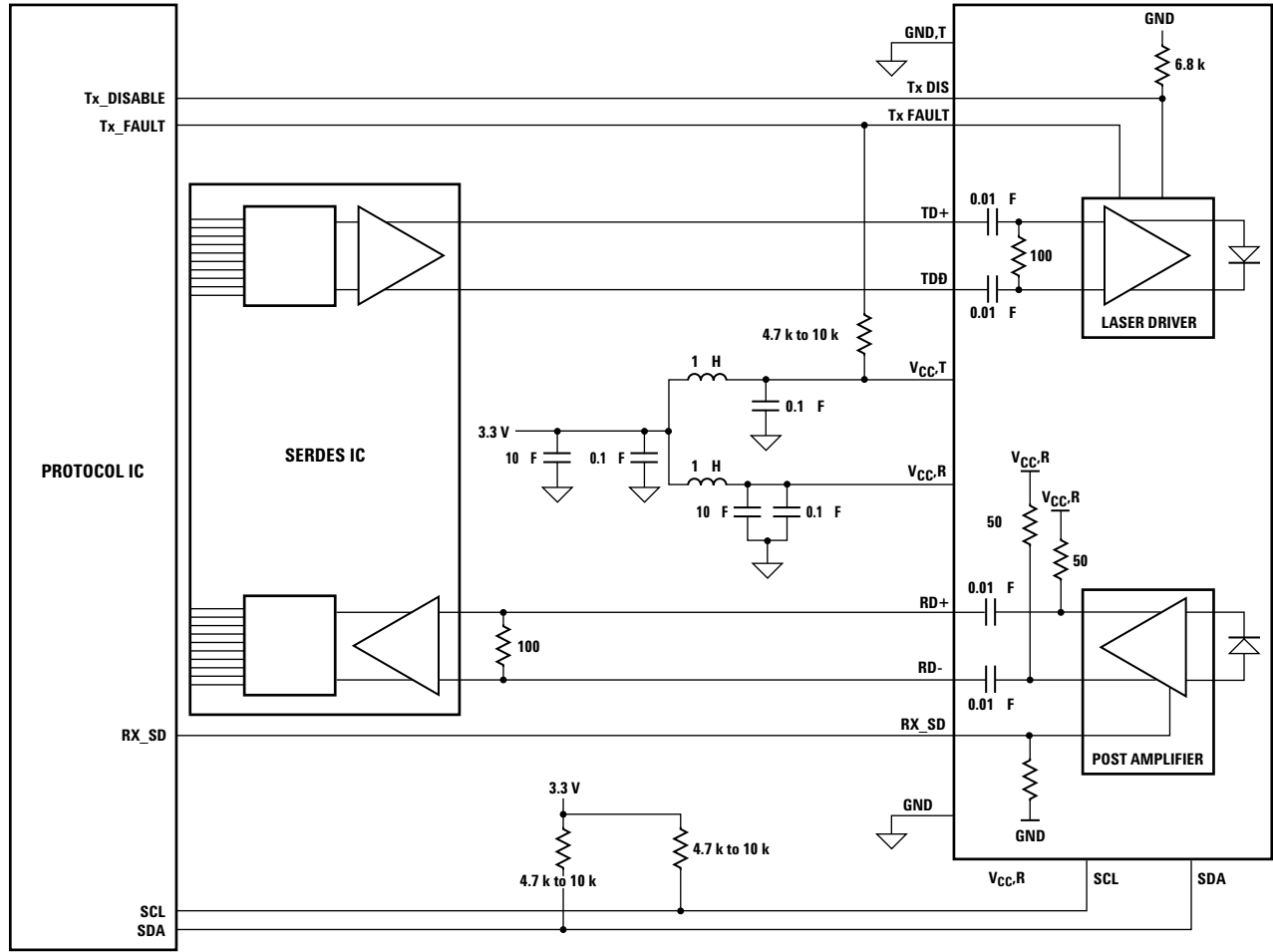
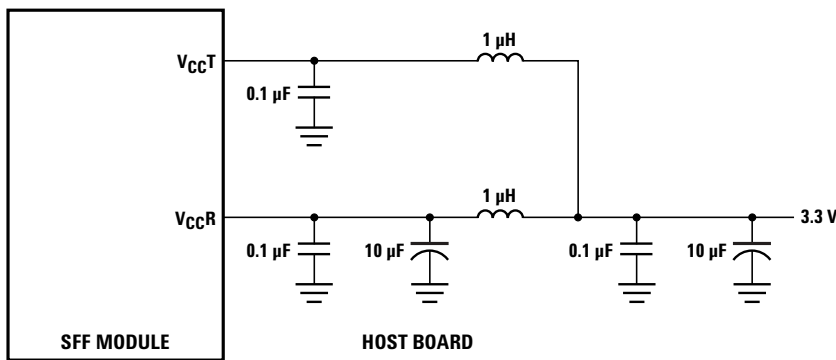

Figure 2. Typical Application Configuration



NOTE: INDUCTORS MUST HAVE LESS THAN 1 W SERIES RESISTANCE TO LIMIT VOLTAGE DROP TO THE SFF MODULE.

Figure 3. Recommended Power Supply Filter

Table 2. Pin Description

Pin	Name	Function/Description	Notes
1	V _{EE} R	Receiver Signal Ground	7
2	V _{CC} R	Receiver Power Supply: +3.3V	5
3	SD	TTL Signal Detect: Active High	3
4	RD-	Received Data Out Bar	4
5	RD+	Received Data Out	4
6	V _{CC} T	Transmitter Power Supply: +3.3V	5
7	V _{EE} T	Transmitter Signal Ground	7
8	TX_DISABLE	TTL Transmitter Disable: Active High, (Open = Enabled)	1
9	TD+	Transmitter Data In	6
10	TD-	Transmitter Data In Bar	6
A	SDA	Serial Interface Data I/O (Mod-def2)	2
B	SCL	Serial Interface Clock Input (Mod-def1)	2
C	NC		
D	TX_FAULT	Transmitter Fault Indication - High Indicates a fault condition	8

Notes:

- TX_DISABLE is an input that is used to shut down the transmitter optical output. It is pulled down with 6.8 kΩ internal to the transceiver.
 Low (0 – 0.8 V) or Open: Transmitter Enabled
 Between (0.8 V and 2.0 V): Undefined
 High (2.0 – V_{CC} max): Transmitter Disabled
 The TX_DISABLE pin state is logic Or'd with the contents of EEPROM address A2h, byte 110 bit 6 (soft disable control bit) to control the transmit output.
- The signals SDA and SCL designate the two wire serial interface pins. They must be pulled up with a 4.7 k – 10 kΩ resistor on the host board. SCL is the serial clock line of two wire serial interface. SDA is the serial data line of two wire serial interface
- Signal Detect is a normally high LVTTTL output. When high it indicates the received optical power is adequate for normal operation. When Low, it indicates the received optical power is insufficient to guarantee error free operation. In the low state, the output will be pulled to < 0.8 V.
- RD-/+ designate the differential receiver outputs. They are ac coupled 100 Ω differential lines which should be terminated with 100 Ω differential at the host SerDes input. AC coupling is done inside the transceiver and is not required on the host board. The voltage swing on these lines will be between 600 and 1600 mV differential (300 – 800 mV single ended) when properly terminated.
- V_{CC}R and V_{CC}T are the receiver and transmitter power supplies. They are defined at the transceiver pins.
- TD-/+ designate the differential transmitter inputs. They are ac coupled differential lines with 100 Ω differential termination inside the module. The ac coupling is done inside the module and is not required on the host board. The inputs will accept differential swings of 400 – 2400 mV (200 – 1200 mV single ended), though it is recommended that values between 500 and 1200 mV differential (250 – 600 mV single ended) be used for best EMI performance.
- Transmitter and Receiver Ground are common internally on the transceiver PCB. They are electrically connected to signal ground within the transceiver.
- TX_FAULT is an open collector/drain output, which must be pulled up with a 4.7k – 10kΩ resistor on the host board. When high, this output indicates a laser fault of some kind. Low indicates normal operation. In the low state, the output will be pulled to < 0.8V.

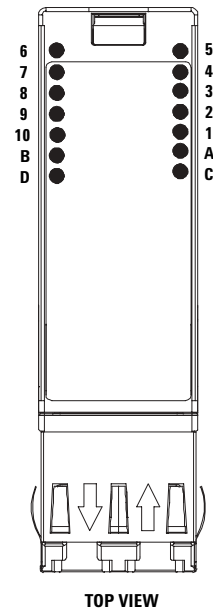

Figure 4. Module pin configuration.

Table 3. Absolute Maximum Ratings

Parameter	Symbol	Minimum	Maximum	Unit	Notes
Storage Temperature	T_s	-40	+100	°C	1, 2
Case Operating Temperature	T_c	-40	+100	°C	1, 2
Aqueous Wash Pressure			110	psi	
Maximum Wave or Flow Soldering Temperature	T_F		+260	°C	4
Relative Humidity, non condensing	RH	5	95	%	1
Supply Voltage	$V_{CCT, R}$	-0.5	3.8	V	1, 2, 3
Voltage to any pin		-0.5	3.8	V	
Low Speed Input Voltage	V_{IN}	-0.5	$V_{CC} + 0.5$	V	1

Table 4. Recommended Operating Conditions

Parameter	Symbol	Minimum	Maximum	Unit	Notes
Case Operating Temperature	T_c	-10	+70	°C	5, 6
Supply Voltage	$V_{CCT, R}$	2.97	3.63	V	6, 7
Data Rate		1.0625	4.25	Gb/s	6

Table 5. Transceiver Electrical Characteristics
($T_C = -10^\circ\text{C}$ to $+70^\circ\text{C}$, V_{CCT} , $V_{CCR} = 3.3\text{ V} \pm 10\%$)

Parameter	Symbol	Minimum	Maximum	Unit	Notes
AC Electrical Characteristics					
Power Supply Noise Rejection (Peak-to-Peak)	PSNR	100		mV	6
DC Electrical Characteristics					
Module Supply Current	I_{CC}		210	mA	TX + RX
Power Dissipation	P_{DISS}		765	mW	
Low Speed Outputs:					
Signal Detect [SD], SDA	V_{OH}	2.0	$V_{CCT, R} + 0.3$	V	
	V_{OL}		0.8	V	
Low Speed Inputs:					
Transmitter Disable [TX_DIS], SCL, SDA	V_{IH}	2.0	V_{CC}	V	7
	V_{IL}	0	0.8	V	

Notes:

1. Absolute Maximum Ratings are those values beyond which damage to the device may occur if these limits are exceeded for other than a short period of time. See Reliability Data Sheet for specific reliability performance.
2. Between Absolute Maximum Ratings and the Recommended Operating Conditions functional performance is not intended, device reliability is not implied, and damage to the device may occur over an extended period of time.
3. The module supply voltages, V_{CCT} and V_{CCR} must not differ by more than 0.5 V or damage to the device may occur.
4. Maximum wave or flow soldering temperature should not be applied for more than 10 seconds.
5. Recommended Operating Conditions are those values for which functional performance and device reliability is implied.
6. Filter per SFF specification is required on host board to remove 10 Hz to 4 MHz content.
7. SCL and SDA are to be pulled up externally with a 4.7 k – 10 kΩ resistor on the host board to 3.3 V.

Table 6. Transmitter and Receiver Electrical Characteristics(T_C = -10°C to +70°C, V_{CC}T, V_{CC}R = 3.3 V ± 10%)

Parameter	Symbol	Minimum	Maximum	Unit	Notes
High Speed Data Input: Transmitter Differential Input Voltage (TD +/-)	V _i	400	2400	mV	1
High Speed Data Output: Receiver Differential Output Voltage (RD +/-)	V _o	600	1600	mV	2
Receiver Contributed Total Jitter (4.25 Gb/s)	TJ		0.26	UI	4
			62	ps	
Receiver Contributed Total Jitter (2.125 Gb/s)	TJ		0.262	UI	4
			123	ps	
Receiver Contributed Total Jitter (1.0625 Gb/s)	TJ		0.218	UI	4
			205	ps	
Receiver Electrical Output Rise & Fall Times (20-80%)	tr, tf	50	150	ps	5

Notes:

1. Internally ac coupled and terminated (100 Ohm differential).
2. Internally ac coupled but requires an external load termination (100 Ohm differential).
3. Contributed DJ is measured on an oscilloscope in average mode with 50% threshold and K28.5 pattern
4. Contributed TJ is the sum of contributed RJ and contributed DJ. Contributed RJ is calculated for 1×10^{-12} BER by multiplying the RMS jitter (measured on a single rise or fall edge) from the oscilloscope by 14. Per FC-PI (Table 13 - MM jitter output, note 1), the actual contributed RJ is allowed to increase above its limit if the actual contributed DJ decreases below its limits, as long as the component output DJ and TJ remain within their specified FC-PI maximum limits with the worst case specified component jitter input.
5. 20%-80% electrical rise & fall times measured with a 500 MHz signal utilizing a 1010 data pattern.

Table 7. Transmitter Optical Characteristics
 (T_C = -10°C to +70°C, V_{CC}T, V_{CC}R = 3.3 V ± 10%)

Parameter	Symbol	Minimum	Maximum	Unit	Notes
Modulated Optical Output Power (OMA) (Peak-to-Peak) 4.25 Gb/s	OMA	247		μW	8
Modulated Optical Output Power (OMA) (Peak-to-Peak) 2.125 Gb/s	OMA	196		μW	3
Modulated Optical Output Power (OMA) (Peak-to-Peak) 1.0625 Gb/s	OMA	156		μW	4
Average Optical Output Power	P _{out}	-9.0		dBm	1, 2
Center Wavelength	λ _C	830	860	nm	
Spectral Width - rms	σ _{rms}		0.85	nm	
Optical Rise/Fall Time	t _r , t _f		90	ps	7
RIN ₁₂ (OMA)	RIN		-118	dB/Hz	
Transmitter Contributed Total Jitter (4.25 Gb/s)	TJ		0.25 60	UI ps	6
Transmitter Contributed Total Jitter (2.125 Gb/s)	TJ		0.254 120	UI ps	6
Transmitter Contributed Total Jitter (1.0625 Gb/s)	TJ		0.267 251	UI ps	6
P _{out} TX_DISABLE Asserted	P _{OFF}		-35	dBm	

Notes:

1. Max P_{out} is the lesser of Class 1 safety limits (CDRH and EN 60825) or receiver power max.
2. Into 50/125 μm (0.2 NA) and 62.5/125 μm (0.275 NA) multimode optical fiber.
3. An OMA of 196 is approximately equal to an average power of -9 dBm assuming an Extinction Ratio of 9 dB.
4. An OMA of 156 is approximately equal to an average power of -10 dBm assuming an Extinction Ratio of 9 dB.
5. Contributed DJ is measured on an oscilloscope in average mode with 50% threshold and K28.5 pattern.
6. Contributed TJ is the sum of contributed RJ and contributed DJ. Contributed RJ is calculated for 1×10⁻¹² BER by multiplying the RMS jitter (measured on a single rise or fall edge) from the oscilloscope by 14. Per FC-PI (Table 13 - MM jitter output, note 1), the actual contributed RJ is allowed to increase above its limit if the actual contributed DJ decreases below its limits, as long as the component output DJ and TJ remain within their specified FC-PI maximum limits with the worst case specified component jitter input.
7. Measured 20-80%.
8. An OMA of 247 μW is approximately equal to an average power of -8 dBm, avg assuming an Extinction Ratio of 9 dB.

Table 8. Receiver Optical Characteristics(T_C = -10°C to +70°C, V_{CC}T, V_{CC}R = 3.3 V ± 10%)

Parameter	Symbol	Minimum	Maximum	Unit	Notes
Input Optical Power [Overdrive]	P _{IN}		0	dBm, avg	
Input Optical Modulation Amplitude (p-p) 4.25 Gb/s	OMA	61		μW, OMA	6, 7
Input Optical Modulation Amplitude (p-p) 2.125 Gb/s	OMA	49		μW, OMA	1, 6
Input Optical Modulation Amplitude (p-p) 1.0625 Gb/s	OMA	31		μW, OMA	2, 6
Stressed receiver sensitivity (OMA) 4.25 Gb/s		138		μW, OMA	50/125 μm fiber, 8
Stressed receiver sensitivity (OMA) 4.25 Gb/s		148		μW, OMA	62.5/125 μm fiber, 8
Stressed receiver sensitivity (OMA) 2.125 Gb/s		96		μW, OMA	50/125 μm fiber, 3
Stressed receiver sensitivity (OMA) 2.125 Gb/s		109		μW, OMA	62.5/125 μm fiber, 3
Stressed receiver sensitivity (OMA) 1.0625 Gb/s		55		μW, OMA	50/125 μm fiber, 4
Stressed receiver sensitivity (OMA) 1.0625 Gb/s		67		μW, OMA	62.5/125 μm fiber, 4
Return Loss		12		dB	
Signal Detect - Deassert	P _D		27.5	uW, OMA	
Signal Detect - Deassert		-30	-17.5	dBm, avg	5
Signal Detect - Assert	P _A		31	uW, OMA	
Signal Detect - Assert			-17.0	dBm, avg	5
Loss of Signal Hysteresis	P _A - P _D	0.5		dB	

Notes:

- 50/125 μm. An OMA of 49 is approximately equal to an average power of -15 dBm with an Extinction Ratio of 9dB.
- 50/125 μm. An OMA of 31 is approximately equal to an average power of -17 dBm with an Extinction Ratio of 9 dB.
- 2.125 Gb/s stressed receiver vertical eye closure penalty (ISI) min is 1.26 dB for 50 μm fiber and 2.03 dB for 62.5 μm fiber. Stressed receiver DCD component min (at TX) is 40 ps.
- 1.0625 Gb/s stressed receiver vertical eye closure penalty (ISI) min is 0.96 dB for 50 μm fiber and 2.18 dB for 62.5 μm fiber. Stressed receiver DCD component min (at TX) is 80 ps.
- These average power values are specified with an Extinction Ratio of 9 dB. The signal detect circuitry responds to valid 8B/10B encoded peak to peak input optical power, not average power.
- Input Optical Modulation Amplitude (commonly known as sensitivity) requires a valid 8B/10B encoded input.
- 50/125μm. An OMA of 61 μW is approximately equal to an average power of -14 dBm with an Extinction Ratio of 9 dB.
- 4.25 Gb/s stressed receiver vertical eye closure penalty (ISI) min is 1.67 dB for 50 μm fiber and 2.14 dB for 62.5 μm fiber. Stressed receiver DCD component min (at TX) is 20 ps.

Table 9. Transceiver Soft Diagnostic Timing Characteristics $(T_C = -10^{\circ}\text{C to } +70^{\circ}\text{C}, V_{CCT}, V_{CCR} = 3.3\text{ V} \pm 10\%)$

Parameter	Symbol	Minimum	Typical	Maximum	Unit	Notes
Hardware TX_DISABLE Assert Time	t_off			10	μs	1
Hardware TX_DISABLE Negate Time	t_on			1	ms	2
Time to initialize, including reset of TX_FAULT	t_init			300	ms	3
Hardware TX_DISABLE to Reset	t_reset	10			μs	4
Hardware Signal_Detect Deassert Time	t_loss_on			100	μs	5
Hardware Signal_Detect Assert Time	t_loss_off			100	μs	6
Software TX_DISABLE Assert Time	t_off_soft			100	ms	7
Software TX_DISABLE Negate Time	t_on_soft			100	ms	8
Software Tx_FAULT Assert Time	t_fault_soft			100	ms	9
Software Signal_Detect DeAssert Time	t_loss_on_soft			100	ms	10
Software Signal_Detect Assert Time	t_loss_off_soft			100	ms	11
Analog parameter data ready	t_data			1000	ms	12
Serial bus hardware ready	t_serial			300	ms	13
Write Cycle Time	t_write			10	ms	14
Serial ID Clock Rate	f_serial_clock			400	kHz	

Notes:

1. Time from rising edge of TX_DISABLE to when the optical output falls below 10% of nominal.
2. Time from falling edge of TX_DISABLE to when the modulated optical output rises above 90% of nominal.
3. Time from power on or falling edge of Tx_Disable to when the modulated optical output rises above 90% of nominal.
4. Time TX_DISABLE must be held high to reset the laser fault shutdown circuitry.
5. Time from loss of optical signal to Signal Detect De-Assertion.
6. Time from valid optical signal to Signal Detect Assertion.
7. Time from two-wire interface assertion of TX_DISABLE (A2h, byte 110, bit 6) to when the optical output falls below 10% of nominal. Measured from falling clock edge after stop bit of write transaction.
8. Time from two-wire interface de-assertion of TX_DISABLE (A2h, byte 110, bit 6) to when the modulated optical output rises above 90% of nominal.
9. Time from fault to two-wire interface TX_FAULT (A2h, byte 110, bit 2) asserted.
10. Time for two-wire interface de-assertion of Signal Detect (A2h, byte 110, bit 1) from loss of optical signal.
11. Time for two-wire interface assertion of Signal Detect (A2h, byte 110, bit 1) from presence of valid optical signal.
12. From power on to data ready bit asserted (A2h, byte 110, bit 0). Data ready indicates analog monitoring circuitry is functional.
13. Time from power on until module is ready for data transmission over the serial bus (reads or writes over A0h and A2h).
14. Time from stop bit to completion of a 1-8 byte write command.

Table 10. PCB Assembly Process Compatibility

Parameter	Symbol	Minimum	Typical	Maximum	Unit	Notes
Hand Lead Soldering Temperature/Time	T_{SOLD}/t_{SOLD}			+ 260/10	°C/sec	
Wave Soldering and Aqueous Wash	T_{SOLD}/t_{SOLD}			+ 260/10	°C/sec	
Aqueous Wash Pressure				110	psi	

Table 11. Transceiver Digital Diagnostic Monitor (Real Time Sense) Characteristics(T_C = 10 °C to +70 °C, V_{CC}T, V_{CC}R = 3.3 V ± 10%)

Parameter	Symbol	Min	Units	Notes
Transceiver (Internal) Temperature Accuracy	T_{INT}	± 3.0	°C	Temperature is measured internal to the transceiver and does not reflect case temperature. Valid from = -10°C to +70 °C internal transceiver temperature.
Transceiver (Internal) Supply Voltage Accuracy	V_{INT}	± 0.1	V	Supply voltage is measured internal to the transceiver and can, with less accuracy, be correlated to voltage at the SFF Vcc pin. Valid over 3.3 V ± 10%.
Transmitter Laser DC Bias Current Accuracy	I_{BIAS}	± 10	%	I_{BIAS} is better than ± 10% of the nominal value.
Transmitted Optical Output Power Accuracy (AVG - average power)	P_T	± 3.0	dB	Coupled into 50/125 μm multimode fiber. Valid from 100 μW,avg to 500 μW, avg.
Received Optical Input Power Accuracy (Average power))	P_R	± 3.0	dB	Coupled from 50/125 μm multimode fiber. Valid from 31 μW,OMA to 500 μW,OMA.

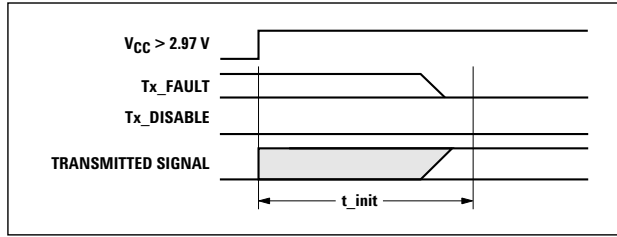

t-init: TX DISABLE NEGATED

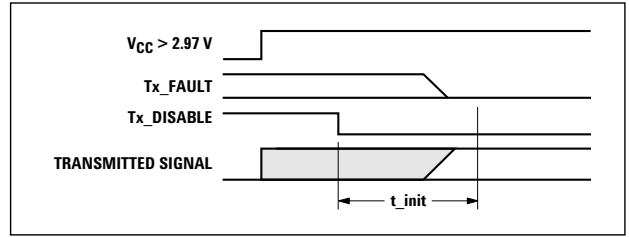

t-init: TX DISABLE ASSERTED

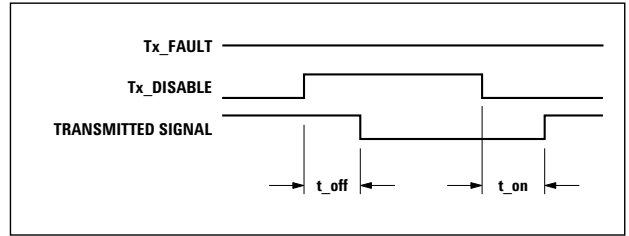

t-off & t-on: TX DISABLE ASSERTED THEN NEGATED

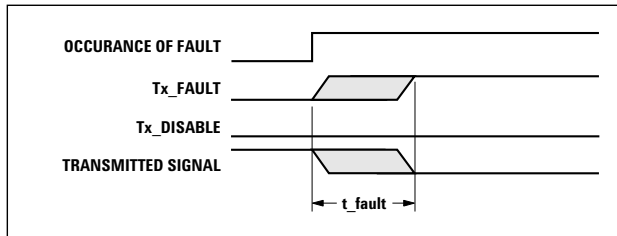

t-fault: TX FAULT ASSERTED, TX SIGNAL NOT RECOVERED

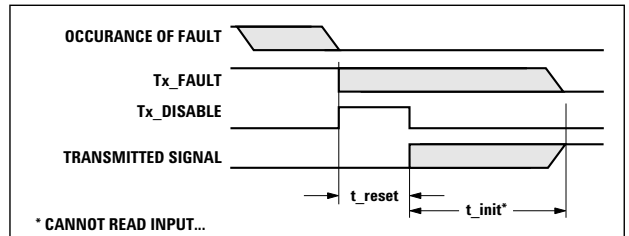

t-reset: TX DISABLE ASSERTED THEN NEGATED, TX SIGNAL RECOVERED

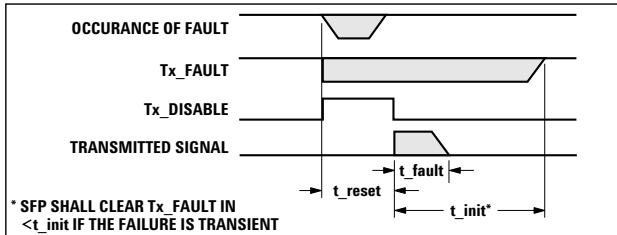

t-fault: TX DISABLE ASSERTED THEN NEGATED, TX SIGNAL NOT RECOVERED

* SFP SHALL CLEAR Tx_FAULT IN t_{init}^* IF THE FAILURE IS TRANSIENT

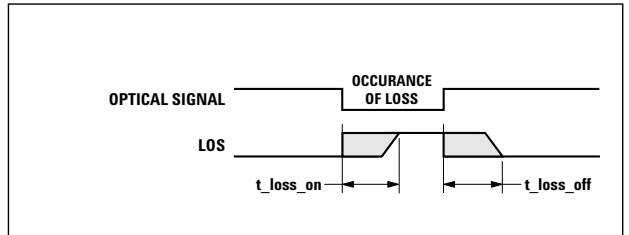

t-loss-on & t-loss-off

Figure 5. Transceiver Timing Diagrams (Tx_FAULT as reported by A2h Byte 110 Bit 2)

Table 12. EEPROM Serial ID Memory Contents – Conventional SFF Memory (Address A0h)

Byte # Decimal	Data Hex	Notes	Byte # Decimal	Data Hex	Notes
0	02	SFF physical device (soldered device)	37	00	Hex Byte of Vendor OUI ⁴
1	04	Serial ID function supported	38	30	Hex Byte of Vendor OUI ⁴
2	07	LC optical connector	39	D3	Hex Byte of Vendor OUI ⁴
3	00		40	41	"A" - Vendor Part Number ASCII character
4	00		41	46	"F" - Vendor Part Number ASCII character
5	00		42	42	"B" - Vendor Part Number ASCII character
6	00		43	52	"R" - Vendor Part Number ASCII character
7	20	Intermediate distance (per FC-PI)	44	2D	"-" - Vendor Part Number ASCII character
8	40	Shortwave laser w/o OFC (open fiber control)	45	35	"5" - Vendor Part Number ASCII character
9	0C	Multi-mode 50 μm and 62.5 μm optical media	46	39	"9" - Vendor Part Number ASCII character
10	15	100, 200 & 400 MBytes/sec FC-PI speed ¹	47	52	"R" - Vendor Part Number ASCII character
11	01	Compatible with 8B/10B encoded data	48	35	"5" - Vendor Part Number ASCII character
12	2B	4300 MBit/sec nominal bit rate (4.25 Gbit/s)	49	4C	"L" - Vendor Part Number ASCII character
13	00		50	5A	"Z" - Vendor Part Number ASCII character
14	00		51	20	" " - Vendor Part Number ASCII character
15	00		52	20	" " - Vendor Part Number ASCII character
16	0F	150m of 50/125 μm fiber @ 4.25GBit/sec ²	53	20	" " - Vendor Part Number ASCII character
17	07	70m of 62.5/125um fiber @ 4.25GBit/sec ³	54	20	" " - Vendor Part Number ASCII character
18	00		55	20	" " - Vendor Part Number ASCII character
19	00		56	20	" " - Vendor Part Number ASCII character
20	41	"A" - Vendor Name ASCII character	57	20	" " - Vendor Part Number ASCII character
21	47	"G" - Vendor Name ASCII character	58	20	" " - Vendor Part Number ASCII character
22	49	"I" - Vendor Name ASCII character	59	20	" " - Vendor Part Number ASCII character
23	4C	"L" - Vendor Name ASCII character	60	03	Hex Byte of Laser Wavelength ⁵
24	45	"E" - Vendor Name ASCII character	61	52	Hex Byte of Laser Wavelength ⁵
25	4E	"N" - Vendor Name ASCII character	62	00	
26	54	"T" - Vendor Name ASCII character	63		Checksum for Bytes 0-62 ⁶
27	20	" " - Vendor Name ASCII character	64	00	
28	20	" " - Vendor Name ASCII character	65	1C	Hardware SFF TX_DISABLE, TX_FAULT & Sig-Det
29	20	" " - Vendor Name ASCII character	66	00	
30	20	" " - Vendor Name ASCII character	67	00	
31	20	" " - Vendor Name ASCII character	68-83		Vendor Serial Number ASCII characters ⁷
32	20	" " - Vendor Name ASCII character	84-91		Vendor Date Code ASCII characters ⁸
33	20	" " - Vendor Name ASCII character	92	68	Digital Diagnostics, Internal Cal, Rx Avg Pwr
34	20	" " - Vendor Name ASCII character	93	F0	A/W, Soft TX_DISABLE, TX_FAULT & "RX_LOS" (signal detect)
35	20	" " - Vendor Name ASCII character	94	01	SFF-8472 Compliance to revision 9.3
36	00		95		Checksum for Bytes 64-94 ⁶
			96 - 255	00	

Notes:

1. FC-PI speed 100 MBytes/sec is a serial bit rate of 1.0625 GBit/sec. 200 MBytes/sec is a serial bit rate of 2.125 GBit/sec. 400 MBytes/sec is a serial bit rate of 4.25 GBit/sec.
2. Link distance with 50/125um cable at 1.0625 Gbit/sec is 500m. Link distance at 2.125 Gbit/sec is 300m.
3. Link distance with 62.5/125um cable at 1.0625 Gbit/sec is 300m. Link distance with 62.5/125um cable at 2.125 Gbit/sec is 150m.
4. The IEEE Organizationally Unique Identifier (OUI) assigned to Agilent Technologies is 00-30-D3 (3 bytes of hex).
5. Laser wavelength is represented in 16 unsigned bits. The hex representation of 850 (nm) is 0352.
6. Addresses 63 and 95 are checksums calculated (per SFF-8472 and SFF-8074i) and stored prior to product shipment.
7. Addresses 68-83 specify the AFBR-59R5LZ ASCII serial number and will vary on a per unit basis.
8. Addresses 84-91 specify the AFBR-59R5LZ ASCII date code and will vary on a per date code basis.

Table 13. EEPROM Serial ID Memory Contents – Enhanced Feature Set Memory (Address A2h)

Byte # Decimal	Notes	Byte # Decimal	Notes	Byte # Decimal	Notes
0	Temp H Alarm MSB ¹	26	Tx Pwr L Alarm MSB ⁴	104	Real Time Rx Pwr, MSB ⁵
1	Temp H Alarm LSB ¹	27	Tx Pwr L Alarm LSB ⁴	105	Real Time Rx Pwr, LSB ⁵
2	Temp L Alarm MSB ¹	28	Tx Pwr H Warning MSB ⁴	106	Reserved
3	Temp L Alarm LSB ¹	29	Tx Pwr H Warning LSB ⁴	107	Reserved
4	Temp H Warning MSB ¹	30	Tx Pwr L Warning MSB ⁴	108	Reserved
5	Temp H Warning LSB ¹	31	Tx Pwr L Warning LSB ⁴	109	Reserved
6	Temp L Warning MSB ¹	32	Rx Pwr H Alarm MSB ⁵	110	Status/Control - See Table 14
7	Temp L Warning LSB ¹	33	Rx Pwr H Alarm LSB ⁵	111	Reserved
8	V _{cc} H Alarm MSB ²	34	Rx Pwr L Alarm MSB ⁵	112	Flag Bits - See Table 15
9	V _{cc} H Alarm LSB ²	35	Rx Pwr L Alarm LSB ⁵	113	Flag Bits - See Table 15
10	V _{cc} L Alarm MSB ²	36	Rx Pwr H Warning MSB ⁵	114	Reserved
11	V _{cc} L Alarm LSB ²	37	Rx Pwr H Warning LSB ⁵	115	Reserved
12	V _{cc} H Warning MSB ²	38	Rx Pwr L Warning MSB ⁵	116	Flag Bits - See Table 15
13	V _{cc} H Warning LSB ²	39	Rx Pwr L Warning LSB ⁵	117	Flag Bits - See Table 15
14	V _{cc} L Warning MSB ²	40-55	Reserved	118	Reserved
15	V _{cc} L Warning LSB ²	56-94	External Calibration Constants ⁶	119	Reserved
16	Tx Bias H Alarm MSB ³	95	Checksum for Bytes 0-94 ⁷	120-127	Reserved
17	Tx Bias H Alarm LSB ³	96	Real Time Temperature MSB ¹	128-247	Customer Writeable ⁸
18	Tx Bias L Alarm MSB ³	97	Real Time Temperature LSB ¹	248-254	Vendor Specific
19	Tx Bias L Alarm LSB ³	98	Real Time V _{cc} MSB ²		
20	Tx Bias H Warning MSB ³	99	Real Time V _{cc} LSB ²		
21	Tx Bias H Warning LSB ³	100	Real Time Tx Bias MSB ³		
22	Tx Bias L Warning MSB ³	101	Real Time Tx Bias LSB ³		
23	Tx Bias L Warning LSB ³	102	Real Time Tx Power MSB ⁴		
24	Tx Pwr H Alarm MSB ⁴	103	Real Time Tx Power LSB ⁴		
25	Tx Pwr H Alarm LSB ⁴				

Notes:

1. Temperature (Temp) is decoded as a 16 bit signed twos complement integer in increments of 1/256 degrees C.
2. Supply Voltage (V_{cc}) is decoded as a 16 bit unsigned integer in increments of 100 uV.
3. Laser bias current (Tx Bias) is decoded as a 16 bit unsigned integer in increments of 2 uA.
4. Transmitted average optical power (Tx Pwr) is decoded as a 16 bit unsigned integer in increments of 0.1 uW.
5. Received average power (RX Pwr) is decoded as a 16 bit unsigned integer in increments of 0.1 uW.
6. Bytes 56-94 are not intended for use with AFBR-59R5LZ, but have been set to default values per SFF-8472.
7. Byte 95 is a checksum calculated (per SFF-8472) and stored prior to product shipment.
8. Bytes 128-247 are write enabled (customer writeable) .

Table 14. EEPROM Serial ID Memory Contents – Soft Commands (Address A2h, Byte 110)

Bit #	Status/Control Name	Description	Notes
7	TX_DISABLE State	Digital state of SFF TX_DISABLE Input Pin (1 = TX_DISABLE asserted)	1
6	Soft TX_DISABLE	Read/write bit for changing digital state of SFF TX_DISABLE function ¹	1, 2
5	reserved		
4	reserved		
3	reserved		
2	TX_FAULT State	Digital state of the laser fault function (1 = Laser Fault Detected)	1
1	Signal Detect State	Digital state of the SFF Sig_Det Output Pin (1 = Signal Detect asserted)	1
0	Data Ready (Bar)	Indicates transceiver is powered and real time sense data is ready. (0 = Ready)	1

Notes:

1. The response time for soft commands of the AFBR-59R5LZ is 100msec as specified by the MSA SFF-8472
2. Bit 6 is logic OR'd with the SFF TX_DISABLE input pin 8 either asserted will disable the SFF transmitter.
3. AFBR-59R5LZ meets the MSA SFF-8472 data ready timing of 1000 msec.

Table 15. EEPROM Serial ID Memory Contents – Alarms and Warnings (Address A2h, Bytes 112, 113, 116, 117)

Byte	Bit	Flag Bit Name	Description
112	7	Temp High Alarm	Set when transceiver internal temperature exceeds high alarm threshold.
	6	Temp Low Alarm	Set when transceiver internal temperature exceeds low alarm threshold.
	5	V _{cc} High Alarm	Set when transceiver internal supply voltage exceeds high alarm threshold.
	4	V _{cc} Low Alarm	Set when transceiver internal supply voltage exceeds low alarm threshold.
	3	Tx Bias High Alarm	Set when transceiver laser bias current exceeds high alarm threshold.
	2	Tx Bias Low Alarm	Set when transceiver laser bias current exceeds low alarm threshold.
	1	Tx Power High Alarm	Set when transmitted average optical power exceeds high alarm threshold.
	0	Tx Power Low Alarm	Set when transmitted average optical power exceeds low alarm threshold.
113	7	Rx Power High Alarm	Set when received average optical power exceeds high alarm threshold.
	6	Rx Power Low Alarm	Set when received average optical power exceeds low alarm threshold.
	0-5	reserved	
116	7	Temp High Warning	Set when transceiver internal temperature exceeds high warning threshold.
	6	Temp Low Warning	Set when transceiver internal temperature exceeds low warning threshold.
	5	V _{cc} High Warning	Set when transceiver internal supply voltage exceeds high warning threshold.
	4	V _{cc} Low Warning	Set when transceiver internal supply voltage exceeds low warning threshold.
	3	Tx Bias High Warning	Set when transceiver laser bias current exceeds high warning threshold.
	2	Tx Bias Low Warning	Set when transceiver laser bias current exceeds low warning threshold.
	1	Tx Power High Warning	Set when transmitted average optical power exceeds high warning threshold.
	0	Tx Power Low Warning	Set when transmitted average optical power exceeds low warning threshold.
117	7	Rx Power High Warning	Set when received average optical power exceeds high warning threshold.
	6	Rx Power Low Warning	Set when received average optical power exceeds low warning threshold.
	0-5	reserved	

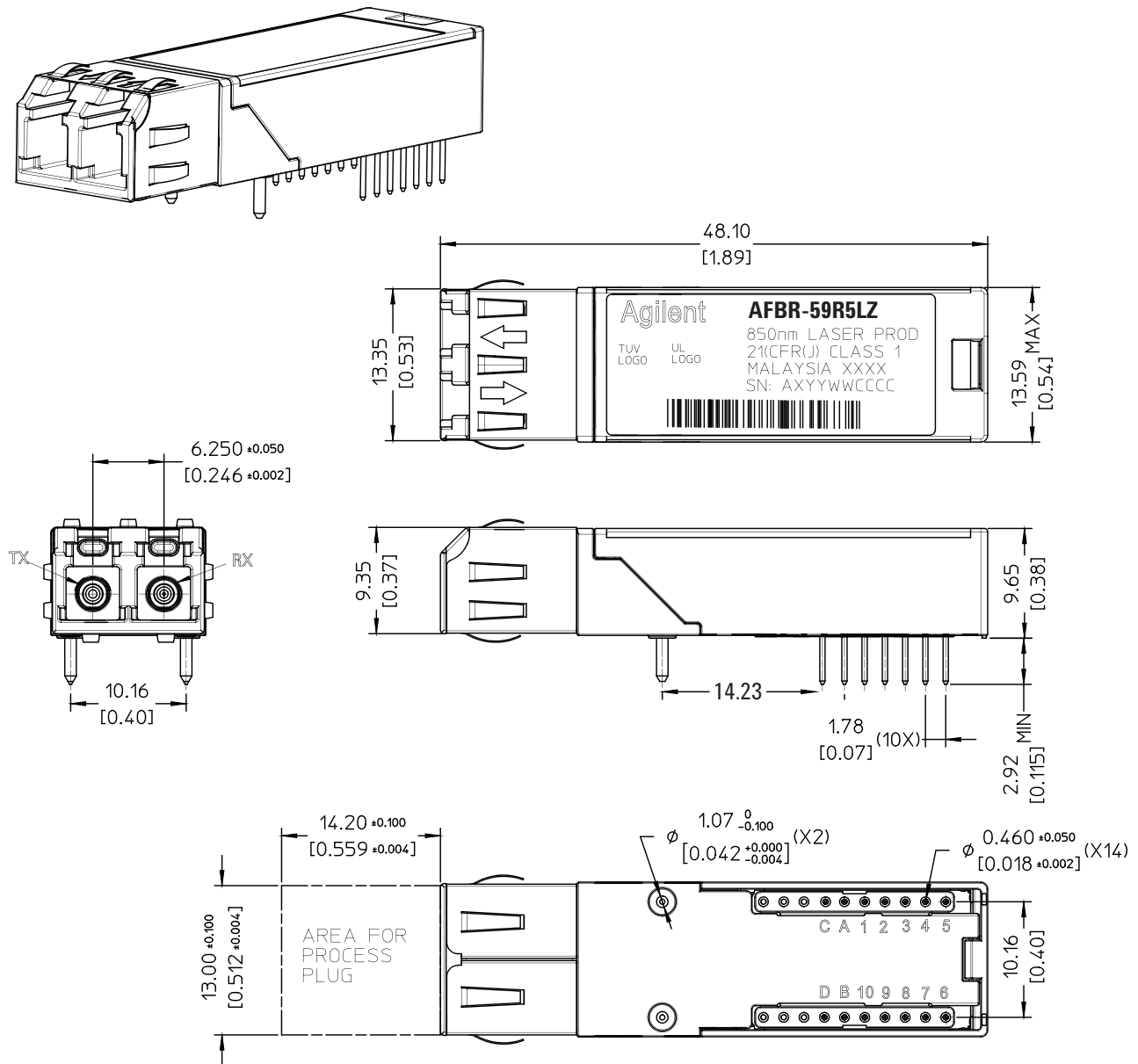

Figure 6. Mechanical Drawing

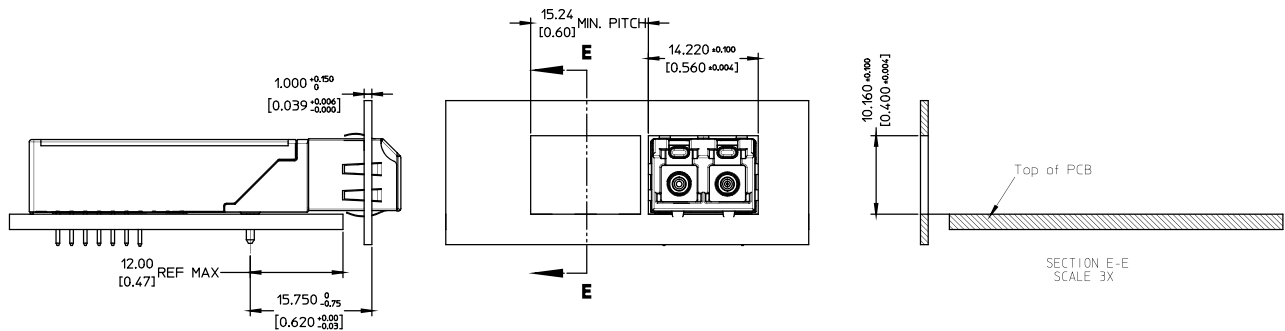
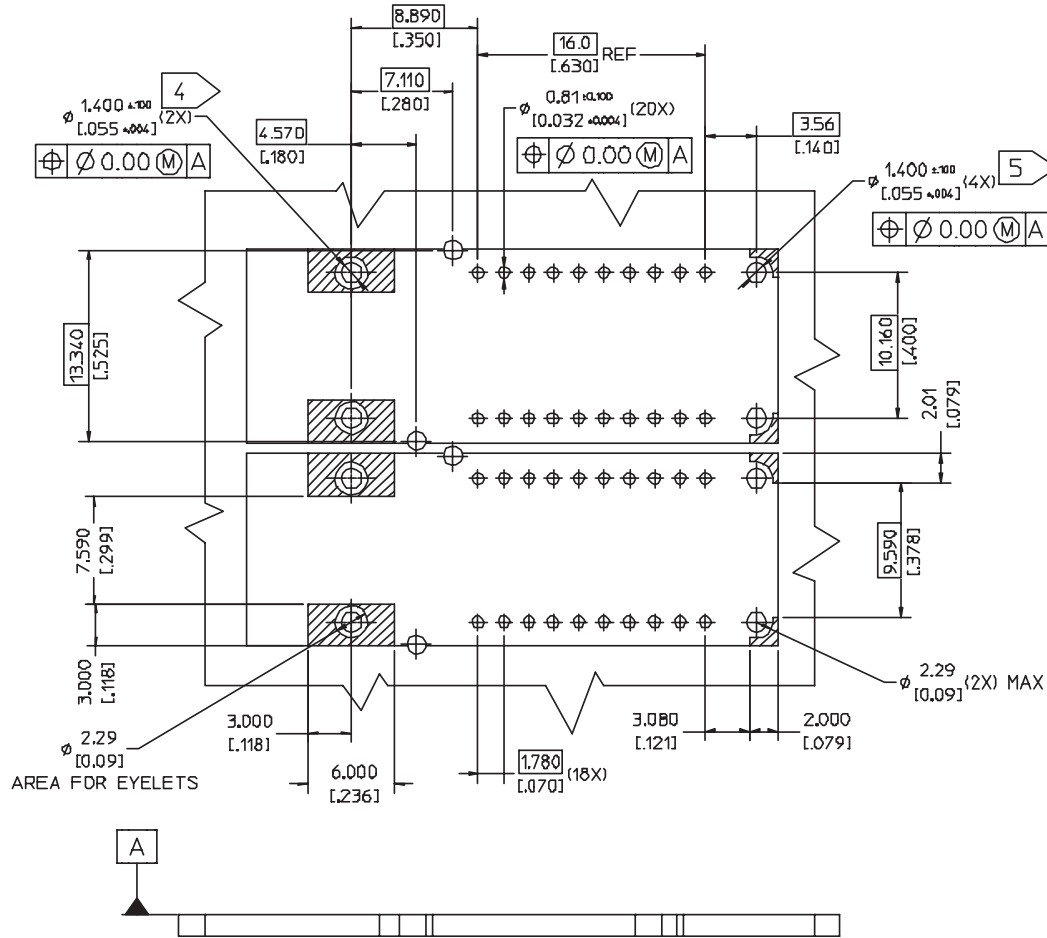

Figure 7. Assembly Drawing



1. THIS PAGE DESCRIBE THE RECOMMENDED CIRCUIT BOARD LAYOUT FOR THE SFF TRANSCEIVER.
2. THE HATCHED AREAS ARE KEEP-OUT AREAS RESERVED FOR HOUSING STANDOFFS. NO METAL TRACES OF GROUND CONNECTION IN KEEP-OUT AREA.
3. 20 PINS MODULE SHOWN. 10 PIN MODULE REQUIRES ONLY 16 PCB HOLES.

- 4 HOLES FOR MOUNTING STUDS MUST BE TIED TO CHASSIS GROUND.
- 5 HOLES FOR HOUSING LEADS MUST BE TIED TO SIGNAL GROUND

Figure 8. Board Layout

**[www.agilent.com/
semiconductors](http://www.agilent.com/semiconductors)**

For product information and a complete list of distributors, please go to our web site.

For technical assistance call:

Americas/Canada: +1 (800) 235-0312
or (916) 788-6763

Europe: +49 (0) 6441 92460

China: 10800 650 0017

Hong Kong: (65) 6756 2394

India, Australia, New Zealand: (65) 6755 1939

Japan: (+81 3) 3335-8152(Domestic/International), or 0120-61-1280(Domestic Only)

Korea: (65) 6755 1989

Singapore, Malaysia, Vietnam, Thailand, Philippines, Indonesia: (65) 6755 2044

Taiwan: (65) 6755 1843

Data subject to change.

Copyright © 2005 Agilent Technologies, Inc.

Obsoletes 5989-3018EN

September 29, 2005

5989-3624EN



Agilent Technologies