

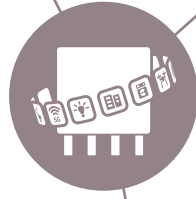

Datasheet.Live

Power and Sensing

Selection Guide 2019





Connectivity and linking the real to the digital world is no longer a dream – it is a lived reality. Future is something we create together to make life easier, safer, and greener.

连接真实世界和数字世界不再是一个梦想，而是活生生的现实。未来由我们共同创造，让生活更轻松、更安全、更环保。

Andreas Urschitz,
Division President of
Power Management & Multimarket
电力管理和多市场部门总裁

Dear Customer,

Today we communicate to everyone and everything. Interaction is no longer limited to human-to-human, but has been extended to human-to-machine and, with the latest innovations, even further to machine-to-machine communication.

As a leader in the semiconductor industry, Infineon is offering a wide product range of world-class power, sensor, and security technologies. Ultraprecise sensing solutions, such as advanced 3D ToF imagers, MEMS microphones or radar sensors, substitute human senses in IoT devices, enabling them to react to their surroundings. The next generations of GaN-based products open up a new paradigm of ultimate efficiency and reliability in power solutions that actuate sensing and computing functions at the very core of intelligent devices. Infineon's portfolio also integrates cooler, smaller and lighter audio amplifiers which enable customers to create better sounding products and enjoy exceptional audio performance of HMI-enabled speakers and other audio products.

These technologies together enable energy-efficient, secure, and seamless human-to-machine and machine-to-machine interaction and bridge the link between the real and the digital world. They also facilitate data storage in smart cities, industries, buildings, and homes, supporting the Internet of Intelligent Things.

The 2019 edition of the Power and Sensing Selection Guide offers great solutions for your future success; together, we will make life easier, safer, and greener.

尊敬的客户：

今天我们已步入互联时代，人与人、人与事的交互成为了现实。科技发展日新月异，本来仅局限于人与人之间的交互，已经扩展到人与机器之间，未来机器与机器的通信，也在最新技术的推动下成形。

作为半导体行业的领导者，英飞凌旗下备有一系列的世界级电源、传感器和安全技术。超精密的传感解决方案，如先进的3D ToF成像仪、MEMS麦克风或雷达传感器，在物联网设备中发挥人类感官的功能，对周围环境作出反应。下一代基于GaN的产品，是智能设备核心传感和计算功能的动力，为极高效而可靠的电源解决方案树立新标杆。英飞凌的产品组合还集成了更酷、更小、更轻的音频放大器，使客户能够创造更好的音响产品，并享受配备HMI的扬声器和其他音频产品的卓越音响表现。

上述技术结合应用，实现高效、安全、无缝的人机交互和机器对机器的交互，给现实世界和数字世界之间架起了桥梁。它们还支持智能物联网，促成智能城市、工业、建筑和家居的数据存储。

2019版的电力和传感选择指南的出色解决方案，为您指出未来成功之道；让我们共同努力，使生活变得更轻松、更安全、更环保。

Andreas Urschitz,
Division President of
Power Management & Multimarket
电力管理和多市场部门总裁

Contents

Applications	6	20-300 V MOSFETs	66
Battery powered applications	6		
E-mobility	8	500-950 V MOSFETs	96
Audio solutions	12		
DC-DC enterprise power solution for data processing	16	Wide bandgap semiconductors	122
Industrial welding	20		
LED lighting	22	Discrete IGBTs	144
Major home appliances	24		
Air conditioning	24	Power ICs	160
Induction cooking	25		
Multicopter	26	Gate driver ICs	224
Smart home	28		
Enabling secured communication for IoT	30	Motor control ICs	252
Robotics	31		
SMPS	34	Microcontrollers	254
Laptop adapter	34		
Mobile charger	36	Sensors	272
PC power supply	37		
TV power supply	38	Packages	302
Embedded power supply	41		
Server power supply	42		
Telecom power supply	44		
DC EV charging	46		
Uninterruptible power supply	50		
Solar	55		
Wireless charging	60		



From product thinking to system understanding

Infineon enables efficient generation, transmission and conversion of electrical energy



We make life easier, safer and greener – with technology that achieves more, consumes less and is accessible to everyone.

www.infineon.com/power

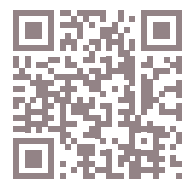

Applications
20-300 V MOSFETs
500-950 V MOSFETs
WBG semiconductors
Discrete IGBTs
Power ICs
Gate driver ICs
Motor control ICs
Microcontrollers
XENSIV™ sensors
Packages



Battery powered applications

Highest performance in motor control

We live in a mobile world filled with electrical devices - consumer-grade robots, light electric vehicles, multicopters and other end products driven by highly efficient electric motors. As these products evolve and improve, there is an increasing need for designers and engineers to find solutions that are more efficient, smaller, and less costly than ever before.

Based on the industry-leading technology, the highest quality, and manufacturing expertise, Infineon provides a variety of innovative power semiconductors addressing a broad range of battery powered motor control applications, such as power tools, forklifts, all kinds of light electric vehicles including e-skateboards, e-scooters, pedelecs, low speed cars, and many others. Through an excellent selection of devices for power management, consumption and voltage regulation – such as power MOSFETs (e.g. CoolMOS™, OptiMOS™, and HEXFET™/StrongIRFET™), XMC™ microcontrollers, EiceDRIVER™ gate drivers and more, Infineon offers all components that are needed for the compact, cost-effective designs of today, and for the innovative designs of tomorrow.

Consumer robotics	Home and professional applications	Light electric vehicles
Consumer multicopters, vacuum robots, RC toys, service, household, and other consumer robots	Power tools, gardening tools, commercial multicopters, cordless home appliance, cordless vacuum cleaners, and healthcare equipment	eScooter, eBike, electric wheelchair, electric forklift, low speed electric vehicles (LSEV), electric motorcycle, and other battery vehicles

Key enabling products for battery powered applications

	Consumer robotics	Home and professional applications	Light electric vehicles
MOSFETs	HEXFET™/StrongIRFET™ 20-300 V		
	OptiMOS™ 25-100 V		OptiMOS™ 80-300 V
	CoolMOS™ P7 superjunction (SJ) MOSFET*		
Gate driver ICs	EiceDRIVER™		
	200 V and 600 V gate driver ICs		
IPM	CIPOS™ Nano		
Microcontrollers	XMC1100	XMC1300/XMC1400	
	XMC1000/XMC4000	XMC4500/XMC4400	
	iMOTION™ and embedded power ICs		
Microcontroller and driver supply	Linear voltage and DC-DC switching regulators		
CAN transceivers	IFX1050, IFX1051		
Magnetic sensors	Hall and xMR sensors		
Authentication	OPTIGA™ Trust B/X, OPTIGA™ TPM	OPTIGA™ Trust B	

To shorten customer development time and cost, we offer a complete portfolio of low voltage motor control application kits:

XMC1000 motor control application kit	XMC4000 motor control application kit	iMOTION™ modular application design kit (MADK)	40 V Medium Can ME/MF DirectFET™ 3-phase BLDC motor drive demo board (DEMO-PTOOL-300W-M)

www.infineon.com/motorcontrol

* If the necessary package/ $R_{DS(on)}$ combination is not available in the new CoolMOS™ P7 series yet, the previous CoolMOS™ CE and P6 series are the preferred series

Typical battery powered three-phase system – a one-stop-shop for battery powered drives

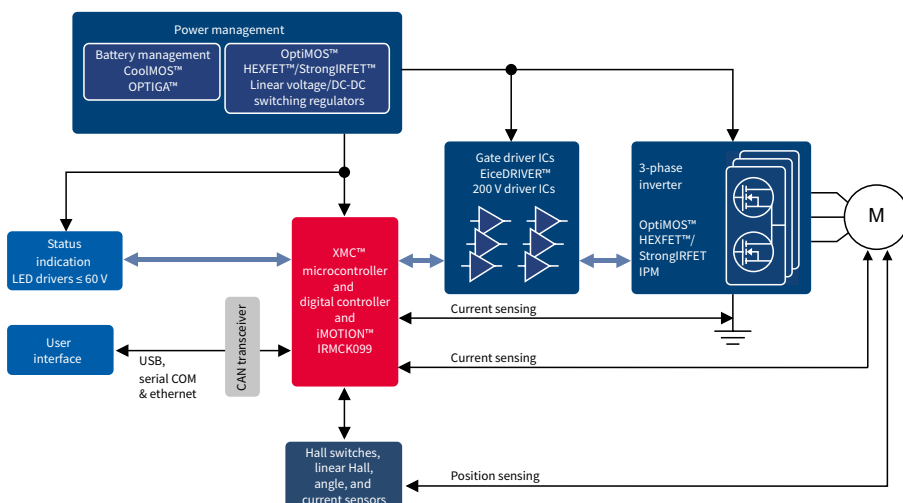

A complete set of components that ensure system-cost competitiveness and high performance solution

Infineon product offering	Consumer robotics	Home and professional applications	Light electric vehicles
Supply voltage	12-48 V	10.8-56 V	24-144 V
OptiMOS™ and HEXFET™/StrongIRFET™ power MOSFETs	Voltage	25-200 V	20-100 V
	Package	SuperS08, PQFN 3x3, DirectFET™ S/M/L-Can, TOLL, TO-220, DPAK, D ² PAK	SuperS08, PQFN 3x3, DirectFET™ S/M/L-Can, TOLL, TO-220, TO-247, DPAK, D ² PAK, D ² PAK 7-pin
CoolMOS™ P7 SJ MOSFET*	Voltage	600-800 V	600-700 V
Gate driver ICs	1EDN, 2EDN, 1EDN7550, 2EDL811x, 6ED003L02-F2, 6ED003L06-F2, 6EDL04N-02PR, 6EDL04N06PT, 2EDL05N06PF, IRS2005S, IRS2005M, IRS2007S, IRS2008S, IRS2011S Integrated gate driver ICs: IFX9201/2, NovalithIC™ BTN8982, Trilith IC BTM7752	1EDN/2EDN/6EDL04N02PR, 6ED003L02-F2, 2EDL05N06PF, 2ED2304S06F, IRS2005S/M, IRS2007S, IRS2008S, IRS2301, IRS21867, IRS2304 Integrated: IFX9201SG/ BTN8982	1EDN/2EDN/ 2EDL/ 6EDL04N02PR, 6ED003L02-F2, 2EDL05N06PF, 2ED2304S06F, IRS2005S/M, IRS2007S, IRS2008S, IRS2301, IRS21867, IRS2304
IPM – CIPOS™ Nano	IRSM836-0x4MA (x=2,4,8), IRSM808-204MH	IRSM005-800MH, IRSM005-301MH	
Authentication IC, security	OPTIGA™ Trust B/X, OPTIGA™ TPM	OPTIGA™ Trust B	OPTIGA™ Trust B
XMC™ microcontrollers iMotion™ ePower	XMC1100 XMC1000/XMC4000 iMOTION™: IRMCK099M ePower: TLE987X (BLDC), TLE986X (BDC)	XMC1300 XMC4400/XMC4500 iMOTION™: IRMCK099M ePower: TLE987X (BLDC)	XMC1300 XMC 4400/XMC4500
Microcontroller and driver supply: linear voltage and DCDC switching regulators	IFX1763/IFX54441/IFX54211/IFX30081/IFX90121/IFX91041		
CAN transceivers	IFX1050, IFX1051		
Sensors	Hall switches (TLE 496X), Angle sensor (TLI5012B, TLE5501), 3D magnetic sensor (TLV493D), Current sensor (TLI4970)	Hall switches (TLE496X), Angle sensor (TLI5012B), 3D magnetic sensor (TLV493D)	Hall switches (TLE496X), Angle sensor (TLI5012B), 3D magnetic sensor (TLV493D)

Why to choose Infineon as your partner for innovation in battery powered applications

Infineon product offering	Customer benefits
Complete solutions – broad portfolio	<ul style="list-style-type: none"> Whatever design specification, Infineon has the answer in the comprehensive portfolio of products and solutions which you can easily tailor to your needs Infineon offers solutions for power supplies, chargers, motor drives and sensors
Extended battery lifetime and product life spans	<ul style="list-style-type: none"> BiC MOSFETs e.g. OptiMOS™ and HEXFET™/StrongIRFET™ extend battery lifetime and reduce chances for control failure High reliability of Infineon components results in prolonged product lifespans
Productive capability	<ul style="list-style-type: none"> Offering LV FETs with SMD packaging improves the productive capability by automatic production, improves reliability and reduces assembly cost
Overall system size and cost reduction	<ul style="list-style-type: none"> With Infineon's components you can reduce of overall system size and cost due to components occupying smallest area and featuring compact design, both of which are required for highest power density and BOM savings thanks to lowest R_{DS(on)}
Security, quality and safety	<ul style="list-style-type: none"> Trustworthy hardware-based security As a security market leader with a proven track record and outstanding partner network for embedded security, Infineon provides highest quality standards and a safety certified development process
Authentication	<ul style="list-style-type: none"> OPTIGA™ Trust enables authentication of components connected to the system (e.g., battery pack recognition to avoid second party batteries etc.)
Fast time-to-market	<ul style="list-style-type: none"> Faster time-to-market is enabled by providing evaluation and demo boards for fast prototyping, and simulations, documentation, and system support that reduce development time and cost

www.infineon.com/motorcontrol

* If the necessary package/R_{DS(on)} combination is not available in the new CoolMOS™ P7 series yet, the previous CoolMOS™ CE and P6 series are the preferred series



E-mobility

Best solutions for battery chargers, wireless charging and battery management

To recharge the battery of an electric or hybrid car, a charger is needed. Chargers can be implemented onboard or off-board the vehicle. Electric energy is transferred to the vehicle by wire or by wireless methods like resonant inductive power transfer. Power units onboard the vehicle require automotive-grade components, while the wider product selection of industrial-grade components can be used for off-board units.

Onboard chargers

In cars with onboard chargers the batteries can be recharged from any standard AC power outlet, which provides maximum power of 6.6 kW best case (single-phase 230 V/32 A). This standard charging at low power takes several hours (overnight). Battery charging via the power grid requires a flexible power converter topology to handle different voltage and power ratings wherever the car may go to, and onboard chargers need to be as efficient and small as possible to stay cool at the lowest possible weight.

Off-board chargers

In off-board chargers, the power conversion from AC grid voltage to DC battery voltage is done outside the car and the resulting DC power is transmitted by wire to the DC-charging socket in an electric vehicle. Ultrafast chargers with power ratings at 50 kW and more have been designed in this way. As the power converter is off-board, automotive grade qualification is not required for the respective electronic components. Apart from fast and ultrafast chargers, there may be a market for off-board chargers in the power range up to 10 kW, for example to charge small and economic electric vehicles (LEVs). Also in case of the off-board chargers, selecting the right topology to enable maximum conversion efficiency is an important design criterion.

AC-DC battery chargers: functional blocks

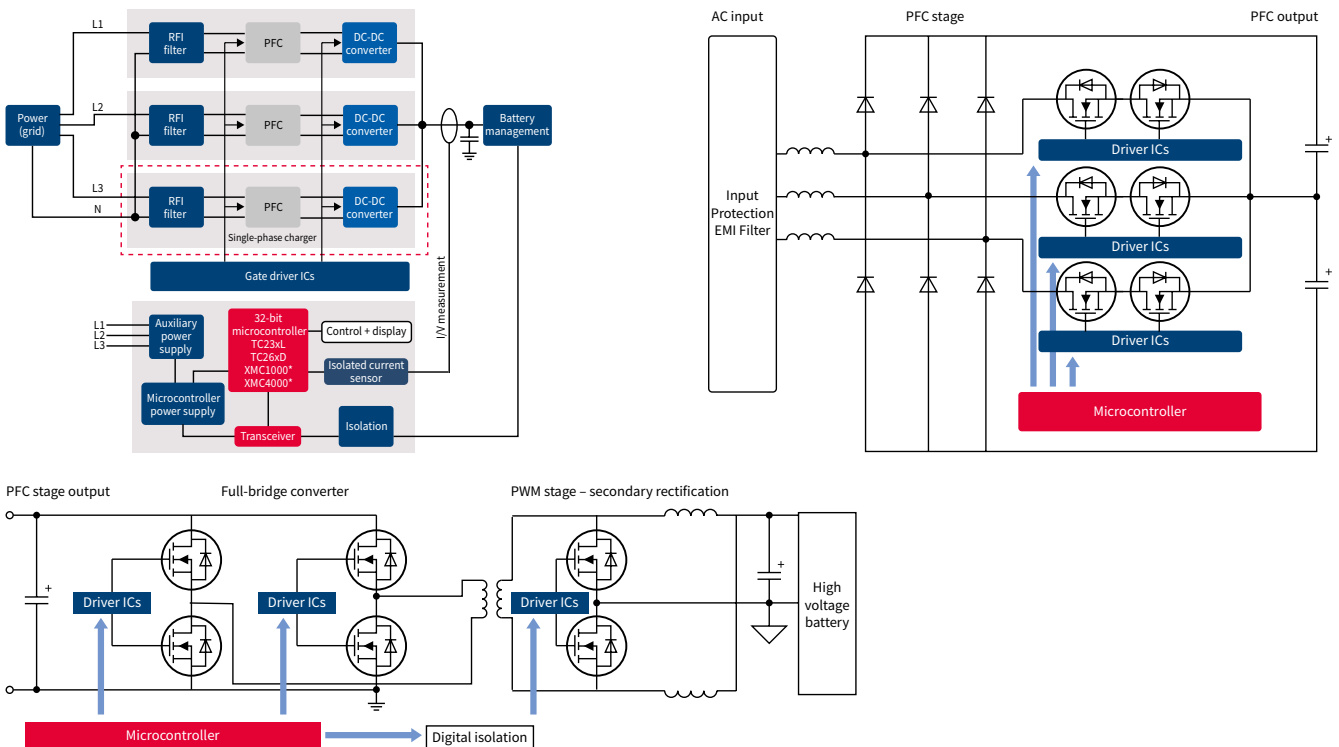

www.infineon.com/emobility

*For off-board chargers only

Product portfolio for onboard and off-board charger applications

Infinion's comprehensive portfolio of semiconductors (sensors, microcontrollers, power semiconductors, etc.) lends itself perfectly to designs of compact units for onboard, off-board, and wireless charging. Our products in this sector support high switching frequencies at lowest possible on-state resistance ($R_{DS(on)}$) to enable compact and efficient designs: MOSFETs such as CoolMOS™, IGBTs such as TRENCHSTOP™ 5 and SiC Schottky diodes, such as 650 V CoolSiC™ diode. In addition, integrated MOSFET and IGBT drivers, controller ICs for active CCM PFC high-performance microcontroller solutions and highly accurate current sensors complete our product portfolio. For more information about off-board chargers, refer to **page 46** DC EV charging.

Automotive products for onboard units

Typical part number	Product family	Description
1ED020112FA2	Automotive EiceDRIVER™	Single-channel isolated driver for 650 V/1200 V IGBTs and MOSFETs
1ED020112FTA	Automotive EiceDRIVER™	Single-channel isolated driver, two-level turn-off for 650 V/1200 V IGBTs
2ED020112FA	Automotive EiceDRIVER™	Dual-channel isolated driver for 650 V/1200 V IGBTs and MOSFETs
IPx65RxxxCFDA	CoolMOS™	650 V MOSFET with integrated fast body diode
TC23xL, TC26xD	AURIX™	32-bit lockstep microcontroller
TLF35584 ¹⁾	System supply	New ISO26262 – system-supply optimized for AURIX™
TLE7250G	Transceiver	High-speed automotive CAN transceiver
TLE6251D	Transceiver	High-speed automotive CAN transceiver, with wake-up

Industrial products for off-board units

Typical part number	Product family	Description
IKWxxN65F5/H5/EH5, IKZxxN65EH5/NH5	TRENCHSTOP™ 5 IGBTs	650 V ultrafast/fast IGBT with Rapid 1 diode
IGWxxN65F5/H5, IGZxxN65H5	TRENCHSTOP™ 5 IGBTs	650 V ultrafast/fast IGBT
IDWxxG65/120C5(B ³⁾)	CoolSiC™ diodes	650 V/1200 V SiC Schottky diode generation 5
IDWxxG120C5	CoolSiC™ diodes	1200 V SiC Schottky diode generation 5 TO-247 2-pin
IMW/Z120RxxxM1	CoolSiC™ MOSFETs	1200 V SiC MOSFETs
IPW65RxxxC7	CoolMOS™ SJ MOSFETs	650 V MOSFET, CoolMOS™ C7 series for hard switching topologies
IPW60RxxxP7	CoolMOS™ SJ MOSFETs	600 V MOSFET, CoolMOS™ P7 series for hard switching topologies
IPW65RxxxCFD	CoolMOS™ SJ MOSFETs	650 V MOSFET, CoolMOS™ CFD2 series for soft switching topologies
IPW60RxxxCFD7	CoolMOS™ SJ MOSFETs	600 V MOSFET, CoolMOS™ CFD7 series for soft switching topologies
HYBRIDPACKTM 1	Power module	1200 V/200 A for fast and ultrafast charging (>10 kW/phase)
XMC1000 ²⁾ , XMC4000 ²⁾	XMC™ microcontrollers	32-bit ARM® Cortex® M0/M4F microcontrollers, up to 125°C ambient temperature (XMC4000)
IFX1763, IFX54441, IFX54211	Linear voltage regulators	Linear voltage regulator family with output current capability of 500 mA/300 mA/150 mA respectively
IFX1050, IFX1021	Transceivers	High-speed CAN transceiver/LIN transceiver
TLI4970	Current sensor	600 V functional isolation, ± 50 A
2EDNxxxxF/R	EiceDRIVER™ 2EDN gate driver ICs	Dual-channel, low-side, non-isolated
1EDIxxN12AF	EiceDRIVER™ 1EDL Compact gate driver ICs	Single-channel, high-side isolated

Wireless charging

Wireless methods for power transfer to charge the batteries of electric vehicles are gaining attention. Several concepts for wireless power transfer systems have been proposed, which in general seek to compensate the significant stray inductances on primary and secondary sides of the magnetic couplers by adaptive resonant methods. At the end of 2013, SAE announced a new standard for inductive charging which defined three power levels at 85 kHz. Infineon's TRENCHSTOP™ 5 IGBTs and CoolSiC™ diodes are perfectly suited for driving inductive power transfer systems on the road side which operate inside the 80 to 90 kHz band.

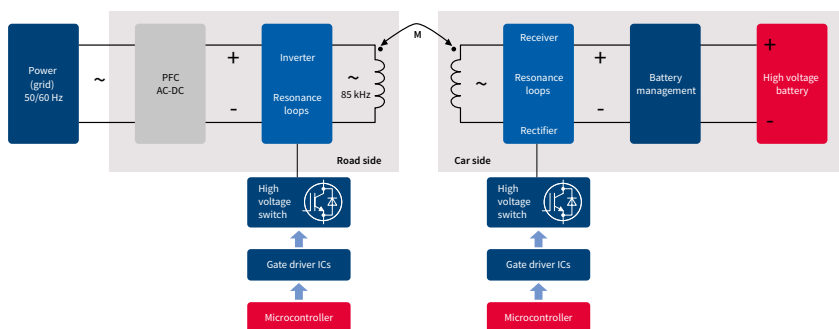

www.infineon.com/emobility

- 1) in development
- 2) for external chargers
- 3) „B“ in product name refers to common-cathode configuration

Automotive products for the car side*

Typical part number	Product family	Description
1ED020I12FA2	Automotive EiceDRIVER™	Single-channel isolated driver for 650 V/1200 V IGBTs and MOSFETs
1ED020I12FTA	Automotive EiceDRIVER™	Single-channel isolated driver, two-level turn-off for 650 V/1200 V IGBTs
2ED020I12FA	Automotive EiceDRIVER™	Dual-channel isolated driver for 650 V/1200 V IGBTs and MOSFETs
IPx65RxxxCFDA	CoolMOS™	650 V MOSFET with integrated fast body diode
TC23xL, TC26xD	AURIX™	32-bit lockstep microcontroller
TLF35584 ¹⁾	System supply	New ISO26262-system-supply optimized for AURIX™

Industrial products for the road side*

Typical part number	Product family	Description
IKW40N65F5	TRENCHSTOP™ 5 IGBTs	Fast IGBT with Rapid 1 diode, 40 A, TO-247
IGW40N65F5	TRENCHSTOP™ 5 IGBTs	Fast IGBT, single, 40 A, TO-247
IDW40G65C5	CoolSiC™ diode	650 V SiC Schottky diode generation 5, 40 A, TO-247 ²⁾
XMC4000	XMC™ microcontroller	32-bit ARM® Cortex® -M4F microcontrollers, up to 125 °C ambient temperature
IFX1763, IFX54441	Linear voltage regulators	Linear voltage regulator family with output current capability of 500 mA or 300 mA respectively
TLI4970	Current sensor	600 V functional isolation, ± 50 A

*Available in different current ratings

Charger concepts without galvanic isolation of the power stages

Transformerless designs, without galvanic isolation inside the power stages, are economic and efficient. But enhanced safety measures may be required to operate such designs from standard AC-grid power outlets. Type-B RCD (GFCI) safety switches are needed on the grid side to immediately break the circuit in case an unintended feedback of DC-voltage from the HV-battery into the AC-grid occurs under worst-case failure conditions, but type-B safety switches on the grid side are not standard by today. The main reason why non-isolated designs are currently not accepted for onboard chargers is because the level of safety measures on the grid side of the charging spot is uncertain. However, inside an off-board charger installation with an integrated type-B safety switch, the use of non-isolated concepts may be indicated. To highlight their opportunities, Infineon has investigated non-isolated concepts, built and evaluated laboratory demonstrators of single-phase 3 kW chargers without galvanic isolation inside the power stages.

Concept demonstrator³⁾ of lean and efficient off-board DC-charger without galvanic isolation

- > Input 230 V/50 Hz single-phase AC
- > Output 220 V-390 V_{DC}, max. power 3.3 kW at 350 V with 96.2 percent efficiency

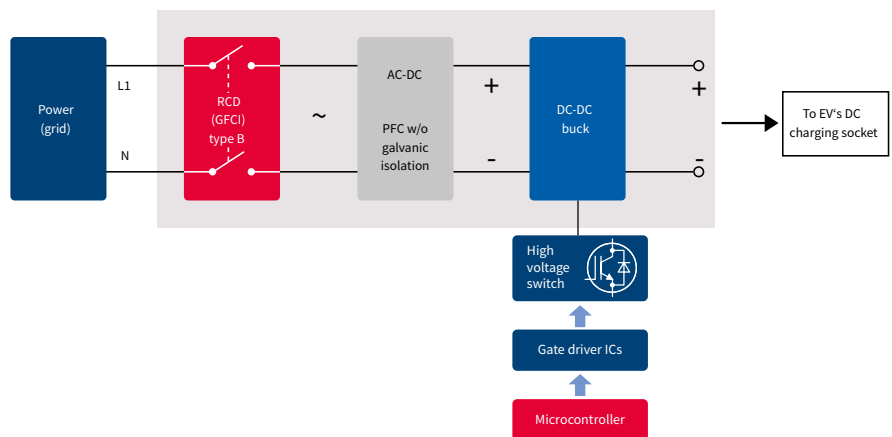

Industrial products for the road side

Typical part number	Product family	Description
ICE3PCS01G	Integrated controller	For active CCM PFC, DSO 14-pin
IPW65R019C7	CoolMOS™ C7 SJ MOSFET	650 V MOSFET, 19 mΩ, TO-247
IDW30G65C5	CoolSiC™ diode	650 V SiC Schottky diode generation 5, 30 A, TO-247
TLI4970	Current sensor	600 V functional isolation, ± 50 A

www.infineon.com/emobility

1) In development

2) Automotive version under consideration

3) More detailed information about this demonstrator is available upon request

Best solution for battery management

An intelligent battery management system (BMS) is necessary to sustain battery performance throughout its entire lifetime – the challenge there is to tune the utilization of each battery cell individually. Passive cell balancing is the default approach where the weakest of the cells sets the limits for battery lifetime and cruising range. Infineon's microcontrollers and sensors, in combination with our power devices, enable active cell balancing while charging and discharging. An active cell balancing system helps to increase the effective cruising range and the battery lifetime by 5 to 10 percent, compared to passive balancing. In this context, highlights are our 8-bit XC886CM microcontroller family for the slave blocks and the new 32-bit AURIX™ microcontroller family for the master block, OptiMOS™ low voltage MOSFETs, automotive CAN transceivers TLE7250G, TLE6251D, as well as step-down DC-DC controllers TLE6389-2GV and brand-new TLF35584.

Main switch

Typical part number	Product family	Description
IPx65RxxxCFDA	CoolMOS™ CFDA	650 V SJ MOSFET with integrated fast body diode

Battery master

Typical part number	Description
TC23xL, TC26xD	32-bit AURIX™ lockstep microcontrollers
TLF35584 ¹⁾	ISO26262-system-supply optimized for AURIX™
TLE7250G	High-speed automotive CAN transceiver
TLE6251D	High-speed automotive CAN transceiver, with wake-up

Battery master

Typical part number	Description
XC886CM	8051-compatible 8-bit automotive microcontroller
TLE6389-2GV	Step-down DC-DC controller
TLE7250G	High-speed automotive CAN transceiver
IPG20N04S4L	OptiMOS™ -T2 power transistor, logic level, dual, 40 V/8.2 mW
IPD70N03S4L	OptiMOS™ -T2 power transistor, logic level, 30 V/4.3 mW
IPD70N10S3L	OptiMOS™ -T2 power transistor, logic level, 100 V/11.5 mW

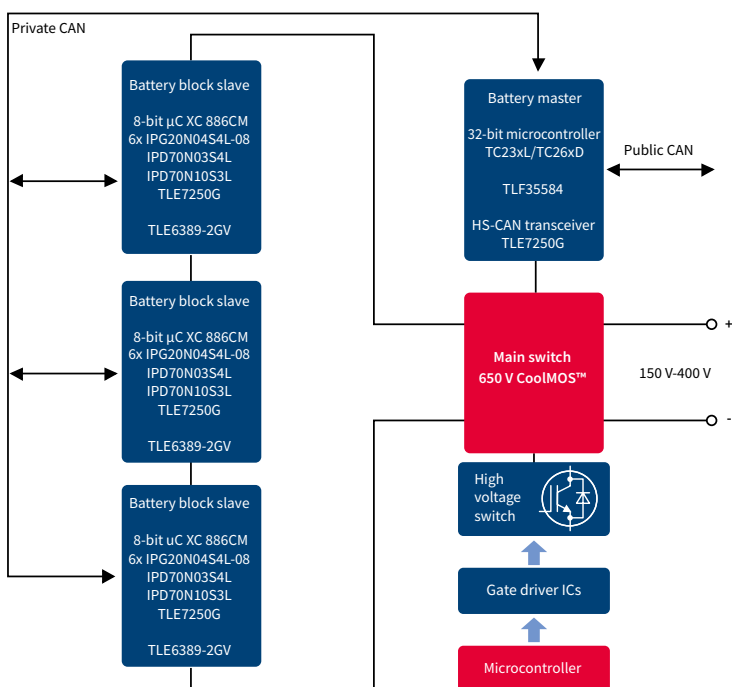

www.infineon.com/emobility

1) In development



Class D audio solutions

Cooler, smaller and lighter amplifiers for great sounding audio products

Infineon's audio solutions enable audio designers to improve the performance of their products, while increasing efficiency and reducing solution size. Advances in semiconductor processes in combination with new innovative architectures are behind a portfolio of class D technologies that allow professional, commercial/home and portable audio applications to benefit from unparalleled performance, power density and reliability.

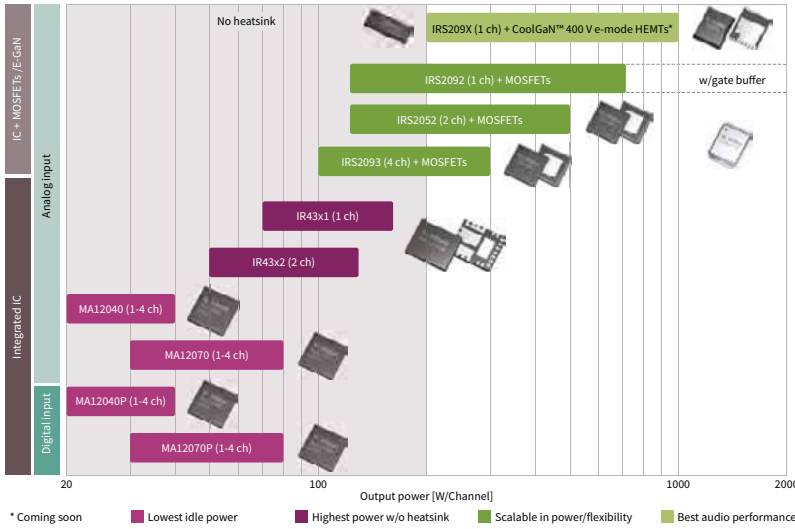

Infineon's advantage

Infineon offers a unique design platform with high-performance class D amplifier solutions for all power ranges and applications between 20 W and 2000 W per channel - from the smallest fully integrated single-chip solutions to highly scalable driver and discrete MOSFET combinations.

Integrated audio solutions

MERUS™ integrated multilevel audio amplifier ICs for class D audio solutions

With the revolutionary multilevel class D audio amplifier ICs, Infineon is leading in efficiency and power density. Monolithic multilevel class D amplifier ICs give designers full flexibility to optimize audio systems for size, performance, and cost to meet critical design objectives in today's and tomorrow's audio applications. These applications include battery operated speakers, voice controlled active speakers, television sets, stereo HiFi, soundbars, monitors, power-over-ethernet (PoE) and multichannel systems.

Filterless topology with "flying capacitor" of an integrated class D IC

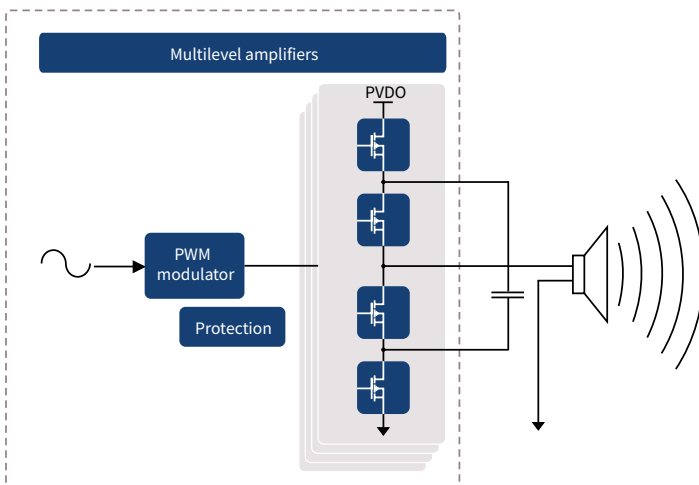

www.infineon.com/audiosolutions



MERUS™ integrated audio amplifier multi-chip modules (MCM)

The integrated class D audio module family of devices integrates PWM controller and digital audio power MOSFETs in a single package to offer a highly efficient, compact solution that reduces component count, shrinks PCB size up to 70 percent and simplifies class D amplifier design.

Multi-chip audio amplifier module

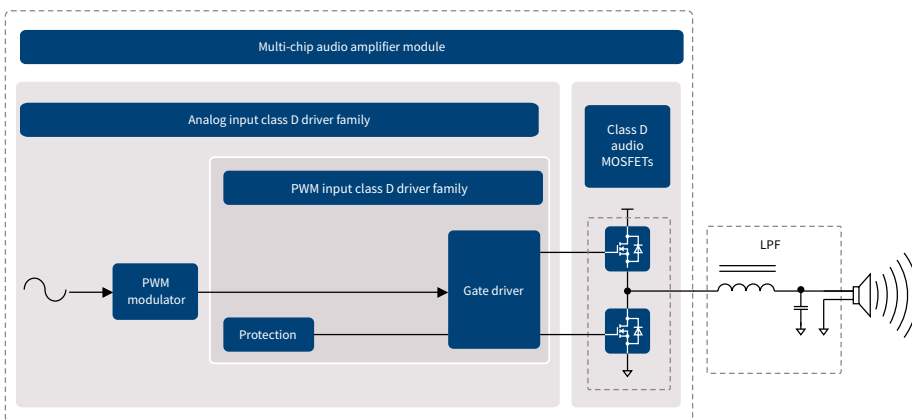

Discrete audio solutions

MERUS™ discrete audio amplifier driver ICs

Infineon's family of ICs developed specifically for class D audio applications enable audio system manufacturers to more efficiently design audio product with superior audio performance and higher reliability.

Recommended audio MOSFETs

Audio MOSFETs are specifically designed for class D audio amplifier applications. Key parameters, such as on-state resistance ($R_{DS(on)}$), gate charge (Q_G), and reverse recovery charge (Q_{rr}), are optimized for maximizing efficiency, THD and EMI amplifier performance.

www.infineon.com/audiosolutions

Integrated class D audio solution portfolio

MERUS™ integrated multilevel audio amplifier IC portfolio

		MA12040	MA12040P	MA12070	MA12070P
Specifications	Number of audio channels	2xBTL/2xSE/1xPBTL	2xBTL/2xSE/1xPBTL	2xBTL/2xSE/1xPBTL	2xBTL/2xSE/1xPBTL
	Max. peak power @ 4 Ω 10% THD	2x40 W	2x40 W	2x80 W	2x80 W
	Supply voltage	4-18 V	4-18 V	4-26 V	4-26 V
	3-level and 5-level modulation	✓	✓	✓	✓
	Max. PWM frequency	726 kHz			
	Audio input	Analog	Digital	Analog	Digital
	Hi-Res audio compliant		✓		✓
	Volume and dynamic range control		✓		✓
	Idle power dissipation Max output and all channels switching	<100 mW	<110 mW	<160 mW	<160 mW
	Audio performance (PMP2)	>107 dB DNR 55 μV output noise 0.003% THD+N	>98 dB DNR 135 μV output noise 0.006% THD+N	>110 dB SNR 45 μV output integrated 0.004%THD+N	101 dB SNR 140 μV output noise 0.007% THD+N
	Features	Comprehensive protection scheme*	✓	✓	✓
Configurable for SE or PBTL operation		✓	✓	✓	✓
I ² C communication		✓	✓	✓	✓
Filterless implementation		✓	✓	✓	✓
Package type		64-pin QFN package with exposed thermal pad	64-pin QFN package with exposed thermal pad	64-pin QFN package with exposed thermal pad	64-pin QFN package with exposed thermal pad
Evaluation boards		EVAL_AUDIO_MA12040	EVAL_AUDIO_MA12040P	EVAL_AUDIO_MA12070	EVAL_AUDIO_MA12070P

*All ICs carry a full protection scheme comprising undervoltage-lockout, overtemperature warning/error, short-circuit/overload protection, power stage pin-to-pin short-circuit, error-reporting through serial interface (I²C), DC protection.

MERUS™ integrated audio amplifier multi-chip module (MCM) portfolio

		IR4301M	IR4321M	IR4311M	IR4302M	IR4322M	IR4312M
Specifications	Number of audio channels	1	1	1	2	2	2
	Max. power per channel	160 W	90 W	45 W	130 W	100 W	40 W
	Supply voltage	~ ±31 V or 62 V	~ ±25 V or 50 V	~ ±15 V or 30 V	~ ±31 V or 62 V	~ ±25 V or 50 V	~ ±16 V or 32 V
	Max. PWM frequency	500 kHz	500 kHz	500 kHz	500 kHz	500 kHz	500 kHz
Features	Differential audio input	✓	✓	✓	✓	✓	✓
	Over-current protection	✓	✓	✓	✓	✓	✓
	Integrated power MOSFET	(80 V)	(60 V)	(40 V)	(80 V)	(60 V)	(40 V)
	PWM controller	✓	✓	✓	✓	✓	✓
	Thermal shutdown	✓	✓	✓	✓	✓	✓
	Click noise reduction	✓	✓	✓	✓	✓	✓
	Clip detection				✓	✓	✓
	Fault output				✓	✓	✓
	Package type	5 x 6 mm QFN	5 x 6 mm QFN	5 x 6 mm QFN	7 x 7 mm QFN	7 x 7 mm QFN	7 x 7 mm QFN
	Evaluation boards	IRAUDAMP12, IRAUDAMP19	IRAUDAMP21	IRAUDAMP15	IRAUDAMP16, IRAUDAMP17	IRAUDAMP22	IRAUDAMP18

Discrete class D audio solution portfolio

MERUS™ discrete audio amplifier driver IC product portfolio

		IRS20965S	IRS20957S	IRS2092S	IRS2052M	IRS2093M	IRS2452AM
Specifications	Number of audio channels	1	1	1	2	4	2
	Max. power per channel	500 W	500 W	500 W	300 W	300 W	500 W
	Supply voltage	±100 V	±100 V	±100 V	±100 V	±100 V	±200 V
	Gate sink/source current	2.0/2.0 A	1.2/1.0 A	1.2/1.0 A	0.6/0.5 A	0.6/0.5 A	0.6/0.5 A
Features	Over-current protection	✓	✓	✓	✓	✓	✓
	Over-current flag	✓					
	PWM input	✓	✓				
	Floating input	✓	✓	✓	✓	✓	✓
	Dead time		✓	✓	✓	✓	✓
	Protection control logic	✓	✓	✓	✓	✓	✓
	PWM controller			✓	✓	✓	✓
	Clip detection				✓		
	Click noise reduction			✓	✓	✓	✓
	Temperature sensor input				✓		✓
	Thermal shutdown				✓		
	Clock input				✓		✓
	Package type	16-pin SOIC narrow	16-pin SOIC narrow	16-pin SOIC narrow	MLPQ48	MLPQ48	MLPQ32
	Evaluation boards	-	IRAUDAMP4A, IRAUDAMP6	IRAUDAMP5, IRAUDAMP7S, IRAUDAMP7D, IRAUDAMP9	IRAUDAMP10	IRAUDAMP8	EVAL_IRAUDAMP23

Recommended audio MOSFET (through-hole) portfolio

Output power [W]	Recommended driver IC	Speaker resistance		
		2 Ω	4 Ω	8 Ω
150	IRS2093S*	IRFB4019	IRFB4019	IRFI4020H
200	IRS2052M*	IRFB5615	IRFB4019	IRFI4020H
300	IRS2092S**	IRFB4228	IRFB4227	IRFB4229
500	IRS20957S**	IRFB4228	IRFB4227	IRFB4229
750		IRFB4227	IRFB4229	
1000		IRFP4668	IRFB4229 x 2	

Recommended audio MOSFET (DirectFET™) portfolio

Output power [W]	Recommended driver IC	Speaker resistance		
		2 Ω	4 Ω	8 Ω
150	IRS2093S*	IRF6645	IRF6665	IRF6775
200	IRS2052M*	IRF6646	IRF6775	IRF6775
300	IRS2092S**	IRF6644	IRF6775	IRF6785
500	IRS20957S**	IRF6643	IRF6641	

Recommended CoolGaN™ e-mode HEMTs portfolio

Package	CoolGaN 400 V e-mode HEMTs		Recommended audio driver IC
	PG-DSO-20-87 (top-side cooling)	HSOF-8-3 (TO-leadless)	
P _{max}	Up to 500 W	Up to 200 W	IRS20957S
R _{DS(on) max.}	70 mΩ	70 mΩ	
Part number	IGOT40R070D1	IGT40R070D1	

www.infineon.com/audiosolutions

www.infineon.com/gan

*IRS2093S works up to 150 W and IRS2052M works up to 300 W.

**IRS2092S and IRS20957S work with all power levels listed above.



DC-DC enterprise power solution for data processing applications

Multiphase and point-of-load DC-DC solution



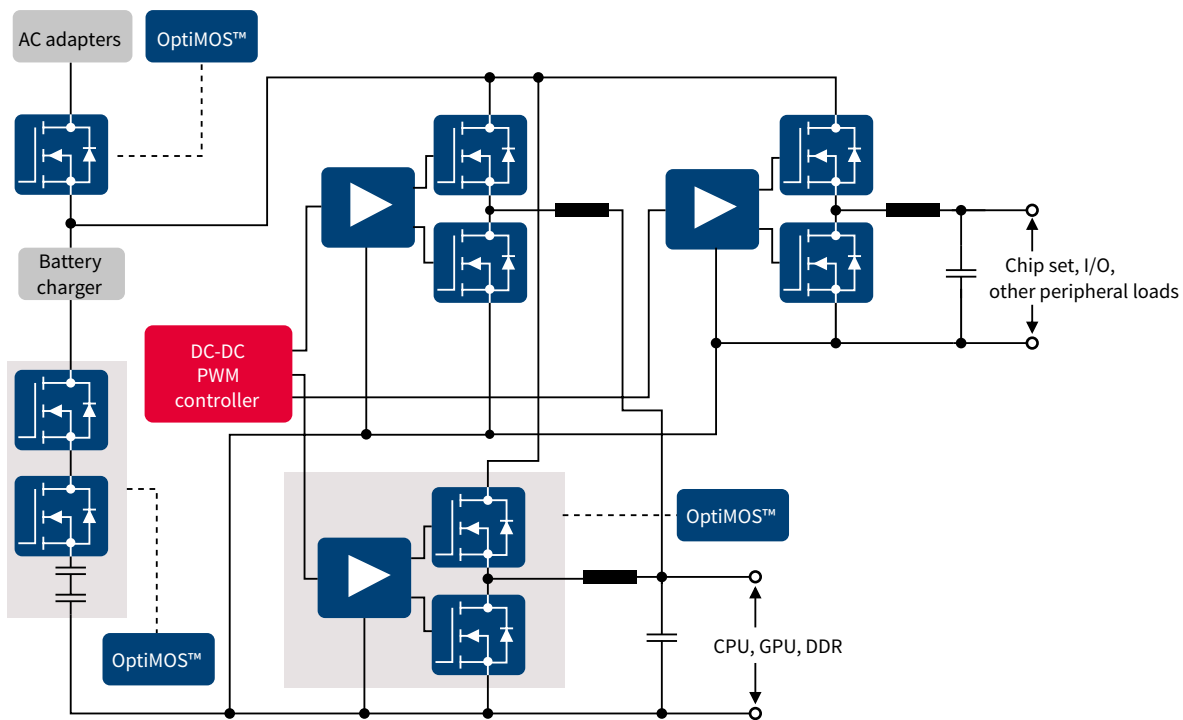

An industry leader in digital power management, Infineon delivers solutions for the next generation server, communication, storage and client computing applications. Infineon offers a complete portfolio, including digital PWM controllers, integrated power stages, integrated point-of-load (POL), MOSFET drivers, power blocks and discrete MOSFETs. These proven technologies offer full flexibility to our customers to optimize a complete system solution for space, performance, ease of design and cost to meet critical design goal objectives. In addition, our latest software tools help simplify design, shorten design cycles and improve time-to-market.



Benefit	Advantage
Best-in-class efficiency	Digital controller and power stage provide industry's best efficiency of more than 95 percent
Support all major VID interface and control schemes	Intel SVID, AMD SVI2, NVIDIA PWM VID, Parallel VID (up to 8-bit) , PMBus™ Rev1.3, AVS Bus (PMBus™ Rev1.3)
Complete system solution	A broad portfolio of fully integrated point-of-load, integrated power stage and digital controller solutions in addition to discrete drivers and MOSFETs offers full flexibility to optimize complete system solutions requiring 1 A to 300 A+, single output/single-phase to multiple output/multi-phase
Digital controller flexibility	The industry's benchmark full featured 8-phase, multiple output, flexible configuration digital controllers
Ease of design	GUI-based optimization and configuration significantly reduces design cycle time
Smallest solution size	High density packaging and unique control schemes enable reduced external component count and overall board space



Multiphase DC-DC system solution

	Server/storage	Powered ICs	Voltage	
 	Server-Intel/IBM/AMD/ARM Workstation Storage	Server chip set	VCCIO	V_{core}
			VMCP	V_{mem}
	High-end consumer High-end desktop Graphic Notebook Industrial PC Gaming	PC chip set		V_{core}
				Graphics
 	Comms Datacom Comms core SOHO SAN Edge access	Telecom Base station (macro + distributed)	ASIC ASSP FPGA	Networking SoCs and ASICs, FPGAs
			FPGAs (~0.5–3.3 V) ASICs (~1.0 V) ASSPs (~1.0 V)	Multi-core processors Ethernet switch ICs
			10-30 A single-phase (multi-rail)	>30 A multi-phase/rail



DC-DC enterprise power solution for data processing applications

Integrated point-of-load converters

Infiniteon's point-of-load converters integrate a PWM controller, driver and MOSFETs into a small PQFN package for ease of use. The patented PWM modulation scheme allows greater than 1 MHz switching frequencies to deliver ultracompact layouts and the smallest bill of materials. A PMBus™ interface is available for monitoring and control in systems that use advanced CPUs, ASICs and FPGAs.

Block diagram

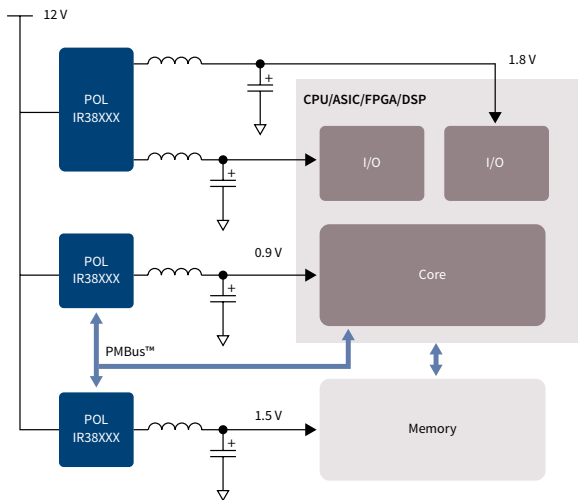

Key features

- > Input voltage range 4.5-21 V
- > Output current 1-35 A
- > Operating temperature range of -40 to 125°C

Key benefits

- > Integrated controller, driver, MOSFETs for small footprint
- > High efficiency MOSFETs and thermally enhanced packages for operation without heat sinks

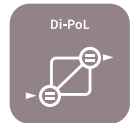

DC-DC IPOL portfolio

Digital interface IPOL

I ² C PMBus™, telemetry, margin, faults, SVID PVID Digital control/configuration, telemetry and diagnostic					
Part number	Max. current [A]	Package size [mm]	Max. V _{in}	Max. f _{sw}	Distinctive features
IR38064	35	5 x 7	21 V	1500 KHz	PMBus™
IR38063	25	5 x 7	21 V	1500 KHz	
IR38062	15	5 x 7	21 V	1500 KHz	
IR38060	6	5 x 6	16 V	1500 KHz	
IR38163	30	5 x 7	16 V	1500 KHz	OptiMOS™ 5, SVID + PMBus™
IR38165	30	5 x 7	16 V	1500 KHz	OptiMOS™ 5, SVID
IR38363	15	5 x 7	16 V	1500 KHz	OptiMOS™ 5, SVID + PMBus™
IR38365	15	5 x 7	16 V	1500 KHz	OptiMOS™ 5, SVID
IR38263	30	5 x 7	16 V	1500 KHz	OptiMOS™ 5, PVID + PMBus™
IR38265	30	5 x 7	16 V	1500 KHz	OptiMOS™ 5, PVID
IR38164	30	5 x 7	16 V	1500 KHz	OptiMOS™ 5, SVID + PMBus™, enhanced Imon
IRPS5401	4+4+2+2+0.5	7 x 7	14 V	1500 KHz	5 output PMIC, PMBus™

Analog interface IPOL

„Performace“ voltage mode PWM Ultralow jitter and noise, high accuracy and low ripple					
Part number	Max. current [A]	Package size [mm]	Max. V _{in}	Max. f _{sw}	Distinctive features
IR3883	3	3 x 3	14 V	800 KHz	Constant-on-time
IR3823	3	3.5 x 3.5	21 V	1500 KHz	3 soft start
IR3897	4	4 x 5	21 V	1500 KHz	DDR tracking and analog voltage margin/AVSO
IR3898	6	4 x 5	21 V	1500 KHz	
IR3899	9	4 x 5	21 V	1500 KHz	
IR3894	12	5 x 6	21 V	1500 KHz	
IR3895	16	5 x 6	21 V	1500 KHz	
IR3826	23	5 x 6	17 V	1500 KHz	OptiMOS™ 5, 3-level OCP
IR3826A	16	5 x 6	17 V	1500 KHz	OptiMOS™ 5, 3-level OCP
IR3448	16	5 x 6	21 V	1500 KHz	True differential remote sensing for accuracy and thermally enhanced Cu clip package
IR3847	25	5 x 6	21 V	1500 KHz	
IR3846	35	5 x 7	21 V	1500 KHz	
IR3891	4+4	5 x 6	21 V	1500 KHz	Dual output for density and out-of-phase for less input capacitor
IR3892	6+6	5 x 6	21 V	1500 KHz	

www.infineon.com/dataprocessing

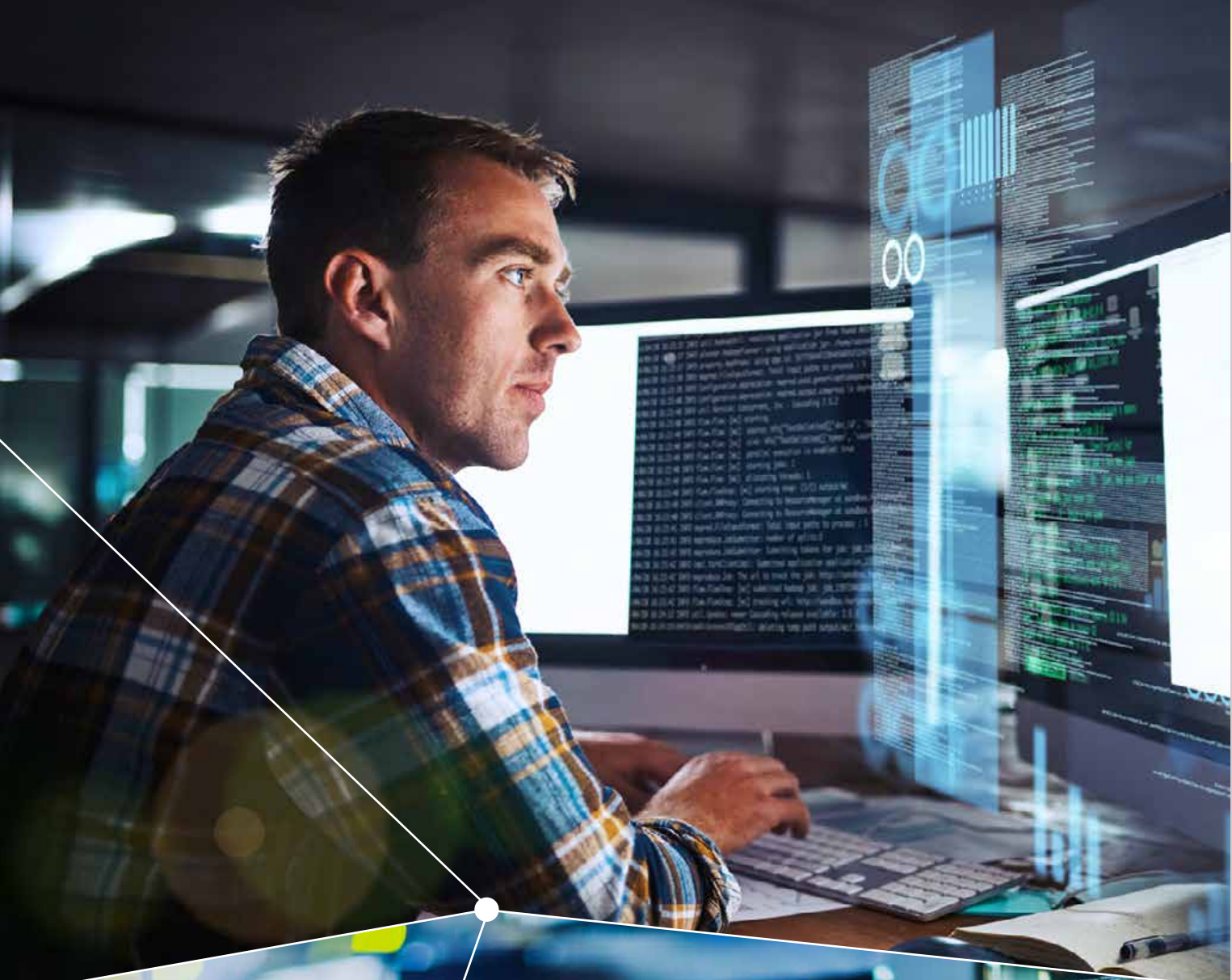

Applications
20-300 V MOSFETs
500-950 V MOSFETs
WBG semiconductors
Discrete IGBTs
Power ICS
Gate driver ICS
Motor control ICS
Microcontrollers
XENSIV™ sensors
Packages



Industrial welding*

High efficiency, easy design and cost competitive solutions

Discrete IGBTs are used in small inverterized single-phase handheld welders with current output from 120 to 200 A and three-phase industrial welding machines with current output up to 280 A. Infineon offers a wide product range to address key industry trends.

Price competitive 650 V TRENCHSTOP™ 5 WR5 series has been specifically developed for the low power single-phase welding machine market. The TRENCHSTOP™ 5 WR5 offers low switching losses coupled with low conduction losses to provide efficiency to customers and outstanding thermal performance.

For the best-in-class performance, where customers strive for differentiation, the 650 V TRENCHSTOP™ 5 H5 series offers outstanding efficiency for optimized, low inductance designs.

The new high speed, soft switching 650 V TRENCHSTOP™ 5 S5 series have soft and smooth switching behavior with no tail current, while keeping very competitive switching performance. The TRENCHSTOP™ 5 S5 series can be used as plug-and-play replacement of previous generations of Infineon's IGBTs. The low $V_{CE(sat)}$ 650 V TRENCHSTOP™ 5 L5 series is an excellent solution for secondary inverter AC output welding machines used for aluminum (Al) or magnesium (Mg) welding.

For three-phase welding inverters, the 1200 V HighSpeed 3 family keeps leading market position in >20 kHz designs with best performance/cost trade-off and highest reliability. For medium switching frequency designs, 1200 V TRENCHSTOP™ IGBT6 provides the best efficiency performance with a unique combination of low conduction losses of $1.85 \text{ V } V_{CE(sat)}$ and the lowest switching losses.

Typical topologies for inverter welding machine < 280 A

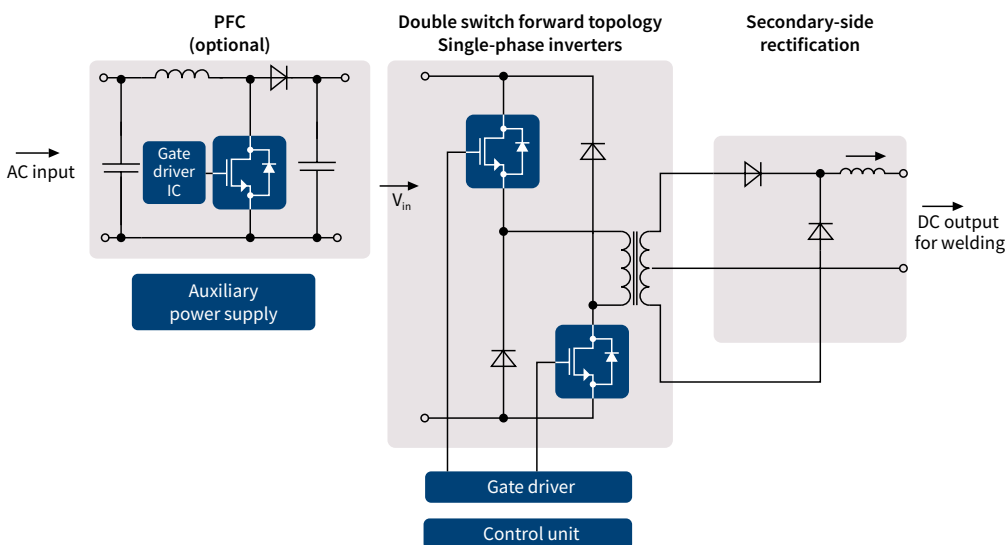

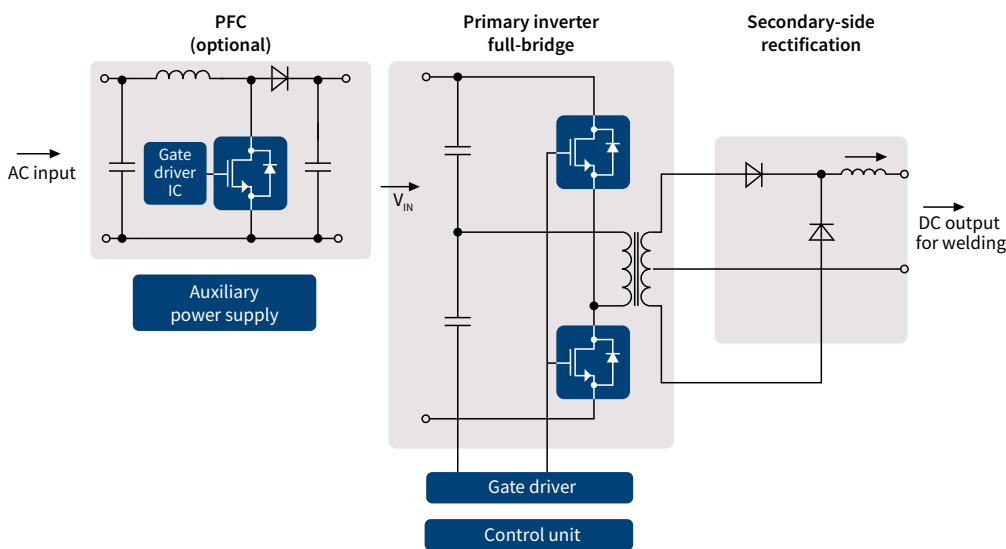

Infiniteon's product recommendation for industrial welding

Stage	Topology	Topology	Voltage class	Technology/product family	Selection/benefit
PFC	AC-DC	Boost converter/switch	650 V	TRENCHSTOP™ 5 WR5	Cost/performance
		Boost converter/switch	650 V	TRENCHSTOP™ 5 S5	Efficiency and ease of use
		Boost converter/switch	650 V	TRENCHSTOP™ 5 H5	Best efficiency
		Boost converter/switch	1200 V	TRENCHSTOP™ IGBT6	Efficiency
		Low-side gate driver	25 V	Single low-side driver 1ED44176N01F NEW!	OCF, fault and enable function in DSO-8
		Low-side gate driver	25 V	Dual low-side driver IRS4427S	Rugged and reliable in DSO-8
		Low-side gate driver	25 V	Single low-side driver IRS44273L	Rugged and reliable in SOT23-5
Inverter	DC-DC	Two transistor forward	650 V	TRENCHSTOP™ 5 WR5	Cost/performance
		Two transistor forward	650 V	Rapid 1 diode	Efficiency
		Full-bridge/half-bridge	650 V	TRENCHSTOP™ 5 WR5	Cost/performance
		Full-bridge/half-bridge	650 V	TRENCHSTOP™ 5 S5	Efficiency and ease of use
		Full-bridge/half-bridge	650 V	TRENCHSTOP™ 5 H5	Best efficiency
	Full-bridge	1200 V	TRENCHSTOP™ IGBT6	Efficiency	
DC-AC	Al/Mg welding secondary inverter	650 V	TRENCHSTOP™ 5 L5 Low $V_{CE(sat)}$	Efficiency	
DC-DC / DC-AC	Single high-side gate driver	1200 V	EiceDRIVER™ galvanic isolated 1EDI05112AF	1 A output current, separate sink/source outputs	
	Single high-side gate driver	1200 V	EiceDRIVER™ galvanic isolated 1EDI60N12AF	10 A output current, separate sink/source outputs	
Secondary side rectification	DC-DC	Output rectifier	650 V	Rapid 1 diode	Efficiency
		Output rectifier	650 V	Rapid 1 diode – common cathode	Efficiency
Controller	Auxiliary power control	Flyback control	800 V	CoolSET™ F5	Recommendation
		Boost converter	-	XMC1000	Flexibility
	Microcontroller supply	Linear voltage regulator	up to 20 V	IFX54211	Efficiency



LED lighting

Solutions for cost sensitive applications as well as for smart lighting

At Infineon, we focus on supplying tailored products for LED drivers, LED strips, horticultural, and smart lighting. Our broad portfolio of tailored products and solutions for LED lighting comprises LED driver ICs, MOSFETs, and microcontrollers suited for LED drivers as well sensors and dedicated ICs for secure communication. In addition to offering products of proven quality, a competent global lighting team supports our lighting customers in designing LED lighting products and systems in collaboration with our channel partners.

Key trends and challenges in LED lighting and our offering:

- › Light quality and human-centric light
 - No current ripple by using two stage topologies (i.e. ICL5102, XDPL8221, XDPL8218, BCR601)
 - Easy implementation of tunable white with a lighting dedicated peripheral – brightness and color control unit-BCCU (i.e. XMC1300)
- › Designing smaller and flatter LED drivers
 - Integrating up to 25 discrete components in one 0-10 V dimming interface IC (i.e. CDM10V)
 - High voltage SJ MOSFETs in small and cost-effective SOT-223 package
- › Smart lighting enabled by radar sensors
 - Reliable presence detection and large area coverage up to 300 m²
 - Integrated XENSIV™ 24 GHz radar transceiver eliminates the need on trimming and handling component tolerances
 - Ready-to-use module solutions with our radar partners (i.e. K-LD 2 from RF beam and INS-Serie from InnoSent), based on our XENSIV™ radar sensor IC (BGT24LTR11)



LED drivers

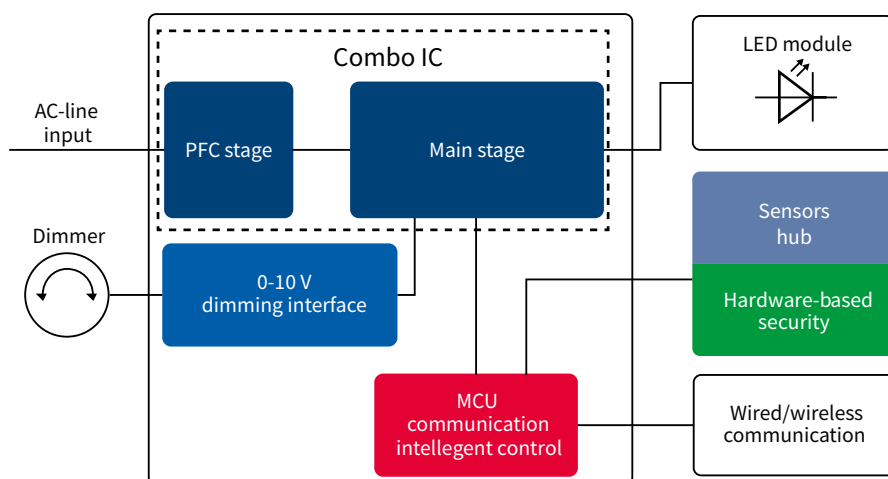

Recommended LED driver products

Functional block	Product type	IC product family	MOSFET technology	Voltage class
PFC stage	PFC	IRS2505	CoolMOS™ P7	600/700/800/950 V ¹⁾
Main stage	PFC + LCC (constant current) PFC + LLC (constant current)	ICL5102 ²⁾	CoolMOS™ P7 (up to 600 mΩ)	600 V/650 V
			CoolMOS™ CE (above to 600 mΩ)	600 V
	PFC + flyback (dual stage)	XDPL8220 ³⁾ / XDPL8221 ²⁾	CoolMOS™ P7	800 V/950 V
	PFC/flyback (single-stage constant voltage)	XDPL8105	CoolMOS™ P7	800 V/950 V
	PFC/flyback (single-stage constant voltage)	XDPL8218	CoolMOS™ P7	800 V/950 V
Buck / linear solutions	Secondary buck (single-channel) Secondary buck (multichannel)	ILD6150 / ILD8150	Integrated	60 V/80 V
		XMC1300 / XMC1400 ¹⁾	OptiMOS™	100 V/150 V/ 200 V/250 V/ 300 V
	Secondary linear	BCR601	OptiMOS™	75 V/100 V
Synchronous rectification	Synchronous rectification controller	IR1161 / IR11688	OptiMOS™	100 V/150 V/200 V
Dimming	0-10 V dimming interface IC	CDM10V	-	-
		CDM10VD	-	-
Hardware based security	OPTIGA™	OPTIGA™ Trust	-	-
MCU	XMC™ microcontroller	XMC1100	-	-
Sensors	XENSIV™ radar sensor IC	BGT24LTR11	-	-

LED driver with constant voltage output and linear/switch mode LED driver ICs

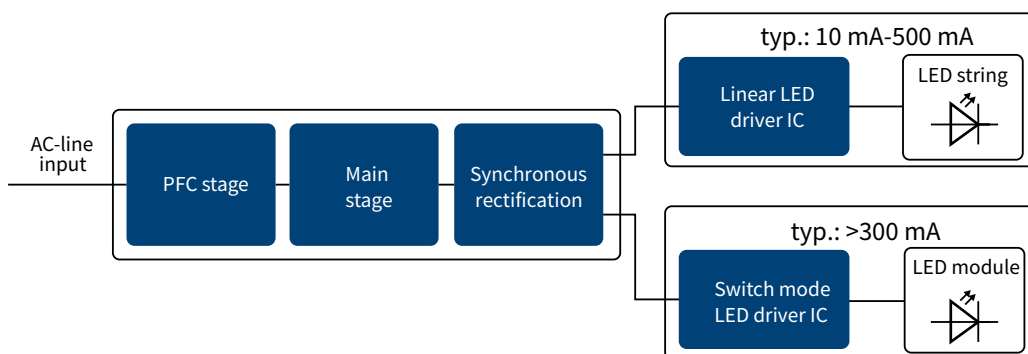

Linear/switch mode LED driver IC product portfolio

Functional block	Topology	IC product family	MOSFET technology	Voltage class
Linear LED driver IC	Linear	BCR400 series	Integrated (extra transistor for BCR450)	-
		BCR602	External N-channel MOSFET	75 V / 100 V
Switch mode LED driver IC	Buck	ILD6000 series	Integrated	-
		XMC1300/XMC1400*	OptiMOS™	100 V/150 V/200 V/250 V/ 300 V
	Buck/boost	ILD1151	OptiMOS™	60 V/100 V

* Including communication



Major home appliances

Innovative approach for air conditioning

Product designers are facing the daunting challenge of delivering smaller, smarter, more powerful and more energy-efficient appliances. Based on industry-leading technology and manufacturing expertise, Infineon's line of innovative components for household appliances meets and exceeds even the most rigorous requirements for reliability and quality. The following block diagram example of an air conditioning system, together with the product selection table, provides effective recommendation for engineers selecting the right component for each power management stage inside major home appliances.

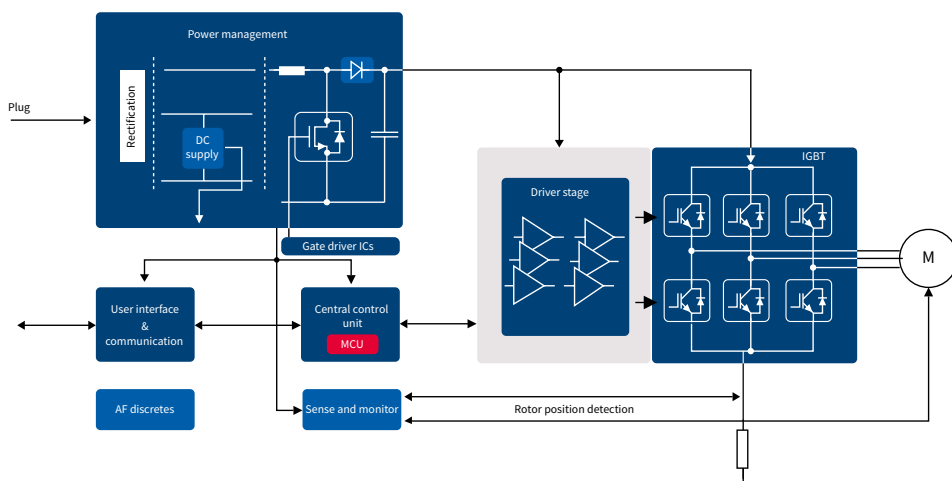

Functional block	Topology	Voltage class	Technology/product family	Selection/benefit
PFC AC-DC	IGBT – PFC CCM (high frequency – SC)	600 V	HighSpeed 3	Recommendation
	IGBT – PFC CCM (low frequency – SC)	600 V	TRENCHSTOP™ Performance	Recommendation
	IGBT – PFC CCM (cost competitive – no SC)	650 V	TRENCHSTOP™ 5 – H5	Recommendation
	IGBT – PFC CCM (low losses – SC)	650 V	TRENCHSTOP™ IGBT6	Recommendation
	IGBT – PFC	600 V	TRENCHSTOP™ Advanced Isolation	Recommendation
	IGBT – PFC (cost competitive – no SC)	650 V	TRENCHSTOP™ 5 WR5	Recommendation
	MOSFET – PFC CCM	600 V	CoolMOS™ P7	Reference
	Diode – PFC CCM	650 V	Rapid 1 and Rapid 2 diodes	Recommendation
	Controller – PFC CCM	-	ICE2PCS0xG, ICE3PCS0xG	Recommendation
	IPM – PFC CCM	650 V	CIPOS™ Mini PFC interleaved IPM series, CIPOS™ PFC integrated IPM series	Recommendation
	Low-side gate driver IC-PFC	25 V	Single low-side driver 1ED44176N01F NEW! Dual low-side driver IRS4427S Single low-side driver IRS44273L	OCF, fault and enable function in DSO-8 Rugged and reliable in DSO-8 Rugged and reliable in SOT23-5
DC-AC	IGBT – B6-VSI	650 V	TRENCHSTOP™ IGBT6	Efficiency
	IGBT – B6-VSI	600 V	RC-Drives Fast	Recommendation
	MOSFET – B6-VSI	500 V/600 V	CoolMOS™ CE	Cost/performance
	IPM – B6-VSI	600 V	CIPOS™ Mini	Recommendation
	Half-bridge gate driver IC	650 V	2ED2304S06F NEW!	SOI with integrated bootstrap diode
	Half-bridge gate driver ICs	600 V	2EDL05I06PF, 2EDL23I06PJ, IRS2890DS	Integrated bootstrap diode/FET
	Three-phase gate driver ICs	600 V	6EDL04I06PT, IR2136S, 6ED003L06-F2	OCF, fault and enable function
AUX	Flyback fixed frequency	700 V	CoolSET™ F5	Recommendation
Microcontroller/motor control IC	32-bit ARM® Cortex®-M4	-	XMC4100/XMC4200	Recommendation
	iMOTION™	-	IRMCxx motor control IC (incl. motion control algorithm)	Recommendation
Microcontroller supply	Linear voltage regulator	Up to 20 V	IFX1763, IFX54441, IFX54211, IFX3008	Efficiency
Communication	CAN transceiver	-	IFX1050, IFX1051, IFX1040	Robustness
Position sensing	Angle sensor	-	TLE5009, TLI5012B	Recommendation
	Hall switch	-	TLI496x	Recommendation

www.infineon.com/homeappliance



Major home appliance

Highest performance and efficiency for induction cooking

Resonant-switching applications such as induction cooktops and inverterized microwave ovens have unique system requirements. The consumer marketplace demands them to be cost-effective, energy efficient and reliable. To achieve these goals, designers need solutions that are developed specifically for these applications.

Infineon's RC discrete IGBTs were developed for resonant switching with a monolithically integrated reverse conducting diode. With this technology leadership and a broad portfolio of devices from 650 to 1600 V, Infineon is the market leader and provides the industry benchmark performance in terms of switching and conduction losses.

The latest RC-H5 family, previously offered with blocking voltage of 1200 V and 1350 V in a wide current range from 20 to 40 A, is now completed with the addition of a new 30 A 1600 V IGBT.

The TRENCHSTOP™ Feature IGBT protected series (protected IGBT) is a new device in the IGBT portfolio for induction heating application, which adds new functionality to standard discrete IGBTs. The innovative protected IGBT combines a 20 A 1350 V IGBT in RC-H5 technology with a unique protecting gate driver IC in a TO-247 6-pin package.

The RC-E family is cost- and feature-optimized specifically for low- to mid-range induction cookers and other resonant applications. This new family offers Infineon's proven quality in RC IGBTs with the best price-performance ratio and ease of use. Infineon also offers a range of complementary products, such as low-side gate drivers and high voltage level-shift gate drivers which can be used with the IGBTs, as well as in the central control and power supply subsystems of induction cooking appliances.

Induction heating inverter (current resonance) Half-bridge

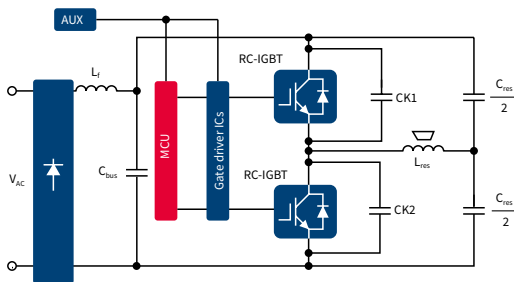

Induction heating inverter (voltage resonance) Single switch

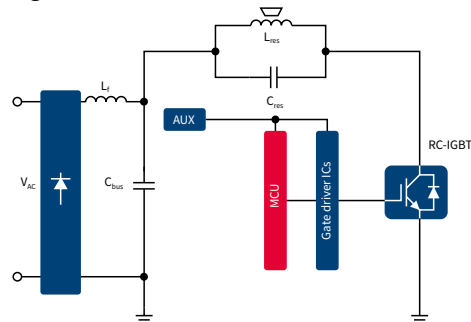

Induction heating	Topology	Voltage class	Technology/product family	Selection/benefit
DC-AC	Series-resonant half-bridge	650 V	RC-H5	Recommendation
	Quasi-resonant single switch	1100 V	RC-H3	Recommendation
	Quasi-resonant single switch	1200 V	RC-H5, RC-E	Recommendation
	Quasi-resonant single switch	1350 V	RC-H5	Recommendation
	Quasi-resonant single switch	1600 V	RC-H2	Recommendation
	Quasi-resonant single switch and protective driver	1350 V	RC-H5/protected IGBT	Recommendation
Gate driver ICs	Single low-side gate driver	25 V	1ED44176N01F, IRS44273L	1ED integrated with OPC, fault and enable functions
	Half-bridge gate driver	650 V	2ED2304S06F	SOI with integrated bootstrap diode
	Single high-side gate driver	1200 V	1EDI40I12AF, 1EDI30I12MF	Galvanic isolation, separate sink/source output
Microcontroller	32-bit ARM® Cortex®-M0	-	XMC1302	Recommendation
Microcontroller supply	Linear voltage regulator	Up to 20 V	IFX54211	Efficiency
AUX	Fixed-frequency flyback	700 V	CoolSET™ F5	Recommendation

www.infineon.com/homeappliance



Multicopter

Reliable and cost-effective solutions to support future design trends

Initially regarded as toys, multicopters are now serious business. From FPV drone racing to the observation of remote places or even future delivery solutions, entire businesses are emerging around the design, supply, and the use of multicopters. The major differentiator between toy drones and professional multicopters is the complexity of the control system. In professional applications, multicopters must provide a useful function on top of mere flying. Most often, this is a vision system that requires video processing, gimbal control, and other functionalities which are integrated into the control system. With great development progress in the field of data processing, navigation and control, the overall system performance is determined from reliable and efficient power management.

Multicopter solutions from Infineon

Infineon's comprehensive portfolio of high quality products allows designers to rapidly design, develop, and deploy systems that address the ever more demanding needs of today's customers. We offer a near system solution – everything from XMC™ microcontrollers, to iMOTION™ motor control ICs, to magnetic sensors and many other cutting-edge technologies – with the exception of one commodity, an IMU (inertial measurement unit) for existing solutions. In the very fast growing multicopter market, energy efficiency and reliability are becoming more important. Camera applications, autonomous flying and sophisticated onboard equipment are pushing the limits of power management and reliability. With increased adoption comes increased regulation and the multicopter itself needs to be capable of being piloted in a safe and well-controlled manner. Being a recognized leader in automotive and industrial power electronic systems, Infineon offers high quality system solutions for the next generation of multicopters and enables customers to achieve a higher degree of innovation and differentiation.

Overview of the main electronic subsystems of a typical multicopter design

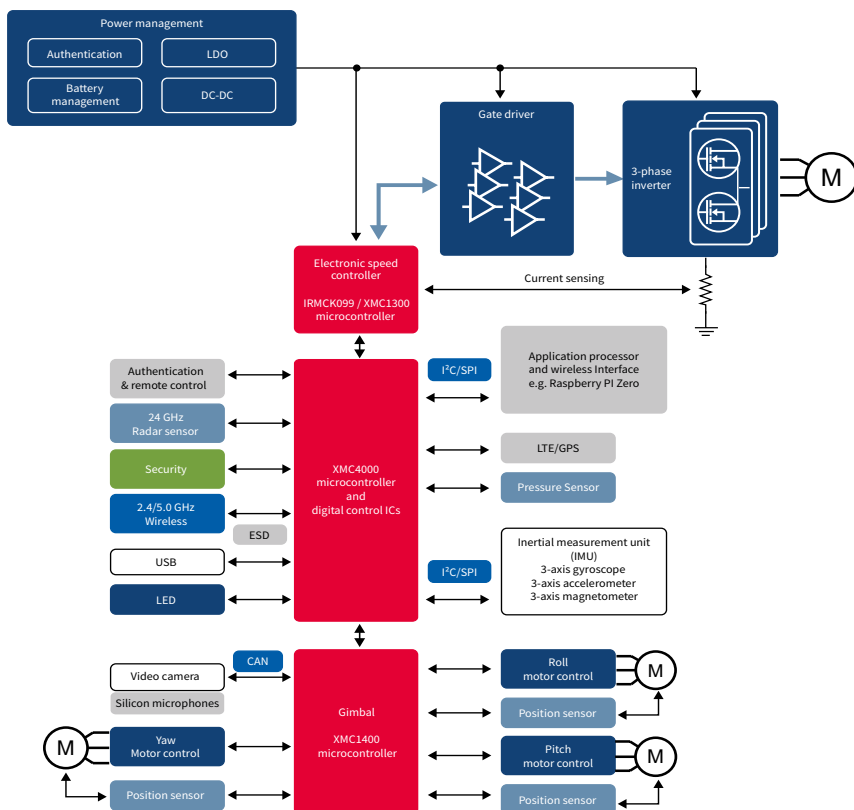

www.infineon.com/multicopter

Benefits	Offer
Development effort and cost reduction	<ul style="list-style-type: none"> > With no or little experience in motor control, customers can implement the iMOTION™ motor control IC and take flight > Project development can be reduced up to 30 percent by using reference designs and the DAVE™ platform for microcontroller programming
Authentication	<ul style="list-style-type: none"> > Infineon's solutions enable authentication of components connected to the system > Guaranteed safety and protection of the product, avoiding liability
Ease-of-precision control for flight and data	<ul style="list-style-type: none"> > Through the benefits of multifunction sensors, the user can experience an easy, stable, smooth and accurate control of the multicopter > Closed loop control of gimbal motor, sensors enhanced camera stability and data transmission when recording video
Longer flight times	<ul style="list-style-type: none"> > The highly efficient components and effective flight control can make the multicopter lighter, which results in longer flight time
Collision avoidance	<ul style="list-style-type: none"> > XENSIV™ 24 GHz radar sensors have the capability of detecting the proximity of objects such as trees, buildings, etc.
Altitude stabilization	<ul style="list-style-type: none"> > The miniaturized digital barometric air pressure sensors based on capacitive technology guarantee high precision during temperature changes
Broader portfolio	<ul style="list-style-type: none"> > Infineon can provide all the necessary critical semiconductor components for multicopters
Fast time-to-market	<ul style="list-style-type: none"> > A complete eco-system of simulations, documentation and demoboard solutions enables a faster time-to-market

Infineon offers a comprehensive portfolio to address a broad range of multicopters.

Find more information at www.infineon.com/multicopter

Solution tree for multicopters

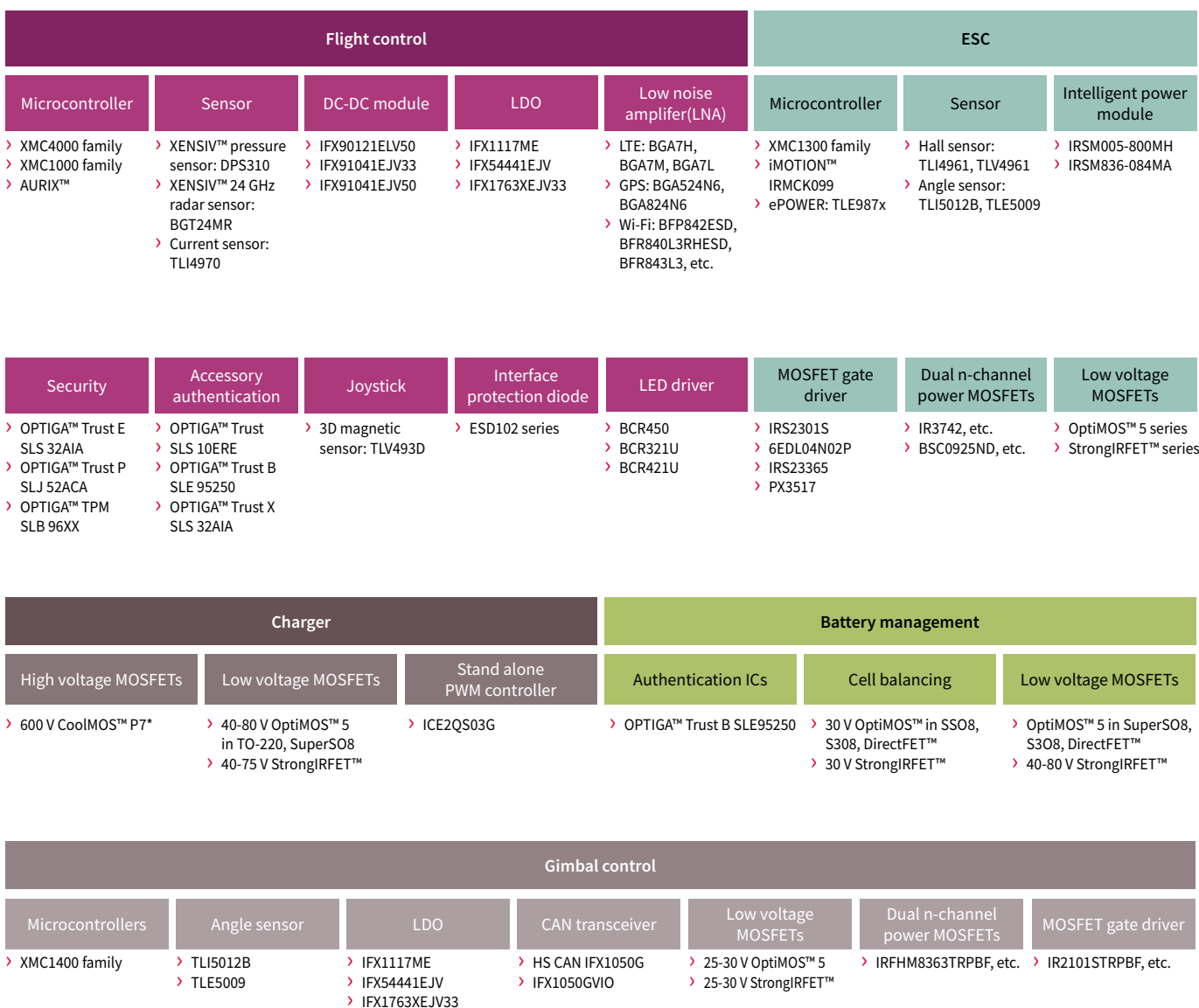

www.infineon.com/multicopter

* If the necessary package/R_{DS(on)} combination is not available in the new CoolMOS™ P7 series yet, the previous CoolMOS™ CE and P6 series are the preferred series



Smart home

Smartifying homes the secured way

How does a smart home differ from a regular home? A smart home is equipped with technologies that make our lives more convenient and energy efficient. Today, the growing range of technologies encompasses smart home appliances, mobile devices and home automation systems, many of which are interconnected. But being 'smart' in this sense requires appliances and systems fitted with the right semiconductor solutions. They empower smart appliances, devices and systems to make sense of their environment and current situation. Working together, sensors, controllers and actuators enable members of a smart home to properly collect, interpret and process real-time data, then trigger the appropriate action or response. In an age of mounting security threats, security solutions keep all activities and system secured and out of harm's way.

From intelligent lighting control to optimized energy consumption, each smart home function depends on intelligent semiconductors. As this rapidly changing field continues to evolve and mature, having a reputable and reliable partner in smart home semiconductor technologies such as Infineon makes all the difference.

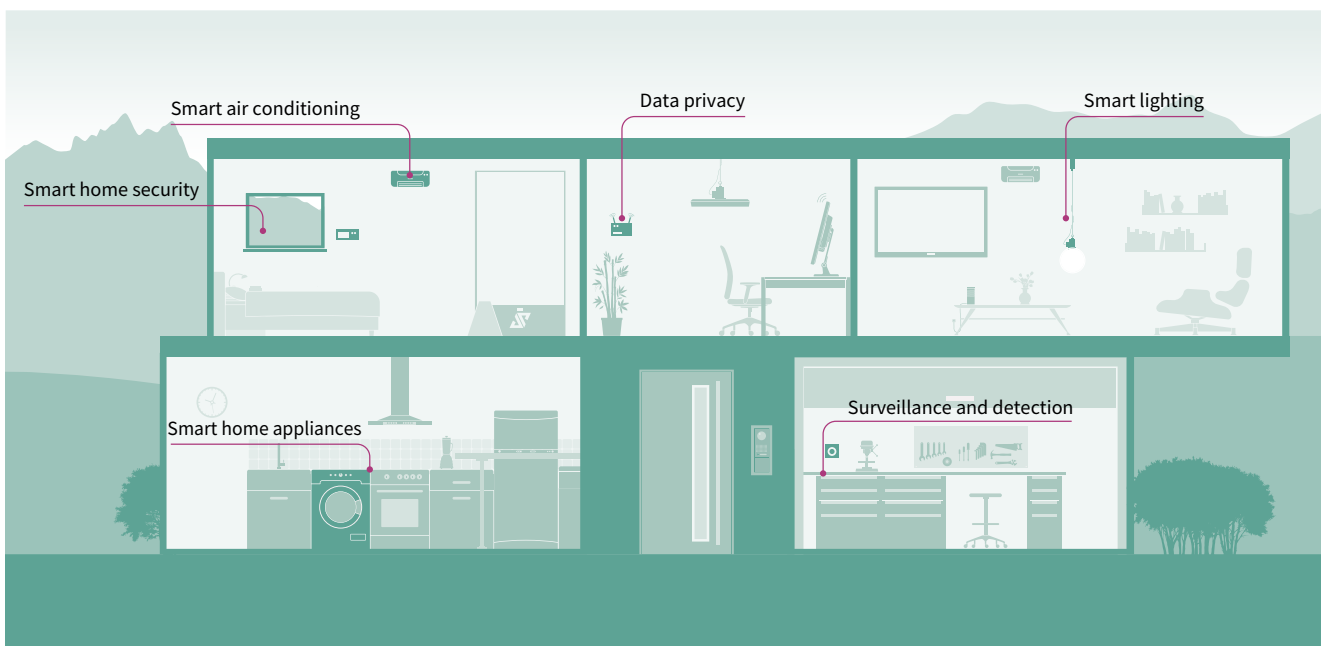

Benefit from our smart home expertise

Unparalleled system knowledge

Our in-depth system know-how coupled with our market expertise means you get application specific solutions that are best in class

Lasting reliability

With a proven track record, our high-quality products help keep our customers' business uncertainty at a minimum.

Easy-to-integrate solutions

We enable you to reduce your time-to-market thanks to easy-to-integrate products and a strong global support team for your designs.





www.infineon.com/smarthome



Infineon's leading portfolio of best-fit, ready-to-use semiconductor solutions empowers you to create innovative smart home applications that meet both current and future demands. You can count on our components to be smart, secured and energy efficient. In our one-stop shop, you will find all components and solutions required for your project. Furthermore, our products are easy to integrate into your designs.

As you forge new, unexplored territory in the smart home realm, our in-depth know-how of our components and their potential in smart homes and home automation systems enable us to support you through and through. At the cutting-edge of key smart home technologies, we are in the position to guide you through this exciting new market while you explore new opportunities and business models. Especially those new to smart homes will appreciate our easy-to-use smart home demo and our basic offering of solutions.

How Infineon's offering enhances your project

<p>Advanced sensing </p> <p>Contextual sensitivity with market-leading accuracy and reliability. For more natural, seamless interaction between humans, machines and the surroundings.</p>	<p>Trusted security </p> <p>The right, easy to implement security solutions for smart, always secured homes. We meet your design's evolving security needs without compromising on convenience.</p>	<p>Cross-application control </p> <p>Ensure optimized system performance thanks to our deep system understanding and strong processing and steering know-how. The result: an excellent user experience.</p>	<p>Efficient power management </p> <p>Our innovative power electronics technologies allow users to save energy and run applications at a market-leading low energy level. It's the basis for real green smart homes.</p>
--	---	---	--

www.infineon.com/smarthome



Enabling secured communication for IoT

OPTIGA™ Trust product family

An increasingly connected world enables new services and features leading to new business models. For these services, high system reliability and data integrity are key necessities. The Internet of Things generates an increased amount of data due to the proliferation of sensors and actuators that have become available at an attractive cost.

Intelligent lighting systems represent one of the leading applications that enable collection of information that goes beyond pure lighting functionality. Lighting systems manufacturers are looking into implementing new functions to their customers such as:

- › advanced presence detection including people counting
- › sound detection
- › pressure and environmental sensing

Collection and processing of that data targets to increase customer value in smart buildings and smart cities. Proliferation of interconnected nodes poses serious challenge in terms of ensuring that the IoT does not offer backdoors to cybercrimes. Infineon offers several products that build an “anchor of trust” in order to ensure secure data communication with the OPTIGA™ Trust product family. In a connected world, the performance and security of the smart IoT systems can be continuously improved by firmware updates. As an example, a radar system that fulfills a presence detection function in office meeting rooms might be enhanced by software update to count people in meeting rooms in order to optimize the usage of assets, in this case meeting rooms. The implementation of this firmware update in a secure manner is fundamental. The update may need to be authenticated to verify its source and the authenticity of the file or may be sent encrypted to protect the know how included in the update. To do so and prevent unauthorized firmware updates, these can be sent with a cryptographic signature as encrypted files allowing the receiving system to verify and decrypt the update before installing it. With Infineon’s OPTIGA™ Trust product family, the keys used for the signature and encryption are stored in the hardware-based OPTIGA™ security solution, and therefore cannot be easily read out or altered.

Application flow for secure software update

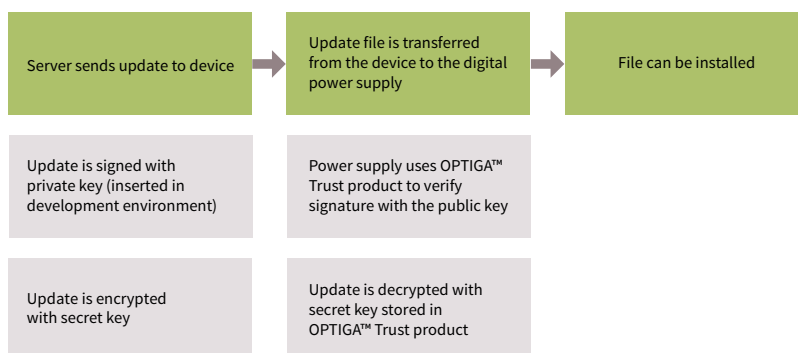

Key benefits of OPTIGA™ security

Combining state-of-the-art hardware security controllers with software

- › Reliable turnkey products with a proven track record
- › Strong security based on the latest cryptography
- › Offering a variety of interfaces to match your system architecture
- › Easy to integrate based on evaluation kits, host code and reference applets
- › Developed and manufactured in certified environment

www.infineon.com/optiga

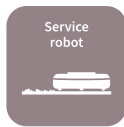

Robotics

Superior solutions for industrial and service robotics

Disruptive technologies have significantly changed our lifestyle in the past few decades. Now a new era is on the horizon – the age of robots. Robots are joining the ranks of innovative and disruptive technologies by revolutionizing traditional habits and processes. Today’s robots are able to identify and navigate their surroundings, work alongside and even interact with humans and they teach themselves the skills required to complete a new task.

All this would not be possible without semiconductor solutions. Whether in an industrial robot, a cobot, an automated guided vehicle (AGV) or a service robot, intelligent semiconductors are the key enabler for all major robotic functions. Drawing on our insight into all facets of the robotics field, and with a comprehensive portfolio of power products and sensors on offer, we are able to provide reliable system solutions that address the latest trends in robotics like artificial intelligence, the Internet of Things, smart home, cloud based services, human machine interface etc., and add value to nearly every robot design.

Industrial robots – achieve greater productivity and optimize costs

Structural system overview: industrial robot

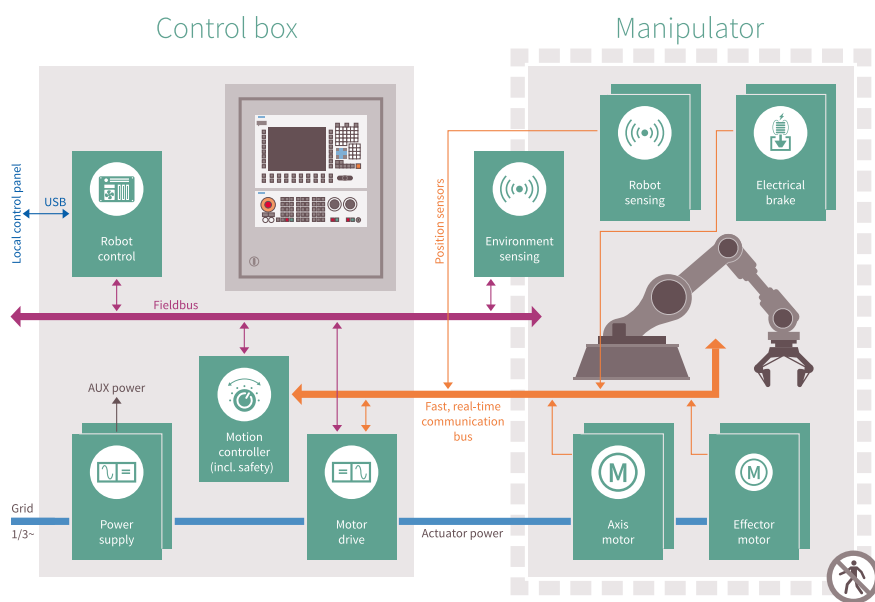

In the era of Industry 4.0 and smart factories, the latest generation of industrial robots is revolutionizing traditional manufacturing processes, thus creating the benefits for manufactures worldwide, such as increased productivity and enhanced cost optimization. Regardless of the robot’s size, number of axes and payload, Infineon’s wide product portfolio has the right solution for nearly any industrial robot design.

Cobots – advance through collaboration

Cobots, or collaborative robots, work outside the limitation of a safety cell, in a direct interaction with real people. This setup requires a precise set of design features, especially for the sake of workplace safety. With Infineon’s semiconductors for cobot systems, you benefit from the expertise of an experienced and reliable partner. Our radar and sensor solutions, for example, provide the tools to uphold even the highest safety standards and allow the robots to leave their formerly fenced working environment.

www.infineon.com/robotics

www.infineon.com/industrial-robotics

Automated guided vehicles – driving production and logistics forward

Structural system overview: battery-powered AGV

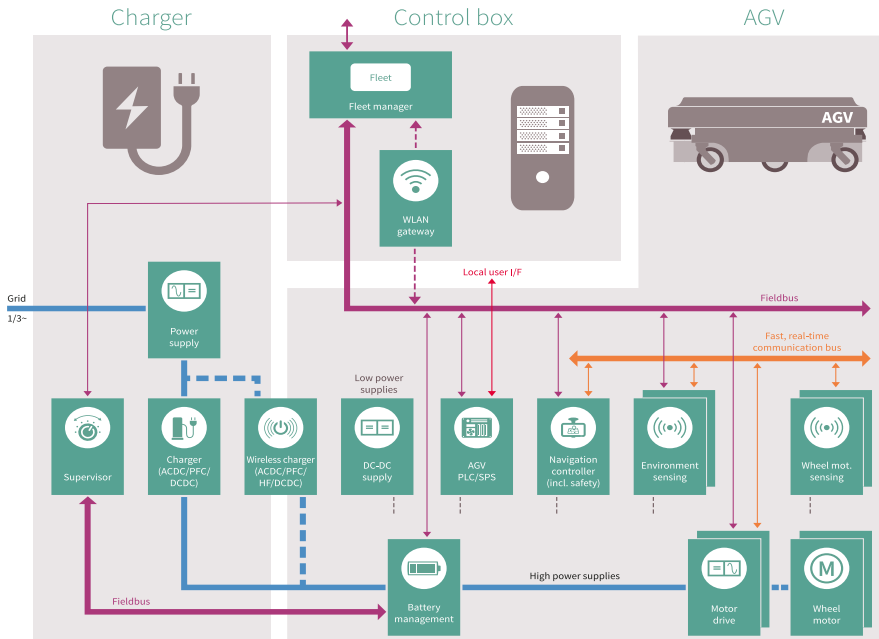

Automated guided vehicles (AGVs) are a self-driving force behind automated manufacturing processes. Battery-powered systems offer the highest degree of flexibility within working environment. Covering the entire product portfolio of robotics applications – from the power supply to motor drives and sensors for navigation and environment scanning – Infineon is equipped to ensure AGVs can find their way through nearly all production environments.

Service robots - simplifying everyday life and work

Structural system overview: service robot

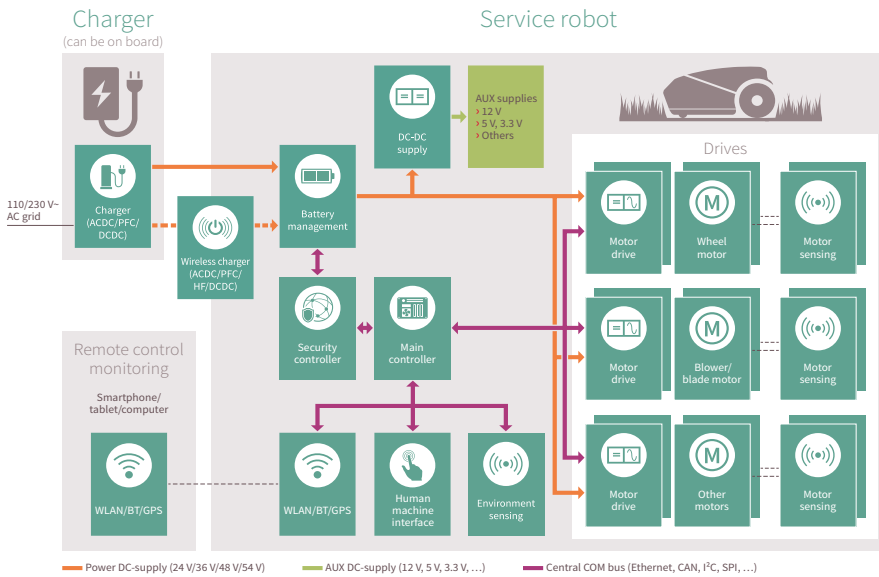

The latest generation of service robots is ushering in a new level of assistance and simplicity in homes and professional environments. They directly interact with humans, which introduces unique challenges from a design perspective, especially in domestic environments. Energy efficiency and long battery life as well as security aspects and sensing capabilities are key to user-friendly and safe designs. By choosing Infineon, you get a one-stop semiconductor shop for all your service robot design needs.

How our offering enhances your project

At Infineon you will find ready-to-use semiconductor solutions out of one hand. Our well-thought-out products, combined with our deep know-how and proven experience, enable you to take your robotics project to the next level. By providing everything from reliable chargers and efficient power plus battery management, to compact motor control and indispensable sensors, to unrivalled hardware-based security solutions, our portfolio of leading semiconductor solutions covers everything you need to leverage the full potential of any robotic system.

www.infineon.com/robotics

www.infineon.com/service-robotics

Infineon's key enabling products for robotics

Functional block	Purpose	Characteristics	Component Type or Family
Power: -Power supply -Power factor correction (PFC) -Charger -Battery management	Power switches (0.4-6 kW output power)	25-150 V	OptiMOS™
		20-75 V	StrongIRFET™
		P-/N-channel -60 to 20 V	Small signal MOSFETs
		600-800 V	CoolMOS™ P7
		600 V	CoolMOS™ C7
		600 V	CoolMOS™ CFD7
		600 V	CoolGaN™
		600 V	IGBT HighSpeed 5
	PFC power diodes	650 V Schottky diode	CoolSiC™
	Integrated power stage	800 V	CoolSET™
	Gate driver ICs	12-100 V	IRS2000x
		12-1200 V, non-isolated	EiceDRIVER™ 1EDN/2EDN
		12-1200 V, functional/safe isolation	EiceDRIVER™ 1EDI/2ED/2EDF/2EDS
		12-1200 V, three-phase	EiceDRIVER™ 6ED, 6EDL
	Microcontroller	ARM® Cortex®-M0 microcontroller	XMC1100/XMC1300
		ARM® Cortex®-M4 microcontroller	XMC4200
Voltage regulators	LDO and DCDC switching regulators	e.g. IFX1763, IFX90121	
Battery authentication	Hardware-based, embedded security	OPTIGA™ Trust B	
Motor control	Motor inverter power switches	<12 V, <400 W	PROFET™
		20-60 V	StrongIRFET™
		60 V	SIPMOS™
		25-100 V, <1kW	OptiMOS™
		P-/N-channel MOSFETs ranging from -60 V to 20 V	Small signal MOSFETs
		600 V, <500 W	CoolMOS™ CFD7
		650 V, <500 W	CoolMOS™ CFD2
		600/1200 V, <10 kW	TRENCHSTOP™
		1200 V, 10-20 kW	CoolSiC™
		Fully integrated, 600 V, 0.5-5 kW	CIPOS™
		Fully integrated, 600 V, <20 kW	EasyPIM™
		Fully integrated, 1200 V, 10-20 kW	CoolSiC™ Easy1B
	Gate driver ICs	12-100 V	IRS2000x
		12-1200 V, non-isolated	EiceDRIVER™ 1EDN/2EDN
		12-1200 V, functional/safe isolation	EiceDRIVER™ 1EDI/2ED/2EDF/2EDS
		12-1200 V, three-phase	EiceDRIVER™ 6ED, 6EDL
		Integrated gate driver ICs	NovalithIC™
		Automotive embedded power ICs	TLE986x, TLE987x
	Microcontroller	ARM® Cortex®-M0 microcontroller	XMC1000 microcontroller family
		ARM® Cortex®-M4 microcontroller	XMC4000 microcontroller family
		TriCore™ Safety certified security on-chip	AURIX™
		Fully integrated motor control ICs	iMOTION™
	Position & condition sensing	XENSIV™ magnetic Hall switches	TLx496x
		XENSIV™ angle sensor, digital I/F	TLE/TLI5012B, TLE5014SP
		XENSIV™ angle sensor, analog I/F	TLE5009/5109/5309/5501
		XENSIV™ 3D magnetic sensor, digital I/F	TLV/TLE/TLI493D
		XENSIV™ current sensor, digital I/F	TLI 4970
		XENSIV™ current sensor, analog I/F	TLI4971
	Object & condition sensing	XENSIV™ pressure/temperature sensor, digital I/F	DPS310
		XENSIV™ 24 GHz radar	BGT24MTR11/12, BGT24MR2
		XENSIV™ MEMS microphone, analog I/F	IM69D120/IM69D130
		XENSIV™ ToF 3D imaging @ 38-100k pixel	REAL3™ IRS1125C/IRS1645C/IRS2381C
Sensing: -Robot sensing -Environment sensing -Human machine interface			
Peripherals: -WLAN/BT/GPS -Human machine interface	Audio	Class D audio amplifier	IR43x1M, IR43x2M
	Interface	CAN, CAN FD, CAN PD @ 1-5 MBit/s	Industrial CAN transceiver
		Industrial interface ICs	ISOFACE™
	LED drivers	Driving currents from 10-250 mA	Linear driver ICs BCR3xx, BCR4xx
		Support currents from 150 mA to 3A	DCDC switch mode ILD4xxx, ILD6xxx
	Security and safety -Motion controller (incl. safety) -Security controller	Controller	TriCore™ Safety certified with security on-chip
Sensors		Safe angle sensing - dual die structure	e.g. TLE5009xxxD
Voltage regulators		DCDC voltage regulator 12 V/ 5V or 3.3 V; watchdog, error monitoring, safe state control, BIST etc.	e.g. TLF35584
Security		Hardware-based, embedded security solutions, mutual authentication, secure communication, key protection, data signing etc.	OPTIGA™ TPM/Trust B/Trust X

For the complete portfolio, visit our website.

www.infineon.com/robotics



SMPS

Right-fit portfolio for competitive design of laptop adapters

Manufacturing slimmer and lighter adapters requires ICs enabling high efficiency with good electromagnetic interference (EMI) performance and low standby power. There is also a need for cost-effective MOSFETs in small packages that feature good EMI and excellent thermal performance. Infineon offers a wide range of products specifically designed for adapters including high voltage MOSFETs and control ICs for PFC and PWM stages, as well as low voltage MOSFETs for synchronous rectification. With these products, Infineon supports the trend towards a significantly higher efficiency level, especially in partial load conditions, as well as miniaturization of the adapter.

Extremely versatile are the recently released CoolMOS™ P7 SJ MOSFET series series, which combine high efficiency and optimized cost with the ease of use. Infineon developed a family of packages, characterized by having a short lead, IPAK Short Lead with ISO-Standoff and wide creepage that enable our customers' cheap and reliable manufacturing, specifically for adapters. High power density at low manufacturing cost can be delivered using Infineon's SOT-223 cost-effective package which enables SMT manufacturing, while maintaining very good thermal performances. For synchronous rectification, Infineon's OptiMOS™ power MOSFET series offer extremely low on-state resistance and low capacitances.

New control ICs support topologies such as quasi-resonant flyback, and digital-based XDP controller can enable the forced frequency resonant flyback (zero voltage switching) operation, making it ideal to implement in high power density adapters and supporting USB-PD requirements.

Regional regulations and a general increased sensitivity toward the containment of electronic waste are pointing toward the adoption of universal adapters. The implementations, methodologies and protocols are not yet harmonized; however, Infineon is already closely monitoring and partnering with the decision makers to timely ensure the offer of a competitive semiconductor solution. The capability to efficiently manage different power classes and protocols are key in this application, and Infineon is getting ready to support adapter makers in this challenge.

Functional block	Product category	Topology	Product family	Benefits
Flyback converter	High voltage MOSFETs and HEMTs	Flyback	600 V/700 V/800 V CoolMOS™ P7 SJ MOSFETs	<ul style="list-style-type: none"> Fast-switching speed for improved efficiency and thermals Reduced gate charge for enhanced light load efficiency Optimized gate-to-source voltage (V_{GS}) threshold for lower turn-off losses
		Flyback (ACF, FFR, etc.)	CoolGaN™ 600 V e-mode HEMTs	<ul style="list-style-type: none"> Highest efficiency Highest power density
	Low voltage MOSFETs	Flyback/auxiliary synchronous rectification	OptiMOS™ 100-150 V	<ul style="list-style-type: none"> Low conduction losses and reduced overshoot Logic level can support low voltage gate drive to achieve high efficiency
	Control ICs	QR flyback IC	ICE2QS03G, ICE5QSAG	High efficiency and low standby power
		FFR flyback IC	IDP2105, XDPS21061	High power density and digital control
PFC	High voltage MOSFETs, HEMTs, and diodes	DCM PFC	600 V CoolMOS™ P7 SJ MOSFETs	<ul style="list-style-type: none"> Fast-switching speed for improved efficiency Reduced gate charge for enhanced light load efficiency Optimized gate-to-source voltage (V_{GS}) threshold for lower turn-off losses
		DCM/CCM PFC	CoolGaN™ 600 V e-mode HEMTs	<ul style="list-style-type: none"> Highest efficiency contribution via less parasitic parameter Space saving with SMD smaller package
	Boost diode	DCM/PFC	650 V Rapid 1 diodes	Low conduction losses
	Control ICs	DCM PFC ICs	TDA4863G, IRS2505LTRPBF	<ul style="list-style-type: none"> Simple external circuitry High power factor and low THD
Main stage	High voltage MOSFETs and HEMTs	HB LLC	600 V CoolMOS™ P7 SJ MOSFETs	<ul style="list-style-type: none"> Fast-switching speed for improved efficiency and thermals Reduced gate charge for enhanced light load efficiency Optimized gate-to-source voltage (V_{GS}) threshold for lower turn-off losses
			CoolGaN™ 600 V e-mode HEMTs	<ul style="list-style-type: none"> Highest efficiency Highest power density
Synchronous rectification	Low voltage MOSFETs	Synchronous rectification	OptiMOS™ 5 100-150 V	<ul style="list-style-type: none"> Low conduction losses, reduced overshoot Logic level switching
	Control ICs	Synchronous rectification	IR1161LTRPBF	<ul style="list-style-type: none"> High efficiency Simple external circuitry

www.infineon.com/smps

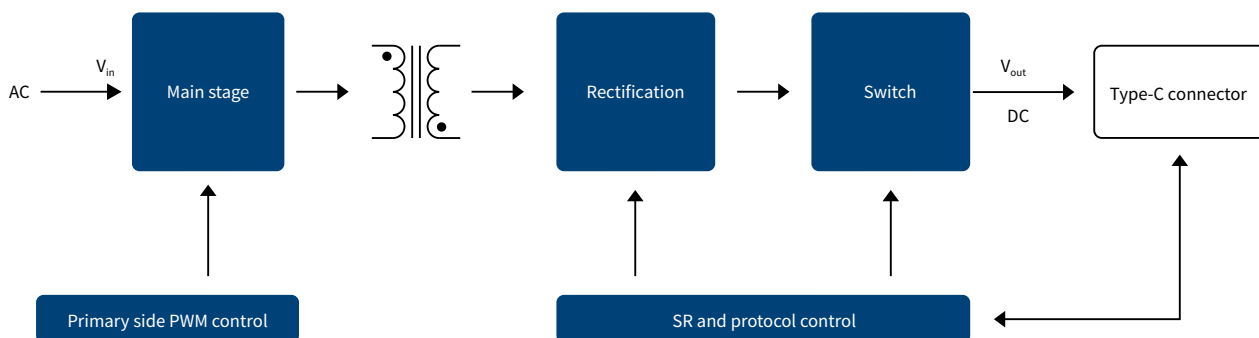

Travelling with multiple and often clunky chargers and adapters for phones, tablets and laptops has been a nuisance for many consumers, and often leads to frustrations due to the additional weight and required space. Over the past years manufacturers of chargers and adapters became increasingly aware of these issues and a trend towards higher power density and consequently smaller devices has emerged. Today, the typical power topology used in such systems is a flyback power conversion topology and the form factor is limited by the efficiency achievable at 90 V_{AC} input voltage and full load. The highest power density systems available today reach ~12 W/in³ (for 65 W maximum output power). Infineon's CoolGaN™ e-mode HEMTs enable a breakthrough with respect to power density for adapter and charger systems enabling ~20 W/in³ power density systems (for 65 W maximum output power). This advantage can be realized by implementing Infineon's CoolGaN™ in a half-bridge topology that allows increasing switching frequency and efficiency simultaneously.

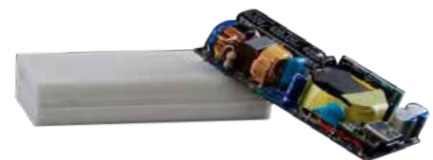

Infineon's 20 W/in³ adapter (cased) - 24 W/in³ (uncased) with 65 W output power capability (LxWxH: 74.2 mm x 36.5 mm x 16.5 mm)

www.infineon.com/smps

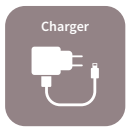

SMPS

Best solutions for mobile charger

Modern mobile devices require a charger that provides faster charging but comes in a small size. High power density and cost-effective power supplies can be designed by operating the converter at a higher switching frequency to avoid a considerable increase in the transformer and the output capacitor size. In achieving the required thermal performance and EMI behavior, power devices with lower losses and controlled switching behavior enable effective and fast product development.

Infineon’s state-of-the-art digital-based controller XDPS21061 enables the forced frequency resonant flyback (zero voltage switching) operation, ideal to implement in high power density adapters and well-supporting USB-PD requirements.

To address these requirements, Infineon offers its CoolMOS™ P7 SJ MOSFET family for adapters and chargers. Special care has been taken to ensure very good thermal behavior, increased efficiency and fulfillment of all EMI requirements, enabling our customers to easily design products based on this new family. In addition, power devices in IPAK/SMD packages enable optimal PCB layout through minimal footprint. SMD packages offer additional benefits for automatized large volume production. Specifically, high power density at low manufacturing cost can be delivered using Infineon’s SOT-223 cost-effective package, which enables SMT manufacturing maintaining very good thermal performances.

The digital soft switching controller, CoolMOS™ high voltage MOSFETs, OptiMOS™ low voltage MOSFETs and synchronous rectification IC portfolios, enable high power density designs whilst meeting the thermal requirements.

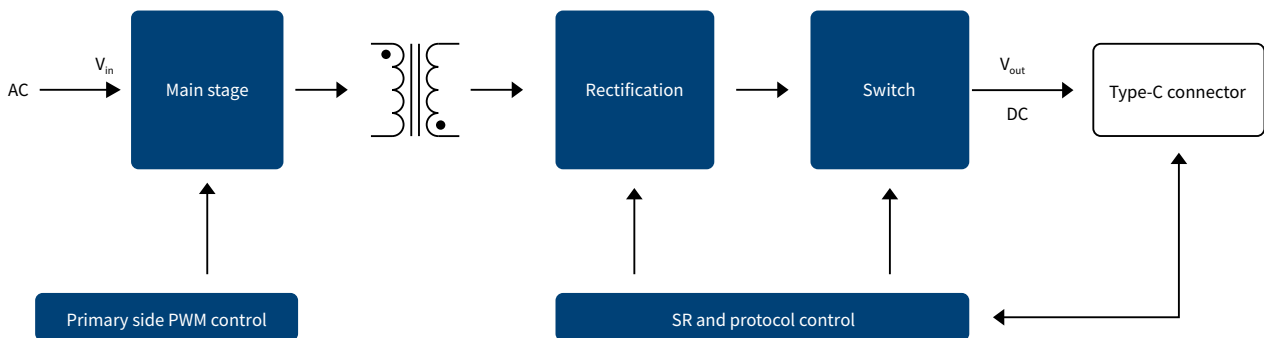

Functional block	Product category	Topology	Product family	Benefits
Flyback converter	High voltage MOSFETs	Flyback	700 V CoolMOS™ P7 (standard grade)	<ul style="list-style-type: none"> Best price competitive CoolMOS™ SJ MOSFET family Lower switching losses versus standard MOSFET
	Control ICs	QR flyback ICs	ICE5QSAG , ICE5QSAG	<ul style="list-style-type: none"> High efficiency and low standby power
		FFR flyback IC	XDPS21061	<ul style="list-style-type: none"> High power density and ideal for USB-PD
Synchronous rectification	Low voltage MOSFETs	Synchronous rectification	OptiMOS™ 5 40-120 V logic level	<ul style="list-style-type: none"> Low conduction losses and reduced overshoot Logic level switching S308/PQFN 3.3 x 3.3 package available
	Control ICs	Synchronous rectification	IR1161LTRPBF	<ul style="list-style-type: none"> High efficiency Simple external circuitry
Load switch	Low voltage MOSFETs	Load switch	OptiMOS™ 30 V	<ul style="list-style-type: none"> Low conduction losses S308/PQFN 3.3 x 3.3 package available

www.infineon.com/smps



SMPS

More efficient PC power supply

The PC power market is divided into high-end gaming PC and better cost-performance sectors to achieve a better price performance goal for desktop SMPS. The PC OEMs are implementing the desktop SMPS by removing the AUX power block, to save the cost of having a flyback circuit.

Infineon's IDP2321 is the first digital PFC + LLC combo IC worldwide to meet world-leading PC manufacturers' specifications, with integrated drivers and a 600 V depletion cell to achieve low standby power and lower cost. The PFC controlling loop is a configurable CrCM/DCM multimode to meet highest light-load efficiency. And the most important of all, IDP2321 has approximately 30 to 40 less part counts than traditional analog solutions, thanks to the state-of-the-art digital control.

Furthermore, Infineon's IDP2321 offers flexible IC parameter configuration with user-friendly GUI, which means R&D engineers can key in the parameters on the PC to fine-tune and debug the system performance instead of soldering the passive components. Infineon offers the best total system solutions for non-AUX PC power together with its SMD and through-hole MOSFETs.

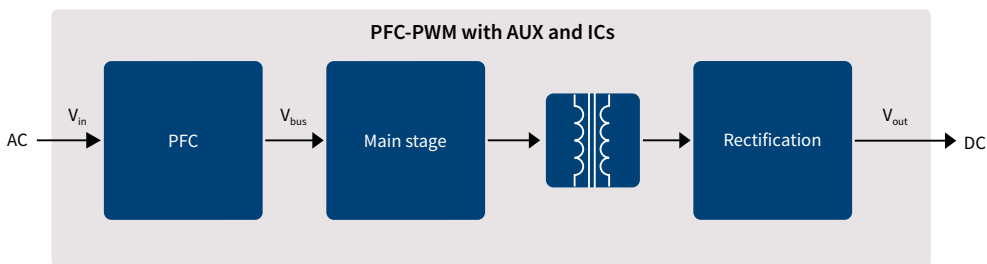

Functional block	Product category	Topology	Technology	Benefits
PFC/Main stage	High voltage MOSFETs	CrCM/DCM PFC	600 V CoolMOS™ P7	<ul style="list-style-type: none"> > Best thermal performance > Rugged body diode > ESD enhancement for production line > Wide $R_{DS(on)}$ portfolio including both THD and SMD packages
			600 V CoolMOS™ P6	<ul style="list-style-type: none"> > Fast-switching speed for improved efficiency and thermals > Low gate charge for enhanced light-load efficiency and low power consumption at no load condition > Optimized V_{GS} threshold for low turn-off losses
			500 V CoolMOS™ CE	<ul style="list-style-type: none"> > Optimized cost/performance > Lower transition losses versus standard MOSFET
	Boost diodes	DCM PFC	650 V Rapid 1	> Low conduction losses
		CCM PFC	650 V Rapid 2	> Low reverse recovery losses and PFC switch turn-on losses
Control ICs	CCM PFC ICs	ICE3PCS0xG	> High PFC and low THD	
Main stage	Control ICs	HB LLC ICs	650 V – ICE1HS01G-1/ ICE2HS01G	> High efficiency and low EMI
Synchronous rectification	Medium voltage diodes	HB LLC + center-tap	OptiMOS™ 40 V	> Optimized cost/performance and low thermals
			OptiMOS™ 60 V	> Layout tolerance and low thermals



SMPS

Diversify TV power supply with cost, performance and ease of use

In addition to their outstanding image quality, new generation TVs gain attention for their user interface, low power consumption and for their slim design. This requires the power supply unit (PSU) to either keep a low profile to maintain the slim appearance of a TV and a low thermal dissipation image or to have an external adapter. In addition, a growing number of TV manufacturers will use external adapters to deliver DC power to the TV. Infineon introduced two products based on digital power technology, designed to meet challenging efficiency and standby power requirements for Internet of Things (IoT) enabled TVs (both embedded PSU and adapter).

Thanks to digital power, our customers can reduce the number of TV power supplies by adapting the digital IC parameters to different TV and screen models by flexible and easy parameter setting. On top of that, Infineon recently introduced the digital based flyback controllers, ideal to implement low power adapters for TVs and monitors. With the digital soft switching, the adapter power density can be improved significantly. The new 600 V CoolMOS™ P7 is the logical successor of the current 600 V CoolMOS™ P6. The series has been developed to cover a broad spectrum of different applications where the excellent performance and perfect ease of use are required. The rugged body diode enables not only the use in hard switching topologies, such as power factor correction, boost, and two transistor forward, but also in resonant topologies such as LLC where the technologies lead to high efficiency in both hard-switching and resonant circuits.

For higher on-state resistance ($R_{DS(on)}$) classes, there is a new feature of an integrated ESD diode that helps improve the quality in manufacturing. At the same time, the low $R_{DS(on)}$ and gate charge (Q_g) enable high efficiency in the various topologies. The 600 V CoolMOS™ P7 comes with a wide variety of $R_{DS(on)}$ s and packages on consumer grade to make it best suitable for TV power by balancing the cost and performance. Infineon developed specifically for TV power supplies a family of packages, characterized by short lead, SOT-223 mold stopper and wide creepage distance, which enable our customers' cheap and reliable manufacturing.

Functional block	Product category	Topology	Product family	Benefits
Main stage/PFC combo non-AUX	High voltage MOSFETs	DCM PFC, HB LLC	600 V CoolMOS™ P7	<ul style="list-style-type: none"> Fast-switching speed for improved efficiency Low gate charge for enhanced light load efficiency and low power consumption at no load condition Optimized V_{GS} threshold for lower turn-off losses Rugged body diode for HB LLC application
			500 V/600 V CoolMOS™ CE	<ul style="list-style-type: none"> Easy control of switching behavior even in non-optimized layout Lower switching losses in comparison with its predecessor Rugged body diode which prevents device failure during hard commutation
	Control ICs	IDP2308	PFC-LLC non-AUX digital IC for TV embedded PSU	<ul style="list-style-type: none"> Low BOM count/system cost due to high integration Low standby power High system reliability Shorter development cycles and higher design and production flexibility
			IDP2303A	PFC-LLC non-AUX digital IC for TV adapter
PFC	Boost diodes	DCM PFC	650 V Rapid diode	<ul style="list-style-type: none"> Low conduction losses
	Control ICs	CCM PFC ICs	ICE3PCS0xG	<ul style="list-style-type: none"> High PFC and low THD
Main stage	Control ICs	HB LLC ICs	ICE1HS01G-1/ICE2HS01G	<ul style="list-style-type: none"> High efficiency and low EMI
Auxiliary power supply	Control ICs	QR/FF flyback CoolSET™	700 V/800 V – ICE5QRxx70/80A(Z)(G)	<ul style="list-style-type: none"> Low standby power, high efficiency and robustness
Flyback	Control ICs	Digital ZVS flyback	IDP2105	<ul style="list-style-type: none"> Forced resonant ZVS control reduces the switching loss Multilevel protection enables the robust design Flexible firmware provides more differentiation for OEMs
	High voltage MOSFETs	Flyback	700 V CoolMOS™ P7	<ul style="list-style-type: none"> Optimized for flyback topologies Best price competitive CoolMOS™ SJ MOSFET family Lower switching losses versus standard MOSFET Controlled dV/dt and dI/dt for better EMI

www.infineon.com/smps



Non-AUX digital solution for large screen size

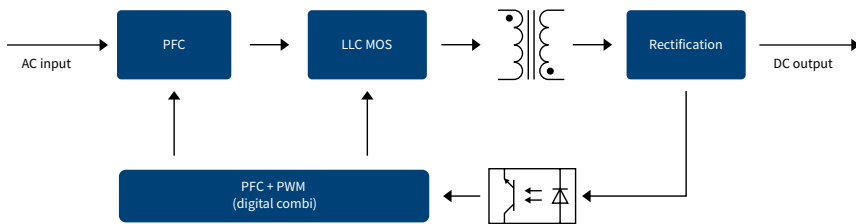

High power solution for larger screen size

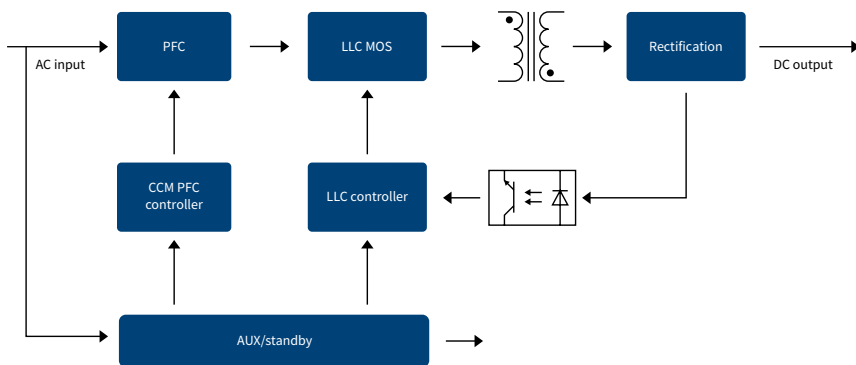

Flyback solution for small screen size

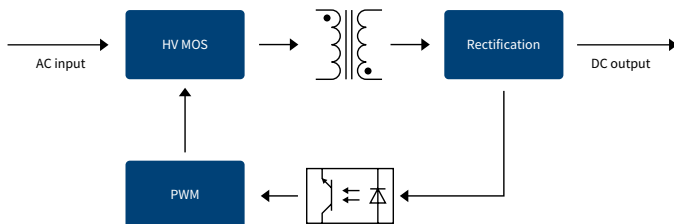

www.infineon.com/smps

OLED TV power block diagram

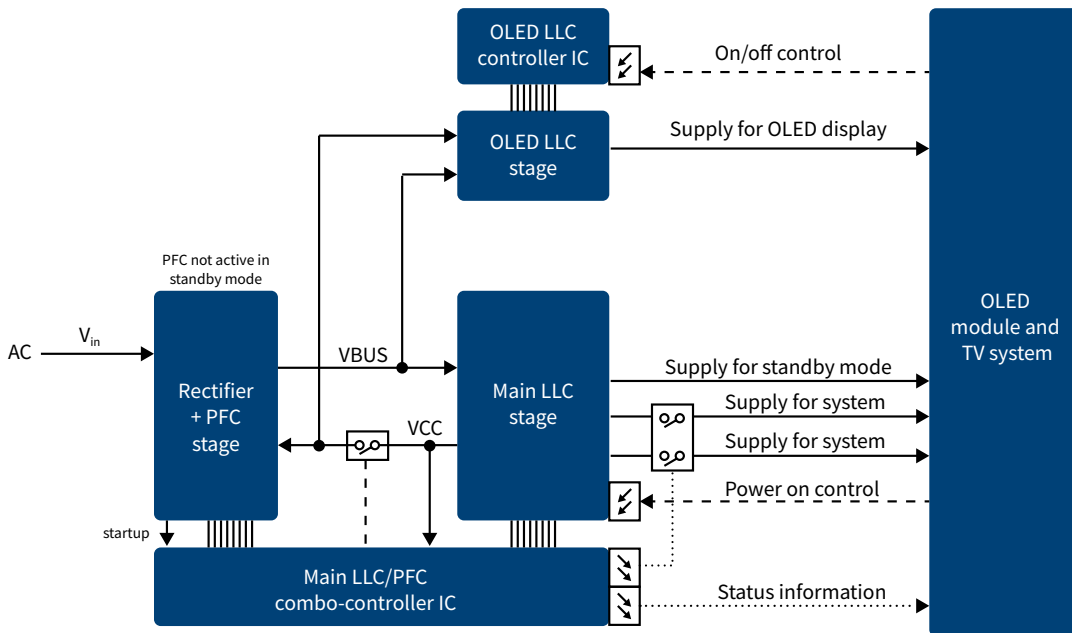

Benefiting from several advantage of organic light emitting diodes (OLED), varying TV manufacturers are developing OLED TVs to level up the user experience of their consumers. Comparing with LCD/LED TV panels, the OLED can be thinner, lighter and more flexible, also the power consumption is lower. With the excellent performance of wide bandgap GaN power MOSFETs from Infineon, the OLED TV become even thinner and more reliable.

CoolGaN™ portfolio

$R_{DS(on)}$	DSO-20-85 Bottom-side cooling	DSO-20-87 Top-side cooling	HSOF-8-3 TO-leadless	LSON-8-1 DFN 8x8
35	IGO60R035D1*	IGOT60R035D1*	IGT60R035D1*	
70	IGO60R070D1	IGOT60R070D1	IGT60R070D1	IGLD60R070D1
190			IGT60R190D1* IGT60R190D1S**	IGLD60R190D1*
340				IGLD60R340D1*



SMPS

Full system solutions for embedded power supplies

Customers who design or manufacture a product that needs embedded intelligence typically want to focus on the system design of their product, be it white goods, a vending machine, an automatic door opener or any other product. They do not want to spend valuable efforts and time in designing the power supply systems. They just want to use them, having a trouble-free, EMI friendly, and reliable power supply.

Infineon decided to build a scalable broad range of products, and flexible, and easy to reuse reference designs aimed at helping its customers with best fitting solutions tailored for their different needs.

Depending on their specific needs, our customers can select very low-cost power supply reference designs featuring high integration or using a platform approach to reuse the same power designs for different products that need different power supplies. If high efficiency is needed, for example to meet ENERGY STAR label requirements or to improve overall thermal performance, Infineon offers highest efficiency power supply reference designs.

In addition, Infineon offers comprehensive reference designs and application notes helping customers to drastically improve the efficiency of their power supply by using secondary-side synchronous rectification instead of a rectifier diode. Benefits of synchronous rectification are better efficiency and better thermal performance of your power supply.

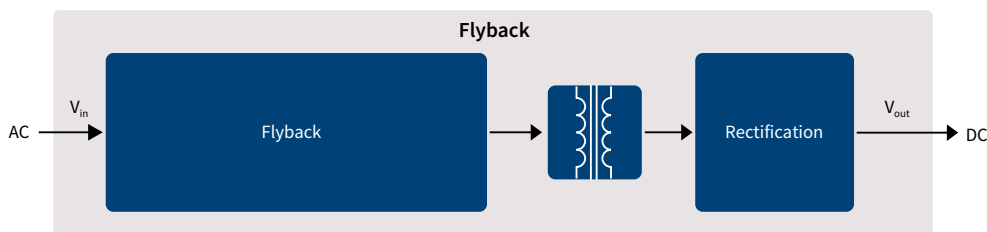

Functional block	Product category	Topology	Technology	Benefits
Auxiliary power supply	Control ICs	QR/FF flyback CoolSET™	700 V/800 V ICE5QRxx70/80A(Z)(G)	<ul style="list-style-type: none"> > Low standby power, high efficiency and robustness
Flyback	Control ICs	QR flyback	ICE5QSAG	<ul style="list-style-type: none"> > High efficiency and low standby power
	High voltage MOSFET	Flyback	700 V/800 V CoolMOS™ P7	<ul style="list-style-type: none"> > Best price competitive CoolMOS™ family > Lower switching losses versus standard MOSFET > Controlled dV/dt and di/dt for better EMI



SMPS

Highly efficient server power supply

The trend in the field of enterprise and data center server is to deliver more power per rack. Meanwhile, the higher rising cost of energy and environmental concerns make SMPS efficiency optimization a key requirement across the entire load range for server and data center design. This challenging task is combined with the requirement for higher power and higher power density with cost-effective design.

In the PFC stage and in general hard-switching topologies used in server applications, Infineon recommends its 600 V CoolMOST™ C7 family with the lowest FOM $R_{DS(on)} * Q_G$ and $R_{DS(on)} * E_{oss}$. This MOSFET series provides the lowest switching losses, which are necessary in fast switching needed in high-end server SMPS. In this way, the efficiency is optimized starting from a very light-load operation. The very compact SMD packages such as ThinPAK, DPAK and TOLL offer benefits in space and power density and are used with Infineon's new industry standard non-isolated driver family 2EDN752x. Complementary to the 600 V CoolMOST™ C7 in high efficiency PFC is the CoolSiC™ Schottky diode generation family. The 600 V CoolMOST™ P6 family offers a good compromise between price and performance. This is valuable in both PFC and HV DC-DC stages where the low Q_G and turn-off losses are important benefits, especially in the case of high-switching frequency operation and high light load efficiency requirements. In applications which require very high efficiency (Titanium and above) and power density, 650 V CoolMOST™ G7 and 600 V CoolGaN™ families enable the highest efficiency and power density at lower system cost for high power (2~3 kW above). Operating expenses (OPEX) and capital expenditures (CAPEX) are both reduced through simplified topologies and the power density in server PSU is doubled.

In applications with a low output voltage and a high output current, further efficiency improvements have been made possible by the continuous reduction of on-resistance by Infineon's low voltage OptiMOS™ MOSFET series used in the synchronous rectification stage. Infineon's low voltage families are complemented by StrongIRFET™ which is optimized for lower switching frequencies and highest system robustness.

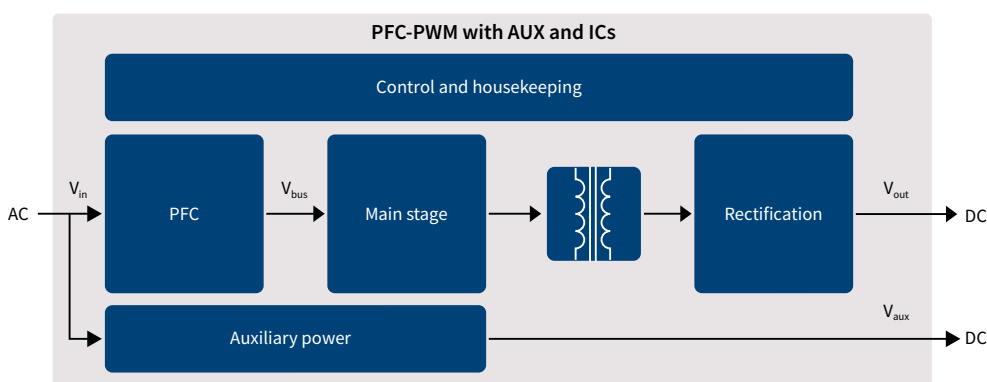

Functional block	Product category	Topology	Product family	Benefits
PFC	High voltage MOSFETs	CCM/interleaved PFC; TTF	600 V/650 V CoolMOS™ C7 650 V CoolMOS™ G7	<ul style="list-style-type: none"> › Best FOM $R_{DS(on)} \cdot Q_G$ and $R_{DS(on)} \cdot E_{oss}$ › Lowest $R_{DS(on)}$ per package › Low dependency of switching losses from $R_{g,ext}$
	High voltage GaN	Totem pole PFC	600 V CoolGaN™	› Enable the highest efficiency and highest power density
	SiC diodes	CCM/interleaved PFC	650 V CoolSiC™ Schottky diode generation 5	› Low FOM $V_f \cdot Q_G$
	Control ICs	CCM PFC ICs	ICE3PCS0xG	› Ease of use
Main stage	High voltage MOSFETs	ITTF	600 V CoolMOS™ C7/P6	<ul style="list-style-type: none"> › Fast switching speed for improved efficiency and thermals › Low gate charge for enhanced light load efficiency and low power consumption at no load condition › Optimized V_{GS} threshold for lower turn-off losses › Rugged body diode which prevents device failure during hard commutation
		LLC, half-bridge below 1 kW	600 V CoolMOS™ P7, CFD7	<ul style="list-style-type: none"> › Low turn-off losses › Low Q_{oss} › Low Q_G
		LLC, phase shift full-bridge below 1 kW	600 V CoolMOS™ CFD7, 650 V CoolMOS™ CFD2	<ul style="list-style-type: none"> › Fast and rugged body diode › Optimized low Q_G and soft commutation behavior to reach highest efficiency › Highest reliability for 650 V V_{DS}
		ZVS PS FB; LLC, TTF	650 V TRENCHSTOP™ F5	› Improved ruggedness and high efficiency in low inductance designs
	Control ICs	HB LLC ICs	ICE1HS01G-1 ICE2HS01G	› High efficiency and low EMI
Synchronous rectification	Low voltage MOSFETs	HB LLC and center tap	OptiMOS™ power MOSFET 40 V	› High efficiency over whole load range, layout tolerance
		ITTF	60 V OptiMOS™	› High efficiency, low thermals, low V_{DS} overshoot
		ZVS PS FB and center tap	80 V OptiMOS™	› High efficiency over whole load range, low V_{DS} overshoot and oscillations
Auxiliary power supply	Control ICs	QR/FF flyback CoolSET™	800 V – ICE2QRxx80(Z)(G) ICE3xRxx80J(Z)(G) 700 V ICE5QRxx70A(Z)(G) 800 V ICE5QRxx80A(Z)(G)	<ul style="list-style-type: none"> › Low standby power, high efficiency and robustness › An integrated 700 V/800 V superjunction power MOSFET with avalanche capability › Burst mode entry/exit to optimize standby power at different low load conditions
Housekeeping	Microcontrollers	-	XMC1xxx	<ul style="list-style-type: none"> › Flexibility, HR PWM, digital communication › ARM® based standard MCU family and wide family
Conversion	Microcontrollers	-	XMC4xxx	› Flexibility, HR PWM and digital communication
PFC, PWM/resonant converter, synchronous rectification	Gate driver ICs	-	1EDix EiceDRIVER™	<ul style="list-style-type: none"> › 100 ns typical propagation delay time › Functional isolation › Separate source
		-	2EDNx EiceDRIVER™	<ul style="list-style-type: none"> › 8 V UVLO option › -10 V input robustness › Output robust against reverse current



SMPS

Full system solution for telecom power supply

The telecommunication industry providing data, voice, and video services is continuously growing supported by the expansion into new markets and accelerated by the spread of wireless and broadband technologies. The outstanding improvements in telecom SMPS performance made in the past 10 years have been primarily brought about by the dramatic reduction of the on-resistance achieved in high voltage MOSFETs, using the revolutionary superjunction principle. This principle was introduced by Infineon at the end of the nineties with the CoolMOS™ series.

Equally impressive improvements in reverse-recovery characteristics have been achieved for high voltage CoolSiC™ (silicon carbide) diodes. Infineon’s high voltage (HV) offerings are complemented by the newly introduced HV GaN switches – the CoolGaN™ family, which enables highest electrical conversion efficiency at attractive system costs. In order to meet the new challenging efficiency targets, the synchronous rectification utilizing the unique performance of OptiMOS™ low voltage MOSFETs has become increasingly popular even in the typically high output voltage of telecom rectifiers.

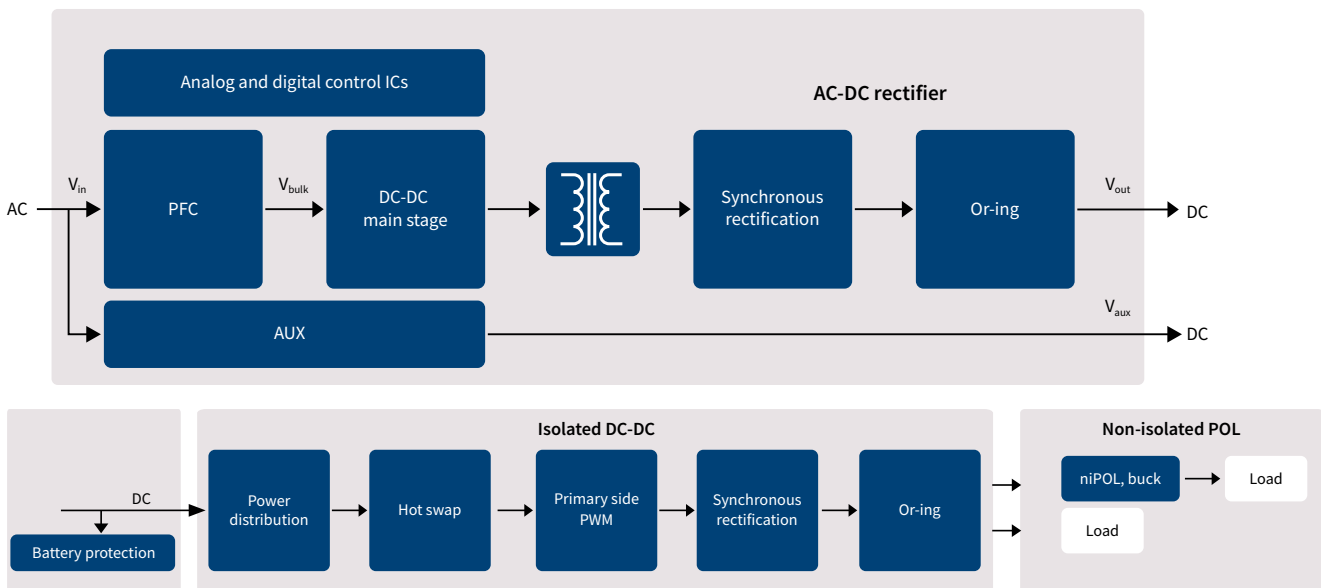

Functional block	Product category	Topology	Product family	Benefits
PFC	High voltage MOSFETs	CCM/interleaved PFC; TTF	600 V/650 V CoolMOS™ C7	<ul style="list-style-type: none"> > Best FOM $R_{DS(on)} \cdot Q_G$ and $R_{DS(on)} \cdot E_{oss}$ > Lowest $R_{DS(on)}$ per package > Low dependency of switching losses from $R_{g,ext}$
			600 V CoolMOS™ P7	<ul style="list-style-type: none"> > Low turn-off losses > Low Q_{oss} > Low Q_G
	High voltage GaN	CCM totem pole	CoolGaN™ 600 V	<ul style="list-style-type: none"> > Switching at high frequencies (> Si) > Enables high power density
	SiC diodes	CCM/interleaved PFC	650 V CoolSiC™ Schottky diode generation 6	> Low FOM $V_f \cdot Q_C$
	Control ICs	CCM PFC ICs	800 V – ICE3PCS0xG	> High PFC and low THD
	GaN driver ICs	Totem pole PFC	EiceDRIVER™ 1EDF5673F and 1EDF5673K	<ul style="list-style-type: none"> > Low driving impedance (on-resistance 0.85 Ω source, 0.35 Ω sink) > Input-output propagation delay accuracy: ±5 ns > Functional and reinforced isolation available

Functional block	Product category	Topology	Product family	Benefits
DC-DC main stage	High voltage MOSFETs	CCM/interleaved PFC; TTF HB LLC	600 V CoolMOS™ C7/P7	<ul style="list-style-type: none"> Fast-switching speed for improved efficiency and thermals Low gate charge for enhanced light load efficiency and low power consumption at no load condition Optimized V_{GS} threshold for lower turn-off losses Rugged body diode which prevents device failure during hard commutation
		LLC	600 V CoolMOS™ P7	<ul style="list-style-type: none"> Low turn-off losses Low Q_{oss} Low Q_G
		CCM/interleaved PFC; TTF HB LLC	600 V CoolMOS™ CFD7	<ul style="list-style-type: none"> Best-in-class Q_n and t_{tr} level Significantly reduced Q_G Improved efficiency over previous CoolMOS™ fast body diode series
	Control ICs	HB LLC ICs	ICE1HS01G-1, ICE2HS01G	<ul style="list-style-type: none"> High efficiency and low EMI
	GaN driver ICs	LLC, ZVS phase shift full-bridge	EiceDRIVER™ 1EDS5663H	<ul style="list-style-type: none"> Low driving impedance (on-resistance 0.85 Ω source, 0.35 Ω sink) Input-output propagation delay accuracy: +/- 5 ns Functional and reinforced isolation available
	GaN e-mode HEMTs	LLC, ZVS phase shift full-bridge	CoolGaN™ 600 V	<ul style="list-style-type: none"> Enable the highest efficiency and highest power density
Synchronous rectification	Low voltage MOSFETs	Synchronous rectification MOSFET	OptiMOS™ 80-150 V	<ul style="list-style-type: none"> Industry's lowest FOM ($R_{DS(on)} * Q_G$) leading to high efficiency at good price/performance Low voltage overshoots enabling easy design-in Industry's lowest $R_{DS(on)}$ Highest system efficiency and power density Outstanding quality and reliability Reduces the need for a snubber circuit
Auxiliary power supply	Control ICs	5 th generation QR/FF flyback CoolSET™	QR 800 V - ICE5QRxx80Ax FF 800 V - ICE5xRxx80AG	<ul style="list-style-type: none"> Quasi-resonant switching operation for high efficiency and low EMI signature Fixed frequency switching operation for ease of design – 100 KHz and 125 KHz Fast and robust start-up with cascode configuration Robust protection with adjustable line input over-voltage protection, V_{CC} and CS pin short-to-ground protection Optimized light-load efficiency with selectable burst mode entry/exit profile Frequency reduction for mid- and light-load condition to reduce switching losses and increase efficiency Direct feedback and regulation with integrated error amplifier for non-isolated output High power delivery of up to 42 W with 800 V CoolSET™ in heatsink-free SMD package
Housekeeping	Microcontrollers	-	XMC1xxx	<ul style="list-style-type: none"> Flexibility, HR PWM, digital communication ARM® based standard MCU family and wide family
Conversion	Microcontrollers	-	XMC4xxx	<ul style="list-style-type: none"> Flexibility, HR PWM, digital communication ARM® based standard MCU family and wide family
PFC, PWM/resonant converter, synchronous rectification	Gate driver ICs	Single-channel non-isolated	EiceDRIVER™ 1EDN751x	<ul style="list-style-type: none"> 8 V UVLO option (-)10 V input robustness Output robust against reverse current
		Single-channel non-isolated	EiceDRIVER™ 1EDN7550	<ul style="list-style-type: none"> 8 V UVLO option (-)10 V input robustness True differential inputs for >100 V_{AC} ground shift robustness
		Dual-channel non-isolated	EiceDRIVER™ 2EDN7x	<ul style="list-style-type: none"> 8 V UVLO option (-)10 V input robustness Output robust against reverse current
		Dual-channel junction isolated	EiceDRIVER™ 2EDL811x*	<ul style="list-style-type: none"> 20 ns typical propagation delay time 20 V bootstrap capability on high side (-)7 V input robustness
		Single-channel isolated	EiceDRIVER™ 1EDi Compact	<ul style="list-style-type: none"> 100 ns typical propagation delay time Functional isolation 1.2 kV separate source and sync outputs
		Dual-channel isolated	EiceDRIVER™ 2EDFx	<ul style="list-style-type: none"> 35 ns typical propagation delay time Functional isolation 1.5 kV CMTI > 150 V/ns
		Dual-channel isolated	EiceDRIVER™ 2EDSx	<ul style="list-style-type: none"> 35 ns typical propagation delay time Reinforced (safe) isolation 6 kV CMTI > 150 V/ns
Or-ing	Low voltage MOSFETs	Or-ing MOSFET	OptiMOS™ 60-200 V	<ul style="list-style-type: none"> Industry's lowest FOM ($R_{DS(on)} * Q_G$) leading to high efficiency at good price/performance Low voltage overshoots enabling easy design-in
Battery protection	Low voltage MOSFETs	MOSFET	OptiMOS™ 60-150 V	
Isolated DC-DC	Low voltage MOSFETs	Primary side PWM MOSFET	OptiMOS™ 60-200 V	<ul style="list-style-type: none"> Industry's lowest $R_{DS(on)}$ Highest system efficiency and power density Outstanding quality and reliability Reduces the need for a snubber circuit
			StrongIRFET™ 60-200 V	
			Small signal MOSFETs 60-200 V	
		Synchronous rectification MOSFET	OptiMOS™ 40-100 V	
			StrongIRFET™ 40-100 V	
		Or-ing MOSFET	OptiMOS™ 25-30 V	
StrongIRFET™ 25-30 V				



Fast EV Charging

Advanced solutions for DC EV charging

What speaks for off-board DC EV charging?

With the growing number of electric vehicles (EVs), which are in some markets becoming viable alternatives to traditional internal combustion engine vehicles, the demand for enhanced semiconductor solutions for charging stations increases too. Currently, all eyes are on China where EVs have gained traction in the rapidly expanding middle class, while Europe and the United States are expected to follow suit soon. However, to truly welcome EVs on a large scale, these markets need to provide widespread availability of DC charging infrastructure so that drivers can quickly charge their vehicles. DC charging systems are an attractive choice because they offer much faster charging than a standard AC EV charger which many EV drivers possess. Today a DC charger with e.g. 150 kW can put a 200 km charge on an EV battery in just 15 minutes. The improvement of charging technologies is expected to even further lower the charging time. Consequently, off-board charging is becoming more and more attractive.

Challenges on the horizon

Reaching the next level in designing DC EV chargers confronts engineers with many new challenges.

For a DC charging design to be a long term success, you must:

- > Enhance output power to shorten the charging time
- > Improve power density within the set dimensions of the charging station
- > Increase efficiency by boosting the load and decreasing power dissipation
- > Reduce design cost per watt

Overcoming all of the mentioned issues is possible – with the right partner.

The right partner for successful DC EV charger designs

As a market leader and the global frontrunner in power electronics, Infineon enables you to bring energy-efficient DC EV charger designs to life, with our highly efficient components and in-depth technical support. We cover power ranges from kilowatt to megawatt in our broad portfolio of high-quality power semiconductors, microcontrollers, gate drivers and security, safety, and authentication solutions. Our CoolMOS™ and CoolSiC™ MOSFETs, for example, are ideal in a wide range of DC EV charging designs. Their matchless advantages include high frequency operation, high power density and reduced switching losses, allowing you to reach high levels of efficiency in any battery charging system.

System diagram DC EV charger

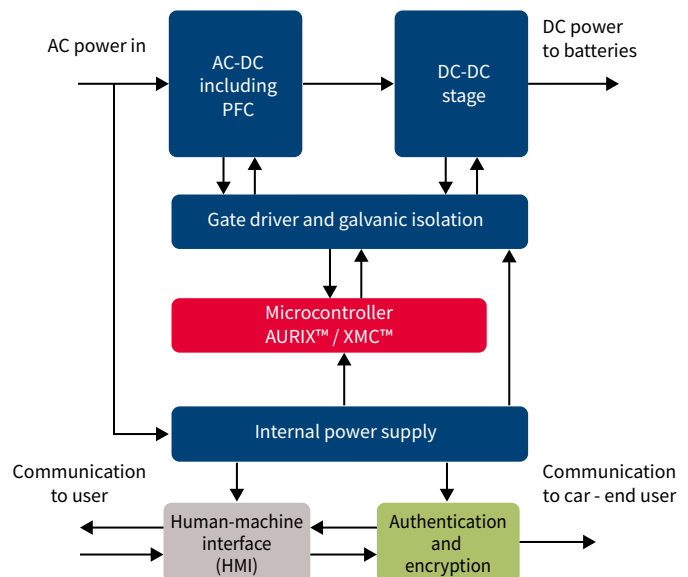
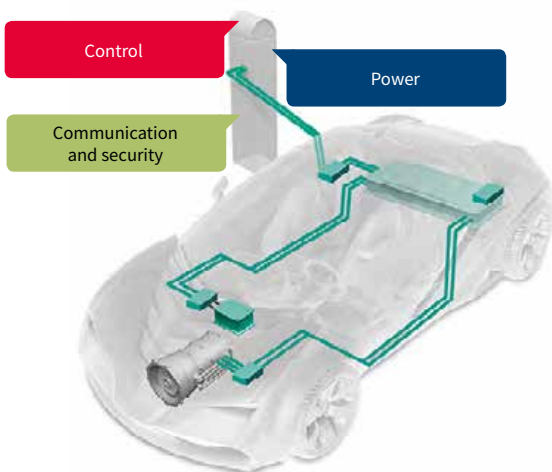

www.infineon.com/ev-charging

Through extensive interaction with DC EV charging designers and being a member of CharIN, we have vast system expertise in electric mobility as well as its automotive safety and data security. All this contributes to making vehicle chargers safe, efficient, and fast. Based on that knowledge, Infineon provides a comprehensive offering addressing application needs of DC EV charging:

- › Power semiconductor and gate driver solutions for highly efficient power conversion
- › Authentication solutions for secure authentication and protection against misuse
- › Encryption solutions ensuring secure communication for billing and roaming

Infineon’s solution recommendation for DC EV charging system blocks

Our solutions are designed for harsh environmental conditions and long life time as we have an excellent understanding of quality requirements. Take the next step by exploring our product portfolio for DC EV charging systems.

PFC stage (three-phase input)

Product category	Product family	Product	Additional information
High voltage MOSFET / SiC MOSFET / IGBT	650 V CoolMOS™ C7	IPW65R019C7	650 V, 19 mΩ, TO-247
	600 V CoolMOS™ C7	IPW60R017C7	600 V, 17 mΩ, TO-247
	600 V CoolMOS™ P7	IPW60R024P7	600 V, 24 mΩ, TO-247
		IPW60R037P7	600 V, 37 mΩ, TO-247
		IPW60R060P7	600 V, 60 mΩ, TO-247
		650 V TRENCHSTOP™ 5 H5	IKW50N65EH5/IKZ50N65EH5
		IKW75N65EH5/IKZ75N65EH5	650 V, 75 A, TO-247-3/4
	1200 V CoolSiC™ MOSFETs	IMW120R045M1/IMZ120R045M1	1200 V, 45 mΩ, TO-247-3/4
	1200 V CoolSiC™ Easy modules	F3L15MR12W2M1_B69	1200 V, 15 mΩ, Easy 2B, Vienna rectifier phase leg
		FS45MR12W1M1_B11	1200 V, 45 mΩ, Easy 1B, sixpack
SiC diodes	1200 V CoolSiC™ Schottky diodes generation 5	IDW15G120C5B/IDWD15G120C5	1200 V, 15 A, TO-247-3/2
		IDW20G120C5B/IDWD20G120C5	1200 V, 20 A, TO-247-3/2
		IDW30G120C5B/IDWD30G120C5	1200 V, 30 A, TO-247-3/2

HV DC-DC main stage

Product category	Product family	Product	Additional information		
High voltage MOSFET / SiC MOSFET	600 V CoolMOS™ CFD7 / CSFD	IPW60R018CFD7	600 V, 18 mΩ, TO-247		
		IPW60R024CFD7	600 V, 24 mΩ, TO-247		
		IPW60R037CSFD	600 V, 37 mΩ, TO-247		
		IPW60R040CFD7	600 V, 40 mΩ, TO-247		
		IPW60R055CFD7	600 V, 55 mΩ, TO-247		
		IPW60R070CFD7	600 V, 70 mΩ, TO-247		
		600 V CoolMOS™ C7	IPW65R045C7	650 V, 45 mΩ, TO-247	
		600 V CoolMOS™ P7	IPW60R080P7	600 V, 80 mΩ, TO-247	
		1200 V CoolSiC™ SiC MOSFET	IMW120R045M1/IMZ120R045M1	1200 V, 45 mΩ, TO-247-3/4	
		1200 V CoolSiC™ Easy module	FF6MR12W2M1_B11	1200 V, 6 mΩ, Easy 2B, half-bridge	
	FF8MR12W2M1_B11		1200 V, 8 mΩ, Easy 2B, half-bridge		
	FF11MR12W1M1_B11		1200 V, 11 mΩ, Easy 1B, half-bridge		
	FF23MR12W1M1_B11		1200 V, 23 mΩ, Easy 1B, half-bridge		
	F4-23MR12W1M1_B11		1200 V, 23 mΩ, Easy 1B, fourpack		
	FS45MR12W1M1_B11		1200 V, 45 mΩ, Easy 1B, sixpack		
	SiC Diodes Output rectification diodes		1200 V CoolSiC™ Schottky diode generation 5	IDW15G120C5B/IDWD15G120C5	1200 V, 15 A, TO-247-3/2
				IDW20G120C5B/IDWD20G120C5	1200 V, 20 A, TO-247-3/2
				IDW30G120C5B/IDWD30G120C5	1200 V, 30 A, TO-247-3/2
			650 V CoolSiC™ Schottky diode generation 5	IDW12G65C5	650 V, 12 A, TO-247
		IDW16G65C5		650 V, 16 A, TO-247	
IDW20G65C5		650 V, 20 A, TO-247			
IDW20G65C5B		650 V, 10 A, TO-247			
IDW24G65C5B		650 V, 24 A, TO-247			
IDW30G65C5		650 V, 30 A, TO-247			
IDW32G65C5B		650 V, 32 A, TO-247			
IDW40G65C5	650 V, 40 A, TO-247				
IDW40G65C5B	650 V, 40 A, TO-247				
IDH20G65C6	650 V, 20 A, TO-220				
650 V CoolSiC™ Schottky diode generation 6	IDH16G65C6	650 V, 16 A, TO-220 real 2-pin			
	IDH12G65C6	650 V, 12 A, TO-220 real 2-pin			
	IDH10G65C6	650 V, 10 A, TO-220 real 2-pin			
	IDH08G65C6	650 V, 8 A, TO-220 real 2-pin			
	IDH06G65C6	650 V, 6 A, TO-220 real 2-pin			
	IDH04G65C6	650 V, 4 A, TO-220 real 2-pin			
	IDDD20G65C6	650 V, 20 A, Double DPAK			
	IDDD16G65C6	650 V, 16 A, Double DPAK			
	IDDD12G65C6	650 V, 12 A, Double DPAK			
	IDDD10G65C6	650 V, 10 A, Double DPAK			
IDDD08G65C6	650 V, 8 A, Double DPAK				
IDDD06G65C6	650 V, 6 A, Double DPAK				
IDDD04G65C6	650 V, 4 A, Double DPAK				

www.infineon.com/ev-charging

Gate driver and galvanic isolation

Product category	Product family	Product	Additional information
Gate driver ICS	EiceDRIVER™ (non-isolated)	1EDN family, 2EDN family	Single-channel/dual-channel, non-isolated low-side gate driver ICS
	EiceDRIVER™ 500-700 V level shift gate driver	IR2214SS	1200 V half-bridge gate driver for IGBTs and MOSFETs with level-shift technology
	EiceDRIVER™ (galvanic isolation)	2EDF7175F, 2EDF7275F	Dual-channel functional isolated (1,5 kV)
		2EDS8265H, 2EDS8165H	Dual-channel reinforced (safe) isolated (6 kV)
		1EDI40I12AF/H, 1EDI60I12AF/H, 1EDC40I12AH, 1EDC60I12AH	600 V / 650 V single-channel, galvanic isolated driver with separate source and sink outputs to drive CoolMOS™ SJ MOSFETs in floating mode as in Vienna rectifier variants
		1EDC20H12AH, 1EDC60H12AH, 1ED020I12-F2, 2ED020I12-F2	1200 V, single-channel/dual-channel, galvanic isolated driver recommended to drive CoolSiC™ MOSFETs and CoolSiC™ EasyPack™ power modules
1EDI30I12MF/H, 1EDC30I12H, 1EDI10I12MF/H, 1EDC10I12MH	1200 V, single-channel, galvanic isolated driver with integrated Miller clamp to drive TRENCHSTOP™ 5 H5 IGBTs		

Microcontroller

Product category	Product family	Product	Additional information
Microcontroller	XMC™	XMC1400 family (PFC stage)	ARM® Cortex® M0 based microcontroller
		XMC4500/4700 (HV DC-DC/PWM stage)	ARM® Cortex® M4F based microcontroller
	AURIX™	TC26X/TC27X TC36X/TC37X	TriCore™ AURIX™ 32-bit microcontroller HSM (hardware secure module) full EVITA compliance

Internal power supply

Product category	Product family	Product	Additional information
AC-DC power conversion	CoolSET™ 5 QR/FF flyback	ICE5QR0680AG	800 V, 42 W, 710 mΩ, PG-DSO-12
		ICE5AR0680AG	800 V, 42 W, 710 mΩ, PG-DSO-12
	5 th generation PWM controllers and CoolMOS™ P7	ICE5QSAG and IPP80R360P7	800 V, 360 mΩ, TO-220
		ICE5QSAG and IPA95R450P7	950 V, 450 mΩ, TO-220 FP
	CoolMOS™ HV SJ MOSFETs	IPN95R1K2P7	950 V, 450 mΩ, SOT-223
		IPN80R1K4P7	800 V, 1.4 Ω, SOT-223

Authentication and encryption

As embedded systems are increasingly becoming targets of attackers, Infineon offers OPTIGA™ - a turnkey security solution.

Product category	Product family	Product	Additional information
Security	OPTIGA™ Trust B	SLE95250000XTSA1	Assymetric ECC authentication with individual certificate key pair and an extended temperature range of -40 to 110°C
	OPTIGA™ Trust TPM	SLB9670XQ2.0	Fully TCG TPM 2.0 standard compliant module with the SPI interface
	SLC37	SLC37ESA2M0, SLI97CSIFX1M00PE	New class of performance and security cryptocontroller adhering to CC EAL6+ high targeted and EMVCo targeted certifications for payment and eSIM applications





Uninterruptible power supply (UPS)

Attractive solutions for highest efficiency and power density

Today's uninterruptible power supply systems introduce a wide range of challenges. Overcoming them requires an increase in output power, power density and energy efficiency. For all your UPS power supply applications, Infineon's high quality products provide you with complete system level solutions. Equipped with our semiconductors, UPS applications can achieve best-possible power conversion efficiency and cutting-edge power density. The benefits are cost reduction and fewer passive components – regardless of the topology used.

By choosing Infineon's products for UPS applications you get solutions that fulfill the latest market requirements. This includes the trend of modularization of UPS brick units due to scalable power demand from data centers, as well as the topology shift from two-level to three-level to achieve higher efficiency. Our products are suitable for any kind of uninterruptible power supplies in telecom, data center, server or industrial automation environments.

	Offline UPS	Online UPS
MOSFETs	OptiMOS™ and StrongIRFET™ 20-300 V CoolMOS™ SJ MOSFETs 500-950 V	
SiC diodes		CoolSiC™ Schottky diode
IGBTs		TRENCHSTOP™ IGBT6 TRENCHSTOP™ 5 H5
Power module and stack		EasyPACK™
Driver ICs	EiceDRIVER™ 1EDN EiceDRIVER™ 2EDN	EiceDRIVER™ 1ED Compact
Auxiliary power supply		CoolSET™ 650-800 V
Microcontrollers	XMC1300 series	

Offline UPS

Bidirectional UPS power stage

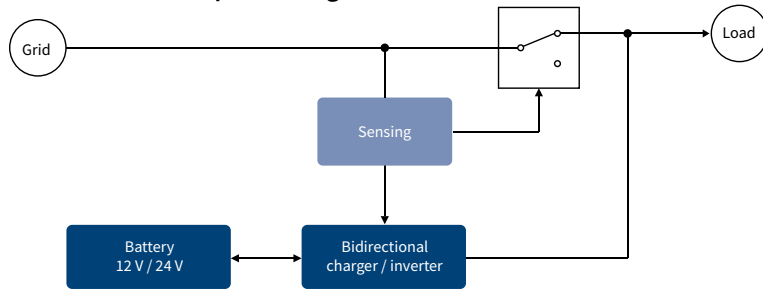

Full-bridge bidirectional power stage

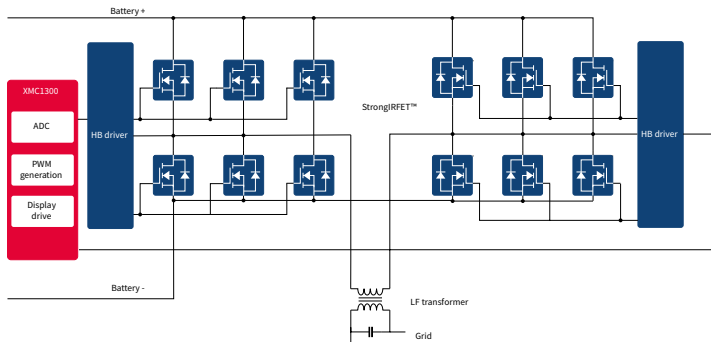

Push-pull bidirectional power stage

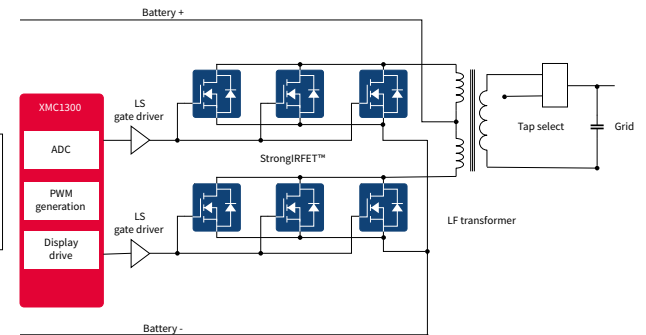

	Battery voltage	Topology	MOSFET breakdown voltage	TO-220	TO-247	D ² PAK and D ² PAK-7	Gate drivers	
Inverter/charger MOSFETs	12 V	Push-pull	60 V	IRFB7530 IRFB7534 IRFB7540 IRFB7545	IRFP3006 IRFP7530 IRFP7537	IRFS7530 IRFS7530-7P	IRS44273 IRS4427 1EDN851X 2EDN852X	
		Full-bridge	30 V 40 V	IRLB3813 IRLB8314 IRLB8743 IRFB7430 (40 V)	IRFP7430	IRFS7430 (40 V) IRFS7430-7P (40 V)	IRS211X IRS2186 2EDL811X	
	24 V	Push-pull	75 V 100 V	IRFB3077 IRFB3207 IRFB7730 IRFB7734	IRFP7718	IRFS7730 IRFS7734 IRF3610S (100 V) IRFS4010 (100 V)	IRS44273 IRS4427 1EDN851X 2EDN852X	
		Full-bridge	40 V 60 V	IRFB7430 IRFB7434 IRFB7545 (60 V) IRF60B217 (60 V)	IRFP7530 IRFP3006 IRFP7537	IRFS7430 IRFS7430-7P IRF7430 IRFS7530-7P	IRS211X IRS2186 2EDL811X	
	48 V	Push-pull	150 V	IRFB4115 IRFB4321 IPP046N15N5 IRFB4228 IRFB4019	IRFP4568 IRFP4321 IRF150P220 IRF150P221	IRFS4321 IRFS4115 RB048N15N5 IRFS4615	IRS44273 IRS4427 1EDN851X 2EDN852X	
		Full-bridge	100 V	IPP030N10N IRFB4110 IPP086N10N3G IRFB4510 IPP180N10N3G	IRFP4468 IRFP4110 IRF100P218 IRF100P219	IRFS3610 IRF3710S IRF8010S IRFS4510 IRFS4010	IRS211X IRS2186 2EDL811X	
	72 V	Push-pull	200 V	IPP110N20N3 IRFB4127 IRFB4227 IPP320N20N3 IRFB4320	IRF200P222 IRFP4668 IRF200P223 IRFP4127 IRFP4227	IPB110N20N3LF IRFS4127 IRFS4227 IRFB117N20NFD IRF200S234	IRS44273 IRS4427 1EDN851X 2EDN852X	
		Full-bridge	150 V	IRFB4321 IPP046N15N5	IRFP4568 IRF150P220	IRFS4321 IRB048N15N5	IRS211X IRS2186 2EDL811X	
		Full-bridge	200 V	IPP110N20N3 IRFB4227	IRF200P222 IRFP4668	IPB110N20N3LF IRFS4127	IRS211X IRS2186 2EDL811X	
	Microcontrollers	12-72 V	XMC1300 series					

Unidirectional

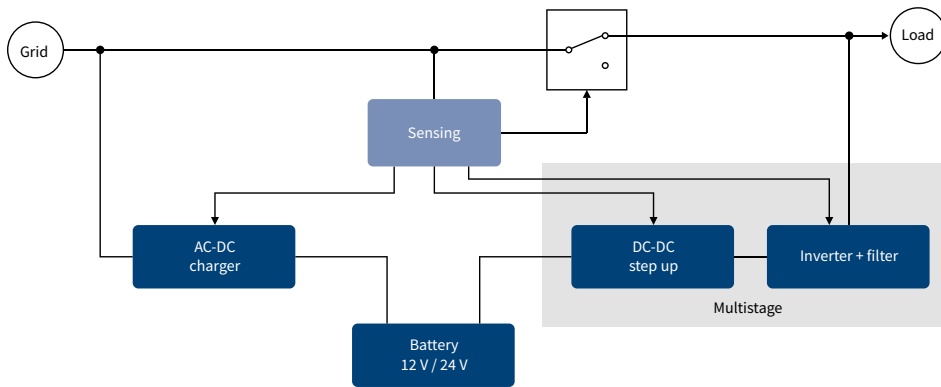

Unidirectional power stage (output stage)

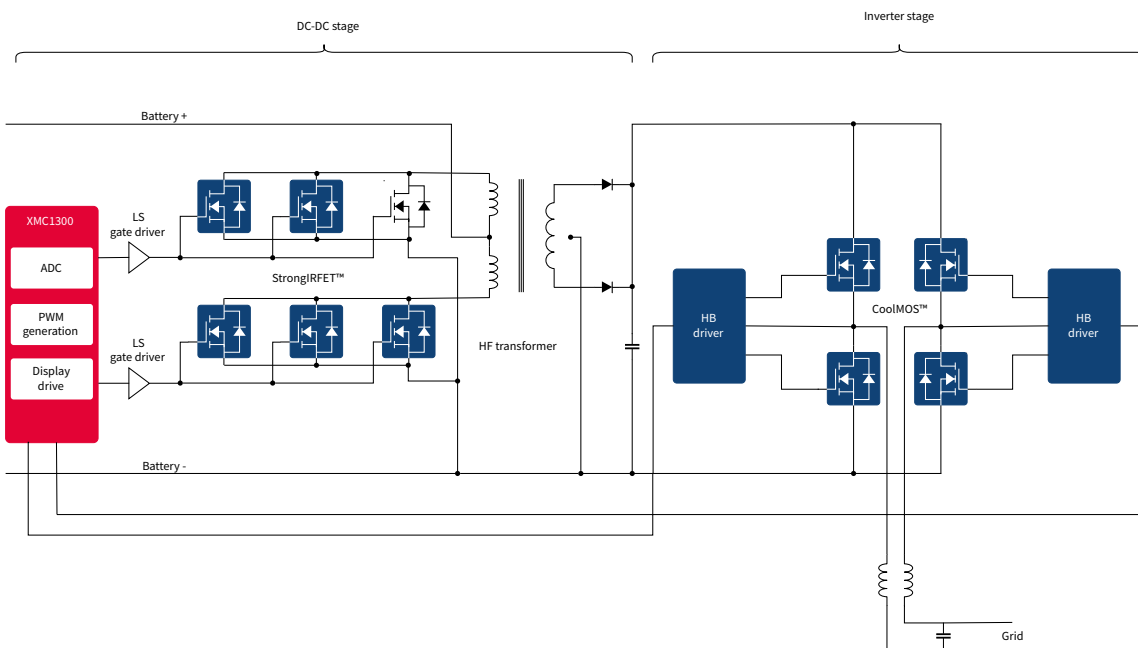

Unidirectional DC-DC stage

Battery voltage	Topology	MOSFET breakdown voltage	TO-220	TO-247	D ² PAK and D ² PAK-7	Gate drivers
12 V	Push-pull	40 V	IRFB7430 IRFB7434	IRFP7718	IRFS7430 IRFS7430-7P IRF7430	IRS44273 IRS4427 1EDN851X 2EDN852X
		60 V	IRFB7540 IRFB7545 IRF60B217		IRFS7530-7P	
		75 V		IRFP7718		
24 V	Push-pull	75 V	IRFB3077 IRFB3207 IRFB7730 IRFB7734	IRFP7718	IRFS7730 IRFS7734	
		100 V		IRF100P218 IRFP4468	IRFS4010 IRF3610S	
		150 V	IRFB4115 IRFB4321 IPP046N15N5 IRFB4228 IRFB4019	IRF150P220	IRFS4321 IRFS4115 IRB048N15N5 IRFS4615	
Microcontrollers		XMC1300 series				



Unidirectional inverter stage

Battery voltage	Topology	MOSFET breakdown voltage	TO-220	TO-247	Gate drivers
200 V	Full-bridge inverter 120 V _{AC}	300 V	IPP410N30N IRFB4137	IRF300P226 IRF300P227 IRFP4868 IRFP4137	IRS211X IRS2186
400 V	Full-bridge inverter 220 V _{AC}	500 V	IPP50R280CE IPP50R380CE IPP50R190CE	IPW50R190CE	IRS211X IRS2186
Microcontrollers		XMC1300 series			

Unidirectional charger

Battery voltage	Topology	MOSFET breakdown voltage	TO-220	TO-247	PG-DIP-7
12-72 V	Flyback	650 V	CoolSET™		ICE3RBR1765JZ ICE3RBR0665JZ
12-72 V	Flyback	800 V	CoolMOS™ P7	IPP80R750P7 IPP80R600P7 IPP80R450P7 IPP80R360P7 IPP80R280P7	
Microcontrollers		Integrated, ICE3AS03LJG, ICE3BS03LJG			

Online UPS

Online UPS power stage

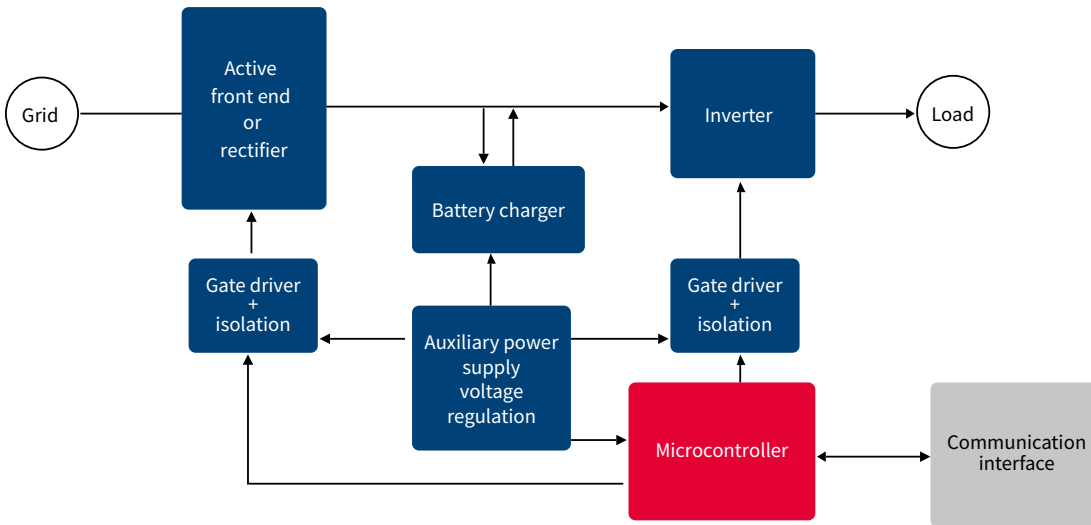

Stage	Topology	Voltage class	Technology	Part number
Rectifier	Three-phase	800 V/1600 V	EasyBRIDGE, EconoBRIDGE™	
PFC	Boost PFC / Vienna “T-type”	1200 V	TRENCHSTOP™ IGBT6	IKW40N120CS6 IKQ75N120CS6
	Boost PFC / Vienna rectifier	1200 V	CoolSiC™ MOSFET	F3L15MR12W2M1_B69
	Boost PFC / Vienna “T-type”	650 V	TRENCHSTOP™ 5 H5	IKW50N65EH5 IKW75N65EH5
	Boost PFC	600 V/1200 V	EasyPACK™	
	Boost PFC	1200 V	CoolSiC™ Schottky diode	
	PFC	600 V	CoolMOS™ P7	IPP60R060P7 IPB60R060P7
	PFC	600 V	CoolMOS™ C7	IPP60R040C7 IPB60R040C7
Inverter	NPC 1	650 V	TRENCHSTOP™ 5 H5	IKW50N65EH5 IKW75N65EH5 IKZ50N65EH5 IKZ75N65EH5
	NPC 1	650 V	TRENCHSTOP™ 5 S5	IKW50N65ESS IKW75N65ESS
	NPC 1	650 V	TRENCHSTOP™ HighSpeed3 IGBT Rapid diode	FS3L50R07W2H3F_B11
	NPC 2	1200 V	TRENCHSTOP™ IGBT6	IKW40N120CS6 IKQ75N120CS6
	NPC 2	1200 V	CoolSiC™ Schottky diode	
	NPC 2	1200 V	TRENCHSTOP™ HighSpeed3 IGBT Rapid diode	FS3L25R12W2H3_B11 F3L200R12W2H3_B11 F3L200R12W2H3_B47
	NPC 2	650 V	TRENCHSTOP™ 5 S5	IKW50N65ESS IKW75N65ESS
	Two-level	1200 V	EconoPACK™, EasyPACK™	FS75R12W2T4_B11 FS200R12KT4R_B11
	Two-level	1200 V	EconoDUAL™	FF600R12ME4_B11
Three-level NPC1	600 V/1200 V	EconoPACK™	F3L300R07PE4	
Battery charger	Half-bridge	1200 V	TRENCHSTOP™ IGBT6	IKW40N120CS6 IKQ75N120CS6
		1200 V	CoolSiC™ MOSFET	FF6MR12W2M1_B11
		650 V	TRENCHSTOP™ 5 H5	IKW50N65EH5 IKW75N65EH5
Gate driver ICs	Single-channel	1200 V	EiceDRIVER™ 1ED Compact	
AUX	-	650-800 V	CoolSET™	



Solar

High efficiency designs for solar power systems

Infiniteon provides a comprehensive portfolio to deliver the best efficiency and reliability for solar applications. Infiniteon's cutting edge technologies such as CoolMOS™ SJ MOSFETs, HighSpeed3 IGBT and TRENCHSTOP™ 5, CoolSiC™ Schottky diodes, CoolSiC™ MOSFETs, coreless transformer, driver, etc. combined with the rich experience and highest quality ensure the company's leader position in solar applications. The newly added ARM® Cortex™-M4 based MCU enables easy and high efficiency design.

	Optimizer 250-750 W	Single/Dual microinverter 250-600 W; 900 W	String inverter 1-60 kw	Central inverter 500-5000 kw
MOSFETs	OptiMOS™ SuperSO8/DirectFET™ 75-150 V	OptiMOS™ SuperSO8 60-200 V	OptiMOS™ 150-300 V	
SiC diodes		CoolMOS™ D ² PAK/ThinPAK 600-800 V	CoolMOS™ TO-247 600 V/650 V 19-99 mΩ	
IGBTs			CoolSiC™ MOSFET TO-247-3/TO-247-4 1200 V	
Gate driver ICs		2EDN EiceDRIVER™	650 V TRENCHSTOP™ 5 / 1200 V TRENCHSTOP™ IGBT6 TO-247-3/TO-247-4/TO-247PLUS 600 V/650 V/1200 V	PrimePACK™ / EconoDUAL™ 3 / MIPAQ™ Pro
Schottky diode			BAT165 Schottky diode	
Auxiliary power supply			CoolSET™ 800 V	
Microcontrollers	XMC1xxx ARM® Cortex®-M0	XMC1xxx ARM® Cortex®-M0	XMC1xxx ARM® Cortex®-M0	XMC1xxx ARM® Cortex®-M0
	XMC45xx ARM® Cortex®-M4	XMC45xx ARM® Cortex®-M4	XMC45xx ARM® Cortex®-M4	XMC45xx ARM® Cortex®-M4

Infiniteon's products for complete solar system

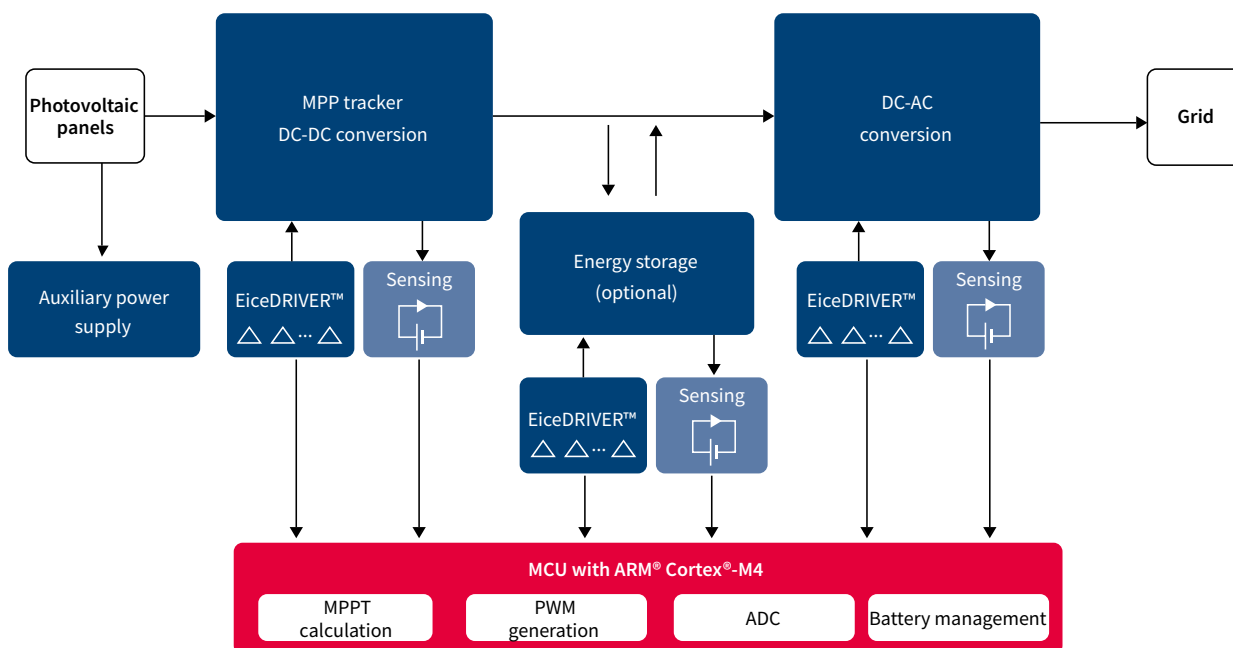

Microinverter

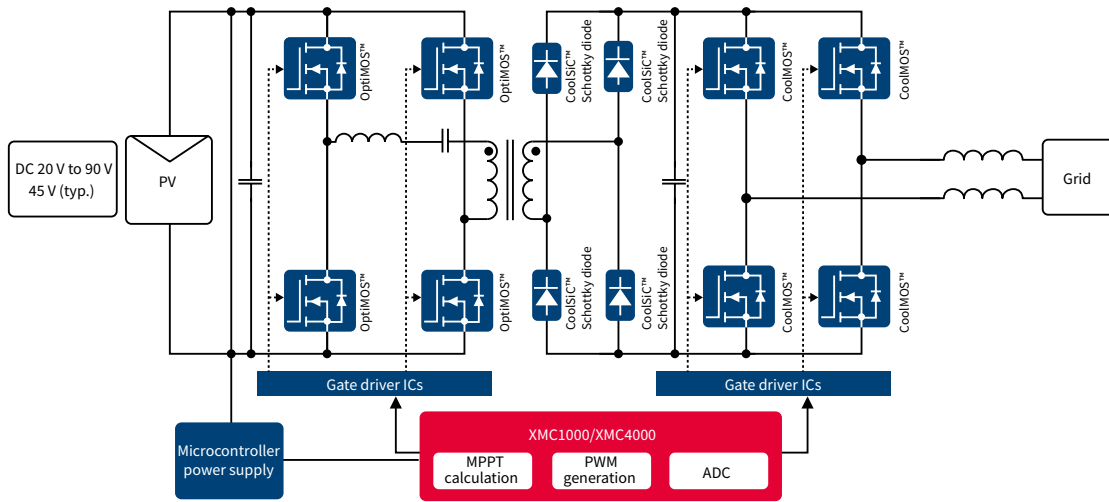

OptiMOS™ power MOSFETs for microinverter

Input voltage	Topology	MOSFET breakdown voltage	SuperSO8	DirectFET™	D ² PAK
Up to 48 V	Half-bridge, full-bridge, LLC and other resonant topologies	60 V	BSC012N06NS BSC019N06NS BSC028N06NS BSC039N06NS	BSB028N06NN3G	-
Up to 64 V	Half-bridge, full-bridge, LLC and other resonant topologies	80 V	BSC030N08NS5 BSC037N08NS5 BSC052N08NS5	BSB044N08NN3G BSB104N08NP3	-
Up to 80 V	Half-bridge, full-bridge, LLC and other resonant topologies	100 V	BSC035N10NS5 BSC040N10NS5	-	IPB020N10N5
Up to 60 V	Flyback	150 V	BSC093N15NS5 BSC108N15NS5 BSC160N15NS5 BSC175N15NS5	BSB165N15NZ3	IPB041N15N5 IPB063N15N5 IPB108N15N3G
	Push-pull	200 V	BSC320N20NS3G	-	IPB107N20N3G

CoolMOS™ SJ MOSFETs for microinverter

Topology	Package	Voltage class	Part number
Current source	D ² PAK	800 V	SPB17N80C3
Current/voltage source	D ² PAK	650 V	IPB65R190C7
			IPB65R125C7
			IPB65R095C7
			IPB65R065C7
			IPB65R045C7
	ThinPAK 8x8	600 V	IPL60R185P7
			IPL60R125P7
			IPL60R105P7
			IPL60R085P7
			IPL60R065P7
		650 V	IPL60R185C7
			IPL60R125C7
			IPL60R104C7
			IPL60R065C7
			IPL65R195C7
			IPL65R130C7
			IPL65R099C7
			IPL65R070C7

CoolSiC™ Schottky diodes for microinverter

Topology	Package	Voltage class	Part number
Rectifier	TO-252 (DPAK)	1200 V	IDM02G120C5
			IDM05G120C5
			IDM08G120C5
	D ² PAK	600 V	IDD05SG60C
		650 V	IDK04G65C5

Functional block	Product category	Product family	Benefits
PFC, PWM/resonant converter, synchronous rectification	Gate driver ICs	EiceDRIVER™ 1ED Compact	<ul style="list-style-type: none"> > 100 ns typical propagation delay time > Functional isolation > Separate source
		EiceDRIVER™ 2EDNx	<ul style="list-style-type: none"> > 8 V UVLO option > (-)10 V input robustness > Output robust against reverse current

Microcontrollers for microinverter

Topology	Package	Voltage class	Technology
Microcontroller	All	All	XMC1000
Microcontroller supply	Linear voltage regulator	Up to 20 V	IFX1763, IFX54441, IFX54211
Microcontroller	All	All	XMC4000

Optimizer

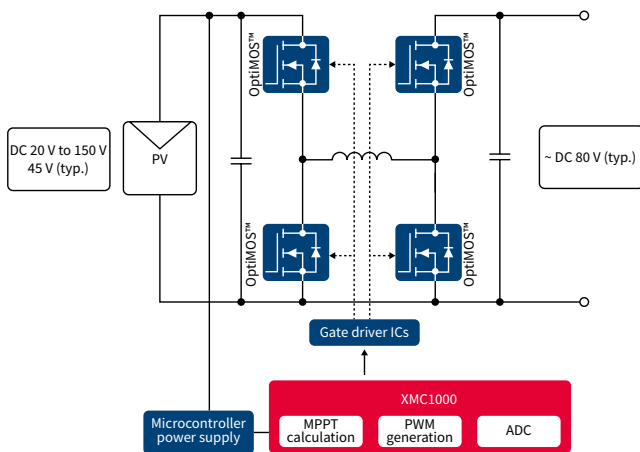

OptiMOS™ MOSFETs for optimizer DC-DC power conversion

Input voltage	Topology	MOSFET breakdown voltage	SuperSO8	S308/PQFN 3.3 x 3.3	DirectFET™	D ² PAK and DPAK
Up to 48 V	Buck-boost	60 V	BSC012N06NS BSC016N06NS	BSZ042N06NS	BSB028N06NN3G	IPB026N06N
Up to 64 V	Buck-boost	80 V	BSC027N08NS5 BSC040N08NS5 BSC052N08NS5 BSC117N08NS5	BSZ075N08NS5 BSZ084N08NS5 BSZ110N08NS5	BSB044N08NN3G	IPB017N08N5 IPB031N08N5 IPB049N08N5
Up to 80 V	Buck-boost	100 V	BSC035N10NS5 BSC040N10NS5 BSC060N10NS3	BSZ097N10NS5	BSB056N10NN3 BSF134N10NJ3G	IPB020N10N5
Up to 125 V	Buck-boost	200 V	BSC320N20NS3G	BSZ900N20NS3 G	-	IPD320N20N3G

Microcontrollers for power optimizer

Topology	Package	Voltage class	Technology
Microcontroller	All	All	XMC1000
Microcontroller supply	Linear voltage regulator	Up to 20 V	IFX1763, IFX54441, IFX54211
Microcontroller	All	All	XMC4000

Single-phase string inverter – multilevel topology

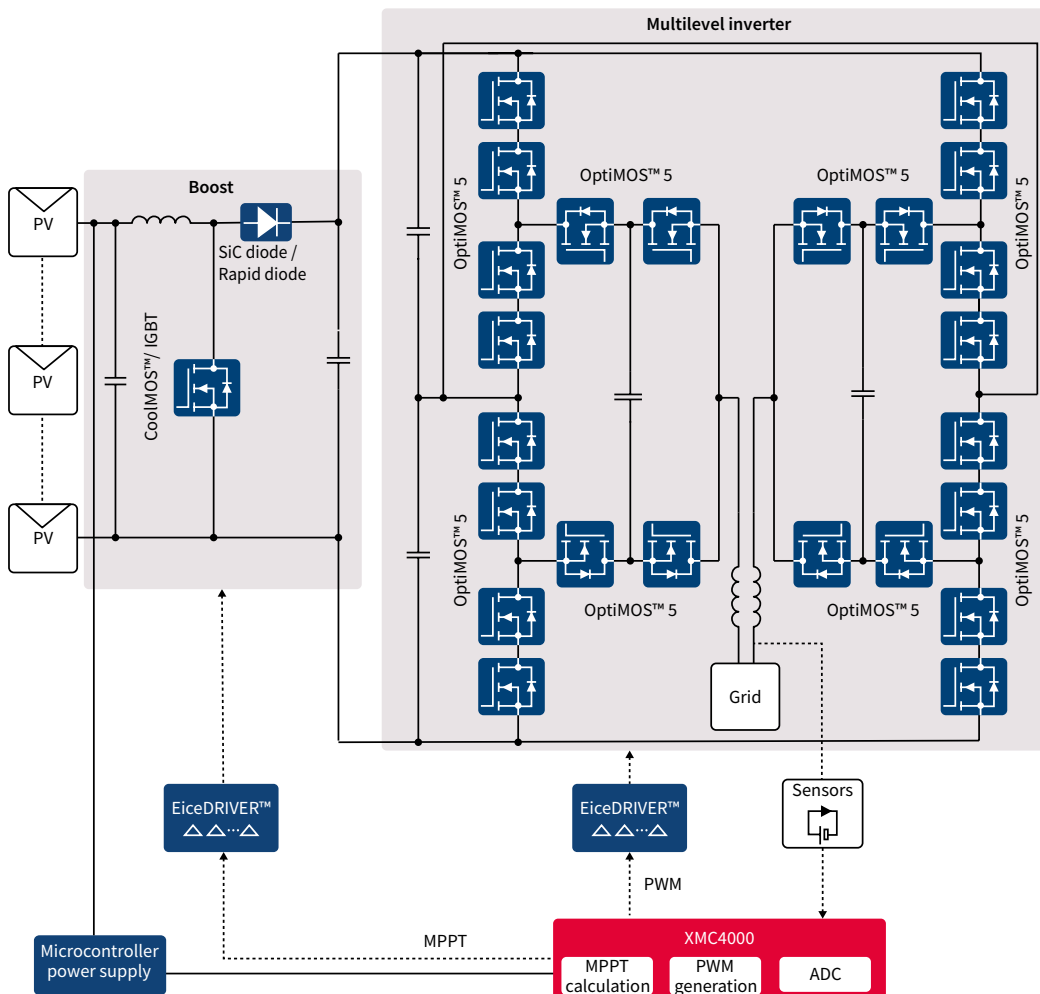

In multilevel inverter, four high voltage MOSFETs/IGBTs in H-bridge topology are replaced with a higher number of lower voltage MOSFETs. Compared to a conventional H-bridge inverter, a multilevel inverter, composed of lower voltage MOSFETs, offers several advantages:

- › With much lower $R_{DS(on)}$ and switching loss parameters it significantly reduces conduction and switching losses
- › Higher effective output frequency (smaller magnetics) is possible with lower switching losses
- › Improved EMC due to reduced switching voltages
- › Significant reduction in cooling system, size and weight

Discrete power devices for multilevel string inverter

Topology	MOSFET breakdown voltage	Family	SuperSO8	D ² PAK	TO-220	TO-247
Flying-capacitor-based active neutral-point-clamp multilevel inverter	150 V	OptiMOS™ 5	BSC093N15NS5 BSC110N15NS5 BSC160N15NS5	IPB044N15N5 IPB048N15N5 IPB060N15N5 IPB073N15N5	IPP051N15N5 IPP076N15N5	–

Single-phase string inverter (non-isolated) – standard solution

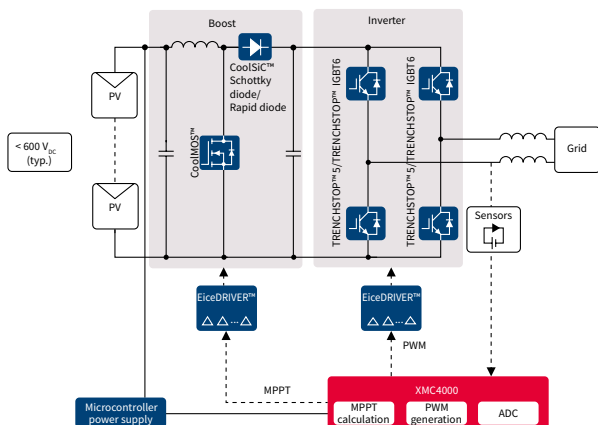

Three-phase string inverter

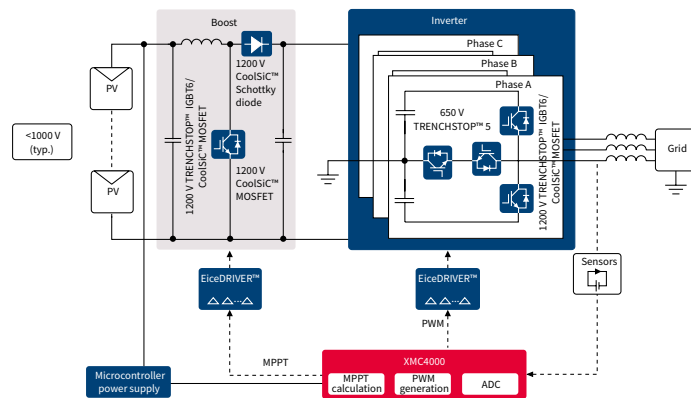

Discrete power devices for string inverter

Inverter type	Function	Product series	Voltage class	Part number	
Single-phase	Boost	CoolMOS™ C7	600 V	IPW60R040C7	
		CoolSiC™ diode	650 V	IDW20G65C5	
		Rapid diode	650 V	IDW15E65D2	
	Inverter	TRENCHSTOP™ IGBT3	600 V	IKW40N60H3	
		TRENCHSTOP™ 5 H5	650 V	IKW40N65H5	
		CoolMOS™ P7	600 V	IPW60R037P7	
Three-phase	Boost	TRENCHSTOP™ IGBT6	1200 V	IKW40N120CS6 IKQ75N120CS6 IKY75N120CS6	
		CoolSiC™ MOSFET	1200 V	IMW120R045M1 IMZ120R045M1	
		CoolSiC™ Schottky diode generation 5	1200 V	IDW20G120C5B IDW30G120C5B IDW40G120C5B	
		Inverter	TRENCHSTOP™ IGBT6	1200 V	IKW40N120CS6 IKQ75N120CS6 IKY75N120CS6
			TRENCHSTOP™ 5 S5	650 V	IKW40N65ES5
			TRENCHSTOP™ 5 L5	650 V	IKW30N65EL5

Gate driver ICs for string inverter

Power device	Driving method	Voltage class	Part number
IGBT/SiC MOSFET	Single-channel	1200 V	EiceDRIVER™ 1ED Compact EiceDRIVER™ Enhanced 1ED020I12-F2
IGBT/SiC MOSFET	Half-bridge and high- and low-side	1200 V	EiceDRIVER™ Enhanced 2ED020I12-F2/FI

CoolSET™ for string inverter

Voltage class	Part number
800 V	ICE3AR2280JZ
650 V	ICE3BR1765JZ

Microcontrollers for string inverter

Topology	Package	Voltage class	Technology
Microcontroller	All	All	XMC1000
Microcontroller supply	Linear voltage regulator	Up to 20 V	IFX1763, IFX54441, IFX54211
Microcontroller	All	All	XMC4000

For Infineon's extensive module portfolio for string and central inverters, visit:

www.infineon.com/solar

www.infineon.com/igbtmodules1200v



Wireless charging solutions

Cost-effective and secure offerings for consumer, industrial and automotive applications

Over the last years, wireless charging has gained more and more traction in the market and is expected to heavily influence our daily lives in future. Infineon offers a broad portfolio of efficient, high-quality products and solutions to serve the key requirements of the dominant market standards: inductive (Qi (WPC)) and resonant (AirFuel). Whether you charge a smartphone (e.g. at home or in the car), a handful of wearables, a power tool, a laptop or a service robot, Infineon's components and solutions help you overcome a wide range of common wireless power transfer challenges for consumer, industrial and automotive wireless charging designs.

Wireless charging standards

	Inductive single-coil	Inductive multi-coil	Magnetic resonance
Standard	Qi inductive 110-205 kHz		Resonant AirFuel 6.78 MHz
Positioning of receiver application	Exact positioning	Positioning more flexible (X and Y direction)	Free positioning (up to >30 mm vertical freedom)
Number of devices charged	Charges only one device	Charges one device but with better user experience	Charges multiple devices
Rx-Tx communication	In-band communication		Bluetooth low energy or in-band communication

Many end markets for wireless battery charging



Infineon's key enabling products for consumer, industrial and automotive solutions

- > Low and medium voltage power MOSFETs – OptiMOS™ and StrongIRFET™
- > Gate driver ICs – EiceDRIVER™ or DC-DC low voltage gate driver
- > 32-bit microcontrollers – XMC™ and AURIX™
- > Wireless power controller (including software IP) – XMC™-SC and AURIX™
- > P-channel and N-channel small signal power MOSFETs
- > High voltage power MOSFETs – CoolMOS™ superjunction MOSFETs
- > PWM/flyback controllers and integrated power stage ICs – CoolSET™
- > Gallium nitride (GaN) – CoolGaN™ e-mode HEMTs
- > Dedicated automotive power products – MOSFETs, DC-DC, LDO, PMIC with ASIL qualification
- > Voltage and buck regulators for component and bridge supply
- > Authentication – OPTIGA™ Trust UWP

www.infineon.com/wirelesscharging

Components for inductive designs for consumer and industrial applications

Especially for the emerging higher power (15 W+) transmitter applications equipping your half- or full-bridge topologies with components from the OptiMOS™ product family, driver ICs, and voltage regulators pays off with superior power transfer performance. Single and dual N-channel OptiMOS™ versions with excellent $R_{DS(on)}$ and charge characteristics are available in small footprint packages for your wireless power transmitter design. For multicoil designs, there are very suitable IR MOSFET™ devices in 2 x 2 mm packages ready to use. In addition, Infineon's XMC™ 32-bit industrial microcontrollers provide the flexibility to charge “just about anything”. Infineon's portfolio supports individual needs by either an ARM® Cortex®-M0 core (XMC1000 family) or a Cortex®-M4 core with a floating point unit (XMC4000 family). In addition, wireless power controllers – XMC™-SC, including software IP, are available for selected applications in our portfolio (for further details check **page 261**). Ensuring that you, your data, and your devices remain secured and safe during charging, Infineon adds a new member to its OPTIGA™ Trust family – the OPTIGA™ Trust UWP. Infineon readily supports the WPC Qi authentication standard with an integrated turnkey solution.

System diagram: inductive wireless charging

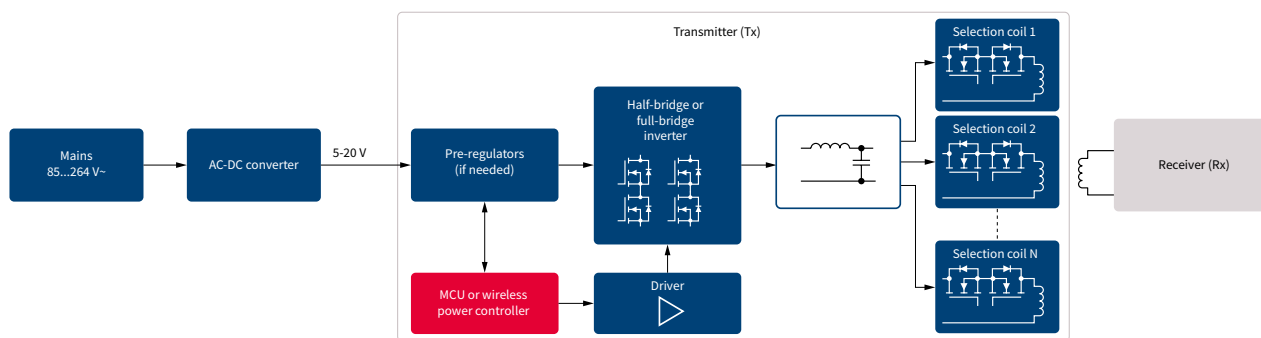

Inductive (Qi) and low frequency transmitter solutions

Products	Voltage class	Package	Part number	$R_{DS(on)}$ max @ $V_{GS} = 4.5$ V [mQ]	Recommendation
MOSFETs	20 V	PQFN 2 x 2	IRLHS6242	11.7 (= 2.5 V drive capable)	Right fit
	25 V		IRFHS8242	21	Right fit
	30 V	Super SO8	BSC0996NS	11.8	Right fit
			BSC0993ND	7	Best performance
		PQFN 3.3 x 3.3	BSZ0589NS	4.4	Best performance
			BSZ0994NS	8.6	Right fit
			BSZ0909NS	15	Right fit
			BSZ0909ND	25	Best performance
	PQFN 3.3 x 3.3 dual	BSZ0910ND	13	Best performance	
		IRFHS8342	25	Right fit	
40 V	PQFN 3.3 x 3.3	IRLHS6342	15.5 (= 2.5 V drive capable)	Best performance	
		BSZ097N04LS	14.2	Right fit	
Driver ICs	PX3519, IRS2301S, WCDSC006*				
Microcontroller or wireless power controller	XMC™ MCU and wireless power controller XMC™-SC* (including software IP)				
Voltage regulators	IR3841M, IFX20002, IFX91041EJV50, IFX90121ELV50, IFX81481ELV				
Small signal MOSFETs	Please check online ¹⁾				
Authentication	SLS32AIA020Ux – OPTIGA™ Trust UWP (USON10 3 x 3 package)				

Find here additional MOSFET and driver IC offerings!

www.infineon.com/cms/en/tools/solution-finder/product-finder/gate-driver

www.infineon.com/cms/en/tools/solution-finder/product-finder/mosfet-finder

www.infineon.com/wirelesscharging

* Coming soon

1) www.infineon.com/smallsignalmosfets

Components for resonant designs for consumer and industrial

Infiniteon offers superior power MOSFET technology especially in the 30-100 V classes for class D inverter designs and in the 150-250 V voltage classes for class E inverters to address MHz switching implementations. We provide industry leading products when it comes to fast switching and have the best figure of merit for gate charge times $R_{DS(on)}$ and for C_{oss} thus enabling our customer to achieve 6.78 MHz inverter designs using robust silicon MOSFET technology. CoolGaN™ 600 V with low and highly linear C_{oss} , as well as low Q_c , enables high efficiency at higher power levels, especially in higher power class E designs. The CoolGaN™ portfolio qualifying for the use in wireless charging applications will be extended by adding 100 V and 200 V products over the next years. Infineon offers the “coolest” driver ICs in the industry, already available as low-side drivers for class E implementations and very soon as level shifted half-bridge driver for class D topologies. If your transmitter design uses a pre-regulator (buck or buck/boost) to control the input voltage of your amplifier you can find OptiMOS™ solutions in the **20-300 V MOSFETs** section. Here again, the XMC™ industrial microcontroller and the XMC™-SC wireless power controller, including software IP, are a great fit to charge “just about anything”.

System diagram: resonant wireless charging – class D, full-bridge

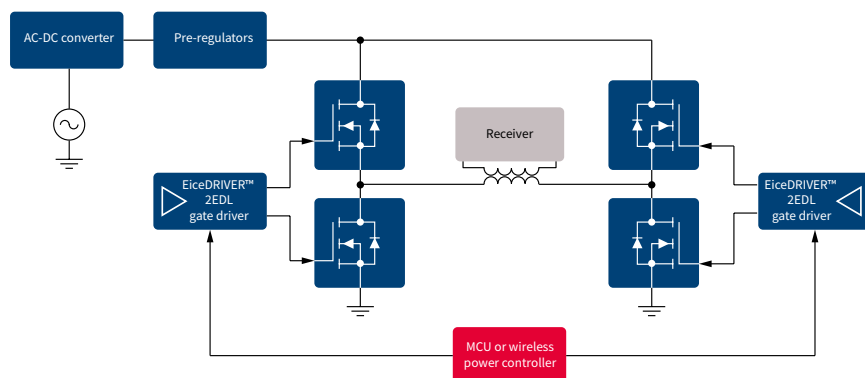

Make use of our evaluation boards for low cost charger and adapter applications (see pages 34 and 36).

Components for resonant (AirFuel) and high frequency solutions

Products	Voltage class	Package	Part number	$R_{DS(on)}$ max @ $V_{GS} = 4.5$ [mQ]	Q_c typical [nC]	C_{oss} typical [pF]	Topology
MOSFETs	30 V	PQFN 2 x 2 dual	IRLHS6376PBF	48	2.8	32	Class D
		PQFN 3.3 x 3.3 dual	BSZ0909ND	25	1.8	120	Class D
			BSZ0910ND	13	5.6	230	Class D
		SOT-23	IRLML0030PBF	33	2.75	84	Class D
	40 V	SOT-23	IRLML0040	62	2.8	49	Class D
	60 V	SOT-23	IRLML0060	98	2.6	37	Class D
	80 V	PQFN 2 x 2	IRL80HS120	32	3.5	68	Class D/E
	100 V	PQFN 2 x 2	IRL100HS121	42	2.7	62	Class D/E
	150 V	PQFN 3.3 x 3.3	BSZ900N15NS3	75**	4.1**	46	Class E
			BSZ520N15NS3	42**	7.2**	80	Class E
			BSZ900N20NS3	78**	7.2**	52	Class E
			BSZ22DN20NS3	200**	3.5**	24	Class E
BSZ12DN20NS3			111**	5.4**	39	Class E	
200 V		BSZ42DN25NS3	375**	3.6**	21	Class E	
250 V							
Driver ICs	EiceDRIVER™ 2EDL71*, 1EDN7512, 2EDN7524 GaN EiceDRIVER™ ICs 1EDS5663H, 1EDF5673F, 1EDF5673K						
GaN e-mode HEMT	CoolGaN™ 600 V e-mode GaN HEMT IGT60R190D1S (HSOF-8-3)						
Microcontroller or wireless power controller	XMC™ MCU and wireless power controller XMC™-SC* (including software IP)						
Voltage regulators	IR3841M, IFX20002, IFX91041EJV50, IFX90121ELV50, IFX81481ELV						
Small signal MOSFETs	Please check online ¹⁾						

Find here additional MOSFET and driver IC offerings!

www.infineon.com/cms/en/tools/solution-finder/product-finder/gate-driver
www.infineon.com/cms/en/tools/solution-finder/product-finder/mosfet-finder

www.infineon.com/wirelesscharging

* Coming soon
 ** $V_{GS} = 8$ V

1) www.infineon.com/smallsignalmosfets

Wireless in-car charging (automotive)

The next generation of in-cabin wireless charging systems have to meet strict automotive safety, security, environmental and regulatory requirements while still enabling industry-leading charging performance and efficiency. Infineon’s AURIX™ microcontroller, voltage regulators, power MOSFET technologies and network ICs will easily support these requirements with a complete charging solution. With 15 W charging that meets existing standards, including fast charge smartphones, the solution easily supports future changes with a software update. Infineon’s new innovative foreign object detection (FOD) system or our unique improved power drive architecture that provides unparalleled EMI performance are just two benefits out of many to address the design challenges in the automotive wireless charging market. Discover our complete offerings for in-cabin charging on a system level on **Infineon’s wireless charging webpage** – something you will not find just anywhere.

System diagram: AURIX™-based wireless charger – three-coil

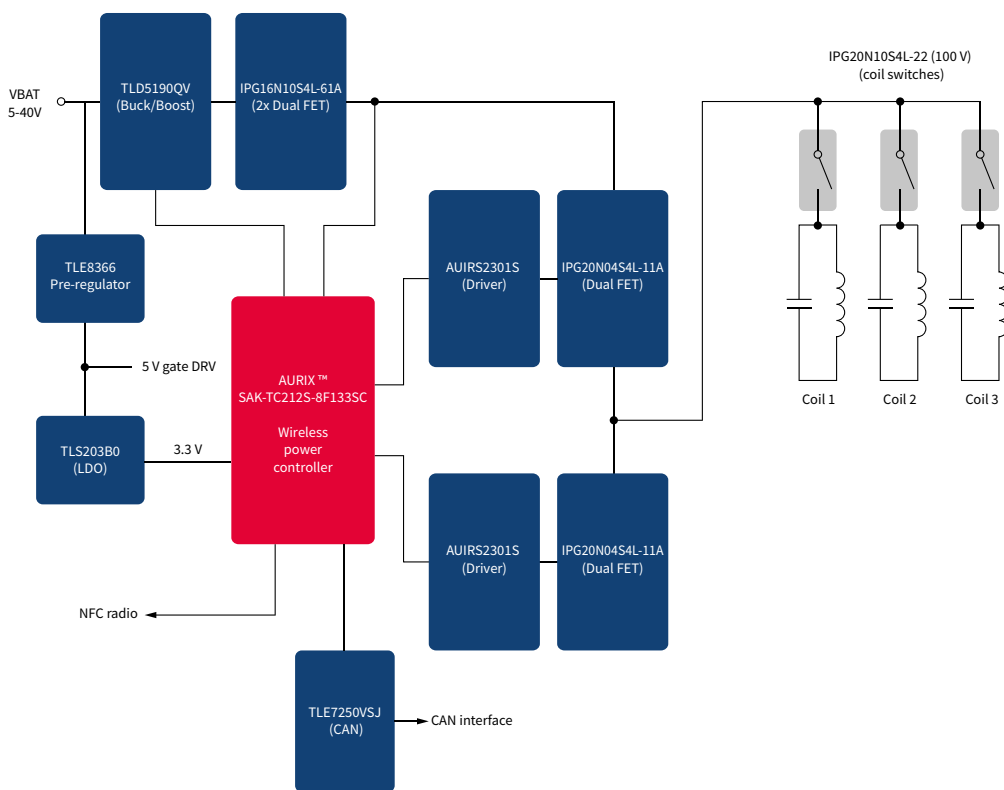

Automotive products for wireless charging	Voltage class	Package	Part number	$R_{DS(on)}$ max @ $V_{GS} = 4.5$ V [mQ]	Q_c typical [nC]
Inverter automotive grade MOSFETs	40 V	SuperSO8 5 x 6 Dual	IPG20N04S4-12A	15.5	9
		S308 3.3 x 3.3	IPZ40N04S5L-4R8	6.7	11
			IPZ40N04S5L-7R4	10.7	6.5
Automotive products for wireless charging	Voltage class	Package	Part number	$R_{DS(on)}$ max @ $V_{GS} = 4.5$ V [mQ]	$R_{DS(on)}$ max @ $V_{GS} = 10$ V [mQ]
Coil selection switch	60 V	TDSO8-8	IPG20N06S4L-11A	15.8	11.2
	100 V	SuperSO8 5 x 6 Dual	IPG20N10S4L-22A	28	22
			IPG20N10S4L-35A	45	35
		IPG16N10S4L-61A	78	61	
Microcontroller and wireless power controller	AURIX™ SAK-TC212S-4F100N, SAK-TC212S-8F133SC				
Power supply	TLD5190 – buck-boost controller/TLE8366, TLS4120x, TLS203x/TLF35584 – safety MCU supply + CAN supply				
CAN	TLE7250SJ – high performance CAN transceiver				
Drivers	AUIRS2301S				

System solutions for wireless charging

Master your design challenges with Infineon. With our broad range of designs, customers have the possibility to make wireless charging available for different kinds of applications. For more information on the availability of our boards please visit www.infineon.com/wirelesscharging or get in contact with us via www.infineon.com/support.

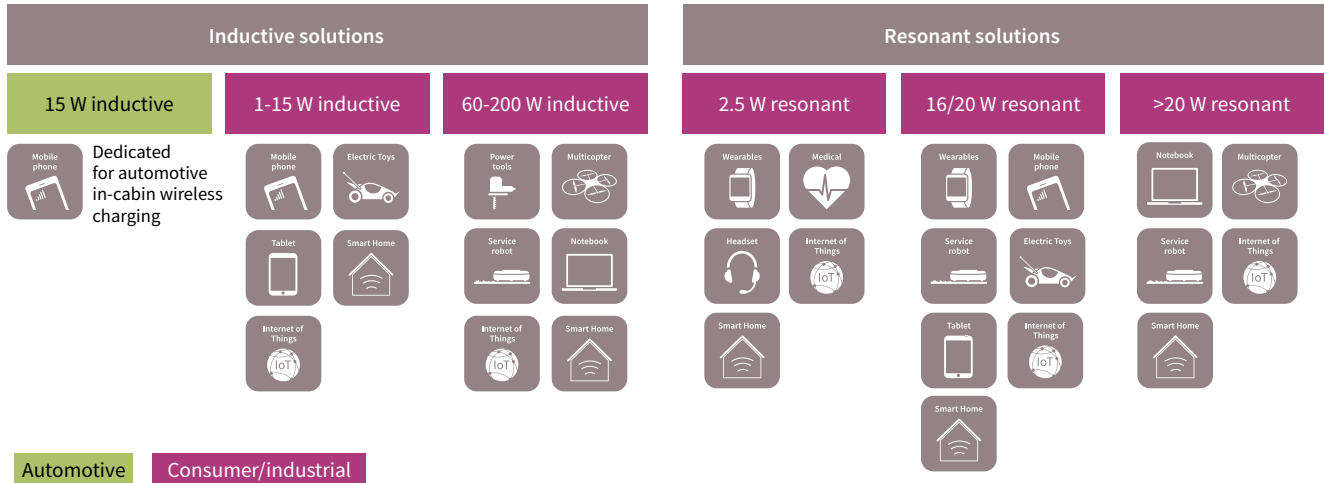

Find the right solutions for your wireless charging designs in four steps

Infineon's selection tool for wireless charging allows you to find the right solutions for your designs in just four steps: select the application, power range, standard and the topology you want to apply and get an overview of Infineon's most recommended offerings.



Try now!



Infineon support for applications

Useful links and helpful information

Learn more about our system solutions for your application.

Find block diagrams, evaluation boards, interactive 3D models, videos, tools and related material for download.

www.infineon.com/audio
www.infineon.com/automation
www.infineon.com/consumer
www.infineon.com/dataprocessing
www.infineon.com/emobility
www.infineon.com/ev-charging
www.infineon.com/homeappliance
www.infineon.com/industrial-robotics
www.infineon.com/lev
www.infineon.com/lighting

www.infineon.com/microwave
www.infineon.com/motorcontrol
www.infineon.com/multicopter
www.infineon.com/optiga
www.infineon.com/service-robotics
www.infineon.com/smps
www.infineon.com/solar
www.infineon.com/ups
www.infineon.com/welding
www.infineon.com/wirelesspower

Videos

www.infineon.com/mediacenter

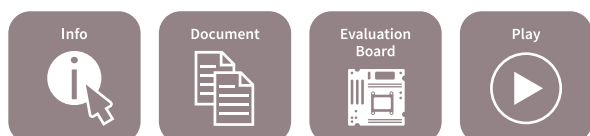



OptiMOS™ and StrongIRFET™

20-300 V MOSFETs N-channel power MOSFETs

Infineon's semiconductors are designed to bring greater efficiency, power density and cost-effectiveness. The full range of OptiMOS™ and StrongIRFET™ power MOSFETs enables innovation and performance in applications such as switch mode power supplies (SMPS), battery powered applications, motor control and drives, inverters, and computing.

Infineon's highly innovative OptiMOS™ and StrongIRFET™ families consistently meet the highest quality and performance demands in key specifications for power system designs such as on-state resistance ($R_{DS(on)}$) and figure of merit (FOM).

OptiMOS™ power MOSFETs provide best-in-class performance. Features include ultralow $R_{DS(on)}$, as well as low charge for high switching frequency applications. StrongIRFET™ power MOSFETs are designed for drives applications and are ideal for designs with a low switching frequency, as well as those that require a high current carrying capability.

StrongIRFET™	OptiMOS™
Robust and excellent price/performance ratio	Best-in-class technology
Designed for industrial applications	Designed for high performance applications
Optimized for low switching frequency	Optimized for high switching frequency
High current carrying capability	Industry's best figure of merit
Rugged silicon	High efficiency and power density
	

www.infineon.com/powermosfet-12V-300V

Technology development and product family positioning

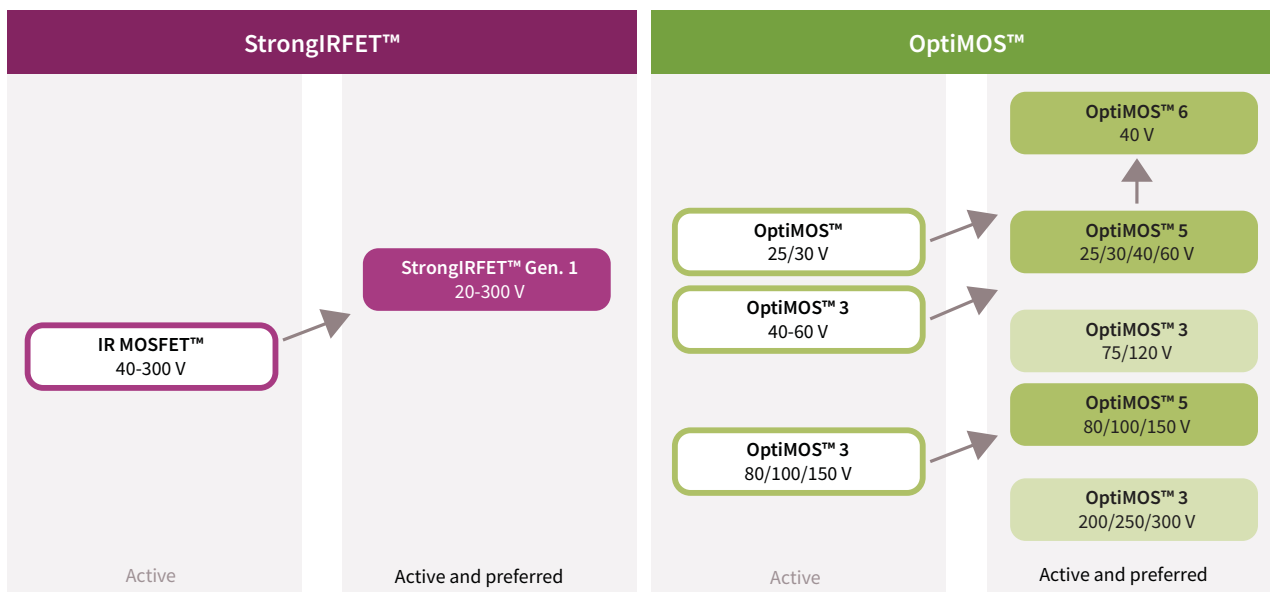

Infineon's power MOSFET 20-300 V product portfolio is divided into „active and preferred“, referring to the latest technology available offering best-in-class performance, as well as „active“, which consists of well-established technologies which complete this broad portfolio.

OptiMOS™ 6 power MOSFETs 40 V are the newest addition to the OptiMOS™ product family available either in SuperSO8 or PQFN 3.3 x 3.3 packages. This technology is the perfect solution when best-in-class (BiC) products and high efficiency over a wide range of output power are required. For the other voltage classes, from 25 V up to 150 V, OptiMOS™ 5 represents the latest generation in the market, offering either best in class (BiC) or price/performance solutions. For high frequency applications, the product portfolio is complemented by OptiMOS™ 3 power MOSFETs 40-50 V as standard components. The „active and preferred“ OptiMOS™ 3 power MOSFETs 75-120 V, as well as 200-300 V is the best fit portfolio either in low or high frequency applications with a range of products covering from BiC to standard parts.

StrongIRFET™ Gen. 1 is recommended for 20-300 V applications when BiC performance is not essential and cost is a more significant consideration.

The diagrams below summarize the recommended technology for best fit standard components, price/performance and differentiated products according to switching frequency.

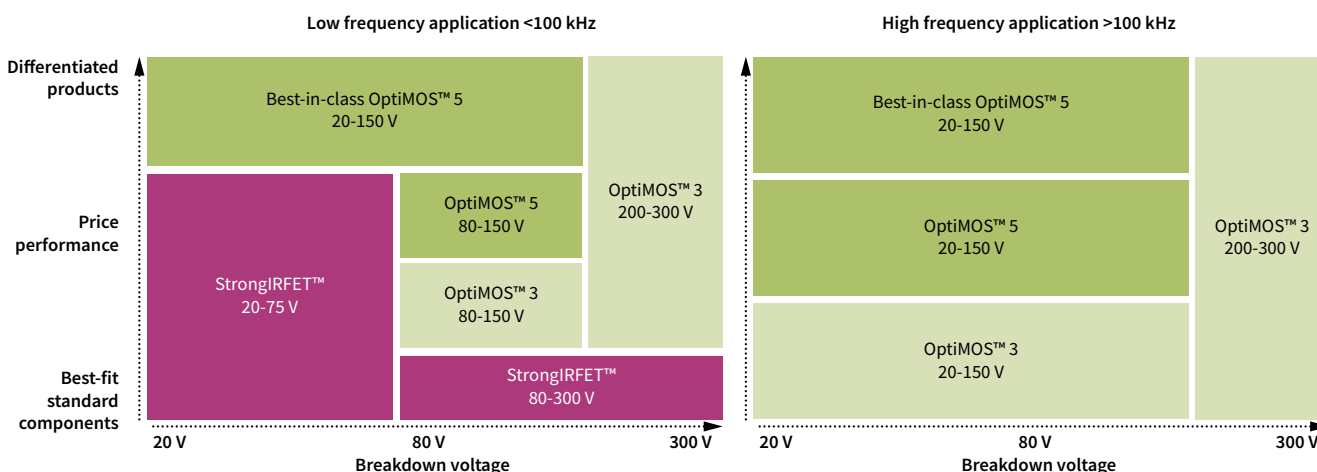

www.infineon.com/powermosfet-12V-300V

Guidance for applications and voltage classes

OptiMOS™ and StrongIRFET™ portfolio, covering 20 up to 300 V MOSFETs, can address a broad range of needs from low to high switching frequencies. The tables below provide a guidance overview for the recommended OptiMOS™ or StrongIRFET™ products for each major sub-application and voltage class.

Recommended voltage		20 V to 30 V	40 V	60 V	75 V to 80 V	100 V	135 V to 150 V	200 V	250 V	300 V	
Battery powered	Low power Power tools, Multicopter, Battery, Industrial Drives	OptiMOS™	✓	✓	✓	✓					
		StrongIRFET™	✓	✓	✓	✓					
	High power (LEV, LSEV)	OptiMOS™			✓	✓	✓	✓	✓		
		StrongIRFET™			✓	✓	✓	✓	✓		
Inverters	Solar	OptiMOS™			✓	✓	✓	✓			
		StrongIRFET™			✓	✓	✓				
	UPS	slow switching									
		OptiMOS™	✓	✓	✓	✓	✓	✓	✓	✓	✓
		StrongIRFET™	✓	✓	✓	✓	✓	✓	✓	✓	✓
		fast switching									
		OptiMOS™	✓	✓	✓	✓	✓	✓	✓	✓	✓
		StrongIRFET™	✓	✓	✓	✓	✓	✓	✓	✓	✓
	Offline	OptiMOS™		✓	✓						
		StrongIRFET™		✓	✓						
SMPS	Adapter / Charger	OptiMOS™		✓	✓	✓	✓				
		StrongIRFET™		✓	✓	✓	✓				
	PC Power	OptiMOS™		✓	✓						
		StrongIRFET™		✓	✓						
	LCD TV	OptiMOS™			✓	✓	✓				
		StrongIRFET™			✓	✓	✓				
	Server	OptiMOS™		✓	✓	✓					
		StrongIRFET™		✓	✓	✓					
	AC-DC	OptiMOS™				✓	✓	✓	✓		
		StrongIRFET™				✓	✓				
	Telecom	OptiMOS™	✓	✓	✓	✓	✓	✓			
		StrongIRFET™	✓	✓	✓	✓	✓				





StrongIRFET™ recommended





OptiMOS™ recommended

StrongIRFET™ available

OptiMOS™ available

Space saving and high performance packages

	TO-247	TO-220	D ² PAK	D ² PAK 7-pin	TO-leadless
					
	Optimized for high power applications and high current capability				
Height [mm]	5.0	4.4	4.4	4.4	2.3
Outline [mm]	40.15 x 15.9	29.5 x 10.0	15.0 x 10.0	15.0 x 10.0	11.68 x 9.9
Current capability [A]	195.0	195.0	195.0	240.0	300.0
Thermal resistance R _{thJC} [K/W]	2.0	0.5	0.5	0.5	0.4

	SuperSO8	Power Block	PQFN 3.3 x 3.3	PQFN 2 x 2	DirectFET™
					
	For highest efficiency and power management	Significant design shrink	For highest efficiency and power management	Enables significant space saving	Best thermal behavior in a tiny footprint
Height [mm]	1.0	1.0	1.0	0.9	Small: 0.65 Medium: 0.65 Large: 0.71
Outline [mm]	5.15 x 6.15	5.0 x 6.0	3.3 x 3.3	2.0 x 2.0	Small: 4.8 x 3.8 Medium: 6.3 x 4.9 Large: 9.1 x 6.98
Current capability [A]	100.0	50.0	40.0	18.5	Small: 75.0 Medium: 180.0 Large: 375.0
Thermal resistance R _{thJC} [K/W]	0.8	1.5	3.2	11.1	0.5

Discrete and integrated packages

OptiMOS™ and StrongIRFET™ technologies are available in different packages to address the demands for higher current carrying capability and significant space saving.

The broad portfolio enables footprint reduction, boosted current rating, and optimized thermal performance. While the surface mount leadless devices enable footprint reduction, through-hole packages are characterized by a high power rating.

Furthermore, Infineon offers innovative packages such as DirectFET™ and TO-leadless. DirectFET™ is designed for high frequency applications by offering lowest parasitic resistance. This package is available in three different sizes: small, medium and large. TO-leadless is optimized to handle currents of up to 300 A, increasing power density with a substantial reduction in footprint.

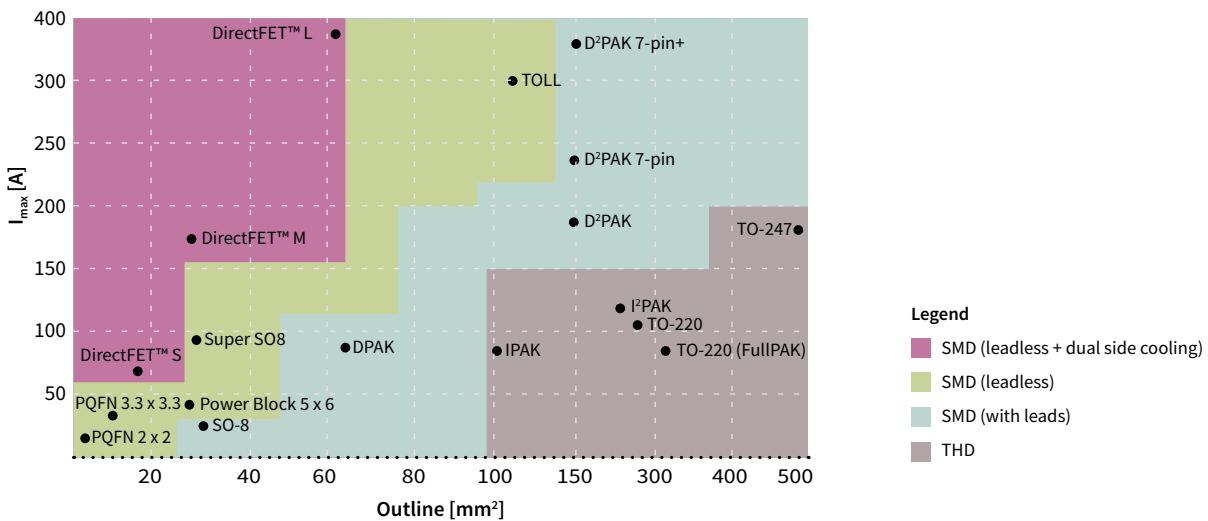

Small signal and small power MOSFETs

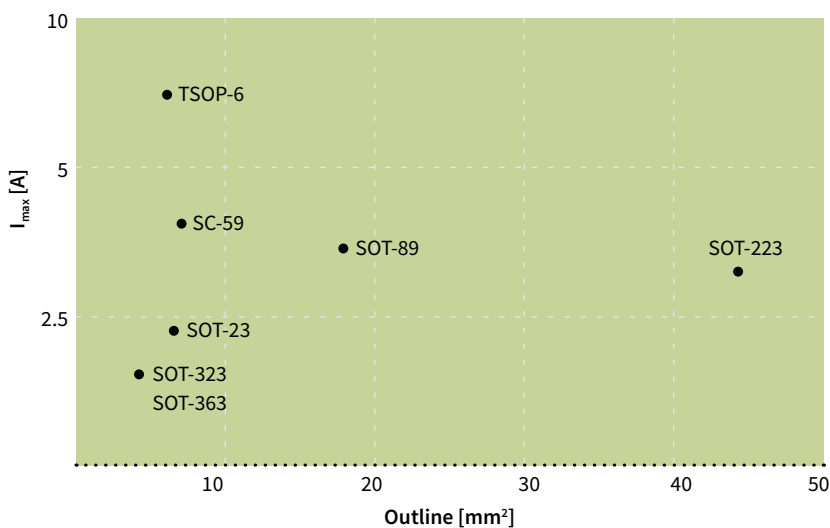

Small signal and small power MOSFETs are available in eight industry-standard package types ranging from the largest SOT-223 to the smallest SOT-363.

Products are offered in single, dual and complementary configurations and are suitable for a wide range of applications, including battery protection, LED lighting, low voltage drives and DC-DC converters.

OptiMOS™ Linear FET

Combining low on-state resistance ($R_{DS(on)}$) with wide safe operating area (SOA)

OptiMOS™ Linear FET is a revolutionary approach to avoid the trade-off between on-state resistance ($R_{DS(on)}$) and linear mode capability operation in the saturation region of an enhanced mode MOSFET. It offers the state-of-the-art $R_{DS(on)}$ of a trench MOSFET, as well as the wide safe operating area of a classic planar MOSFET.

This new product is the perfect fit for hot swap and e-fuse applications commonly found in telecom and battery management systems. OptiMOS™ Linear FET prevents damage at the load in case of a short circuit by limiting high inrush currents.

OptiMOS™ Linear FET is currently available in three voltage classes – 100 V, 150 V, and 200 V – in either D²PAK or D²PAK 7-pin package.

SOA comparison

Whilst the OptiMOS™ 5 100 V, 1.7 mΩ power MOSFET has a SOA of 0.5 A, the OptiMOS™ Linear FET version at the same $R_{DS(on)}$ offers a much wider SOA of 11.5 A (@ 54 V, 10 ms).

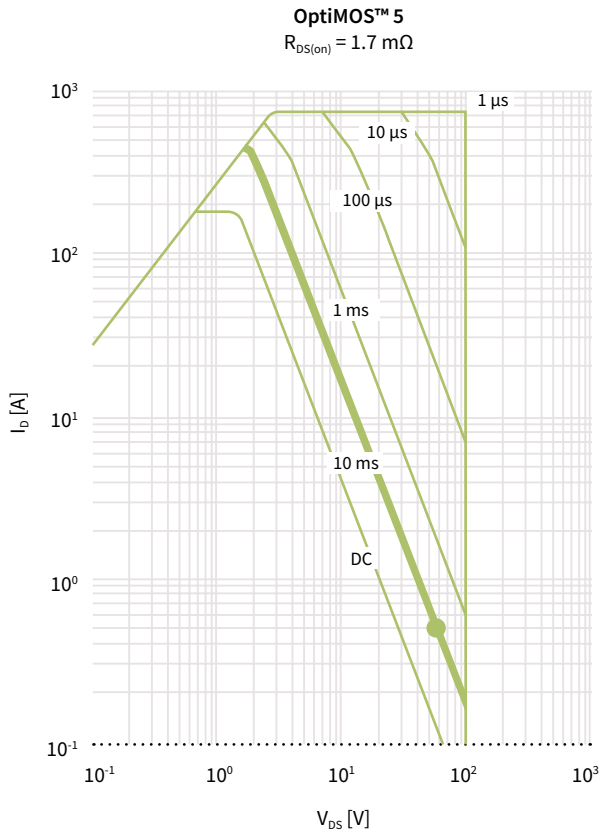

0.5 A @ 54 V
 $t_{pulse} = 10\text{ ms}$

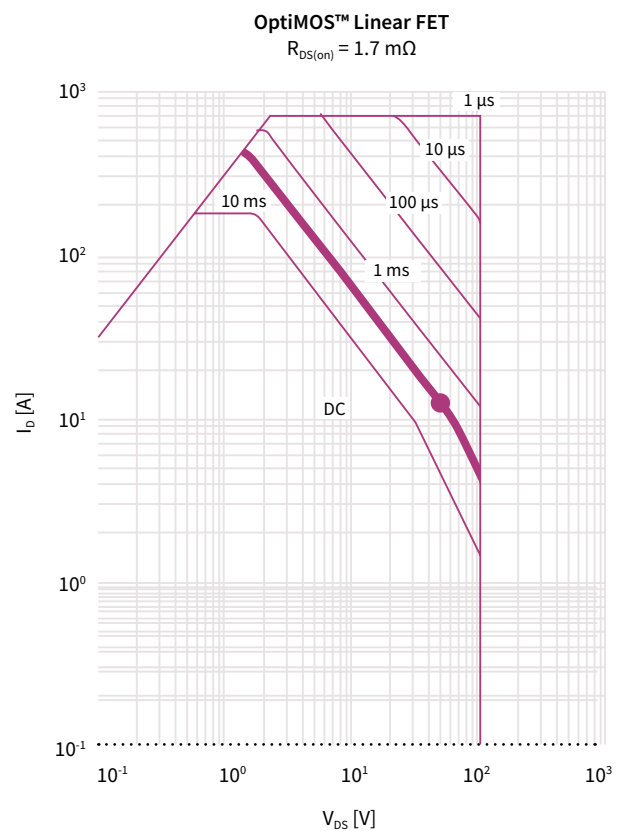

11.5 A @ 54 V
 $t_{pulse} = 10\text{ ms}$

www.infineon.com/optimos-linearfet

OptiMOS™ 6 power MOSFETs 40 V

Next generation of cutting edge MOSFETs

OptiMOS™ 6 40 V devices are setting a new technology standard in the field of discrete MOSFET devices. Compared to alternative products, Infineon's leading thin wafer technology enables significant performance benefits compared to OptiMOS™ 5:

- > $R_{DS(on)}$ reduced by 30%
- > Improved FOM $Q_g \times R_{DS(on)}$ by 29%
- > Improved FOM $Q_{gd} \times R_{DS(on)}$ by 46%

Infineon's OptiMOS™ 6 power MOSFET 40 V family offers an optimized solution for synchronous rectification in switched mode power supplies (SMPS) in servers, desktop PCs, wireless and quick chargers. The improved performance in on-state resistance ($R_{DS(on)}$) and figure of merits (FOM - $R_{DS(on)} \times Q_g$ and Q_{gd}) yields an efficiency improvement, allowing easier thermal design and less paralleling, leading to system cost reduction. In addition, the best-in-class $R_{DS(on)}$ makes these devices suitable for ORing circuits.

Infineon's market-leading OptiMOS™ 6 power MOSFETs 40 V are available in two different packages:

- > SuperSO8 – 5 x 6 mm with $R_{DS(on)}$ ranging from 5.9 m Ω down to 0.7 m Ω
- > PQFN 3x3 – 3.3 x 3.3 mm with $R_{DS(on)}$ ranging from 6.3 m Ω down to 1.8 m Ω



SMPS application: synchronous rectification

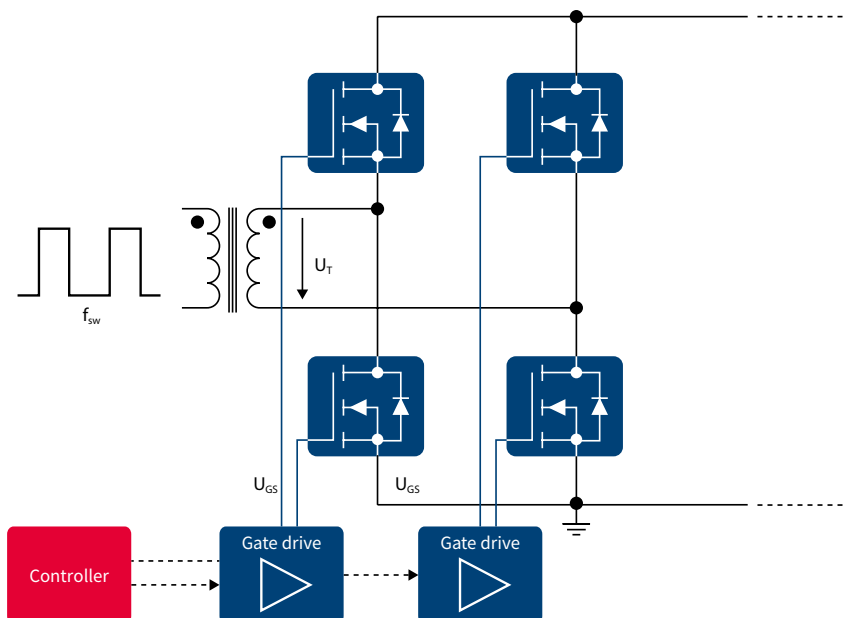

Lowest $R_{DS(on)}$ and Q_g enabling high efficiency over a wide load range in SMPS applications

In SMPS applications, OptiMOS™ 6 is the perfect solution for high efficiency over a wide range of output power, avoiding the trade-off between low and high load conditions.

At the low output power range, where switching losses due to parasitic capacitance in the MOSFET are dominating, OptiMOS™ 6 power MOSFET BSC010N04LS6 achieves the same efficiency as the OptiMOS™ 5 power MOSFET BSC014N04LS at 40% lower $R_{DS(on)}$.

Moreover, compared to the OptiMOS™ 5 40 V 1.0 m Ω power MOSFET, the OptiMOS™ 6 generation achieves lower switching losses at high load with the same $R_{DS(on)}$. This combination leads to an overall efficiency optimization in low and high load operating points.

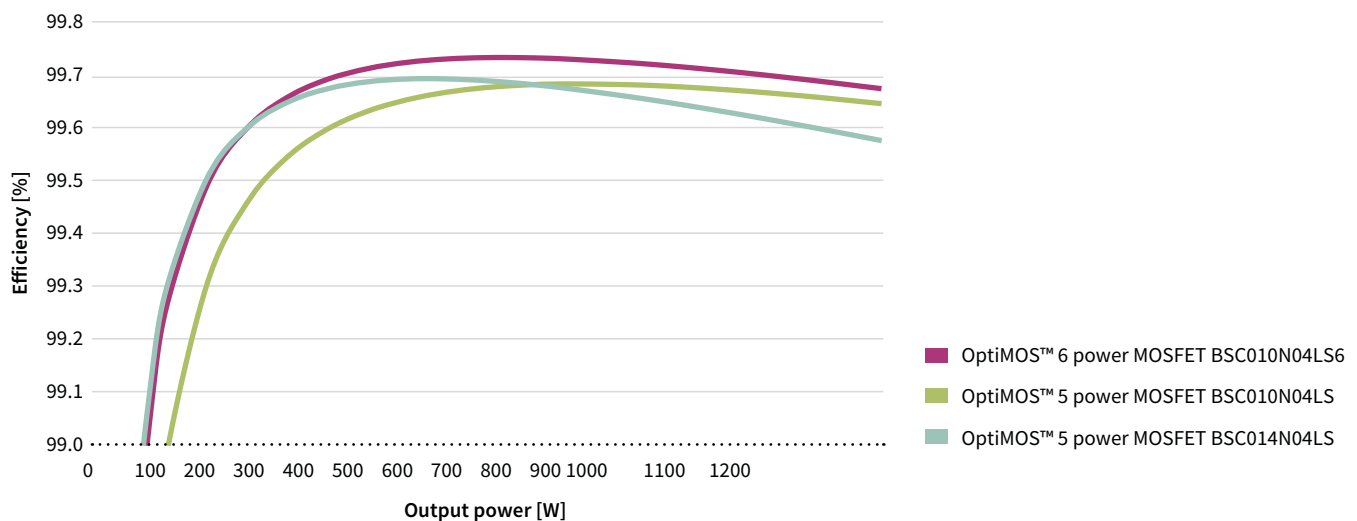

OptiMOST™ and StrongIRFET™ 20 V (super) logic level



$R_{DS(on)}$ max @ $V_{GS}=10$ V [mΩ]	TO-252 (DPAK)	DirectFET™	PQFN 2 x 2	PQFN 3.3 x 3.3	SuperSO8	SO-8	SOT-23
< 1		IRL6283MTRPBF $R_{DS(on)}=0.65$ mΩ			IRFH6200TRPBF $R_{DS(on)}=0.99$ mΩ		
2-4	IRLR6225TRPBF $R_{DS(on)}=4.0$ mΩ	IRL6297SDTRPBF** $R_{DS(on)}=3.8$ mΩ; dual			BSC026N02KS G $R_{DS(on)}=2.6$ mΩ IRLH6224TRPBF $R_{DS(on)}=3.0$ mΩ	IRF6201TRPBF $R_{DS(on)}=2.45$ mΩ	
4-10					BSC046N02KS G $R_{DS(on)}=4.6$ mΩ	IRF3717 $R_{DS(on)}=4.4$ mΩ	
> 10			IRLHS6242TRPBF $R_{DS(on)}=11.7$ mΩ IRLHS6276TRPBF** $R_{DS(on)}=45.0$ mΩ; dual				IRLML6244 ¹⁾ *** $R_{DS(on)}=21$ mΩ IRLML6246 ¹⁾ *** $R_{DS(on)}=46$ mΩ

OptiMOST™ and StrongIRFET™ 25 V logic level



$R_{DS(on)}$ max @ $V_{GS}=10$ V [mΩ]	DirectFET™	PQFN 2 x 2	PQFN 3.3 x 3.3	SuperSO8	SO-8	SOT-23
< 1	IRF6718L2TRPBF $R_{DS(on)}=0.7$ mΩ BSB008NE2LX $R_{DS(on)}=0.8$ mΩ		BSZ009NE2LS5 ²⁾ $R_{DS(on)}=0.9$ mΩ	BSC009NE2LS $R_{DS(on)}=0.9$ mΩ BSC009NE2LS5 $R_{DS(on)}=0.9$ mΩ BSC009NE2LS51** $R_{DS(on)}=0.95$ mΩ		
1-2	IRF6898MTRPBF** $R_{DS(on)}=1.1$ mΩ BSB012NE2LX1** $R_{DS(on)}=1.2$ mΩ IRF6717MTRPBF $R_{DS(on)}=1.25$ mΩ IRF6894MTRPBF** $R_{DS(on)}=1.3$ mΩ BSB013NE2LX1** $R_{DS(on)}=1.3$ mΩ IRF6797MTRPBF** $R_{DS(on)}=1.4$ mΩ IRF6716M $R_{DS(on)}=1.6$ mΩ IRF6715MTRPBF $R_{DS(on)}=1.6$ mΩ IRF6893MTRPBF** $R_{DS(on)}=1.6$ mΩ IRF6892STRPBF** $R_{DS(on)}=1.7$ mΩ IRF6795MTRPBF** $R_{DS(on)}=1.8$ mΩ		BSZ010NE2LS5 ²⁾ $R_{DS(on)}=1.0$ mΩ BSZ011NE2LS5 ²⁾ $R_{DS(on)}=1.1$ mΩ BSZ013NE2LS51** $R_{DS(on)}=1.3$ mΩ BSZ014NE2LS5IF *** $R_{DS(on)}=1.45$ mΩ BSZ017NE2LS51** $R_{DS(on)}=1.7$ mΩ BSZ018NE2LS $R_{DS(on)}=1.8$ mΩ BSZ018NE2LS1** $R_{DS(on)}=1.8$ mΩ	BSC010NE2LS $R_{DS(on)}=1.0$ mΩ BSC010NE2LS1** $R_{DS(on)}=1.05$ mΩ BSC014NE2LS1** $R_{DS(on)}=1.4$ mΩ IRFH5250D $R_{DS(on)}=1.4$ mΩ BSC015NE2LS51** $R_{DS(on)}=1.5$ mΩ BSC018NE2LS $R_{DS(on)}=1.8$ mΩ BSC018NE2LS1** $R_{DS(on)}=1.8$ mΩ		
2-4	IRF6714MTRPBF $R_{DS(on)}=2.1$ mΩ BSF030NE2LQ $R_{DS(on)}=3.0$ mΩ BSF035NE2LQ $R_{DS(on)}=3.5$ mΩ IRF6811STRPBF** $R_{DS(on)}=3.7$ mΩ		BSZ031NE2LS5 $R_{DS(on)}=3.1$ mΩ BSZ033NE2LS5 $R_{DS(on)}=3.3$ mΩ BSZ036NE2LS $R_{DS(on)}=3.6$ mΩ BSZ037NE2LS5 ²⁾ RDS(on)= 3.7mΩ BSZ039NE2LS5 ²⁾ $R_{DS(on)}=3.9$ mΩ	BSC024NE2LS $R_{DS(on)}=2.4$ mΩ BSC026NE2LS5 $R_{DS(on)}=2.6$ mΩ BSC032NE2LS $R_{DS(on)}=3.2$ mΩ	IRF8252 $R_{DS(on)}=2.7$ mΩ	
4-10	IRF6802SD $R_{DS(on)}=4.2$ mΩ IRF6710S2TRPBF $R_{DS(on)}=4.5$ mΩ IRF6712STRPBF $R_{DS(on)}=4.9$ mΩ IRF6810STRPBF** $R_{DS(on)}=5.2$ mΩ		IRFHM8228TRPBF $R_{DS(on)}=5.2$ mΩ BSZ060NE2LS $R_{DS(on)}=6.0$ mΩ IRFHM8235TRPBF $R_{DS(on)}=7.7$ mΩ	BSC050NE2LS $R_{DS(on)}=5.0$ mΩ		
> 10		IRFHS8242 $R_{DS(on)}=13$ mΩ				IRFML8244 $R_{DS(on)}=24$ mΩ

www.infineon.com/powermosfet-12V-300V

* Optimized for resonant applications (e.g. LLC converter)

** Monolithically integrated Schottky-like diode

*** $R_{DS(on)}$ max @ $V_{GS}=4.5$ V

¹⁾ 2.5 V_{GS} capable

²⁾ Coming soon



OptiMOS™ and StrongIRFET™ 25 V/30 V in Power Stage 3x3 and 5x6



Part number	Package	Monolithically integrated Schottky like diode	BV _{DSS} [V]	R _{DS(on), max.} [mΩ] @ V _{GS} =4.5 V max.		Q _g [nC] @ V _{GS} =4.5 V typ.	
				High-side	Low-side	High-side	Low-side
BSZ0910ND	TISON 3 x 3	–	30	13	13	4.0	4.0
BSZ0909ND	TISON 3 x 3	–	30	25	25	1.8	1.8
BSC0910NDI	TISON 5 x 6	✓	25	5.9	1.6	7.7	25.0
BSC0911ND	TISON 5 x 6	–	25	4.8	1.7	7.7	25.0
BSC0921NDI	TISON 5 x 6	✓	30	7.0	2.1	5.8	21.0
BSC0923NDI	TISON 5 x 6	✓	30	7.0	3.7	5.2	12.2
BSC0924NDI	TISON 5 x 6	✓	30	7.0	5.2	5.2	8.6
BSC0925ND	TISON 5 x 6	–	30	6.4	6.4	5.2	6.7

OptiMOS™ and StrongIRFET™ 25 V/30 V in Power Block 5x6 and 5x4



Part number	Package	Monolithically integrated Schottky like diode	BV _{DSS} [V]	R _{DS(on), max.} [mΩ] @ V _{GS} =4.5 V max.		Q _g [nC] @ V _{GS} =4.5 V typ.	
				High-side	Low-side	High-side	Low-side
BSG0810NDI	TISON 5 x 6	✓	25	4.0	1.2	5.6	16.0
BSG0811ND	TISON 5 x 6	–	25	4.0	1.1	5.6	20.0
BSG0813NDI	TISON 5 x 6	✓	25	4.0	1.7	5.6	12.0
IRFH4257DTRPBF	PQFN 5 x 4	✓	25	4.7	1.8	9.7	23.0

OptiMOST™ and StrongIRFET™ 30 V logic level



$R_{DS(on), max.}$ @ $V_{GS}=10\text{ V}$ [mΩ]	TO-252 (DPAK)	TO-263 (D ² PAK)	TO-263 (D ² PAK 7-pin)	TO-220
<1			IPB009N03L G $R_{DS(on)}=0.95\text{ m}\Omega$	
1-2		IRLS3813TRLPBF $R_{DS(on)}=1.95\text{ m}\Omega$		IRLB3813PBF $R_{DS(on)}=1.95\text{ m}\Omega$
2-4	IRLR8743TRPBF $R_{DS(on)}=3.1\text{ m}\Omega$			IRLB8314PBF $R_{DS(on)}=2.4\text{ m}\Omega$
	IPD031N03L G $R_{DS(on)}=3.1\text{ m}\Omega$			IRL3713PBF $R_{DS(on)}=3.0\text{ m}\Omega$
		IPB034N03L G $R_{DS(on)}=3.4\text{ m}\Omega$		IRLB8743PBF $R_{DS(on)}=3.2\text{ m}\Omega$
4-10	IPD040N03L G $R_{DS(on)}=4.0\text{ m}\Omega$			IPP034N03L G $R_{DS(on)}=3.4\text{ m}\Omega$
	IPD050N03L G $R_{DS(on)}=5.0\text{ m}\Omega$	IPB042N03L G $R_{DS(on)}=4.2\text{ m}\Omega$		IPP042N03L G $R_{DS(on)}=4.2\text{ m}\Omega$
	IRLR8726TRPBF $R_{DS(on)}=5.8\text{ m}\Omega$	IPB055N03L G $R_{DS(on)}=5.5\text{ m}\Omega$		IRLB8748PBF $R_{DS(on)}=4.8\text{ m}\Omega$
	IPD060N03L G $R_{DS(on)}=6.0\text{ m}\Omega$	IPB065N03L G $R_{DS(on)}=6.5\text{ m}\Omega$		IPP055N03L G $R_{DS(on)}=5.5\text{ m}\Omega$
	IPD075N03L G $R_{DS(on)}=7.5\text{ m}\Omega$	IPB080N03L G $R_{DS(on)}=8.0\text{ m}\Omega$		IRL8113PBF $R_{DS(on)}=6.0\text{ m}\Omega$
	IRLR8729TRPBF $R_{DS(on)}=8.9\text{ m}\Omega$			IRLB8721PBF $R_{DS(on)}=8.7\text{ m}\Omega$
	IPD090N03L G $R_{DS(on)}=9.0\text{ m}\Omega$			
10-25	IPD135N03L G $R_{DS(on)}=13.5\text{ m}\Omega$			
	IRLR3103 $R_{DS(on)}=19.0\text{ m}\Omega$			

OptiMOST™ and StrongIRFET™ 30 V logic level



$R_{DS(on), max.}$ @ $V_{GS}=10\text{ V}$ [mΩ]	Bare die ($R_{DS(on)}$ typ.)	DirectFET™	PQFN 3.3 x 3.3	SuperSO8	TO-Leadless
<1					IPT004N03L $R_{DS(on)}=0.4\text{ m}\Omega$
1-2				IRFH8303TRPBF $R_{DS(on)}=1.1\text{ m}\Omega$	
				BSC011N03LS $R_{DS(on)}=1.1\text{ m}\Omega$	
				BSC011N03LSI** $R_{DS(on)}=1.1\text{ m}\Omega$	
				BSC011N03LST $R_{DS(on)}=1.1\text{ m}\Omega$	
				IRFH8307TRPBF $R_{DS(on)}=1.3\text{ m}\Omega$	
		IRF8301MTRPBF $R_{DS(on)}=1.5\text{ m}\Omega$		BSC0500NSI** $R_{DS(on)}=1.3\text{ m}\Omega$	
			BSZ0500NSI** $R_{DS(on)}=1.5\text{ m}\Omega$	BSC014N03LS G $R_{DS(on)}=1.4\text{ m}\Omega$	
		IRF8302MTRPBF** $R_{DS(on)}=1.8\text{ m}\Omega$	BSZ019N03LS $R_{DS(on)}=1.9\text{ m}\Omega$	BSC0901NS $R_{DS(on)}=1.9\text{ m}\Omega$	
		BSZ0901NS $R_{DS(on)}=2.0\text{ m}\Omega$	BSC0501NSI** $R_{DS(on)}=1.9\text{ m}\Omega$		
	IPC055N03L3*** $R_{DS(on)}=2.7\text{ m}\Omega$		BSZ0501NSI** $R_{DS(on)}=2.0\text{ m}\Omega$	BSC0901NSI** $R_{DS(on)}=2.0\text{ m}\Omega$	

www.infineon.com/powermosfet-12V-300V

www.infineon.com/baredie

** Monolithically integrated Schottky-like diode

*** $R_{DS(on)}$ typ. @ $V_{GS}=4.5\text{ V}$

OptiMOS™ and StrongIRFET™ 30 V logic level



$R_{DS(on), max.}$ @ $V_{GS}=10\text{ V}$ [mΩ]	Bare die ($R_{DS(on)}$ typ.)	DirectFET™	PQFN 3.3 x 3.3	SuperSO8	SO-8	SO-8 Dual	PQFN 2 x 2
2-4		IRF8304MTRPBF $R_{DS(on)}=2.2\text{ m}\Omega$	BSZ0901NSI** $R_{DS(on)}=2.1\text{ m}\Omega$	BSC020N03LS G $R_{DS(on)}=2.0\text{ m}\Omega$			
	IPC042N03L3**** $R_{DS(on)}=3.7\text{ m}\Omega$		IRLHM620TRPBF $R_{DS(on)}=2.5\text{ m}\Omega$	BSC0502NSI** $R_{DS(on)}=2.4\text{ m}\Omega$			
		IRF8306MTRPBF** $R_{DS(on)}=2.5\text{ m}\Omega$	BSZ0902NS $R_{DS(on)}=2.6\text{ m}\Omega$	BSC025N03LS G $R_{DS(on)}=2.5\text{ m}\Omega$			
				BSC0902NS $R_{DS(on)}=2.6\text{ m}\Omega$			
				IRF8252TRPBF $R_{DS(on)}=2.7\text{ m}\Omega$			
			BSZ0902NSI** $R_{DS(on)}=2.8\text{ m}\Omega$	BSC0902NSI** $R_{DS(on)}=2.8\text{ m}\Omega$	IRF8788TRPBF $R_{DS(on)}=2.8\text{ m}\Omega$		
			BSZ0502NSI** $R_{DS(on)}=2.8\text{ m}\Omega$	IRFH8316TRPBF $R_{DS(on)}=2.95\text{ m}\Omega$			
				BSC030N03LS G $R_{DS(on)}=3.0\text{ m}\Omega$			
			BSZ0503NSI** $R_{DS(on)}=3.4\text{ m}\Omega$	IRFH8318TRPBF $R_{DS(on)}=3.1\text{ m}\Omega$			
			IRLHM630**** $R_{DS(on)}=3.5\text{ m}\Omega$	BSC0503NSI** $R_{DS(on)}=3.2\text{ m}\Omega$	IRF7862TRPBF $R_{DS(on)}=3.3\text{ m}\Omega$		
			BSZ035N03LS G $R_{DS(on)}=3.5\text{ m}\Omega$	BSC034N03LS G $R_{DS(on)}=3.4\text{ m}\Omega$	IRF8734TRPBF $R_{DS(on)}=3.5\text{ m}\Omega$		
			IRFHM830 $R_{DS(on)}=3.8\text{ m}\Omega$	BSC0504NSI** $R_{DS(on)}=3.7\text{ m}\Omega$			
		BSZ0904NSI** $R_{DS(on)}=4.0\text{ m}\Omega$	BSC0904NSI** $R_{DS(on)}=3.7\text{ m}\Omega$				
4-10			IRFHM830D $R_{DS(on)}=4.3\text{ m}\Omega$	IRFH8324TRPBF $R_{DS(on)}=4.1\text{ m}\Omega$			
			BSZ0506NS $R_{DS(on)}=4.4\text{ m}\Omega$	BSC042N03LS G $R_{DS(on)}=4.2\text{ m}\Omega$			
			IRFHM8326TRPBF $R_{DS(on)}=4.7\text{ m}\Omega$	BSC0906NS $R_{DS(on)}=4.5\text{ m}\Omega$			
				IRFH8321TRPBF $R_{DS(on)}=4.9\text{ m}\Omega$			
	IPC028N03L3 $R_{DS(on)}=5.0\text{ m}\Omega$		BSZ050N03LS G $R_{DS(on)}=5.0\text{ m}\Omega$	IRFH8325TRPBF $R_{DS(on)}=5.0\text{ m}\Omega$	IRF8736TRPBF $R_{DS(on)}=4.8\text{ m}\Omega$		
			BSZ058N03LS G $R_{DS(on)}=5.8\text{ m}\Omega$	BSC050N03LS G $R_{DS(on)}=5.0\text{ m}\Omega$			
	IPC022N03L3 $R_{DS(on)}=5.3\text{ m}\Omega$		IRFH8329TRPBF $R_{DS(on)}=6.1\text{ m}\Omega$	BSC052N03LS $R_{DS(on)}=5.2\text{ m}\Omega$			
			BSZ065N03LS $R_{DS(on)}=6.5\text{ m}\Omega$	BSC057N03LS G $R_{DS(on)}=5.7\text{ m}\Omega$			
		IRF8327S2 $R_{DS(on)}=7.3\text{ m}\Omega$	IRFH8330TRPBF $R_{DS(on)}=6.6\text{ m}\Omega$	IRFH8330TRPBF $R_{DS(on)}=6.6\text{ m}\Omega$			
			BSZ0994NS $R_{DS(on)}=7.0\text{ m}\Omega$	BSC080N03LS G $R_{DS(on)}=8.0\text{ m}\Omega$			
			IRFHM831 $R_{DS(on)}=7.8\text{ m}\Omega$	IRFH8334TRPBF $R_{DS(on)}=9.0\text{ m}\Omega$	IRF8721TRPBF $R_{DS(on)}=8.5\text{ m}\Omega$		
			BSZ088N03LS G $R_{DS(on)}=8.8\text{ m}\Omega$	BSC090N03LS G $R_{DS(on)}=9.0\text{ m}\Omega$	IRF8714TRPBF $R_{DS(on)}=8.7\text{ m}\Omega$		
		IRFHM8334TRPBF $R_{DS(on)}=9.0\text{ m}\Omega$	BSC0909NS $R_{DS(on)}=9.2\text{ m}\Omega$				
		BSZ100N03LS G $R_{DS(on)}=10.0\text{ m}\Omega$					
10-63	IPC014N03L3 $R_{DS(on)}=10.3\text{ m}\Omega$		BSZ0909NS $R_{DS(on)}=12.0\text{ m}\Omega$	BSC120N03LS G $R_{DS(on)}=12.0\text{ m}\Omega$	IRF8707TRPBF $R_{DS(on)}=11.9\text{ m}\Omega$	IRF7907TRPBF $R_{DS(on)}=11.8\text{ m}\Omega+16.4\text{ m}\Omega$	IRLHS6342*** $R_{DS(on)}=16\text{ m}\Omega$
			IRFHM8337TRPBF $R_{DS(on)}=12.4\text{ m}\Omega$	IRFH8337TRPBF $R_{DS(on)}=12.8\text{ m}\Omega$	IRL6342 ¹⁾ *** $R_{DS(on)}=14.6\text{ m}\Omega$	IRF8513TRPBF $R_{DS(on)}=2.7\text{ m}\Omega+15.5\text{ m}\Omega$	IRFHS8342 $R_{DS(on)}=16\text{ m}\Omega$
			BSZ130N03LS G $R_{DS(on)}=13.0\text{ m}\Omega$		IRL6372 ¹⁾ *** $R_{DS(on)}=18\text{ m}\Omega; \text{dual}$	IRF8313TRPBF $R_{DS(on)}=15.5\text{ m}\Omega+15.5\text{ m}\Omega$	IRLHS6376*** $R_{DS(on)}=63\text{ m}\Omega; \text{dual}$
			IRFHM8363TRPBF $R_{DS(on)}=14.9\text{ m}\Omega$			IRF7905TRPBF $R_{DS(on)}=17.1\text{ m}\Omega+21.8\text{ m}\Omega$	
2 x 7.2				BSC072N03LD G $R_{DS(on)}=7.2\text{ m}\Omega$			
2 x 15				BSC150N03LD G $R_{DS(on)}=15.0\text{ m}\Omega$			

www.infineon.com/powermosfet-12V-300V

1) 2.5 V_{GS} capable

** Monolithically integrated Schottky-like diode

*** $R_{DS(on)}$ max @ $V_{GS}=4.5\text{ V}$

**** $R_{DS(on)}$ typ. @ $V_{GS}=4.5\text{ V}$

OptiMOS™ and StrongIRFET™ 30 V logic level 5 V optimized

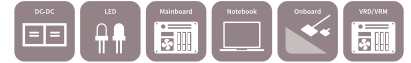

$R_{DS(on), max.}$ @ $V_{GS}=10\text{ V}$ [mΩ]	PQFN 3.3 x 3.3	SuperSO8	SO-8	SO-8 Dual	SOT-23	TSOP-6
1-2		BSC014N03MS G $R_{DS(on)}=1.4\text{ m}\Omega$				
		BSC016N03MS G $R_{DS(on)}=1.6\text{ m}\Omega$				
		BSC020N03MS G $R_{DS(on)}=2.0\text{ m}\Omega$				
2-4		BSC025N03MS G $R_{DS(on)}=2.5\text{ m}\Omega$	BSO033N03MS G $R_{DS(on)}=3.3\text{ m}\Omega$			
	BSZ035N03MS G $R_{DS(on)}=3.5\text{ m}\Omega$	BSC030N03MS G $R_{DS(on)}=3.0\text{ m}\Omega$	BSO040N03MS G $R_{DS(on)}=4.0\text{ m}\Omega$			
4-10		BSC042N03MS G $R_{DS(on)}=4.2\text{ m}\Omega$				
	BSZ050N03MS G $R_{DS(on)}=5.0\text{ m}\Omega$	BSC050N03MS G $R_{DS(on)}=5.0\text{ m}\Omega$				
		BSC057N03MS G $R_{DS(on)}=5.7\text{ m}\Omega$				
	BSZ058N03MS G $R_{DS(on)}=5.8\text{ m}\Omega$	BSC080N03MS G $R_{DS(on)}=8.0\text{ m}\Omega$				
	BSZ088N03MS G $R_{DS(on)}=8.8\text{ m}\Omega$	BSC090N03MS G $R_{DS(on)}=9.0\text{ m}\Omega$				
	BSZ100N03MS G $R_{DS(on)}=10.0\text{ m}\Omega$	BSC100N03MS G $R_{DS(on)}=10.0\text{ m}\Omega$				
>10	BSZ130N03MS G $R_{DS(on)}=13.0\text{ m}\Omega$	BSC120N03MS G $R_{DS(on)}=12.0\text{ m}\Omega$	BSO110N03MS G $R_{DS(on)}=11.0\text{ m}\Omega$		IRLML0030 $R_{DS(on)}=27\text{ m}\Omega$	IRLTS6342*** $R_{DS(on)}=14.6\text{ m}\Omega$
					IRLML6344 ¹⁾ *** $R_{DS(on)}=29\text{ m}\Omega$	IRF7S8342 $R_{DS(on)}=19\text{ m}\Omega$
					IRLML6346 ¹⁾ *** $R_{DS(on)}=63\text{ m}\Omega$	
					IRLML2030 $R_{DS(on)}=100\text{ m}\Omega$	
2 x 15				BSO150N03MD G $R_{DS(on)}=15.0\text{ m}\Omega$		
2 x 22				BSO220N03MD G $R_{DS(on)}=22.0\text{ m}\Omega$		



OptiMOS™ and StrongIRFET™ 40 V normal level

$R_{DS(on), max.}$ @ $V_{GS}=10\text{ V}$ [mΩ]	TO-252 (DPAK)	TO-263 (D ² PAK)	TO-263 (D ² PAK 7-pin)	TO-220	TO-247	Bare die ($R_{DS(on)}$ typ.)	DirectFET™	PQFN 3.3 x 3.3	SuperSO8	TO-220 FullPAK
<1			IRFS7430TRL7PP $R_{DS(on)}=0.75\text{ m}\Omega$			IPC218N04N3 $R_{DS(on)}=0.9\text{ m}\Omega$				
1-2		IRFS7430TRLPBF $R_{DS(on)}=1.3\text{ m}\Omega$	IRFS7434TRL7PP $R_{DS(on)}=1.0\text{ m}\Omega$	IRFB7430PBF $R_{DS(on)}=1.3\text{ m}\Omega$	IRFP7430PBF $R_{DS(on)}=1.3\text{ m}\Omega$	IPC171N04N $R_{DS(on)}=1.1\text{ m}\Omega$	IRF7739L1TRPBF $R_{DS(on)}=1.0\text{ m}\Omega$		IRFH7084TRPBF $R_{DS(on)}=1.25\text{ m}\Omega$	
		IPB015N04N G $R_{DS(on)}=1.5\text{ m}\Omega$	IPB011N04N G $R_{DS(on)}=1.1\text{ m}\Omega$	IPP015N04N G $R_{DS(on)}=1.5\text{ m}\Omega$			IRF7480MTRPBF $R_{DS(on)}=1.2\text{ m}\Omega$		IRFH7004TRPBF $R_{DS(on)}=1.4\text{ m}\Omega$	
		IRFS3004 $R_{DS(on)}=1.75\text{ m}\Omega$	IRFS3004-7P $R_{DS(on)}=1.25\text{ m}\Omega$				IRF7946TRPBF $R_{DS(on)}=1.4\text{ m}\Omega$		BSC017N04NS G $R_{DS(on)}=1.7\text{ m}\Omega$	
		IRFS7434TRLPBF $R_{DS(on)}=1.6\text{ m}\Omega$	IRFS7437TRL7PP $R_{DS(on)}=1.4\text{ m}\Omega$	IRFB7434PBF $R_{DS(on)}=1.6\text{ m}\Omega$			BSB015N04NX3 G $R_{DS(on)}=1.5\text{ m}\Omega$		IRF40H210 $R_{DS(on)}=1.7\text{ m}\Omega$	
		IRFS7437TRLPBF $R_{DS(on)}=1.8\text{ m}\Omega$	IPB020N04N G $R_{DS(on)}=2.0\text{ m}\Omega$	IRFB7437PBF $R_{DS(on)}=2.0\text{ m}\Omega$			IRF40DM229 $R_{DS(on)}=1.85\text{ m}\Omega$		BSC019N04NS G $R_{DS(on)}=1.9\text{ m}\Omega$	
2-4	IRFR7440TRPBF $R_{DS(on)}=2.4\text{ m}\Omega$			IPP023N04N G $R_{DS(on)}=2.3\text{ m}\Omega$			IRF7483MTRPBF $R_{DS(on)}=2.3\text{ m}\Omega$		IRFH7440TRPBF $R_{DS(on)}=2.4\text{ m}\Omega$	
	IRFR7446TRPBF $R_{DS(on)}=3.9\text{ m}\Omega$	IRFS7440TRLPBF $R_{DS(on)}=2.5\text{ m}\Omega$		IRFB7440PBF $R_{DS(on)}=2.5\text{ m}\Omega$					BSC030N04NS G $R_{DS(on)}=3.0\text{ m}\Omega$	
		IRF1404S $R_{DS(on)}=4.0\text{ m}\Omega$		IRFB7446PBF $R_{DS(on)}=3.3\text{ m}\Omega$					IRFH7446TRPBF $R_{DS(on)}=3.3\text{ m}\Omega$	
4-10				IPP041N04N G $R_{DS(on)}=4.1\text{ m}\Omega$					BSC054N04NS G $R_{DS(on)}=5.4\text{ m}\Omega$	IPA041N04N G $R_{DS(on)}=4.1\text{ m}\Omega$
	IRF40R207 $R_{DS(on)}=5.1\text{ m}\Omega$			IRF40B207 $R_{DS(on)}=4.5\text{ m}\Omega$						
				IPP048N04N G $R_{DS(on)}=4.8\text{ m}\Omega$						
>10							BSZ105N04NS G $R_{DS(on)}=10.5\text{ m}\Omega$			
								BSZ165N04NS G $R_{DS(on)}=16.5\text{ m}\Omega$		

www.infineon.com/powermosfet-12V-300V

1) 2.5 V_{GS} capable
*** $R_{DS(on)}$ max @ $V_{GS}=4.5\text{ V}$

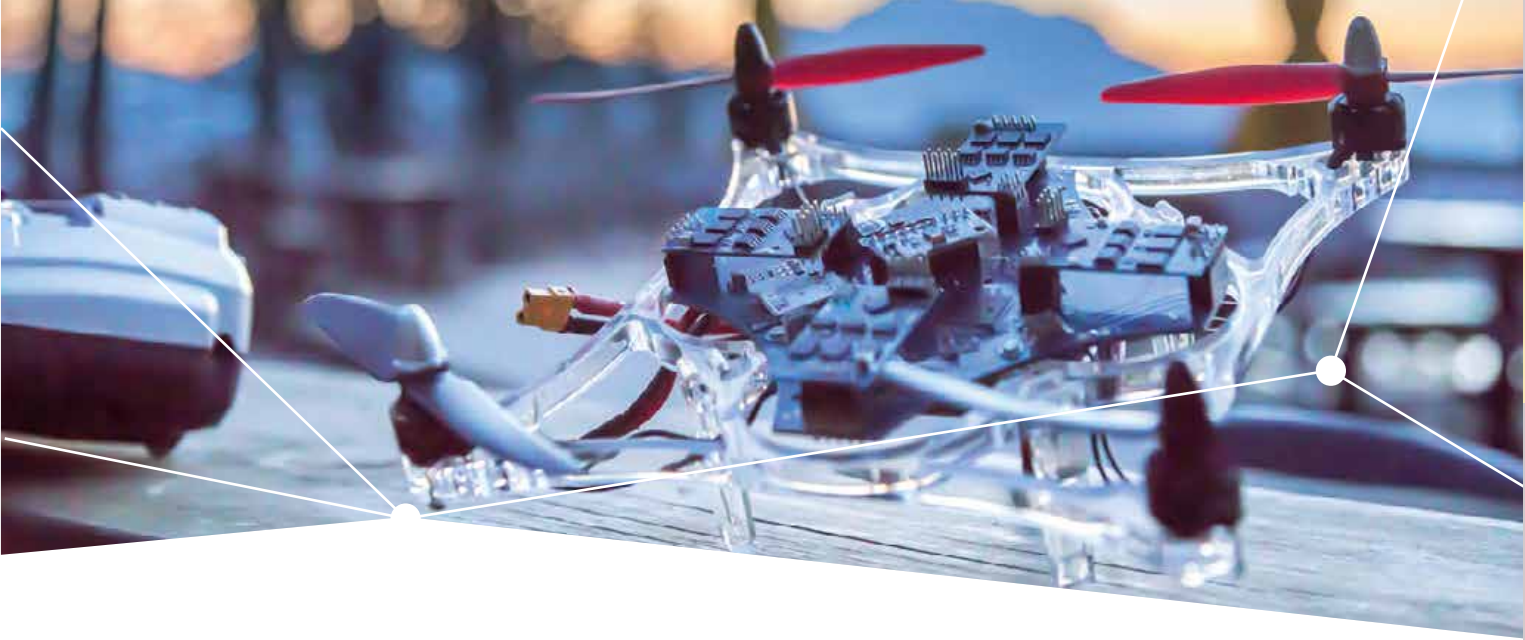

Applications
20-300 V MOSFETs
500-950 V MOSFETs
WBG semiconductors
Discrete IGBTs
Power ICS
Gate driver ICS
Microcontroller ICS
Microcontrollers
XENSIV™ sensors
Packages



OptiMOS™ and StrongIRFET™ 40 V logic level

$R_{DS(on), max.}$ @ $V_{GS}=10\text{ V}$ [mΩ]	TO-252 (DPAK)	TO-263 (D ² PAK)	TO-263 (D ² PAK 7-pin)	TO-220	TO-247	DirectFET™	PQFN 3.3 x 3.3	SuperSO8	TO-Leadless
<1			IRL40SC228 $R_{DS(on)}=0.65\text{ m}\Omega$						IRL40T209 $R_{DS(on)}=0.8\text{ m}\Omega$
			IRL40SC209 $R_{DS(on)}=0.8\text{ m}\Omega$						
1-2		IPB015N04L G $R_{DS(on)}=1.5\text{ m}\Omega$	IPB011N04L G $R_{DS(on)}=1.1\text{ m}\Omega$	IRL40B209 $R_{DS(on)}=1.25\text{ m}\Omega$	IRLP3034PBF $R_{DS(on)}=1.7\text{ m}\Omega$	BSB014N04LX3 G $R_{DS(on)}=1.4\text{ m}\Omega$		BSC010N04LS $R_{DS(on)}=1.0\text{ m}\Omega$	
		IRLS3034TRLPBF $R_{DS(on)}=1.7\text{ m}\Omega$	IRLS3034TRL7P $R_{DS(on)}=1.4\text{ m}\Omega$	IRLB3034PBF $R_{DS(on)}=1.7\text{ m}\Omega$		IRL7486MTRPBF $R_{DS(on)}=1.4\text{ m}\Omega$		BSC010N04LS6 $R_{DS(on)}=1.0\text{ m}\Omega$	
		IRL40S212 $R_{DS(on)}=1.9\text{ m}\Omega$		IRL40B212 $R_{DS(on)}=1.9\text{ m}\Omega$				BSC010N04LST $R_{DS(on)}=1.0\text{ m}\Omega$	
								BSC010N04LSI $R_{DS(on)}=1.05\text{ m}\Omega$	
								BSC010N04LSC * $R_{DS(on)}=1.05\text{ m}\Omega$	
								BSC014N04LST $R_{DS(on)}=1.4\text{ m}\Omega$	
								BSC014N04LS $R_{DS(on)}=1.4\text{ m}\Omega$	
								BSC014N04LSI $R_{DS(on)}=1.45\text{ m}\Omega$	
								BSC016N04LS G $R_{DS(on)}=1.6\text{ m}\Omega$	
								BSZ018N04LS6 $R_{DS(on)}=1.8\text{ m}\Omega$	BSC018N04LS G $R_{DS(on)}=1.8\text{ m}\Omega$
2-4				IRL40B215 $R_{DS(on)}=2.7\text{ m}\Omega$				BSC019N04LS $R_{DS(on)}=1.9\text{ m}\Omega$	
								BSC019N04LST $R_{DS(on)}=1.9\text{ m}\Omega$	
					IPP039N04L G $R_{DS(on)}=3.9\text{ m}\Omega$			BSC022N04LS $R_{DS(on)}=2.2\text{ m}\Omega$	
								BSC022N04LS6 $R_{DS(on)}=2.2\text{ m}\Omega$	
								BSC026N04LS $R_{DS(on)}=2.6\text{ m}\Omega$	
4-10								BSC027N04LS G $R_{DS(on)}=2.7\text{ m}\Omega$	
								BSC032N04LS $R_{DS(on)}=3.2\text{ m}\Omega$	
	IPD036N04L G $R_{DS(on)}=3.6\text{ m}\Omega$	IRL1404S $R_{DS(on)}=4.0\text{ m}\Omega$						BSC035N04LS G $R_{DS(on)}=3.5\text{ m}\Omega$	
	IRLR31142TRPBF $R_{DS(on)}=4.5\text{ m}\Omega$							BSC050N04LS G $R_{DS(on)}=5.0\text{ m}\Omega$	
								BSC059N04LS G $R_{DS(on)}=5.9\text{ m}\Omega$	
								BSC059N04LS6 $R_{DS(on)}=5.9\text{ m}\Omega$	
							BSZ097N04LS G $R_{DS(on)}=9.7\text{ m}\Omega$	BSC093N04LS G $R_{DS(on)}=9.3\text{ m}\Omega$	

www.infineon.com/powermosfet-12V-300V

3) Coming soon
* Increased creepage distance



OptiMOS™ and StrongIRFET™ 60 V normal level

$R_{DS(on),max}$ @ $V_{GS}=10V$ [mΩ]	TO-252 (DPAK)	TO-263 (D ² PAK)	TO-263 (D ² PAK 7-pin)	TO-262 (I ² PAK)	TO-220	TO-220 FullPAK	TO-247
1-2			IPB010N06N ²⁾ $R_{DS(on)}=1.0\text{ m}\Omega$				
			IRFS7530TRL7PP $R_{DS(on)}=1.4\text{ m}\Omega$				
			IPB014N06N ²⁾ $R_{DS(on)}=1.4\text{ m}\Omega$				
			IPB017N06N3 G $R_{DS(on)}=1.7\text{ m}\Omega$				
2-4	IPD025N06N ²⁾ $R_{DS(on)}=2.5\text{ m}\Omega$	IRFS7534TRL7PP $R_{DS(on)}=2.4\text{ m}\Omega$	IRFS7534TRL7PP $R_{DS(on)}=1.95\text{ m}\Omega$	IPI020N06N ²⁾ $R_{DS(on)}=2.0\text{ m}\Omega$	IRFB7530PBF $R_{DS(on)}=2.0\text{ m}\Omega$		IRFP7530PBF $R_{DS(on)}=2.0\text{ m}\Omega$
		IRFS3006 $R_{DS(on)}=2.5\text{ m}\Omega$		IPI024N06N3 G $R_{DS(on)}=2.4\text{ m}\Omega$	IRFB7534PBF $R_{DS(on)}=2.4\text{ m}\Omega$		
		IPB026N06N ²⁾ $R_{DS(on)}=2.6\text{ m}\Omega$			IPP024N06N3 G ²⁾ $R_{DS(on)}=2.4\text{ m}\Omega$		IRFP3006PBF $R_{DS(on)}=2.5\text{ m}\Omega$
		IPB029N06N3 G $R_{DS(on)}=2.9\text{ m}\Omega$		IPI029N06N ²⁾ $R_{DS(on)}=2.9\text{ m}\Omega$	IPP029N06N ²⁾ $R_{DS(on)}=2.9\text{ m}\Omega$	IPA029N06N ²⁾ $R_{DS(on)}=2.9\text{ m}\Omega$	IRFP3206PBF $R_{DS(on)}=3.0\text{ m}\Omega$
	IPD033N06N ²⁾ $R_{DS(on)}=3.3\text{ m}\Omega$	IRFS3206 $R_{DS(on)}=3.0\text{ m}\Omega$		IPI032N06N3 G $R_{DS(on)}=3.2\text{ m}\Omega$	IPP032N06N3 G $R_{DS(on)}=3.2\text{ m}\Omega$	IPA032N06N3 G $R_{DS(on)}=3.2\text{ m}\Omega$	
	IPD034N06N3 G $R_{DS(on)}=3.4\text{ m}\Omega$	IRFS7537TRL7PP $R_{DS(on)}=3.3\text{ m}\Omega$			IRFB7537PBF $R_{DS(on)}=3.3\text{ m}\Omega$		IRFP7537PBF $R_{DS(on)}=3.3\text{ m}\Omega$
	IPD038N06N3 G $R_{DS(on)}=3.8\text{ m}\Omega$	IPB037N06N3 G $R_{DS(on)}=3.7\text{ m}\Omega$			IPP040N06N3 G $R_{DS(on)}=4.0\text{ m}\Omega$		
		IRFS3306 $R_{DS(on)}=4.2\text{ m}\Omega$		IPI040N06N3 G $R_{DS(on)}=4.0\text{ m}\Omega$	IPP040N06N ²⁾ $R_{DS(on)}=4.0\text{ m}\Omega$	IPA040N06N ²⁾ $R_{DS(on)}=4.0\text{ m}\Omega$	
	IRFR7540TRPBF $R_{DS(on)}=4.8\text{ m}\Omega$	IRFS7540TRL7PP $R_{DS(on)}=5.1\text{ m}\Omega$			IRFB7540PBF $R_{DS(on)}=5.1\text{ m}\Omega$	IPA057N06N3 G $R_{DS(on)}=5.7\text{ m}\Omega$	
	IPD053N06N ²⁾ $R_{DS(on)}=5.3\text{ m}\Omega$	IPB054N06N3 G $R_{DS(on)}=5.4\text{ m}\Omega$			IPP057N06N3 G ²⁾ $R_{DS(on)}=5.7\text{ m}\Omega$		
4-10		IPB057N06N ²⁾ $R_{DS(on)}=5.7\text{ m}\Omega$			IRFB7545PBF $R_{DS(on)}=5.9\text{ m}\Omega$		
	IRFR7546TRPBF $R_{DS(on)}=7.9\text{ m}\Omega$	IRF1018ES $R_{DS(on)}=8.4\text{ m}\Omega$			IPP060N06N ²⁾ $R_{DS(on)}=6.0\text{ m}\Omega$	IPA060N06N ²⁾ $R_{DS(on)}=6.0\text{ m}\Omega$	
	IPD088N06N3 G $R_{DS(on)}=8.8\text{ m}\Omega$				IRF60B217 $R_{DS(on)}=9.0\text{ m}\Omega$	IPA093N06N3 G $R_{DS(on)}=9.3\text{ m}\Omega$	
	IRF60R217 $R_{DS(on)}=9.9\text{ m}\Omega$	IPB090N06N3 G $R_{DS(on)}=9.0\text{ m}\Omega$			IPP093N06N3 G $R_{DS(on)}=9.3\text{ m}\Omega$		
	>10	IRFS3806 $R_{DS(on)}=15.8\text{ m}\Omega$					



OptiMOS™ and StrongIRFET™ 60 V normal level

$R_{DS(on), max.}$ @ $V_{GS}=10\text{ V}$ [mΩ]	Bare die ($R_{DS(on) typ.}$)	DirectFET™	PQFN 3.3 x 3.3	SuperSO8	TO-Leadless
<1					IPT007N06N ²⁾ $R_{DS(on)}=0.7\text{ mΩ}$ IPT012N06N ²⁾ $R_{DS(on)}=1.2\text{ mΩ}$
1-2	IPC218N06N3 $R_{DS(on)}=1.3\text{ mΩ}$	IRF7749L1TRPBF $R_{DS(on)}=1.5\text{ mΩ}$		BSC012N06NS $R_{DS(on)}=1.2\text{ mΩ}$ BSC014N06NS ²⁾ $R_{DS(on)}=1.4\text{ mΩ}$ BSC014N06NST ²⁾ $R_{DS(on)}=1.45\text{ mΩ}$ BSC016N06NST ²⁾ $R_{DS(on)}=1.6\text{ mΩ}$ BSC016N06NS ²⁾ $R_{DS(on)}=1.6\text{ mΩ}$ BSC019N06NS ²⁾ $R_{DS(on)}=1.9\text{ mΩ}$	
		IRF7748L1TRPBF $R_{DS(on)}=2.2\text{ mΩ}$		BSC028N06NS ²⁾ $R_{DS(on)}=2.8\text{ mΩ}$ BSC028N06NST ²⁾ $R_{DS(on)}=2.8\text{ mΩ}$ BSC031N06NS3 G $R_{DS(on)}=3.1\text{ mΩ}$	
		BSB028N06NN3 G $R_{DS(on)}=2.8\text{ mΩ}$ IRF60DM206 $R_{DS(on)}=2.9\text{ mΩ}$		IRFH7085TRPBF $R_{DS(on)}=3.2\text{ mΩ}$ BSC034N06NS ²⁾ $R_{DS(on)}=3.4\text{ mΩ}$ BSC039N06NS ²⁾ $R_{DS(on)}=3.9\text{ mΩ}$	
		IRF7580MTRPBF $R_{DS(on)}=3.6\text{ mΩ}$ IRF6648 $R_{DS(on)}=7.0\text{ mΩ}$ IRF6674 $R_{DS(on)}=11.0\text{ mΩ}$		BSZ042N06NS ²⁾ $R_{DS(on)}=4.2\text{ mΩ}$ IRLH5036TRPBF $R_{DS(on)}=4.4\text{ mΩ}$ IRFH7545TRPBF $R_{DS(on)}=5.2\text{ mΩ}$	
4-10			BSZ068N06NS ²⁾ $R_{DS(on)}=6.8\text{ mΩ}$	BSC066N06NS ²⁾ $R_{DS(on)}=6.6\text{ mΩ}$ BSC076N06NS3 G $R_{DS(on)}=7.6\text{ mΩ}$ BSC097N06NS ²⁾ $R_{DS(on)}=9.7\text{ mΩ}$ BSC097N06NST ²⁾ $R_{DS(on)}=9.7\text{ mΩ}$	
			BSZ100N06NS ²⁾ $R_{DS(on)}=10.0\text{ mΩ}$	BSC097N06NS ²⁾ $R_{DS(on)}=9.7\text{ mΩ}$ BSC110N06NS3 G $R_{DS(on)}=11.0\text{ mΩ}$	
			BSZ110N06NS3 G $R_{DS(on)}=11.0\text{ mΩ}$		
>10					



OptiMOS™ and StrongIRFET™ 60 V logic level

$R_{DS(on), max.}$ @ $V_{GS}=10\text{ V}$ [mΩ]	TO-252 (DPAK)	TO-263 (D ² PAK)	TO-263 (D ² PAK 7-pin)	TO-262 (i ² PAK)	TO-220	Bare die ($R_{DS(on) typ.}$)	PQFN 2 x 2	PQFN 3.3 x 3.3	SuperSO8	SOT-23
1-2		IPB019N06L3 G $R_{DS(on)}=1.9\text{ mΩ}$	IPB016N06L3 G $R_{DS(on)}=1.6\text{ mΩ}$			IPC218N06L3 $R_{DS(on)}=1.2\text{ mΩ}$			BSC014N06LS5 $R_{DS(on)}=1.4\text{ mΩ}$	
		IRL60S216 $R_{DS(on)}=1.95\text{ mΩ}$		IRL60SL216 $R_{DS(on)}=1.95\text{ mΩ}$	IRL60B216 $R_{DS(on)}=1.9\text{ mΩ}$					
2-4		IRLS3036TRLPBF $R_{DS(on)}=2.4\text{ mΩ}$			IRLB3036PBF $R_{DS(on)}=2.4\text{ mΩ}$				BSC027N06LS5 $R_{DS(on)}=2.7\text{ mΩ}$	
	IPD031N06L3 G $R_{DS(on)}=3.1\text{ mΩ}$	IPB034N06L3 G $R_{DS(on)}=3.4\text{ mΩ}$			IPP037N06L3 G $R_{DS(on)}=3.7\text{ mΩ}$				BSC028N06LS3 G $R_{DS(on)}=2.8\text{ mΩ}$	
4-10	IPD048N06L3 G $R_{DS(on)}=4.8\text{ mΩ}$				IPP052N06L3 G $R_{DS(on)}=5.2\text{ mΩ}$			BSZ040N06LS5 $R_{DS(on)}=4.0\text{ mΩ}$	IRLH5036TRPBF $R_{DS(on)}=4.4\text{ mΩ}$	
	IRLR3636TRPBF $R_{DS(on)}=6.8\text{ mΩ}$							BSZ065N06LS5 $R_{DS(on)}=6.5\text{ mΩ}$	BSC065N06LS5 $R_{DS(on)}=6.5\text{ mΩ}$	
	IPD079N06L3 G $R_{DS(on)}=7.9\text{ mΩ}$	IPB081N06L3 G $R_{DS(on)}=8.1\text{ mΩ}$			IPI084N06L3 G $R_{DS(on)}=8.4\text{ mΩ}$	IPP084N06L3 G $R_{DS(on)}=8.4\text{ mΩ}$		BSZ067N06LS3 G $R_{DS(on)}=6.7\text{ mΩ}$	BSC067N06LS3 G $R_{DS(on)}=6.7\text{ mΩ}$	
								BSZ099N06LS5 $R_{DS(on)}=9.9\text{ mΩ}$	BSC094N06LS5 $R_{DS(on)}=9.4\text{ mΩ}$	
>10								BSZ100N06LS3 G $R_{DS(on)}=10.0\text{ mΩ}$	BSC100N06LS3 G $R_{DS(on)}=10.0\text{ mΩ}$	
	IPD350N06L G $R_{DS(on)}=35.0\text{ mΩ}$						IRL60HS118 $R_{DS(on)}=17.0\text{ mΩ}$		IRLML0060 $R_{DS(on)}=92\text{ mΩ}$ IRLML2060 $R_{DS(on)}=480\text{ mΩ}$	

www.infineon.com/powermosfet-12V-300V

2) 6 V rated ($R_{DS(on)}$ also specified @ $V_{GS} = 6\text{ V}$)
3) Coming soon



OptiMOS™ and StrongIRFET™ 75 V normal level

$R_{DS(on), max.}$ @ $V_{GS}=10\text{ V}$ [mΩ]	TO-252 (DPAK)	TO-263 (D ² PAK)	TO-263 (D ² PAK 7-pin)	TO-220	TO-247	Bare die ($R_{DS(on)}$ typ.)	DirectFET™	SuperSO8
1-2		IPB020NE7N3 G $R_{DS(on)}=2.0\text{ m}\Omega$	IRFS7730TRL7PP $R_{DS(on)}=2.0\text{ m}\Omega$		IRFP7718PBF $R_{DS(on)}=1.8\text{ m}\Omega$	IPC302NE7N3 $R_{DS(on)}=1.2\text{ m}\Omega$		
2-4		IRFS7730TRL7PP $R_{DS(on)}=2.6\text{ m}\Omega$		IPP023NE7N3 G $R_{DS(on)}=2.3\text{ m}\Omega$				
		IPB031NE7N3 G $R_{DS(on)}=3.1\text{ m}\Omega$	IRFS7734TRL7PP $R_{DS(on)}=3.05\text{ m}\Omega$	IRFB7730PBF $R_{DS(on)}=2.6\text{ m}\Omega$				BSC036NE7NS3 G $R_{DS(on)}=3.6\text{ m}\Omega$
		IRFS7734TRL7PP $R_{DS(on)}=3.5\text{ m}\Omega$		IPP034NE7N3 G $R_{DS(on)}=3.4\text{ m}\Omega$				
4-10		IPB049NE7N3 G $R_{DS(on)}=4.9\text{ m}\Omega$		IPP052NE7N3 G $R_{DS(on)}=5.2\text{ m}\Omega$				BSC042NE7NS3 G $R_{DS(on)}=4.2\text{ m}\Omega$
		IRFS7762TRL7PP $R_{DS(on)}=6.7\text{ m}\Omega$		IPP062NE7N3 G $R_{DS(on)}=6.2\text{ m}\Omega$			IRF7780MTRPBF $R_{DS(on)}=5.7\text{ m}\Omega$	
	IRFR7740TRPBF $R_{DS(on)}=7.2\text{ m}\Omega$			IRFB7740PBF $R_{DS(on)}=7.3\text{ m}\Omega$				
>10		IRFS7787TRL7PP $R_{DS(on)}=8.4\text{ m}\Omega$		IRFB7787PBF $R_{DS(on)}=8.4\text{ m}\Omega$				IRFH7787TRPBF $R_{DS(on)}=8.0\text{ m}\Omega$
	IRFR7746TRPBF $R_{DS(on)}=11.2\text{ m}\Omega$			IRFB7746PBF $R_{DS(on)}=10.6\text{ m}\Omega$			BSF450NE7NH3 ¹⁾ $R_{DS(on)}=45.0\text{ m}\Omega$	



OptiMOS™ and StrongIRFET™ 80 V normal level – logic level

$R_{DS(on), max.}$ @ $V_{GS}=10\text{ V}$ [mΩ]	TO-252 (DPAK)	TO-263 (D ² PAK)	TO-263 (D ² PAK 7-pin)	TO-262 (I ² PAK)	TO-220	TO-220 FullPAK	Bare die ($R_{DS(on)}$ typ.)	DirectFET™	PQFN 2 x 2	PQFN 3.3 x 3.3	SuperSO8	TO-Leadless
1-2		IPB017N08N5 $R_{DS(on)}=1.7\text{ m}\Omega$	IPB015N08N5 $R_{DS(on)}=1.5\text{ m}\Omega$				IPC302N08N3 $R_{DS(on)}=1.2\text{ m}\Omega$					IPT012N08N5 $R_{DS(on)}=1.2\text{ m}\Omega$
		IPB020N08N5 $R_{DS(on)}=2.0\text{ m}\Omega$	IPB019N08N3 G $R_{DS(on)}=1.9\text{ m}\Omega$		IPP020N08N5 $R_{DS(on)}=2.0\text{ m}\Omega$						BSC021N08NS5 $R_{DS(on)}=2.1\text{ m}\Omega$	
2-4		IPB024N08N5 $R_{DS(on)}=2.4\text{ m}\Omega$			IPP023N08N5 $R_{DS(on)}=2.3\text{ m}\Omega$						BSC025N08LS5 $R_{DS(on)}=2.5\text{ m}\Omega$	
		IPB025N08N3 G $R_{DS(on)}=2.5\text{ m}\Omega$	IPB030N08N3 G $R_{DS(on)}=3.0\text{ m}\Omega$		IPP027N08N5 $R_{DS(on)}=2.7\text{ m}\Omega$						BSC026N08NS5 $R_{DS(on)}=2.6\text{ m}\Omega$	
					IPP028N08N3 G $R_{DS(on)}=2.8\text{ m}\Omega$	IPA028N08N3 G $R_{DS(on)}=2.8\text{ m}\Omega$					BSC030N08NS5 $R_{DS(on)}=3.0\text{ m}\Omega$	IPT029N08N5 $R_{DS(on)}=2.9\text{ m}\Omega$
		IPB031N08N5 $R_{DS(on)}=3.1\text{ m}\Omega$			IPP034N08N5 $R_{DS(on)}=3.4\text{ m}\Omega$						BSC037N08NS5 $R_{DS(on)}=3.7\text{ m}\Omega$	
											BSC037N08NS5T $R_{DS(on)}=3.7\text{ m}\Omega$	
4-10		IPB035N08N3 G $R_{DS(on)}=3.5\text{ m}\Omega$		IPI037N08N3 G $R_{DS(on)}=3.7\text{ m}\Omega$	IPP037N08N3 G $R_{DS(on)}=3.7\text{ m}\Omega$	IPA037N08N3 G $R_{DS(on)}=3.7\text{ m}\Omega$					BSC040N08NS5 $R_{DS(on)}=4.0\text{ m}\Omega$	
	IPD046N08N5 $R_{DS(on)}=4.6\text{ m}\Omega$	IPB049N08N5 $R_{DS(on)}=4.9\text{ m}\Omega$			IPP052N08N5 $R_{DS(on)}=5.2\text{ m}\Omega$			BSB044N08NN3 G $R_{DS(on)}=4.4\text{ m}\Omega$			BSC047N08NS3 G $R_{DS(on)}=4.7\text{ m}\Omega$	
	IPD053N08N3 G $R_{DS(on)}=5.3\text{ m}\Omega$	IPB054N08N3 G $R_{DS(on)}=5.4\text{ m}\Omega$			IPP057N08N3 G $R_{DS(on)}=5.7\text{ m}\Omega$	IPA057N08N3 G $R_{DS(on)}=5.7\text{ m}\Omega$					BSC052N08NS5 $R_{DS(on)}=5.2\text{ m}\Omega$	
		IPB067N08N3 G $R_{DS(on)}=6.7\text{ m}\Omega$									BSZ070N08LS5 $R_{DS(on)}=7.0\text{ m}\Omega$	BSC057N08NS3 G $R_{DS(on)}=5.7\text{ m}\Omega$
											BSZ075N08NS5 $R_{DS(on)}=7.5\text{ m}\Omega$	BSC061N08NS5 $R_{DS(on)}=6.1\text{ m}\Omega$
>10					IPP100N08N3 G $R_{DS(on)}=9.7\text{ m}\Omega$						BSZ084N08NS5 $R_{DS(on)}=8.4\text{ m}\Omega$	BSC072N08NS5 $R_{DS(on)}=7.2\text{ m}\Omega$
	IPD096N08N3 G $R_{DS(on)}=9.6\text{ m}\Omega$							BSB104N08NP3 $R_{DS(on)}=10.4\text{ m}\Omega$	IRL80HS120 $R_{DS(on)}=32.0\text{ m}\Omega$	BSZ110N08NS5 $R_{DS(on)}=11.0\text{ m}\Omega$	BSC117N08NS5 $R_{DS(on)}=11.7\text{ m}\Omega$	
	IPD135N08N3 G $R_{DS(on)}=13.5\text{ m}\Omega$									BSZ123N08NS3 G $R_{DS(on)}=12.3\text{ m}\Omega$	BSC123N08NS3 $R_{DS(on)}=12.3\text{ m}\Omega$	
										BSZ340N08NS3 G $R_{DS(on)}=34.0\text{ m}\Omega$	BSC340N08NS3 G $R_{DS(on)}=34.0\text{ m}\Omega$	

OptiMOS™ and StrongIRFET™ 100 V normal level



$R_{DS(on),max}$ @ $V_{GS}=10\text{ V}$ [mΩ]	TO-252 (DPAK)	TO-263 (D ² PAK)	TO-263 (D ² PAK 7-pin)	TO-262 (I ² PAK)	TO-220	TO-220 FullPAK	TO-247
1-2		IPB020N10N5 $R_{DS(on)}=2.0\text{ m}\Omega$	IPB017N10N5 $R_{DS(on)}=1.7\text{ m}\Omega$				IRF100P218 $R_{DS(on)}=1.1\text{ m}\Omega$
		IPB020N10N5LF $R_{DS(on)}=2.0\text{ m}\Omega$	IPB017N10N5LF $R_{DS(on)}=1.7\text{ m}\Omega$				IRF100P219 $R_{DS(on)}=2.1\text{ m}\Omega$
2-4		IPB027N10N3 G $R_{DS(on)}=2.7\text{ m}\Omega$	IPB024N10N5 $R_{DS(on)}=2.4\text{ m}\Omega$			IPP023N10N5 $R_{DS(on)}=2.3\text{ m}\Omega$	IRFP4468PBF $R_{DS(on)}=2.6\text{ m}\Omega$
		IPB027N10N5 $R_{DS(on)}=2.7\text{ m}\Omega$	IPB025N10N3 G $R_{DS(on)}=2.5\text{ m}\Omega$	IPI030N10N3 G $R_{DS(on)}=3.0\text{ m}\Omega$	IPP030N10N3 G $R_{DS(on)}=3.0\text{ m}\Omega$	IPA030N10N3 G $R_{DS(on)}=3.0\text{ m}\Omega$	
		IPB033N10N5LF $R_{DS(on)}=3.3\text{ m}\Omega$	IPB032N10N5 $R_{DS(on)}=3.2\text{ m}\Omega$		IPP030N10N5 $R_{DS(on)}=3.0\text{ m}\Omega$		
			IPB039N10N3 G $R_{DS(on)}=3.9\text{ m}\Omega$		IPP039N10N5 $R_{DS(on)}=3.9\text{ m}\Omega$		
4-10	IPD050N10N5 $R_{DS(on)}=5.0\text{ m}\Omega$	IPB042N10N3 G $R_{DS(on)}=4.2\text{ m}\Omega$		IPI045N10N3 G $R_{DS(on)}=4.5\text{ m}\Omega$	IRFB4110PBF $R_{DS(on)}=4.5\text{ m}\Omega$	IPA045N10N3 G $R_{DS(on)}=4.5\text{ m}\Omega$	IRFP4110PBF $R_{DS(on)}=4.5\text{ m}\Omega$
	IPD068N10N3 G $R_{DS(on)}=6.8\text{ m}\Omega$	IRFS4010TRL PBF $R_{DS(on)}=4.7\text{ m}\Omega$			IPP045N10N3 G $R_{DS(on)}=4.5\text{ m}\Omega$	IPA083N10N5 $R_{DS(on)}=8.3\text{ m}\Omega$	IRFP4310ZPBF $R_{DS(on)}=6.0\text{ m}\Omega$
		IPB065N10N3 G $R_{DS(on)}=6.5\text{ m}\Omega$			IRFB4310ZPBF $R_{DS(on)}=6.0\text{ m}\Omega$	IPA086N10N3 G $R_{DS(on)}=8.6\text{ m}\Omega$	
		IRFS4310ZTRL PBF $R_{DS(on)}=7.0\text{ m}\Omega$					
				IPI072N10N3 G $R_{DS(on)}=7.2\text{ m}\Omega$	IPP072N10N3 G $R_{DS(on)}=7.2\text{ m}\Omega$		
	IPD082N10N3 G $R_{DS(on)}=8.2\text{ m}\Omega$				IPP083N10N5 $R_{DS(on)}=8.3\text{ m}\Omega$		
		IPB083N10N3 G $R_{DS(on)}=8.3\text{ m}\Omega$		IPI086N10N3 G $R_{DS(on)}=8.6\text{ m}\Omega$	IPP086N10N3 G $R_{DS(on)}=8.6\text{ m}\Omega$		
	IRFS4410ZTRL PBF $R_{DS(on)}=9.0\text{ m}\Omega$			IRFS4410ZTRL PBF $R_{DS(on)}=9.0\text{ m}\Omega$		IRFP4410ZPBF $R_{DS(on)}=9.0\text{ m}\Omega$	
10-25	IPD122N10N3 G $R_{DS(on)}=12.2\text{ m}\Omega$						
	IPD12CN10N G $R_{DS(on)}=12.4\text{ m}\Omega$	IPB123N10N3 G $R_{DS(on)}=12.3\text{ m}\Omega$					
	IRFR4510TRPBF $R_{DS(on)}=13.9\text{ m}\Omega$	IRFS4510TRL PBF $R_{DS(on)}=13.9\text{ m}\Omega$					
	IPD180N10N3 G $R_{DS(on)}=18.0\text{ m}\Omega$			IPI180N10N3 G $R_{DS(on)}=18.0\text{ m}\Omega$			
	IPD25CN10N G $R_{DS(on)}=25.0\text{ m}\Omega$						
>25	IPD33CN10N G $R_{DS(on)}=33.0\text{ m}\Omega$						
	IPD78CN10N G $R_{DS(on)}=78.0\text{ m}\Omega$						



OptiMOS™ and StrongIRFET™ 100 V normal level

$R_{DS(on), max.}$ @ $V_{GS}=10\text{ V}$ [mΩ]	Bare die ($R_{DS(on), typ.}$)	DirectFET™	PQFN 3.3 x 3.3	SuperSO8	SO-8	TO-Leadless	
1-2	IPC302N10N3 $R_{DS(on)}=1.7\text{ m}\Omega$ IPC313N10N3R $R_{DS(on)}=1.9\text{ m}\Omega$					IPT015N10N5 $R_{DS(on)}=1.5\text{ m}\Omega$ IPT020N10N3 $R_{DS(on)}=2.0\text{ m}\Omega$	
2-4	IPC26N10NR $R_{DS(on)}=3.2\text{ m}\Omega$ IPC173N10N3 $R_{DS(on)}=3.6\text{ m}\Omega$	IRF7769L1TRPBF $R_{DS(on)}=3.5\text{ m}\Omega$		BSC027N10NS5 $R_{DS(on)}=2.7\text{ m}\Omega$ BSC035N10NS5 $R_{DS(on)}=3.5\text{ m}\Omega$ BSC040N10NS5 $R_{DS(on)}=4.0\text{ m}\Omega$			
4-10		IRF100DM116 ³⁾ $R_{DS(on)}=4.3\text{ m}\Omega$ BSB056N10NN3 G $R_{DS(on)}=5.6\text{ m}\Omega$		BSC050N10N5 $R_{DS(on)}=5.0\text{ m}\Omega$ BSC060N10NS3 G $R_{DS(on)}=6.0\text{ m}\Omega$ BSC070N10NS3 G $R_{DS(on)}=7.0\text{ m}\Omega$ BSC070N10NS5 $R_{DS(on)}=7.0\text{ m}\Omega$ IRFH5010TRPBF $R_{DS(on)}=9.0\text{ m}\Omega$			
			BSZ097N10NS5 $R_{DS(on)}=9.7\text{ m}\Omega$	BSC098N10NS5 $R_{DS(on)}=9.8\text{ m}\Omega$ BSC109N10NS3 G $R_{DS(on)}=10.9\text{ m}\Omega$ BSC118N10NS G $R_{DS(on)}=11.8\text{ m}\Omega$			
		BSF134N10NJ3 G ¹⁾ $R_{DS(on)}=13.4\text{ m}\Omega$		IRFH7110TRPBF $R_{DS(on)}=13.5\text{ m}\Omega$			
		IPC045N10N3 $R_{DS(on)}=15.2\text{ m}\Omega$		BSZ160N10NS3 G $R_{DS(on)}=16.0\text{ m}\Omega$	BSC160N10NS3 G $R_{DS(on)}=16.0\text{ m}\Omega$ BSC196N10NS G $R_{DS(on)}=19.6\text{ m}\Omega$	IRF7853TRPBF $R_{DS(on)}=18.0\text{ m}\Omega$	
		IRF6662TRPBF $R_{DS(on)}=22.0\text{ m}\Omega$ IRF6645TRPBF $R_{DS(on)}=35.0\text{ m}\Omega$ IRF7665S2TRPBF $R_{DS(on)}=62.0\text{ m}\Omega$		BSZ440N10NS3 G $R_{DS(on)}=44.0\text{ m}\Omega$	BSC252N10NSF G $R_{DS(on)}=25.2\text{ m}\Omega$ BSC440N10NS3 G $R_{DS(on)}=44.0\text{ m}\Omega$ BSC750N10ND G $R_{DS(on)}=75.0\text{ m}\Omega$; dual		
2 x 75							
2 x 195			IRFHM792TRPBF $R_{DS(on)}=195.0\text{ m}\Omega$				

OptiMOS™ and StrongIRFET™ 100 V logic level



$R_{DS(on), max.}$ @ $V_{GS}=10\text{ V}$ [mΩ]	TO-252 (DPAK)	TO-263 (D ² PAK)	TO-263 (D ² PAK 7-pin)	TO-220	Bare die ($R_{DS(on), typ.}$)	PQFN 2 x 2	PQFN 3.3 x 3.3	SuperSO8	SOT-23
2-4			IRLS4030TRL7PP $R_{DS(on)}=3.9\text{ m}\Omega$					BSC034N10LS5 $R_{DS(on)}=3.4\text{ m}\Omega$	
4-10		IRLS4030TRLPBF $R_{DS(on)}=4.3\text{ m}\Omega$		IRLB4030PBF $R_{DS(on)}=4.3\text{ m}\Omega$			BSZ096N10LS5 $R_{DS(on)}=9.6\text{ m}\Omega$		
10-25				IPP12CN10L G $R_{DS(on)}=12.0\text{ m}\Omega$	IPC045N10L3 ²⁾ $R_{DS(on)}=16.0\text{ m}\Omega$		BSZ146N10LS5 $R_{DS(on)}=14.6\text{ m}\Omega$ BSZ150N10LS3 $R_{DS(on)}=15.0\text{ m}\Omega$	BSC123N10LS G $R_{DS(on)}=12.3\text{ m}\Omega$ BSC146N10LS5 $R_{DS(on)}=14.6\text{ m}\Omega$	
	IRLR3110ZTRPBF $R_{DS(on)}=14.0\text{ m}\Omega$							BSC265N10LSF G $R_{DS(on)}=26.5\text{ m}\Omega$	IRLML0100 $R_{DS(on)}=220\text{ m}\Omega$
>25					IPC020N10L3 ²⁾ $R_{DS(on)}=42.0\text{ m}\Omega$	IRL100HS121 $R_{DS(on)}=42.0\text{ m}\Omega$			

www.infineon.com/powermosfet-12V-300V

1) DirectFET™ S
2) $R_{DS(on), typ.}$ specified @ 4.5 V
3) Coming soon



OptiMOS™ and StrongIRFET™ 120 V normal level

$R_{DS(on), max.}$ @ $V_{GS}=10\text{ V}$ [mΩ]	TO-252 (DPAK)	TO-263 (D ² PAK)	TO-263 (D ² PAK 7-pin)	TO-262 (I ² PAK)	TO-220	Bare die ($R_{DS(on) typ.}$)	PQFN 3.3 x 3.3	SuperSO8
2-4						IPC302N12N3 $R_{DS(on)}=2.5\text{ m}\Omega$		
						IPC26N12N $R_{DS(on)}=3.0\text{ m}\Omega$		
		IPB038N12N3 G $R_{DS(on)}=3.8\text{ m}\Omega$	IPB036N12N3 G $R_{DS(on)}=3.6\text{ m}\Omega$			IPC26N12NR $R_{DS(on)}=3.2\text{ m}\Omega$		
4-10				IPI041N12N3 G $R_{DS(on)}=4.1\text{ m}\Omega$	IPP041N12N3 G $R_{DS(on)}=4.1\text{ m}\Omega$			
					IPP048N12N3 G $R_{DS(on)}=4.8\text{ m}\Omega$			
10-25				IPI076N12N3 G $R_{DS(on)}=7.6\text{ m}\Omega$	IPP076N12N3 G $R_{DS(on)}=7.6\text{ m}\Omega$			BSC077N12NS3 G $R_{DS(on)}=7.7\text{ m}\Omega$
	IPD110N12N3 G $R_{DS(on)}=11.0\text{ m}\Omega$	IPB144N12N3 G $R_{DS(on)}=14.4\text{ m}\Omega$		IPI147N12N3 G $R_{DS(on)}=14.7\text{ m}\Omega$	IPP114N12N3 G $R_{DS(on)}=11.4\text{ m}\Omega$ IPP147N12N3 G $R_{DS(on)}=14.7\text{ m}\Omega$		BSZ240N12NS3 G $R_{DS(on)}=24.0\text{ m}\Omega$	BSC190N12NS3 G $R_{DS(on)}=19.0\text{ m}\Omega$

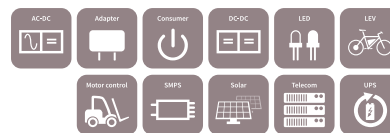

OptiMOST™ and StrongIRFET™ 135-150 V normal level

$R_{DS(on), max.}$ @ $V_{GS}=10\text{ V}$ [mΩ]	Bare die ($R_{DS(on)}$ typ.)	DirectFET™	PQFN 3.3 x 3.3	SuperSO8	TO-Leadless
4-10	IPC302N15N3 $R_{DS(on)}=4.9\text{ m}\Omega$ IPC300N15N3R $R_{DS(on)}=4.9\text{ m}\Omega$			BSC093N15NS5 $R_{DS(on)}=9.3\text{ m}\Omega$	IPT059N15N3 $R_{DS(on)}=5.9\text{ m}\Omega$
10-25		IRF7779L2TRPBF ⁵⁾ $R_{DS(on)}=11.0\text{ m}\Omega$		BSC110N15NS5 $R_{DS(on)}=11.0\text{ m}\Omega$ BSC160N15NS5 $R_{DS(on)}=16.0\text{ m}\Omega$ BSC190N15NS3 G $R_{DS(on)}=19.0\text{ m}\Omega$	
>25		BSB165N15N3 G $R_{DS(on)}=16.5\text{ m}\Omega$ BSB280N15N3 G $R_{DS(on)}=28.0\text{ m}\Omega$ IRF6643TRPBF $R_{DS(on)}=34.5\text{ m}\Omega$ IRF6775MTRPBF $R_{DS(on)}=56.0\text{ m}\Omega$	BSZ300N15NS5 $R_{DS(on)}=30.0\text{ m}\Omega$ BSZ520N15NS3 G $R_{DS(on)}=52.0\text{ m}\Omega$ BSZ900N15NS3 G $R_{DS(on)}=90.0\text{ m}\Omega$	BSC360N15NS3 G $R_{DS(on)}=36.0\text{ m}\Omega$ BSC520N15NS3 G $R_{DS(on)}=52.0\text{ m}\Omega$	



OptiMOST™ and StrongIRFET™ 135-150 V normal level

$R_{DS(on), max.}$ @ $V_{GS}=10\text{ V}$ [mΩ]	TO-252 (DPAK)	TO-263 (D ² PAK)	TO-263 (D ² PAK 7-pin)	TO-263 (D ² PAK 7-pin+)	TO-251/ TO-251 Short Lead (IPAK/IPAK Short Lead)	TO-262 (FPAK)	TO-220	TO-220 FullPAK	TO-247
4-10		IPB048N15N5 $R_{DS(on)}=4.8\text{ m}\Omega$ IPB048N15N5LF $R_{DS(on)}=4.8\text{ m}\Omega$ IPB072N15N3 G $R_{DS(on)}=7.2\text{ m}\Omega$ IPB073N15N5 $R_{DS(on)}=7.3\text{ m}\Omega$ IPB083N15N5LF $R_{DS(on)}=8.3\text{ m}\Omega$ IRF135S203 ⁵⁾ $R_{DS(on)}=8.4\text{ m}\Omega$	IPB044N15N5 $R_{DS(on)}=4.4\text{ m}\Omega$ IRF135SA204 ⁵⁾ $R_{DS(on)}=5.9\text{ m}\Omega$ IPB060N15N5 $R_{DS(on)}=6.0\text{ m}\Omega$ IPB065N15N3 G $R_{DS(on)}=6.5\text{ m}\Omega$	IRF135SA204 $R_{DS(on)}=5.9\text{ m}\Omega$		IPI051N15N5 $R_{DS(on)}=5.1\text{ m}\Omega$ IPI075N15N3 G $R_{DS(on)}=7.5\text{ m}\Omega$ IPI076N15N5 $R_{DS(on)}=7.6\text{ m}\Omega$	IPP051N15N5 ²⁾ $R_{DS(on)}=5.1\text{ m}\Omega$ IPP075N15N3 G $R_{DS(on)}=7.5\text{ m}\Omega$ IPP076N15N5 $R_{DS(on)}=7.6\text{ m}\Omega$	IPA075N15N3 G $R_{DS(on)}=7.5\text{ m}\Omega$	IRF150P220 $R_{DS(on)}=2.5\text{ m}\Omega$ IRF150P221 $R_{DS(on)}=4.8\text{ m}\Omega$ IRFP4568PBF $R_{DS(on)}=5.9\text{ m}\Omega$
10-25		IPB108N15N3 G $R_{DS(on)}=10.8\text{ m}\Omega$ IRFS4321 $R_{DS(on)}=15.0\text{ m}\Omega$ IPD200N15N3 G $R_{DS(on)}=20.0\text{ m}\Omega$ IPB200N15N3 G $R_{DS(on)}=20.0\text{ m}\Omega$	IRFS4115TRL7PP $R_{DS(on)}=11.8\text{ m}\Omega$ IRFS4321TRL7PP $R_{DS(on)}=14.7\text{ m}\Omega$			IPI111N15N3 G $R_{DS(on)}=11.1\text{ m}\Omega$	IPP111N15N3 G $R_{DS(on)}=11.1\text{ m}\Omega$ IRFB4321PBF $R_{DS(on)}=15.0\text{ m}\Omega$ IPP200N15N3 G ²⁾ $R_{DS(on)}=20.0\text{ m}\Omega$	IPA105N15N3 G $R_{DS(on)}=10.5\text{ m}\Omega$	IRFP4321PBF $R_{DS(on)}=15.5\text{ m}\Omega$
>25		IRFS4615PBF $R_{DS(on)}=42.0\text{ m}\Omega$ IRFR4615 $R_{DS(on)}=42.0\text{ m}\Omega$ IPD530N15N3 G $R_{DS(on)}=53.0\text{ m}\Omega$ IPB530N15N3 G $R_{DS(on)}=53.0\text{ m}\Omega$	IRFS5615PBF $R_{DS(on)}=42.0\text{ m}\Omega$		IRFU4615PBF $R_{DS(on)}=42.0\text{ m}\Omega$	IPI530N15N3 G ²⁾ $R_{DS(on)}=53.0\text{ m}\Omega$	IRFB4615PBF $R_{DS(on)}=39.0\text{ m}\Omega$ IRFB5615PBF $R_{DS(on)}=39.0\text{ m}\Omega$ IPP530N15N3 G ²⁾ $R_{DS(on)}=53.0\text{ m}\Omega$ IRFB4019PBF $R_{DS(on)}=95.0\text{ m}\Omega$		

www.infineon.com/powermosfet-12V-300V

2) 8 V rated ($R_{DS(on)}$ also specified @ $V_{GS} = 8\text{ V}$)
3) In development
5) 135 V



OptiMOS™ and StrongIRFET™ 200 V normal level

$R_{DS(on),max}$ @ $V_{GS}=10\text{ V}$ [mΩ]	TO-252 (DPAK)	TO-263 (D ² PAK)	TO-263 (D ² PAK+)	TO-262 (I ² PAK)	TO-220	TO-247
4-10						IRF200P222 $R_{DS(on)}=6.6\text{ m}\Omega$
						IRFP4668PBF $R_{DS(on)}=9.7\text{ m}\Omega$
10-25		IPB107N20N3 G $R_{DS(on)}=10.7\text{ m}\Omega$	IRF200S234 $R_{DS(on)}=16.9\text{ m}\Omega$	IPI110N20N3 G $R_{DS(on)}=11.0\text{ m}\Omega$	IPP110N20N3 G $R_{DS(on)}=11.0\text{ m}\Omega$	IRF200P223 $R_{DS(on)}=11.5\text{ m}\Omega$
		IPB107N20NA ⁴⁾ $R_{DS(on)}=10.7\text{ m}\Omega$				
		IPB110N20N3LF $R_{DS(on)}=11.0\text{ m}\Omega$			IPP120N20NFD $R_{DS(on)}=12.0\text{ m}\Omega$	IRFP4127PBF $R_{DS(on)}=21.0\text{ m}\Omega$
		IPB117N20NFD $R_{DS(on)}=11.7\text{ m}\Omega$			IRFB4127PBF $R_{DS(on)}=20.0\text{ m}\Omega$	IRFP4227PBF $R_{DS(on)}=25.0\text{ m}\Omega$
		IPB156N22NFD ²⁾ $R_{DS(on)}=15.6\text{ m}\Omega$				
>25		IRFS4127TRLPBF $R_{DS(on)}=22.0\text{ m}\Omega$				
		IRFS4227TRLPBF $R_{DS(on)}=26.0\text{ m}\Omega$			IRFB4227PBF $R_{DS(on)}=26.0\text{ m}\Omega$	
	IPD320N20N3 G $R_{DS(on)}=32.0\text{ m}\Omega$	IPB320N20N3 G $R_{DS(on)}=32.0\text{ m}\Omega$		IPI320N20N3 G $R_{DS(on)}=32.0\text{ m}\Omega$	IPP320N20N3 G $R_{DS(on)}=32.0\text{ m}\Omega$	
					IRFB4620PBF $R_{DS(on)}=72.5\text{ m}\Omega$	
	IRFR4620TRLPBF $R_{DS(on)}=78.0\text{ m}\Omega$	IRFS4620TRLPBF $R_{DS(on)}=78.0\text{ m}\Omega$			IRFB5620PBF $R_{DS(on)}=72.5\text{ m}\Omega$	
		IRFS4020TRLPBF $R_{DS(on)}=105.0\text{ m}\Omega$			IRFB4020PBF $R_{DS(on)}=100.0\text{ m}\Omega$	
					IRF200B211 $R_{DS(on)}=170.0\text{ m}\Omega$	

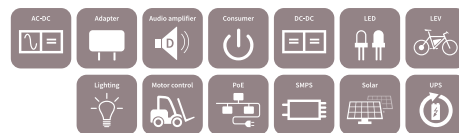

OptiMOS™ and StrongIRFET™ 200 V normal level

$R_{DS(on),max}$ @ $V_{GS}=10\text{ V}$ [mΩ]	Bare die ($R_{DS(on)}$ typ.)	DirectFET™	PQFN 3.3 x 3.3	SuperSO8	SO-8	TO-Leadless	TO-247	
4-10	IPC300N20N3 $R_{DS(on)}=9.2\text{ m}\Omega$						IRF200P222 $R_{DS(on)}=6.6\text{ m}\Omega$	
	IPC302N20N3 $R_{DS(on)}=9.2\text{ m}\Omega$							
10-25	IPC302N20NFD $R_{DS(on)}=9.4\text{ m}\Omega$			BSC220N20NSFD $R_{DS(on)}=22.0\text{ m}\Omega$		IPT111N20NFD $R_{DS(on)}=11.1\text{ m}\Omega$	IRF200P223 $R_{DS(on)}=11.5\text{ m}\Omega$	
>25				BSC320N20NS3 G $R_{DS(on)}=32.0\text{ m}\Omega$				
				BSC350N20NSFD $R_{DS(on)}=35.0\text{ m}\Omega$				
				BSC500N20NS3G $R_{DS(on)}=50.0\text{ m}\Omega$				
		IRF6641TRPBF $R_{DS(on)}=59.9\text{ m}\Omega$			IRFH5020 $R_{DS(on)}=55.0\text{ m}\Omega$			
			BSZ900N20NS3 G $R_{DS(on)}=90.0\text{ m}\Omega$		BSC900N20NS3 G $R_{DS(on)}=90.0\text{ m}\Omega$	IRF7820TRPBF $R_{DS(on)}=78.0\text{ m}\Omega$		
	IRF6785TRPBF $R_{DS(on)}=100.0\text{ m}\Omega$		BSZ12DN20NS3 G $R_{DS(on)}=125.0\text{ m}\Omega$					
			BSZ22DN20NS3 G $R_{DS(on)}=225.0\text{ m}\Omega$					
				BSC12DN20NS3 G $R_{DS(on)}=125.0\text{ m}\Omega$				
				BSC22DN20NS3 G $R_{DS(on)}=225.0\text{ m}\Omega$				

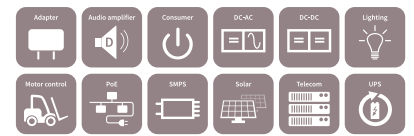

OptiMOS™ and StrongIRFET™ 250 V normal level

$R_{DS(on),max.}$ @ $V_{GS}=10\text{ V}$ [mΩ]	TO-252 (DPAK)	TO-263 (D ² PAK)	TO-262 (I ² PAK)	TO-220	TO-247	Bare die ($R_{DS(on),typ.}$)	PQFN 3.3 x 3.3	SuperSO8	TO-Leadless
10-25		IPB200N25N3 G $R_{DS(on)}=20.0\text{ m}\Omega$	IPI200N25N3 G $R_{DS(on)}=20.0\text{ m}\Omega$	IPP200N25N3 G $R_{DS(on)}=20.0\text{ m}\Omega$	IRF250P224 $R_{DS(on)}=12.0\text{ m}\Omega$				
				IPP220N25NFD $R_{DS(on)}=22.0\text{ m}\Omega$	IRFP4768PBF $R_{DS(on)}=17.5\text{ m}\Omega$	IPC302N25N3 $R_{DS(on)}=16.0\text{ m}\Omega$			IPT210N25NFD $R_{DS(on)}=21.0\text{ m}\Omega$
					IRF250P225 $R_{DS(on)}=22.0\text{ m}\Omega$				
>25								BSC430N25NSFD $R_{DS(on)}=43.0\text{ m}\Omega$	
		IRFS4229TRLPBF $R_{DS(on)}=48.0\text{ m}\Omega$		IRFB4332PBF $R_{DS(on)}=33.0\text{ m}\Omega$	IRFP4332PBF $R_{DS(on)}=33.0\text{ m}\Omega$			BSC600N25NS3 G $R_{DS(on)}=60.0\text{ m}\Omega$	
	IPD600N25N3 G $R_{DS(on)}=60.0\text{ m}\Omega$	IPB600N25N3 G $R_{DS(on)}=60.0\text{ m}\Omega$	IPI600N25N3 G $R_{DS(on)}=60.0\text{ m}\Omega$	IRFB4229PBF $R_{DS(on)}=46.0\text{ m}\Omega$	IRFP4229PBF $R_{DS(on)}=46.0\text{ m}\Omega$		BSZ16DN25NS3 G $R_{DS(on)}=165.0\text{ m}\Omega$	IRFH5025 $R_{DS(on)}=100.0\text{ m}\Omega$	
			IPP600N25N3 G $R_{DS(on)}=60.0\text{ m}\Omega$		IPC045N25N3 $R_{DS(on)}=146.0\text{ m}\Omega$	BSZ42DN25NS3 G $R_{DS(on)}=425.0\text{ m}\Omega$	BSC16DN25NS3 G $R_{DS(on)}=165.0\text{ m}\Omega$		

OptiMOS™ and StrongIRFET™ 300 V normal level



$R_{DS(on),max.}$ @ $V_{GS}=10\text{ V}$ [mΩ]	TO-263 (D ² PAK)	TO-220	TO-247	SuperSO8
0-25			IRF300P226 $R_{DS(on)}=19.0\text{ m}\Omega$	
>25	IPB407N30N $R_{DS(on)}=40.7\text{ m}\Omega$	IPP410N30N $R_{DS(on)}=41.0\text{ m}\Omega$	IRFP4868PBF $R_{DS(on)}=32.0\text{ m}\Omega$	
			IRF300P227 $R_{DS(on)}=40.0\text{ m}\Omega$	
		IRFB4137PBF $R_{DS(on)}=69.0\text{ m}\Omega$	IRFP4137PBF $R_{DS(on)}=69.0\text{ m}\Omega$	BSC13DN30NSFD $R_{DS(on)}=130.0\text{ m}\Omega$

Small signal P-channel



Voltage [V]	SOT-223	TSOP-6	SOT-89	SC59	SOT-23	SOT-323	SOT-363
-250	BSP317P 4 Ω, -0.43 A, LL		BSS192P 12 Ω, -0.19 A, LL	BSR92P 11 Ω, -0.14 A, LL			
	BSP92P 12 Ω, -0.26 A, LL						
	BSP321P 900 mΩ, -0.98 A, NL						
	BSP322P 800 mΩ, -1.0 A, LL						
	BSP316P 1.8 Ω, -0.68 A, LL			BSR316P 1.8 Ω, -0.36 A, LL			
	BSP612P 120 mΩ, 3 A, LL				ISS17EP06LM 1.7Ω, -0.3 A, LL		
	BSP613P 130 mΩ, 2.9 A, NL				BSS83P 2 Ω, -0.33 A, LL	BSS84PW 8 Ω, -0.15 A, LL	
	BSP170P 300 mΩ, -1.9 A, NL				ISS55EP06LM 5.5 Ω, -0.18 A, NL		
	BSP171P 300 mΩ, -1.9 A, LL				BSS84P 8 Ω, -0.17 A, LL		
	BSP315P 800 mΩ, -1.17 A, LL						
	ISP650P06NM 65 mΩ, -3.7 A, NL			BSR315P 800 mΩ, -0.62 A, LL			
	ISP12DP06NM 125 mΩ, -2.8, NL						
-60	ISP25DP06LM 250 mΩ, -1.9 A, LL						
	SP25DP06NM 250 mΩ, -1.9 A, NL						
	SP75DP06LM 750 mΩ, -1.1 A, LL						
		BSL303SPE 33 mΩ, -6.3 A, LL			BSS308PE 80 mΩ, -2.1 A, LL, ESD		BSD314SPE 140 mΩ, -1.5 A, LL, ESD
		IRFTS9342TRPBF* 40 mΩ, -5.8 A, LL			BSS314PE 140 mΩ, -1.5 A, LL, ESD		
		BSL307SP 43 mΩ, -5.5 A, LL			BSS315P 150 mΩ, -1.5 A, LL		
-30		BSL305SPE 45 mΩ, -5.5 A, LL					
		BSL308PE 80 mΩ, -2.1 A, LL, dual, ESD					
		BSL314PE 140 mΩ, -1.5 A, LL, ESD, dual					
-20		BSL207SP 41 mΩ, -6 A, SLL			IRLML2244* 1) 54 mΩ, 4.3 A, LL		
		BSL211SP 67 mΩ, -4.7 A, SLL			IRLML2246* 1) 135 mΩ, 2.6 A, LL	BSS209PW 550 mΩ, -0.58 A, SLL	BSV236SP 175 mΩ, -1.5 A, SLL
					BSS215P 150 mΩ, -1.5 A, SLL	BSS223PW 1.2 Ω, -0.39 A, SLL	BSD223P 1.2 Ω, -0.39 A, SLL, dual

Small signal complementary



Voltage [V]	SOT-223	TSOP-6	SOT-89	SC59	SOT-23	SOT-323	SOT-363
-20/20		BSL215C N: 140 mΩ, 1.5 A, SLL P: 150 mΩ, 1.5 A, SLL					BSD235C N: 350 mΩ, 0.95 A, SLL P: 1.2 Ω, 0.53 A, SLL
-30/30		BSL308C N: 57 mΩ, 2.3 A, LL P: 80 mΩ, -2.0 A, LL					
		BSL316C N: 160 mΩ, 1.4 A, LL P: 150 mΩ, -1.5 A, LL					

www.infineon.com/smallsignal

All products are qualified to Automotive AEC Q101 (except the parts marked with *)

1) R_{DS(on)} 4.5 V rated



Small signal N-channel

Voltage [V]	SOT-223	TSOP-6	SOT-89	SC59	SOT-23	SOT-323	SOT-363
20		BSL802SN 22 mΩ, 7.5 A, ULL		BSR802N 23 mΩ, 3.7 A, ULL	IRLML6244* ¹⁾ 21 mΩ, 6.3 A, LL		
		BSL202SN 22 mΩ, 7.5 A, SLL		BSR202N 21 mΩ, 3.8 A, SLL	IRLML6246* ¹⁾ 46 mΩ, 4.1 A, LL		
		BSL205N 50 mΩ, 2.5 A, SLL, dual			BSS205N 50 mΩ, 2.5 A, SLL		BSD214SN 140 mΩ, 1.5 A, SLL
					BSS806NE 57 mΩ, 2.3 A, ULL, ESD		BSD816SN 160 mΩ, 1.4 A, ULL
		BSL207N 70 mΩ, 2.1 A, SLL, dual			BSS806N 57 mΩ, 2.3 A, ULL	BSS214NW 140 mΩ, 1.5 A, SLL	BSD235N 350 mΩ, 0.95 A, SLL, dual
		BSL214N 140 mΩ, 1.5 A, SLL, dual			BSS214N 140 mΩ, 1.5 A, SLL	BSS816NW 160 mΩ, 1.4 A, ULL	BSD840N 400 mΩ, 0.88 A, ULL, dual
25					IRFML8244* 24 mΩ, 5.8 A, NL		
30		IRLTS6342* ¹⁾ 17.5 mΩ, 8.3 A, LL		BSR302N 23 mΩ, 3.7 A, LL	IRLML0030* 27 mΩ, 5.3 A, LL		BSD316SN 160 mΩ, 1.4A, LL
		IRFTS8342* 19 mΩ, 8.2 A, NL			IRLML6344* ¹⁾ 29 mΩ, 5.0 A, LL		
		BSL302SN 25 mΩ, 7.1 A, LL			BSS306N 57 mΩ, 2.3 A, LL		
		BSL306N 57 mΩ, 2.3 A, LL, dual			IRLML6346* ¹⁾ 63 mΩ, 3.4 A, LL		
					IRLML2030* 100 mΩ, 1.4 A, LL		
55					BSS316N 160 mΩ, 1.4 A, LL		
					BSS670S2L 650 mΩ, 0.54 A, LL	BSS340NW 400 mΩ, 0.88 A, LL	
60	BSP318S 90 mΩ, 2.6 A, LL	BSL606SN 60 mΩ, 4.5 A, LL	BSS606N 60 mΩ, 3.2 A, LL	BSR606N 60 mΩ, 2.3 A, LL	IRLML0060* 92 mΩ, 2.7 A, LL	BSS138W 3.5 Ω, 0.28 A, LL	2N7002DW 3 Ω, 0.3 A, LL, dual
	BSP320S 120 mΩ, 2.9 A, NL				IRLML2060* 480 mΩ, 1.2 A, LL	SN7002W 5 Ω, 0.23 A, LL	
	BSP295 300 mΩ, 1.8 A, LL				BSS138N 3.5 Ω, 0.23 A, LL		
					BSS7728N 5 Ω, 0.2 A, LL		
					SN7002N 5 Ω, 0.2 A, LL		
75	BSP716N 160 mΩ, 2.3 A, LL	BSL716SN 150 mΩ, 2.5 A, LL			2N7002 3 Ω, 0.3 A, LL		
					BSS159N 8 Ω, 0.13 A, depl.		
80							
100	BSP372N 230 mΩ, 1.8 A, LL	BSL372SN 220 mΩ, 2.0 A, LL			IRLML0100* 220 mΩ, 1.6 A, LL		
	BSP373N 240 mΩ, 1.8 A, NL	BSL373SN 230 mΩ, 2.0 A, NL			BSS119N 6 Ω, 0.19 A, LL V _{GS(th)} 1.8 V to 2.3 V		
	BSP296N 600 mΩ, 1.2 A, LL	BSL296SN 460 mΩ, 1.4 A, LL			BSS123N 6 Ω, 0.19 A, LL V _{GS(th)} 0.8 V to 1.8 V		
200	BSP297 1.8 Ω, 0.66 A, LL				BSS169 12 Ω, 0.09 A, depl.		
	BSP149 3.5 Ω, 0.14 A, depl.						
240	BSP88 6 Ω, 0.35 A, 2.8 V rated		BSS87 6 Ω, 0.26 A, LL		BSS131 14 Ω, 0.1 A, LL		
	BSP89 6 Ω, 0.35 A, LL						
	BSP129 6 Ω, 0.05 A, depl.						
250					BSS139 30 Ω, 0.03 A, depl.		
400	BSP298 3 Ω, 0.5 A, NL						
	BSP179 24 Ω, 0.04 A, depl.						
500	BSP324 25 Ω, 0.17 A, LL						
	BSP299 4 Ω, 0.4 A, NL						
600	BSP125 45 Ω, 0.12 A, LL		BSS225 45 Ω, 0.09 A, LL		BSS127 500 Ω, 0.023 A, LL		
	BSP135 60 Ω, 0.02 A, depl.				BSS126 700 Ω, 0.007 A, depl.		
800	BSP300 20 Ω, 0.19 A, NL						

www.infineon.com/smallsignal

All products are qualified to Automotive AEC Q101 (except 2N7002) (except the parts marked with *)

1) R_{DS(on)} specified at 4.5 V

Power P-channel MOSFETs



Voltage [V]	TO-252 (DPAK)	DirectFET™	SOT-23	PQFN 3.3 x 3.3	SuperSO8	SO-8	PQFN 2 x 2	TSOP-6	
-20						BSO201SP H R _{DS(on)} = 7.0 mΩ			
						BSO203SP H R _{DS(on)} = 21.0 mΩ			
						BSO203P H R _{DS(on)} = 21.0 mΩ			
							IRLHS2242TRPBF** R _{DS(on)} = 31.0 mΩ	IRLTS2242 R _{DS(on)} = 39 mΩ	
			IRLML2244 ²⁾ *** R _{DS(on)} = 54 mΩ			BSO207P H R _{DS(on)} = 45.0 mΩ			
			IRLML2246 ²⁾ *** R _{DS(on)} = 135 mΩ			BSO211P H R _{DS(on)} = 67.0 mΩ			
					BSC030P03NS3 G R _{DS(on)} = 3.0 mΩ	IRF9310 R _{DS(on)} = 4.6 mΩ			
	IPD042P03L3 G R _{DS(on)} = 4.2 mΩ				BSC060P03NS3E G R _{DS(on)} = 6.0 mΩ; ESD	IRF9317 R _{DS(on)} = 6.6 mΩ			
				BSZ086P03NS3 G R _{DS(on)} = 8.6 mΩ		IRF9321 R _{DS(on)} = 7.2 mΩ			
	SPD50P03L G ¹⁾ * R _{DS(on)} = 7.0 mΩ	IRF9395M R _{DS(on)} = 7.0 mΩ; dual		BSZ086P03NS3E G R _{DS(on)} = 8.6 mΩ		BSO080P03NS 3 G R _{DS(on)} = 8.0 mΩ			
-30					BSC084P03NS3 G R _{DS(on)} = 8.4 mΩ	BSO080P03NS3E G R _{DS(on)} = 8.0 mΩ; ESD			
					BSC084P03NS3E G R _{DS(on)} = 8.4 mΩ; ESD	BSO080P03S H R _{DS(on)} = 8.0 mΩ			
				BSZ120P03NS3 G R _{DS(on)} = 12.0 mΩ		BSO301SP H R _{DS(on)} = 8.0 mΩ			
				BSZ120P03NS3E G R _{DS(on)} = 12.0 mΩ; ESD		IRF9328 R _{DS(on)} = 11.9 mΩ			
						IRF9388TRPBF R _{DS(on)} = 11.9 mΩ			
						BSO130P03S H R _{DS(on)} = 13.0 mΩ			
						IRF9358 R _{DS(on)} = 16 mΩ; dual			
				IRFHM9331 ²⁾ R _{DS(on)} = 15 mΩ		IRF9332 R _{DS(on)} = 17.5 mΩ			
						IRF9392TRPBF R _{DS(on)} = 17.5 mΩ			
				BSZ180P03NS3 G R _{DS(on)} = 18.0 mΩ		IRF9333 R _{DS(on)} = 19.4 mΩ			
				BSZ180P03NS3E G R _{DS(on)} = 18.0 mΩ; ESD		BSO200P03S H R _{DS(on)} = 20.0 mΩ			
						BSO303SP H R _{DS(on)} = 21.0 mΩ	IRFH9301TRPBF R _{DS(on)} = 37.0 mΩ		
			IRLML9301TRPBF R _{DS(on)} = 64 mΩ			BSO303P H R _{DS(on)} = 21.0 mΩ; dual			
			IRLML9303TRPBF R _{DS(on)} = 165 mΩ			IRF9362 R _{DS(on)} = 21 mΩ; dual	IRFHS9351TRPBF R _{DS(on)} = 170.0 mΩ; dual	IRFTS9342*** R _{DS(on)} = 32 mΩ	
						IRF9335 R _{DS(on)} = 59 mΩ			



Applications
20-300 V MOSFETs
500-950 V MOSFETs
WBG semiconductors
Discrete IGBTs
Power ICS
Gate driver ICS
Motor control ICS
Microcontrollers
XENSIV™ sensors
Packages

Power P-channel MOSFETs



Voltage [V]		TO-252 (DPAK)	TO-263 (D ² PAK)	TO-220	PQFN 3.3 x 3.3	SuperSO8	SO-8
P-channel MOSFETs	-60	IPD380P06NM $R_{DS(on)} = 38 \text{ m}\Omega$	IPB110P06LM $R_{DS(on)} = 11 \text{ m}\Omega$	SPP80P06P H* $R_{DS(on)} = 23.0 \text{ m}\Omega$			
		IPD650P06NM $R_{DS(on)} = 65 \text{ m}\Omega$	SPB80P06P G* $R_{DS(on)} = 23.0 \text{ m}\Omega$				
		SPD30P06P G* $R_{DS(on)} = 75.0 \text{ m}\Omega$					
		IPD900P06NM $R_{DS(on)} = 90 \text{ m}\Omega$					
		SPD18P06P G* $R_{DS(on)} = 130.0 \text{ m}\Omega$	SPB18P06P G* $R_{DS(on)} = 130.0 \text{ m}\Omega$	SPP18P06P H* $R_{DS(on)} = 130.0 \text{ m}\Omega$			BSO613SPV G* $R_{DS(on)} = 130.0 \text{ m}\Omega$
		SPD09P06PL G* $R_{DS(on)} = 250.0 \text{ m}\Omega$					
		IPD25DP06LM $R_{DS(on)} = 250 \text{ m}\Omega$					
		IPD25DP06NM $R_{DS(on)} = 250 \text{ m}\Omega$					
		SPD08P06P G* $R_{DS(on)} = 300.0 \text{ m}\Omega$	SPB08P06P G* $R_{DS(on)} = 300.0 \text{ m}\Omega$	SPP08P06P H* $R_{DS(on)} = 300.0 \text{ m}\Omega$			
		IPD40DP06NM $R_{DS(on)} = 400 \text{ m}\Omega$					
-100	SPD15P10PL G* $R_{DS(on)} = 200.0 \text{ m}\Omega$		SPP15P10PL H* $R_{DS(on)} = 200.0 \text{ m}\Omega$				
	SPD15P10P G* $R_{DS(on)} = 240.0 \text{ m}\Omega$		SPP15P10P H* $R_{DS(on)} = 240.0 \text{ m}\Omega$				
	SPD04P10PL G* $R_{DS(on)} = 850.0 \text{ m}\Omega$						
	SPD04P10P G* $R_{DS(on)} = 1000.0 \text{ m}\Omega$						

Power MOSFETs complementary



Voltage [V]		TO-252 (DPAK)	TO-263 (D ² PAK)	TO-220	PQFN 3.3 x 3.3	SuperSO8	SO-8
Complementary	-20/20	>50 mΩ			BSZ15DC02KD H**/** N: 55 mΩ, 5.1 A P: 150 mΩ, -3.2 A		
	-60/60	11-30 Ω			BSZ215C H**/** N: 55 mΩ, 5.1 A P: 150 mΩ, -3.2 A		BSO612CV G* N: 0.12 Ω, 3.0 A P: 0.30 Ω, -2.0 A BSO615C G* N: 0.11 Ω, 3.1 A P: 0.30 Ω, -2.0 A

www.infineon.com/complementary

*Products are qualified to Automotive AEC Q101

** $R_{DS(on)}$ specified at 4.5 V

Nomenclature

OptiMOS™

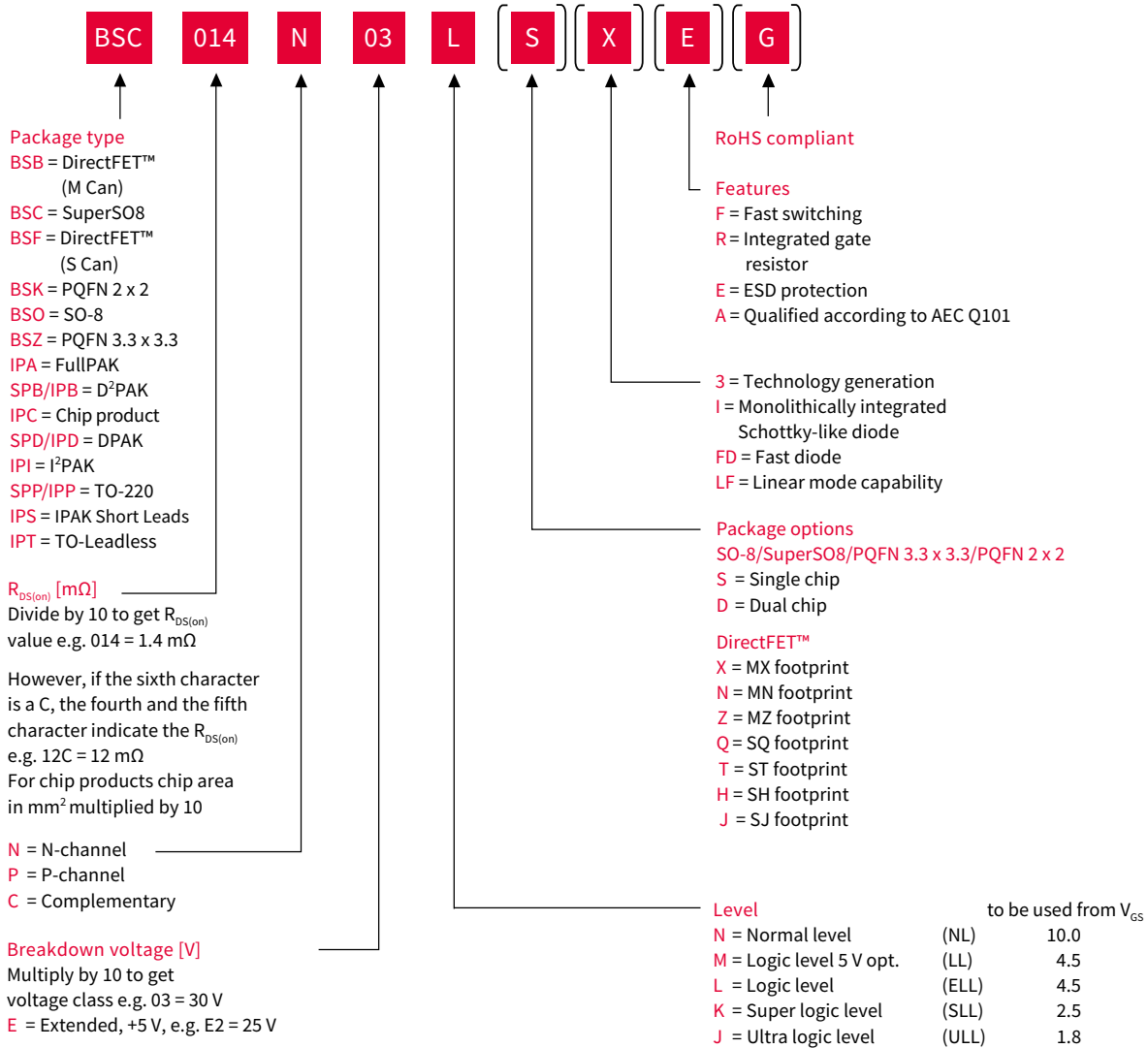

OptiMOS™ 30 V

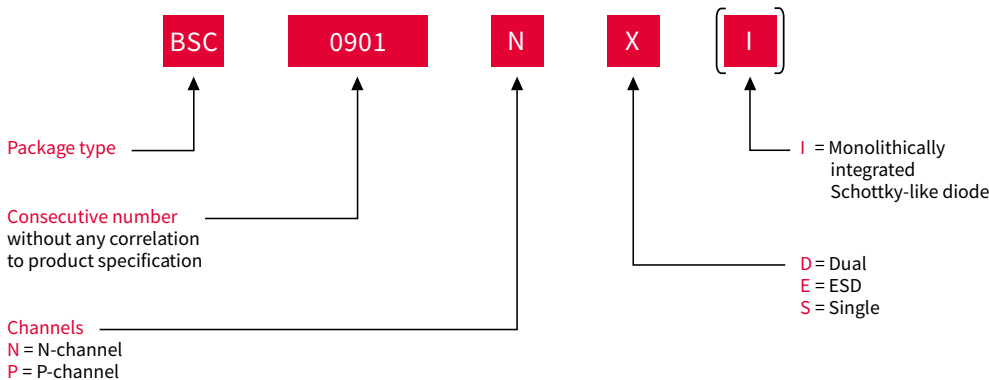

Small signal

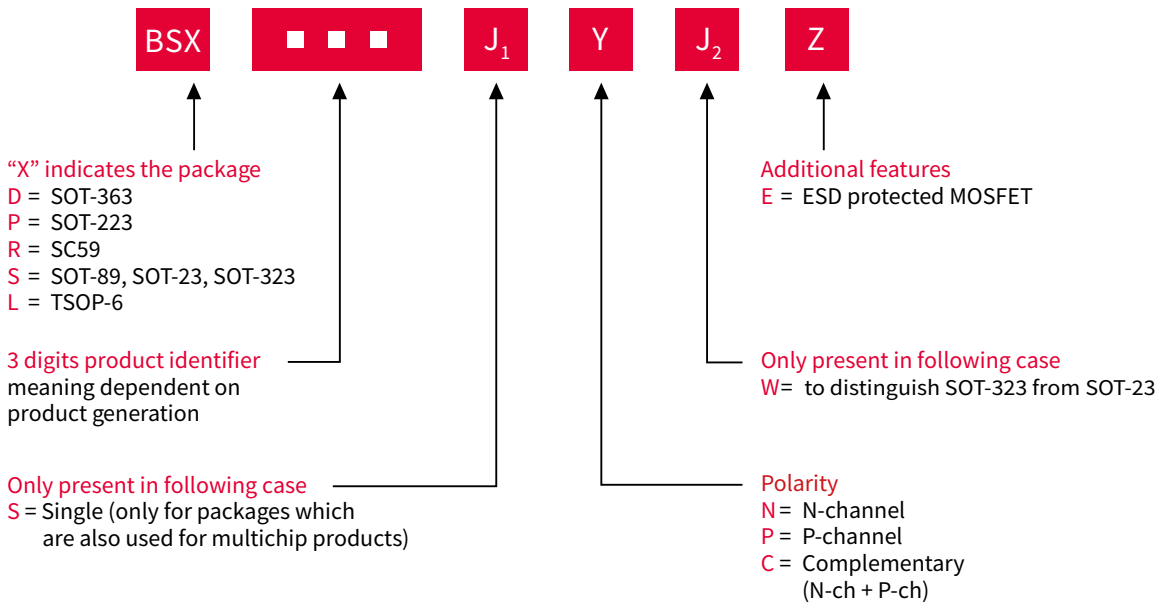

StrongIRFET™ (from May 2015 onwards)

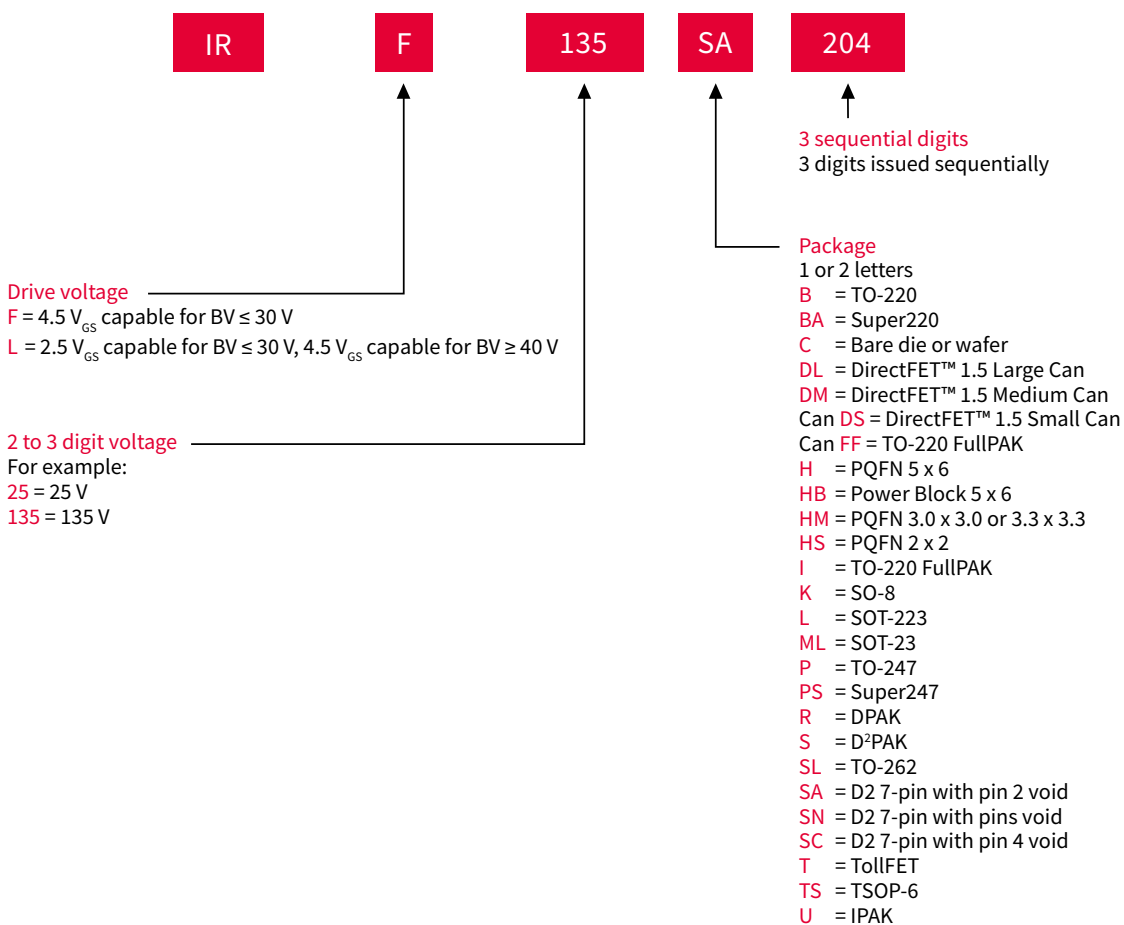



Infineon support for low voltage MOSFETs

Useful links and helpful information

Further information, data sheets and documents

www.infineon.com/powermosfet-12V-300V

www.infineon.com/smallsignal

www.infineon.com/pchannel

www.infineon.com/depletion

www.infineon.com/complementary

www.infineon.com/baredie

Evaluation boards and simulation models

www.infineon.com/to-leadless-evaluationboard

www.infineon.com/powermosfet-simulationmodels

Videos

www.infineon.com/mediacenter



CoolMOS™ SJ MOSFETs

Trusted leader in high voltage MOSFETs

The revolutionary CoolMOS™ power MOSFET family sets new standards in the field of energy efficiency. Our CoolMOS™ products offer a significant reduction of conduction, switching and driving losses, and enable high power density as well as efficiency for superior power conversion systems.

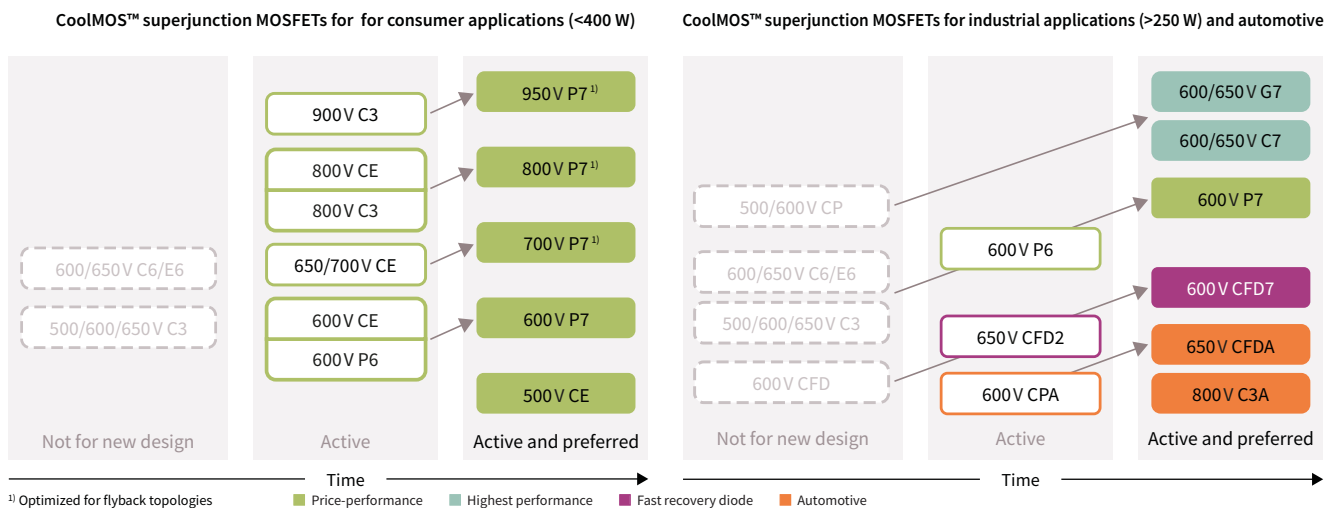

High voltage superjunction MOSFETs address consumer applications, such as smartphone/tablet chargers, notebook adapters, LED lighting, PC power, as well as audio and TV power supplies. Customers are increasingly replacing standard MOSFETs with superjunction MOSFETs to benefit from higher efficiency and lower power consumption for end users. CoolMOS™ P7 sets a new benchmark by offering high performance and competitive price all at once.

Also for industrial applications such as server, telecom, PC power, solar, UPS, EV-charging and others, Infineon's latest CoolMOS™ 7 superjunction MOSFETs with C7, G7, CFD7 and P7 product families offer what you need - from highest efficiency to best price performance. Infineon has meanwhile also complemented the portfolio with first CoolGaN™ e-mode HEMTs products to further optimize efficiency and system cost.

Infineon's CoolMOS™ superjunction MOSFET offering is complemented by the automotive qualified series 600 V CPA, 650 V CFDA and 800 V C3A. Gain your momentum in the rapidly growing on-board charger and DC-DC converter markets with our excellent performing automotive series with proven outstanding quality standards that go well beyond AEC Q101.

950 V CoolMOS™ P7 SJ MOSFET

Perfect fit for PFC and flyback topologies

Designed to meet the growing consumer needs in the high voltage MOSFETs arena, the latest 950 V CoolMOS™ P7 technology focuses on the low-power SMPS market. This new P7 family addresses applications ranging from lighting, smart meter, mobile phone charger, notebook adapter, to AUX power supply and industrial SMPS. Offering 50 V more blocking voltage than its predecessor 900 V CoolMOS™ C3, the new 950 V CoolMOS™ P7 series delivers outstanding performance in terms of efficiency, thermal behavior and ease of use. As the all other P7 family members, the 950 V CoolMOS™ P7 series comes with an integrated Zener diode ESD protection. The integrated diode considerably improves ESD robustness, thus reducing ESD-related yield loss and reaching exceptional ease-of-use levels. CoolMOS™ P7 is developed with best-in-class threshold voltage ($V_{GS(th)}$) of 3 V and a narrow tolerance of only ± 0.5 V, which makes it easy to drive and design-in.

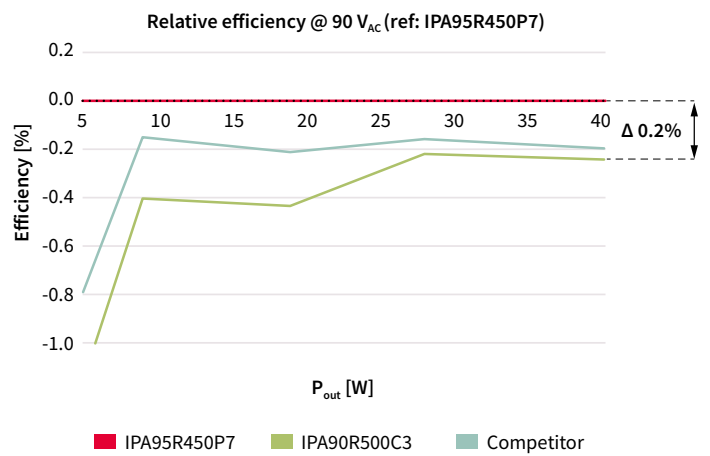
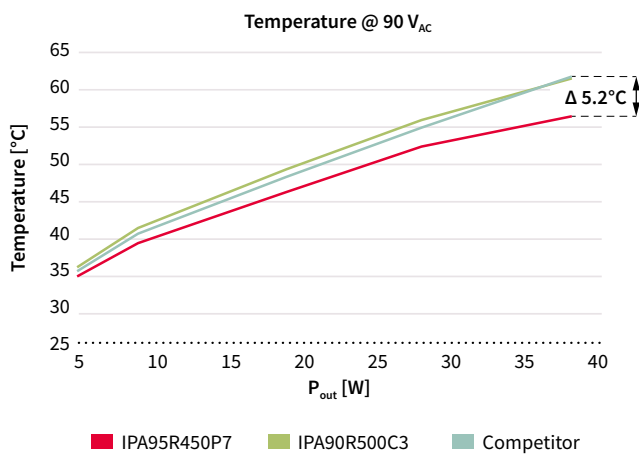

Compared to competition, the 950 V CoolMOS™ P7 delivers best-in-class efficiency and thermal performance. Plug-and-play at 90 V_{AC} in a 40 W adapter reference design, featuring the snubberless concept, demonstrates excellent efficiency gains of up to 0.2 % and lower MOSFET temperature of up to 5.2°C compared to similar competitor technology. With over 20 years of experience in superjunction technology, Infineon introduces 950 V CoolMOS™ P7 with best-in-class DPAK on-resistance ($R_{DS(on)}$). This SMD device comes with the $R_{DS(on)}$ of 450 mΩ - more than 60% lower $R_{DS(on)}$ compared to the nearest competitor. Such low $R_{DS(on)}$ value enables higher density designs while decreasing BOM and assembly cost.

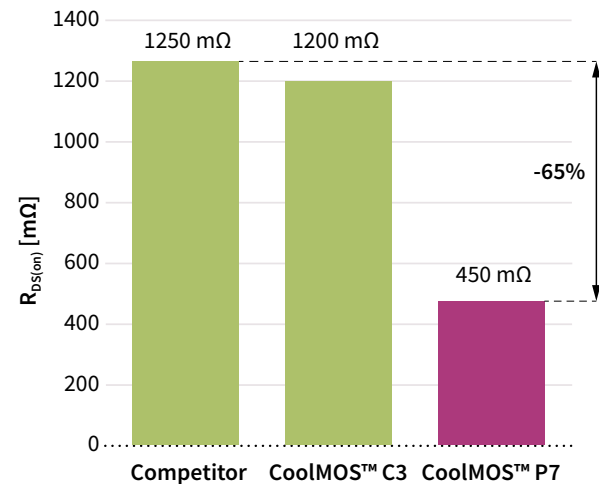

Best-in-class DPAK $R_{DS(on)}$

Customer benefits:

- > Possible change from leaded to SMD packages
- > High power density
- > Lower BOM cost
- > Less production cost



800 V CoolMOS™ P7 SJ MOSFET

A benchmark in efficiency and thermal performance

With the 800 V CoolMOS™ P7 series, Infineon sets a benchmark in 800 V superjunction technologies and combines best-in-class performance with the remarkable ease of use. This new product family is a perfect fit for flyback-based consumer and industrial SMPS applications. In addition, it is also suitable for PFC stages within consumer, as well as solar applications, fully covering the market needs in terms of its price/performance ratio.

The technology offers fully optimized key parameters to deliver best-in-class efficiency as well as thermal performance. As demonstrated on an 80 W LED driver, bought on the market, the >45 percent reduction in switching losses (E_{oss}) and output capacitance (C_{oss}) as well as the significant improvement in input capacitance (C_{iss}) and gate charge (Q_G), compared to competitor technologies, lead to 0.5 percent higher efficiency at light load which helps to reduce standby power in the end application. At full load, the observed improvement is up to 0.3 percent higher efficiency and 6°C lower device temperature.

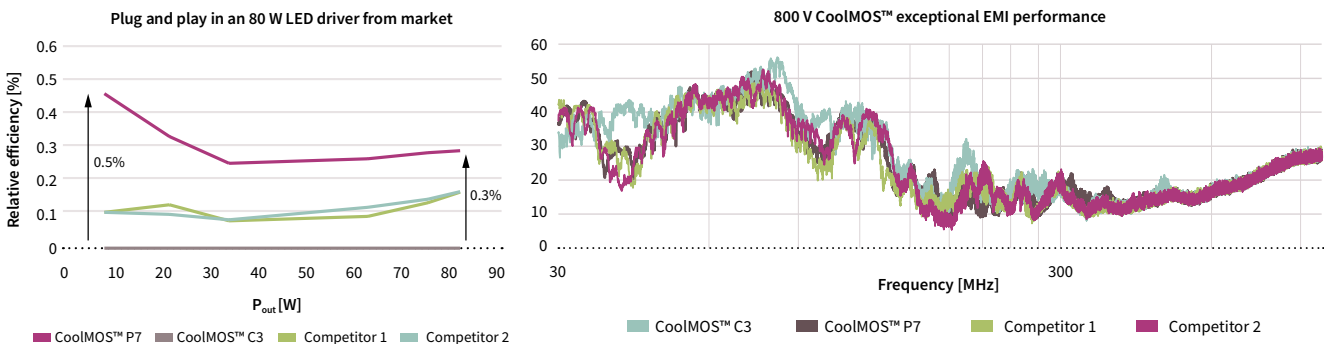

EMI is a system level topic, and the optimization needs to be done on the system level only. Nevertheless, a pure plug-and-play measurement on Infineon's 45 W adapter reveals that 800 V CoolMOS™ P7 shows similar EMI performance to Infineon's previous technologies as well as to competitors' technologies.

Compared to competition, the 800 V CoolMOS™ P7 technology allows to integrate much lower $R_{DS(on)}$ values into small packages, such as a DPAK. This finally enables high power density designs at highly competitive price levels.

Overview of lowest DPAK $R_{DS(on)}$ for 800 V superjunction MOSFET

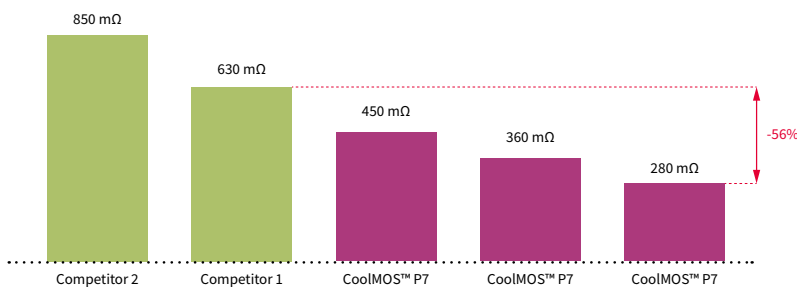

CoolMOS™ P7 sets a new benchmark in best-in-class DPAK $R_{DS(on)}$

Customer benefits:

- > High power density
- > Lower BOM cost
- > Less production cost

The complete P7 platform has been developed with an integrated Zener diode that is used as an electrostatic discharge (ESD) protection mechanism, which increases the overall device ruggedness up to Human body model (HBM) class 2 level.

www.infineon.com/800V-p7



700 V CoolMOS™ P7 SJ MOSFET

Our answer for flyback topologies

The 700 V CoolMOS™ P7 family has been developed to serve today's and, especially, tomorrow's trends in flyback topologies. The family products address the low power SMPS market, mainly focusing on mobile phone chargers and notebook adapters, but are also suitable for power supplies, used within lighting applications, home entertainment (TV, game consoles or audio), and auxiliary power supplies. 700 V CoolMOS™ P7 achieves outstanding efficiency gains of up to 4 percent and a decrease in device temperature of up to 16 K compared to competition. In contrast with the previous 650 V CoolMOS™ C6 technology, 700 V CoolMOS™ P7 offers 2.4 percent gain in efficiency and 12 K lower device temperature, measured at a flyback-based charger application, operated at 140 kHz switching speed.

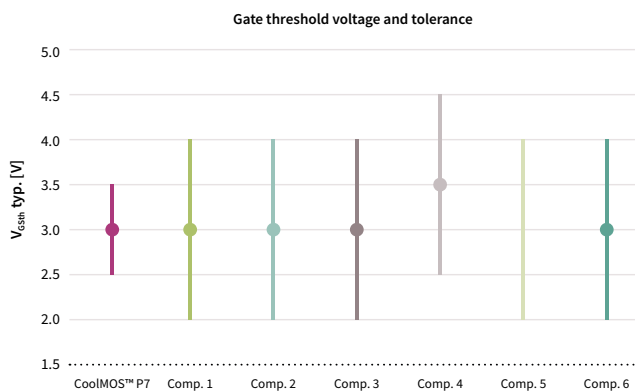
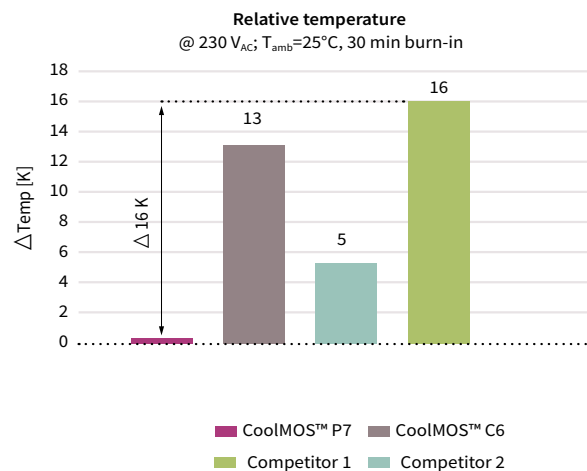
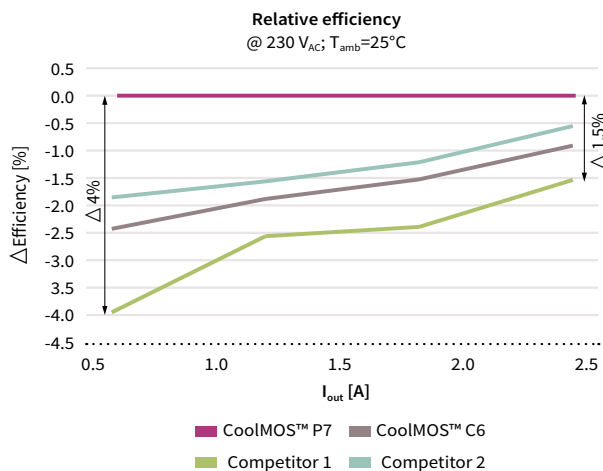

Key features

- › Highly performant technology
 - Low switching losses (E_{oss})
 - Highly efficient
 - Excellent thermal behavior
- › Allowing high speed switching
- › Integrated protection Zener diode
- › Optimized V_{GS(th)} of 3 V with very narrow tolerance of ±0.5 V
- › Finely graduated portfolio

Keeping the ease of use in mind, Infineon has launched the technology with a low threshold voltage (V_{GS(th)}) of 3 V and a very narrow tolerance of ±0.5 V. This makes the CoolMOS™ P7 easy to design-in and enables the usage of lower gate source voltage, which facilitates its driving and leads to lower idle losses. To increase the ESD ruggedness up to HBM class 2 level, 700 V CoolMOS™ P7 has an integrated Zener diode. This helps to support increased assembly yield, leads to reduction of production related failures and, finally, manufacturing cost savings on customer side.

Key benefits

- › Cost competitive technology
- › Further efficiency gain at higher switching speed
- › Supporting less magnetic size with lower BOM costs
- › High ESD ruggedness up to HBM class 2 level
- › Easy to drive and design-in
- › Enabler for smaller form factors and high power density designs
- › Excellent choice in selecting the best fitting product

www.infineon.com/700V-p7



600 V CoolMOS™ P7 SJ MOSFET

Perfect combination between high efficiency and ease of use

The 600 V CoolMOS™ P7 is a general purpose series, targeting a broad variety of applications, ranging from low power SMPS up to the highest power levels. In the low power arena, it is the successor of the 600 V CoolMOS™ CE, and for high power SPMS applications, it is the replacement for the 600 V CoolMOS™ P6, which makes it the perfect choice for applications such as chargers, adapters, lighting, TV power supply, PC power supply, solar, small light electric vehicles, server power supply, telecom power supply, and electric vehicle (EV) charging.

The 600 V CoolMOS™ P7 is Infineon's most well-balanced CoolMOS™ technology in terms of combining the ease of use and excellent efficiency performance. Compared to its predecessors, it offers highest efficiency and improved power density due to the significantly reduced gate charge (Q_G) and switching losses (E_{OSS}) levels, as well as optimized on-state resistance ($R_{DS(on)}$). The carefully selected integrated gate resistors enable very low ringing tendency and, thanks to its outstanding robustness of body diode against hard commutation, it is suitable for hard as well as soft switching topologies, such as LLC. In addition, an excellent ESD capability helps to improve the quality in manufacturing. The 600 V CoolMOS™ P7 family offers a wide range of on-resistance ($R_{DS(on)}$)/package combinations, including THD, as well as SMD devices, at an $R_{DS(on)}$ granularity from 24 to 600 mΩ and comes along with the most competitive price/performance ratio of all 600 V CoolMOS™ offerings.

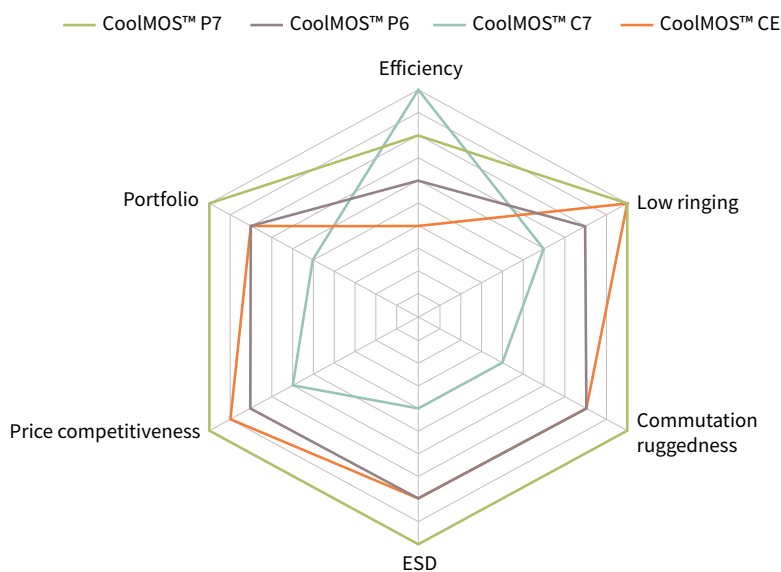

Key features

- › Suitable for hard and soft switching (PFC and LLC) due to an outstanding commutation ruggedness
- › Optimized balance between efficiency and ease of use
- › Significant reduction of switching and conduction losses leading to low MOSFET temperature
- › Excellent ESD robustness >2 kV (HBM) for all products
- › Better $R_{DS(on)}$ /package products compared to competition
- › Large portfolio with granular $R_{DS(on)}$ selection qualified for a variety of industrial and consumer applications

Key benefits

- › Ease of use and fast design-in through low ringing tendency and usage across PFC and PWM stages
- › Improved efficiency and simplified thermal management due to low switching and conduction losses
- › Higher manufacturing quality due to >2 kV ESD protection
- › Increased power density solutions enabled by using products with smaller footprint
- › Suitable for a wide variety of applications and power ranges

www.infineon.com/600V-p7



600 V and 650 V CoolMOS™ C7 and C7 Gold (G7) SJ MOSFET

Infiniteon's highest efficiency superjunction MOSFET series

The 600 V and 650 V CoolMOS™ C7 and C7 Gold (G7) superjunction MOSFET series are designed to achieve record level efficiency performance – they offer substantial efficiency benefits over the whole load range in hard switching applications compared to previous series and competition. This is achieved by minimizing switching losses via ultralow levels of switching losses (E_{oss}) (approximately 50 percent reduction compared to the CoolMOS™ CP), reduced gate charge (Q_G) and a careful balance of other relevant product key parameters. The low E_{oss} and Q_G also enable operation at higher switching frequency and related size reduction of the circuit magnetics.

The outstanding figures of merit (FOM) and the best-in-class on-state resistance ($R_{DS(on)}$) offerings make the CoolMOS™ C7 and C7 Gold series key enablers for highest efficiency and power density. While the 650 V CoolMOS™ C7 and G7 (C7 Gold) superjunction MOSFETs are solely designed for hard switching applications such as PFC, the 600 V version is also well suited for high-end LLC stages due to its rugged body diode that withstands slew rates up to 20 V/ns. The product portfolio contains TO-247 4-pin, ThinPAK 8x8, TO-leadless and top-side cooled Double DPAK (DDPAK) packages which come with additional Kelvin source contacts enabling further efficiency advantages over the classical 3-pin approach.

Key features of CoolMOS™ C7 and C7 Gold (G7)

- > Reduced switching loss parameters such as Q_G and C_{oss} , enabling higher switching frequency
- > 50 percent E_{oss} reduction compared to older CoolMOS™ CP
- > Suitable for hard switching topologies (650 V and 600 V)
- > Suitable for high-end resonant (600 V only) topologies

PFC CCM 1200 W efficiency difference for 90 V_{AC} (PFC CCM, 1.150 W @ 65 kHz)

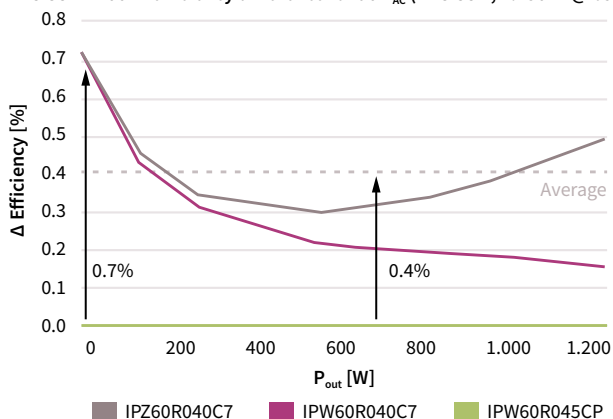

www.infineon.com/c7

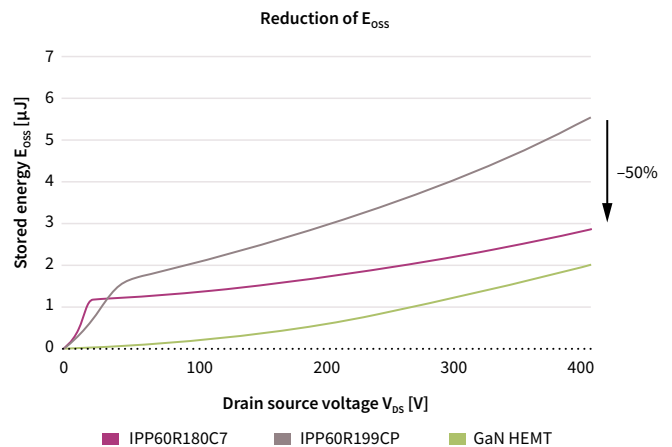

Key benefits of CoolMOS™ C7 and C7 Gold (G7)

- > Increased efficiency in hard switching topologies such as PFC and TTF
- > Reduced size and cost of magnetic components by increased switching frequency (e.g. 65 - 130 kHz)
- > Increased power density by smaller packages for same $R_{DS(on)}$

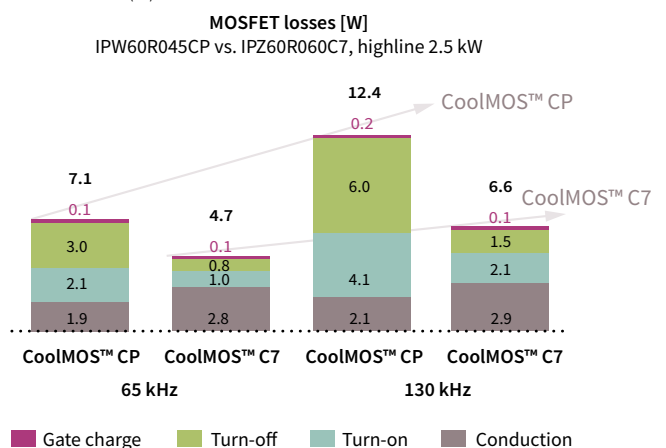

600 V CoolMOS™ CFD7 SJ MOSFET

Infineon's answer to resonant switching high power applications

The 600 V CoolMOS™ CFD7 is Infineon's latest high voltage superjunction MOSFET series with an integrated fast body diode. It is the ideal choice for resonant topologies, such as LLC and ZVS PSFB, and targets the high SMPS market.

As a result of significantly reduced gate charge (Q_G), improved turn-off behavior, a reverse recovery charge (Q_{rr}) of up to 69 percent lower compared to the competition, as well as the lowest reverse recovery time (t_{rr}) in the market, it combines highest efficiency and best-in-class reliability in soft switching applications, without sacrificing the easy implementation in the design-in process.

In addition, the 600 V CoolMOS™ CFD7 enables higher power density solutions by offering best-in-class on-state resistance ($R_{DS(on)}$) package combinations in through-hole devices, as well as in surface-mount devices. In ThinPAK 8x8 and TO-220 with CoolMOS™ CFD7, a $R_{DS(on)}$ of around 30 percent below the next best competitor offering can be achieved. All this together makes CoolMOS™ CFD7 the perfect fit for server and telecom applications, and it is also suitable for EV-charging stations.

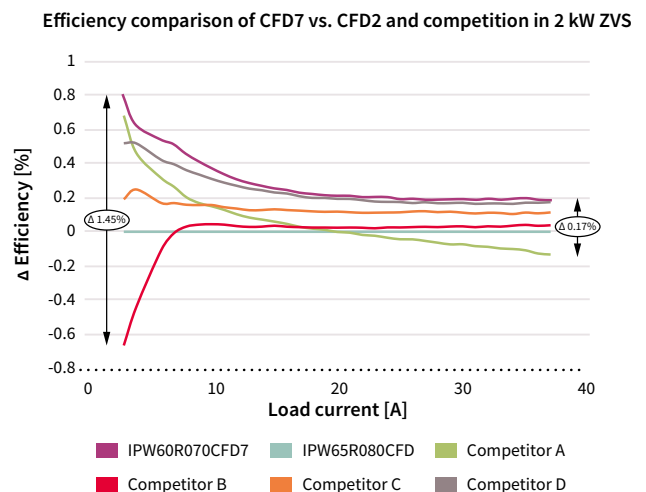
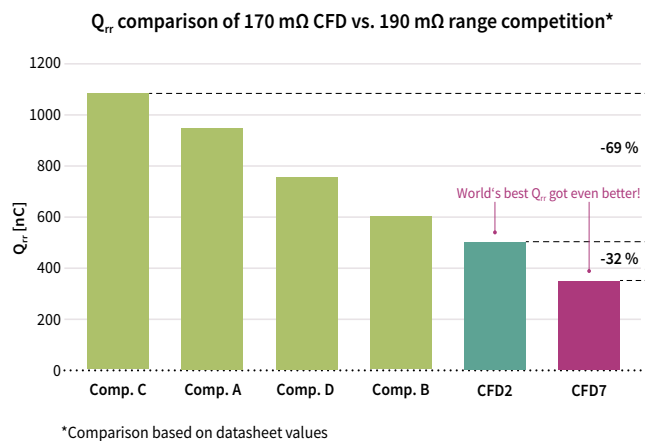

Key features

- › Ultrafast body diode
- › Best-in-class reverse recovery charge (Q_{rr})
- › Improved reverse diode dv/dt and dif/dt ruggedness
- › Lowest figure of merit ($R_{DS(on)} \times Q_G \times E_{oss}$)
- › Best-in-class $R_{DS(on)}$ /package combinations

Key benefits

- › Best-in-class hard commutation ruggedness
- › Highest reliability for resonant topologies
- › Highest efficiency with outstanding ease of use/performance trade-off
- › Enabling increased power density solutions



CoolMOST™ CE SJ MOSFET

High voltage superjunction MOSFETs for consumer

CoolMOST™ CE is a product family launched by Infineon to address consumer and lighting applications. It offers benefits in efficiency and thermal behavior versus standard MOSFETs and is optimized for ease of use and cost-competitiveness, while delivering the right fit performance and excellent Infineon quality.

Application example: 10 W and 15 W smartphone charger

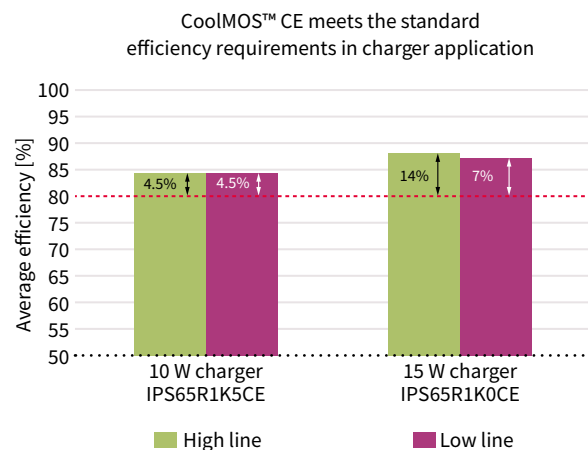
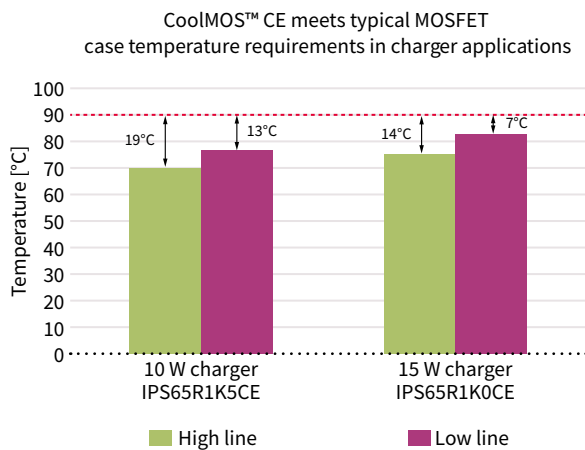

CoolMOST™ CE case temperature:

The maximum MOSFET case temperature is required to be below 90°C. CoolMOST™ CE meets this requirement and offers enough margin required for design-in flexibility.

CoolMOST™ CE efficiency performance:

CoolMOST™ CE meets the 80 percent standard efficiency requirement and offers enough margin required for design-in flexibility.

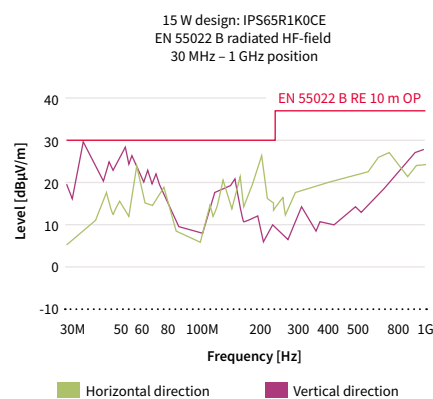
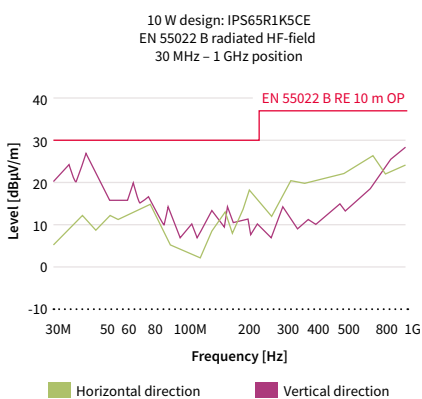

The performance of CoolMOST™ CE in the 10 W and 15 W design demonstrates that the series meets common EMI requirements for charger applications and thus, is also offering design-in flexibility.

CoolMOST™ CE customer benefits	
Product portfolio	We offer a broad portfolio covering five voltage classes in both through-hole and SMD packages
Capacity	We own the world largest capacity for power devices, with three dedicated frontends and four backends
Quality	Our field failure rates are as low as 0.1 DPM
Design-in support	We have a large field application engineering team to provide professional and flexible support for your design

www.infineon.com/ce



CoolMOS™ SJ MOSFET high power package innovations

Space-saving and high performance packages



Innovative top-side cooled SMD solution for high power applications

Top-side cooled Double DPAK (DDPAK)

This is the first top-side cooled surface mount device (SMD) package addressing high power SMPS applications such as PC power, solar, server and telecom. SMD-based SMPS designs support fast switching and help to reduce the parasitic inductance associated with long leaded packages such as the common TO-220 package. In today's SMD-based designs, the output power is restricted by the thermal limit of the PCB material because the heat must be dissipated through the board. Thanks to the top-side cooling concept of DDPAK, the thermal decoupling of board and semiconductor is possible, enabling higher power density or improved system lifetime.



For highest efficiency and controllability in high power SMPS markets

TO-247 4-pin with asymmetric leads

The TO-247 4-pin package with asymmetric leads is an optimized version of the standard TO-247 4-pin and enables highest efficiency and controllability in the high power SMPS market. The fourth pin acts as a Kelvin source. The main current of the switch is placed outside of the gate loop and the feedback is eliminated. This leads to less switching losses, especially at high currents. Secondly, the EMI will be reduced due to cleaner waveforms. In addition, the asymmetric leads further improve the ease of use in the design-in process. Compared to the standard TO-247 4-pin the distance between the critical pins has been increased to enable simplified wave soldering and reduced board yield loss.



Enabling significant space savings

ThinPAK 8x8

With very small footprint of only 64 mm² (vs. 150 mm² for the D²PAK) and a very low profile with only 1 mm height (vs. 4.4 mm for the D²PAK) the ThinPAK 8x8 leadless SMD package for high voltage MOSFETs is a first choice to decrease system size in power-density driven designs. Low parasitic inductance and a separate 4-pin Kelvin source connection offer best efficiency and ease of use. The package is RoHS compliant with halogen-free mold compound.

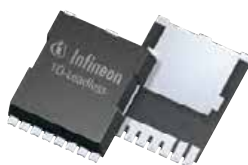

Optimized for high power applications

TO-leadless

Combined with the latest CoolMOS™ C7 Gold (G7) technology, the TO-leadless (TOLL) package is Infineon's flagship SMD package for high power/high current SMD solutions. Compared to D²PAK 7-pin, TO-leadless shows a 30 percent reduction in footprint, yet offers improved thermal performance. This and the 50 percent height reduction result in a significant advantage whenever highest power density is demanded. Equipped with 4-pin Kelvin source connection and low parasitic inductances the package offers best efficiency and ease of use. The package is MSL1 compliant and reflow solderable.

www.infineon.com/coolmos-latest-packages

CoolMOS™ SJ MOSFET low power package innovations

Addressing today's consumer needs



Cost-effective drop-in replacement for DPAK

SOT-223

The SOT-223 package without middle pin is a cost-effective alternative to DPAK, addressing the need for cost reductions in price sensitive applications. It offers a smaller footprint, while still being pin-to-pin compatible with DPAK, thus, allowing a drop-in replacement for DPAK and second sourcing. Moreover, SOT-223 achieves comparable thermal performance to DPAK and enables customers to achieve improved form factors or space savings in designs with low power dissipation.



Solution for slim and small adapters and chargers

ThinPAK 5x6

ThinPAK 5x6 reduces the PCB area by 52 percent and height by 54 percent when compared to the DPAK package which is widely used in chargers and adapters. ThinPAK 5x6 is the right device to replace DPAK and meet the market demands of slimmer and smaller designs. Also ThinPAK 5x6 enables a reduced charger and adapter case hot spot temperature by increasing the space between the MOSFET and the charger and adapter case.



Solution for height reduction in adapters and chargers

TO-220 FullPAK Narrow Lead

Infineon's TO-220 FullPAK Narrow Lead addresses customer needs with regards to height reduction requirements in adapter and charger applications. By offering an optimized standoff width and height and improved creepage distance, the package can be fully inserted into the PCB without any production concerns and, therefore, is especially suitable for slim and semi-slim adapter solutions.



Improved creepage distance for open frame power supplies

TO-220 FullPAK Wide Creepage

This package solution has an increased creepage distance between the pins to 4.25 mm compared to 2.54 mm of a TO-220 FullPAK package. It targets open frame power supplies such as TV sets and PC power, where dust can enter the case through air vents. Dust particles can reduce the effective creepage between pins over time, which may lead to high voltage arcing. The package meets the requirements of open frame power supplies without any additional measures. Thus, it reduces system cost by offering an alternative to frequently used approaches to increase creepage distance.

www.infineon.com/coolmos-latest-packages

CoolMOST™ SJ MOSFET for automotive

600 V CoolMOST™ CPA and 650 V CoolMOST™ CFDA –
on the fast lane in automotive applications

Highest system performance in a size and weight constrained environment, outstanding and proven product quality and reliability, as well as 100 percent reliable delivery are the needs of our automotive customers. With the high voltage automotive MOSFET series 600 V CoolMOST™ CPA and 650 V CoolMOST™ CFDA, Infineon is perfectly prepared to take the challenges in the strongly growing automotive market.

Product series	Key features	Applications	Quality
600 V CoolMOST™ CPA	Best choice for demanding hard switching applications <ul style="list-style-type: none"> › Lowest $R_{DS(on)}$ per package › Lowest gate charge value Q_g 	<ul style="list-style-type: none"> › Hard switching topologies › PFC boost stages in on-board charger › Active clamp or two transistor forward in DC-DC converter 	Quality level well beyond the formal requirements of the AEC Q101 standard through <ul style="list-style-type: none"> › Special screening measures in front end, back end › Mission-profile based qualification procedures
650 V CoolMOST™ CFDA	Easy implementation of layout and design <ul style="list-style-type: none"> › Integrated fast body diode › Limited voltage overshoot during hard commutation – self-limiting dI/dt and dV/dt › Low Q_{rr} at repetitive commutation on body diode and low Q_{oss} 	<ul style="list-style-type: none"> › Resonant switching topologies › DC-DC stage of OBC › LLC or full-bridge ZVS in DC-DC converter › HID lamp 	

CoolMOST™ SJ MOSFET automotive – benchmark in quality and reliability

Focus on top-notch quality and reliability without any compromise – that is the principle Infineon applies during development and qualification of all CoolMOST™ superjunction technologies. For our automotive grade derivatives, the great quality levels of the industrial base technologies are further boosted by special screening measures in front and back end, as well as by extended qualification procedures. The Infineon robustness validation approach with extended stress-test procedures, doubling the real application requirements, is one of our key measures to ensure a quality level well beyond the formal requirements of the AEC Q101 standard. Aside from extended stress times on standard qualification tests, it comprises test procedures, specially developed by Infineon to ensure highest quality of e.g., the power metallization of our devices. Usage of robust package technologies, 100 percent gate oxide screening, and top-notch production monitoring, including yield screening measures, part average testing (PAT), statistical bin alarm (SBA), and pattern recognition procedures, complete our package to guarantee highest automotive quality. This holistic approach results in an unrivalled quality position of our 600 V CoolMOST™ CPA and 650 V CoolMOST™ CFDA.

Robustness validation – example for thermal cycling test

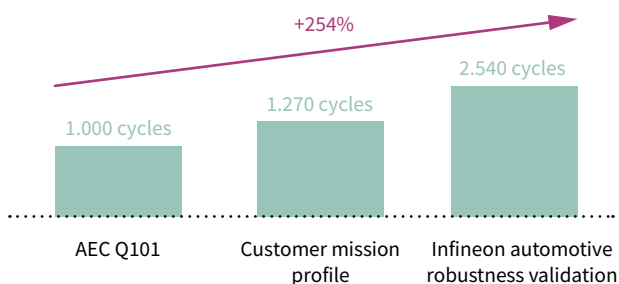

www.infineon.com/cfda

www.infineon.com/coolmos-automotive





CoolMOS™ SJ MOSFET automotive – ready to support future application trends

Driven by the carbon dioxide (CO₂) reduction initiatives, the market of plug-in hybrid PHEV and pure EV is strongly growing. Higher ranges of the electric vehicles are realized by increasing the battery capacity and the energy efficiency of the used electric components. The used battery voltage classes tend to become standardized at 270 V, 480 V and 870 V with a trend towards the higher voltages, as this supports faster charging times and enables lighter cabling within the vehicle. Discrete high voltage components are widely used for on board charger (OBC) and DC-DC converter (LDC) applications, as price pressure increasingly displaces module-based solutions. The trend towards fast charging impacts on the power range demanded from OBC topologies. Presently, as well as in the past, a vast majority of OBC topologies have been found in the range from 3.2 kW to 7.2 kW, whereas the future tends to stir the trend towards 11 kW or even up to 22 kW. This development, paired with a demand for high efficiency and power density at low system cost, is a strong driver for the usage of three-phase solutions.

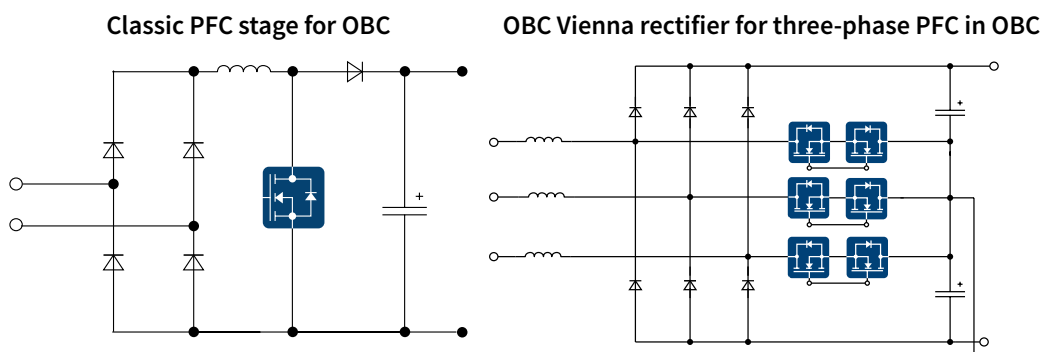

While for the lower power OBC solutions classic PFC approaches are the well-established approaches in the market, the Vienna rectifier is the optimal solution for the higher power levels. As a true three-phase topology, it delivers full power if attached to a three-phase input but is flexible enough to run on a single-phase if required. The three-level topology minimizes the filter effort compared to other solutions. By using the doubled frequency on the magnetic components, it also helps to significantly reduce the size of the passives. As a three-level topology, the Vienna rectifier, followed by two paralleled DC-DC stages, furthermore leads to a relaxed voltage stress level on the power MOSFETs. This way, it enables to handle upcoming higher battery voltage levels. The $R_{DS(on)}$, required to yield a desired efficiency level in a Vienna Rectifier, is a function of applied switching frequency and demanded power level. With our 600 V CoolMOS™ CPA and 650 V CoolMOS™ CFDA portfolio, covering an $R_{DS(on)}$ range from 45 to 660 mΩ, we are well prepared to support your next generation three-phase Vienna rectifier design. With CoolMOS™ you are ready to seize your share in the emerging high-power onboard-charger markets.

www.infineon.com/coolmos-automotive

950 V CoolMOST™ P7 **ACTIVE & PREFERRED**

$R_{DS(on)}$ [mΩ]	TO-220	TO-220 FullPAK	SOT-223	TO-251 Long lead	TO-252 (DPAK)	TO-220 Wide creepage	ThinPAK 8x8	D ² PAK
450		IPA95R450P7		IPU95R450P7	IPD95R450P7			
750		IPA95R750P7		IPU95R750P7	IPD95R750P7			
1200		IPA95R1K2P7	IPN95R1K2P7	IPU95R1K2P7	IPD95R1K2P7			
2000			IPN95R2K0P7	IPU95R2K0P7	IPD95R2K0P7			
3700			IPN95R3K7P7	IPU95R3K7P7				

900 V CoolMOST™ C3 **ACTIVE**

$R_{DS(on)}$ [mΩ]	TO-220	TO-262 (I ² PAK)	TO-263 (D ² PAK)	TO-220 FullPAK	TO-247	TO-252 (DPAK)
120					IPW90R120C3	
340	IPP90R340C3	IPi90R340C3	IPB90R340C3	IPA90R340C3	IPW90R340C3	
500		IPi90R500C3		IPA90R500C3	IPW90R500C3	
800	IPP90R800C3			IPA90R800C3		
1000	IPP90R1K0C3			IPA90R1K0C3		
1200	IPP90R1K2C3	IPi90R1K2C3		IPA90R1K2C3		IPD90R1K2C3

800 V CoolMOST™ P7 **ACTIVE & PREFERRED**

$R_{DS(on)}$ [mΩ]	TO-220	TO-220 FullPAK	TO-247	TO-252 (DPAK)	TO-251 (IPAK)	TO-251 (IPAK Short Lead)	SOT-223	TO-220 FullPAK narrow lead	ThinPAK 5x6*
280	IPP80R280P7	IPA80R280P7	IPW80R280P7	IPD80R280P7				IPAN80R280P7	
360	IPP80R360P7	IPA80R360P7	IPW80R360P7	IPD80R360P7				IPAN80R360P7	
450	IPP80R450P7	IPA80R450P7		IPD80R450P7				IPAN80R450P7	
600	IPP80R600P7	IPA80R600P7		IPD80R600P7	IPU80R600P7	IPS80R600P7	IPN80R600P7		IPLK80R600P7*
750	IPP80R750P7	IPA80R750P7		IPD80R750P7	IPU80R750P7	IPS80R750P7	IPN80R750P7		IPLK80R750P7*
900	IPP80R900P7	IPA80R900P7		IPD80R900P7	IPU80R900P7	IPS80R900P7	IPN80R900P7		IPLK80R900P7*
1200	IPP80R1K2P7	IPA80R1K2P7		IPD80R1K2P7	IPU80R1K2P7	IPS80R1K2P7	IPN80R1K2P7		IPLK80R1K2P7*
1400	IPP80R1K4P7	IPA80R1K4P7		IPD80R1K4P7	IPU80R1K4P7	IPS80R1K4P7	IPN80R1K4P7		IPLK80R1K4P7*
2000				IPD80R2K0P7	IPU80R2K0P7	IPS80R2K0P7	IPN80R2K0P7		IPLK80R2K0P7*
2400				IPD80R2K4P7	IPU80R2K4P7	IPS80R2K4P7	IPN80R2K4P7		
3300				IPD80R3K3P7	IPU80R3K3P7		IPN80R3K3P7		
4500				IPD80R4K5P7	IPU80R4K5P7		IPN80R4K5P7		

www.infineon.com/coolmos
www.infineon.com/c3

* Coming soon

www.infineon.com/800v-p7
www.infineon.com/950v-p7

800 V CoolMOST™ CE **ACTIVE**

$R_{DS(on)}$ [mΩ]	TO-220	TO-220 FullPAK	TO-247	TO-252 (DPAK)	TO-251 (IPAK)	TO-251 (IPAK Short Lead)
310		IPA80R310CE				
460		IPA80R460CE				
650		IPA80R650CE				
1000		IPA80R1K0CE		IPD80R1K0CE	IPU80R1K0CE	
1400		IPA80R1K4CE		IPD80R1K4CE		
2800				IPD80R2K8CE		

800 V CoolMOST™ C3 **ACTIVE**

$R_{DS(on)}$ [mΩ]	TO-220	TO-262 (I ² PAK)	TO-263 (D ² PAK)	TO-220 FullPAK	TO-247	TO-252 (DPAK)
85					SPW55N80C3	
290	SPP17N80C3		SPB17N80C3	SPA17N80C3	SPW17N80C3	
450	SPP11N80C3			SPA11N80C3	SPW11N80C3	
650	SPP08N80C3			SPA08N80C3		
900	SPP06N80C3			SPA06N80C3		SPD06N80C3
1300	SPP04N80C3			SPA04N80C3		SPD04N80C3
2700				SPA02N80C3		SPD02N80C3

700 V CoolMOST™ P7 **ACTIVE & PREFERRED**

$R_{DS(on)}$ [mΩ]	TO-220	TO-262 (I ² PAK)	TO-251 (IPAK Short Lead)	TO-220 FullPAK	ThinPAK 5x6	TO-252 (DPAK)	TO-220 FullPAK narrow lead	TO-251 (IPAK Short Lead w/ ISO Standoff)	SOT-223
360			IPS70R360P7S	IPA70R360P7S		IPD70R360P7S	IPAN70R360P7S	IPSA70R360P7S	IPN70R360P7S
450				IPA70R450P7S			IPAN70R450P7S	IPSA70R450P7S	IPN70R450P7S
600			IPS70R600P7S	IPA70R600P7S	IPLK70R600P7	IPD70R600P7S	IPAN70R600P7S	IPSA70R600P7S	IPN70R600P7S
750				IPA70R750P7S	IPLK70R750P7		IPAN70R750P7S	IPSA70R750P7S	IPN70R750P7S
900			IPS70R900P7S	IPA70R900P7S	IPLK70R900P7	IPD70R900P7S	IPAN70R900P7S	IPSA70R900P7S	IPN70R900P7S
1200					IPLK70R1K2P7			IPSA70R1K2P7S	IPN70R1K2P7S
1400			IPS70R1K4P7S		IPLK70R1K4P7	IPD70R1K4P7S		IPSA70R1K4P7S	IPN70R1K4P7S
2000					IPLK70R2K0P7			IPSA70R2K0P7S	IPN70R2K0P7S

700 V CoolMOST™ CE **ACTIVE**

$R_{DS(on)}$ [mΩ]	TO-220	TO-220 FullPAK Wide Creepage	TO-262 (I ² PAK)	TO-251 (IPAK Short Lead with ISO Standoff)	TO-252 (DPAK)	TO-251 (IPAK)	TO-251 (IPAK Short Lead)	SOT-223
600		IPAW70R600CE		IPSA70R600CE	IPD70R600CE			
950		IPAW70R950CE	IPi70R950CE	IPSA70R950CE	IPD70R950CE		IPS70R950CE	
1000								IPN70R1K0CE
1400				IPSA70R1K4CE	IPD70R1K4CE		IPS70R1K4CE	
1500								IPN70R1K5CE
2000				IPSA70R2K0CE	IPD70R2K0CE		IPS70R2K0CE	
2100								IPN70R2K1CE

www.infineon.com/coolmos
www.infineon.com/c3

www.infineon.com/ce
www.infineon.com/700v-p7

* Coming soon

650 V CoolMOST™ C7 Gold (G-series) **ACTIVE & PREFERRED**

$R_{DS(on)}$ [mΩ]	TO-220	TO-Leadless (TOLL)	TO-263 (D ² PAK)	TO-220 FullPAK	TO-247	TO-252 (DPAK)
33		IPT65R033G7				
105		IPT65R105G7				
195		IPT65R195G7				

650 V CoolMOST™ C7 **ACTIVE & PREFERRED**

$R_{DS(on)}$ [mΩ]	TO-220	TO-263 (D ² PAK)	TO-220 FullPAK	TO-247	TO-247 4-pin	TO-252 (DPAK)	ThinPAK 8x8
19				IPW65R019C7	IPZ65R019C7		
45	IPP65R045C7	IPB65R045C7	IPA65R045C7	IPW65R045C7	IPZ65R045C7		
65	IPP65R065C7	IPB65R065C7	IPA65R065C7	IPW65R065C7	IPZ65R065C7		
70							IPL65R070C7
95	IPP65R095C7	IPB65R095C7	IPA65R095C7	IPW65R095C7	IPZ65R095C7		
99							IPL65R099C7
125	IPP65R125C7	IPB65R125C7	IPA65R125C7	IPW65R125C7			
130							IPL65R130C7
190	IPP65R190C7	IPB65R190C7	IPA65R190C7	IPW65R190C7		IPD65R190C7	
195							IPL65R195C7
225	IPP65R225C7	IPB65R225C7	IPA65R225C7			IPD65R225C7	
230							IPL65R230C7

650 V CoolMOST™ CE **ACTIVE**

$R_{DS(on)}$ [mΩ]	TO-220	TO-220 FullPAK	TO-247	TO-252 (DPAK)	TO-251 (IPAK)	TO-251 (IPAK Short Lead)	SOT-223	TO-220 FullPAK Narrow Lead
400		IPA65R400CE		IPD65R400CE		IPS65R400CE		
650		IPA65R650CE		IPD65R650CE		IPS65R650CE		IPAN65R650CE
1000		IPA65R1K0CE		IPD65R1K0CE		IPS65R1K0CE		
1500		IPA65R1K5CE		IPD65R1K5CE			IPN65R1K5CE	

650 V CoolMOST™ CFD2 **ACTIVE**

$R_{DS(on)}$ [mΩ]	TO-220	TO-262 (I ² PAK)	TO-263 (D ² PAK)	TO-220 FullPAK	TO-247	TO-252 (DPAK)	ThinPAK 8x8
41					IPW65R041CFD		
80					IPW65R080CFD		
110	IPP65R110CFD		IPB65R110CFD	IPA65R110CFD	IPW65R110CFD		
150	IPP65R150CFD		IPB65R150CFD	IPA65R150CFD	IPW65R150CFD		
165							IPL65R165CFD
190	IPP65R190CFD	IPI65R190CFD	IPB65R190CFD	IPA65R190CFD	IPW65R190CFD		
210							IPL65R210CFD
310	IPP65R310CFD		IPB65R310CFD	IPA65R310CFD			
340							IPL65R340CFD
420	IPP65R420CFD			IPA65R420CFD	IPW65R420CFD	IPD65R420CFD	
660				IPA65R660CFD		IPD65R660CFD	
950						IPD65R950CFD	
1400						IPD65R1K4CFD	

www.infineon.com/coolmos

www.infineon.com/g7

www.infineon.com/c7

www.infineon.com/cfd2

www.infineon.com/ce

600 V CoolMOST™ P7 **ACTIVE & PREFERRED**

Industrial grade

$R_{DS(on)}$ [mΩ]	TO -220	TO-220 FullPAK	TO-247	TO-247 4-pin asymmetric leads	TO-252 (DPAK)	TO-220 FullPAK Wide Creepage	ThinPAK 8x8	D ² PAK
24			IPW60R024P7	IPZA60R024P7				
37			IPW60R037P7	IPZA60R037P7				
45			IPW60R045P7	IPZA60R045P7				IPB60R045P7
60	IPP60R060P7	IPA60R060P7	IPW60R060P7	IPZA60R060P7				IPB60R060P7
65							IPL60R065P7	
80	IPP60R080P7	IPA60R080P7	IPW60R080P7	IPZA60R080P7			IPL60R085P7	IPB60R080P7
99	IPP60R099P7	IPA60R099P7	IPW60R099P7	IPZA60R099P7				IPB60R099P7
105							IPL60R105P7	
120	IPP60R120P7	IPA60R120P7	IPW60R120P7	IPZA60R120P7				IPB60R120P7
125							IPL60R125P7	
160	IPP60R160P7	IPA60R160P7						
180	IPP60R180P7	IPA60R180P7	IPW60R180P7	IPZA60R180P7	IPD60R180P7			IPB60R180P7
185							IPL60R185P7	
280	IPP60R280P7	IPA60R280P7			IPD60R280P7			IPB60R280P7
285							IPL60R285P7	
360	IPP60R360P7	IPA60R360P7			IPD60R360P7			IPB60R360P7
365							IPL60R365P7	
600	IPP60R600P7	IPA60R600P7			IPD60R600P7			

600 V CoolMOST™ P7 **ACTIVE & PREFERRED**

Standard grade



$R_{DS(on)}$ [mΩ]	TO -220	TO-220 FullPAK	TO-220 FullPAK Narrow lead	TO-247 4-pin	TO-252 (DPAK)	TO-220 FullPAK Wide Creepage	ThinPAK 8x8	SOT-223
180		IPA60R180P7S	IPAN60R180P7S		IPD60R180P7S	IPAW60R180P7S		
280		IPA60R280P7S	IPAN60R280P7S		IPD60R280P7S	IPAW60R280P7S		
360		IPA60R360P7S	IPAN60R360P7S		IPD60R360P7S	IPAW60R360P7S		IPN60R360P7S
600		IPA60R600P7S	IPAN60R600P7S		IPD60R600P7S	IPAW60R600P7S		IPN60R600P7S

600 V CoolMOST™ CFD7 **ACTIVE & PREFERRED**

$R_{DS(on)}$ [mΩ]	TO-220	TO-263 (D ² PAK)	TO-220 FullPAK	TO-247	TO-247 4-pin	TO-252 (DPAK)	ThinPAK 8x8
18				IPW60R018CFD7			
24				IPW60R024CFD7*			
31				IPW60R31CFD7			
40		IPB60R040CFD7*		IPW60R40CFD7			
55		IPB60R055CFD7*		IPW60R55CFD7			
60							IPL60R060CFD7
70	IPP60R70CFD7	IPB60R070CFD7*		IPW60R70CFD7			
75							IPL60R75CFD7
90/95	IPP60R90CFD7	IPB60R090CFD7*		IPW60R90CFD7			IPL60R095CFD7
105/115	IPP60R105CFD7	IPB60R105CFD7*		IPW60R105CFD7			IPL60R115CFD7
125/140	IPP60R125CFD7	IPB60R125CFD7*	IPA60R125CFD7	IPW60R125CFD7			IPL60R140CFD7
145/160	IPP60R145CFD7	IPB60R145CFD7*	IPA60R145CFD7	IPW60R145CFD7		IPD60R145CFD7	IPL60R160CFD7
170	IPP60R170CFD7	IPB60R170CFD7*	IPA60R170CFD7	IPW60R170CFD7		IPD60R170CFD7	
185							IPL60R185CFD7
210/225	IPP60R210CFD7	IPB60R210CFD7*	IPA60R210CFD7			IPD60R210CFD7	IPL60R225CFD7*
280	IPP60R280CFD7	IPB60R280CFD7*	IPA60R280CFD7			IPD60R280CFD7	
360	IPP60R360CFD7*	IPB60R360CFD7*	IPA60R360CFD7*			IPD60R360CFD7*	

600 V CoolMOST™ C7 Gold (G-series) **ACTIVE & PREFERRED**

$R_{DS(on)}$ [mΩ]	TO -220	TO-Leadless (TOLL)	TO-220 FullPAK	TO-247	TO-247 4-pin	TO-252 (Double DPAK)	ThinPAK 8x8
28		IPT60R028G7					
50		IPT60R050G7				IPDD60R050G7	
80		IPT60R080G7				IPDD60R080G7	
102		IPT60R102G7				IPDD60R102G7	
125		IPT60R125G7				IPDD60R125G7	
150		IPT60R150G7				IPDD60R150G7	
190						IPDD60R190G7	

www.infineon.com/coolmos

www.infineon.com/600v-p7

www.infineon.com/g7

*Coming soon

600 V CoolMOST™ C7 **ACTIVE & PREFERRED**

$R_{DS(on)}$ [mΩ]	TO-220	TO-263 (D ² PAK)	TO-220 FullPAK	TO-247	TO-247 4-pin	TO-252 (DPAK)	ThinPAK 8x8
17				IPW60R017C7	IPZ60R017C7		
40	IPP60R040C7	IPB60R040C7		IPW60R040C7	IPZ60R040C7		
60	IPP60R060C7	IPB60R060C7	IPA60R060C7	IPW60R060C7	IPZ60R060C7		
65							IPL60R065C7
99	IPP60R099C7	IPB60R099C7	IPA60R099C7	IPW60R099C7	IPZ60R099C7		
104							IPL60R104C7
120	IPP60R120C7	IPB60R120C7	IPA60R120C7	IPW60R120C7			
125							IPL60R125C7
180	IPP60R180C7	IPB60R180C7	IPA60R180C7	IPW60R180C7		IPD60R180C7	
185							IPL60R185C7

600 V CoolMOST™ P6 **ACTIVE**

$R_{DS(on)}$ [mΩ]	TO-220	TO-220 FullPAK	TO-247	TO-247 4-pin	TO-252 (DPAK)	ThinPAK 5x6	ThinPAK 8x8
41			IPW60R041P6				
70			IPW60R070P6	IPZ60R070P6			
99	IPP60R099P6	IPA60R099P6	IPW60R099P6	IPZ60R099P6			
125	IPP60R125P6	IPA60R125P6	IPW60R125P6				
160	IPP60R160P6	IPA60R160P6	IPW60R160P6				
180							IPL60R180P6
190	IPP60R190P6	IPA60R190P6	IPW60R190P6				
210							IPL60R210P6
230		IPA60R230P6					
255							
280	IPP60R280P6	IPA60R280P6	IPW60R280P6				
330/360						IPL60R360P6S	
380		IPA60R380P6			IPD60R380P6		
600		IPA60R600P6			IPD60R600P6		
650						IPL60R650P6S	

www.infineon.com/coolmos

www.infineon.com/c7

www.infineon.com/p6

600 V CoolMOST™ CE **ACTIVE**

$R_{DS(on)}$ [mΩ]	TO-220 FullPAK	TO-220 FullPAK Wide Creepage	TO-247	TO-252 (DPAK)	TO-251 (IPAK)	TO-251 (IPAK Short Lead)	SOT-223	TO-220 FullPAK Narrow Lead
190		IPAW60R190CE						
280		IPAW60R280CE						
380		IPAW60R380CE						
400	IPA60R400CE			IPD60R400CE		IPS60R400CE		
460	IPA60R460CE			IPD60R460CE		IPS60R460CE		
600		IPAW60R600CE						
650	IPA60R650CE			IPD60R650CE		IPS60R650CE		IPAN60R650CE
800				IPD60R800CE		IPS60R800CE		IPAN60R800CE
1000	IPA60R1K0CE			IPD60R1K0CE	IPU60R1K0CE	IPS60R1K0CE	IPN60R1K0CE	
1500	IPA60R1K5CE			IPD60R1K5CE	IPU60R1K5CE	IPS60R1K5CE	IPN60R1K5CE	
2100				IPD60R2K1CE	IPU60R2K1CE	IPS60R2K1CE	IPN60R2K1CE	
3400				IPD60R3K4CE		IPS60R3K4CE	IPN60R3K4CE	

500 V CoolMOST™ CE **ACTIVE & PREFERRED**

$R_{DS(on)}$ [mΩ]	TO-220	TO-220 FullPAK	TO-247	TO-252 (DPAK)	TO-251 (IPAK)	TO-251 (IPAK Short Lead)	SOT-223	TO-220 FullPAK Narrow Lead
190	IPP50R190CE	IPA50R190CE						
280	IPP50R280CE	IPA50R280CE		IPD50R280CE				
380	IPP50R380CE	IPA50R380CE		IPD50R380CE				
500		IPA50R500CE		IPD50R500CE				IPAN50R500CE
650				IPD50R650CE			IPN50R650CE	
800		IPA50R800CE		IPD50R800CE			IPN50R800CE	
950		IPA50R950CE		IPD50R950CE			IPN50R950CE	
1400				IPD50R1K4CE			IPN50R1K4CE	
2000				IPD50R2K0CE			IPN50R2K0CE	
3000				IPD50R3K0CE			IPN50R3K0CE	

www.infineon.com/coolmos

www.infineon.com/ce

www.infineon.com/500v-ce

CoolMOST™ SJ MOSFET automotive

650 V CoolMOST™ CFDA ACTIVE & PREFERRED							
Product type	$R_{DS(on)}$ @ $T_j = 25^\circ\text{C}$ $V_{GS} = 10\text{ V}$ [mΩ]	$I_{D,max}$ @ $T_j = 25^\circ\text{C}$ [A]	$I_{D,puls,max}$ [A]	$V_{GS(th),min-max}$ [V]	$Q_{G,typ}$ [nC]	$R_{thJC,max}$ [K/W]	Package
IPD65R420CFDA	420	8.7	27	3.5...4.5	32	1.5	TO-252
IPD65R660CFDA	660	6	17	3.5...4.5	20	2	TO-252
IPB65R110CFDA	110	31.2	99.6	3.5...4.5	11	0.45	TO-263
IPB65R150CFDA	150	22.4	72	3.5...4.5	86	0.64	TO-263
IPB65R190CFDA	190	17.5	57.2	3.5...4.5	68	0.83	TO-263
IPB65R310CFDA	310	11.4	34.4	3.5...4.5	41	1.2	TO-263
IPB65R660CFDA	660	6	17	3.5...4.5	20	2	TO-263
IPP65R110CFDA	110	31.2	99.6	3.5...4.5	11	0.45	TO-220
IPP65R150CFDA	150	22.4	72	3.5...4.5	86	0.64	TO-220
IPP65R190CFDA	190	17.5	57.2	3.5...4.5	68	0.83	TO-220
IPP65R310CFDA	310	11.4	34.4	3.5...4.5	41	1.2	TO-220
IPW65R048CFDA	48	63.3	228	3.5...4.5	27	0.25	TO-247
IPW65R080CFDA	80	43.3	127	3.5...4.5	16	0.32	TO-247
IPW65R110CFDA	110	31.2	99.6	3.5...4.5	11	0.45	TO-247
IPW65R150CFDA	150	22.4	72	3.5...4.5	86	0.64	TO-247
IPW65R190CFDA	190	17.5	57.2	3.5...4.5	68	0.83	TO-247

600 V CoolMOST™ CPA ACTIVE							
Product type	$R_{DS(on)}$ @ $T_j = 25^\circ\text{C}$ $V_{GS} = 10\text{ V}$ [mΩ]	$I_{D,max}$ @ $T_j = 25^\circ\text{C}$ [A]	$I_{D,puls,max}$ [A]	$V_{GS(th),min-max}$ [V]	$Q_{G,typ}$ [nC]	$R_{thJC,max}$ [K/W]	Package
IPB60R099CPA	99	31	93	2.5 ... 3.5	60	0.5	TO-263
IPB60R199CPA	199	16	51	2.5 ... 3.5	32	0.9	TO-263
IPB60R299CPA	299	11	34	2.5 ... 3.5	22	1.3	TO-263
IPP60R099CPA	99	31	93	2.5 ... 3.5	60	0.5	TO-220
IPW60R045CPA	45	60	230	2.5 ... 3.5	150	0.29	TO-247
IPW60R075CPA	75	39	130	2.5 ... 3.5	87	0.4	TO-247
IPW60R099CPA	99	31	93	2.5 ... 3.5	60	0.5	TO-247
IPW60R099CPA	99	31	93	2.5 ... 3.5	60	0.5	TO-262

800 V CoolMOST™ C3A ACTIVE & PREFERRED							
Product type	$R_{DS(on)}$ @ $T_j = 25^\circ\text{C}$ $V_{GS} = 10\text{ V}$ [mΩ]	$I_{D,max}$ @ $T_j = 25^\circ\text{C}$ [A]	$I_{D,puls,max}$ [A]	$V_{GS(th),min-max}$ [V]	$Q_{G,typ}$ [nC]	$R_{thJC,max}$ [K/W]	Package
IPD80R2K7C3A	2700	2	6	2.1 ... 3.9	12	3	TO-252
IPB80R290C3A	290	17	51	2.1 ... 3.9	91	0.55	TO-263
IPW80R290C3A	290	17	51	2.1 ... 3.9	91	0.55	TO-247

www.infineon.com/coolmos
www.infineon.com/coolmos-automotive
www.infineon.com/cfda

CoolMOS™ SJ MOSFETs – packages



SOT-223

Voltage [V]	Series	$R_{DS(on)}$ [mΩ]									
		0-59	60-89	90-149	150-199	200-299	300-400	401-600	601-899	900-1500	>1500
500	CE								650/800	950/1400	2000/3000
600	P7						360	600			
	CE									1000/1500	2100/3400
650	CE									1500	
700	P7						360	450/600	700	900/1200/1400	2000
	CE									1000/1500/2100	
800	P7								650/750	900/1200/1400	2000/2400/3300/4500
950	P7									1200	2000/3700



TO-247

Voltage [V]	Series	$R_{DS(on)}$ [mΩ]									
		0-59	60-89	90-149	150-199	200-299	300-400	401-600	601-899	900-1500	>1500
600	P7	24/37/45	60/80	99/120	180						
	C7	17/40	60	99/120	180						
	P6	41	70	99/125	160/190	280					
	CFD7	31/40/55	70	90/125	170						
	CPA	45	75	99							
650	C7	19/45	65	95/125	190						
	CFD2	41	80	110	150/190			420			
	CFDA	48	80	110	150/190						
800	P7					280	360				
	C3		85			290		450			
900	C3			120			340	500			



TO-247 4-pin

Voltage [V]	Series	$R_{DS(on)}$ [mΩ]									
		0-59	60-89	90-149	150-199	200-299	300-400	401-600	601-899	900-1500	>1500
600	C7	17/40	60	99							
	P6		70	99							
650	C7	19/45	65	95							



TO-247 4-pin asymmetric leads

Voltage [V]	Series	$R_{DS(on)}$ [mΩ]									
		0-59	60-89	90-149	150-199	200-299	300-400	401-600	601-899	900-1500	>1500
600	P7	24/37/45	60/80	99/120	180						



IPAK

Voltage [V]	Series	$R_{DS(on)}$ [mΩ]									
		0-59	60-89	90-149	150-199	200-299	300-400	401-600	601-899	900-1500	>1500
600	CE									1000/1500	2100
800	P7							600	750	900/1200/1400	2000/2400/3300/4500
	CE									1000	
950	P7							450	750	1200	2000/3700

www.infineon.com/coolmos-latest-packages

ACTIVE & PREFERRED



IPAK Short Lead

Voltage [V]	Series	$R_{DS(on)}$ [mΩ]									
		0-59	60-89	90-149	150-199	200-299	300-400	401-600	601-899	900-1500	>1500
600	CE						400	460	650/800	1000/1500	2100/3400
650	CE						400		650	1000	
700	P7						360/600			900/1400	
	CE									950/1400	2000
800	P7							600	750	900/1200/1400	2000/2400



IPAK Short Lead with ISO Standoff

Voltage [V]	Series	$R_{DS(on)}$ [mΩ]									
		0-59	60-89	90-149	150-199	200-299	300-400	401-600	601-899	900-1500	>1500
700	P7						360	450/600	750	900/1200/1400	2000
	CE							600		950/1400	2000



DPAK

Voltage [V]	Series	$R_{DS(on)}$ [mΩ]									
		0-59	60-89	90-149	150-199	200-299	300-400	401-600	601-899	900-1500	>1500
500	CE					280	380	500	650/800	950/1400	2000/3000
600	P7				180	280	360	600			
	C7				180						
	CE						400	460	650/800	1000/1500	2100/3400
650	P6						380	600			
	CFD7				170	280	360*				
	C7				190	225					
	CE						400		650	1000/1500	
	CFD2							420	660	950/1400	
700	CFDA							420	660		
	P7						360	600		900/1400	
	CE							600		950/1400	2000
800	P7					280	360	450/600	750	900/1200/1400	2000/2400
	C3									900/1300	2700
	CE									1000/1400	2800
900	C3									1200	
950	P7							450	750	1200	2000

I²PAK

Voltage [V]	Series	$R_{DS(on)}$ [mΩ]									
		0-59	60-89	90-149	150-199	200-299	300-400	401-600	601-899	900-1500	>1500
600	CPA			99							
650	CFD2				199						
700	CE									950	
900	C3						340	500		1200	

D²PAK

Voltage [V]	Series	R _{DS(on)} [mΩ]									
		0-59	60-89	90-149	150-199	200-299	300-400	401-600	601-899	900-1500	>1500
600	C7	40	60	99/120	180						
	P7	45	60/80	99/120	180	280	360				
	CPA			99	199	299					
	CFD7	40* 55*	70*	20*/105* 125*/145*	170*	210* 280*	360*				
650	C7	45	65	95/125	190	225					
	CFD2			110	150/190		310				
	CFDA			110	150/190		310	660			
800	C3					290					
900	C3						340				



Double DPAK (DDPAK)

Voltage [V]	Series	R _{DS(on)} [mΩ]									
		0-59	60-89	90-149	150-199	200-299	300-400	401-600	601-899	900-1500	>1500
600	G7	50	80	102/125	150/190						



TO-220 FullPAK

Voltage [V]	Series	R _{DS(on)} [mΩ]									
		0-59	60-89	90-149	150-199	200-299	300-400	401-600	601-899	900-1500	>1500
500	CE				190	280	380	500	800	950	
600	P7		60/80	99/120	160/180	280	360	600			
	C7		60	99/120	180						
	CE						400	460	650	1000/1500	
	CFD7			125	170	280	360*				
650	P6			99/125	160/190	230/280	380	600			
	C7	45	65	95/125	190	225					
	CE						400		650	1000/1500	
700	CFD2			110	150/190		310	420	660		
800	P7						360	450/600	750	900	
	P7					280	360	450/600	750	900/1200/1400	
	C3					290		450	650	900/1300	2700
900	CE						310	460	650	1000/1400	
	C3							340	500	800	1000/1200
950	P7							450	750	1200	



TO-220 FullPAK Narrow Lead

Voltage [V]	Series	R _{DS(on)} [mΩ]									
		0-59	60-89	90-149	150-199	200-299	300-400	401-600	601-899	900-1500	>1500
500	CE							500			
600	CE								650/800		
	P7				180	280	360	600			
650	CE								650		
700	P7						360	450/600	750	900	
800	P7					280	360	450			



TO-leadless

Voltage [V]	Series	R _{DS(on)} group [mΩ]									
		0-59	60-89	90-149	150-199	200-299	300-400	401-600	601-899	900-1500	>1500
600	G7	28/50	80	102/125	150						
650	G7	33		105	195						



TO-220

Voltage [V]	Series	$R_{DS(on)}$ [mΩ]									
		0-59	60-89	90-149	150-199	200-299	300-400	401-600	601-899	900-1500	>1500
500	CE				190	280	380				
600	P7		60/80	99/120	160/180	280	360	600			
	C7	40	60	99/120	180						
	P6			99/125	160/190	280					
	CFD7		70	90/125	170	280	360*				
	CPA			99							
650	C7	45	65	95/125	190	225					
	CFD2			110	150/190		310	420			
	CFDA			110	150/190		310		660		
800	P7					280	360	450/600	750	900/1200/1400	
	C3					290		450	650	900/1300	
900	C3						340		800	1000/1200	



TO-220 FullPAK Wide Creepage

Voltage [V]	Series	$R_{DS(on)}$ [mΩ]									
		0-59	60-89	90-149	150-199	200-299	300-400	401-600	601-899	900-1500	>1500
600	P7				180	280	360	600			
	CE				190	280	380	600			
700	CE							600		950	



ThinPAK 5x6

Voltage [V]	Series	$R_{DS(on)}$ [mΩ]									
		0-59	60-89	90-149	150-199	200-299	300-400	401-600	601-899	900-1500	>1500
600	P6						360		650		
700	P7							600	750	900/1200/1400	2000
800	P7							600	750	900/1200/1400	2000



ThinPAK 8x8

Voltage [V]	Series	$R_{DS(on)}$ [mΩ]									
		0-59	60-89	90-149	150-199	200-299	300-400	401-600	601-899	900-1500	>1500
600	P7		65/85	105/125	185	285	365				
	C7		65	104/125	185						
	CFD7		75		185	225*					
	P6				180	210					
650	C7		70	99/130	195	230					
	CFD2				165	210	340				

Nomenclature

Power MOSFETs (until 2005)

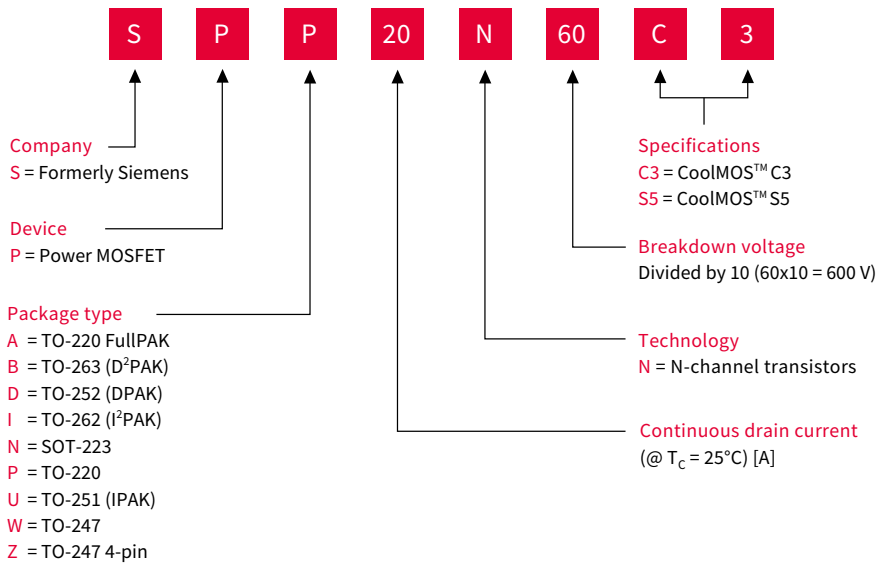

Power MOSFETs (from October 2015 onwards)

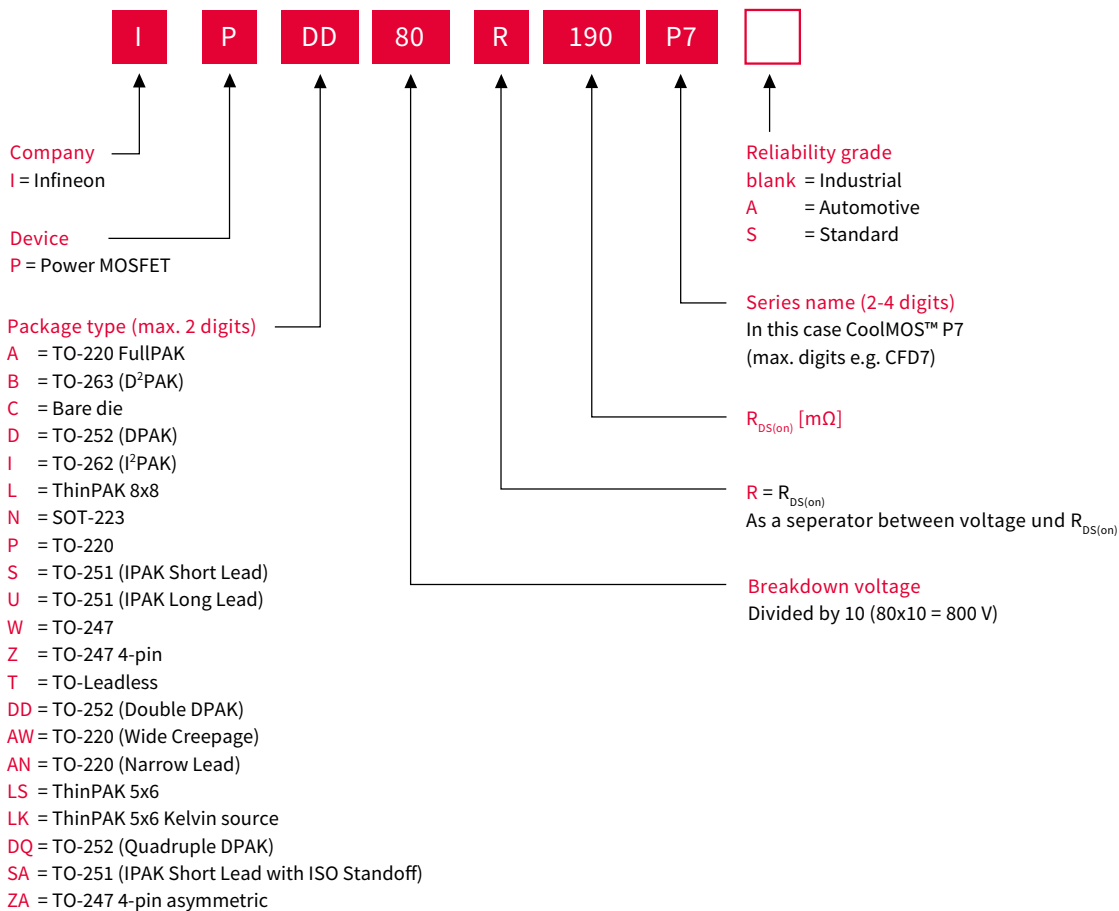

Automotive MOSFETs

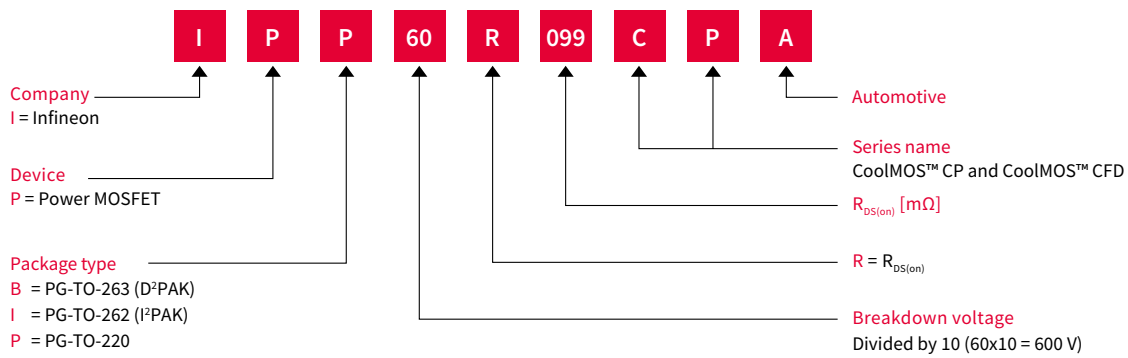



Infineon support for high voltage MOSFETs

Useful links and helpful information

Further information, datasheets and documents

www.infineon.com/coolmos

www.infineon.com/coolmos-latest-packages

www.infineon.com/coolmos-automotive

Evaluationboards and simulation models

www.infineon.com/coolmos-boards

www.infineon.com/powermosfet-simulationmodels

Videos

www.infineon.com/mediacenter



Wide bandgap semiconductors

Gallium nitride (GaN) and silicon carbide (SiC)

The key to the next essential step towards an energy-efficient world is to use new materials, such as wide bandgap semiconductors that allow for greater power efficiency, smaller size, lighter weight, lower overall cost – or all of these together. Infineon Technologies, with its unique market position of being currently the only company offering silicon (Si), silicon carbide (SiC) and gallium nitride (GaN) devices, is the customer's first choice in all segments.

CoolGaN™ – ultimate efficiency and reliability

Compared to silicon (Si), the breakdown field of Infineon's CoolGaN™ enhancement mode (e-mode) HEMTs is ten times higher and the electron mobility is double. Both the output charge and gate charge are ten times lower than with Si and the reverse recovery charge is almost zero which is key to high frequency operations. GaN is the best-suited technology in hard switching as well as resonant topologies, and is enabling new approaches in current modulation. Infineon's GaN solution is based on the most robust and performing concept in the market – the enhancement mode concept - offering fast turn-on and turn-off speed. CoolGaN™ products focus on high performance and robustness, and add significant value to a broad variety of systems across many applications such as server, telecom, hyperscale data centers, wireless charging, adapter/charger, and audio. CoolGaN™ switches are easy to design-in with the matching GaN EiceDRIVER™ gate driver ICs from Infineon.

CoolSiC™ - revolution to rely on

Silicon carbide (SiC) has a wide bandgap of 3 electronvolt (eV) and a much higher thermal conductivity compared to silicon. SiC-based MOSFETs are best-suited for high-breakdown, high-power applications that operate at higher frequencies compared to traditional IGBTs. CoolSiC™ MOSFETs come along with a fast internal freewheeling diode, thus making hard switching without additional diode chips possible. Due to its unipolar character, the MOSFETs show very low, temperature-independent switching and low conduction losses, especially under partial load conditions. Based on proven, high quality volume manufacturing, Infineon's CoolSiC™ solutions combine revolutionary technology with benchmark reliability – for our customers' success today and tomorrow. The offering is completed by selected driver ICs based on Infineon's successful coreless transformer technology.



CoolGaN™ e-mode HEMTs

Tailor-made for the highest efficiency and power density in switch mode power supplies

In comparison to the next best silicon alternative, CoolGaN™ enables higher power density and the highest efficiency, especially in the partial load range, through novel topologies such as the CCM totem pole PFC stage. GaN e-mode HEMT performance features low reverse recovery charge and excellent dynamic performance in reverse conduction compared to silicon FET solutions. This enables more efficient operation at established frequencies, and much higher frequency operation which can improve power density by shrinking the size of passive components. CoolGaN™ enables doubled output power in a given energy storage slot size, freeing up space and realizing higher efficiency at the same time.

Infinion's CoolGaN™ comes with industry leading reliability. During the quality management process, it is not only the device which is thoroughly tested but also its behavior in the application environment. The performance of CoolGaN™ goes beyond other GaN products in the market.

Features

- › Low output charge and gate charge
- › No reverse recovery charge

Design benefits

- › High power density, small and light design
- › High efficiency in resonant circuits
- › New topologies and current modulation
- › Fast and (near-)lossless switching

Advantages

- › Operational expenses (OPEX) and capital expenditure (CAPEX) reduction
- › BOM and overall cost savings

Infinion leverages its unique portfolio of high and low voltage MOSFETs, driver ICs and digital controllers to complement its CoolGaN™ product line, thus enabling full exploit for GaN benefits.

The highest quality

The qualification of GaN switches requires a dedicated approach, well beyond existing silicon standards

- › Infineon qualifies GaN devices well beyond industry standards
- › Application profiles are an integral part of the qualification
- › Failure models, based on accelerated test conditions, ensure target lifetime and quality are met
- › Infineon sets the next level of wide bandgap quality

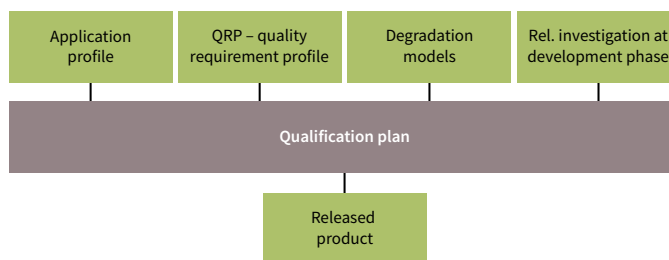

CoolGaN™ e-mode HEMTs overview

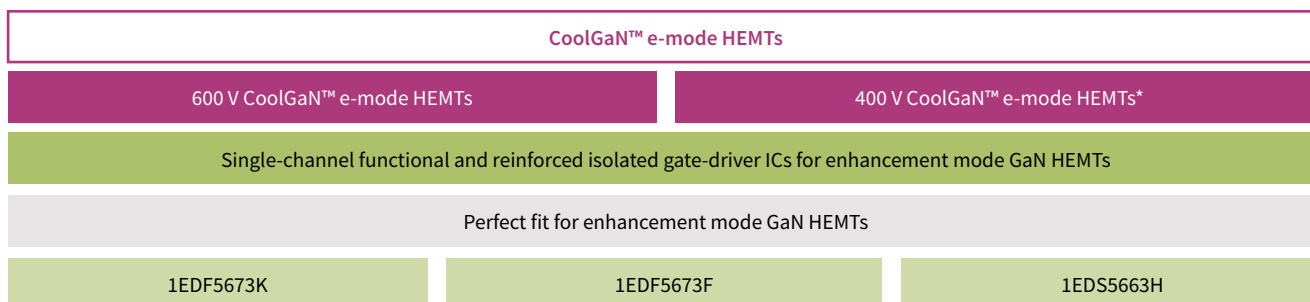

www.infineon.com/gan

* Coming soon

CoolGaN™ 400 V and 600 V e-mode GaN HEMTs – bringing GaN technology to the next level

Infiniteon's CoolGaN™ 400 V* and 600 V e-mode HEMTs enable more than 98 percent system efficiency and help customers to make their end products smaller and lighter. Driving enhancement mode devices requires some additional features when choosing the correct gate driver IC, however CoolGaN™ technology does not require customized ICs. Infineon offers three new members of a single-channel galvanic isolated gate driver IC family. The new components are a perfect fit for e-mode GaN HEMTs with non-isolated gate (diode input characteristic) and low threshold voltage, such as CoolGaN™.

Complete support of all requirements specific to e-mode GaN HEMTs operation:

- › Low driving impedance (on-resistance 0.85 Ω source, 0.35 Ω sink)
- › Resistor programmable gate current for steady on-state (typically 10 mA)
- › Programmable negative gate voltage to completely avoid spurious turn-on in half-bridges

Block diagram: high-efficiency GaN switched mode power supply (SMPS)

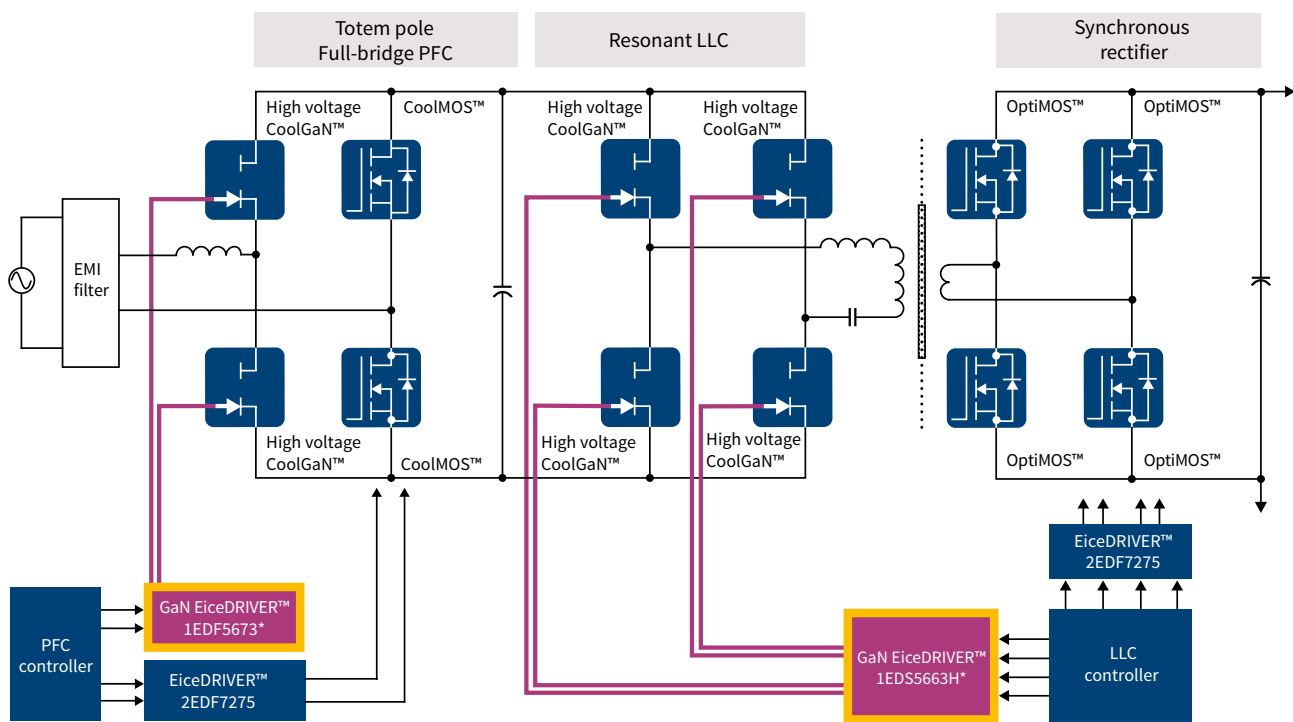

*GaN EiceDRIVER™ ICs are single-channel products

CoolGaN™ 400 V* e-mode GaN HEMTs

Class D output stage offering the best audio experience

CoolGaN™ 400 V enables smoother switching and more linear class D output stage by offering low/linear C_{oss} , zero Q_{rr} , and normally-off switch. Ideal class D audio amplifiers offer 0 percent distortion and 100 percent efficiency. What impairs the linearity and power loss is highly dependent on switching characteristics of the switching device. Infineon's CoolGaN™ 400 V breaks through the technology barrier by introducing zero reverse recovery charge in the body diode and very small, linear input and output capacitances.

In addition, the e-mode concept offers fast turn-on and turn-off speed. This feature also simplifies pairing CoolGaN™ with the IRS20957S class D controller and therefore enables faster go-to-market.

CoolGaN™ for class D audio solutions

CoolGaN™ 400 V is tailored for premium HiFi home audio, professional, and aftermarket car audio systems where end users demand every detail of their high resolution sound tracks. These have been conventionally addressed by bulky linear amplifiers or tube amplifiers. With CoolGaN™ 400 V as the class D output stage, audio designers will be able to deliver the best audio experience to their prospective audio fans.

CoolGaN™ 400 V devices in PG-DSO-20-87 and PG-TOLL package have been tested in class D audio amplifier applications on 300 W+300 W dual-channel system designs.

Key features

- › Ultralow and linear C_{oss} 400 V power devices
- › Zero Q_{rr}
- › E-mode transistor – normally-off switch

Key benefits

- › Clean switching performance
- › Narrow dead time for better THD
- › Easy to use: compatible with the IRS20957S class D audio control IC

400 V CoolGaN™ benefits from the engineering expertise Infineon has made towards challenging applications, such as telecom rectifiers and SMPS servers, where CoolGaN™ technology proved to be highly reliable. It is the most robust and performing concept in the market. The 400 V CoolGaN™ portfolio is built around class D Audio requirements, with high performing SMD packages to fully exploit the benefits of GaN technology.

www.infineon.com/gan

* Coming soon

CoolGaN™ 600 V e-mode GaN HEMTs

The highest efficiency and power density with reduced system costs

The e-mode concept offers fast turn-on and turn-off speed, as well as a better path towards integration. CoolGaN™ 600 V e-mode HEMTs enable simpler and more cost-effective half-bridge topologies. As e-mode based products reach maturity, CoolGaN™ 600 V HEMTs are gaining growing prominence thanks to their potential. The CoolGaN™ 600 V series is manufactured according to a specific, GaN-tailored qualification process which goes far beyond the standards for silicon power devices. CoolGaN™ 600 V is designed for datacom and server SMPS, telecom rectifiers, as well as mobile chargers and can be used as a general switch in many other industrial and consumer applications. It is the most rugged and reliable solution in the market. The CoolGaN™ portfolio is built around high performing SMD packages to fully exploit the benefits of GaN.

CoolGaN™ for PFC

CoolGaN™ enables the adoption of simpler half-bridge topologies (including elimination of the lossy input bridge rectifier). The result is record efficiency (>99%) with a potential for BOM savings.

CoolGaN™ for resonant topologies

- › In resonant applications, ten times lower Q_{oss} and Q_g enables high frequency operations (>1 MHz) at the highest efficiency levels
- › Linear output capacitance leads to 8 to 10 times lower dead time
- › Devices can be easily paralleled
- › Power density can be pushed even further by optimizing the thermal performance
- › CoolGaN™ enables to push the efficiency forward, thus enabling high power density e.g., in low power chargers

Applications

- › Telecom
- › Server
- › Datacom
- › Adapter and charger
- › Wireless charging
- › SMPS

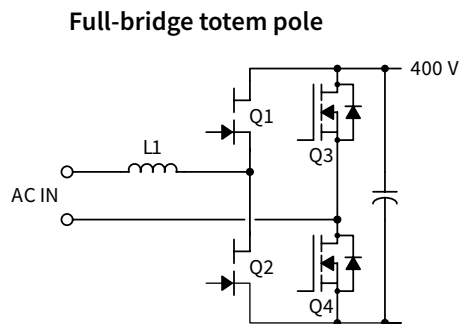

Demonstration board

2.5 kW totem pole PFC board:
EVAL_2500W_PFC_GAN_A



- › 2 x 70 mΩ CoolGaN™ in DSO-20 BSC
- › 2 x 33 mΩ CoolMOS™

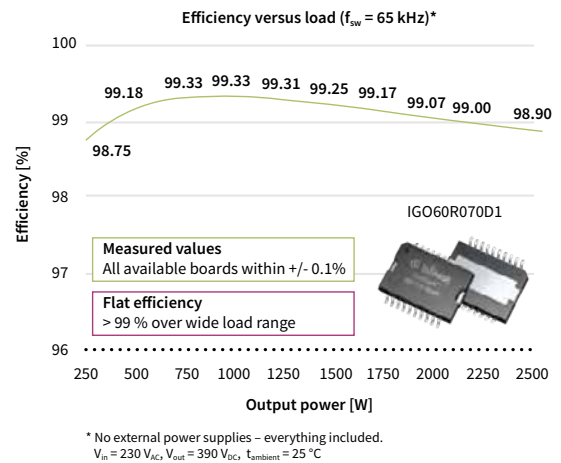

CoolGaN™ 400 V e-mode GaN HEMTs



Package	DSO-20-87 Top-side cooling	HSOF-8-3 (TO-leadless)
P_{max}	up to 500 W	up to 200 W
$R_{DS(on)}$	70 mΩ	IGT40R070D1**

CoolGaN™ 600 V e-mode GaN HEMTs



Package	DSO-20-85 Bottom-side cooling	DSO-20-87 Top-side cooling	HSOF-8-3 TO-leadless	LSON-8-1 DFN 8x8
$R_{DS(on)}$	35 mΩ	IGOT60R035D1**	IGT60R035D1**	
	70 mΩ	IGO60R070D1	IGT60R070D1	IGLD60R070D1
			IGT60R190D1S*	IGLD60R190D1**
			IGT60R190D1**	
				IGLD60R340D1**

Infiniteon's CoolGaN™ devices, driven by single-channel isolated gate driver ICs from the GaN EiceDRIVER™ family, aim to unlock the full potential of GaN technology.

GaN EiceDRIVER™ family product portfolio



Product	Package	Input to output isolation				Propagation delay accuracy	Typ. high level (sourcing) output resistance	Typ. low level (sinking) output resistance	SP number
		Isolation class	Rating	Surge testing	Certification				
1EDF5673K	LGA, 13-pin, 5x5 mm	functional	$V_{IO} = 1.5 \text{ kV}_{DC}$	n.a.	n.a.	-6 ns/+7ns	0.85 Ω	0.35 Ω	SP002447622
1EDF5673F	DSO, 16-pin, 150 mil	functional	$V_{IO} = 1.5 \text{ kV}_{DC}$	n.a.	n.a.	-6 ns/+7ns	0.85 Ω	0.35 Ω	SP003194020
1EDS5663H	DSO, 16-pin, 300 mil	reinforced	$V_{IO} = 8 \text{ kV}_{pk}$ $V_{ISO} = 5.7 \text{ kV}_{rms}$	$V_{ISOM} > 10 \text{ kV}_{pk}$	VDE0884-10 UL1577	-6 ns/+7ns	0.85 Ω	0.35 Ω	SP002753980

www.infineon.com/gan

www.infineon.com/gan-eicedriver

*Standard grade

** Coming soon



Nomenclature

CoolGaN™

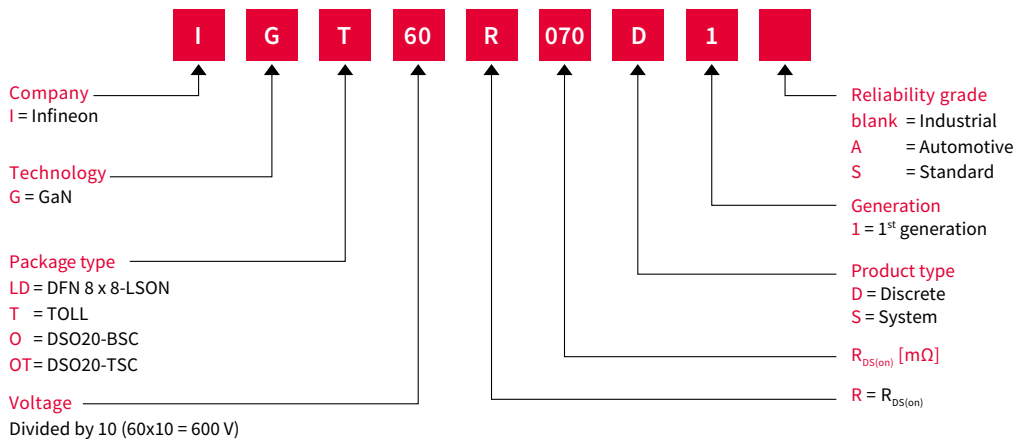

Silicon carbide

Improve efficiency and solution costs

Silicon carbide (SiC) devices belong to the so-called wide bandgap semiconductor group, which offers a number of attractive characteristics for high voltage power semiconductors when compared to commonly used silicon (Si). In particular, the much higher breakdown field strength and thermal conductivity of silicon carbide allow developing devices which by far outperform the corresponding silicon-based ones, and enable efficiency levels unattainable otherwise. Infineon's portfolio of SiC devices covers 600 V and 650 V to 1200 V Schottky diodes as well as the revolutionary CoolSiC™ MOSFET.

CoolSiC™ Schottky diodes

The differences in material properties between silicon carbide and silicon limit the fabrication of practical silicon unipolar diodes (Schottky diodes) to a range up to 100-150 V, with a relatively high on-state resistance and leakage current. In SiC, Schottky diodes can reach a much higher breakdown voltage. Infineon offers products up to 1200 V in discrete packages and up to 1700 V in modules.

Features

- › No reverse recovery charge
- › Purely capacitive switching
- › High operating temperature ($T_{j, \max}$ 175°C)

Advantages

- › Low turn-off losses
- › Reduction of CoolMOS™ or IGBT turn-on loss
- › Switching losses independent from load current, switching speed and temperature

Benefits

- › System efficiency improvement compared to Si diodes
- › Reduced cooling requirements
- › Enabling higher frequency/increased power density
- › Higher system reliability due to lower operating temperature
- › Reduced EMI

Applications

- › Server
- › Telecom
- › Solar
- › UPS
- › EV charging
- › Energy storage
- › PC power
- › Motor drives
- › Lighting
- › CAV

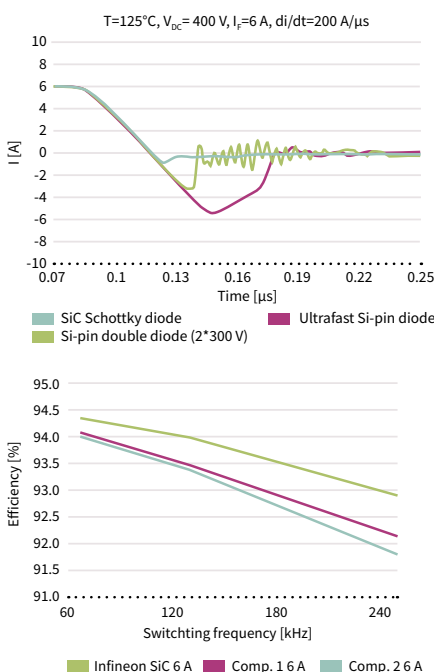

Reverse recovery charge of SiC Schottky diodes versus Si-pin diodes

The majority of carrier characteristics imply no reverse recovery charge and the only contribution to the switching losses comes from the tiny displacement charge of capacitive nature. In the same voltage range, silicon devices have a bipolar component resulting in much higher switching losses. The graph shows the comparison between various 600 V devices.

Improved system efficiency (PFC in CCM mode operation, full load, low line)

The fast switching characteristics of the SiC diodes provide clear efficiency improvements at system level. The performance gap between SiC and high-end silicon devices increases with the operating frequency.

www.infineon.com/sic

Infineon is the world's first SiC discrete power supplier. The long market presence and experience enable Infineon to deliver highly reliable, industry-leading SiC performance. With over 10 years pioneering experience in developing and manufacturing SiC diodes, Infineon's latest CoolSiC™ Schottky diode generation 6 family sets benchmark in quality, efficiency and reliability.

CoolSiC™ Schottky diodes 650 V

CoolSiC™ Schottky diodes 650 V G6 and G5

The new CoolSiC™ Schottky diode 650 V G6 product family is built over the strong characteristics of the previous generation G5, fully leveraging technology and process innovation to propose the best efficiency and zero price/ performance products to date.

Foundation technology – CoolSiC™ Schottky diodes 650 V G5

The established CoolSiC™ Schottky diodes G5 product family has been optimized after all key aspects including junction structure, substrate and die attach. It represents a well-balanced product family which offers state-of-the-art performance and high surge current capability at competitive cost level.

Innovation: optimized junction, substrate and die attach

Infineon's SiC Schottky diode generation 5 is optimized with regard to all key aspects relevant for high power and high efficiency SMPS applications.

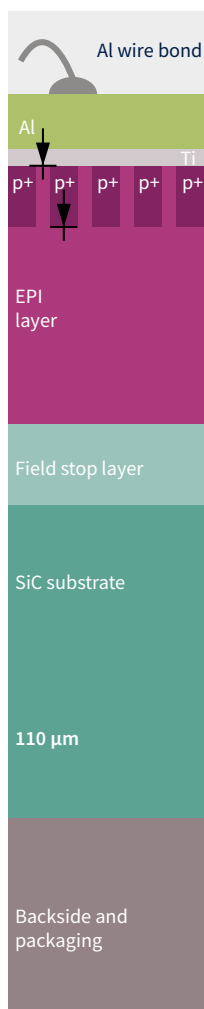

Junction: merged PN structure

On the junction level, it has an optimized merged PN structure. Compared to competitors, Infineon's SiC diode has additional P-doped area, which, together with the N-doped EPI layer, forms a PN junction diode. Thus, it is a combination of Schottky diode and PN junction diode. Under normal conditions it works like a standard Schottky diode. Under abnormal conditions such as lighting, AC line drop-out, it works like a PN junction diode. At high current level, the PN junction diode has significantly lower forward voltage (V_f) than Schottky diode, which leads to less power dissipation, thus significantly improving the surge current capability.

Substrate: thin wafer technology

On the substrate level, Infineon introduced thin wafer technology. At the later stage of our SiC diode production, thin wafer process is used to reduce the wafer thickness by about two-thirds, which significantly reduces the substrate resistance contribution, thus, improving both forward voltage (V_f) and thermal performance.

Die attach: diffusion soldering

On the backside, package level diffusion soldering is introduced, which significantly improves the thermal path between lead frame and the diode, enhancing the thermal performance. With the same chip size and power dissipation, the junction temperature is reduced by 30°C.

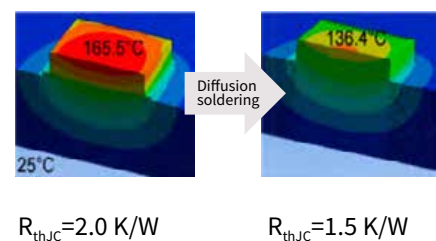
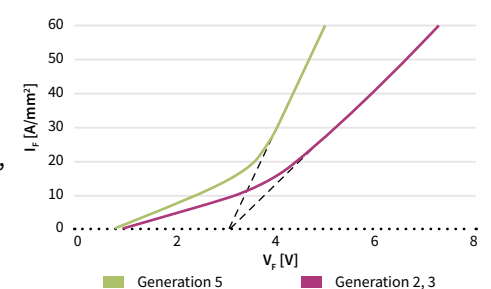
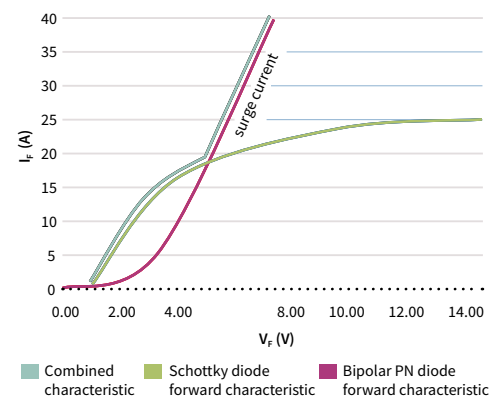

Latest development - CoolSiC™ Schottky diodes 650 V G6

On the top of these technologies, the CoolSiC™ Schottky diodes G6 product family introduces a novel and proprietary Schottky metal system. This contributes to the reduction of the forward voltage (V_F) to levels which are difficult, determining a measurable decrease of conduction losses.

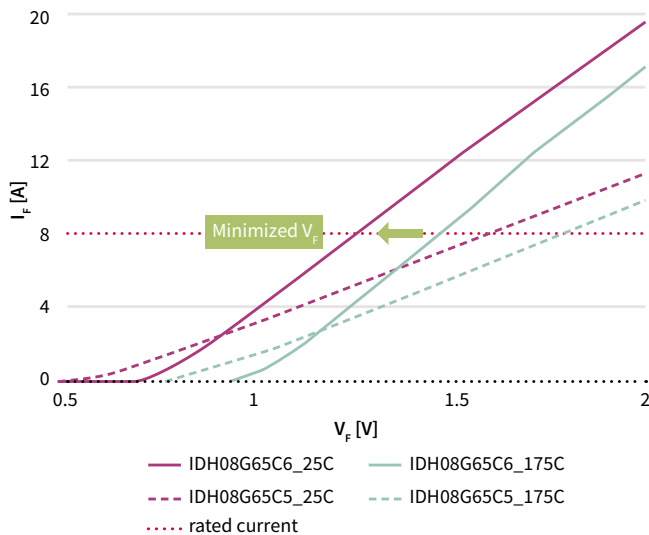

Infineon's CoolSiC™ Schottky diodes enable optimum efficiency and ruggedness. Lower forward voltage (V_F) means lower conduction loss, and lower capacitive charge (Q_c) means lower switching loss. $Q_c \times V_F$ is the figure of merit for efficiency, and comparison indicates that the latest generation 6 products have the lowest $Q_c \times V_F$ on the market. Infineon's CoolSiC™ Schottky diodes offer a surge current robustness far better than the one offered by the most efficient products. Thus, under abnormal conditions, this surge current capability offers excellent device robustness.

Efficiency comparison

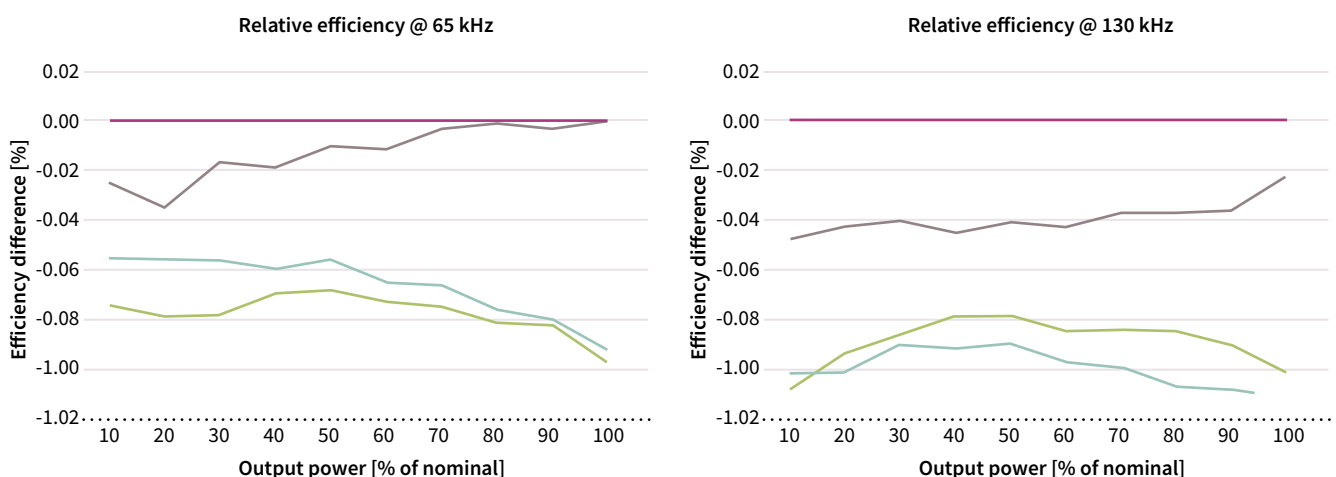

In terms of efficiency, the 8 A G6 device has been tested in CCM PFC. The maximum output power is 3.5 kW. The left figure shows the relative efficiency at 65 kHz, while the right figure shows the relative efficiency at 130 kHz. This shows that Infineon's CoolSiC™ Schottky diode G6 delivers better efficiency over the full load range, keeping this advantage even at 130 kHz, therefore meeting the needs of designers who want to increase the switching frequencies in their designs to attain more power density.

www.infineon.com/coolpic-g6



The best price performance

CoolSiC™ Schottky diodes G6 are the outcome of Infineon’s continuous technological and process improvements, enabling the design and development of SiC-based products, making them more price-competitive and increasing performance across generations. As a result, G6 is Infineon’s best price/performance CoolSiC™ Schottky diode generation, offering the highest cost-efficiency. In addition, Infineon offers the reliability of collaborating with the industry leader. Customers can leverage Infineon’s proven quality and supply chain reliability. They can benefit from “one-stop-shop” advantages and maximize system performance, combining CoolSiC™ Schottky diodes with the SJ MOSFETs of the CoolMOS™ 7 family, such as 600 V C7, 650 V C7, 600 V G7, 650 V G7 and 600 V P7.

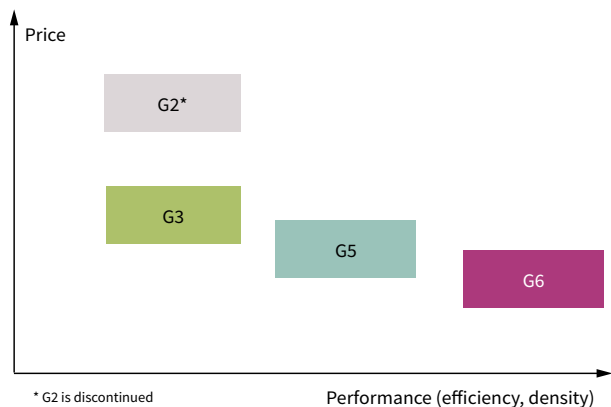

A comprehensive portfolio

The combined G6 and G5 650 V CoolSiC™ Schottky diode portfolio offers wide choice of packages and ampere class granularity to allow the best fit to application. G6 comes in double DPAK, the first top-side cooled surface mount package, which allows thermal decoupling of PCB to chip junction and enables higher power dissipation and improved system lifetime thanks to the reduced board temperature.

www.infineon.com/coolpic-g6

CoolSiC™ Schottky diodes 1200 V

New level of system efficiency and reliability

By using hybrid Si power switch/SiC diode sets, designers of industrial applications will gain flexibility for system optimization compared to purely silicon-based solutions. System improvements by higher efficiency, higher output power or higher switching frequency are enabled by SiC diodes. Implementing CoolSiC™ diodes generation 5, for example in Vienna rectifier topology, in combination with Infineon's 650 V TRENCHSTOP™ IGBTs and 650 V CoolMOS™ MOSFETs, designers can achieve outstanding system level performance and reliability.

Key features of generation 5

- › Low forward voltage (V_F) - 1.4 V
- › Mild positive temperature dependency of V_F
- › High surge current capability up to fourteen times of the nominal current
- › Up to 40A-rated diode

Key benefits of 1200 V generation 5

- › Reduced cooling requirements through lower diode losses and lower case temperatures
- › High system reliability by extended surge current

650 V Si IGBT/Si SJ MOSFET and 1200 V SiC diode/ultrafast Si diode in a Vienna rectifier topology, $f_{sw}=48$ kHz

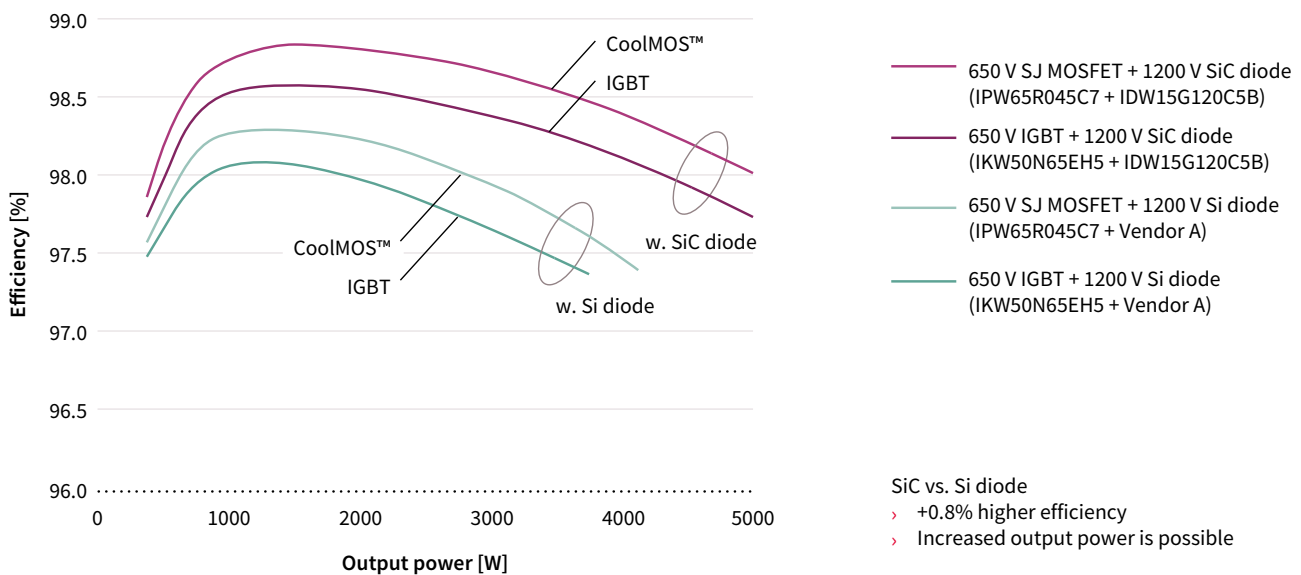

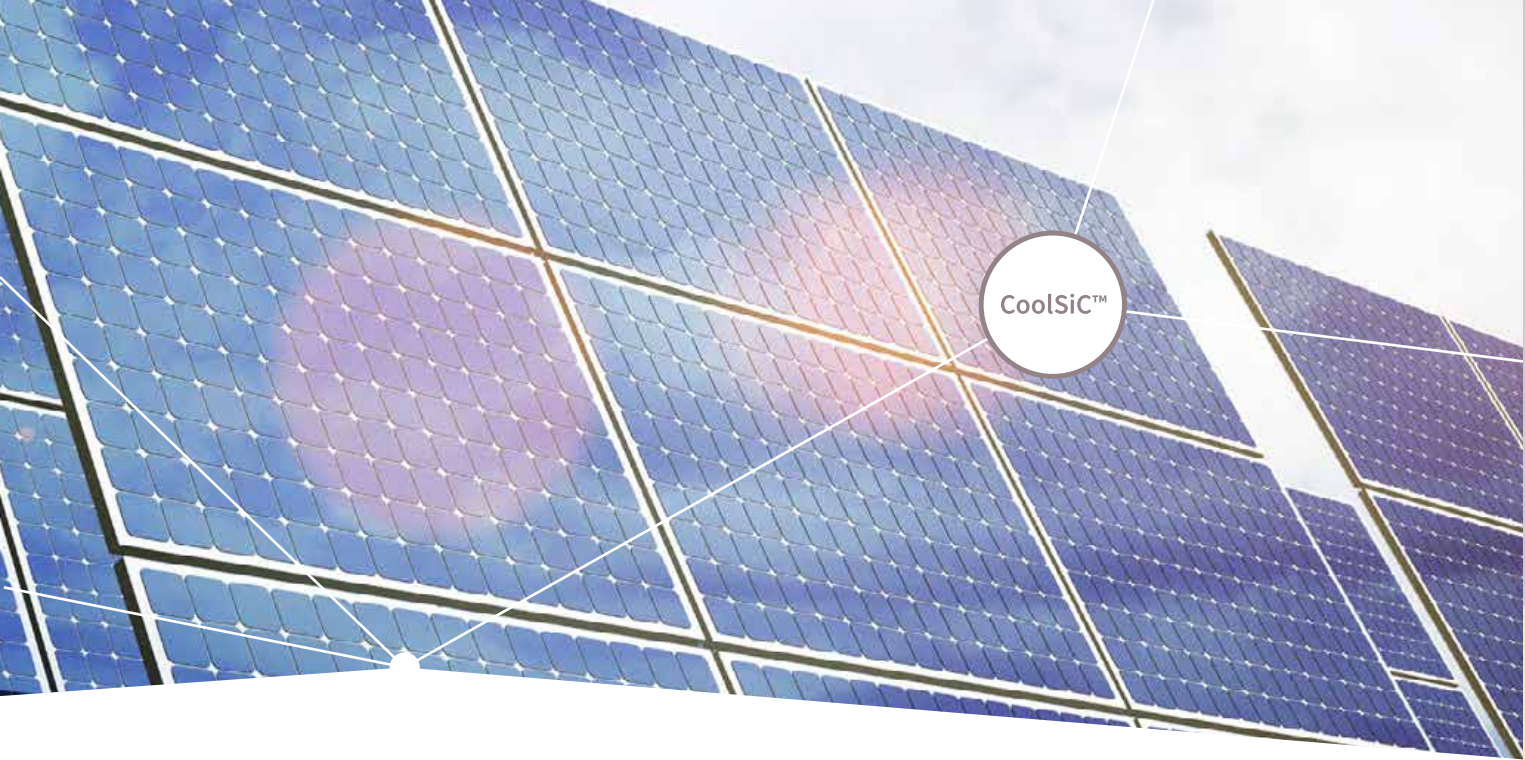

CoolSiC™ silicon carbide MOSFETs – revolution to rely on

Infineon's CoolSiC™ technology enables radically new product designs

Silicon carbide (SiC) opens up new degrees of freedom for designers to harness never before seen levels of efficiency and system flexibility. In comparison to traditional silicon-based switches like IGBTs and MOSFETs, the SiC MOSFET offers a series of advantages. These include the low switching losses with 1200 V switches, very low reverse recovery losses of the internal commutation proof body diode, temperature independent low switching losses, and threshold-free on-state characteristics. Based on volume experience and compatibility know-how, Infineon introduces the revolutionary SiC technology which enables radically new product designs with high performance and high reliability. CoolSiC™ MOSFET products are targeted for photovoltaic inverters, battery charging and energy storage.

CoolSiC™ MOSFET features

- › Revolutionary semiconductor material – silicon carbide
- › Very low switching losses
- › Threshold-free on-state characteristic
- › Wide gate-source voltage range
- › Benchmark gate threshold voltage, $V_{GS(th)} = 4.5\text{ V}$
- › Fully controllable dV/dt
- › Commutation robust body diode, ready for synchronous rectification
- › Temperature independent turn-off switching losses

Benefits

- › Best-in-class system performance
- › Efficiency improvement and reduced cooling effort
- › Significant reduction in junction temperature for longer lifetime and higher reliability
- › Enables higher frequency operation for reduction in system cost and shrink
- › Allows for increase in power density
- › Two-level topologies can replace three-level with same efficiency for lower complexity and cost
- › Excellent for hard switching and resonant switching topologies like LLC and ZVS

TO-247 4-pin package contains an additional connection to the source (Kelvin connection) that is used as a reference potential for the gate driving voltage, thereby eliminating the effect of voltage drops over the source inductance. The result is even lower switching losses than for TO-247 3-pin version, especially at higher currents and higher switching frequencies.

www.infineon.com/coolbic-mosfet

CoolSiC™ Schottky diodes 650 V G6 **ACTIVE & PREFERRED**

I_F [A]	TO-220 R2L	TO-247 Dual Die	TO-247	Double DPAK	D ² PAK R2L	ThinPAK 8x8
4	IDH04G65C6			IDDD04G65C6		
6	IDH06G65C6			IDDD06G65C6		
8	IDH08G65C6			IDDD08G65C6		
10	IDH10G65C6			IDDD10G65C6		
12	IDH12G65C6			IDDD12G65C6		
16	IDH16G65C6			IDDD16G65C6		
20	IDH20G65C6			IDDD20G65C6		

CoolSiC™ Schottky diodes 650 V G5 **ACTIVE**

I_F [A]	TO-220 R2L	TO-247 Dual Die	TO-247	D ² PAK R2L	ThinPAK 8x8
2	IDH02G65C5			IDK02G65C5	IDL02G65C5
3	IDH03G65C5			IDK03G65C5	
4	IDH04G65C5			IDK04G65C5	IDL04G65C5
5	IDH05G65C5			IDK05G65C5	
6	IDH06G65C5			IDK06G65C5	IDL06G65C5
8	IDH08G65C5			IDK08G65C5	IDL08G65C5
9	IDH09G65C5			IDK09G65C5	
10	IDH10G65C5		IDW10G65C5	IDK10G65C5	IDL10G65C5
12	IDH12G65C5		IDW12G65C5	IDK12G65C5	IDL12G65C5
16	IDH16G65C5		IDW16G65C5		
20	IDH20G65C5	IDW20G65C5B	IDW20G65C5		
24		IDW24G65C5B			
30/32		IDW32G65C5B	IDW30G65C5		
40		IDW40G65C5B	IDW40G65C5		

www.infineon.com/sic



Applications
20-300 V MOSFETs
500-950 V MOSFETs
WBG semiconductors
Discrete IGBTs
Power ICs
Gate driver ICs
Motor control ICs
Microcontrollers
XENSIV™ sensors
Packages

CoolSiC™ Schottky diodes 650 V G3 ACTIVE



I_F [A]	TO-220 R2L	TO-247 Dual Die	TO-247	DPAK R2L	D ² PAK	ThinPAK 8x8
3	IDH03SG60C			IDD03SG60C		
4	IDH04SG60C			IDD04SG60C		
5	IDH05SG60C			IDD05SG60C		
6	IDH06SG60C			IDD06SG60C		
8	IDH08SG60C			IDD08SG60C		
9	IDH09SG60C			IDD09SG60C		
10	IDH10SG60C			IDD10SG60C		
12	IDH12SG60C			IDD12SG60C		

CoolSiC™ Schottky diodes 1200 V G5 ACTIVE & PREFERRED



I_F [A]	TO-220 R2L	TO-247 Dual Die	TO-247 R2L	DPAK R2L
2	IDH02G120C5			IDM02G120C5
5	IDH05G120C5			IDM02G120C5
8	IDH08G120C5			IDM08G120C5
10	IDH10G120C5	IDW10G120C5B	IDWD10G120C5	IDM10G120C5
15/16	IDH16G120C5	IDW15G120C5B	IDWD15G120C5	
20	IDH20G120C5	IDW20G120C5B	IDWD20G120C5	
30		IDW30G120C5B	IDWD30G120C5	
40		IDW40G120C5B	IDWD40G120C5	

„B“ in product name refers to common-cathode configuration

Nomenclature

CoolSiC™ Schottky diodes G2 and G3

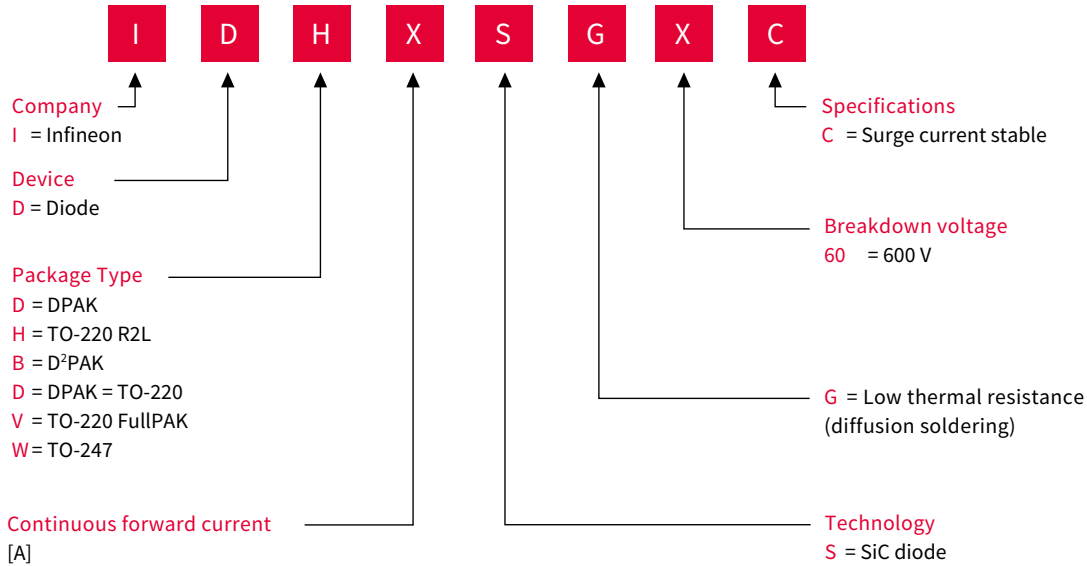

CoolSiC™ Schottky diodes G5 and G6

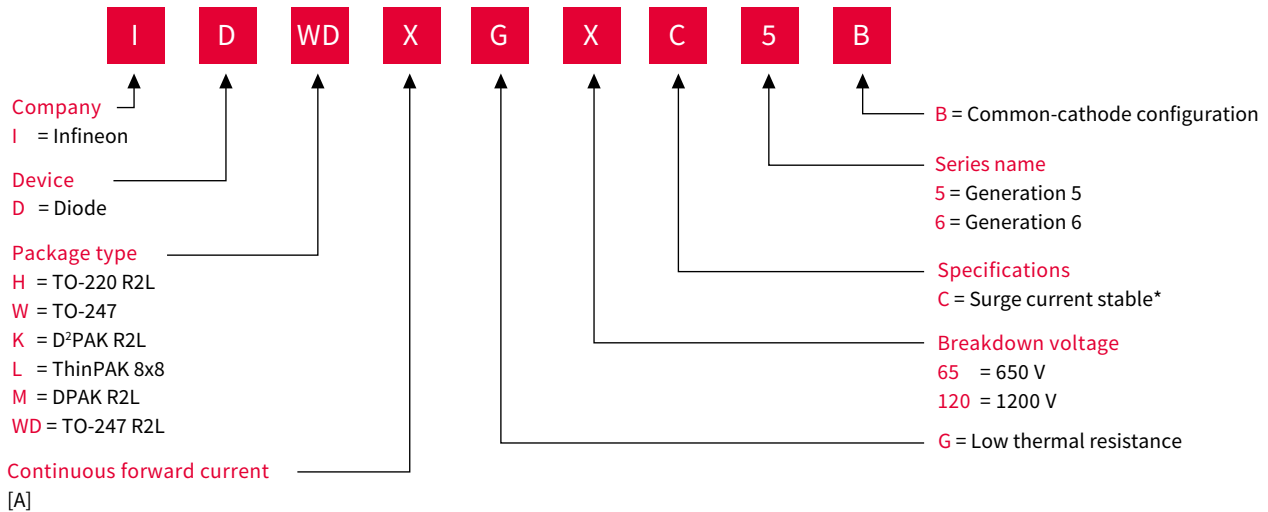

CoolSiC™ MOSFET

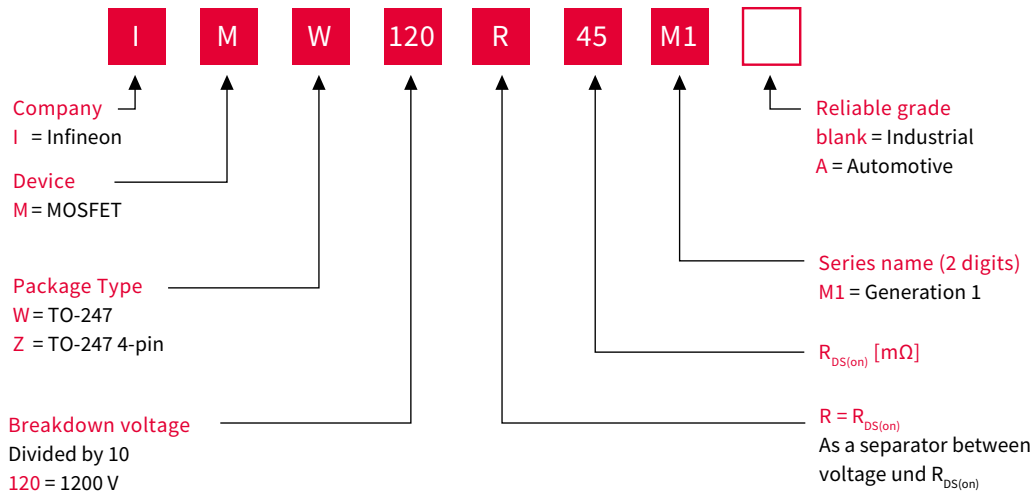

Silicon power diodes

Filling the gap between SiC diodes and emitter controlled diodes

The Rapid diode family complements Infineon's existing high power 600 V/650 V diode portfolio by filling the gap between SiC diodes and previously released emitter controlled diodes. They offer a perfect cost/performance balance and target high efficiency applications switching between 18 and 100 kHz. Rapid 1 and Rapid 2 diodes are optimized to have excellent compatibility with CoolMOS™ and high speed IGBTs (insulated gate bipolar transistor) such as the TRENCHSTOP™ 5 and HighSpeed 3.

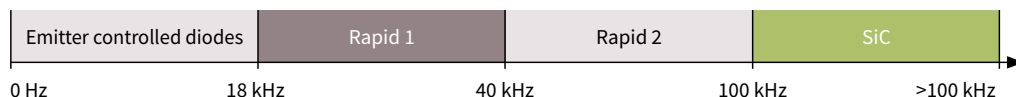

The Rapid 1 diode family

Rapid 1 is forward voltage drop (V_F) optimized to address low switching frequency applications between 18 kHz and 40 kHz, for example air conditioner and welder PFC stages.

- > 1.35 V temperature-stable forward voltage (V_F)
- > Lowest peak reverse recovery current (I_{rrm})
- > Reverse recovery time (t_{rr}) < 100 ns
- > High softness factor

The Rapid 2 diode family

Rapid 2 is $Q_{rr/trr}$ optimized hyperfast diode to address high speed switching applications between 40 kHz and 100 kHz, typically found in PFCs in high efficiency switch mode power supplies (SMPS) and welding machines.

- > Lowest reverse recovery charge (Q_{rr}): V_F ratio for best-in-class performance
- > Lowest peak reverse recovery current (I_{rrm})
- > Reverse recovery t_{rr} < 50 ns
- > High softness factor

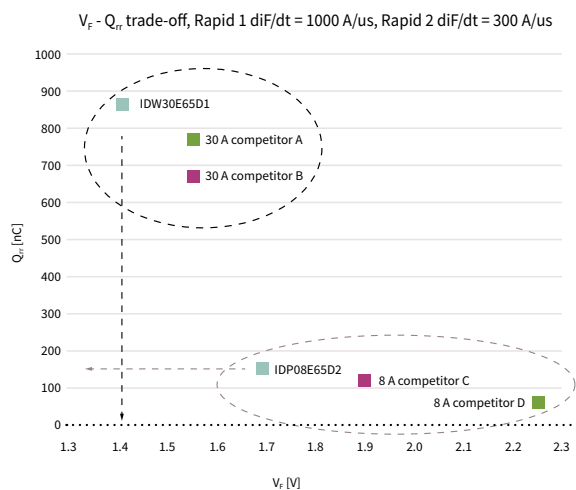

www.infineon.com/rapiddiodes

www.infineon.com/ultrasoftdiodes



Rapid 1 diodes

650 V product family



Continuous current I_c @ $T_c=100^\circ\text{C}$ [A]	TO-220 Halogen-Free	TO-220 FullPAK Halogen-Free	TO-220 common cathode Halogen-Free	TO-247 Halogen-Free	TO-247 common cathode Halogen-Free	TO-247 advanced isolation Halogen-Free
8	IDP08E65D1					
15	IDP15E65D1					
20		IDV20E65D1				
30	IDP30E65D1			IDW30E65D1	IDW30C65D1	
40				IDW40E65D1		IDFW40E65D1E
60					IDW60C65D1	IDFW60C65D1
75					IDW75D65D1	
80					IDW80C65D1	

Rapid 2 diodes





650 V product family



Continuous current I_c @ $T_c=100^\circ\text{C}$ [A]	TO-220 Halogen-Free	TO-220 FullPAK Halogen-Free	TO-220 common cathode Halogen-Free	TO-247 Halogen-Free	TO-247 common cathode Halogen-Free
8	IDP08E65D2	IDV08E65D2			
15	IDP15E65D2	IDV15E65D2		IDW15E65D2	
20	IDP20E65D2		IDP20C65D2		IDW20C65D2
30	IDP30E65D2	IDV30E65D2	IDP30C65D2		IDW30C65D2
40	IDP40E65D2			IDW40E65D2	
80					IDW80C65D2

Emitter controlled diodes
600 V and 1200 V product families



Continuous current I_c @ $T_c=100^\circ\text{C}$ [A]		TO-252 (DPAK)  Halogen-Free	TO-263 (D ² PAK)  Halogen-Free	TO-220 Real 2-pin  Halogen-Free	TO-247  Halogen-Free
600 V	6	IDD06E60			
	15		IDB15E60	IDP15E60	
	30		IDB30E60	IDP30E60	IDW30E60
	45			IDP45E60	
	50				IDW50E60
	75				IDW75E60
	100				IDW100E60
1200 V	12			IDP12E120	
	18			IDP18E120	
	30		IDB30E120	IDP30E120	

Nomenclature

Silicon power diodes

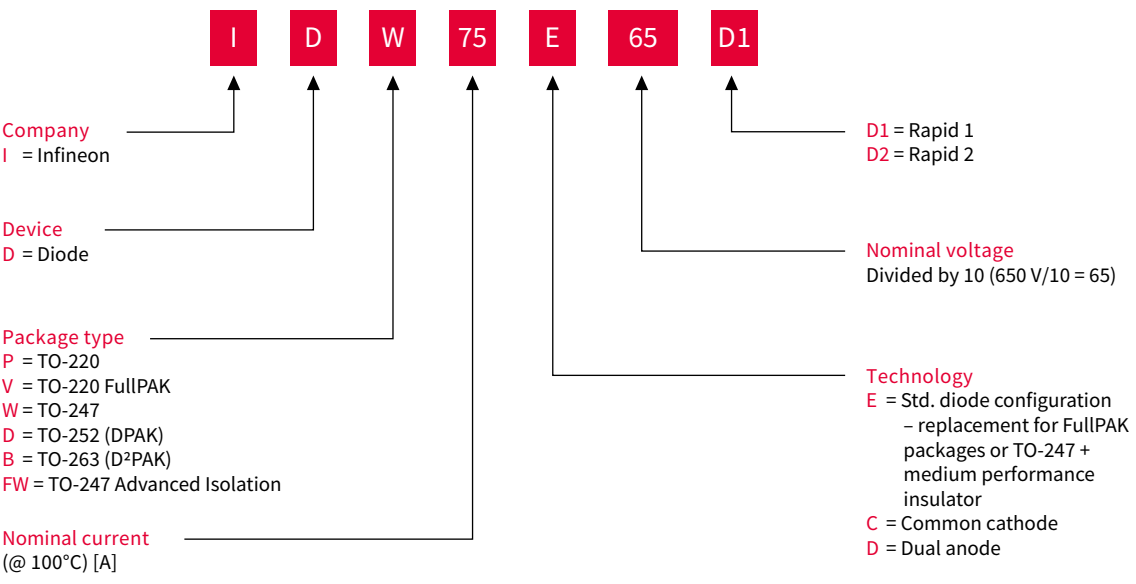



Infineon support for wide bandgap semiconductors

Useful links and helpful information

Further information, datasheets and documents

www.infineon.com/wbg

www.infineon.com/sic

www.infineon.com/rapiddiodes

www.infineon.com/ultrasoftdiodes

www.infineon.com/gan

www.infineon.com/gan-eicedriver

Videos

www.infineon.com/mediacenter

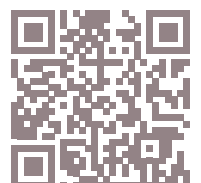

Discrete IGBTs

Market leadership through groundbreaking innovation and application focus

Resolute to achieve the highest standards in performance and quality, Infineon offers a comprehensive portfolio of application-specific discrete IGBTs.

Discrete IGBT overview

	P-SOT-223-4 SMD SMD, single transistor, small signal	TO-252 (DPAK)	TO-263 (D ² PAK)	TO-220	TO-220 FullPAK	TO-247	TO-247 4-pin	TO-247PLUS	TO-247PLUS 4-pin	TRENCHSTOP™ advanced isolation TO-247
Package options										
Voltage class	600 V, 650 V, 1100 V, 1200 V, 1350 V, 1600 V									600 V, 650 V
Configuration	DuoPack (with diode), single IGBTs									Duopack IGBTs (with diode) and diodes
Continuous collector current $T_c = 100^\circ\text{C}$	2-120 A									40-90 A

New best-in-class technologies and applications

Technology	Application
TRENCHSTOP™ 5 H5/F5 650 V	
TRENCHSTOP™ 5 L5 650 V	
Rapid diode 650 V	
RC-H5 650 V/1200 V/1350 V	
RC-E 1200 V	
WR5 650 V	
RC-drives RC-drives fast 600 V	
TRENCHSTOP™ 5 S5 650 V	
TRENCHSTOP™ IGBT6 650 V	
TRENCHSTOP™ IGBT6 1200 V	

www.infineon.com/igbt discret es

650 V TRENCHSTOP™ 5 IGBT

In terms of switching and conduction losses, there is no other IGBT on the market that can match the performance of the TRENCHSTOP™ 5. Wafer thickness has been reduced by more than 25 percent, which enables a dramatic improvement in both switching and conduction losses, while providing an increased breakthrough voltage of 650 V. Based on TRENCHSTOP™ 5 IGBT technology, Infineon has developed six different product families optimized for specific applications, allowing designers to optimize for high efficiency, system cost or reliability demands of the market. The quantum leap of efficiency improvement provided by the TRENCHSTOP™ 5 IGBT families opens up new opportunities for designers to explore.

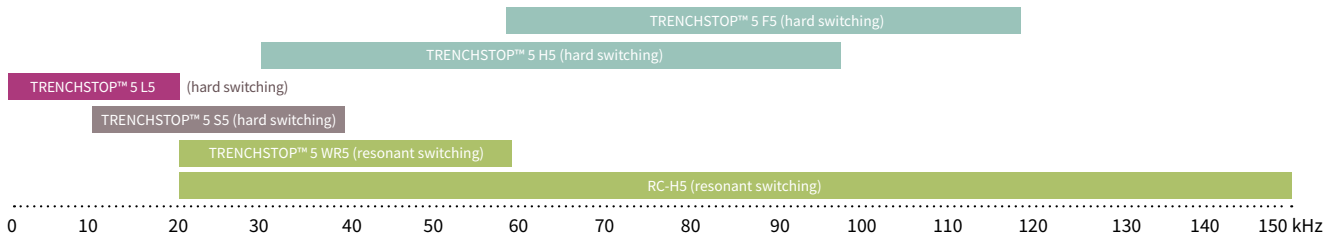

TRENCHSTOP™ 5 L5	Best-in-class IGBT low $V_{CE(sat)}$ IGBT $V_{CE(sat)}$ IGBT – 1.05 V Best trade-off $V_{CE(sat)}$, V_{ss} , E_{ts} for frequencies below 20 kHz	Solar, UPS, welding > Ultralow frequency converters > Three-level inverter type I NPC 1 and NPC 2 > Modified HERIC inverter > AC output (aluminum/magnesium welding)
TRENCHSTOP™ 5 S5	Best-in-class ease-of-use IGBT Elimination of: > Collector-emitter snubber capacitor and gate capacitor in low inductance designs (<100 nH) > Softer switching than TRENCHSTOP™ 5 H5	UPS, battery charger, solar, welding > Medium frequency converters > Multilevel inverter stages > Output stages > PFC
TRENCHSTOP™ 5 H5/F5	Best-in-class high frequency IGBT > Bridge to SJ MOSFET performance > Highest efficiency, especially under light load conditions	UPS, solar, welding > High frequency converters > Multilevel inverter stages > Output stages > PFC
TRENCHSTOP™ 5 R5	Price/performance optimized application specific IGBT	Induction cooking – RC-H5 Half-bridge topologies in induction cooking appliances and other resonant switching applications
TRENCHSTOP™ 5 WR5	Price optimized application specific IGBT for zero current switching (ZCS) > Optimized full rated hard switching turn-off typically found in welding > Excellent R_c controllability > Soft recovery plus low reverse recovery charge (Q_{rr}) for diode	Air conditioning, welding > Medium frequency converters > Zero-voltage switching > PFC

Highest power density in D²PAK footprint

Infineon's ultrathin TRENCHSTOP™ 5 IGBT technology allows higher power density in a smaller chip size. Infineon is the first on the market able to fit a 40 A 650 V IGBT with 40 A diode in D²PAK – 25 percent higher than any other competitors that are offering maximum 30 A DuoPack IGBT in D²PAK. Now it is possible to upgrade the available SMD designs for higher power output P_{out} .

Key features

- > The highest power density – 40 A IGBT co-packed with a 40 A diode in D²PAK
- > 25 percent higher current than any other competitor
- > Superior efficiency of leading TRENCHSTOP™ 5 technology

Key benefits

- > Higher power design with D²PAK package
- > Upgrade of the available designs for higher power output
- > Less paralleling for improved system reliability and less complexity
- > Smaller PCB, more compact system design, lighter

www.infineon.com/trenchstop5

1200 V IGBT families

The 1200 V TRENCHSTOP™ 2 IGBT is optimized for low conduction losses with the lowest saturation voltage $V_{CE(sat)}$ of 1.75 V. A soft fast recovery emitter controlled diode further minimizes the turn-on losses.

The 1200 V HighSpeed 3 discrete IGBTs provides the lowest losses and the highest reliability for switching above 20 kHz. Transition to fast switching high speed devices allows reduction in the size of the active components (25-70 kHz).

The new 1200 V IGBT generation, TRENCHSTOP™ IGBT6, is designed to meet requirements of high efficiency, lowest conduction and switching losses in hard switching and resonant topologies, operating at switching frequencies above 15 kHz. The IGBT6 devices can be used as direct replacement for the Highspeed3 H3 series, without any changes of the design. Such plug-and-play replacement of H3 with new S6 IGBT may benefit up to 0.2 percent efficiency improvement.

The RC-H5 family is the latest generation in the RC-H series of reverse conducting IGBT. With a monolithically integrated diode, they offer optimized performance for resonant switching applications such as induction cooking. R5 devices are also available in 1350 V blocking voltage.

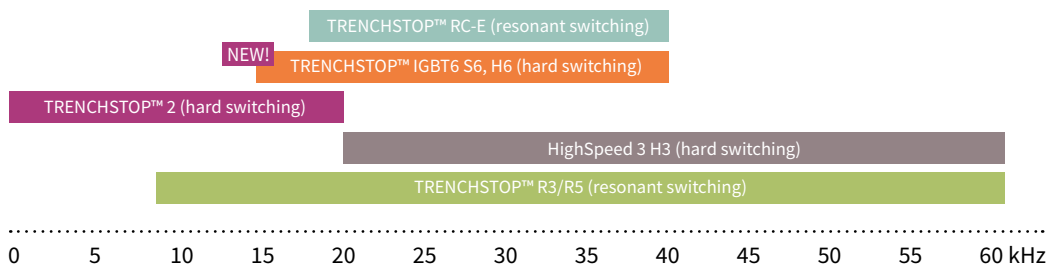

RC-H5	World-class TRENCHSTOP™ RC-H products High performance and low losses	Induction cooking Resonant switching Medium to high frequency converters
RC-E	New TRENCHSTOP™ RC-E Price versus performance leader	Induction cooking Resonant switching Low to medium power cookers
TRENCHSTOP™ 2	Best-in-class 1200 V IGBT <ul style="list-style-type: none"> > Outstanding efficiency > Lowest conduction and switching losses > Market proven and recognized quality leader 	Motor control, general purpose inverter, solar, UPS Low frequency converters
HighSpeed 3 H3	High speed/high power IGBT <ul style="list-style-type: none"> > First tailless/low loss IGBT on market > Market proven and recognized quality leader 	Solar, UPS, welding Medium frequency converters
NEW! TRENCHSTOP™ IGBT6	New low switching losses and high power IGBTs <ul style="list-style-type: none"> > Optimized for operation at 15 – 40 kHz > Best combination of low $V_{CE(sat)}$ of 1.85 V and low switching losses 	UPS, solar, welding Medium frequency converters

www.infineon.com/rch5

www.infineon.com/rc-e

www.infineon.com/igbt6-1200v

TRENCHSTOP™ IGBT6

650 V trench and field-stop IGBT for low power motor drives

Motor drives up to 1 kW are used in a wide variety of applications from home appliance fans and compressors to commercial sewing machines and pumps. The market for these products demands longer lifetimes, high reliability and high efficiency. Therefore, these compact motors require power electronics with the lowest losses and best thermal performance.

The TRENCHSTOP™ IGBT6 family of discrete devices has been designed to meet these specific requirements of motor drives. It has been optimized for the lowest switching losses, which is particularly important in systems with higher switching frequencies up to 30 kHz. Additionally, the IGBTs are co-packed with the soft, fast recovery Rapid 1 anti-parallel diodes for the lowest total losses.

With a higher blocking voltage at 650 V, and short circuit rating, TRENCHSTOP™ IGBT6 is a key contributor to robust motor designs.

The devices are offered in TO-220 FullPAK packages for the required isolation, as well as DPAK for a more compact surface mount solution.

- › Optimized for small drives requiring best-in-class efficiency
- › Up to 20 percent reduction in total losses
- › Lowest switching losses for better heat management and easier design-in

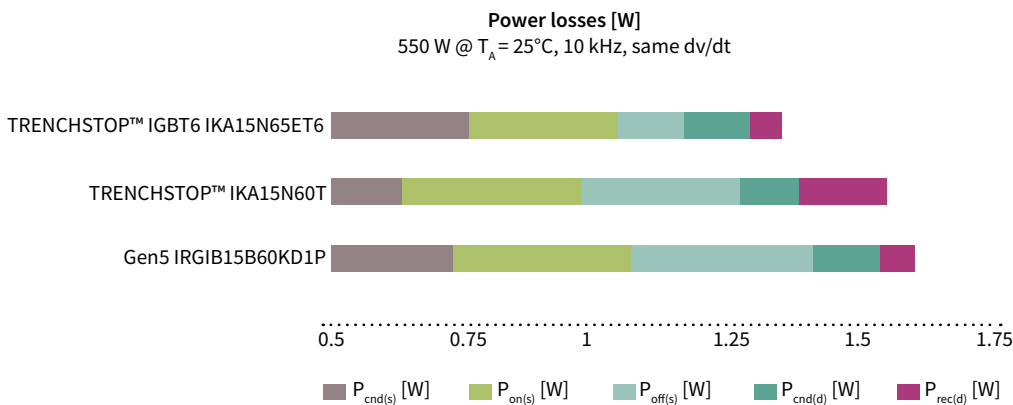

Key features

- › Lowest collector-emitter saturation voltage ($V_{CE(sat)}$) and forward voltage (V_F)
- › 650 V blocking voltage
- › 3 μsec short-circuit protection capability
- › Optimized for switching frequencies from 8–30 kHz

Key benefits

- › Good thermal performance, especially at higher frequencies
- › Low losses to meet energy efficiency requirements
- › Increased design margin and reliability
- › Leading price/performance

www.infineon.com/igbt6

TRENCHSTOP™ IGBT6

New generation 1200 V fast speed IGBT

The new 1200 V IGBT generation TRENCHSTOP™ IGBT6 is designed to meet requirements of high efficiency, lowest conduction and switching losses in hard switching and resonant topologies operating at switching frequencies above 15 kHz.

The TRENCHSTOP™ IGBT 6 is released in two product families – low conduction losses optimized S6 series and improved switching losses H6 series. The TRENCHSTOP™ IGBT6 S6 series features low conduction losses of 1.85 V collector-emitter saturation voltage $V_{CE(sat)}$ combined with low switching losses of the HighSpeed 3 H3 series. TRENCHSTOP™ IGBT6 H6 series is optimized for low switching losses, provides ~15 percent lower total switching losses when compared to predecessor generation H3.

Very soft, fast recovery anti-parallel emitter controlled diode is optimized for fast recovery while still maintaining a high level of softness complementing to an excellent EMI behaviour.

Positive temperature coefficient allows easy and reliable device paralleling. Very good R_g controllability allows adjustment of IGBT switching speed to the requirements of application.

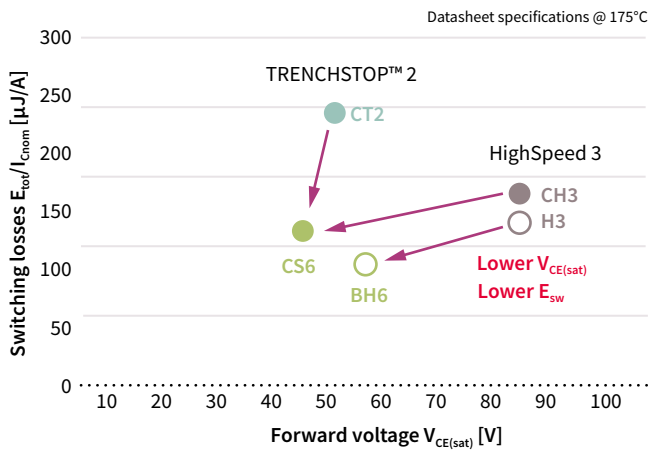

Key features

- > Easy, plug and play replacement of predecessor HighSpeed 3 H3 IGBT
- > 0.15 percent system efficiency improvement when changing from H3 to S6 in TO-247-3²⁾
- > 0.2 percent system efficiency improvement when changing from H3 to S6 in TO-247PLUS 4-pin²⁾

Key benefits

- > Best combination of switching and conduction losses for switching frequency 15–40 kHz
- > Low conduction losses with 1.85 V $V_{CE(sat)}$ for S6 series
- > High R_g controllability
- > Low EM
- > Full rated, robust freewheeling diode

www.infineon.com/igbt6-1200V

TRENCHSTOP™ advanced isolation

Fully isolated TO-247 package with industry leading IGBTs

TRENCHSTOP™ advanced isolation solution breaks the limits reached by traditional packaging and isolation techniques. This new isolated package enables the highest power density, the best performance and the lowest cooling effort thanks to an effective and reliable thermal path from the IGBT die to the heatsink.

In addition to providing 100 percent electrical isolation, TRENCHSTOP™ advanced isolation also eliminates the need for thermal grease or thermal interface sheets. The new package delivers at least 35 percent lower thermal resistivity, helping designers to increase power density, as well as lower system complexity and assembling costs.

This new package solution allows industrial and home appliance designs to fully utilize the high performance of TRENCHSTOP™ IGBTs without compromises for isolation and cooling.

Key features

- > 2500 V_{RMS} electrical isolation, 50/60 Hz, t = 1 min
- > 100 percent tested isolated mounting surface
- > Lowest R_{th(j-h)}
- > Low coupling capacitance, 38 pF
- > No need for isolation film or thermal interface material

Key benefits

- > Up to 35 percent reduction in assembly time reduces manufacturing cost
- > Increased power density
- > Improved reliability from higher yield and no isolation film misalignment
- > Less EMI filter design effort
- > Decreased heatsink size

Thermal resistivity of package and isolation types

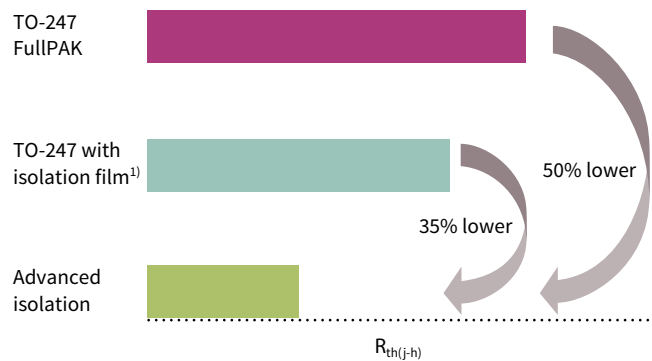

1) Isolation material: standard polyimide based reinforced carrier insulator film with 152 μm thickness, 1.3 W/mK thermal conductivity

TRENCHSTOP™ advanced isolation offers a broad portfolio for specific application needs

Technology	Version and package	Part number	Equivalent current rating @ 65°C [A]	R _{th(j-h)} [K/W]	V _{CEsat} [V] @ T _{vj} = 25°C
TRENCHSTOP™ HighSpeed 3	Price/performance advanced isolation TO-247 ¹⁾	IKFW40N60DH3E	44	1.35	2.30
		IKFW50N60DH3E	60	1.15	2.20
		IKFW60N60DH3E	74	1.06	2.20
	Best-in-class advanced isolation TO-247 ²⁾	IKFW50N60DH3	60	1.03	1.85
		IKFW60N60EH3	63	0.91	1.85
		IKFW90N60EH3	95	0.84	1.85
TRENCHSTOP™	Best-in-class advanced isolation TO-247	IKFW50N60ET	64	0.91	1.50
		IKFW75N60ET	95	0.84	1.50
Technology	Version and package	Part number	Equivalent current rating @ 65°C [A]	R _{th(j-h)} [K/W]	V _f [V]
Rapid 1 diode	Price/performance advanced isolation TO-247	IDFW40E65D1E	35	1.92	1.70
		IDFW60C65D1	2 x 30	1.37	1.45

1) Optimized to replace FullPAK packages or systems including TO-247 with medium performance insulator, standard polyimide based reinforced carrier insulator with 152 μm thickness, 0.9 W/mK thermal conductivity.

2) Optimized to replace systems using TO-247 with high performance insulator, standard polyimide based reinforced carrier insulator with 152 μm thickness, 1.3 W/mK thermal conductivity.

www.infineon.com/advanced-isolation

TRENCHSTOP™ 5 selection tree

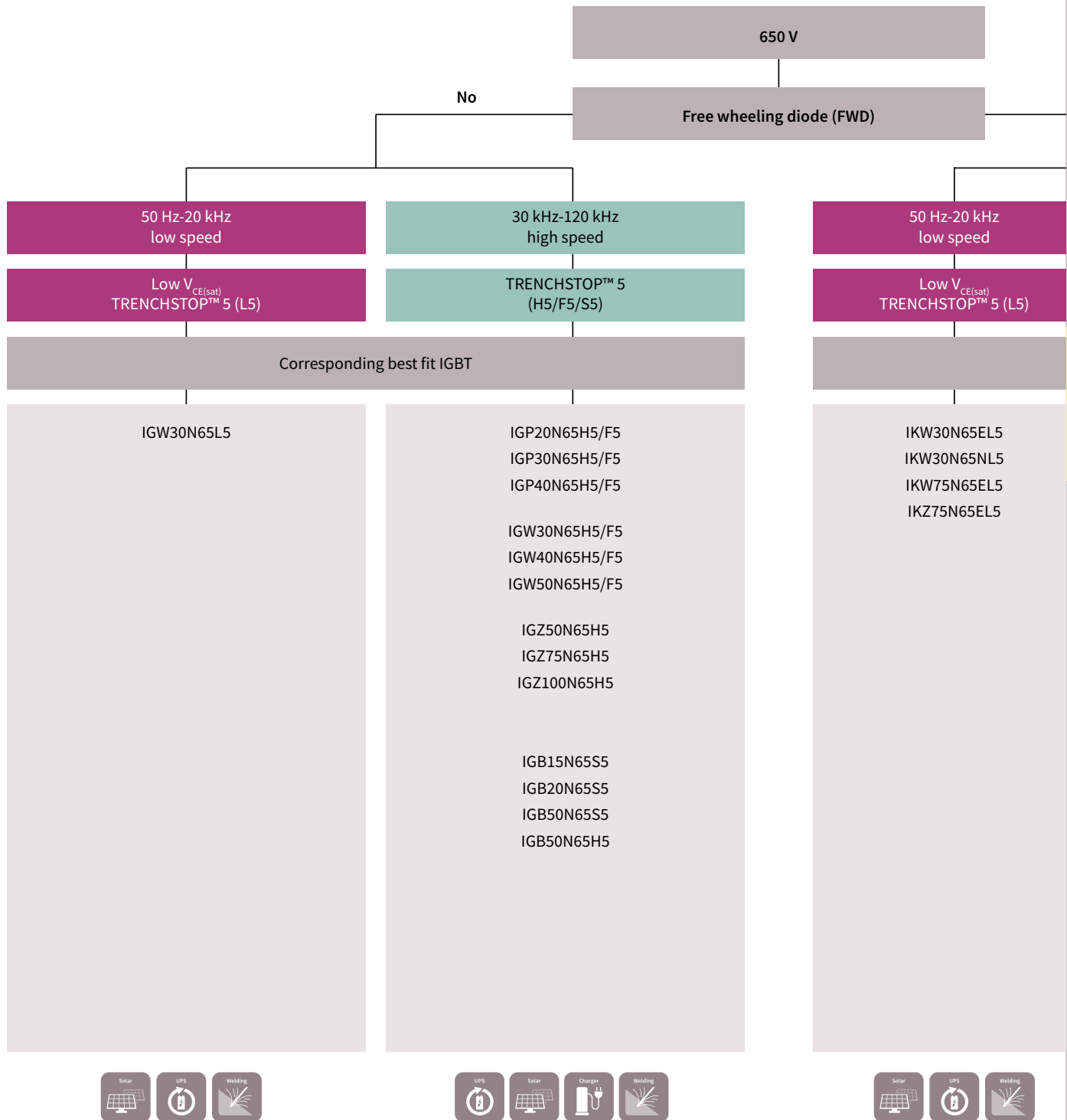

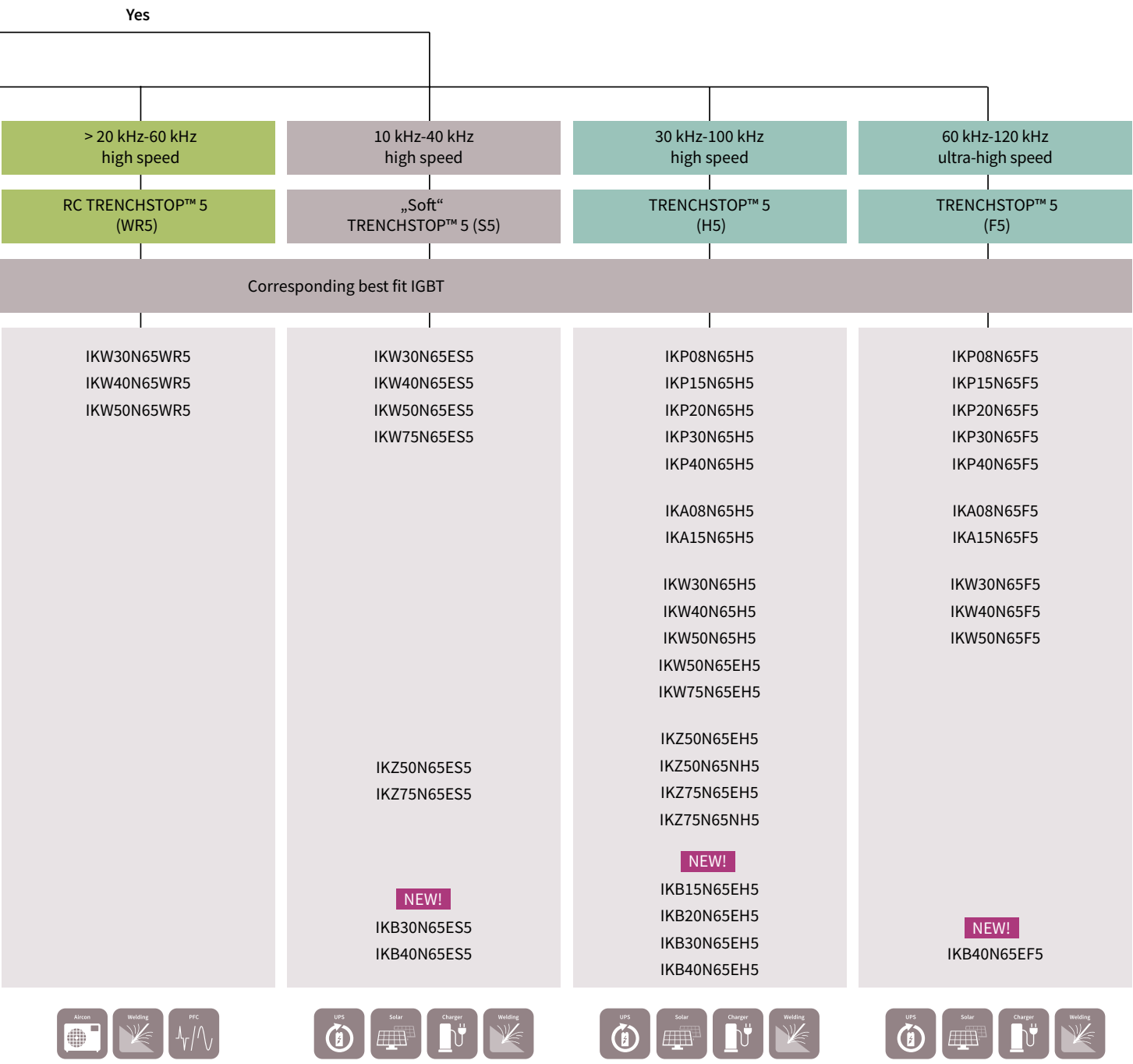

IGBT selection tree

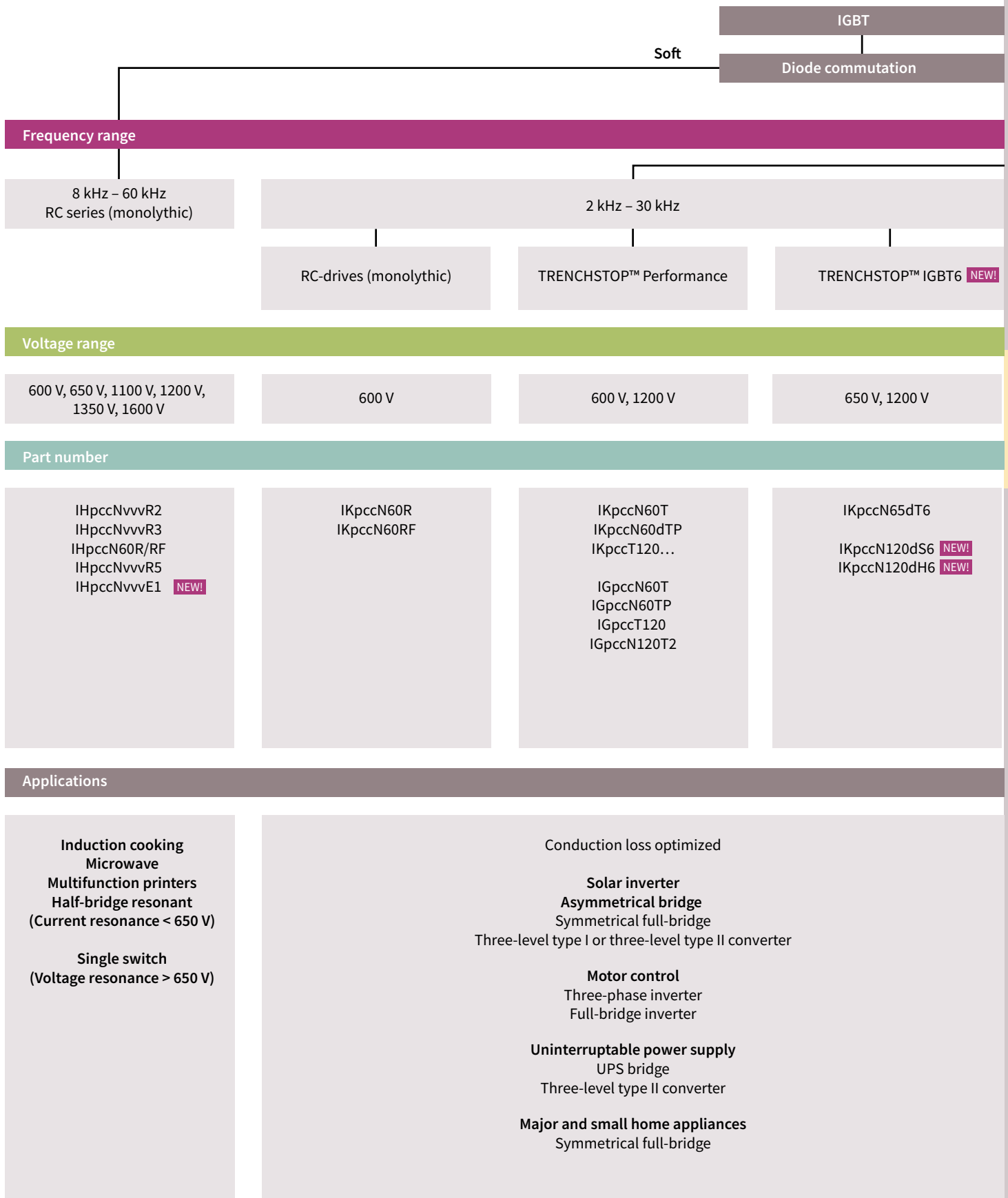

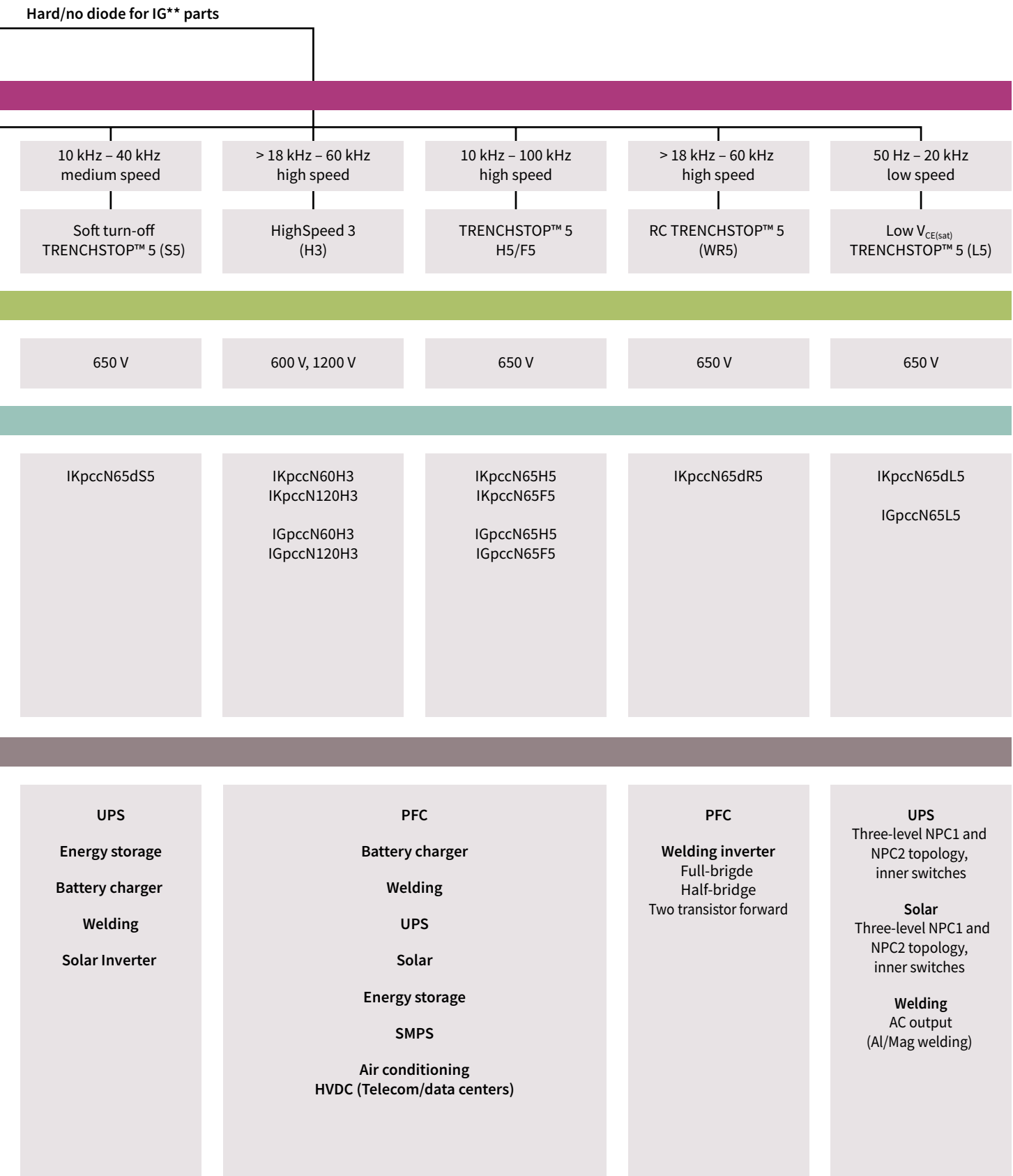



TRENCHSTOP™ and RC-drives

600 V product family



	Continuous collector current @ T _c =100°C [A]	TO-251 (IPAK) Halogen-Free	TO-252 (DPAK) Halogen-Free	TO-263 (D ² PAK) Halogen-Free	TO-220 Halogen-Free	TO-247 advanced isolation Halogen-Free	TO-220 FullPAK Halogen-Free	TO-247 Halogen-Free	TO-247PLUS/ Super 247 (TO247AA) Halogen-Free
Single IGBT	4	IGU04N60T							
	6		IGD06N60T		IGP06N60T				
	10			IGB10N60T	IGP10N60T				
	15			IGB15N60T	IGP15N60T				
	30			IGB30N60T				IGW30N60T IGW30N60TP	
	40							IGW40N60TP	
	50			IGB50N60T	IGP50N60T			IGW50N60T IGW50N60TP	
	75							IGW75N60T	
IGBT and diode	3		IKD03N60RF						
	4		IKD04N60RF IKD04N60R		IKP04N60T				
	6		IKD06N60RF IKD06N60R IKD06N65ET6	IKB06N60T	IKP06N60T		IKA06N60T		
	10		IKD10N60RF IKD10N60R	IKB10N60T	IKP10N60T		IKA10N60T		
	15		IKD15N60RF IKD15N60R	IKB15N60T	IKP15N60T		IKA15N60T		
	20			IKB20N60T	IKP20N60T			IKW20N60T	
	30							IKW30N60T IKW30N60DTP	
	40							IKW40N60DTP	
	50						IKFW50N60ET	IKW50N60T IKW50N60DTP	
	75						IKFW75N60ET	IKW75N60T	
	100								IKQ100N60T
	120								IKQ120N60T

www.infineon.com/600V-1200V-trenchstop



Applications
20-300 V MOSFETs
500-950 V MOSFETs
WBG semiconductors
Discrete IGBTs
Power ICS
Gate driver ICS
Motor control ICS
Microcontrollers
XENSIV™ sensors
Packages

TRENCHSTOP™ IGBT6

650 V product family



Continuous collector current @ T _c =100°C [A]	TO-252 (DPAK) Halogen-Free	TO-263 (D ² PAK) Halogen-Free	TO-220 Halogen-Free	TO-262 (I ² PAK) Halogen-Free	TO-220 FullPAK Halogen-Free
6	IKD06N65ET6				
8					
10					
15					

TRENCHSTOP™ IGBT6 NEW!

1200 V fast speed IGBT product family

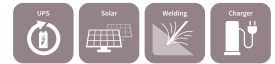

Continuous collector current @ T _c =100°C [A]	TO-263 (D ² PAK) Halogen-Free	TO-220 Halogen-Free	TO-262 (I ² PAK) Halogen-Free	TO-220 FullPAK Halogen-Free	TO-247	TO-247PLUS 3-pin Halogen-Free	TO-247PLUS 4-pin Halogen-Free
DuoPack	15						
	40				IKW15N120BH6		
	75				IKW40N120CS6		IKY40N120CS6

TRENCHSTOP™

1200 V product family



Continuous collector current @ T _c =100°C [A]	TO-252 (DPAK) Halogen-Free	TO-263 (D ² PAK) Halogen-Free	TO-220 Halogen-Free	TO-262 (I ² PAK) Halogen-Free	TO-220 FullPAK	TO-247 Halogen-Free		TO-247PLUS 3-pin Halogen-Free
	TRENCHSTOP™		TRENCHSTOP™ 2		TRENCHSTOP™ 2			
Single IGBT	8					IGW08T120		
	15					IGW15T120		
	25					IGW25T120		
	40					IGW40T120		
	60					IGW60T120		
DuoPack	8					IKW08T120		
	15					IKW15T120	IKW15N120T2	
	25					IKW25T120	IKW25N120T2	
	40					IKW40T120	IKW40N120T2	IKQ40N120CT2
	50							IKQ50N120CT2

www.infineon.com/igbt6

* Limited by maximum junction temperature. Applicable for TO-220 standard package.

Induction cooking series

650 V, 1100 V, 1200 V, 1350 V and 1600 V product families



Continuous collector current @ T _c =100°C [A]		TO-247				
		650 V	1100 V	1200 V	1350 V	1600 V
IGBT	15			IHW15N120E1 NEW!		
	20	IHW20N65R5		IHW20N120R5	IHW20N135R5	
	25			IHW25N120E1 NEW!		
	30	IHW30N65R5	IHW30N110R3	IHW30N120R5	IHW30N135R5	IHW30N160R2
	40	IHW40N65R5		IHW40N120R5	IHW40N135R5	
	50	IHW50N65R5				

HighSpeed 3

600 V product family



Continuous collector current @ T _c =100°C [A]		TO-251 (IPAK)	TO-252 (DPAK)	TO-263 (D ² PAK)	TO-220	TO-247 advanced isolation	TO-220 FullPAK	TO-247
			Halogen-Free	Halogen-Free	Halogen-Free	Halogen-Free	Halogen-Free	Halogen-Free
IGBT	20			IGB20N60H3	IGP20N60H3			IGW20N60H3
	30			IGB30N60H3	IGP30N60H3			IGW30N60H3
	40							IGW40N60H3
	50							IGW50N60H3
	60							IGW60N60H3
	75							IGW75N60H3
	100							IGW100N60H3
DuoPack	20			IKB20N60H3	IKP20N60H3			IKW20N60H3
	30							IKW30N60H3
	40					IKFW40N60DH3E		IKW40N60H3
	50					IKFW50N60DH3E IKFW50N60DH3		IKW50N60H3
	60					IKFW60N60DH3E IKFW60N60EH3		IKW60N60H3
	75							IKW75N60H3
	90					IKFW90N60EH3		

HighSpeed 3

1200 V product family



Continuous collector current @ T _c =100°C [A]		TO-263 (D ² PAK)	TO-220	TO-262 (I ² PAK)	TO-220 FullPAK	TO-247	TO-247PLUS 3-pin	TO-247PLUS 4-pin
		Halogen-Free	Halogen-Free	Halogen-Free	Halogen-Free	Halogen-Free	Halogen-Free	Halogen-Free
IGBT	15					IGW15N120H3		
	25					IGW25N120H3		
	40					IGW40N120H3		
DuoPack	15					IKW15N120H3		
	25					IKW25N120H3		
	40					IKW40N120H3	IKQ40N120CH3	IKY40N120CH3
	50						IKQ50N120CH3	IKY50N120CH3
	75					IKQ75N120CH3	IKY75N120CH3	

www.infineon.com/rch5

www.infineon.com/rc-e

www.infineon.com/advanced-isolation

TRENCHSTOP™ 5 F5, H5 and S5

650 V product family



	Continuous collector current @ T _c =100°C [A]	TO-251 (IPAK)	TO-252 (DPAK)	TO-263 (D ² PAK)	TO-220	TO-262 (I ² PAK)	TO-220 FullPAK	TO-247	TO-247 4-pin
			Halogen-Free	Halogen-Free	Halogen-Free	Halogen-Free	Halogen-Free	Halogen-Free	Halogen-Free
IGBT	20			IGB20N65S5	IGP20N65F5/H5				
	30			IGB30N65S5	IGP30N65F5/H5				
	40				IGP40N65F5/H5			IGW40N65F5/H5	
	50			IGB50N60H5 NEW!				IGW50N65F5/H5	IGZ50N65H5
				IGB50N60S5 NEW!					
								IGW75N65H5	IGZ75N65H5
DuoPack	100								IGZ100N65H5
	8				IKP08N65F5/H5		IKA08N65F5/H5		
	15			IKB15N65EH5 NEW!	IKP15N65F5/H5		IKA15N65F5/H5		
	20			IKB20N65EH5 NEW!	IKP20N65H5/F5				
	28				IKP28N65ES5 NEW!				
	30			IKB30N65EH5 NEW!	IKP30N65H5/F5			IKW30N65H5	
				IKB30N65ES5 NEW!					
	39				IKP39N65ES5 NEW!				
	40			IKB40N65ES5 NEW!	IKP40N65F5/H5			IKW40N65F5/H5	
				IKB40N65EH5 NEW!					
			IKB40N65EF5 NEW!						
50							IKW50N65F5/H5	IKZ50N65EH5	
							IKW50N65EH5	IKZ50N65NH5	
75							IKW75N65EH5	IKZ75N65NH5	
								IKZ75N65EH5	

TRENCHSTOP™ 5 L5 low V_{CE(sat)}

650 V product family



	Continuous collector current @ T _c =100°C [A]	TO-251 (IPAK)	TO-252 (DPAK)	TO-263 (D ² PAK)	TO-220	TO-262 (I ² PAK)	TO-220 FullPAK	TO-247	TO-247 4-pin
			Halogen-Free	Halogen-Free	Halogen-Free	Halogen-Free	Halogen-Free	Halogen-Free	Halogen-Free
IGBT	30							IGW30N65L5	
DuoPack	30							IKW30N65EL5 IKW30N65NL5	
	75							IKW75N65EL5	IKZ75N75EL5

TRENCHSTOP™ 5 WR5

650 V product family



	Continuous collector current @ T _c =100°C [A]	TO-251 (IPAK)	TO-252 (DPAK)	TO-263 (D ² PAK)	TO-220	TO-262 (I ² PAK)	TO-220 FullPAK	TO-247	TO-247 4-pin
			Halogen-Free	Halogen-Free	Halogen-Free	Halogen-Free	Halogen-Free	Halogen-Free	Halogen-Free
DuoPack	30							IKW30N65WR5	
	40							IKW40N65WR5	
	50							IKW50N65WR5	

TRENCHSTOP™ 5 S5

650 V product family



	Continuous collector current @ T _c =100°C [A]	TO-251	TO-252 (DPAK)	TO-263 (D ² PAK)	TO-220	TO-262 (I ² PAK)	TO-220 FullPAK	TO-247	TO-247 4-pin
			Halogen-Free	Halogen-Free	Halogen-Free	Halogen-Free	Halogen-Free	Halogen-Free	Halogen-Free
DuoPack	30							IKW30N65ES5	
	40							IKW40N65ES5	
	50							IKW50N65ES5	IKZ50N65ES5
	75							IKW75N65ES5	IKZ50N65ES5

Nomenclature

IGBT (after 03/2013)

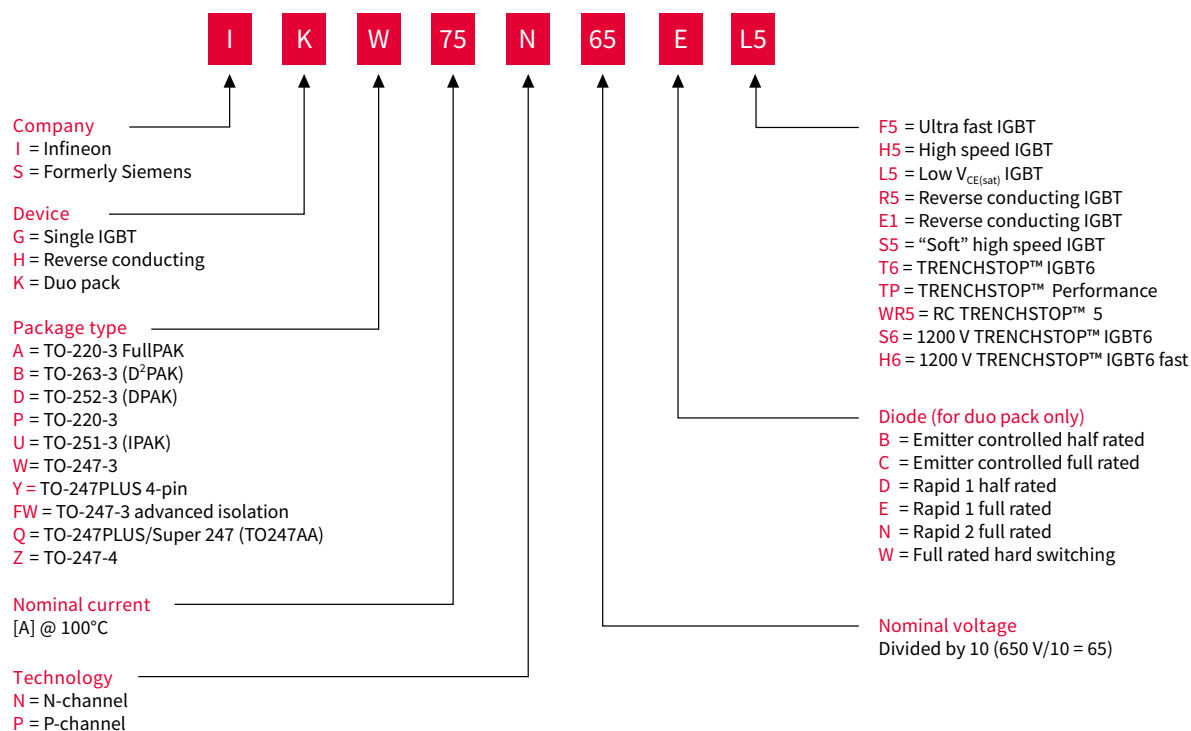

IGBT (before 03/2013)

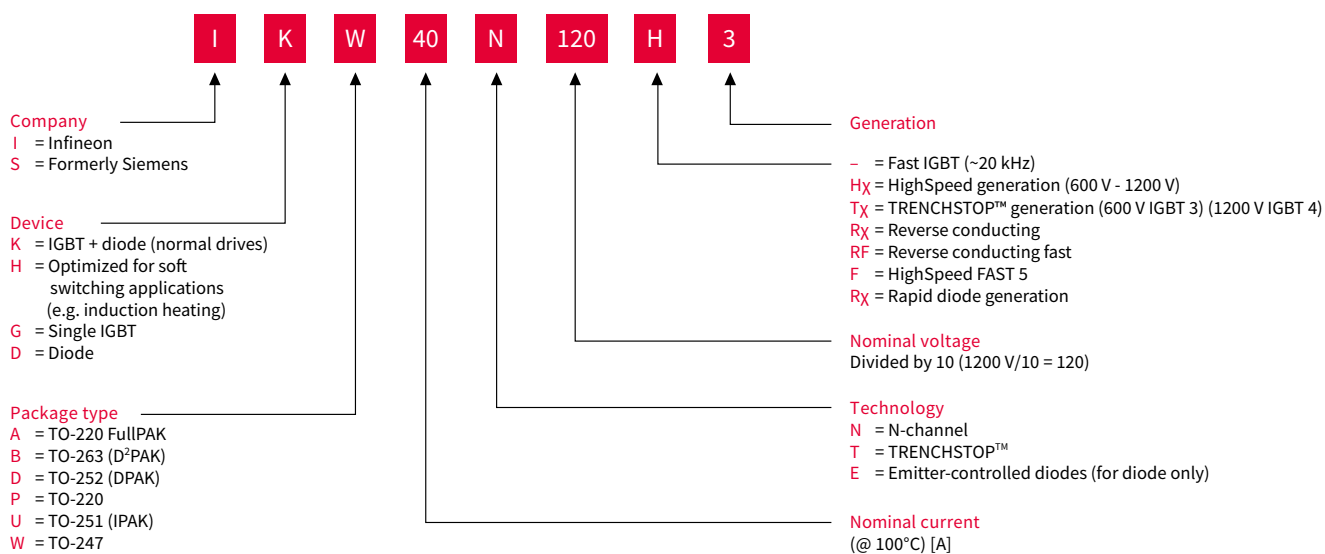



Infineon support for discrete IGBTs

Useful links and helpful information

Further information, datasheets and documents

www.infineon.com/igbt

www.infineon.com/igbt discret es

www.infineon.com/discrete-automotive-igbt

www.infineon.com/latest-discrete-packages

Evaluation boards and simulation models

www.infineon.com/eval-TO-247-4pin

www.infineon.com/igbt discrete-simulation models

Videos

www.infineon.com/mediacenter

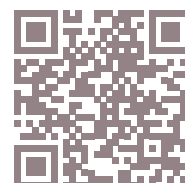

Power management ICs

Technology leadership in power supply

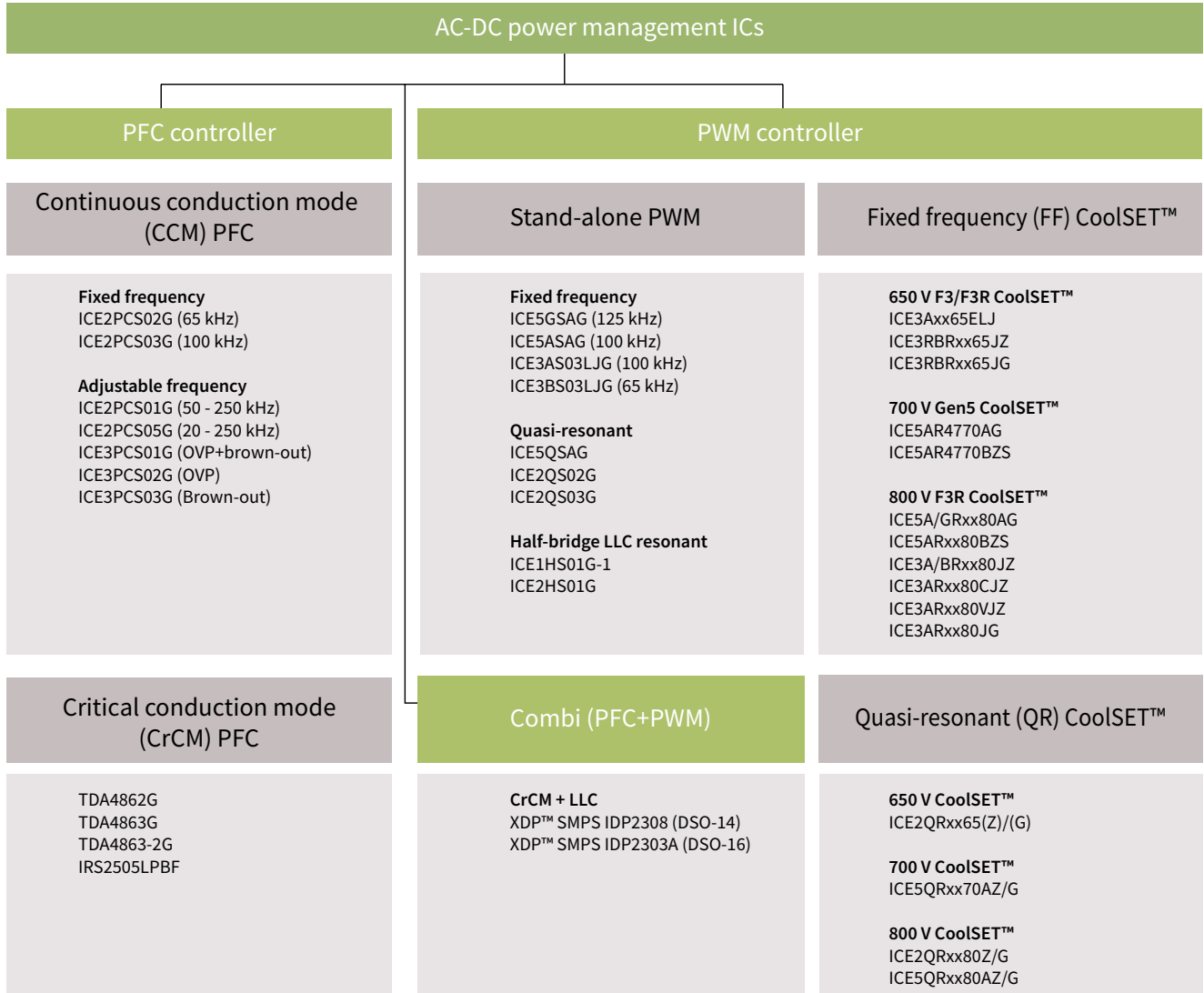

Power factor correction and combo controller

Critical conduction mode PFC ICs

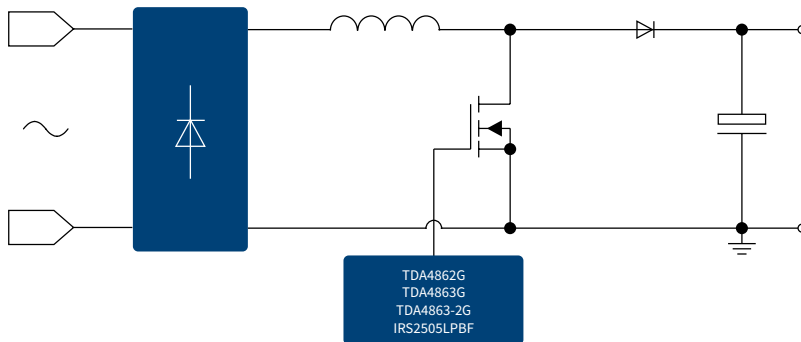

TDA4862G

Power factor controller (PFC) IC for high-power factor and active harmonic filter

- › IC for sinusoidal line current consumption
- › Power factor approaching 1
- › Controls boost converter as an active harmonics filter
- › Internal start-up with low current consumption
- › Zero current detector for discontinuous operation mode
- › High current totem pole gate driver
- › Trimmed $\pm 1.4\%$ internal reference
- › Undervoltage lockout with hysteresis
- › Very low start-up current consumption
- › Pin compatible with world standard
- › Output overvoltage protection
- › Current sense input with internal low pass filter
- › Totem pole output with active shutdown during UVLO
- › Junction temperature range -40°C to $+150^{\circ}\text{C}$
- › Available in DIP-8 and SO-8 packages

TDA4863G/TDA4863-2G

Power factor controller IC for high-power factor and low THD additional features to TDA4862

- › Reduced tolerance of signal levels
- › Improved light load behavior
- › Open loop protection
- › Current sense input with leading edge blanking LEB
- › Undervoltage protection
- › SO-8 package

IRS2505LPBF

- › Critical conduction mode PFC control
- › High power factor and ultralow THD
- › Wide load and line range
- › Regulated and programmable DC bus voltage
- › No secondary winding required
- › MOSFET cycle-by-cycle overcurrent protection
- › DC bus overvoltage protection
- › Low EMI gate drive
- › Ultralow start-up current
- › 20.8 V internal Zener clamp on V_{CC}
- › Excellent ESD and latch immunity
- › RoHS compliant
- › 5-pin SOT-23 package

Continuous conduction mode PFC ICs

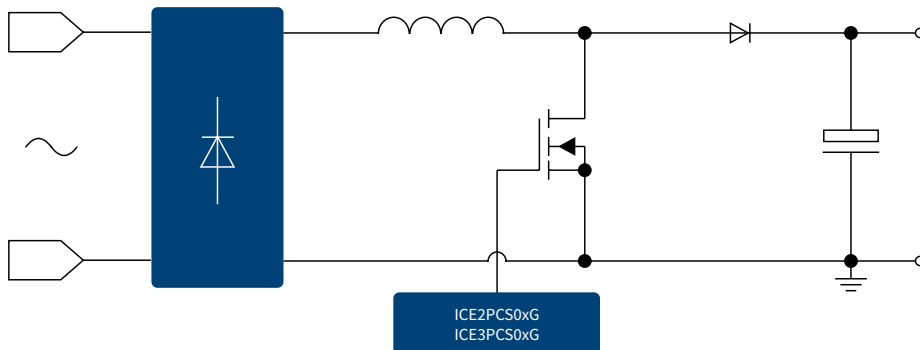
2nd generation continuous conduction mode PFC IC features

- › Fulfills class D requirements of IEC 61000-3-2
- › Lowest count of external components
- › Adjustable and fixed switching frequencies
- › Frequency range from 20 to 250 kHz
- › Versions with brown-out protection available
- › Wide input range supported
- › Enhanced dynamic response during load jumps
- › Cycle by cycle peak current limiting
- › Integrated protections OVP, OCP
- › DIP-8 and DSO-8
- › Lead-free, RoHS compliant

2nd generation continuous conduction mode PFC IC product portfolio

Product	Frequency – f_{sw}	Current drives	Package
ICE2PCS01G	50-250 kHz	2.0 A	DSO-8
ICE2PCS02G	65 kHz	2.0 A	
ICE2PCS03G	100 kHz	2.0 A	
ICE2PCS05G	20-250 kHz	2.0 A	

3rd generation continuous conduction mode PFC IC features

- › Fulfills class D requirements of IEC 61000-3-2
- › Integrated digital voltage loop compensation
- › Boost follower function
- › Bulk voltage monitoring signals, brown-out
- › Multi protections such as double OVP
- › Fast output dynamic response during load jump
- › External synchronization
- › Extra-low peak current limitation threshold
- › SO-8 and SO-14
- › Lead-free, RoHS compliant

3rd generation continuous conduction mode PFC IC product portfolio

Product	Frequency – f_{sw}	Current drives	Features	Package
ICE3PCS01G	Adjustable	0.75 A	OVP+brown-out	SO-14
ICE3PCS02G		0.75 A	OVP	SO-8
ICE3PCS03G		0.75 A	Brown-out	SO-8

PFC CCM IC by feature	ICE2PCS01G ICE2PCS05G	ICE2PCS02G ICE2PCS03G	ICE3PCS03G	ICE3PCS02G	ICE3PCS01G
Digital control voltage loop	-	-	✓	✓	✓
Variable frequency	✓	-	✓	✓	✓
Synchronous frequency	-	-	✓	✓	✓
Open loop protection	✓	✓	✓	✓	✓
Low peak current limit	-1 V	-1 V	-0.4 V	-0.4 V	-0.2 V
Brown-out protection	-	✓	✓	-	✓
Overvoltage protection	✓	✓	✓	✓	✓
Second overvoltage protection	-	-	-	✓	✓
PFC enable function	-	-	-	-	✓
Boost follower mode	-	-	-	-	✓
5 V regulator	-	-	-	-	✓

Resonant LLC half-bridge controller IC

LLC resonant (no SR)

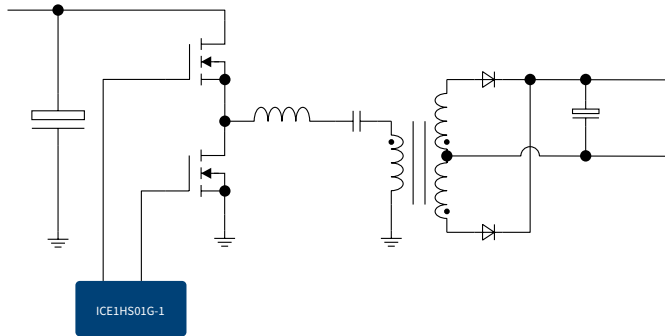

- > Novel and simple design (12 components + HB driver)
- > Minimum operating frequency is adjustable externally
- > Burst mode operation for output voltage regulation during no load and/or bus overvoltage
- > Multiple protections in case of fault
- > Input voltage sense for brown-out protection
- > Open loop/overload fault detection by FB pin with auto restart and adjustable blanking/restart time
- > Frequency shift for overcurrent protection
- > Lead-free, RoHS compliant package
- > DSO-8 package

Product	Frequency - f_{sw}	Dead time	Current drives	Package
ICE1HS01G-1	30 kHz-600 kHz	380 ns	1.5 A	DSO-8

Resonant LLC half-bridge controller IC with integrated synchronized rectifier control

LLC resonant + SR

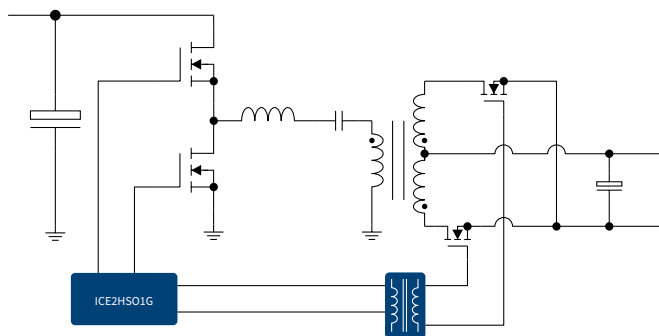

- > Novel LLC/SR operation mode and controlled by primary side controller
- > Multiple protections for SR operation
- > Tight tolerance control
- > Accurate setting of switching frequency and dead time
- > Simple system design
- > Optimized system efficiency
- > Multiple converter protections: OTP, OLP, OCP, latch-off enable
- > External disable for either SR switching or HB switching
- > Lead-free, RoHS compliant package
- > DSO-20 package

Product	Frequency - f_{sw}	Dead time	Current drives	Package
ICE2HS01G	30 kHz-1 MHz	100~1000 ns	0.3 A	DSO-20



LLC half-bridge controller IC	ICE1HS01G-1	ICE2HS01G
Package	DSO-8	DSO-20
Switching frequency range	up to 600 kHz	up to 1 MHz
LLC soft start	✓	✓
LLC burst mode	✓	✓
Adjustable minimum frequency	✓	✓
Overload/open loop protection	✓	✓
Mains undervoltage protection with hysteresis	✓	✓
Overcurrent protection	2-level	3-level
Drive signal for synchronous rectification	-	✓
Adjustable dead time	-	✓
External latch-off and OTP	-	✓
Target application	LCD-TV, audio, etc.	Server, PC, LCD-TV, etc.

Climate saver systems

Climate saver 80 PLUS® and 80 PLUS® Bronze

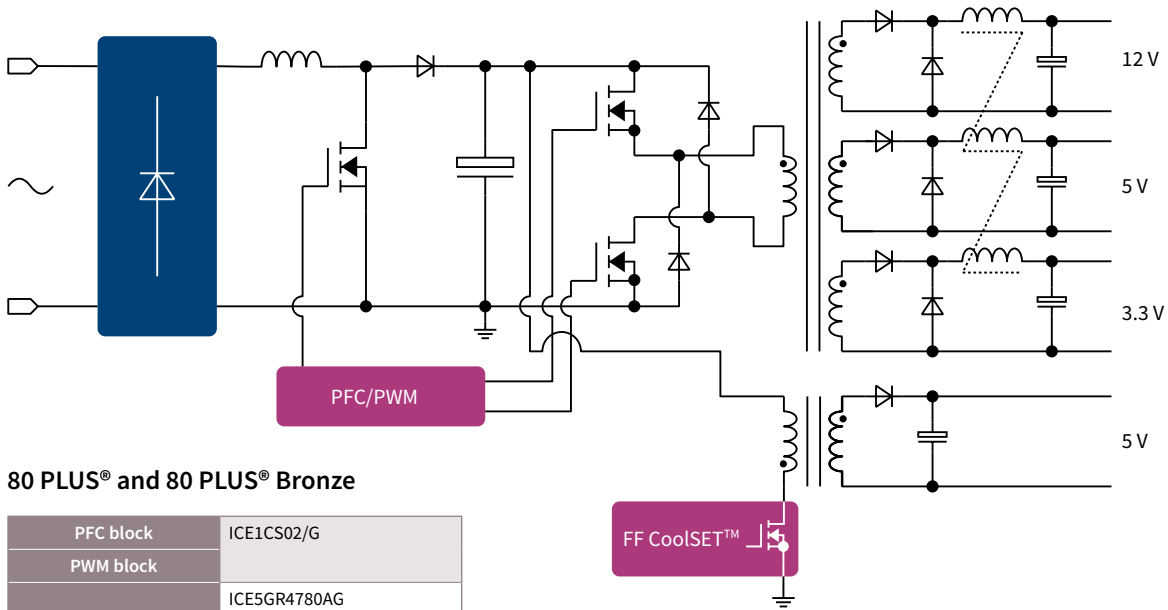

80 PLUS® and 80 PLUS® Bronze

PFC block	ICE1CS02/G
PWM block	
Standby block FF CoolSET™	ICE5GR4780AG
	ICE5GR2280AG
	ICE5GR1680AG
	ICE3AR1080JG
	ICE5AR0680AG

Climate saver 80 PLUS® Silver

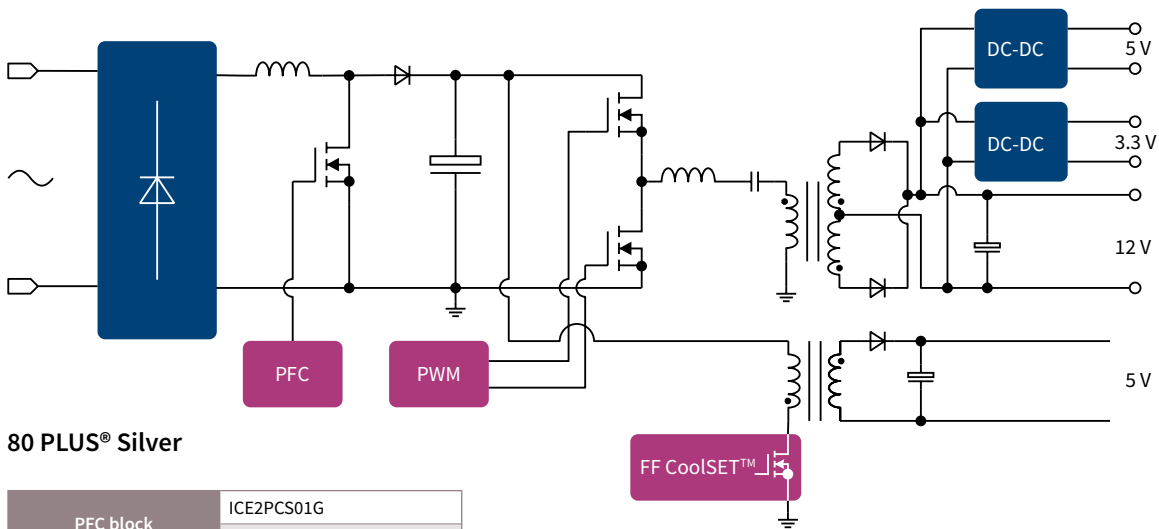

80 PLUS® Silver

PFC block	ICE2PCS01G
	ICE2PCS02G
PWM block	ICE1HS01G-1
Standby block FF CoolSET™	ICE5GR4780AG
	ICE5GR2280AG
	ICE5GR1680AG
	ICE3AR1080JG
	ICE5AR0680AG

Climate saver 80 PLUS® Gold

Climate saver 80 PLUS® Platinum

Certification for Infineon's PC power reference design

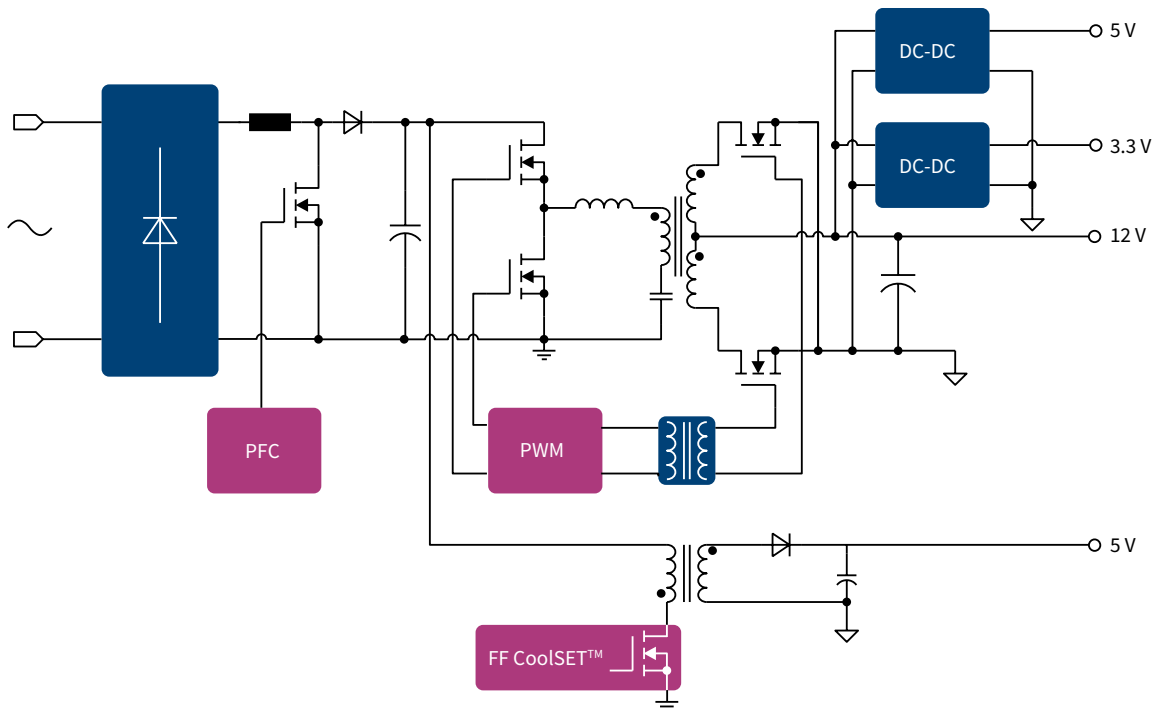

80 PLUS® Gold

PFC block	ICE3PCS01G
	ICE3PCS02G
	ICE3PCS03G
PWM block	ICE2HS01G
Standby block FF CoolSET™	ICE5GR4780AG
	ICE5GR2280AG
	ICE5GR1680AG
	ICE3AR1080JG
	ICE5AR0680AG

80 PLUS® Platinum

Certification for Infineon's PC power reference design

PFC block	ICE3PCS01G
	ICE3PCS02G
	ICE3PCS03G
PWM block	ICE2HS01G
Standby block QR CoolSET™	ICE5QR4780AZ
	ICE2QR4780G
	ICE5QR2280AZ
	ICE2QR2280G-1
	ICE5QR1680AG
	ICE2QR1080G
	ICE5QR0680AG

www.infineon.com/pcpower
www.infineon.com/acdc
www.infineon.com/coolset

Isolated AC-DC

5th generation quasi-resonant PWM IC and CoolSET™ features

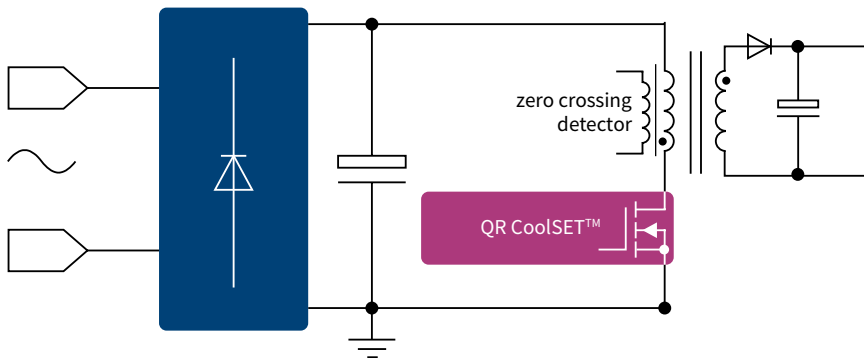

- > Integrated CoolMOS™ in both 700 V and 800 V MOSFET with cascode configuration
- > Digital frequency reduction with reducing load
- > Novel quasi-resonant to minimize the spread of switching frequency between low and high line AC input
- > Selectable active burst mode entry/exit profile
- > Auto restart mode for line overvoltage protection
- > Auto restart mode for brown-out protection
- > Auto restart mode for V_{CC} under-/overvoltage protection
- > Auto restart mode for open-loop and output overload protection
- > Auto restart mode for overtemperature protection with hysteresis
- > Auto restart mode for output overvoltage
- > Auto restart mode for CS pin short-to-ground protection
- > Limited charging current during V_{CC} pin short-to-ground protection
- > Peak power limitation with input voltage compensation
- > Minimum switching frequency limitation (no audible noise on power units on/off)
- > DSO package (controller) and DIP-7/DSO-12 (CoolSET™)



5th generation quasi-resonant CoolSET™

Output power ¹⁾ 85 V _{AC} ~300 V _{AC} T _s =50°C		15 W	22 W	27 W	32 W	41 W~42 W
R _{DS(on)} max		5.18 Ω	2.35 Ω	1.75 Ω	1.25 Ω	0.80 Ω
700 V	DIP-7	ICE5QR4770AZ	ICE5QR2270AZ		ICE5QR1070AZ	
	DSO-12	ICE5QR4770AG				
800 V	DIP-7	ICE5QR4780AZ	ICE5QR2280AZ			ICE5QR0680AZ
	DSO-12			ICE5QR1680AG		ICE5QR0680AG

2nd generation quasi-resonant CoolSET™

Output power ¹⁾ 85 V _{AC} ~300 V _{AC} T _s =50°C		14 W~15 W	20 W~21 W	23 W~26 W	31 W	38 W~42 W
R _{DS(on)} max		5.44 Ω ~ 5.18 Ω	2.62 Ω	1.96 Ω	1.11 Ω	0.75 Ω~0.71 Ω
650 V	DIP-7	ICE2QR4765Z		ICE2QR1765Z		ICE2QR0665Z
	DIP-8	ICE2QR4765		ICE2QR1765		ICE2QR0665
	DSO-12	ICE2QR4765G		ICE2QR1765G		ICE2QR0665G
800 V	DIP-7		ICE2QR2280Z			ICE2QR0680Z
	DSO-12	ICE2QR4780G	ICE2QR2280G ICE2QR2280G-1		ICE2QR1080G	

www.infineon.com/coolset

1) Calculated maximum output power in an open frame design at T_s=50°C, T_j=125°C and without copper area as heat sink

5th generation fixed frequency PWM IC and CoolSET™ features

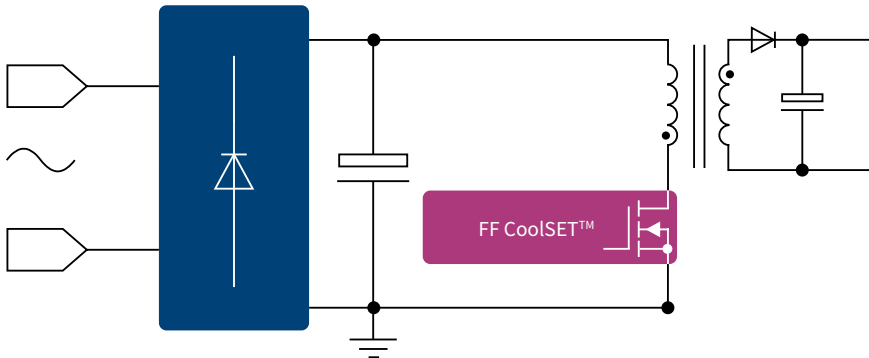

- > Integrated CoolMOS™ in both 700 V and 800 V MOSFET
- > Cascode configuration for brown-in protection, fast and robust start-up
- > Available in both 100 kHz and 125 kHz fixed switching frequency
- > Frequency reduction in tandem with load reduction to increase efficiency
- > Selectable active burst mode entry/exit profile to optimize standby power and ability to disable
- > Support CCM flyback operation with in-built slope compensation
- > Integrated error amplifier for direct feedback (e.g. non-isolated flyback)
- > Adjustable line input overvoltage protection (only ICE5xRxxxxAG)
- > V_{CC} and CS pin short-to-ground protection
- > Auto restart protection mode to minimize interruption to operation
- > DSO-8 package (standalone controller), DIP-7 and DSO-12 package for CoolSET™



5th generation fixed frequency CoolSET™

Output power ¹⁾ 85 V _{AC} ~300 V _{AC} T _s =50°C		15 W	23 W	27 W	40 W
R _{DS(on)} max		5.18 Ω	2.35 Ω	1.75 Ω	0.80 Ω
700 V	DIP-7	ICE5AR4770BZS			
	DSO-12	ICE5AR4770AG			
800 V	DIP-7	ICE5AR4780BZS			ICE5AR0680BZS
	DSO-12	ICE5GR4780AG	ICE5GR2280AG	ICE5GR1680AG	ICE5AR0680AG

3rd generation fixed frequency CoolSET™

Output power ¹⁾ 85 V _{AC} ~300 V _{AC} T _s =50°C		10~15 W	19~21 W	23~26 W	30~34 W	37~41 W
R _{DS(on)} max		11.1~5.44 Ω	3.42~2.62 Ω	1.96~1.71 Ω	1.11~1.05 Ω	0.75~0.71 Ω
650 V	DIP-7	ICE3RBR4765JZ		ICE3RBR1765JZ		ICE3RBR0665JZ
	DIP-8	ICE3BR4765J	ICE3A1065ELJ	ICE3BR1765J	ICE3A2065ELJ	ICE3BR0665J
	DSO-12	ICE3RBR4765JG		ICE3RBR1765JG		ICE3RBR0665JG
800 V	DIP-7	ICE3AR4780JZ	ICE3AR2280JZ	ICE3AR1580VJZ	ICE3AR1080VJZ	ICE3AR0680JZ
		ICE3AR4780VJZ	ICE3BR2280JZ			ICE3BR0680JZ
		ICE3AR4780CJZ	ICE3AR2280VJZ			ICE3AR0680VJZ
		ICE3AR10080CJZ	ICE3AR2280CJZ			
	DSO-12	ICE3AR4780JG	ICE3AR2280JG		ICE3AR1080JG	

www.infineon.com/coolset

1) Calculated DCM maximum output power in an open-frame design based on T_s=50° C and T_j=125° C without copper area as heatsink

Fixed frequency PWM IC

FF PWM IC	5 th generation		3 rd generation	
	ICE5ASAG	ICE5GSAG	ICE3AS03LJG	ICE3BS03LJG
Package	DSO-8		DSO-8	
Switching frequency	100 kHz	125 kHz	100 kHz	65 kHz
Operating temperature	-40°C~129°C		-25°C~130°C	
Start-up cell	Cascode		✓	
V _{cc} on/off threshold	16 V/10 V		18 V/10.5 V	
Soft start time	12 ms		10 ms	20 ms
Frequency jittering	✓		✓	
Modulated gate drive	✓		✓	
Active burst mode	✓ (3 level selectable)		✓	
Slope compensation for CCM	✓		-	
Frequency reduction	✓		-	
Integrated error amplifier for direct feedback	✓		-	
Adjustable line input overvoltage protection	✓ with auto restart		-	
Adjustable brown-in protection	✓ with auto restart		-	
CS pin short-to-ground protection	✓ with auto restart		-	
V _{cc} pin short-to-ground protection	✓ (no start-up)		-	
V _{cc} undervoltage protection	✓ with auto restart		✓ with auto restart	
V _{cc} overvoltage protection	✓ with auto restart		✓ with latch-up	
Overload /open loop protection	✓ with auto restart		✓ with auto restart	
Overtemperature protection	✓ with auto restart and hysteresis		✓ with latch-up	
External blanking time extension	-		✓ with auto restart	
External protection enable pin	-		✓ with latch-up	

Quasi-resonant PWM IC

Feature	ICE2QSAG	ICE2QS02G	ICE2QS03G
Package	DSO-8	DSO-8	DSO-8
Switching scheme	Novel QR with 10 zero crossing counters	QR with 7 zero crossing counters	QR with 7 zero crossing counters
Operating temperature	-40°C~129°C	-25°C~130°C	-25°C~130°C
Startup cell	Cascode	-	✓
V _{cc} on/off	16 V/10 V	12 V/11 V	18 V/10.5 V
Power saving during standby	✓ active burst mode in QR switching 2-level selectable burst mode entry/exit level	-	✓ active burst mode 52 kHz
Digital frequency reduction for high average efficiency	✓	✓	✓
OLP blanking time	Fixed	Adjustable	Fixed
Auto restart timer	Through V _{cc} charging/discharging	Setting with external components	Through V _{cc} charging/discharging
Maximum input power limitation	V _{in} pin voltage dependent	Adjustable through ZC resistor	Adjustable through ZC resistor
V _{cc} undervoltage protection	✓ with auto restart	✓ with latch	✓ with auto restart
Adjustable output overvoltage protection	✓ with auto restart	✓ with latch	✓ with latch
Adjustable line input overvoltage protection	✓	-	-
Brown-out feature	✓	✓	-
V _{cc} and CS pin short to ground protection	✓	-	-
Target application	Home appliances, set-top-box, AUX SMPS	AUX power supply to V _{cc} eg. LCD TV multi/main, audio main, PDP TV multi/address	Self-power supply to V _{cc} eg. smart meter, industrial applications



Quasi-resonant CoolSET™

	2 nd generation ICE2QRxxxxZ/G	2 nd generation ICE2QRxx80G-1	5 th generation ICE5QRxxxxAZ/G
Switching scheme	QR with 7 zero crossing counters		Novel QR with 10 zero crossing counters
Integrated MOSFET	650 V and 800 V	800 V	700 V and 800 V
High voltage start-up cell	✓		Cascode
Power saving during standby	Active burst mode f_{sw} @ 52 kHz		2 level selectable active burst mode quasi-resonant
V_{cc} on/off threshold (typ.)	18 V/10.5 V	18 V/9.85 V	16 V/10 V
Adjustable output overvoltage protection	✓ with latch		✓ with auto restart
V_{cc} over/undervoltage protection	✓ with auto restart		✓ with auto restart
Overload/open loop protection	✓ with auto restart		✓ with auto restart
Overtemperature protection	✓ with auto restart		✓ (Auto restart with hysteresis)
Adjustable line input overvoltage protection	-		✓ with auto restart
Brown-out	-		✓ with auto restart
CS pin short to ground	-		✓ with auto restart
V_{cc} pin short to ground	-		✓ (No start-up)
Package	DIP-7 DIP-8 DSO-12	DIP-7 DSO-12	DIP-7 DSO-12

www.infineon.com/coolset



Fixed frequency CoolSET™

	700 V CoolSET™		650 V CoolSET™	
	Gen5 ICE5ARxx70AG(BZS)	Gen3 ICE3Axx65ELJ	Gen3R ICE3BRxx65J	Gen3R ICE3RBRxx65JZ(G)
Package	DIP-7, DSO-12	DIP-8		DIP-7, DSO-12
Output power range	15 W	19 W~34 W	15 W~41 W	14 W~39 W
Operating temperature range	-40°C~129°C	-25°C~130°C		-40°C~130°C
Switching frequency	100 kHz	100 kHz	65 kHz	65 kHz
Frequency reduction	✓		-	
Integrated error amplifier	✓		-	
Slope compensation for CCM mode	✓		-	
V _{cc} on/off threshold	16 V/10 V		18 V/10.5 V	
Soft start time	12 ms		20 ms	
Active burst mode selection	3 level		1 level	
CS pin short-to-ground protection	Auto restart		-	
V _{cc} pin short-to-ground protection	No start-up		-	
V _{cc} overvoltage protection	Auto restart	Latch		Auto restart
Overtemperature protection	Auto restart with hysteresis	Latch		Auto restart
External protection enable pin	-	Latch		Auto restart
Adjustable brown-in/-out protection	Brown-in only		-	
Adjustable line input overvoltage protection	Only ICE5ARxx70AG		-	
Fast AC reset			-	
Product available	ICE5AR4770AG ICE5AR4770BZS	ICE3A1065ELJ ICE3A2065ELJ	ICE3BR4765J ICE3BR1765J ICE3BR0665J	ICE3RBR4765JZ ICE3RBR1765JZ ICE3RBR0665JZ ICE3RBR4765JG ICE3RBR1765JG ICE3RBR0665JG

www.infineon.com/coolset

1) Calculated 85 V_{ac}~300 V_{ac} DCM maximum output power in an open-frame design based on T_c=50°C and T_j=125°C without copper area as heatsink



800 V CoolSET™

Gen3R ICE3A(B)Rxx80JZ	Gen3R ICE3ARxx80CJZ	Gen3R ICE3ARxx80JG	Gen3R ICE3ARxx80VJZ	Gen5 ICE5ARxx80AG(BZS)	Gen5 ICE5GRxx80AG
DIP-7		DSO-12	DIP-7	DIP-7, DSO-12	DSO-12
10 W~40 W	11 W~23 W	14 W~30 W	15 W~39 W	15 W~40 W	15 W~27 W
-25°C~130°C		-40°C~130°C		-40°C~129°C	
100 kHz/65 kHz	100 kHz	100 kHz		100 kHz	125 kHz
	-			✓	
	-			✓	
-	✓			✓	
17 V/10.5 V				16 V/10 V	
10 ms				12 ms	
4 level	3 level	4 level		3 level	
	-			Auto restart	
	-			No start-up	
Auto restart					
Auto restart with hysteresis					
Auto restart	Latch	Auto restart	-		
Auto restart			-	Brown-in only	
	-	Auto restart		Only ICE5ARxx80AG	Auto restart
-	✓	-			
ICE3AR10080JZ ICE3AR4780JZ ICE3AR2280JZ ICE3AR0680JZ ICE3BR2280JZ ICE3BR0680JZ	ICE3AR10080CJZ ICE3AR4780CJZ ICE3AR2280CJZ	ICE3AR4780JG ICE3AR2280JG ICE3AR1080JG	ICE3AR4780VJZ ICE3AR2280VJZ ICE3AR1580VJZ ICE3AR1080VJZ ICE3AR0680VJZ	ICE5AR0680AG ICE5AR4780BZS ICE5AR0680BZS	ICE5GR4780AG ICE5GR2280AG ICE5GR1680AG

XDP™ SMPS

IDP2308 and IDP2303A – digital multi-mode PFC+LLC combo controller

The IDP2303 and IDP2303A are high performance digital combo controllers with integrated drivers and 600 V depletion cell designed for boost PFC and half-bridge LLC targeting switched mode power supplies (SMPS) from 75 W to 300 W.

- > Support non-AUX operation with the lowest standby performance and start-up cell
- > Support multi-mode PFC operation for optimized efficiency curve
- > Configurable frequency setting for LLC soft-start and normal operation
- > Synchronous PFC and LLC burst mode control with soft-start to prevent acoustic noise
- > Excellent dynamic response by adaptive LLC burst mode
- > Configurable and comprehensive protections for PFC/LLC/IC temp
- > IEC62368-1 certified active X-cap discharge function
- > Flexible IC parameter setting with digital UART interface supports PSU platform approach

Key benefits

- > Low BOM count due to high integration of digital control
- > No auxiliary power supply needed
- > Easy design of system schematic and PCB layout
- > Small form factor design
- > Higher system reliability
- > Shorter development cycles and higher design and production flexibility



Product	Target application	Major difference	Package
IDP2308	TV embedded PSU	2 nd redundant PFC output overvoltage protection	DSO-14 (with enhanced HV creepage distance)
IDP2303A	Adapter, general SMPS	Constant output voltage	DSO-16

IDP2303A – power adapter

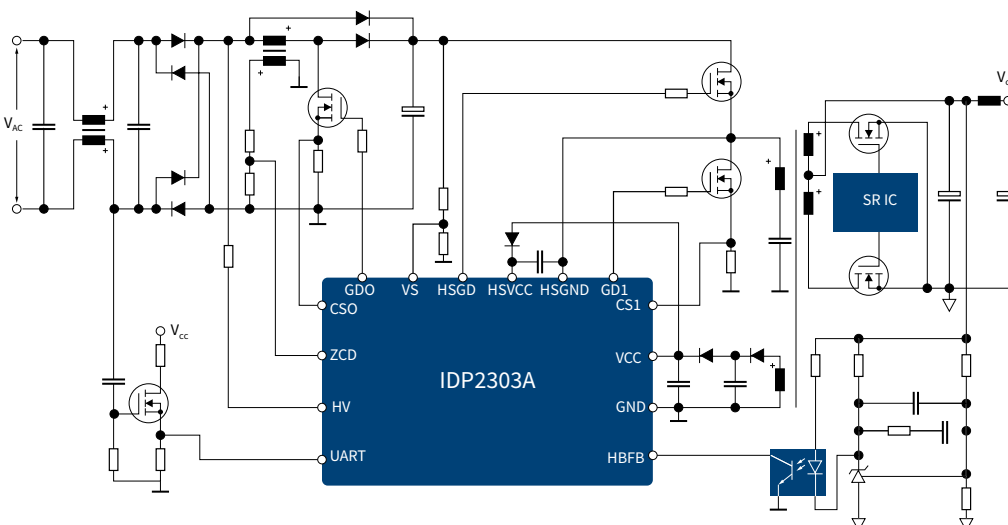

www.infineon.com/xdp-smps



IDP2308 – embedded PSU

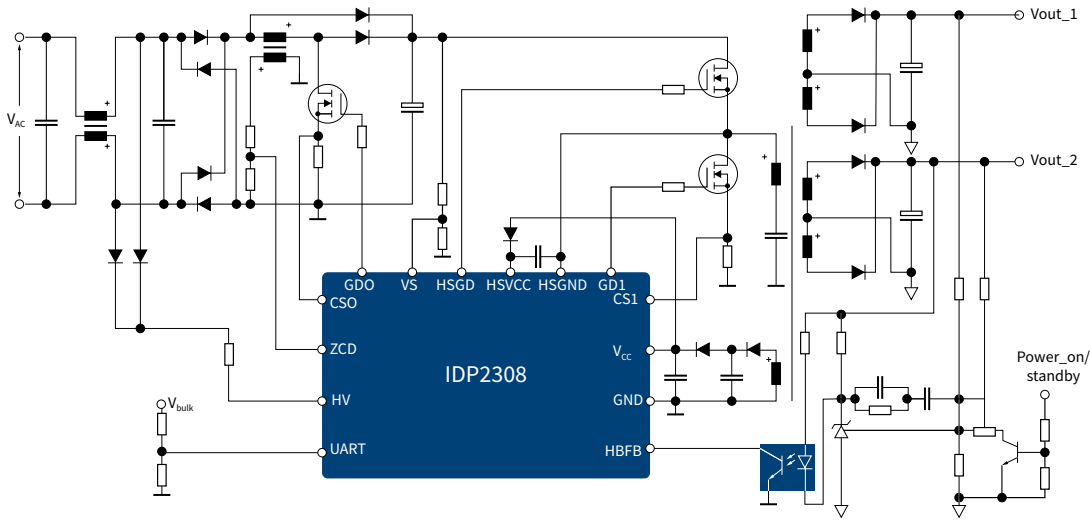

Target applications

- > LCD TV power supply
- > General SMPS
- > Power adapter

www.infineon.com/xdp-smps

Non-isolated DC-DC - integrated power stage

60 A and 70 A with integrated current sense

Infineon's integrated power stage family contains a synchronous buck gate driver IC which is co-packed with control and synchronous MOSFETs and a Schottky diode to further improve efficiency. The package is optimized for PCB layout, heat transfer, driver/MOSFET control timing and minimal switch node ringing when layout guidelines are followed. The paired gate driver and MOSFET combination enables higher efficiency at lower output voltages required by cutting edge CPU, GPU, ASIC and DDR memory designs. The TDA21472 integrated power stages internal MOSFET current sense algorithm, with integrated temperature compensation, achieves superior current sense accuracy versus best-in-class controller based inductor DCR sense methods. Up to 1.0 MHz switching frequency enables high performance transient response, allowing miniaturization of output inductors, as well as input and output capacitors, while maintaining industry-leading efficiency. The TDA21472 is optimized for CPU core power delivery in server applications. The ability to meet the stringent requirements of the server market also makes the TDA21472 ideally suited for powering GPU, ASIC, DDR memory, and other high current designs.

Features

- › Integrated driver, Schottky diode, control MOSFET and synchronous MOSFET
- › 5 mV/A on-chip MOSFET current sensing with temperature compensated reporting
- › Input voltage (V_{in}) range of 4.5 to 15 V
- › V_{CC} and V_{DRV} supply of 4.5 to 7 V
- › Output voltage range from 0.25 up to 5.5 V
- › Output current capability of 70 A
- › Operation up to 1.0 MHz
- › V_{CC} undervoltage lockout (UVLO)
- › 8 mV/°C temperature analog output and thermal flag pull-up to 3.3 V
- › Overtemperature protection (OTP)
- › Cycle-by-cycle self-preservation overcurrent protection (OCP)
- › MOSFET phase fault detection and flag
- › Preliminary overvoltage protection (pre-OVP)
- › Compatible with 3.3 V tri-state PWM input
- › Body-Braking™ load transient support through PWM tri-state
- › Diode emulation mode (DEM) for improved light load efficiency
- › Efficient dual-sided cooling
- › Small 5.0 x 6.0 x 0.9 mm PQFN package

Applications

- › High frequency, high current, low profile DC-DC converters
- › Voltage regulators for CPUs, GPUs, ASICs, and DDR memory arrays

Part type	I_{out} [A]	Package
TDA21472	70	5 x 6 x 0.9 mm PQFN
TDA21462	60	5 x 6 x 0.9 mm PQFN

www.infineon.com/integrated-powerstages

70 A with exposed top for improved thermal performance

Infineon's TDA21475 exposed-top power stage contains a low quiescent-current synchronous buck gatedriver IC co-packaged with high-side and low-side MOSFETs. The package is optimized for PCB layout, heat transfer, driver/MOSFET control timing, and minimal switch node ringing when layout guidelines are followed. The gate driver and MOSFET combination enables higher efficiency at the lower output voltages required by cutting edge CPU, GPU and DDR memory designs.

The TDA21475 internal MOSFET current sense algorithm with temperature compensation achieves superior current sense accuracy versus best-in-class controller-based inductor DCR sense methods. Protection includes cycle-by-cycle over current protection with programmable threshold, V_{CC}/V_{DRV} UVLO protection, bootstrap capacitor undervoltage protection, phase fault detection, IC temperature reporting and thermal shutdown. The TDA21475 also features auto replenishment of the bootstrap capacitor to prevent overdischarging. The TDA21475 features a deep-sleep power saving mode, which greatly reduces the power consumption when the multiphase system enters PS3/PS4 mode. Operation at switching frequency as high as 1.5 MHz enables high performance transient response, allowing reduction of output inductance and output capacitance while maintaining industry-leading efficiency. The TDA21475 is optimized for CPU core power delivery in server applications. The ability to meet the stringent requirements of the server market also makes the TDA21475 ideally suited for powering GPU and DDR memory designs.

Features

- › Co-packaged driver, high-side and low-side MOSFETs
- › 5 mV/A on-chip MOSFET current sensing with temperature compensated reporting
- › Input voltage (V_{IN}) range of 4.25 to 16 V
- › V_{CC} and V_{DRV} supply of 4.25 to 5.5 V
- › Output voltage range from 0.25 up to 5.5 V
- › Output current capability of 70 A
- › Operation up to 1.5 MHz
- › V_{CC}/V_{DRV} undervoltage lockout (UVLO)
- › Bootstrap capacitor undervoltage protection
- › 8 mV/°C temperature analog output
- › Thermal shutdown and fault flag
- › Cycle-by-cycle over current protection with programmable threshold and fault flag
- › MOSFET phase fault detection and flag
- › Auto replenishment of bootstrap capacitor
- › Deep-sleep mode for power saving
- › Compatible with 3.3 V tri-state PWM input
- › Body-Braking™ load transient support
- › Small 5 x 6 x 0.65 mm PQFN package
- › Lead-free RoHS compliant package
- › Integrated driver, Schottky diode, control MOSFET and synchronous MOSFET

Part type	I_{out} [A]	Package
TDA21475	70	5 x 6 x 0.6 mm PQFN

www.infineon.com/integrated-powerstages

20 A with integrated current sense

Infineon's IR35401 integrated power stage contains a synchronous buck gate driver IC, which is co-packaged with control and synchronous MOSFETs and Schottky diode to further improve efficiency. The package is optimized for PCB layout, heat transfer, driver/MOSFET control timing, and minimal switch node ringing when layout guidelines are followed. The paired gatedriver and MOSFET combination enables higher efficiency at lower output voltages required by cutting edge CPU, GPU and DDR memory designs.

The IR35401 power stage features an integrated current sense amplifier to achieve superior current-sense accuracy against best-in-class controller-based inductor DCR sense methods while delivering the clean and accurate current report information. The protection features inside IR35401 include V_{CC} UVLO and thermal flag. IR35401 also features an auto replenishment of bootstrap capacitor to prevent the bootstrap capacitor from overdischarging. The IR35401 supports deep-sleep mode and consumes $<100 \mu A$ V_{CC} bias current when the EN pin is pulled low. Up to 1.5 MHz switching frequency enables high performance transient response, allowing miniaturization of output inductors, as well as input and output capacitors while maintaining industry-leading efficiency. When combined with Infineon's digital controllers, the IR35401 incorporates the Body-Braking™ feature through PWM tri-state which enables reduction of output capacitors. The IR35401 is optimized for low current CPU rails in server applications. The ability to meet the stringent requirements of the server market also makes the IR35401 ideally suited for powering GPU and DDR memory rails.

Features

- › Integrated driver, control MOSFET and synchronous MOSFET
- › Integrated bootstrap synchronous PFET
- › Inductor DCR current sensing with temperature compensation
- › Input voltage (V_{IN}) range from 4.25 to 16 V
- › V_{CC} supply of 4.25 to 5.5 V
- › Output voltage range from 0.5 to 3 V or up to 5.5 V if the internal current sense amplifier is not used
- › Local lossless inductor current sensing with improved noise immunity and accuracy
- › Single reference based current reporting output
- › Output current capability of 20 A
- › Operation up to 1.5 MHz
- › V_{CC} undervoltage lockout
- › Over-temperature and V_{CC} UVLO fault communication to controller via T_{OUT} pin
- › Compatible with 3.3 V tri-state PWM Input
- › Body-Braking™ load transient support through PWM tri-state
- › Auto-replenishment on BOOST pin
- › Low operating quiescent current and $<100 \mu A$ when disabled
- › Small 4 x 5 x 0.9 mm PQFN package
- › Lead-free RoHS compliant package

Applications

- › General purpose POL DC-DC converters
- › Voltage regulators for CPUs, GPUs, ASICs, and DDR memory arrays

Part type	I_{out} [A]	Package
IR35401	20	4 x 5 x 0.9 mm PQFN

www.infineon.com/integrated-powerstages

25 A, 35 A, 40 A power stages

Infineon's TDA21240 powerstage is a multichip module that incorporates Infineon's premier MOSFET technology for a single high-side and a single low-side MOSFET coupled with a robust, high performance, high switching frequency gate driver in a single PG-IQFN-30-2 package. The optimized gate timing allows for significant light load efficiency improvements over discrete solutions. When combined with Infineon's family of digital multi-phase controllers, the TDA21240 forms a complete core voltage regulator solution for advanced micro and graphics processors as well as point-of-load applications.

Features

- › For synchronous buck converter step down voltage applications
- › Maximum average current of 40 A
- › Input voltage range +4.5 V to +16 V
- › Power MOSFETs rated 25 V
- › Fast switching technology for improved performance at high switching frequencies (> 500 kHz)
- › Remote driver disable function
- › Includes bootstrap diode
- › Undervoltage lockout
- › Shoot through protection
- › +5 V high side and low side MOSFETs driving voltage
- › Compatible to standard +3.3 V PWM controller integrated circuits
- › Tri-state PWM input functionality
- › Small package: PG-IQFN-30-2 (4 x 4 x 1 mm)
- › RoHS compliant
- › Thermal warning

Applications

- › Desktop and server VR buck converter
- › Single Phase and multiphase POL
- › CPU/GPU regulation in notebook, desktop graphics cards, DDR memory, graphic memory
- › High power density voltage regulator modules (VRM)
- › Qualified for DC-DC industrial applications based on JEDEC (JESD47, JESD22, J-STD20)
- › General purpose POL DC-DC converters

Part type	I_{out} [A]	Package
TDA21242	25	4 x 4 x 1 mm PQFN
TDA21241	35	4 x 4 x 1 mm PQFN
TDA21240	40	4 x 4 x 1 mm PQFN

Digital controllers

Point-of-load power management

Infineon's digital multiphase and multirail controllers provide power for today's medium and high current POL applications used in telecom/datacom, server, and storage environments. Infineon's digital controller family enables OEMs and ODMs to improve efficiency and total cost of ownership, while increasing power density and optimizing the total system footprint of the voltage regulator. The products highlighted in the table below represent our fifth generation digital controller family and support up to two rails with 1-6 phases on individual rails. The I²C/PMBus™ interface connects the digital controllers to the application system and provides real time telemetry information, monitoring and control capabilities. The digital controllers are fully configurable through our PowerCode™ and PowerClient™ graphical user interfaces that allows for easy to use and simplified design optimization.

Multi-phase configurations are supported for best power optimization

Feature		Controller family							
Configurable output rails		Dual rail	Dual rail	Dual/single rail	Dual/single rail	Dual rail	Dual/single rail	Dual/single rail	Dual rail
Part number	PMBus™	PXE1610C	IR35212	XDPE10280B	XDPE10281B	IR35204	IR35201	IR35223	XDPE132G5C
Phase configuration	Main	7 ph	7 ph	8 ph	8 ph	4 ph	8 ph	10 ph	16 ph
	Subconfigurations	6 + 1	6+1	8+0, 6+2, 4+4	8+0, 6+2, 4+4	3+1	8+0, 7+1, 6+2	10+0, 5+5	8+8
V _{out,max}		2.5 V	3.3 V	3.04 V	3.04 V	3.3 V	3.3 V	3.3 V	3.3 V
Switching frequency		Up to 2 MHz	Up to 2 MHz	Up to 2 MHz	Up to 2 MHz	Up to 2 MHz	Up to 2 MHz	Up to 2 MHz	Up to 2 MHz
Operating temperature range		-5°C to 85°C	-40°C to 85°C	-40°C to 85°C	-40°C to 85°C	-40°C to 85°C	-40°C to 85°C	-40°C to 85°C	-40°C to 120°C
VQFN package		48-lead (6x6) 0.4 mm pitch	48-lead (6x6) 0.4 mm pitch	56-lead (7x7) 0.4 mm pitch	56-lead (7x7) 0.4 mm pitch	40-lead (5x5) 0.4 mm pitch	56-lead (7x7) 0.4 mm pitch	48-lead (6x6) 0.4 mm pitch	56-lead (7x7) 0.4 mm pitch
Typical application		Intel server, high end desktop	Intel server, workstation, high end desktop	Intel server, workstation, high end desktop	AMD server, workstation, high end desktop	AMD server, memory and SOC	AMD server, CPU	Phase redundant based server systems	AMD server, GPU, ASIC, networking ASSP

Advantages of a digital controller

Protection features include a set of sophisticated overvoltage, undervoltage, overtemperature, and overcurrent protections. Each of the controllers in the table above also detect and protect against an open circuit on the remote sensing inputs. These attributes provide a complete and advanced protection feature set for microprocessor, DSP, FPGA or ASIC power systems. Accurate current sense telemetry is achieved through internal calibration that measures and corrects current sense offset error sources upon start-up. Programmable temperature compensation provides accurate current sense information even when using DCR current sense.

Typical multiphase application circuit

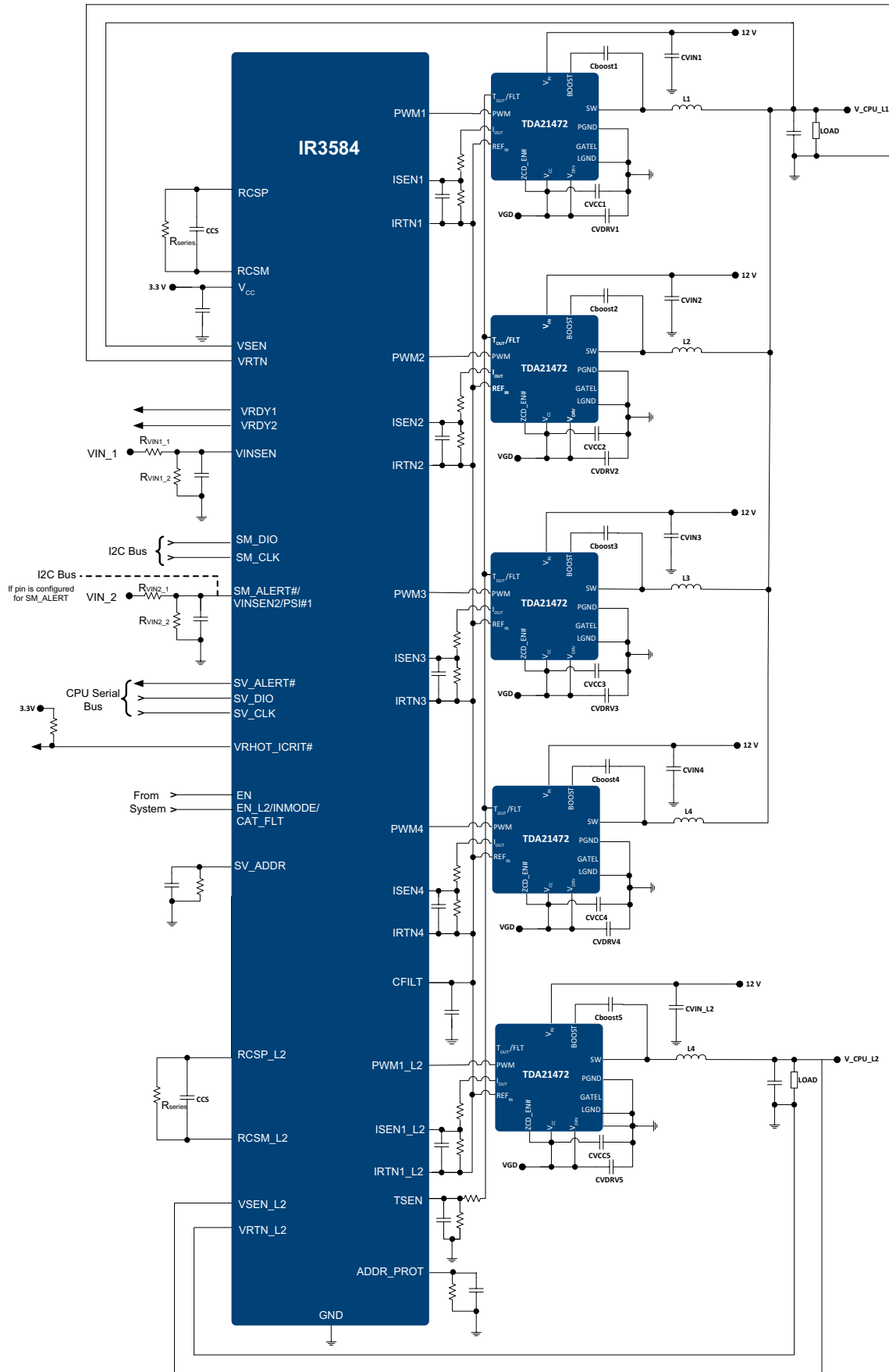

LED driver ICs for general lighting

Professional lighting

Infiniteon's innovative multi-mode LED driver ICs deliver high efficiency, high power factor and low harmonics to LED lighting applications, while supporting dimming levels down to one percent. The high level of integration simplifies designs by reducing the need for external components. The XDP™ digital power technology supports quick design and simplifies logistics handling, hence saving effort and cost.

ICL5101– resonant controller with PFC for LED driver

The ICL5101 integrates a half-bridge controller with a PFC stage in a single package. The high level of integration assures a low count of external components, enabling small form factor designs and making them ideal for compact power supplies in lighting applications, such as LED driver. All operation parameters of the IC are adjustable by simple resistors, which makes them a perfect choice for affordable and reliable configuration. A comprehensive set of protection features including an adjustable external overtemperature protection and capacitive load protection, ensures the detection of fault conditions to increase the system safety.

Features and benefits

- › Secondary-side constant voltage or constant current control
- › PFC in CrCM mode during nominal load and DCM mode in low-load condition down to 0.1 percent for operation without audible noise
- › High-power quality with PF > 0.96, THD < 10 percent
- › Highest efficiency of up to 95 percent due to resonant topology
- › Allows secondary-side IC dimming down to 1 percent
- › PFC/LLC combo IC allows the best matching of PFC stage and LLC stage timing control
- › Supports a wide input voltage range from 90-305 V
- › Ultrafast time to light < 200 ms
- › Complete set of protection features including external thermal protection

Typical application schematic

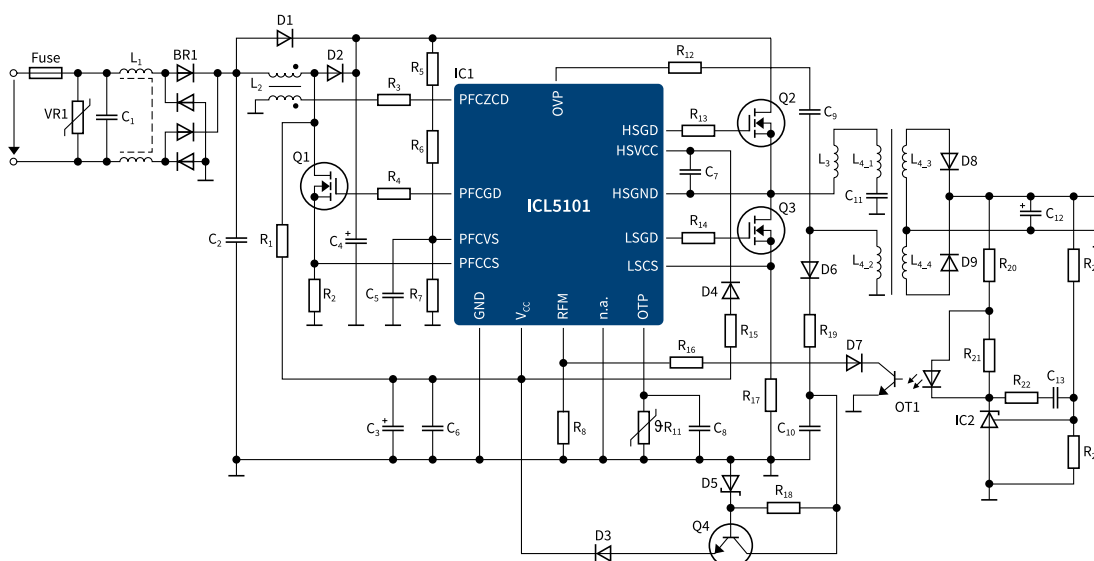

Order information for ICL5101

Type	Description	Ordering code
ICL5101	Resonant controller with PFC	SP001213622
EVALLEDICL5101E1	PFC/LLC evaluation board 110 W	SP001296078

www.infineon.com/icl5101

ICL5102 - High performance PFC + resonant controller for LCC and LLC

Features and benefits

› Small form factor LED driver and low BOM

The high level of integration assures a low count of external components, enabling small form factor designs and making them ideal for compact and slimline power supplies for lighting, such as LED driver for indoor and outdoor applications

› High performance, digital PFC and advanced HB driver

The high performance digital PFC stage achieves power factor of 99 percent, through operation in CrCM and DCM mode, in a frequency range of 22 to 500 kHz. This supports stable operation even at low-load conditions down to 0.1 percent of the nominal power without audible noise

› Fast time-to-light and low standby

With start-up current of less than 100 μ A the controller provides very fast time-to-light within less than 300 ms, while standby the controller changes into active burst mode which reduces power consumption to less than 300 mW

› Safety first

The controller has a comprehensive set of protection features built in to increase the system safety. It monitors in the run mode the complete system regarding bus over- and undervoltage, open loop, overcurrent of PFC and/or inverter, output overvoltage, overtemperature and capacitive load operation

Typical application schematic

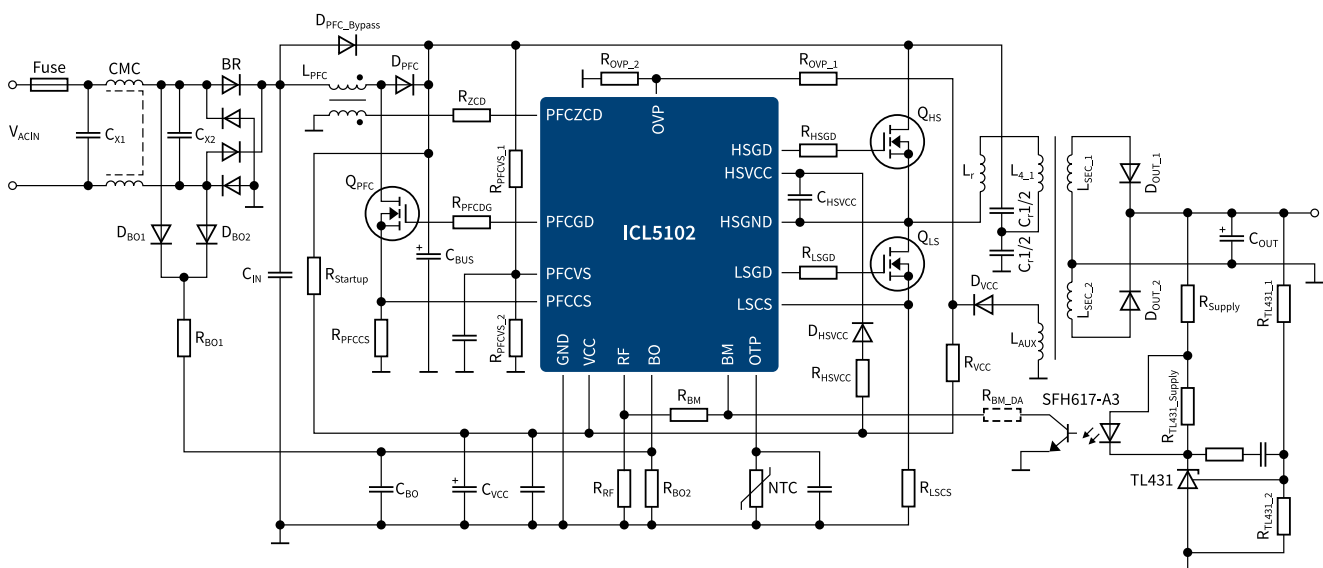

Order information for ICL5102

Type	Description	Ordering code
ICL5102	PFC and resonant controller for LCC and LLC	SP002224374
EVAL-ICL5102-U130W-CC	PFC/LLC-CC constant current evaluation board 130 W LED driver	SP001667160

XDP™ LED

The IC family XDP™ is the first all-in-one package solutions combining a digital controller with key power peripherals. Such integration provides exceptional flexibility and performance. The XDP™ family addresses essential features for advanced LED driver.

XDPL8105 – digital flyback controller IC for LED driver

The XDPL8105 is a digital, single-stage flyback controller with high power factor for constant current LED driver. The device offers versatile functions for different indoor and outdoor lighting applications. The IC is available in a DSO-8 package and it provides a wide feature set, requiring a minimum of external components. The advanced control algorithms in the digital core of the XDPL8105 provide multimode operation for high efficiency. Configurable parameters allow last minute changes, shorten the product development and reduce hardware variants. The extensive set of configurable standard and sophisticated protection mechanisms ensure safe, reliable and robust LED driver device for diverse use cases.

Features and benefits

- › Constant current with primary side regulation
- › Supports AC and DC input
- › Nominal input voltage range 90-305 V_{AC} or 120-350 V_{DC}
- › Integrated 600 V start-up cell
- › Power factor > 0.9 and THD < 15 percent over wide load range
- › Highly accurate primary side control output current typ. ± 3 percent
- › Reference board efficiency > 90 percent
- › Internal temperature guard with adaptive thermal management
- › Multimode operation
 - QRM (quasi-resonant mode)
 - DCM (discontinuous conduction mode)
 - ABM (active burst mode)
- › Digital parameters
- › Relevant error conditions are monitored and protected
 - Undervoltage
 - Overvoltage
 - Open load
 - Output shorted

Typical application schematic

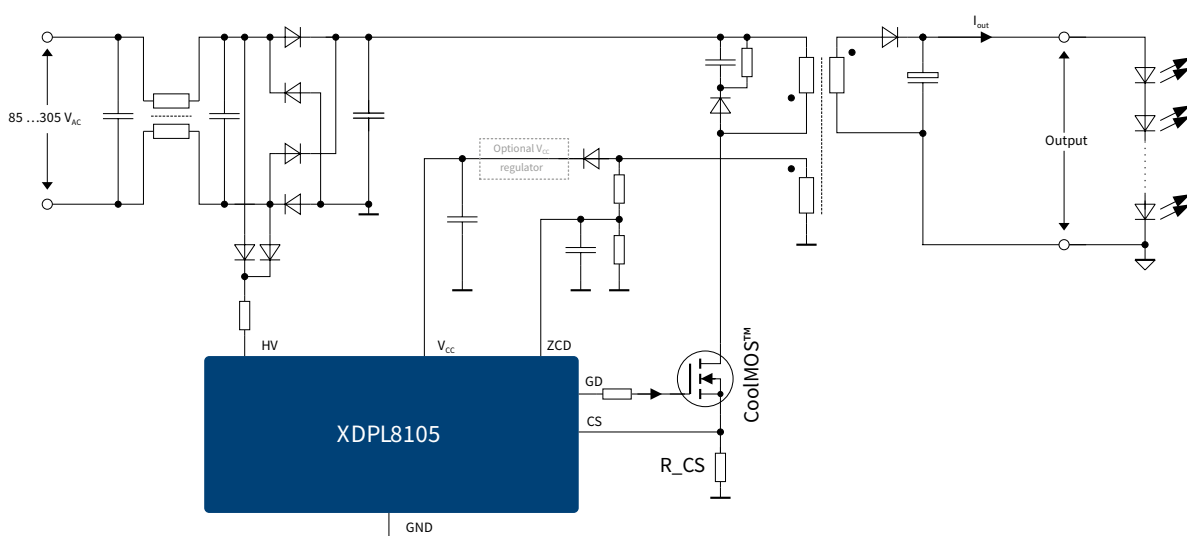

Order information for XDPL8105

Type	Description	Ordering code
XDPL8105	Digital flyback controller IC	SP001639446
REF-XDPL8105-CDM10V	40 W reference design with CDM10V isolated 0 V-10 V dimming interface	SP001649474

www.infineon.com/xdpl8105

XDPL8210 – digital flyback constant current controller IC for LED driver with 1 percent dimming

The XDPL8210 is a digital, single-stage, quasi-resonant flyback controller with high power factor and high precision primary side controlled constant current output. The IC is available in a DSO-8 package and it provides a wide feature set, which requires only a small number of external components. Sophisticated algorithms provide flicker-free dimming below one percent. The driver fully supports IEC61000-3-2 class C designs. The limited power mode improves functional safety, while configurable parameters allow last minute changes, shorten the product development and reduce hardware variants. The extensive set of configurable standard and sophisticated protection mechanisms ensure safe, reliable and robust LED driver for a large set of use cases.

Features and benefits

- › Constant current with primary side regulation
- › Supports AC and DC input
- › Nominal input voltage range 90-305 V_{AC} or 90-430 V_{DC}
- › Reference board efficiency > 90 percent
- › Power factor > 0.9 and THD < 15 percent over wide load range
- › Standby power < 100 mW
- › Internal temperature guard with adaptive thermal management
- › Multimode operation
 - QRM (quasi-resonant mode)
 - DCM (discontinuous conduction mode)
 - ABM (active burst mode)
- › Digital parameters
- › Relevant error conditions are monitored and protected
 - Undervoltage
 - Overvoltage
 - Open load
 - Output shorted

Typical application schematic

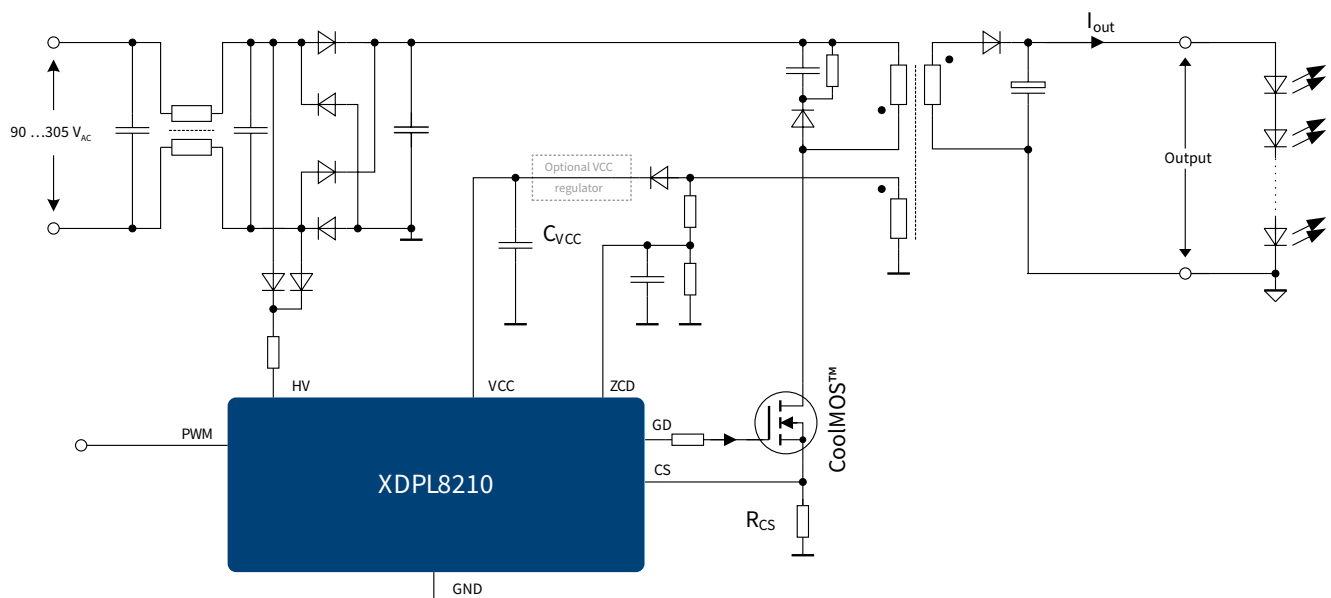

Order information for XDPL8210

Type	Description	Ordering code
XDPL8210*	Digital flyback constant current controller IC	SP001643692
REF-XDPL8210-U35W	35 W reference design with CDM10V isolated 0 V-10 V dimming interface	SP001886070

www.infineon.com/xdpl8210

* coming Q1/2019

XDPL8218 – high power factor constant voltage flyback IC with secondary side regulation

The XDPL8218 is a digital, highly integrated, future-proof device combining a constant voltage quasi-resonant flyback controller with algorithms for high power factor and low THD. The main application field for XDPL8218 are dual stage designs with a DC-DC stage at secondary side and XDPL8218 as primary side. The device manages wide load ranges and reacts fast and stable to dynamic load changes. The digital core of the XDPL8218 enables high efficiency over full output power range, multimode operation with quasi-resonant switching at high power, discontinuous conduction mode frequency reduction at medium power and active burst mode at low power. The XDPL8218 is available in a DSO-8 package.

Wide input voltage range

- › Constant voltage with secondary side regulation
- › Supports AC and DC input
- › Nominal input voltage range 100-305 V_{AC} or 90-430 V_{DC}
- › Reference board efficiency > 90 percent
- › Power factor > 0.9 and THD < 15 percent over wide load range
- › Standby power < 100 mW
- › Internal temperature guard with adaptive thermal management
- › Brown-out and brown-in protections
- › Embedded digital filters
- › Multimode operation
 - QRM (quasi-resonant mode)
 - DCM (discontinuous conduction mode)
 - ABM (active burst mode)
- › Digital parameters
- › Relevant error conditions are monitored and protected
 - Undervoltage
 - Overvoltage
 - Open load
 - Output shorted

Typical application schematic

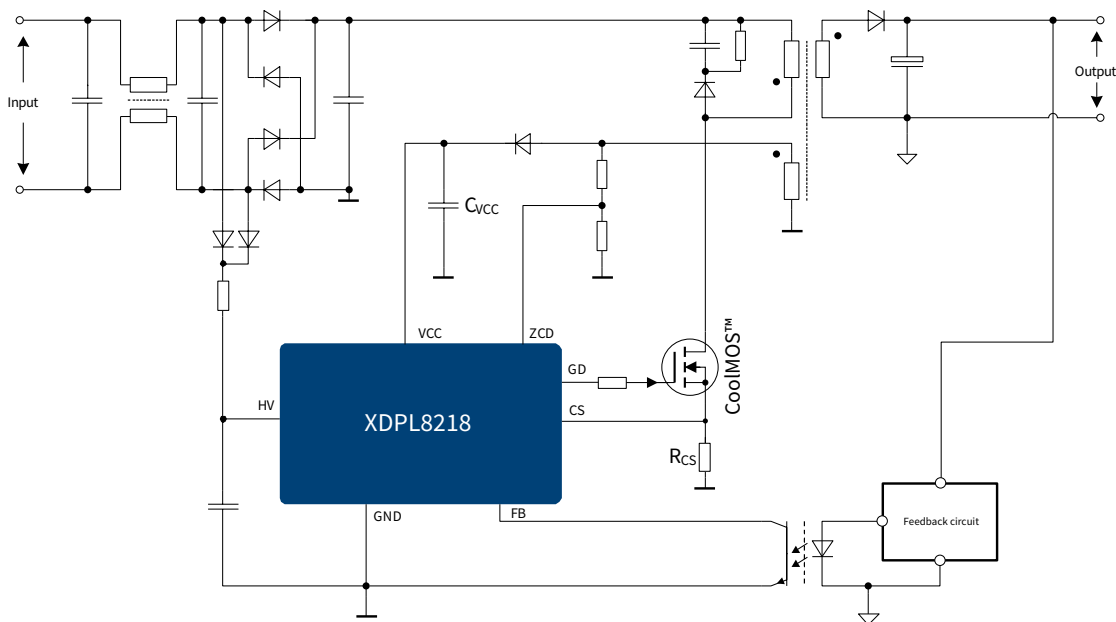

Order information for XDPL8218*

Type	Description	Ordering code
XDPL8218*	Digital flyback CV-output controller IC	SP001707258
REF-XDPL8218-U40W	40 W reference board with replaceable feedback circuit	SP001710980

www.infineon.com/xdpl8218

* coming Q1/2019

XDPL8220 - digital dual stage multi-mode flyback controller for CC, CV, LP with primary side regulation

The XDPL8220 simplifies for the lighting industry to realize essential features for smart lighting and increases the benefits to the end user and the luminaire manufacturers. The XDPL8220 is a digital, highly integrated, future-proof device combining a quasi-resonant PFC plus a quasi-resonant flyback digital controller with primary side regulation. The multi control features - constant voltage, constant current, and limited power - enable a highly versatile LED driver (e.g. window LED driver). The main application field of the XDPL8220 is advanced dual stage LED driver for indoor or outdoor lighting. The IC is available in a DSO-16 package.

Features and benefits

- › Constant current, constant voltage, limited power with primary side regulation
- › PWM dimming input controls respective analog output current
- › Reference board efficiency > 90 percent
- › Power factor > 0.9 and THD < 15 percent over wide load range
- › Nominal input voltage range 100-305 V_{AC} or 90-430 V_{DC}
- › Standby power < 100 mW
- › Internal temperature guard with adaptive thermal management
- › Multimode operation
 - QRM (quasi-resonant mode)
 - DCM (discontinuous conduction mode)
 - ABM (active burst mode)
- › Digital parameters
- › Relevant error conditions are monitored and protected
 - Undervoltage
 - Overvoltage
 - Open load

Typical application schematic

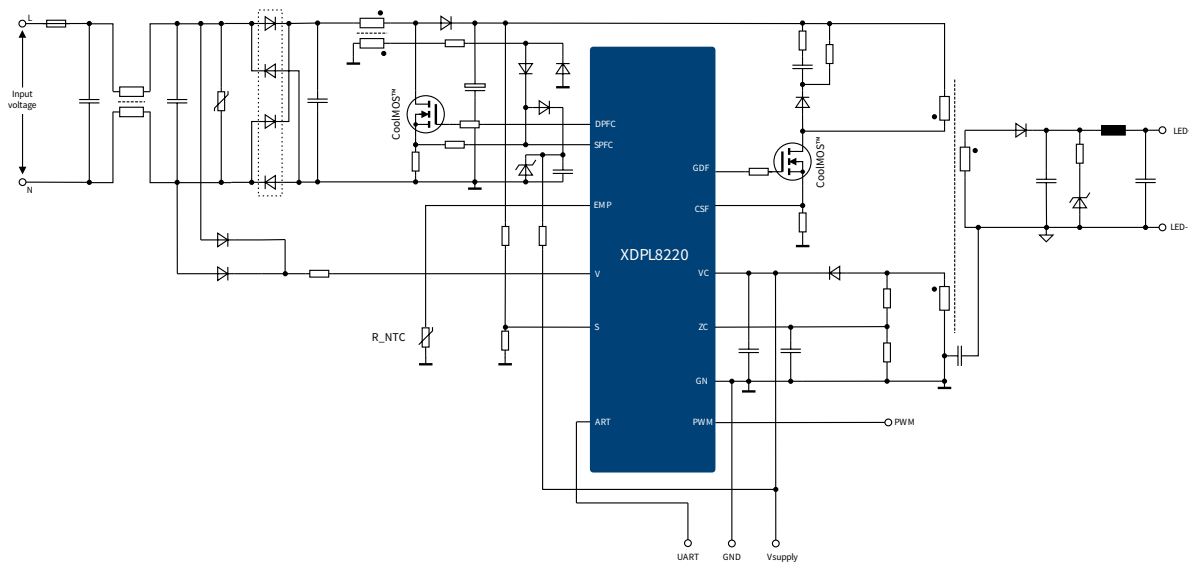

Order information for XDPL8220

Type	Description	Ordering code
XDPL8220	Digital dual stage multimode flyback Controller for CC, CV, LP	SP001398160
REF-XDPL8220-U30W	30 W reference board with CDM10V isolated 0 V-10 V dimming interface	SP001630060
REF-XDPL8220-U50W	50 W reference board with CDM10V isolated 0 V-10 V dimming interface	SP001630066
REF-XDPL8220-U100W	100 W reference board with CDM10V isolated 0 V-10 V dimming interface	SP001630068

www.infineon.com/xdpl8220

XDPL8221 - digital dual stage multi-mode flyback controller for CC, CV, LP with 1 percent dimming and serial interface

The XDPL8221 is a digital, highly integrated, future-proof device combining a quasi-resonant PFC with a quasi-resonant flyback controller with primary side regulation. A serial communication interface supports direct communication with an external microcontroller unit (MCU). The XDPL8221 is especially designed for advanced LED driver in smart lighting or IoT applications, featuring flicker-free dimming down to 1 percent of nominal current. The device enables customizable LED driver and simplifies the generation and maintenance of different variants without increasing the number of stock keeping units. The IC is available in a DSO-16 package.

Features and benefits

- › Nominal input voltage range 100-305 V_{AC} or 90-430 V_{DC}
- › Reference board efficiency > 90 percent
- › Power factor > 0.9 and THD < 15 percent over wide load range
- › UART Interface for control and real-time monitoring
- › Constant current, constant voltage, limited power with primary side regulation
- › 1 percent dimming
- › Dim-to-off with low standby power < 100 mW
- › Internal temperature guard with adaptive thermal management
- › The UART interface and the command set enable to control the function of the XDPL8221 or inquire status information
- › Multimode operation
 - QRM (quasi-resonant mode)
 - DCM (discontinuous conduction mode)
 - ABM (active burst mode)
- › Digital parameters
- › Relevant error conditions are monitored and protected
 - Undervoltage
 - Overvoltage
 - Open load
 - Output shorted

Typical application schematic

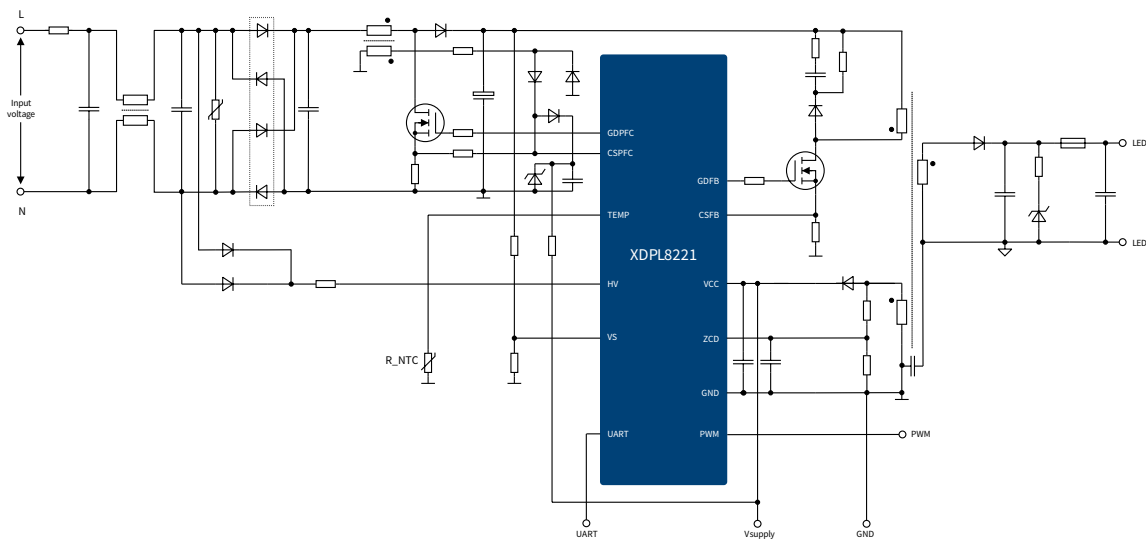

Order information for XDPL8221*

Type	Description	Orderable part number
XDPL8221*	Digital dual stage multimode flyback Controller for CC, CV, LP with 1 percent dimming	XDPL8221XUMA1
REF-XDPL8221-U50W	50 W reference board with CDM10V isolated 0 V-10 V dimming interface	REFXDPL8221U50WTOBO1
REF-XDPL8221-U100W	100 W reference board with CDM10V isolated 0 V-10 V dimming interface	REFXDPL8221U100WTOBO1

www.infineon.com/xdpl8221

* coming Q1/2019

Linear current regulators

60 V linear LED controller IC with voltage feedback loop to primary side

The BCR601 is a linear LED controller IC regulating the LED current with an external driver transistor. The device supports either NPN bipolar transistors or N-channel MOSFETs to cover a wide LED current and power range up to several hundred milliamperes. The BCR601 provides feedback to the primary side via an optocoupler to control the output voltage of the primary side converter, e.g. a flyback. The control loop minimizes the voltage overhead and power dissipation of the external driver transistor. The voltage overhead can be adjusted by external configuration according to applications needs.

Features and benefits

- > Supports an optocoupler feedback loop to primary side minimizing power losses
- > Suppresses the voltage ripple of the power supply driving a constant LED current for high light quality
- > The embedded hot plug protection allows plug in and plug out of any LED load during operation without damaging the LEDs
- > Supports wide current range depending on external driver transistor
- > Supply voltage range up to 60 V
- > Gate driver current 10 mA
- > LED current can be adjusted by R_{set} functionality
- > Overtemperature protection and adjustable overvoltage protection



Typical application schematic

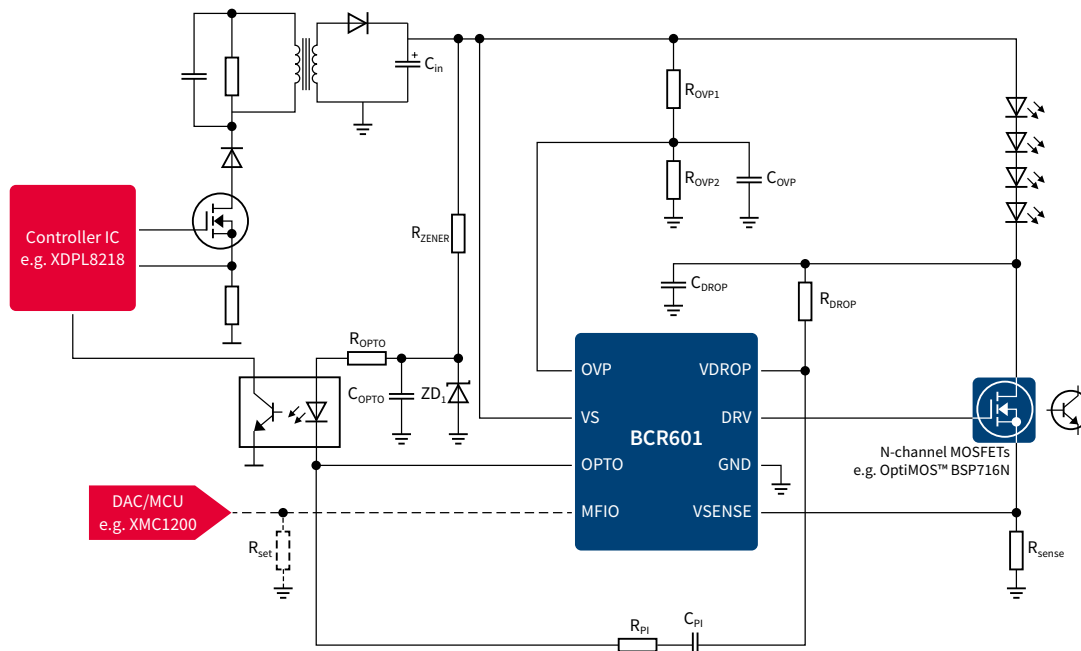

Order information for BCR601

Type	Description	Ordering code
BCR601	60 V linear LED controller IC with voltage feedback to primary side	SP001681722
DEMO_BCR601_60V_IVCTRL	Demonstration board BCR601 current and voltage control, 500 mA	SP002798056

60 V linear LED controller IC for dimmable LED applications

The BCR602 is a linear LED controller IC regulating the LED current with an external driver transistor. The BCR602 supports either NPN bipolar transistor or N-channel MOSFETs to cover a wide LED current and power range up to several amperes. The LED current is fully scalable by dimensioning an external current sense resistor.

Features and benefits

- › Suppresses the voltage ripple of the power supply driving a constant LED current for high light quality
- › The LED current can be dimmed by resistors as well as analog or digital PWM voltages connected to the multifunction input-output (MFIO) pin
- › The embedded hot plug protection allows plug in and plug out of any LED load during operation without damaging the LEDs
- › Supports wide current range depending on external driver transistor
- › Supply voltage range up to 60 V makes it ideal for 48 V designs
- › Gate driver current 10 mA
- › LED current can be adjusted by Rset functionality
- › Overtemperature protection



Typical application schematic

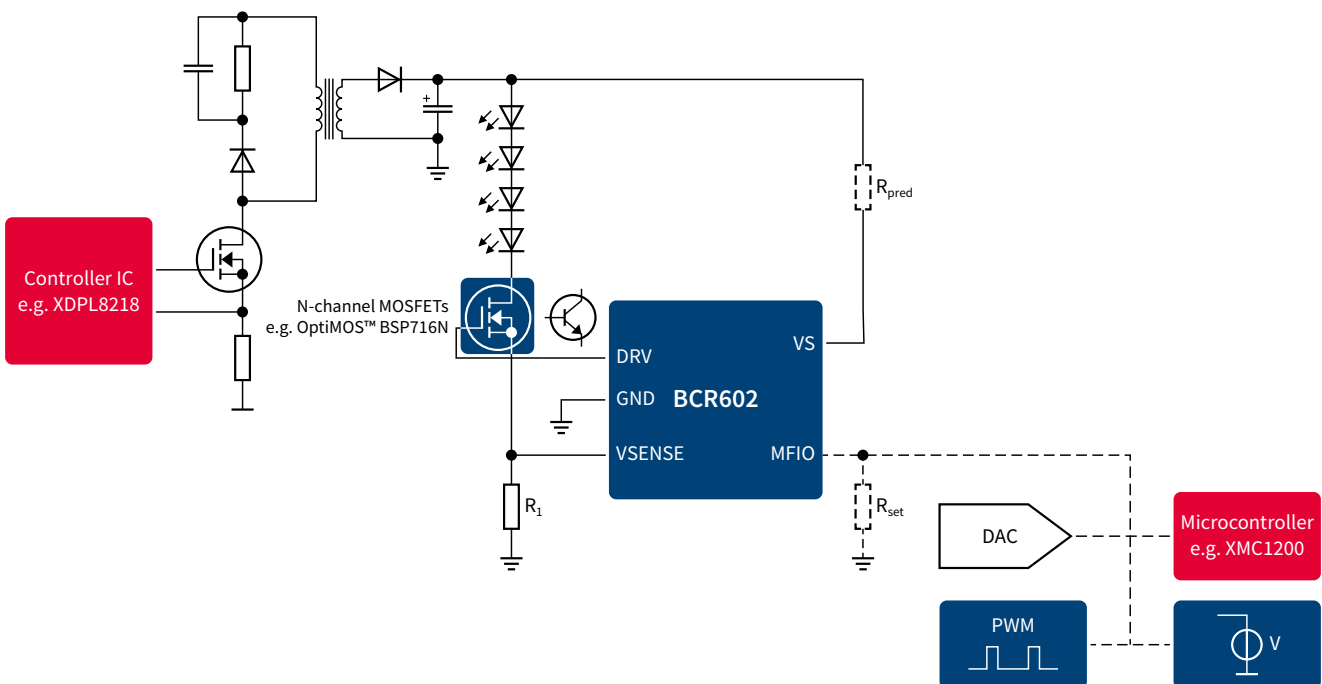

Order information for BCR602

Type	Description	Ordering code
BCR602	60 V linear LED controller IC	SP001681730
DEMO_BCR602_60V_IVCTRL	Demonstration board BCR602U current control, 200 mA	SP002798054

BCR40x linear LED Driver ICs for low power LEDs

The BCR40x family is the smallest size and lowest cost series of LED drivers. These products are perfectly suited for driving low power LEDs in general lighting applications. Thanks to AEC-Q101 qualification, it may also be used in automotive applications such as brake lights or interior.

The advantage over resistor biasing is:

- › Long lifetime of LEDs due to constant current in each LED string
- › Homogenous LED light output independent of LED forward voltage binning, temperature increase and supply voltage variations

The advantage versus discrete semiconductors is:

- › Reduced part count and assembly effort
- › Pretested output current
- › Defined negative temperature co-efficient protection

Needing more details on replacing resistors?



Take a look at the application note "Driving low power LEDs from 10 to 65 mA LED driver ICs with BCR401W and BCR402W family"

Features and benefits:

- › Output current from 10 to 100 mA (adjustable by external resistor)
- › Supply voltage up to 18 V (BCR401W, BCR402W) and up to 40 V (BCR401U, BCR402U, BCR405U, BCR430U)
- › Reduction of output current at high temperature, contributing to long lifetime LED systems
- › Ease of use
- › Very small form factor packages with up to 750 mW max. power handling capability

Low-power LED driver ICs (5-100 mA)

Type	Group	Topology	V_s (min.) [V]	V_s (max.) [V]	I_{out} (typ.) [mA]	I_{out} (max.) [mA]	Dimming	Package	P_{tot} (max.) [mW]
BCR401U	LED drivers for low-power LEDs	Linear	1.4	40	10.0	65	PWM by ext. transistor	SC74	750
BCR401W	LED drivers for low-power LEDs	Linear	1.2	18	10.0	60	PWM by ext. transistor	SOT343	500
BCR402U	LED drivers for low-power LEDs	Linear	1.4	40	20.0	65	PWM by ext. transistor	SC74	750
BCR402W	LED drivers for low-power LEDs	Linear	1.4	18	20.0	60	PWM by ext. transistor	SOT343	500
BCR405U	LED drivers for low-power LEDs	Linear	1.4	40	50.0	65	PWM by ext. transistor	SC74	750
BCR430U NEW	LED driver for low-power LEDs	Linear	6	42	Defined by R_{set}	100	PWM by ext. transistor	SOT23	600

NEW: Ultralow voltage drop version BCR430U with only 135 mV at 50 mA

LED current versus voltage drop ($V_s = 24$ V)

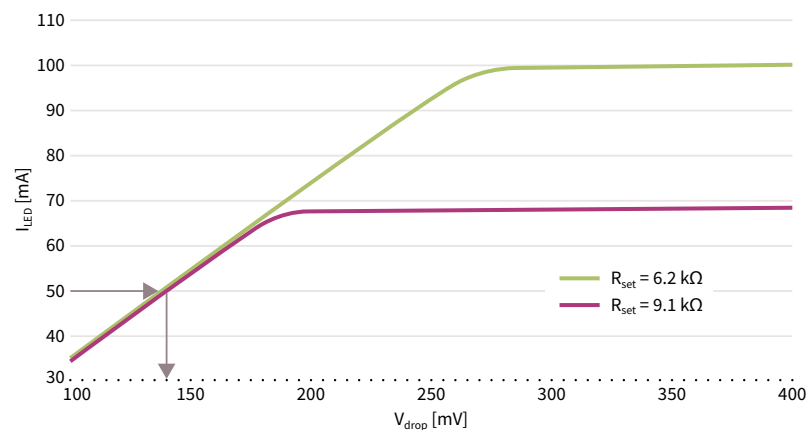

The voltage drop at the integrated LED driver stage can go down to 135 mV at 50 mA and less improving the overall system efficiency and providing extra voltage headroom to compensate for tolerances of LED forward voltage or supply voltage. With the BCR430U, additional LEDs can be added to lighting designs without changing the supply voltage.

www.infineon.com/bcr

BCR32x/BCR42x/BCR450/BCR601/BCR602 linear LED driver and controller ICs for medium and high power LEDs

The BCR32x and BCR42x LED drivers are dedicated linear regulators for 0.5 W LEDs with a maximum output current of 250 mA. They are optimized in terms of cost, size and feature set for medium power LEDs in general lighting applications. Thanks to AEC-Q101 qualification, it may also be used in automotive applications such as brake lights or interior.

Features and benefits

- › Output current from 10 mA up to 300 mA for BCR32x (200 mA for BCR42xU), adjustable by external resistor
- › Supply voltage up to 40 V for BCR42x (24 V for BCR32x)
- › Direct microcontroller interface for PWM dimming with BCR321U/BCR421U
- › Reduction of output current at high temperature, contributing to long lifetime LED systems
- › Ease of use
- › Very small form factor packages with up to 1000 mW max. power handling capability

Medium- and high-power LED driver ICs

Type	Group	Topology	V_s (min.) [V]	V_s (max.) [V]	I_{out} (typ.) [mA]	I_{out} (max.) [mA]	Dimming	Package	P_{tot} (max.) [mW]
BCR320U	LED drivers for mid-power LEDs	Linear	1.4	24	250	300	No	SC74	1000
BCR321U	LED drivers for mid-power LEDs	Linear	1.4	24	250	300	Digital input	SC74	1000
BCR420U	LED drivers for mid-power LEDs	Linear	1.4	40	150	200	No	SC74	1000
BCR421U	LED drivers for mid-power LEDs	Linear	1.4	40	150	200	Digital input	SC74	1000
BCR450	LED controller	Linear	3.0	27	70	Ext. switch	Digital input	SC74	500
BCR601	LED controller	Linear	8.0	60	Ext. switch	Ext. switch	Analog	PG-DSO-8	360
BCR602	LED controller	Linear	8.0	60	Ext. switch	Ext. switch	Analog/PWM	PG-SOT23-6	360

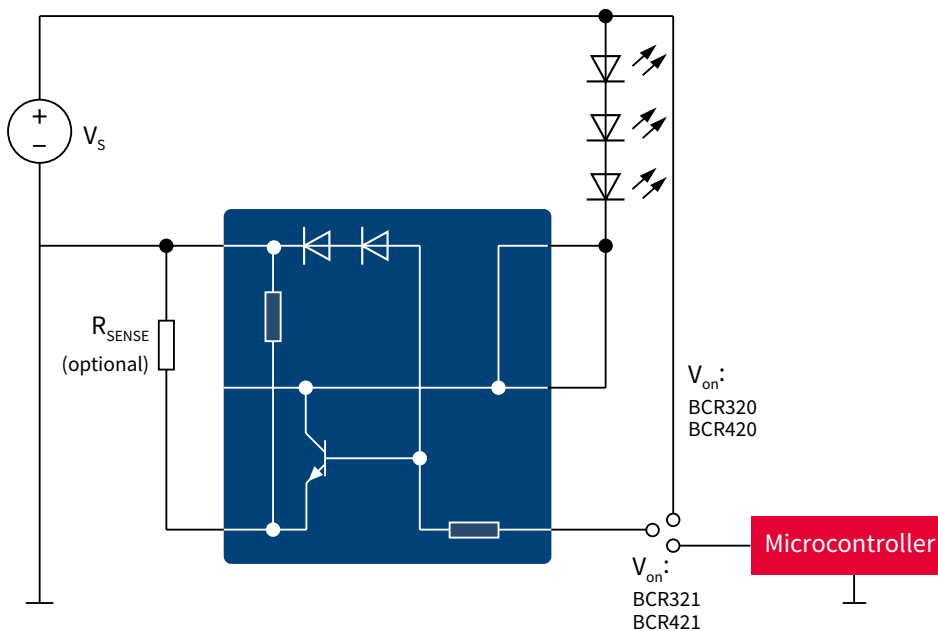

DC-DC switch mode LED driver ICs

ILD8150/ILD8150E* – 80 V DC-DC buck LED driver IC for high-power LEDs and high-performance hybrid dimming

The ILD8150 is 80 V DC-DC converter IC, designed to be used in LED applications to drive high power LEDs. For applications operating close to safe extra low voltage (SELV) limits, it provides a high safety voltage margin. The buck LED driver IC is tailored for LEDs in general lighting applications with average currents up to 1.5 A using a high-side integrated switch. Several performance and protection features provide the right fit for professional LED lighting.

The hysteretic current control provides an extremely fast regulation and stable LED current combined with good EMI performance. The efficiency of the LED driver IC is remarkably high, reaching more than 95 percent efficiency over a wide range. A PWM input signal between 250 Hz and 20 kHz controls dimming of the LEDs current in analog mode from 100 to 12.5 percent and 12.5 to 0.5 percent in PWM mode with flicker-free modulation frequency of 3.4 kHz.

Digital PWM dimming detection with high resolution makes ILD8150/E the perfect LED driver IC for the use together with microcontrollers. Precise output current accuracy from device to device under all loads and input voltages conditions makes it perfect for tunable white and flat panel designs where current must be identical string to string.

Features and benefits

- › Wide input voltage ranging from 8–80 V_{DC}
- › Up to 1.5 A average output current, adjustable via shunt resistor
- › Efficiency > 95 percent
- › Up to 2 MHz switching frequency
- › Soft-start
- › PWM dimming input, with 250 Hz to 20 kHz PWM dimming frequency
- › Hybrid dimming for flicker free light down to 0.5 percent
 - Analog dimming 100 percent – 12.5 percent
 - PWM dimming 12.5 percent – 0.5 percent with 3.4 kHz flicker-free modulation, dim-to-off
- › Typical 3 percent output current accuracy
- › Overtemperature protection
- › Pull-down transistor to avoid LED glowing in dim-to-off
- › DSO-8 package to enable wave soldering
- › DSO-8 with exposed pad for higher thermal performance (ILD8150E)

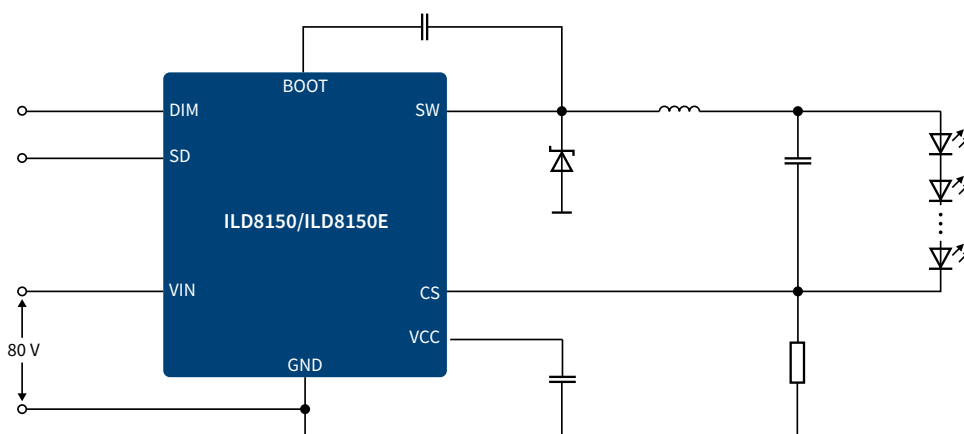

Type	Description	Ordering code	Package
ILD8150	80 V DC-DC buck LED driver IC	SP001805682	DSO-8
ILD8150E	80 V DC-DC buck LED driver IC	SP001805686	DSO-8 exposed pad
REF_ILD8150_DC_1.5A	Reference design board 1.5 A	SP002798058	Board with ILD8150E

www.infineon.com/lowcostledriver

* coming Q2/2019

DC-DC switch mode LED driver ICs

ILD series DC-DC switch mode LED driver ICs

The ILD series are switch mode LED driver ICs for high power LEDs. They combine protection features that contribute to the lifetime of LEDs with the flexibility in output current range up to multiple amperes. The new ILD series include LED driver ICs with integrated power stage, as well as with external MOSFET achieving up to 98 percent driver efficiency across a wide range of general lighting applications.

Features and benefits

- › Wide input voltage range up to 80 V
- › Scalability in output current from 90 mA up to multiple amperes
- › Alternative dimming concepts: digital or analog
- › Hybrid dimming: analog and digital output combined for flicker free light down to 0.5 percent realized with ILD8150
- › Superior adjustable overtemperature protection for ILD6150 and ILD6070 contributing to longer LED lifetime
- › Overvoltage and overcurrent protection
- › ILD1151 supports boost, buck-boost and SEPIC topologies

Type	V_i (min.) [V]	V_i (max.) [V]	I_{out} (typ.) [mA]	I_{out} (max.) [mA]	Package	Dimming	Topology	f_{sw}	Features
ILD1151	4.5	45	90	3.000	SSOP-14	Analog/digital	Boost, buckboost SEPIC	Adjustable 100 kHz-500 kHz	Multi topology controller, constant current or constant voltage mode, overvoltage, overcurrent, short on GND protection
ILD6070	4.5	60	Selectable by resistor	700	DSO-8 exposed pad	Digital output	Hysteretic buck	1 MHz	Integrated switch rated up to 700 mA, PWM or analog dimming input, adjustable overtemperature protection, overcurrent protection
ILD6150	4.5	60	Selectable by resistor	1.500	DSO-8 exposed pad	Digital output	Hysteretic buck	1 MHz	Integrated switch rated up to 1.500 mA, PWM or analog dimming input, adjustable overtemperature protection, overcurrent protection
ILD8150*	8	80	Selectable by resistor	1.500	DSO-8	Hybrid (analog down to 12% and PWM down to 0,5%) dimming output	Hysteretic buck	2 MHz	Integrated 80 V switch rated up to 1.500 mA with low $R_{DS(on)}$, hybrid dimming down to 0.5%, UVLO, thermal protection, digital soft-start, flicker-free operation
ILD8150E*	8	80	Selectable by resistor	1.500	DSO-8 exposed pad	Hybrid (analog down to 12% and PWM down to 0,5%) dimming output	Hysteretic buck	2 MHz	Integrated 80 V switch rated up to 1.500 mA with low $R_{DS(on)}$, hybrid dimming down to 0.5%, UVLO, thermal protection, digital soft-start, flicker-free operation

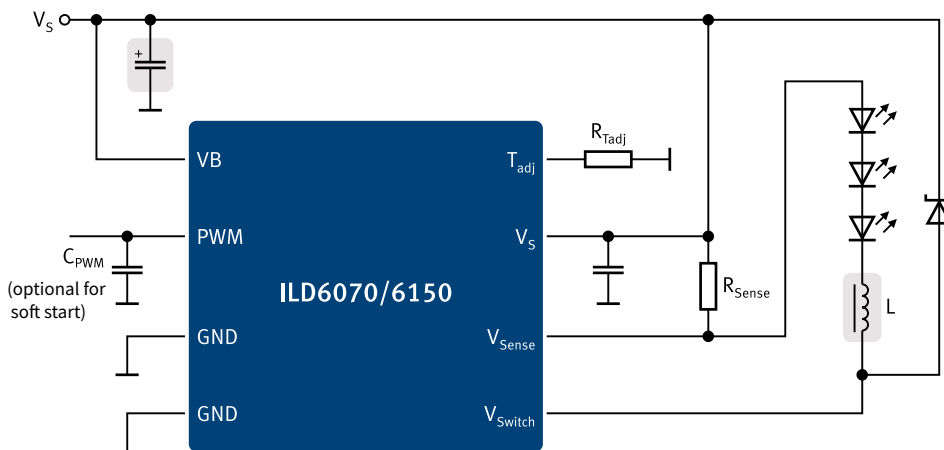

www.infineon.com/ild

* coming Q2/2019



Packages

XENSIV™ sensors

Microcontrollers

Motor control ICs

Gate driver ICs

Power ICs

Discrete IGBTs

WBG semiconductors

500-950 V MOSFETs

20-300 V MOSFETs

Applications

CDM10V and CDM10VD – most flexible dimming interface ICs for 0–10 V

Infineon’s fully integrated dimming solutions

Infineon’s CDM10V and CDM10VD are the industry’s first single-chip lighting interface ICs. They are capable of transforming an analog 0–10 V input into a PWM or dimming input signal, required by a lighting controller IC. CDM10V and CDM10VD devices are dedicated for commercial and industrial LED lighting applications. The compact and highly integrated devices allow designers to replace up to 25 discrete components, used in conventional 0–10 V dimming schemes, with a single device. Supplied in an ultra-miniature 6-pin SOT package, the CDM10Vx and CDM10VDx perfectly match small PCBs with high component densities.

Key features

- › Active dimming (0–10 V) and passive dimming (resistor)
- › Embedded digital signal processing which maintains minimum variations from device to device
- › PWM input
- › One-time configurable device: CDM10V and preconfigured devices with various feature sets

Key benefits

- › Single-device solution leading to low BOM and PCB savings
- › Dimming ICs in small SOT-23 package for high power density designs
- › Granular portfolio for highest flexibility and easy design-in
- › Wide input V_{CC} range 11–25 V, extended range down to 6 V for CDM10V
- › Attractive pricing and faster time to market

Product type	I_{out} [mA]	Min. duty cycle [%]	PWM output frequency [kHz]	Dimmer/resistor bias current [μ A]	Dimm-to-Off	OPN	SP number
CDM10V	5	1/2/5/10	0.2/0.5/1/2	50/100/200/500	Disabled/enabled	CDM10VXTSA1	SP001424754
CDM10V-2	5	n.a.	1	200	Enabled	CDM10V2XTSA1	SP001684884
CDM10V-3	5	1	1	200	Disabled	CDM10V3XTSA1	SP001715882
CDM10V-4	5	n.a.	2	100	Enabled	CDM10V4XTSA1	SP001727960
CDM10VD	5	5	1	120	Enabled	CDM10VDXTSA1	SP001619792
CDM10VD-2	5	10	1	120	Enabled	CDM10V2DXTSA1	SP001619794
CDM10VD-3	1	5	1	120	Enabled	CDM10V3DXTSA1	SP001619796
CDM10VD-4	1	10	1	120	Enabled	CDM10V4DXTSA1	SP001630006

Board name	Description	SP number
COOLDIM_PRG_BOARD	Configuration board for CDM10V only	SP001493166
REF-XDPL8220-U30W	30 W two stage PFC FB digital power, efficient and flicker free reference design with CDM10V	SP001630060
REF-XDPL8105-CDM10V	40 W single stage PFC FB digital power reference design with CDM10V	SP001649474

Typical application schematic using CDM10V

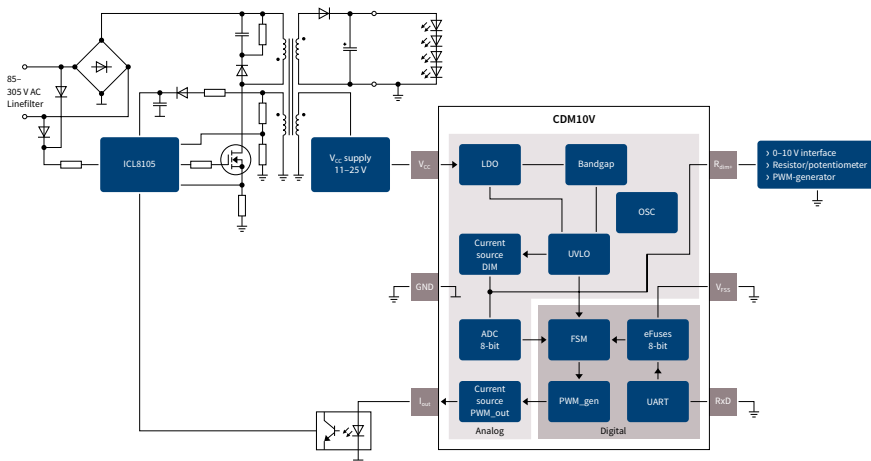

www.infineon.com/cdm10v

Ballast control ICs

Infineon's solutions for fluorescent lamps

Ballast control ICs from Infineon integrate all functions required to operate FL lamps such as preheat, ignition and run-mode and protection features.

- › Integrated high performance PFC stage
- › Intelligent digital/mixed signal power control
- › Integrated high voltage half-bridge driver
- › All parameters set using only resistors
- › Highly accurate timing and frequency control over a wide temperature range
- › Different types for single, series and parallel lamps

Features

- › Able to handle lamp chokes with higher saturation behavior
- › Separate adjustable levels of lamp overload and rectifier effect detection
- › Adjustment of the preheat time
- › No high voltage capacitor required for detection of lamp removal (capacitive mode operation)
- › Automatically restarts by surge and inverter overcurrent events
- › Self-adapting dead time adjustment of the half-bridge driver

Benefits

- › Optimized lamp choke size
- › Dramatically reduced time for key tests such as end of life detection, preheat/ignition timeout and pre-run operation modes
- › Suitable for dimming and multi-power ballasts
- › Enables ballast compatibility with a wider range of lamp types
- › Flexible support of both current and voltage mode preheating
- › Reduced BOM costs
- › Intelligent distinguishing between surge and half-bridge overcurrent events
- › Meets standards for emergency lighting (according to DIN VDE 0108)
- › Eases design of multi-power ballasts and reduces EMI
- › Enhanced reliability of ballasts

Function	ICB2FL03G	ICB2FL02G	ICB2FL01G
Capacitive load protection	Activated	Deactivated	Activated
Suitable for dimming	✓	✓	✓
Max. adjustable run frequency	140 kHz	140 kHz	120 kHz
Package	SO-16 small body	SO-19 wide body	SO-19 wide body
Driver capability	650 V	900 V	900 V
Lamp connection	Single and series	Single, series and parallel	Single, series and parallel

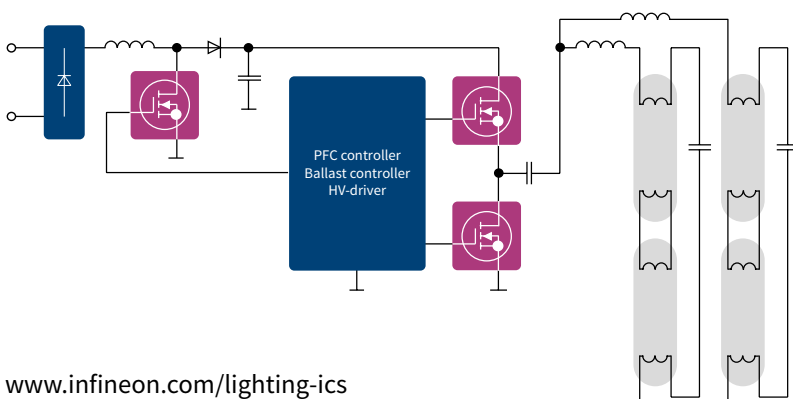

www.infineon.com/lighting-ics

Integrated point-of-load converters

Digital interface IPOL voltage regulators

The digital interface IPOL devices are easy-to-use, fully integrated and highly efficient DC-DC regulator offering I₂C/PMBus™, parallel VID, Intel SVID. The on-board PWM controller and MOSFETs make the family a space-efficient solution, providing accurate power delivery for low output voltage and high current applications.

The IR3806x family of PMBus™ enabled IR MOSFET™ IPOL based SupIRBuck™ voltage regulators offers:

- › Compactness of integrated controller, driver and MOSFETs
- › High performance analog voltage mode engine
- › Flexibility of a rich PMBus™ interface

The IR381(2/3)6x family features OptiMOS™ 5 for the highest efficiency and adds Intel SVID support (IR381(/3)6x) for Intel based systems or parallel VID (IR3826x) for voltage scaling or 8 programmable output voltages booting options to avoid programming at start up. Pin compatible options with and without PMBus™ are available to allow the flexibility of using PMBus™ only during evaluation or easily upgrade a system to PMBus™ without re-layout.

Main features

- › PMBus™ revision 1.2 compliant
- › ≥ 66 PMBus™ commands
- › Wide input voltage range and single 5 V – 16 V input operations
- › Differential remote sense
- › Ultralow jitter voltage mode engine
- › Operation temp: -40° to 125° C

Main benefits

- › Only single chip solution with extensive PMBus™, parallel VID, Intel SVID support allows 50 percent space saving versus external power competition
- › Intel SVID support for Intel-based systems
- › Parallel VID or PMBus™ for voltage setting and margining
- › Telemetry status via digital bus
- › Remote monitoring and update
- › Parameter changes by register
- › Flexible sequencing
- › High accuracy low ripple
- › Integrated sequencing, margin, current and voltage monitoring

Analog IPOL voltage regulators

High efficiency and accuracy: Our point-of-load converters integrate a PWM controller, driver and MOSFETs into a small PQFN package for ease-of-use. The patented PWM modulation scheme allows greater than 1 MHz switching frequencies to deliver ultra compact layouts and smallest bill-of-materials. It features wide operating temperature ranging from operating temperature from -40° to 125°C.

Main benefits

- › Enhanced voltage mode PWM devices offer high accuracy, ultralow ripple and noise and higher control bandwidth for less capacitors
- › Scalable solutions from 3 to 35 A
- › For designs requiring high density, low cost and easy design, the family includes a 3 A device with enhanced stability constant-on-time engine that does not require external compensation enabling easy designs and fast time to market

Integrated POL portfolio

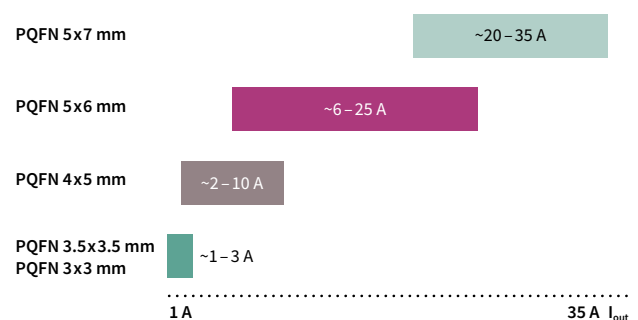

www.infineon.com/ipol

DC-DC IPOL portfolio

Digital interface IPOL

I ² C PMBus™, telemetry, margin, faults, SVID PVID Digital control/configuration, telemetry and diagnostic					
Part number	Max. current [A]	Package size [mm]	Max. V _{in}	Max. f _{sw}	Distinctive features
IR38064	35	5 x 7	21 V	1500 KHz	PMBus™
IR38063	25	5 x 7	21 V	1500 KHz	
IR38062	15	5 x 7	21 V	1500 KHz	
IR38060	6	5 x 6	16 V	1500 KHz	
IR38163	30	5 x 7	16 V	1500 KHz	OptiMOS™ 5, SVID + PMBus™
IR38165	30	5 x 7	16 V	1500 KHz	OptiMOS™ 5, SVID
IR38363	15	5 x 7	16 V	1500 KHz	OptiMOS™ 5, SVID + PMBus™
IR38365	15	5 x 7	16 V	1500 KHz	OptiMOS™ 5, SVID
IR38263	30	5 x 7	16 V	1500 KHz	OptiMOS™ 5, PVID + PMBus™
IR38265	30	5 x 7	16 V	1500 KHz	OptiMOS™ 5, PVID
IR38164	30	5 x 7	16 V	1500 KHz	OptiMOS™ 5, SVID + PMBus™, enhanced I _{mon}
IRPS5401	4+4+2+2+0.5	7 x 7	14 V	1500 KHz	5 output PMIC, PMBus™

Analog interface IPOL

„Performance“ voltage mode PWM Ultralow jitter and noise, high accuracy and low ripple					
Part number	Max. current [A]	Package size [mm]	Max. V _{in}	Max. f _{sw}	Distinctive features
IR3883	3	3 x 3	14 V	800 KHz	Constant-on-time
IR3823	3	3.5 x 3.5	21 V	1500 KHz	3 soft start
IR3897	4	4 x 5	21 V	1500 KHz	DDR tracking and analog voltage margin/AVSO
IR3898	6	4 x 5	21 V	1500 KHz	
IR3899	9	4 x 5	21 V	1500 KHz	
IR3894	12	5 x 6	21 V	1500 KHz	
IR3895	16	5 x 6	21 V	1500 KHz	OptiMOS™ 5, 3-level OCP
IR3826	23	5 x 6	17 V	1500 KHz	
IR3826A	16	5 x 6	17 V	1500 KHz	OptiMOS™ 5, 3-level OCP
IR3448	16	5 x 6	21 V	1500 KHz	True differential remote sensing for accuracy and thermally enhanced Cu clip package
IR3847	25	5 x 6	21 V	1500 KHz	
IR3846	35	5 x 7	21 V	1500 KHz	Dual output for density and out-of-phase for less input capacitor
IR3891	4+4	5 x 6	21 V	1500 KHz	
IR3892	6+6	5 x 6	21 V	1500 KHz	

Point-of-load products – how to choose

Analog voltage mode IPOL
3-35A

Flexibility/low jitter/low ripple/constant frequency operations
IR389x/IR384x/IR344x/IR3823

- Programmable f_{sw} up to 1.5 MHz
- Transient
- Tracking
- Remote sense

DC-DC products
1 to 35 A

PMBus™ digital IPOL

IPOL with digital interface

- Telemetry
- Margining
- Intel SVID Support
- Parallel VID
- IR3806x: 6-35 A with PMBus™
- IR3816x: 15 A, 30 A with PMBus™ and Intel SVID
- IR38263: 30 A with PVID and PMBus™

Digital mode: I2C/PMBus™ interface

PMBus™ IC capabilities

Inventory	Device ID
Configuration	On/off configuration fault/warnings
Control	Sequencing delay/ramp fault response
Telemetry	V _{out} , I _{out} , power temperature, peak values
Status	Comms, data, temps

Constant-on-time IPOL

Easy/light-load efficiency
IR3883: 3 A

- 50 mA light load efficiency = 75% (12 V_{in} → 1.2 V_{out})

www.infineon.com/ipol

www.infineon.com/analog-ipol

CAN transceivers

Proven quality for power management applications

Our CAN transceivers provide proven quality, reliable track records and high robustness in automation applications. They feature excellent electromagnetic performance and low levels of electromagnetic interference (EMI), and are designed for ISO compliance. While our IFX1050G, IFX1050GVIO and IFX1040SJ devices are optimized for high-speed CAN communication, the new IFX1051 transceiver family addresses the upcoming CAN FD (flexible data rate) markets beyond 1 Mbit/s.

Key features

- › Transmission rates up to 2 Mbit/s ISO11898 compliant
- › Low-power modes
- › Receive-only mode
- › Standby/sleep mode
- › Bus wake-up
- › Thermal protection
- › CAN FD compliance

Key benefits

- › Low current consumption
- › Thermal protection
- › Low power modes
- › Excellent EMI performance and EMI robustness
- › Standby/sleep mode
- › Pin-to-pin replacements for industry-standard parts

Product portfolio

Product number	Package	Transceiver type	ISO compliance	Transmission rate (max.)
IFX1050G	PG-DSO-8	High-speed CAN	ISO11898-2	1 Mbps
IFX1050GVIO	PG-DSO-8	High-speed CAN	ISO11898-2	1 Mbps
IFX1040SJ	PG-DSO-8	High-speed CAN	ISO11898-2, ISO11898-5	1 Mbps
IFX1051SJ	PG-DSO-8	CAN FD	ISO 11898-2	2 Mbps
IFX1051LE	PG-TSON-8	CAN FD	ISO 11898-2	2 Mbps

CAN FD transceiver

In addition to the classic CAN transceiver portfolio, Infineon is also offering a CAN FD transceiver. By using two reserved bits in the protocol, CAN FD will boost the baudrate of CAN systems. The so-called "bit-rate-switch" (BRS) bit increases the bit rate within the CAN data field from 1 to 2 Mbit/s whereas the so-called "extended-data-length" (EDL) bit increased "payload" from 8 bytes to 64 bytes resulting in higher bandwidth.

The Infineon CAN FD transceiver IFX1051, designed for HS CAN networks in industrial applications, acts as an interface between the physical bus layer and the CAN protocol controller - it drives the signals to the bus and protects the microcontroller against interferences generated within the network. Based on the high symmetry of the CANH and CANL signals, the IFX1051 provides a very low level of electromagnetic emission (EME) within a wide frequency range.

www.infineon.com/industrial-transceivers

IFX1051 key features

- > Fully compatible to ISO 11898-2
- > Wide common mode range for EMI
- > Very low EME
- > Excellent ESD robustness
- > Guaranteed loop delay symmetry to support CAN FD data frames up to 2 Mbit/s
- > VIO input for voltage adaption to the microcontroller supply
- > Extended supply range on V_{CC} and VIO supply
- > CAN short-circuit proof to ground, battery and V_{CC}
- > TxD time-out function with very long TxD timeout timing
- > Low CAN bus leakage current in power-down state
- > Overtemperature protection
- > Protected against transients
- > Receive-only mode
- > Green product (RoHS compliant)
- > Two package options: tiny package PG-TSON-8 or standard package PG-DSO-8

IFX1051 key benefits

- > Cost efficient replacement to industry market standard device *1051
- > High-speed communication up to 2 Mbit/s
- > Wide temperature range

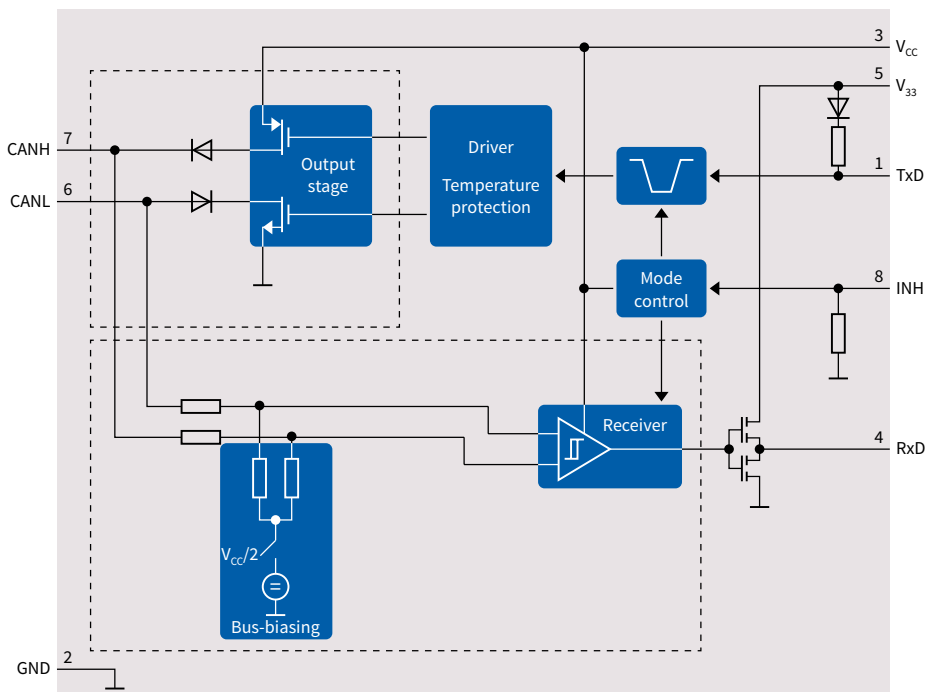
**CAN FD IFX1051 block diagram**

Voltage regulators

Energy-efficient voltage regulators and trackers

Our linear voltage regulators and trackers help to reduce energy consumption, extending operating time and minimizing operating costs across all kinds of systems. The wide supply voltage range, low quiescent current, rich protective feature set and choice of packages make our devices the perfect fit across a broad application spectrum, apart from automation systems as well for health care, traffic, power tools, lighting and many other multi-market systems. Our trackers are ideal as additional supplies for off-board loads to increase system reliability.

Key features

- › Input voltage up to 60 V
- › Output current up to 1.5 A
- › Output voltage adjustable or fixed to specific values
- › Quiescent current down to 5 μ A
- › Overload, overtemperature, short circuit and reverse-polarity protection
- › Low current consumption
- › Extended temperature range -40°C ... +125°C

Key benefits

- › Pin-to-pin compatibility with industry-standard parts
- › Very low dropout voltage
- › Trackers for optimized heat distribution and external protection
- › Trackers for maximum system cost reduction
- › Small robust packages

Infinion's microcontroller families and industrial voltage regulators

Microcontroller family	Input voltage [V]	Input current (max.) [mA]	Voltage regulator
XMC1000 family	1.8 ... 5.5	<100	IFX54211/IFX2931/IFX4949/IFX25001/IFX544xx/ IFX30081
XMC4000 family	3.3	<500/300	IFX1763/IFX544xx/IFX1117/IFX30081
XC8xx	3.3 ... 5.0	200	IFX20001/IFX30081/IFX21401/IFX4949/IFX544xx
XE166/XC2000	1.5 and 3.3 or 5.0	100	IFX25401/IFX24401/IFX2931/IFX4949/IFX1763/IFX54441
TriCore™	1.5 ... 3.3	>400	IFX27001/IFX8117/IFX91041/IFX80471/IFX25001/IFX1117

Industrial linear voltage regulator (selection tree)

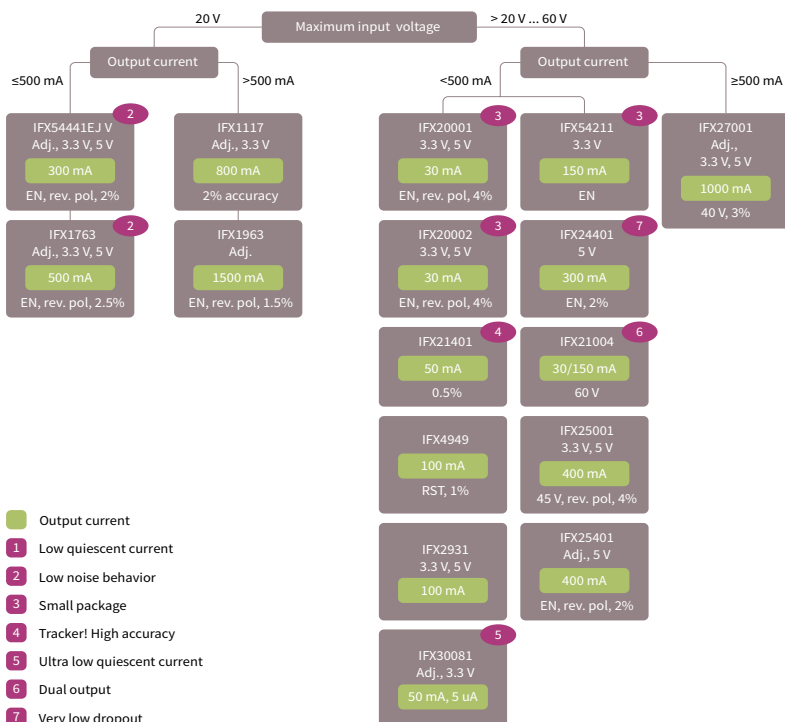

www.infineon.com/industrial-voltage-regulators

DC-DC converters

Robust range of converters for the widest application spectrum

Our high-efficiency switching regulators and controllers help to reduce energy consumption. In addition to extending the operating time of battery powered systems, they also significantly improve the thermal budget of the application. Overall, this translates into minimal operating costs. For your design flexibility, they are available as adjustable voltage variants as well as with dedicated fixed output voltage values.

Key features

- > Input voltage up to 60 V
- > Output currents going from 500 mA up to 10 A
- > Switching frequencies ranging from 100 kHz to 2.2 MHz
- > Shutdown quiescent current down to below 2 μ A
- > Current limitation and overtemperature protection
- > Enable feature

Key benefits

- > High-efficiency regulation
- > Only a few external components needed for stable regulation
- > Perfectly suited for regulation in pre-/post-regulation power supply architectures

DC-DC converters

Part number	V _o (multiple)	Output current type	Output current [A]	Product features	Package
IFX81481ELV	Adjustable	Buck controller	10.0	10 A synchronous DC-DC adjustable step down controller; f = 100 kHz-700 kHz, N	PG-SSOP-14
IFX90121EL V50	5.0 V	Buck converter	0.5	V _{in} up to 45 V, 2.2 MHz step-down regulator with low quiescent current	PG-SSOP-14
IFX80471SK V	Adjustable	Buck controller	2.3	V _{in} up to 60 V; V _o adjustable from 1.25 V up to 15 V; external MOSFET	PG-DSO-14
IFX80471SK V50	5.0 V	Buck controller	2.3	V _{in} up to 60 V; external MOSFET	PG-DSO-14
IFX91041EJV	Adjustable	Buck converter	1.8	V _o adjustable from 0.6 V up to 16 V; tolerance 2% up to 1000 mA	PG-DSO-8
IFX91041EJ V33	3.3 V	Buck converter	1.8	V _o fixed to 3.3 V; tolerance 2% up to 1000 mA	PG-DSO-8
IFX91041EJ V50	5.0 V	Buck converter	1.8	V _o fixed to 5.0 V; tolerance 2% up to 1000 mA	PG-DSO-8

IFX91041 block diagram

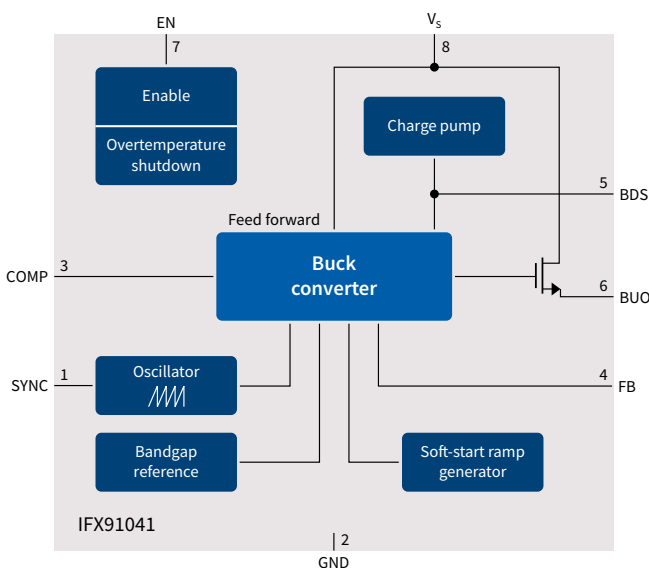

Industrial DC-DC buck regulators (selection tree)

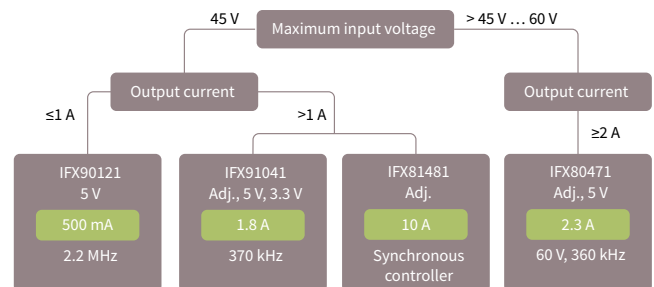

www.infineon.com/industrial-dcdc-converters

ISOFACE™

Galvanic isolated high-side switches and input ICs

Our ISOFACE™ product family provides robust and intelligent galvanic isolation for industrial control applications such as programmable logic controllers, sensor input modules, control panels and general control equipment. The output switches are compact in design, enabling robust and reliable operation at low system cost. Ideal for high-speed applications, input ICs are equally robust, reliable and compact – also offering superior EMI robustness and diagnostics.

Isolated output switches



Key features

- > Integrated galvanic isolation (500 V)
- > Eight channels (0.6 or 1.2 A, each)
- > Inductive load switching
- > Diagnostic feedback (overtemperature, overload)
- > Serial and parallel MCU interface

Key benefits

- > Robust and reliable
- > Compact system solution
- > Lower system cost
- > System status feedback
- > Directly interfacing with all MPUs and MCUs

Isolated output switch block diagram

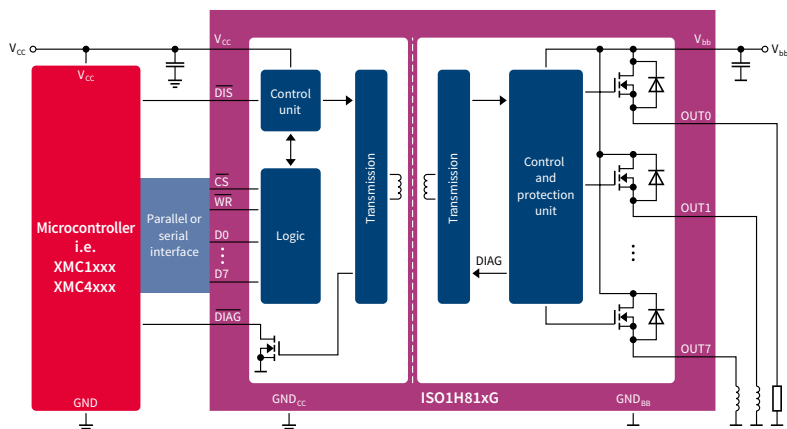

Product overview		ISO1H801G	ISO1H811G	ISO1H812G	ISO1H815G	ISO1H816G
Switch	V _{bb} operational range: 11 V to 35 V	✓	✓	✓	✓	✓
	Max. continuous load current per channel	0.6 A	0.6 A	0.6 A	1.2 A	1.2 A
	Load current increase by using outputs in parallel	✓	✓	✓	✓	✓
	Inductive clamping energy per channel: 1 Joule	✓	✓	✓	✓	✓
Microcontroller interface	Type	Parallel	Parallel	Serial	Parallel	Serial
	Nominal voltages	5 V	3.3 V/5 V	3.3 V/5 V	3.3 V/5 V	3.3 V/5 V
Safety features	Isolation voltage: V _{ISO} = 500 V UL508 and EN 61131-2 certified	✓	✓	✓	✓	✓
	Active current limitation	✓	✓	✓	✓	✓
	Thermal shutdown	✓	✓	✓	✓	✓
	Common output disable pin	✓	✓	✓	✓	✓
Diagnostics feedback	Overtemperature		✓	✓	✓	✓
	V _{bb} undervoltage		✓	✓	✓	✓
Package DSO-36 (16x14 mm)		✓	✓	✓	✓	✓
Infineon ordering code		SP000722122	SP000413798	SP000413800	SP000555576	SP000555578

www.infineon.com/isoface

Isolated digital input ICs



Key features

- > Integrated galvanic isolation (500 V)
- > Eight channels (IEC type 1/2/3)
- > Up to 500 kHz sampling speed
- > Programmable input filters
- > Channel-specific diagnostics (wire-break, undervoltage)

Key benefits

- > Robust and reliable
- > Compact system solution
- > High-speed applications
- > Superior EMI robustness
- > System status feedback
- > Valuable maintenance support

Digital input switch block diagram

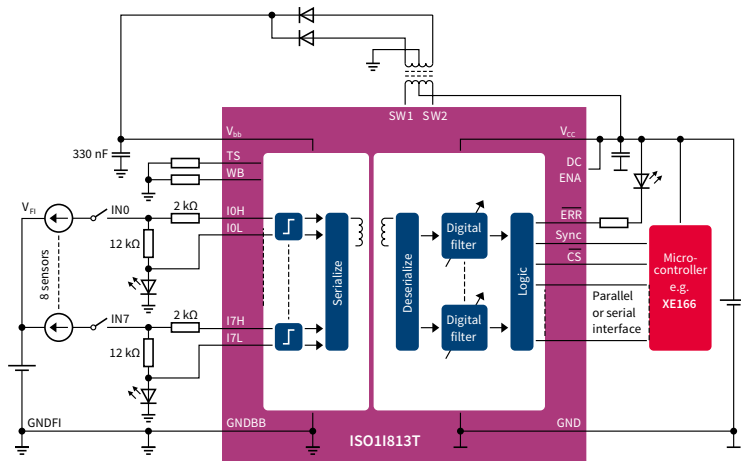

XMC4800 automation board V2

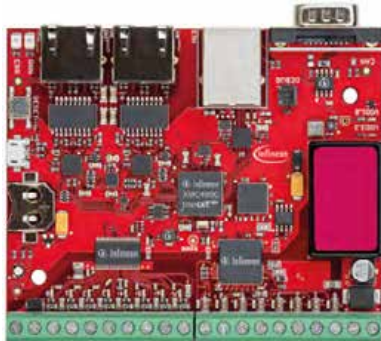

The automation board utilizes Infineon's industry-leading XMC™ ARM® Cortex®-M4 microcontroller in combination with Infineon supply, interface, communication and safety products.

- > Complete automation kit gateway
- > Combined MCU with EtherCAT® slave application
- > Isolated interfaces w/ diagnose
- > Ethernet connectivity with software examples available
- > 24 V supply
- > CAN connectivity
- > Full software DAVE™ examples

Ordering code: SP001632038

Product overview		ISO11811T	ISO11813T
Input characteristics	IEC type: I, II, III	✓	✓
	Input status LED	✓	✓
	Max. sampling frequency	125 kHz	500 kHz
	Deglitching filter setting	Hard wired	Software, individual per channel
	Synchronous data acquisition	-	✓
µC interface	3.3 V/5 V	✓	✓
	Serial and parallel	✓	✓
Safety features	500 V isolation voltage	✓	✓
	Wire break, channel-specific	-	✓
	V _{bb} undervoltage	-	✓
Support for external V _{bb} supply	-	-	✓
Package TSSOP-48 (8x12.5 mm)	✓	✓	✓
Infineon ordering code		SP000876494	SP000876504

www.infineon.com/isoface

Industrial PROFET™

Protected high-side switches

The well-established high-side switch Industrial PROFET™ products were designed for targeting a variety of industrial applications which include all types of resistive, inductive and capacitive loads. Due to their outstanding energy robustness, they are perfectly suitable for switching even higher inductive loads and driving relays. Their main application areas include high-voltage applications (VBAT up to 60 V), high-speed PWM applications (up to 1 kHz) and they are most notably capable of switching higher inductances smoothly. Industrial PROFET™ can be applied to drive any kind of sensor units, indicators, displays, LEDs, relays, valves and magnetic actuators or replace electromechanical relays, fuses and discrete circuits. Industrial PROFET™ are also the perfect match for applications with long wiring or any other kind of inductive loads or applications with space constraints.

Key applications

- › Industrial automation
- › Programmable logic controller (PLC)
- › Digital I/O modules
- › Robotics
- › Building and home automation
- › Set Home
- › Solar applications
- › Wind energy systems
- › Smart grid
- › Medical
- › E-bikes and LEVs (light electric vehicles)
- › Motor control and drives
- › Power supplies

Industrial automation system diagram

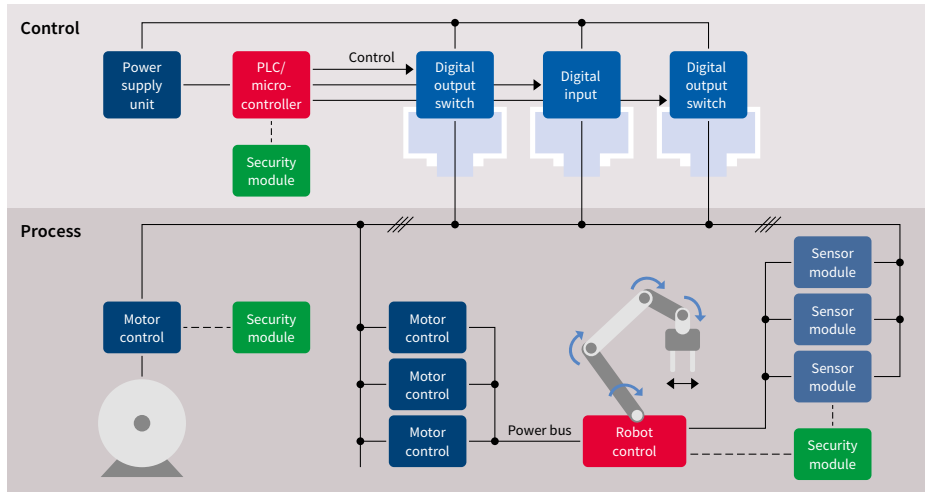

System benefits

- › Right fit for digital output switches, motor or robot control, protected switching of decentralized loads like sensors or auxiliary supply
- › Suitable for all types of complex loads including high inductances (high EAS)
- › Outstanding robustness and reliability as required by industrial mission profiles
- › Thermally optimized products with low $R_{DS(on)}$ to deal with the high ambient temperatures and limited or even no cooling
- › Diagnosis and protection for safe system operation
- › Small and compact design for higher integration and applications with space constraints

PLC – programmable logic controller digital output modules

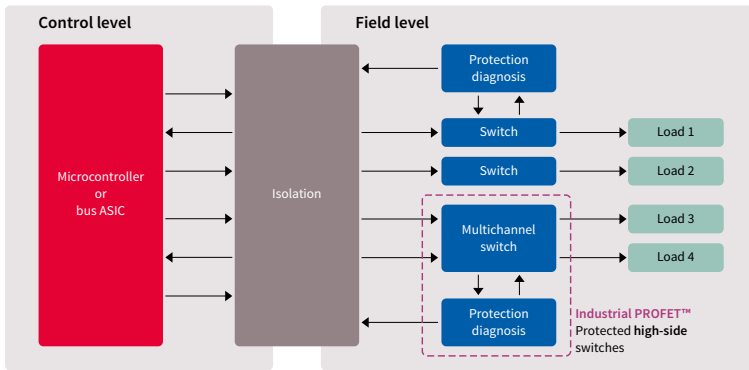

System benefits

- › Suitable for all types of complex loads including high inductances (EAS) as PLC manufacturers cannot predict how the end customer will use the digital outputs
- › Outstanding robustness and reliability as required by industrial mission profiles
- › Thermally optimized products with low $R_{DS(on)}$ to deal with the high ambient temperatures within I/O modules with limited or even no cooling
- › Diagnosis and protection for safe system operation
- › Small and compact design for higher integration
- › Addressing the I/O modules quasi standard currents 2 A & 0.5 A, but also lower currents as within micro-PLCs

Product	Number of channels	$R_{DS(on)}$ (typ) [mΩ]	Nominal load current [A]	E_{AS} [mJ]	Recommended operating voltage range [V]	$I_{L(SC)}$ (typ) [A]	Diagnosis	Package
ITS4060S-SJ-N	1	50	3.10	900 @ 1.50 A	5.00 ... 34.00	17.0	n/a	DSO-8
ISP772T	1	50	2.60	900 @ 1.50 A	5.00 ... 34.00	17.0	n/a	DSO-8
ITS428L2	1	60	7.00	190 @ 7.00 A	4.75 ... 41.00	22.0	Digital	TO252-5
ITS4100S-SJ-N	1	70	2.40	870 @ 1.00 A	5.00 ... 34.00	10.0	n/a	PG-DSO-8
ISP762T	1	70	2.00	870 @ 1.00 A	5.00 ... 34.00	10.0	n/a	DSO-8
ITS4200S-ME-O	1	150	1.10	700 @ 0.50 A	11.00 ... 45.00	1.4	n/a	SOT-223-4
ITS4141N	1	150	1.10	700 @ 0.50 A	12.00 ... 45.00	1.4	n/a	SOT-223-4
ITS4141D	1	150	1.10	12,000 @ 0.50 A	12.00 ... 45.00	1.4	n/a	TO-252-5
ITS4200S-ME-P	1	150	2.20	160 @ 1.00 A	11.00 ... 45.00	3.0	n/a	SOT-223-4
ITS4142N	1	150	2.20	160 @ 1.00 A	12.00 ... 45.00	3.0	n/a	SOT-223-4
ITS4200S-ME-N	1	160	1.20	500 @ 0.50 A	5.00 ... 34.00	1.5	n/a	DSO-8
ISP452	1	160	1.20	500 @ 0.50 A	5.00 ... 34.00	1.5	n/a	SOT-223-4
ITS4200S-SJ-D	1	150	1.70	125 @ 1.00 A	6.00 ... 52.00	6.5	Digital	DSO-8
ISP752R	1	200	1.70	125 @ 1.00 A	6.00 ... 52.00	6.5	Digital	DSO-8
ISP752T	1	200	1.70	125 @ 1.00 A	6.00 ... 52.00	6.5	n/a	DSO-8
ITS4300S-SJ-D	1	250	0.80	800 @ 0.30 A	5.00 ... 34.00	1.2	Digital	DSO-8
ISP742RI	1	350	0.80	800 @ 0.30 A	5.00 ... 34.00	1.2	Digital, inverted	DSO-8
ITS41K0S-ME-N	1	1000	0.55	1000 @ 0.15 A	4.90 ... 60.00	0.9	n/a	SOT-223-4
ITS4140N	1	1000	0.55	1000 @ 0.15 A	4.90 ... 60.00	0.9	n/a	SOT-223-4
ITS4040D-EP-D	2	40	2 x 2.00	185*	5.00 ... 45.00	4.1	Digital	TSDSO-14
ITS5215L	2	90	2 x 2.00	178 @ 3.50 A	5.50 ... 40.00	15.0	Digital	DSO-12
ITS42K5D-LD-F	2	2500	2 x 0.25	Freewheeling	4.50 ... 45.00	0.6	Digital	TSO-N-10
ITS4075Q-EP-D	4	75	4 x 2.00	60*	5.00 ... 45.00	4.1	Digital	TSDSO-14
ITS4090Q-EP-D	4	100	4 x 0.50	410*	5.00 ... 45.00	1.5	Digital	TSDSO-14
ITS724G	4	90	4 x 2.00	120 @ 3.30 A	5.50 ... 40.00	15.0	Digital	DSO-20
ITS4130Q-EP-D	4	130	4 x 0.50	380*	5.00 ... 45.00	1.25	Digital	TSDSO-14
ITS716G	4	140	4 x 1.00	76 @ 2.30 A	5.50 ... 40.00	9.0	Digital	DSO-20
ITS711L1	4	200	4 x 1.00	150 @ 1.90 A	5.00 ... 35.00	7.5	Digital	DSO-20
ITS42008-SB-D	8	200	8 x 0.60	10,000 @ 625 mA	11.00 ... 45.00	3.0	Digital	DSO-36
ITS4880R	8	200	8 x 0.60	10,000 @ 625 mA	11.00 ... 45.00	3.0	Digital	DSO-36

Industrial PROFET™ evaluation board plus samples:

- › ITS4060S-SJ-N, ITS4100S-SJ-N, ITS4200S-SJ-D, ITS4300S-SJ-D, ITS4200S-ME-N, ITS4200S-ME-O, ITS4200S-ME-P, ITS41K0S-ME-N
order: INDPROFETEVALBOARDTOB01

Additional evaluation boards:

- › ITS42008, order: DEMOBOARDITS42008TOB01
- › ITS42K5D-LD-F, order: DEMOBOARDITS42K5DTOB01
- › ITS 4040D-EP-D, order: DEMO BOARD ITS 4040DTOB01
- › ITS 4075Q-EP-D, order: DEMO BOARD ITS 4075QTOB01
- › ITS 4090Q-EP-O, order: DEMO BOARD ITS 4090QTOB01
- › ITS 4130Q-EP-D, order: DEMO BOARD ITS 4130QTOB01

www.infineon.com/industrial-profet

* Per one channel

HITFET™

Protected low-side switches

HITFET™ stands for highly-integrated temperature-protected MOSFET. These well-established low-side switches offer a compelling feature set with protection against overtemperature, short circuit and overload conditions as well as ESD robustness. The HITFET™+ family is the new generation based on a new technology, enabling a significant shrink compared to the existing HITFET™ portfolio (up to 50 percent shrink). This new generation consists of standard and fully-featured protected low-side switches (35 to 125 mΩ) in the TO-252-3 DPAK/TO-252-5 DPAK and TDSO-8 packages. HITFET™ and HITFET™+ devices address a wide range of applications including resistive, inductive and resistive loads.

Key features

- › Low-side switches with integrated protection features
- › Scalable in $R_{DS(on)}$ ranges from 490 mΩ down to 11 mΩ
- › Adjustable slew rate control (BTFxxx)
- › Thermal shutdown with auto restart or latch behavior
- › Status feedback via
 - Increased input current (HITFET™ 2nd gen.)
 - Digital read out via SRP (BTF3050TE)
 - Via status pin (BTF3xxxEJ)

Key applications

- › Industrial automation*
- › Programmable logic controller (PLC)**
- › Digital I/O modules
- › Building and home management
- › All kind of solenoid or valve driving
- › Power modules
- › Solar power inverters

Key benefits

- › High design flexibility with scalable $R_{DS(on)}$ and package
- › Driving applications with high switching speed requirements up to 25 kHz (e.g. valve, solenoid)
- › Easy to design-in
- › Choice of packages to match individual application needs

Application diagram example for HITFET™

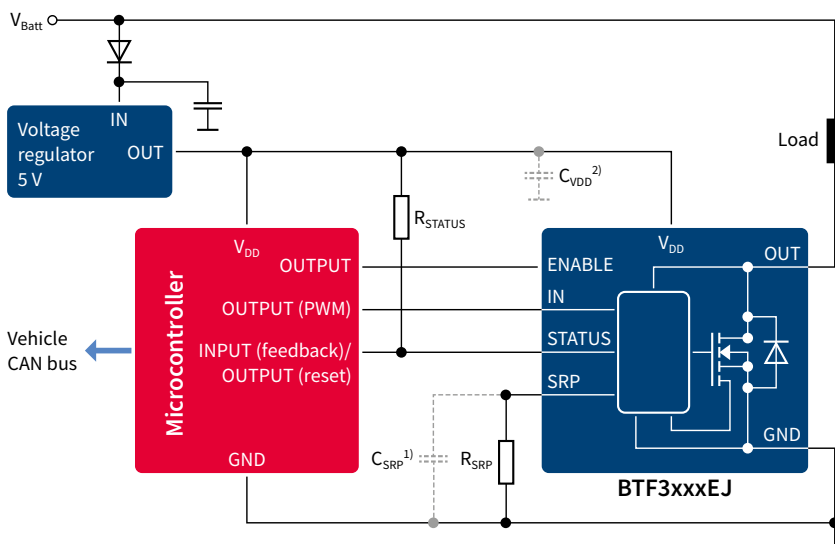

1) $C_{SRP-GND} < 100$ pF – maximum permitted parasitic capacitance at the SRP-pin
 2) Filter capacitor on supply, recommended 100 nF

www.infineon.com/hitfet

*See block diagram on page 204
 ** See block diagram on page 205

Product type	Product family	Channels	$R_{DS(on)}$ @ 25°C [mΩ]	Nominal load current [A]	EAS [mJ]	Operating voltage range [V]	$I_{L(SD)}$ (typ) [A]	$I_{L(lim)}$ (typ) [A]	$I_{L(lim), TRIGGER}$ (typ) [A]	Diagnosis	Package
BTS3011TE NEW!	HITFET™+	1	10.7	10	300 @ 5 A	up to 28	-	35	70	Status pin	TO-252-5 (DPAK 5-leg)
BTS3035EJ	HITFET™+	1	28	5.00	105 @ 5 A	up to 31	-	20.00	-	Status pin	TDSO-8
BTS3035TF	HITFET™+	1	30	5.00	106 @ 5 A	up to 31	-	20.00	-	-	TO-252-3 (DPAK 3-leg)
BTF3035EJ* NEW!	HITFET™+	1	28	5.00	95 @ 5 A	up to 32	-	14.00	41.00	Status pin	TDSO-8
BTF3050TE	HITFET™+	1	40	3.00	120 @ 3 A	up to 28	-	8.00	30.00	Through SRP pin	TO-252-5 (DPAK 5-leg)
BTS3050EJ	HITFET™+	1	40	4.00	62 @ 3 A	up to 31	-	15.00	-	Status pin	TDSO-8
BTS3050TF	HITFET™+	1	44	4.00	64 @ 4 A	up to 31	-	15.00	-	-	TO-252-3 (DPAK 3-leg)
BTF3050EJ* NEW!	HITFET™+	1	40	4.00	62 @ 4 A	up to 32	-	10.00	29.00	Status pin	TDSO-8
BTS3060TF	HITFET™+	1	50	3.00	55 @ 3 A	up to 35	-	10.50	-	-	TO-252-3 (DPAK 3-leg)
BTS3080EJ	HITFET™+	1	64	3.00	35 @ 3 A	up to 31	-	10.00	-	Status pin	TDSO-8
BTS3080TF	HITFET™+	1	69	3.00	38 @ 3 A	up to 31	-	10.00	-	-	TO-252-3 (DPAK 3-leg)
BTF3080EJ* NEW!	HITFET™+	1	64	3.00	33 @ 3 A	up to 32	-	7.00	18.00	Status pin	TDSO-8
BTS3125EJ	HITFET™+	1	100	2.00	30 @ 2 A	up to 31	-	7.00	-	Status pin	TDSO-8
BTS3125TF	HITFET™+	1	108	2.00	24 @ 2 A	up to 31	-	7.00	-	-	TO-252-3 (DPAK 3-leg)
BTF3125EJ* NEW!	HITFET™+	1	100	2.00	23 @ 2 A	up to 32	-	5.00	12.00	Status pin	TDSO-8
BTS3018TC	HITFET™	1	14	6.00	1900	up to 36	-	30.00	-	Through input pin	TO-263-3-2 (TO-220-3 (SMD))
BTS141TC	HITFET™	1	25	5.10	4000	up to 36	-	25.00	-	Through input pin	TO-263-3-2 (TO-220-3 (SMD))
BTS3028SDL	HITFET™	1	28	5.00	350	up to 36	-	18.00	-	Through input pin	TO-252-3 (DPAK 3-leg)
BTS3028SDR	HITFET™	1	28	5.00	350	up to 36	-	18.00	-	Through input pin	TO-252-3 (DPAK 3-leg)
BTS133TC	HITFET™	1	40	3.80	2000	up to 36	-	21.00	-	Through input pin	TO-263-3-2 (TO-220-3 (SMD))
BTS3046SDL	HITFET™	1	46	3.60	140	up to 36	-	10.00	-	Through input pin	TO-252-3 (DPAK 3-leg)
BTS3046SDR	HITFET™	1	46	3.60	140	up to 36	-	10.00	-	Through input pin	TO-252-3 (DPAK 3-leg)
BTS117TC	HITFET™	1	80	3.50	1000	up to 36	-	7.00	-	Through input pin	TO-263-3-2 (TO-220-3 (SMD))
BTS3104SDL	HITFET™	1	104	2.00	50	up to 36	-	6.00	-	Through input pin	TO-252-3 (DPAK 3-leg)
BTS3104SDR	HITFET™	1	104	2.00	50	up to 36	-	6.00	-	Through input pin	TO-252-3 (DPAK 3-leg)
AUIPS2041L	HITFET™	1	100	1.40	-	up to 35	5.00	-	-	-	SOT-223
AUIPS2051L	HITFET™	1	250	0.90	-	up to 35	1.80	-	-	-	SOT-223
AUIPS2052G	HITFET™	2	250	0.90	-	up to 35	1.80	-	-	-	SO-8 (DSO-8)
BTS3408G	HITFET™	2	480	0.55	800	up to 36	-	1.00	-	Through input pin	DSO-8
BSP75N	HITFET™	1	490	0.70	550	up to 36	-	1.00	-	Through input pin	SOT-223

Low-side switch shield with BTF3050TE

The low-side switch shield from Infineon consists out of three BTF3050TE low-side switches of the HITFET™+ family providing three independent power channels that can be controlled via the input pins. The shield is compatible with microcontroller boards using the Arduino form factor, for example the corresponding ARM® powered XMC™ microcontroller kits from Infineon and supports fast and easy prototyping of applications with BTF3050TE.

Key features

- › PWM up to 14 kHz (10 percent duty cycle)
- › Driver circuit with logic level inputs
- › Fault feedback
- › Protection e.g. against overtemperature and overcurrent
- › Able to switch all kinds of resistive, inductive and capacitive loads

Operating conditions

- › Nominal voltage range 8 V – 18 V
- › Nominal current 3 A (typ.) DC



www.infineon.com/hitfet

www.infineon.com/shields-for-arduino

* Available in Q2 2018

Half- and H-bridges

Motor control design made easy

Half-bridges

The NovalithIC™ provides a complete, low-ohmic protected half-bridge in a single package (typ. path resistance at 25°C down to 10 mΩ). It can also be combined with an additional NovalithIC™ to create a H-bridge or three-phase bridge. The NovalithIC™ family has the capability to switch high-frequency PWM while providing overcurrent, overvoltage and overtemperature protection. The NovalithIC™ family offers cost-optimized, scalable solutions for protected high-current PWM motor drives with very restrictive board space. Due to the P-channel high-side switch the need for a charge pump is eliminated thus minimizing EMI. The latest addition to the NovalithIC™ family is the IFX007T, which is optimized for industrial applications.

Basic features

- > Low quiescent current
- > Capable for high PWM frequency
- > Logic level input
- > Adjustable slew rate
- > Cross-current protection

Protection features

- > Overtemperature shutdown
- > Overvoltage (lockout or smart clamp)
- > Undervoltage
- > Overcurrent

Diagnostic features

- > Overtemperature
- > Overvoltage
- > Overcurrent
- > Current sense and status

Product number	Operating range [V]	R _{DS(on)} path (typ.) [mΩ]	I _{D(tot)} (typ.) [A]	I _a (typ.) [μA]	Switch time (typ.) [μs]	Diagnosis	Protection	Package	Qualification
IFX007T	5.5 ... 40.0	10.0	70	7	0.25	OT, OC, CS	UV, OT, OC	PG-TO-263-7	JESD471

Application example for high-current PWM motor drives

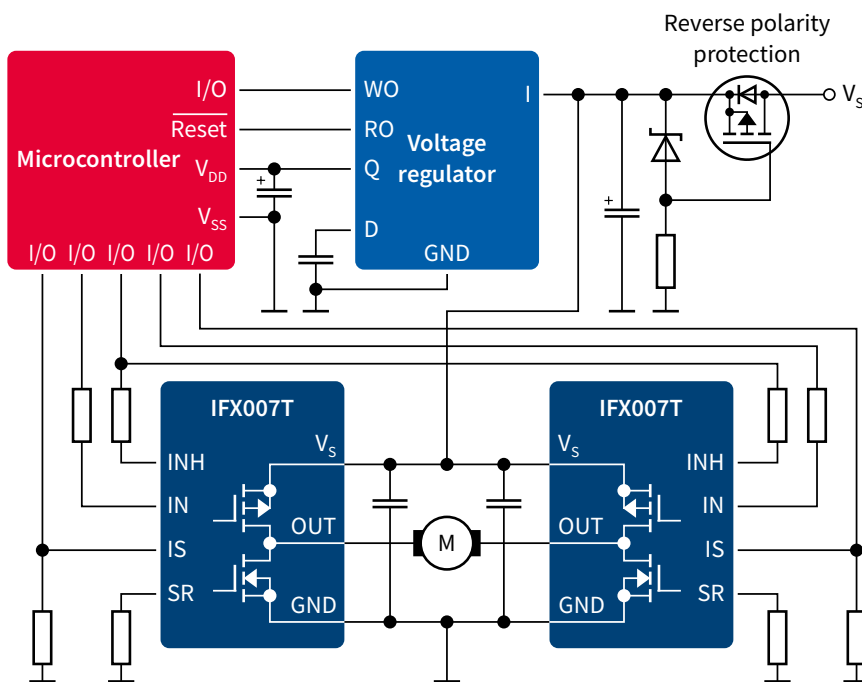

www.infineon.com/novalithic

CS = Current sense OC = Overcurrent OT = Overtemperature

Integrated multi-half-bridge driver ICs

The TLE94xyz are protected half-bridge drivers designed for 12 V motion control applications such as small DC motors for heating, ventilation and air conditioning (HVAC), as well as automotive mirror adjustment and fold. The family offers three-, four-, six-, eight-, ten-, and twelve-fold integrated half-bridge driver. All devices can drive DC motor loads up to 0.9 A per output in cascaded or parallel operation. They provide diagnosis of short circuit, open load, power supply failure and overtemperature for each half-bridge to ensure safe operation in HVAC or other systems. The TLE94xyz offers enhanced EMC performance, which in combination with the low quiescent current and a small package makes the product attractive for a wide range of 12 V automotive and industrial applications.

Key features and benefits

- › Three-, four-, six-, eight-, ten-, and twelve-fold half-bridges with integrated output stages and PWM
- › 16-bit SPI or direct inputs for control and diagnosis
- › Voltage supply range: 5.5– 20 V
- › Adjustable open load threshold for two outputs
- › Variable driving schemes for up to 11 motors
- › OUT 1 and 2 optimized for driving HS loads (e.g. LED)

Key applications

- › 12 V automotive and industrial applications
- › Flap motors in HVAC systems
- › Mirror adjustment and fold
- › Small DC motors (≤ 0.9 A/output)
- › Bi-stable relays

Block diagram TLE94112EL

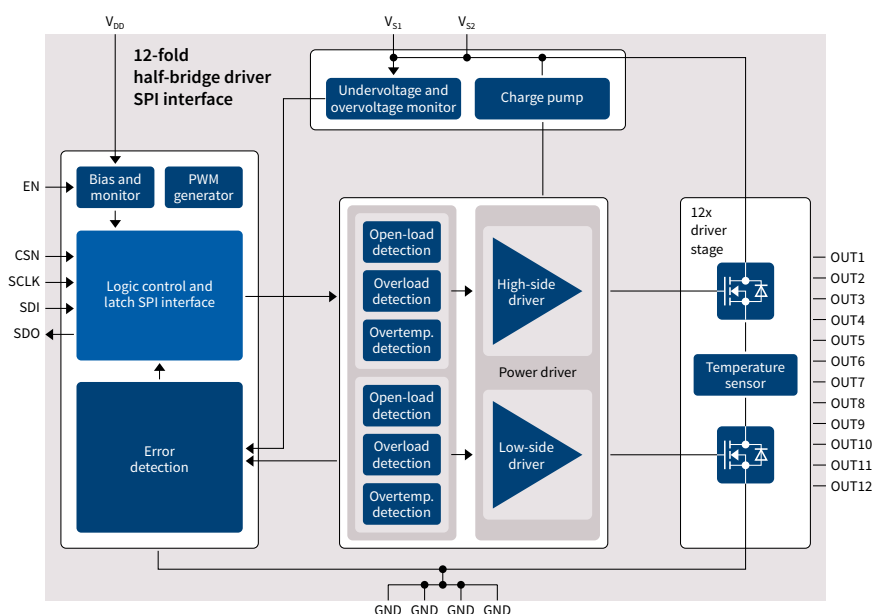

Product name	Configuration	$I_{L(NOM)}$ [A]	$I_{L(lim)}$ [A]	I_q [μ A]	$V_{S(OP)}$ [V]	Protection	Diagnostic interface	Highlights	$V_{CE(sat)}/R_{DS(on)}$	Package
TLE94003EP	3 x half-bridge	3 x 0.30	3 x 0.90	0.6	5.5...20	OC, OT, VS, UV/OV	Error flag	TLE94xyz family concept + small package	850 m Ω /switch	TSDSO-14-EP
TLE94103EP	3 x half-bridge	3 x 0.30	3 x 0.90	0.6	5.5...20	OC, OT, OL, VS, UV/OV	16-bit SPI	TLE94xyz family concept + small package	850 m Ω /switch	TSDSO-14-EP
TLE94004EP	4 x half-bridge	4 x 0.30	4 x 0.90	0.6	5.5...20	OC, OT, VS, UV/OV	Error flag	TLE94xyz family concept + small package	850 m Ω /switch	TSDSO-14-EP
TLE94104EP	4 x half-bridge	4 x 0.30	4 x 0.90	0.6	5.5...20	OC, OT, OL, VS, UV/OV	16-bit SPI	TLE94xyz family concept + small package	850 m Ω /switch	TSDSO-14-EP
TLE94106EL	6 x half-bridge	6 x 0.30	6 x 0.90	0.6	5.5...20	OC, OT, OL, VS, UV/OV	16-bit SPI	TLE94xyz family concept + backwards compatible to TLE84106EL	850 m Ω /switch	SSOP-24
TLE94108EL	8 x half-bridge	8 x 0.30	8 x 0.90	0.6	5.5...20	OC, OT, OL, VS, UV/OV	16-bit SPI	TLE94xyz family concept	850 m Ω /switch	SSOP-24
TLE94110EL	10 x half-bridge	10 x 0.30	10 x 0.90	0.6	5.5...20	OC, OT, OL, VS, UV/OV	16-bit SPI	TLE94xyz family concept + backwards compatible to TLE84106EL	850 m Ω /switch	SSOP-24
TLE94112EL	12 x half-bridge	12 x 0.30	12 x 0.90	0.6	5.5...20	OC, OT, OL, VS, UV/OV	16-bit SPI	TLE94xyz family concept + 12 outputs in one package	850 m Ω /switch	SSOP-24

DC motor control shield with IFX007T for Arduino

The DC motor control shield is capable of driving two uni-directional DC motors (half-bridge configuration) or one bidirectional DC motor (H-bridge configuration). The implemented half-bridge NovalithIC™ IFX007T can be controlled by a PWM via the IN pin. Interfacing to a microcontroller is made easy by the integrated driver IC which features logic level inputs, diagnosis with current sense, slew rate adjustment, dead time generation and protection against overtemperature, undervoltage, overcurrent and short circuit.

Features

- › Capable of high frequency PWM, e.g. 30 kHz
- › Adjustable slew rates for optimized EMI by changing external resistor
- › Driver circuit with logic level inputs
- › Diagnosis with current sense

Target applications

- › Brushed DC motor control up to 250 W continuous load
- › 24 V nominal input voltage (max. 6 V–40 V)
- › Average motor current 30 A restricted due to PCB (IFX007T current limitation @ 55 A min.)

DC motor control with half-bridge IFX007T

Infineon's shields for Arduino are compatible with microcontroller boards using the Arduino-compatible form factor, e.g. Infineon's XMC™ microcontroller kits.

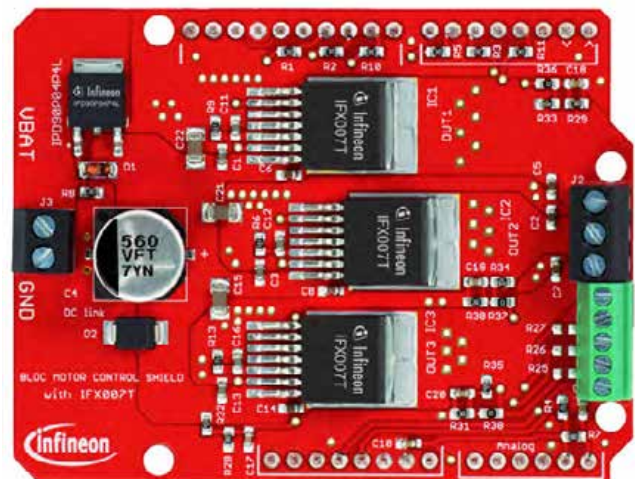

DC motor shield with TLE94112EL for Arduino

The DC motor shield is a small evaluation board equipped with TLE94112EL for use with Arduino. The TLE94112EL is capable to drive up to 6 small DC motors in parallel mode or up to 11 DC motors in cascaded mode. All outputs can drive up to 0.9 A. The outputs can be used stand-alone or combined to increase driving capability up to 3.6 A.

Features

- › Driver with 12 half-bridge outputs to drive DC motors, resistive or inductive loads
- › Driver is protected against overtemperature, overcurrent, overvoltage, undervoltage and enables diagnosis of overcurrent, overvoltage, undervoltage
- › SPI interface with zero clock diagnosis
- › Enhanced EMC performance
- › Integrated PWM generator with three different frequencies (80 Hz, 100 Hz, 200 Hz)

Target applications

- › Multi-motor applications
- › DC motors and voltage controlled bipolar stepper motors
- › Toys
- › HVAC systems

www.infineon.com/shields-for-arduino
www.infineon.com/makers

Integrated H-bridges

IFX9201SG and IFX9202ED* are general purpose 6 A H-bridges designed for the control of small DC motors and inductive loads. The outputs can be pulse width modulated at frequencies up to 20 kHz, which enables operation above the human sonic range by means of PWM/DIR control. While the signal at the DIR input defines the direction of the DC motor, the PWM signal controls the duty cycle. For load currents above the current limitation threshold (8 A typically), the H-bridges switch into chopper current limitation mode.

Key features and benefits

- > Up to nominal 36 V supply voltage
- > Short circuit, overtemperature protection and undervoltage shutdown
- > Detailed SPI diagnosis or simple error flag
- > Simple design with few external components
- > Small and robust DSO-12-17 (IFX9201SG) and DSO-36-72 (IFX9202ED) packages



Product number	Current limit (min.) [A]	Quiescent current (typ.) [μ A]	Operating range [V]	$R_{DS(on)}$ (typ./switch) [m Ω]	Package	$R_{th(jc)}$ (max.) [K/W]
IFX9202SG	2 x 6.0 A	19.0	5...36	2 x 100	DSO-36	2 x 0.5

Applications examples

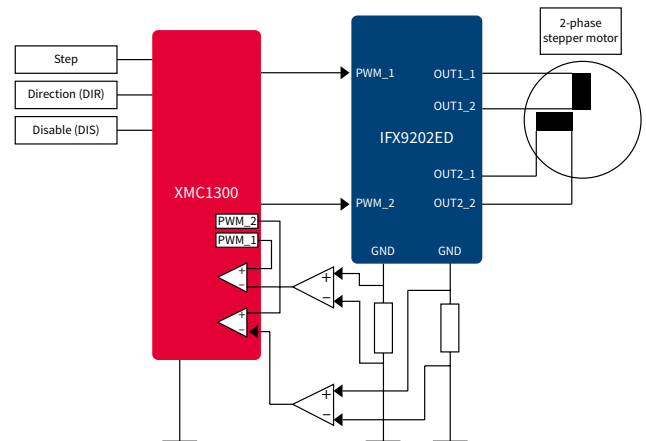
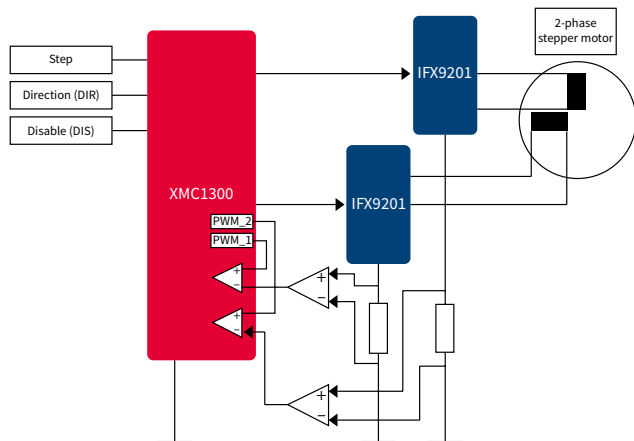
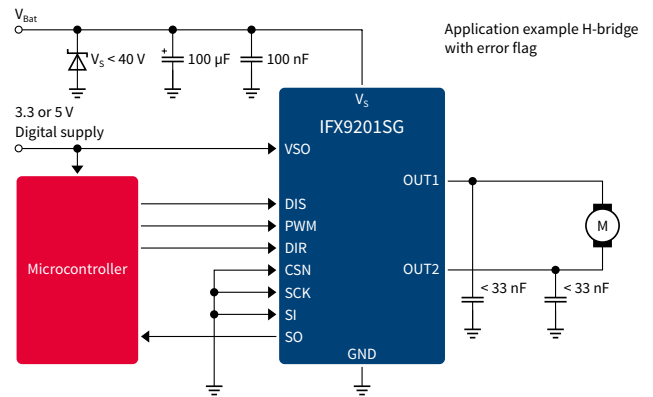
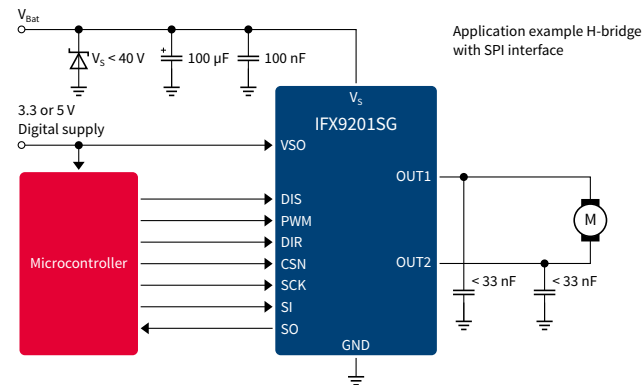

www.infineon.com/dc-motor-bridges

H-bridge Kit 2Go with IFX9201SG

Build your own DC motor control with the H-bridge Kit 2GO, a ready-to-use evaluation kit. It is fully populated with all electronic components equipped with the H-bridge IFX9201 combined with XMC1100 microcontroller based on ARM® Cortex®-M0 CPU. It is designed for the control of DC motors or other inductive loads up to 6 A or up to 36 V of supply.

Target applications

- › DC motor control for industrial applications
- › Home and building automation
- › Power tools battery management
- › Industrial robotic applications
- › Electric toys applications

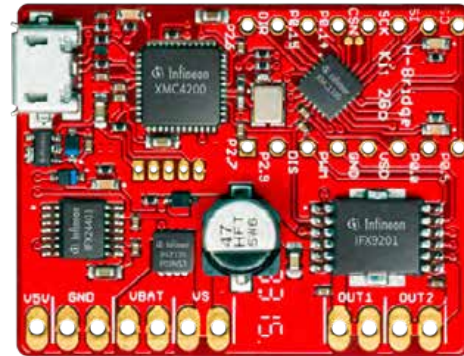

Stepper motor control shield with IFX9201SG and XMC1300 for Arduino

The stepper motor control shield from Infineon is one of the first high current stepper motor control boards being compatible to Arduino as well as to Infineon's XMC1100 boot kit. The stepper motor control shield is capable to drive the two coils in a stepper motors featuring dual-half bridge configuration. The implemented integrated IFX9201 half-bridges can be controlled by a STEP-signal via the STEP pin. Interfacing to a microcontroller is made easy by the integrated XMC1300 microcontroller that holds the peripherals to allow high-speed current control. Microstepping of the stepper motor can be achieved using the internal comparators, while operational amplifiers are installed to adapt the motor current sense signal to the microcontroller's input levels.

Features

- › Compatible with microcontroller boards using the Arduino form factor, e.g. Infineon's XMC™ microcontroller kits
- › Capable of high frequency PWM, e.g. 30 kHz
- › Adjustable slew rates for optimized EMI by changing external resistor
- › Driver circuit with logic level inputs
- › Diagnosis with current sense

Target applications

- › Stepper motors up to 5 A phase current
- › 24 V nominal input voltage for the power stage
- › Average motor current 3 A without additional cooling effort, 5 A possible with proper cooling

www.infineon.com/h-bridge-kit-2go

www.infineon.com/IFX9201SG-stepper-motor-shield

www.infineon.com/makers

Benefits

- › Fast and inexpensive prototyping of stepper motor control
- › Simple testing of microstepping algorithms
- › Diagnose pin to allow hardware feedback during development
- › Overtemperature shutdown with latch behavior and undervoltage shutdown of the power section

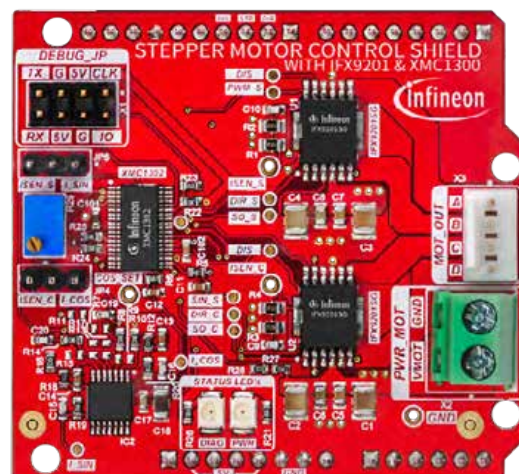

Stepper drivers

Cost-efficient, durable and reliable

The TLE4726G, TCA3727G and TLE8444SL are designed to drive bipolar stepper motors, DC motors and other inductive loads that operate on a constant current. The TLE4726G and TCA3727G have integrated control logic and power output stages for two bipolar windings.

Key features

- > Full to half-step operation
- > Protected bipolar power stages
- > Implemented current control
- > Error flag for diagnosis
- > Overtemperature protection

Applications

- > ATM
- > Franking machines
- > Vending machine
- > Idle speed control
- > Printer
- > Toys



Product number	$I_{L(NOM)}$	$I_{L(lim)}$	I_q [μA]	$V_{S(op)}$	Step operations	Protection	Diagnostic interface	Highlights	Package
TCA3727G	2x0.75	2x1.5	200	5-50	Full to mini-step	OT	-	High operating voltage, low quiescent current with inhibit	PG-DSO-24
TLE4726G	2x0.75	2x1.5	200	5-50	Full to mini-step	OT	-	High operating voltage, low quiescent current with inhibit	PG-DSO-24
TLE8444SL	4x0.50	4x0.90	1	1-18	Full to half-step	SC, OT, OV, UV, OL	Status flag	Open-load detection in on-state	SSOP-24-7

CS = Current sense SC = Short circuit
 OC = Overcurrent UV = Undervoltage
 OT = Overtemperature OL = Open-load

CIPOS™ IPM family

Control integrated power system (CIPOS™) intelligent power modules (IPM)

Depending on the level of integration and power to be handled, Infineon offers a variety of IPMs, with different semiconductors in different packages and different voltage and current classes.

CIPOS™ IPMs are families of highly integrated, compact power modules designed to drive motors in applications ranging from home appliances to fans, pumps, and general purpose drives.

Infineon's energy-efficient IPMs integrate the latest power semiconductor and control IC technology leveraging Infineon's advanced IGBTs, MOSFETs, next-generation gate driver ICs and state-of-the-art thermo-mechanical technology.

CIPOS™ product overview

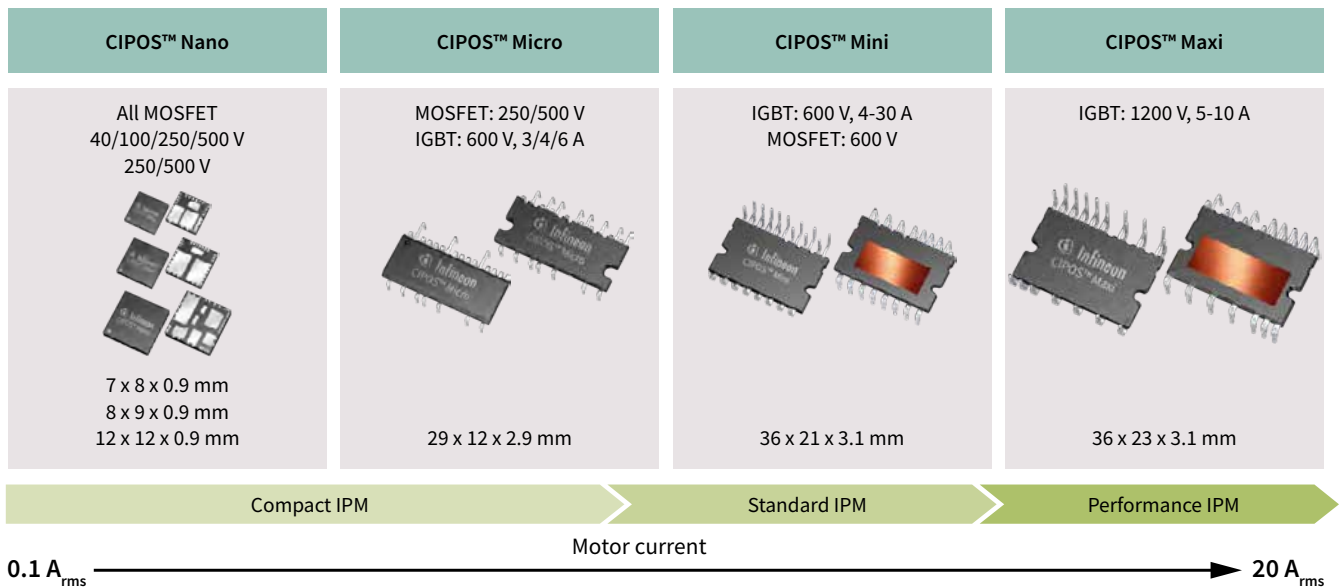

Key benefits

- > Shorter time-to-market
- > Increased reliability
- > Reduced system design complexity
- > Improved manufacturability

www.infineon.com/ipm

CIPOS™ Nano

Three-phase or half-bridge driver with MOSFETs

CIPOS™ Nano is a family of highly integrated, ultracompact IPMs for high efficiency appliance and light industrial applications including rectifiers, converters, inverters in power management circuits and motor drives for hair dryers, air purifiers, ceiling fans, circulation pumps and ventilators. By utilizing an innovative packaging solution, these IPMs delivers a new benchmark in device size, offering up to a 60 percent smaller footprint than existing three-phase motor control power IPMs.

The family is comprised of a series of fully integrated three-phase or half-bridge surface-mount motor control circuit solutions. The new alternative approach utilizes PCB copper traces to dissipate heat from the module, providing cost savings through a smaller package design and even eliminating the need for an external heat sink.

Key features

- › Motor drive-optimized fast recovery FETs
- › Heat sink-less operation
- › Smallest modules on the market
- › Wide range of footprint compatible parts
- › Integrated bootstrap functionality
- › Undervoltage lockout for all channels



Key benefits

- › Cost savings from smaller footprint and reduced PCB space
- › Easy implementation of two or three-phase motor drives with half-bridge IPMs
- › IPMs distribute heat dissipation and enable elimination of heat sink
- › Same PCB footprint to address multiple application markets (100-230 V_{AC})

Key applications

- › Small home appliances
- › Hair driers
- › Air purifiers
- › Fans
- › Motor drives
- › Battery management
- › Water pumps
- › CPAP

Package overview

QFN 12x12 12 x 12 x 0.9 mm	QFN 8x9 8 x 9 x 0.9 mm	QFN 7x8 7 x 8 x 0.9 mm
		

CIPOS™ Micro

Solution for low power motor drive applications

CIPOS™ Micro is a family of compact IPMs for low power motor drive applications including fans, pumps, air purifiers and refrigerator compressor drives.

These IPMs offer cost-effective power solutions by leveraging industry standard footprints and processes compatible with various PCB substrates. The advanced IPMs feature rugged and efficient high voltage MOSFETs and IGBTs specifically optimized for variable frequency drives with voltage ratings of 250~600 V IGBTs. The IPMs offer DC current ratings ranging up to 6 A to drive motors up to 100 W without heatsink and up to 300 W with heatsink, and are available in both through-hole and surface mount package options.

Key features

- › Integrated bootstrap functionality
- › Undervoltage lockout for all channels
- › Matched propagation delay for all channels
- › Optimized dV/dt for loss and EMI trade-off
- › Advanced input filter with shoot-through protection
- › Separate low-side emitter pins for single- or leg-shunt current sensing
- › 3.3 V logic compatible
- › UL certified NTC thermistor for temperature feedback available
- › Various lead forms available including through-hole and surface mounted





Key benefits

- › Ease of design and short time-to-market
- › Compact package with multi lead form options available
- › Wide range of current and voltage ratings in the same package
- › Wide range of modules for 110 V_{AC} or 230 V_{AC} applications in the same footprint
- › Lower losses than similar modules in the market

Key applications

- › Fan motors
- › Low-power general purpose drives (GPI, servo drives)
- › Pumps
- › Blowers
- › Active filter (active power factor correction) for HVAC

Package overview

DIP 29x12 29 x 12 x 3.1 mm	DIP 29x12F 29 x 12 x 3.1 mm	SOP 29x12 29 x 12 x 3.1 mm	SOP 29x12F 29 x 12 x 3.1 mm
			

www.infineon.com/ipm

CIPOS™ Mini

Broad range of applications from PFC to inverter

CIPOS™ Mini IPMs integrate various power and control components to increase reliability, and to optimize PCB size and system costs. This simplifies the power design and reduces significantly time-to-market.

The IPMs are designed to control AC motors in variable speed drives for applications from 4 A up to 30 A such as air conditioning, washing machines, refrigerators, vacuum cleaners, compressors, and industrial drives up to 3 kW.

The package concept is specially adapted to power applications that need good thermal conduction and electrical isolation, EMI-safe control, innovative fault indication, and overload protection. The feature of Infineon's reverse conducting IGBTs or TRENCHSTOP™ IGBTs are used with a new optimized Infineon SOI gate driver IC for excellent electrical performance.

Key features

- › Dual-in-line transfer molded package with DCB substrate
- › Current rating from 4 A to 30 A, power rating up to 3 kW
- › Optimized for home appliances and motor drives
- › Rugged SOI gate driver IC technology
- › Advanced protection features
- › UL1577 certified

Key benefits

- › High integration (bootstrap circuit, thermistor) for easy design and system space saving
- › Single platform possible from 4 A to 30 A
- › Enhanced robustness of the advanced IGBT and gate driver IC technology
- › High power density
- › Two kinds of substrates provide cost efficient solution for home appliances
- › UL-certified thermistor

Key applications

- › Fan motors
- › Low-power general purpose drives (GPI, servo drives)
- › Pumps
- › Blowers
- › Active filter (active power factor correction) for HVAC

Package overview

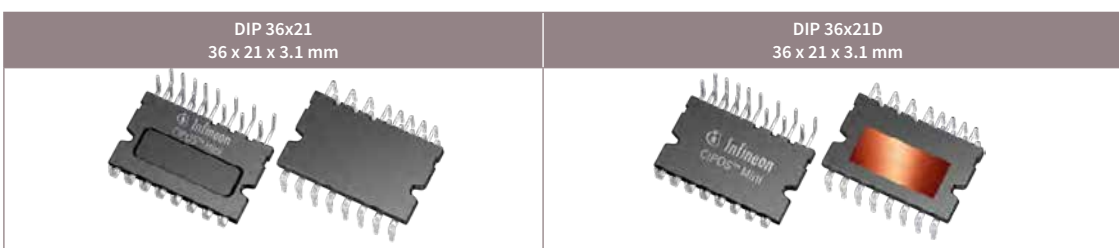

www.infineon.com/ipm

CIPOS™ Maxi

Solutions for high reliability and performance application

CIPOS™ Maxi IPMs integrate various power and control components to increase reliability, optimize PCB size and system costs. It is designed to control three-phase AC motors and permanent magnet motors in variable speed drives applications, such as low-power motor drives, pumps, fan drives and active filters for HVAC (heating, ventilation, and air conditioning). The existing portfolio offers 5 A and 10 A in 1200 V class up to 1.8 kW power rating. The smallest package in 1200 V IPM class offers highest power density and best performance in its class.

IM818 is the first 1200 V IPM that integrated an optimized 6-channel SOI gate driver to provide built-in dead time that prevents damage from transients. The product concept is especially adapted to power applications, which require excellent thermal performance and electrical isolation as well as meeting EMI requirements and overload protection.

Key features

- › Fully isolated dual in-line molded module with DCB
- › 1200 V TRENCHSTOP™ IGBT 4
- › Rugged 1200 V SOI gate driver technology
- › Integrated bootstrap functionality
- › Overcurrent shutdown
- › Undervoltage lockout at all channels
- › All of six switches turn-off during protection
- › Cross-conduction prevention
- › Programmable fault clear timing
- › Allowable negative VS potential up to -11 V for signal transmission at V_{BS} of 15 V
- › Low side emitter pins accessible for all phase current monitoring (open emitter)

Key benefits

- › The smallest package size in 1200 V IPM class with high power density and best performance
- › Enhanced robustness of gate driver technology for excellent protection
- › Adapted to high switching application with lower power loss
- › Simplified design and manufacturing

Package overview

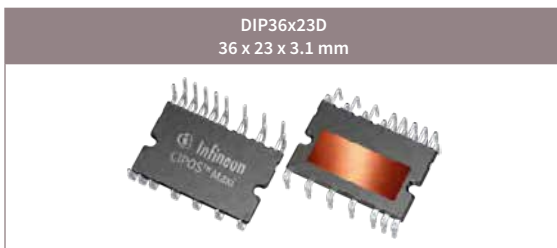

www.infineon.com/ipm



Applications

20-300 V MOSFETs

500-950 V MOSFETs

WBG semiconductors

Discrete IGBTs

Power ICs

Gate driver ICs

Motor control ICs

Microcontrollers

XENSIV™ sensors

Packages

CIPOS™ IPM product portfolio

MOSFET based CIPOS™ IPMs					
Product family	Voltage [V]	Configuration	R _{DS(on)} max. [Ω]	Package	Product name
CIPOS™ Nano	40	Half-bridge	0.05	QFN 7x8	IRSM005-800MH
	100	Half-bridge	0.02	QFN 7x8	IRSM005-301MH
	250	Half-bridge	0.15	QFN 8x9	IRSM808-204MH
		3-phase inverter	0.45. ~ 2.20	QFN 12x12	IRSM836-084MA/IRSM836-044MA IRSM836-024MA
	500	Half-bridge	0.80/1.70	QFN 8x9	IRSM807-105MH/IRSM808-105MH IRSM807-045MH
		3-phase inverter	1.70 ~ 6.00	QFN 12x12	IRSM836-045MA/IRSM836-035MA/IRSM836-035MB IRSM836-025MA/IRSM836-015MA
CIPOS™ Micro	250	3-phase inverter	0.45. ~ 2.20	DIP 29x12F	IRSM5y5-084DA/IRSM5y5-044DA ¹⁾ IRSM5y5-024DA ¹⁾
			0.45. ~ 2.20	SOP 29x12F	IRSM5y5-084PA/IRSM5y5-044DPA ¹⁾ IRSM5y5-024PA ¹⁾
	500		1.30 ~ 6.00	DIP 29x12F	IRSM5y5-065DA/IRSM5y5-055DA ¹⁾ IRSM5y5-035DA/IRSM5y5-025DA ¹⁾ IRSM5y5-015DA ¹⁾
			1.30 ~ 6.00	SOP 29x12F	IRSM5y5-065PA/IRSM5y5-055PA ¹⁾ IRSM5y5-035PA/IRSM5y5-025PA ¹⁾ IRSM5y5-015PA ¹⁾
CIPOS™ Mini	600	2/3-phase inverter	0.33	DIP 36x21	IM512-L6A/IM513-L6A

IGBT based CIPOS™ IPMs							
Product family	Voltage [V]	Configuration	Rated current [A]	Package	Product name		
CIPOS™ Micro	600	3-phase inverter	3.0/4.0	DIP 29x12F	IM240-S6Y1B/IM240-S6Y2B IM240-M6Y1B/IM240-M6Y2B/IRSM5y6-076DA ¹⁾		
			4.0/6.0	DIP 29x12	IM231-M6T2B/IM231-L6T2B		
			3.0/4.0	SOP 29x12F	IM240-S6Z1B IM240-M6Z1B/IRSM5y6-076PA ¹⁾		
			4.0/6.0	SOP 29x12	IM231-M6S1B/IM231-L6S1B		
CIPOS™ Mini	600	PFC integrated	10.0/15.0	DIP 36x21D	IFCM10S60GD/IFCM10P60GD IFCM15S60GD/IFCM15P60GD		
		3-phase inverter	4.0 ~ 30.0	DIP 36x21	IGCM04F60yA/IGCM04G60yA ²⁾ IGCM06F60yA/IGCM06G60yA ²⁾ IGCM10F60yA/IKCM10H60yA/IKCM10L60yA ²⁾ IGCM15F60yA/IKCM15L60yA/IKCM15F60yA/IKCM15H60yA ²⁾ IGCM20F60yA/IKCM20L60yA ²⁾ IKCM30F60yA ²⁾		
					15.0 ~ 30.0	DIP 36x21D	IKCM15L60yD/IKCM20L60yD/IKCM30F60yA ²⁾
					20	DIP 36x21D	IFCM20T65GD/IFCM20U65GD
	650	3-phase interleaved PFC	30	DIP 36x21D	IFC30T65GD/IFCM30U65GD		
2-phase interleaved PFC		30	DIP 36x21D	IFC30T65GD/IFCM30U65GD			
CIPOS™ Maxi	1200	3-phase inverter	5.0/10.0	DIP 36x23D	IM818-SCC/IM818-MCC		

1) y = 0 (with NTC), y = 1 (without NTC)

2) y = G (with NTC), y = H (without NTC)



Infineon support for power ICs

Useful links and helpful information

Further information, datasheets and documents

- www.infineon.com/acdc
- www.infineon.com/coolset
- www.infineon.com/integrated-powerstages
- www.infineon.com/digital-controller
- www.infineon.com/lighting-ics
- www.infineon.com/isoface
- www.infineon.com/eicedriver
- www.infineon.com/industrial-transceivers
- www.infineon.com/industrial-voltage-regulators
- www.infineon.com/industrial-dcdc-converters

- www.infineon.com/industrial-profet
- www.infineon.com/novalithic
- www.infineon.com/dc-motor-bridges
- www.infineon.com/shields-for-arduino
- www.infineon.com/ipol
- www.infineon.com/analog-ipol
- www.infineon.com/xdp
- www.infineon.com/ipm
- www.infineon.com/madk

Videos and eLearnings

www.infineon.com/mediacenter

-  Info
-  Document
-  Evaluation Board
-  Tools
-  Simulation
-  Play



Industrial and general purpose gate driver ICs

The expert's choice

Leveraging the application expertise and advanced technologies of Infineon, the industrial and general purpose gate driver ICs are well suited for many applications such as industrial motor drives, solar inverters, UPS, switch mode power supplies, lighting and major home appliances. Infineon offers a comprehensive portfolio of industrial and general purpose gate driver ICs with a variety of configurations, voltage classes, isolation levels, protection features, and package options. These flexible gate driver ICs are complementary to Infineon IGBTs, MOSFETs, SiC MOSFET, GaN HEMTs and other power switches in discrete gate drive applications, or as a part of integrated power modules.

EiceDRIVER™ 1EDN family

Rugged, cool and fast, single-channel low-side 4/8 A gate driver ICs

EiceDRIVER™ 1EDN family

Single-channel MOSFET gate driver ICs are the crucial link between control ICs and powerful MOSFET and GaN switching devices. Gate driver ICs enable high system level efficiencies, excellent power density and consistent system robustness.

EiceDRIVER™ 1EDN family: fast, precise, strong and compatible

- > Highly efficient SMPS enabled by 5 ns short slew rates and ± 5 ns propagation delay precision for fast MOSFET and GaN switching
- > Separate source and sink outputs simplify the application design
- > Industry standard packages and pinout ease system design upgrades

EiceDRIVER™ 1EDN family: the new reference in ruggedness and low power dissipation

- > -10 V robustness of control and enable inputs provides crucial safety margin when driving pulse transformers
- > 5 A reverse output current robustness eliminates the need for Schottky switching diodes when driving MOSFETs in TO-220 and TO-247 packages
- > Cool driver ICs thanks to true rail-to-rail low impedance output stages
- > 4 V and 8 V UVLO (undervoltage lockout) options for instant MOSFET protection during start-up and under abnormal conditions

Applications

- > PFC
- > Synchronous rectification
- > DC-DC converters
- > Telecom bricks
- > Power tools
- > Industrial SMPS
- > Motor control
- > Wireless charging





www.infineon.com/1edn

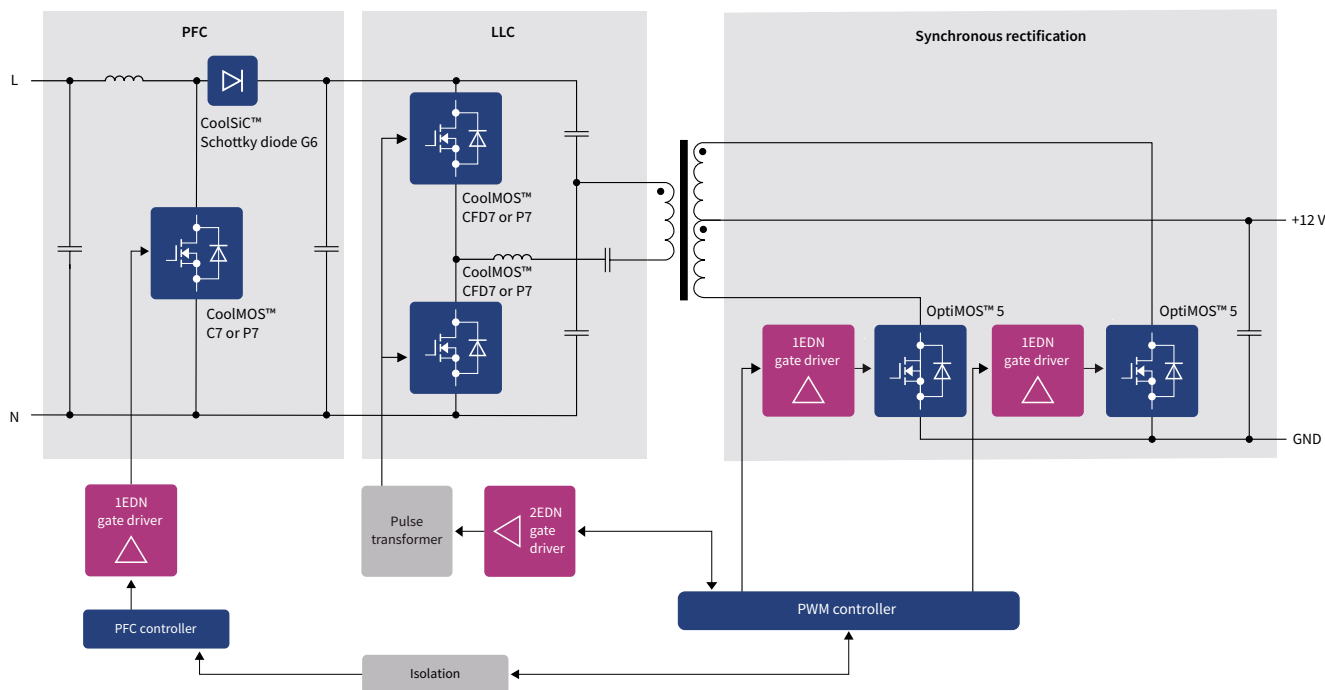

Product features	Product benefits	Application benefits
<ul style="list-style-type: none"> > 4 A source/8 A sink current > 6 ns rise/5 ns fall times > ± 5 ns propagation delay precision 	<ul style="list-style-type: none"> > Fast Miller plateau transition > Precise timing 	<ul style="list-style-type: none"> > High power efficiency <ul style="list-style-type: none"> - in hard switching PFC with SiC diode - in half-bridges and synchronous rectifications
<ul style="list-style-type: none"> > True rail-to-rail low impedance output stages 	<ul style="list-style-type: none"> > Low power dissipation in driver IC 	<ul style="list-style-type: none"> > Cooler driver IC operation > Higher MOSFET drive capability
<ul style="list-style-type: none"> > 4 V and 8 V UVLO options > 19 ns propagation delay 	<ul style="list-style-type: none"> > Fast and reliable MOSFET turn-off, independent of control IC 	<ul style="list-style-type: none"> > Instant MOSFET protection during start-up and under abnormal operation
<ul style="list-style-type: none"> > -10 V robustness of inputs 	<ul style="list-style-type: none"> > Increased GND-bounce robustness 	<ul style="list-style-type: none"> > Crucial safety margin to drive pulse transformer
<ul style="list-style-type: none"> > 5 A reverse output current robustness 	<ul style="list-style-type: none"> > Saving switching diodes 	<ul style="list-style-type: none"> > Increases power density > BOM savings
<ul style="list-style-type: none"> > Industry standard pinout and packages 	<ul style="list-style-type: none"> > Straight forward design upgrades 	<ul style="list-style-type: none"> > Short time-to-market

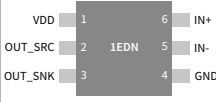
Application overview: 800 W switched mode power supply

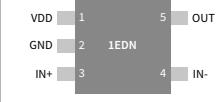

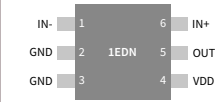
Package	UVLO	Product name	Orderable part number	Pinout
 SOT-23 6-pin	4 V	1EDN7511B	1EDN7511BXUSA1	
	8 V	1EDN8511B	1EDN8511BXUSA1	
 SOT-23 5-pin	4 V	1EDN7512B	1EDN7512BXTSA1	
 WSON 6-pin	4 V	1EDN7512G	1EDN7512GXTMA1	

EiceDRIVER™ 1EDN7550 and 1EDN8550

Single-channel low-side gate driver family with truly differential inputs prevents false triggering of power MOSFETs

Overview

The input signal levels of conventional low-side gate driver ICs are referenced to the ground potential of the gate driver IC. If in the application, the ground potential of the gate driver IC shifts excessively false triggering of the gate driver IC can occur.

The 1EDN7550/1EDN8550 gate driver ICs have truly differential inputs. Their control signal inputs are largely independent from the ground potential. Only the voltage difference between its input contacts is relevant. This prevents false triggering of power MOSFETs.

Applications

- > Server
- > Telecom
- > DC-DC converters
- > Telecom bricks
- > Power tools
- > Industrial SMPS
- > Wireless charging
- > Solar micro inverter

Product features	Product benefits	Application benefits
<ul style="list-style-type: none"> > Truly differential inputs 	<ul style="list-style-type: none"> > Control inputs independent from gate driver GND 	<ul style="list-style-type: none"> > Robust against ground shifts from power MOSFET switching
<ul style="list-style-type: none"> > 4 A source current > 8 A sink current > Separate source/sink outputs > Low-ohmic output stage 	<ul style="list-style-type: none"> > Fast Miller plateau transition > Fast shut-off > No diode voltage drop → near zero gate voltage at turn-off > Low power dissipation within gate driver IC 	<ul style="list-style-type: none"> > Low MOSFET switching losses > Robust against false MOSFET triggering > Highest effective MOSFET driving power
<ul style="list-style-type: none"> > 29 ns input minimum pulse width > 7 ns propagation delay accuracy 	<ul style="list-style-type: none"> > Up to 15 MHz switching speed > Precise 	<ul style="list-style-type: none"> > Efficiency gains
<ul style="list-style-type: none"> > 5 A reverse current robustness of the outputs > 4 V and 8 V UVLO versions 	<ul style="list-style-type: none"> > No Schottky clamping diodes required > Fast and reliable MOSFET turn-off 	<ul style="list-style-type: none"> > Increased power density and BOM savings > Instant MOSFET protection under abnormal operation
<ul style="list-style-type: none"> > SOT-23 package, 6 pins 	<ul style="list-style-type: none"> > Small 	<ul style="list-style-type: none"> > High power density

Pinout

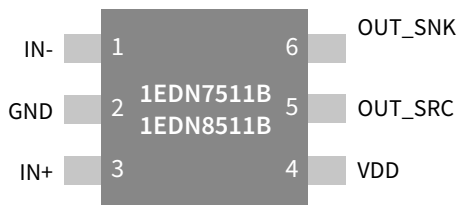

1EDN7550 driving CoolMOS™ SJ MOSFET on single-layer PCB

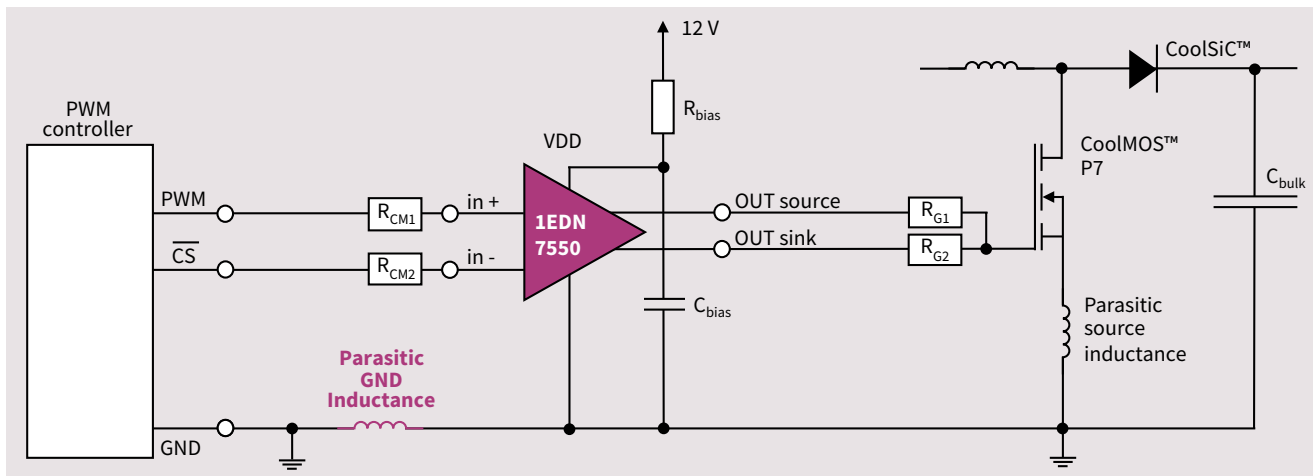

1EDN8550 driving Kelvin source CoolMOS™ SJ MOSFET in boost PFC

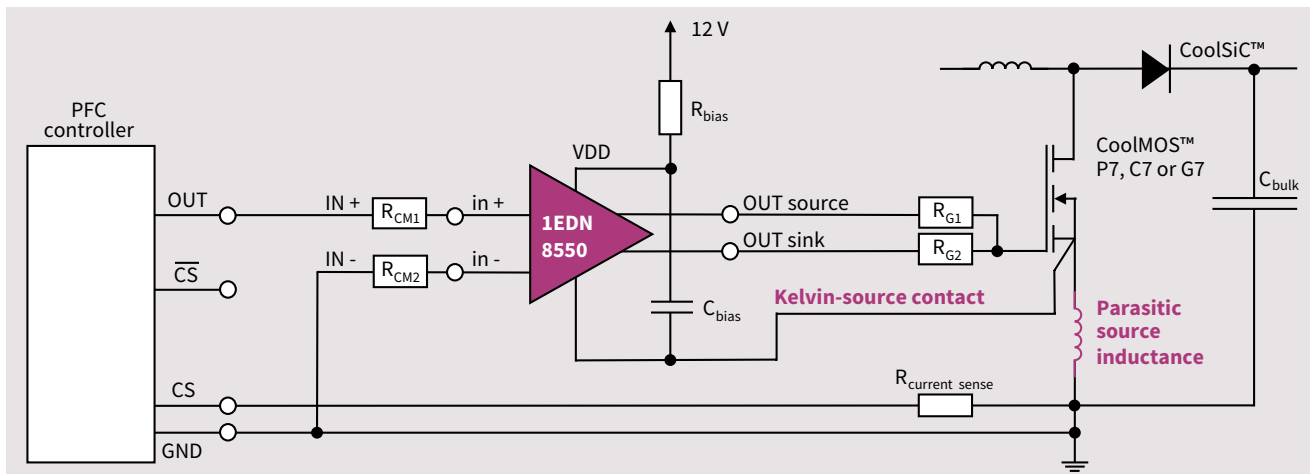

Type	Ground shift robustness		UVLO	Package	Orderable part number
	dynamic	static			
1EDN7550B	+/- 150 V	+/- 70 V	4 V	SOT-23 6-pin	1EDN7550BXTSA1
1EDN8550B	+/- 150 V	+/- 70 V	8 V	SOT-23 6-pin	1EDN8550BXTSA1

EiceDRIVER™ 2EDN family

Rugged, cool and fast, dual-channel low-side 4 A/5 A driver IC

EiceDRIVER™ 2EDN family overview

Dual-channel driver ICs are the crucial link between digital control ICs and powerful MOSFET and GaN switching devices. Driver ICs enable high system level efficiencies, excellent power density and consistent system robustness.

EiceDRIVER™ 2EDN family: fast, precise, strong and compatible

- › Highly efficient SMPS enabled by 5 ns short slew rates and 10 ns propagation delay precision for fast MOSFET and GaN switching
- › Numerous deployment options due to two 4 A/5 A channels. 1 ns channel-to-channel accuracy to use two channels in parallel
- › Industry standard packages and pinout ease system design upgrades

EiceDRIVER™ 2EDN family: the new reference in ruggedness and low power dissipation

- › 4 V and 8 V UVLO (undervoltage lockout) options for instant MOSFET protection under abnormal conditions
- › -10 V robustness of control and enable inputs provides crucial safety margin when driving pulse transformers or driving MOSFETs in TO-220 and TO-247 packages
- › 5 A reverse output current robustness eliminates the need for Schottky switching diodes and reduces bill-of-material
- › Cool driver ICs from true rail-to-rail low impedance output stages

Applications

- › Server
- › Telecom
- › DC-DC converters
- › Bricks
- › Power tools
- › Industrial SMPS
- › Motor control
- › Solar

Package overview





Product features	Product benefits	Application benefits
<ul style="list-style-type: none"> › 5 A source/sink current › 5 ns rise/fall times › <10 ns propagation delay precision 	<ul style="list-style-type: none"> › Fast Miller plateau transition › Precise timing 	<ul style="list-style-type: none"> › High power efficiency <ul style="list-style-type: none"> – in hard switching PFC with SiC diode – in half-bridges and synchronous rectifications
<ul style="list-style-type: none"> › True rail-to-rail low impedance output stages 	<ul style="list-style-type: none"> › Low power dissipation in driver IC 	<ul style="list-style-type: none"> › Cooler driver IC operation › Higher MOSFET drive capability
<ul style="list-style-type: none"> › 4 V and 8 V UVLO options › 19 ns propagation delay for both control and enable inputs 	<ul style="list-style-type: none"> › Fast and reliable MOSFET turn-off, independent of control IC 	<ul style="list-style-type: none"> › Instant MOSFET protection under abnormal operation
<ul style="list-style-type: none"> › -10 V robustness of control and enable inputs 	<ul style="list-style-type: none"> › Increased GND-bounce robustness 	<ul style="list-style-type: none"> › Crucial safety margin to drive pulse transformer
<ul style="list-style-type: none"> › 5 A reverse output current robustness 	<ul style="list-style-type: none"> › Saves switching diodes 	<ul style="list-style-type: none"> › Increases power density › BOM savings
<ul style="list-style-type: none"> › 2 independent channels › Excellent 1 ns channel-to-channel accuracy 	<ul style="list-style-type: none"> › Option to increase drive current by truly concurrent switching of 2 channels 	<ul style="list-style-type: none"> › One IC covering many applications
<ul style="list-style-type: none"> › Industry standard pinout and packages 	<ul style="list-style-type: none"> › Straight forward design upgrades 	<ul style="list-style-type: none"> › Short time to market

www.infineon.com/2edn

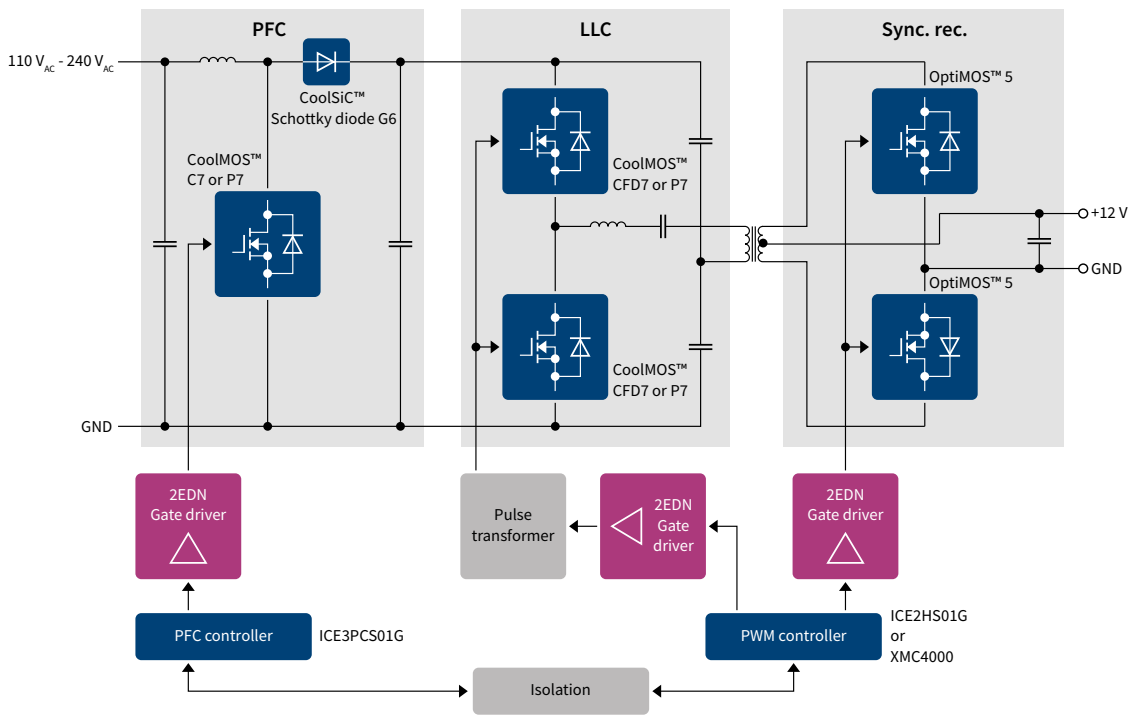
Application overview 800 W 130 kHz switched mode power supply



Package	UVLO	Inputs	Product name	Orderable part number	Current
 DSO 8-pin	4 V	Direct	2EDN7524F	2EDN7524FXTMA1	5 A
		Inverted	2EDN7523F	2EDN7523FXTMA1	
		Direct	2EDN7424F	2EDN7424FXTMA1	
	8 V	Direct	2EDN8524F	2EDN8524FXTMA1	5 A
		Inverted	2EDN8523F	2EDN8523FXTMA1	
		Direct	2EDN7424R	2EDN7424RXUMA1	
 TSSOP 8-pin	4 V	Direct	2EDN7524R	2EDN7524RXUMA1	5 A
		Inverted	2EDN7523R	2EDN7523RXUMA1	
		Direct	2EDN7424R	2EDN7424RXUMA1	
	8 V	Direct	2EDN8524R	2EDN8524RXUMA1	5 A
		Inverted	2EDN8523R	2EDN8523RXUMA1	
		Direct	2EDN7524G	2EDN7524GXTMA1	
 WSO 8-pin	4 V	Direct	2EDN7524G	2EDN7524GXTMA1	5 A
		Inverted	2EDN7523G	2EDN7523GXTMA1	

Industry standard pinout configuration

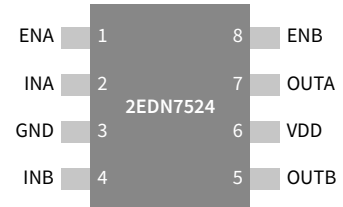

EiceDRIVER™ 2EDi product family

Fast, robust, dual-channel, functional and reinforced isolated MOSFET gate drivers with accurate and stable timing

2EDi family overview

The EiceDRIVER™ 2EDi product family is designed for use in high-performance power conversion applications. Very strong 4 A/8 A source/sink dual-channel gate drivers increase efficiency in CoolMOST™ and OptiMOS™ MOSFET half-bridges. The low propagation delay of 37 ns, combined with highly accurate and stable timing overtemperature and production, enables further efficiency gains within and across galvanically isolated power stages or in multi-phase/multi-level topologies. The availability of functional and reinforced isolated drivers in different packages makes these a perfect fit for both primary side and (safe) secondary side control. Gate driver outputs come with a high 5 A reverse current capability and 150 V/ns CMTI robustness for high dv/dt power loops. For slower switching or driving smaller MOSFETs, 1 A/2 A peak current product variants are available as well.

Product key features	Product benefits	System benefits
Fast power switching with accurate timing <ul style="list-style-type: none"> Available with 4 A/8 A and 1 A/2 A source/sink currents Propagation delay typ. 37 ns with 3 ns channel-to-channel mismatch Max. delay variation ~14 ns 	Efficiency gain and lower losses <ul style="list-style-type: none"> Lower switching losses in half-bridges due to fast and accurate turn on/off Perfect for new digital, fast high resolution PWM control including light load optimization 	Enabling higher system efficiency and higher power density designs
Optimized for area and system BOM <ul style="list-style-type: none"> Isolation and driver in one package Low power dissipation due to low on-resistance Output stages with 5A reverse current capability 	Improved thermal behavior at smaller form factor <ul style="list-style-type: none"> LGA with 1 mm, DSO with 2.3 mm package height versus volume > 1 cm³ for pulse transformers Eliminates two costly protection diodes on the gate driver outputs 	Improving long term competitive cost position, integration and mass manufacturability
Robust design against switching noise <ul style="list-style-type: none"> Floating drivers are able to handle large inductive voltage over- and undershoots Very good common mode transient immunity CMTI >150 V/ns Undervoltage lockout function for switch protection 	Protection and safe operation <ul style="list-style-type: none"> Ideal for use in high power designs with fast switching transients Reliable CT coreless transformer PWM signal chain to turn on high side MOSFETs 	Extending end-product lifetime by improving safe operation of power switches in normal and abnormal field (grid) conditions
Output- to -output channel isolation <ul style="list-style-type: none"> Functional level galvanic isolation 	Flexible configurations <ul style="list-style-type: none"> HS+LS, HS+HS, LS+LS or 2x I_{max} on 1xHS 	Lower EMI by ground isolation, driver proximity to MOSFETs or the use of 4-pin Kelvin source MOSFETs
Input- to output channel isolation <ul style="list-style-type: none"> Functional and reinforced galvanic isolation 	Regulatory safety <ul style="list-style-type: none"> Functional for primary-side control Reinforced for secondary-side control 	Simplified safety approval through component (VDE884-x, UL1577) and system (IEC60950, IEC62386) certificates

Device overview

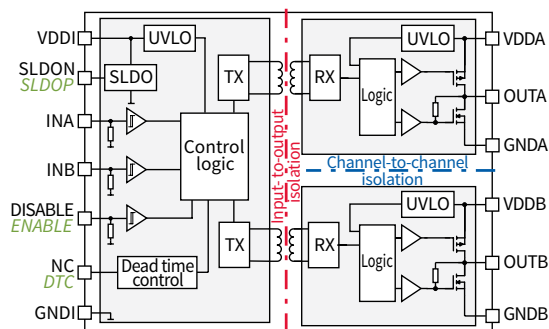

EiceDRIVER™ 2EDi product family device diagram



www.infineon.com/2edi

System application diagram

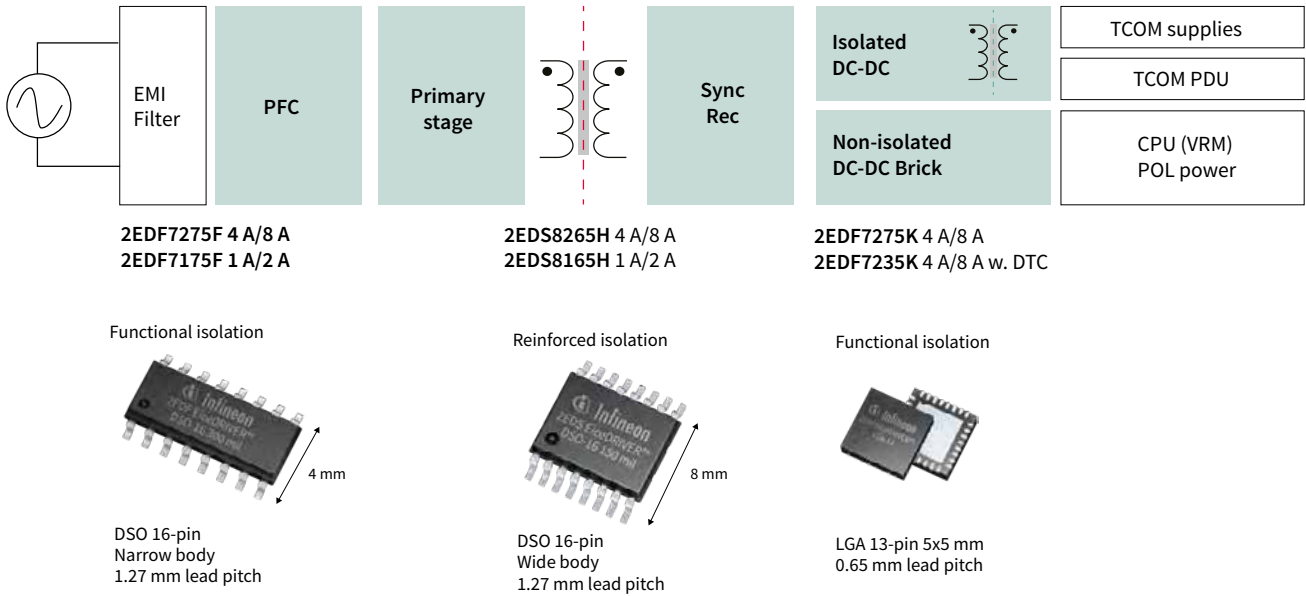

Part number	Orderable part number (OPN)	Package	PWM Input type	Driver source/ Sink current	Gate driver UVLO	Input to output isolation				Dead-time control
						Isolation class	Rating	Surge testing	Safety certification	
2EDF7275F	2EDF7275FXUMA1	NB-DSO16 10 x 6 mm	Dual Mode (IN_A, IN_B)	4 A/8 A	4 V	Functional	$V_{IO} = 1.5 \text{ kV}_{DC}$	n.a.	n.a.	no
2EDF7175F	2EDF7175FXUMA1			1 A/2 A						
2EDF7275K	2EDF7275KXUMA1	4 A/8 A		yes						
2EDF7235K	2EDF7235KXUMA1	LGA13 5.0 x 5.0 mm								
2EDS8265H	2EDS8265HXUMA1	WB-DSO16 10.3 x 10.3 mm		8 V	Reinforced	$V_{IOTM} = 8 \text{ kV}_{peak}$ (VDE0884-1x) $V_{ISO} = 5.7 \text{ kV}_{rms}$ (UL1577)	$V_{IOSM} = 10 \text{ kV}_{peak}$ (IEC60065)	VDE0884-10 UL1577 IEC60950 IEC62368 CQC	no	
2EDS8165H	2EDS8165HXUMA1			1 A/2 A						

For further latest device information, configurations and application notes visit www.infineon.com/2EDI

GaN EiceDRIVER™ family

Single-channel isolated gate driver ICs for high voltage GaN switches

CoolGaN™ e-mode HEMTs are best driven by Infineon's EiceDRIVER™ ICs, the 1EDF5673K, 1EDF5673F and 1EDS5663H. They ensure robust and highly efficient high voltage GaN switch operation whilst concurrently minimizing R&D efforts and shortening time-to-market.

Key advantages of designing with the GaN EiceDRIVER™ family

Positive and negative gate drive currents:

- › Fast turn-on/turn-off GaN switch slew-rates

Firmly hold gate voltage at zero, during off-phase:

- › Avoids spurious GaN switch turn-on
- › Up to 50% lower dead time losses

Configurable and constant GaN switching slew-rates, across wide range of switching frequency and duty-cycle:

- › Robust and energy efficient SMPS designs
- › Short time to market

Integrated galvanic isolation:

- › Robust operation in hard-switching applications
- › Safe isolation where needed

Key use cases

- › Totem pole PFCs
- › Vienna rectifiers
- › Multilevel topologies
- › Resonant LLC

Key applications

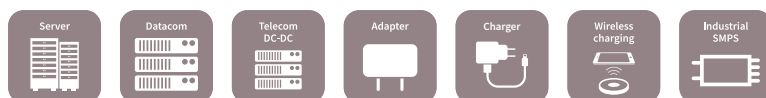

Key features

Low ohmic outputs:

- › Source: 0.85 Ω
- › Sink: 0.35 Ω
- › Single-channel galvanic isolation:

Functional:

- › $V_{IO} = 1500 V_{DC}$
- › $V_{IOWM} = 510 V_{rms}$ (DSO 16-pin)
- › $V_{IOWM} = 460 V_{rms}$ (LGA 5x5)

Reinforced:

- › $V_{IOTM} = 8000 V_{pk}$
(VDE 0884-10 pending)
- › $V_{IOWM} = 1420 V_{DC}$
- › CMTI min: 200 V/ns

Timing:

- › Minimum output pulse width: 18 ns
- › Propagation delay accuracy: 13 ns

GaN EiceDRIVER™ ICs evaluation environment

High frequency (1 MHz) half-bridge evaluation board EVAL_1EDF_G1_HB_GAN

Key components:

GaN switches: 2x CoolGaN™ 600 V e-mode HEMTs (IGOT60R070D1)

GaN drivers: 2x GaN EiceDRIVER™ (1EDF5673K)



Order code: EVAL_1EDF_G1_HB_GAN

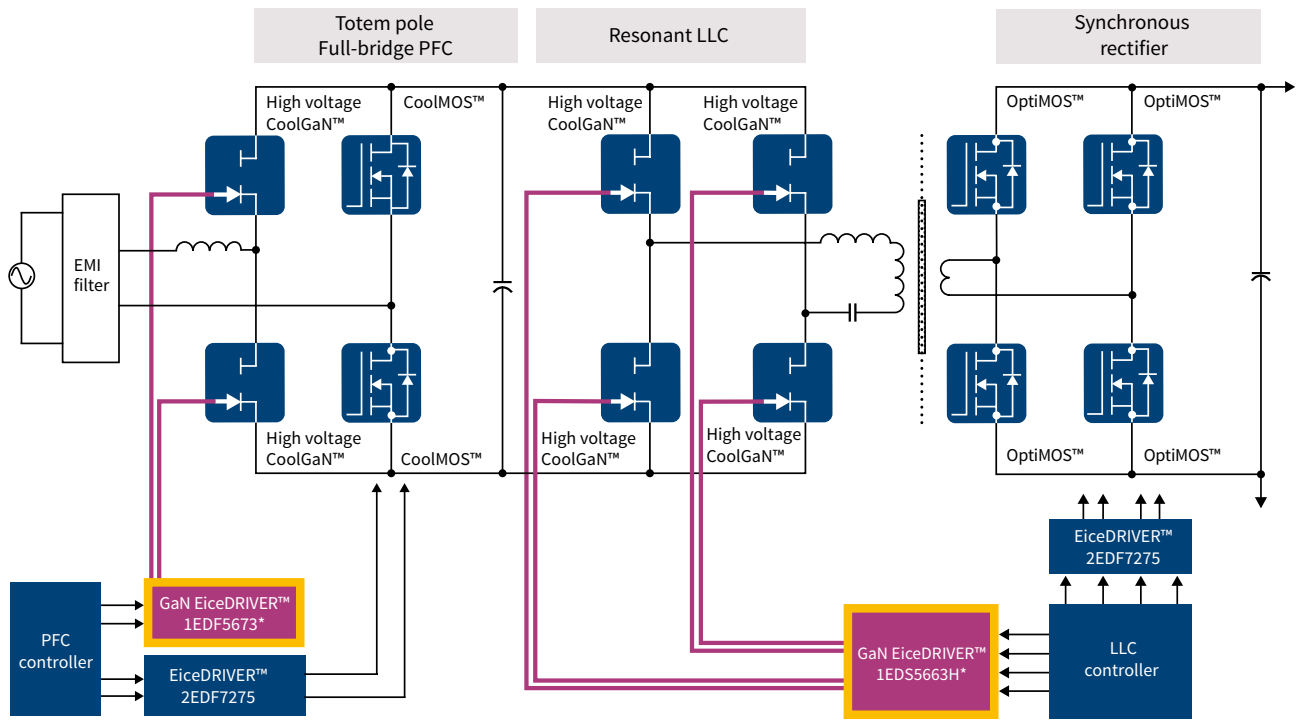

High power SMPS application example



*GaN EiceDRIVER™ ICs are single-channel products

	LGA 13-pin 5x5 mm	DSO 16-pin 150 mil	DSO 16-pin 300 mil
Package			
Product	1EDF5673K	1EDF5673F	1EDS5663H
OPN	1EDF5673KXUMA1	1EDF5673FXUMA1	1EDS5663HXUMA1
Isolation (input to output)	$V_{IO} = 1500 V_{DC}$	$V_{IO} = 1500 V_{DC}$	$V_{OTM} = 8000 V_{PK}$ (VDE0884-10 pending)
Source/sink output resistance	0.85 Ω /0.35 Ω	0.85 Ω /0.35 Ω	0.85 Ω /0.35 Ω
UVLO	4.5 V / 5.0 V	4.5 V / 5.0 V	4.5 V / 5.0 V

Level-shift silicon-on-insulator (SOI) gate driver ICs

2ED2304S06F - 650 V half-bridge gate driver with integrated bootstrap diode (BSD)

The 2ED2304S06F is a 650-V half-bridge gate driver. Its Infineon thin-film-SOI technology provides excellent ruggedness and noise immunity. The output drivers feature a high pulse current buffer stage designed for minimum driver cross-conduction. The floating channel can be used to drive an N-channel power MOSFET or IGBT in the high side configuration which operates up to 650 V. Additionally, the offline clamping function provides an inherent protection of the parasitic turn-on by floating gate conditions when IC is not supplied.



Typical application diagram

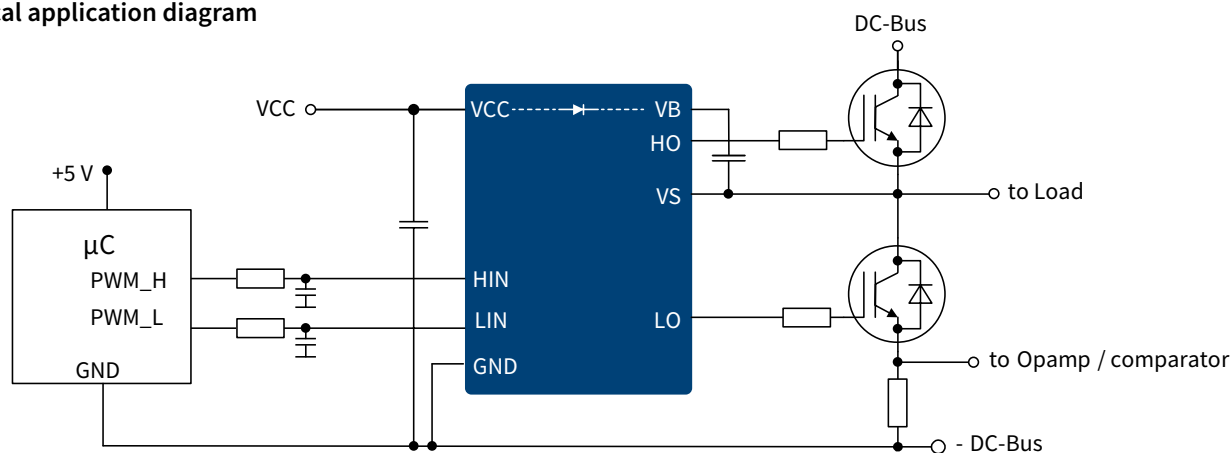

Product features

- › Infineon thin-film SOI technology
- › Fully operational to +650 V
- › Floating channel designed for bootstrap operation
- › Output source/sink current capability +0.36 A/-0.7 A
- › Integrated ultrafast, low $R_{DS(ON)}$ bootstrap diode
- › Tolerant to negative transient voltage up to -50 V (pulse width is up 500 ns) given by SOI technology
- › 10 ns typ., 60 ns max. propagation delay matching
- › dV/dt immune ± 50 V
- › Gate drive supply range from 10 to 20 V
- › Undervoltage lockout for both channels
- › 3.3 V, 5 V and 15 V input logic compatible
- › RoHS compliant

Potential applications

- › Motor drives, general purpose inverters
- › Refrigeration compressors
- › Half-bridge and full-bridge converters in offline AC-DC power supplies for telecom and lighting

Power dissipation of Infineon SOI

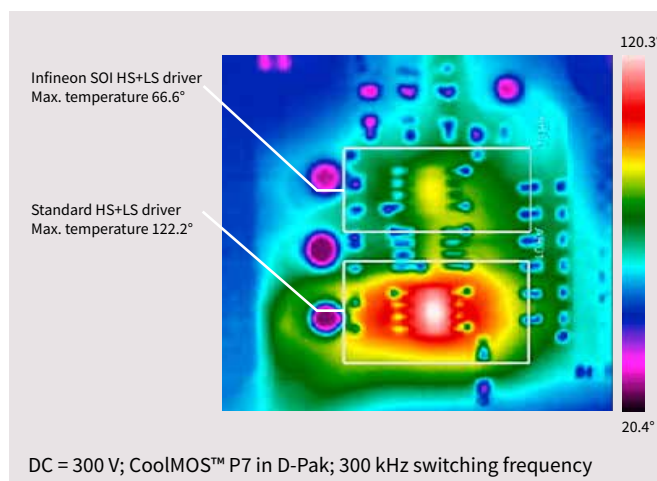

6ED2230S12T - 1200 V three-phase gate driver with overcurrent protection and integrated bootstrap diode (BSD)*

The 6ED2230S12T is a 1200 V three-phase SOI gate driver with an integrated bootstrap diode and overcurrent protection, with typical 0.35 A source and 0.65 A sink currents in a DSO-24 package (DSO-28 with 4 pins removed) for driving IGBTs. Proprietary HVIC and latch-immune CMOS technologies enable a robust monolithic design. A current-trip function which terminates all six outputs can also be derived from this resistor. An open-drain FAULT signal is provided to indicate that an overcurrent or undervoltage shutdown has occurred. Fault conditions are cleared automatically after a delay programmed externally via an RC network. The output drivers feature a high-pulse current buffer stage designed for minimum driver cross conduction. Propagation delays are matched to simplify the HVIC's use in high-frequency applications.



Product features

- > Infineon thin-film SOI technology
- > Fully operational to +1200 V
- > Floating channel designed for bootstrap operation
- > Output source/sink current capability +0.35 A/-0.65 A
- > Integrated ultrafast, low $R_{DS(ON)}$ bootstrap diode
- > Tolerant to negative transient voltage up to -100 V (pulse width is up 700 ns) given by SOI technology
- > Undervoltage lockout for both channels
- > 3.3 V, 5 V, and 15 V input logic compatible
- > Overcurrent protection (ITRIP $\pm 5\%$ reference)
- > Fault reporting, automatic fault clear and enable function on the same pin (RFE)
- > Matched propagation delay for all channels
- > Integrated 460 ns dead time protection
- > Shoot-through (cross-conduction) protection
- > 2.5kV HBM ESD protection

Typical application diagram

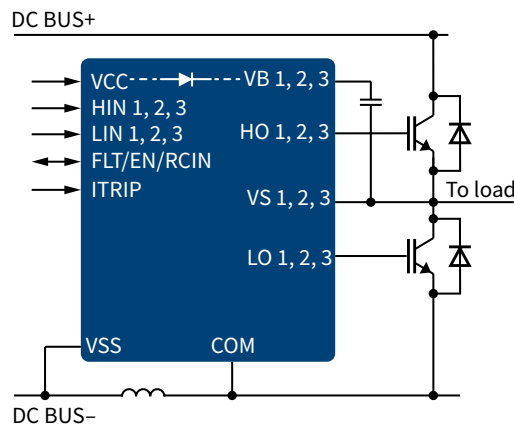

Typical applications

- > Industrial drives, motor control, general purpose inverters
- > Commercial air-conditioning (CAC)

Negative V_s transient robustness of Infineon SOI

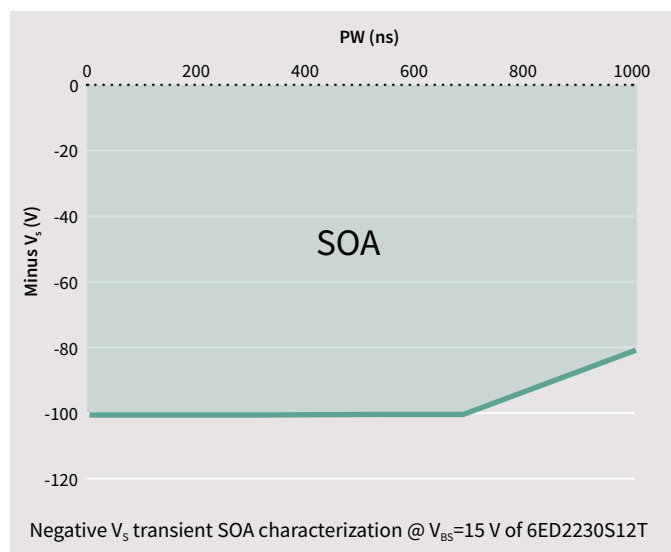

Evaluation board available:
EVAL-M1-6ED2230-B1

* Coming soon

Level-shift junction isolation (JI) gate driver ICs

New IRS200 x 200 V half-bridge, high and low-side gate driver family with V_{CC} and V_{BS} UVLO

Infineon offers 200 V ICs tailored for low-voltage (24 V, 36 V, and 48 V) and mid-voltage (60 V, 80 V, and 100 V) motor drive applications. These MOSFET drivers provide full driver capability with extremely fast switching speeds, designed-in ruggedness and low power dissipation. The 200 V driver ICs are offered in standard packages and pinout configurations with various logic input options for high design flexibility and fast time-to-market. Low side supply voltage (V_{CC}) and floating channel supply (V_{BS}) undervoltage lockout (UVLO) ensures reliable start-up operation.

Product portfolio

Part number	Voltage class [V]	Configuration	Channels	Source/sink current typ. [mA]	Deadtime typ. [ns]	Typ. propagation delay [ns]		Control inputs	UVLO typ. [V]	Package	MSL
						on	off				
IRS2008S	200	Half-bridge	2	290/600	520	680	150	IN, \overline{SD}	+8.9/-8.2	8-lead SOIC	2
IRS2007S	200	Half-bridge	2	290/600	520	160	150	HIN, \overline{LIN}	+8.9/-8.2	8-lead SOIC	2
IRS2005S	200	High- and low-side	2	290/600	-	160	150	HIN, \overline{LIN}	+8.9/-8.2	8-lead SOIC	2
IRS2005M	200	High- and low-side	2	290/600	-	160	150	HIN, \overline{LIN}	+8.9/-8.2	14-lead 4x4 MLPQ	2

IRS2005 replaces IRS2001 (IRS2001 is not recommended for new designs) / IRS2007 can replace IRS2003 / IRS2008 can replace IRS2004

Simplified application diagram

IRS2008S

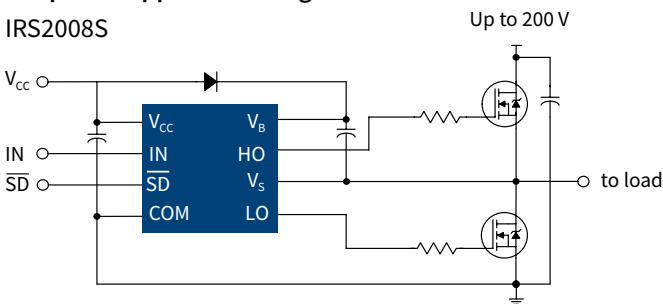

New 600 V half-bridge gate driver with overcurrent protection (OCP)

The new IRS2890DS half-bridge gate driver provides typical 0.22 A source and 0.48 A sink currents in a 14-lead SOIC package for IGBT and MOSFETs. The IRS2890DS integrates overcurrent protection, fault reporting and bootstrap FET.



Simplified application diagram

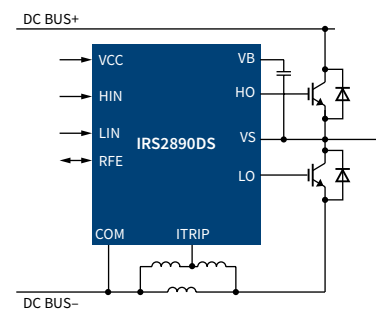

Product features
<ul style="list-style-type: none"> Advanced input filter Deadtime and cross-conduction prevention logic
<ul style="list-style-type: none"> Fully operational to +600 V offset voltage Logic operational for V_s^* of -8 V Operational for transient negative V_S -50 V with a 50 ns pulse width
<ul style="list-style-type: none"> Integrated bootstrap FET Integrated comparator (with 0.5 V \pm 5% reference) for overcurrent protection Fault and enable multifunction pin

Product benefits
<ul style="list-style-type: none"> Reliable switching Protection under abnormal operation
<ul style="list-style-type: none"> Improved reliability High power capability
<ul style="list-style-type: none"> Easy-to-use, straight-forward design Fast time-to-market BOM savings

www.infineon.com/gatedriver

*High-side floating well supply offset voltage



Non-isolated low-side gate driver ICs

1ED44176N01F - 25 V low-side gate driver with integrated overcurrent protection and fault/enable function

The 1ED44176N01F is a low-voltage, non-inverting gate driver designed for ground-referenced applications such as digitally controlled power-factor correction (PFC) circuits requiring overcurrent protection (OCP). OCP is typically implemented using a current measurement circuit with a comparator such as LM293 and a network of resistors and capacitors. 1ED44176N01F provides up to 20% cost and 50% space savings by integrating the OCP comparator, which features an accurate current-sensing threshold tolerance of $\pm 5\%$. 1ED44176N01F also integrates fault-output reporting to the controller and driver enable functionality on the same pin. The driver IC also has separate logic and power ground pins for operational robustness.

Product features

- > Overcurrent detection with positive voltage input
- > +0.8 A/-1.75 A output source/sink current capability
- > +0.5 V overcurrent threshold with $\pm 5\%$ tolerance
- > Single pin for fault output and enable function
- > Programmable fault clear time
- > CMOS Schmitt-triggered inputs
- > 3.3 V, 5 V and 15 V input logic-compatible
- > Output in phase with input
- > Separate logic and power ground
- > 2 kV ESD HBM

Potential applications

- > General purpose low-side gate driver for single-ended topologies (e.g. digitally controlled PFC or digital power supplies)
- > Residential and commercial air conditioners
- > Home appliances
- > Industrial applications



Application note, PSPICE or SiMetrix models, and evaluation board, **EVAL-1ED44176N01F** are available at www.infineon.com/1ED44176

Simplified application diagram

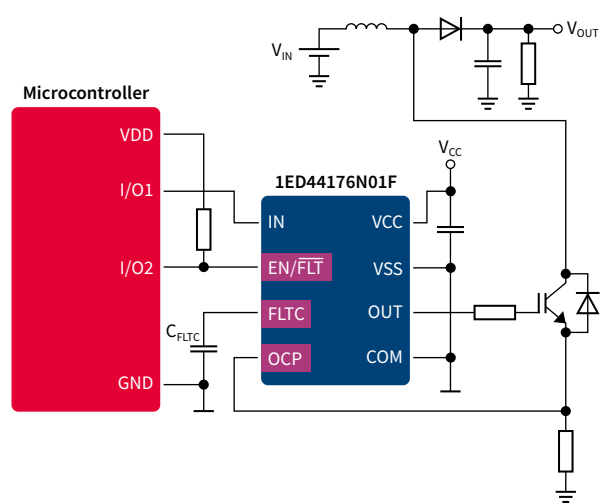

Key features
> Integrated overcurrent protection comparator with accurate OCP threshold
> Single pin for fault output and enable function
> Programmable fault clear time
> Low quiescent supply current
> Separate logic ground and gate driver return
> Undervoltage lockout (UVLO) protection

Key specifications
> 0.5 V overcurrent threshold with accurate ± 5 percent tolerance
> Internal Schmitt trigger comparator for the enable function
> External capacitor (C_{FLTC}) sets the length of the fault clear time
> Max I_{QCC} : 750 μ A
> V_{SS} and COM pins
> Specific UVLO level for IGBTs (typ. on/off = 11.9 V / 11.4 V)

System benefits
> Potential space savings up to 50 percent and cost savings up to 20 percent compared to the discrete solution
> Flexible fault clear time set-up for different microcontroller processing speeds
> Minimizes power consumption
> Avoids noise coupling from output to input which improves noise immunity
> Eliminates switching loss at low V_{cc} supply voltage

www.infineon.com/1ED44176

EiceDRIVER™ Enhanced gate driver IC family

1200 V galvanically isolated enhanced gate driver ICs



The EiceDRIVER™ 1ED Enhanced gate driver ICs are galvanic isolated single-channel IGBT and SiC MOSFET drivers in DSO-16 package that provide output current capabilities of typically 2 A. The precision DESAT function for IGBT is also an excellent solution for SiC MOSFET short-circuit protection.

All logic pins are 5 V CMOS compatible. 2ED02012-F2 is the dual-channel version of 1ED02012-F2 in DSO-36 package. 2ED02012-FI is a high voltage, high speed power MOSFET and IGBT driver with interlocking high and low side referenced outputs.

Product features

- > Available in wide body package with 8 mm creepage distance
- > Suitable for operation at high ambient temperature
- > Active miller clamp
- > Short circuit clamping and active shutdown
- > $\geq 100 \text{ kV}/\mu\text{s}$ CMTI
- > Precision DESAT protection

EiceDRIVER™ Enhanced		1ED02012-F2	2ED02012-F2	1ED02012-FT	1ED02012-B2	1ED02012-BT	2ED02012-FI
Configuration		Single	Dual	Single	Single	Single	Half Bridge
Package (all 300 mil)		DSO-16	DSO-36	DSO-16	DSO-16	DSO-16	DSO-18
Galvanic isolation		Functional	Functional	Functional	Basic (VDE 0884-10)	Basic (VDE 0884-10)	Functional on high side
Protection function		DESAT, UVLO	DESAT, UVLO	DESAT, UVLO, two-level turn-off	DESAT, UVLO	DESAT, UVLO, two-level turn-off	UVLO, OPAMP, comparator
UVLO	Input [V]	4.1/3.8	4.1/3.8	4.1/3.8	4.1/3.8	4.1/3.8	12/11
	Output [V]	12/11	12/11	12/11	12/11	12/11	12/11
DESAT charge current [μA]		500	500	500	500	500	-
Bipolar output supply		✓	✓	✓	✓	✓	-
Active miller clamp		✓	✓	✓	✓	✓	-
Inverting and non-inverting inputs		✓	✓	✓	✓	✓	-
Combinable enable/shutdown and fault feedback signals		✓	✓	✓	✓	✓	-
TLSET		-	-	✓	-	✓	-
Typical propagation delay [ns]		170	170	170 + TLTOff	170	170 + TLTOff	85
Isolation definitions							
Functional isolation		Isolation between conductive parts which is necessary only for the proper functioning of the equipment					
Basic isolation (VDE 0884-10)		Isolation applied to live parts to provide basic protection against electric shock					

Simplified application diagram

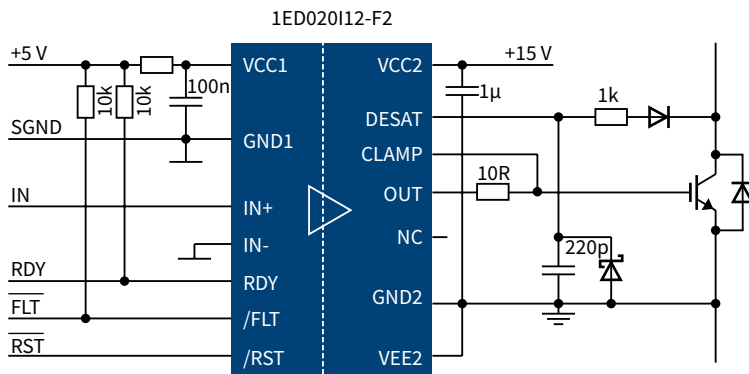

www.infineon.com/gatedriver
www.infineon.com/gdisolated



EiceDRIVER™ 1ED Compact gate driver IC family

1200 V galvanically isolated single-channel gate driver ICs



Infiniteon's new EiceDRIVER™ 1EDC Compact 300 mil family is recognized under UL 1577 with an insulation test voltage of $V_{iso} = 2500$ V(rms) for 1 min. The functional isolated EiceDRIVER™ 1EDI Compact 150 mil and 300 mil families are also available. The EiceDRIVER™ 1ED Compact family is the perfect driver for superjunction MOSFETs such as CoolMOS™, IGBTs, silicon carbide (SiC) MOSFETs such as CoolSiC™, and IGBT modules.

Product features

- › Provide DSO-8 300 mil wide body package with 8 mm creepage distance
- › Up to 10 A typical peak rail-to-rail output
- › Suitable for operation at high ambient temperature
- › Separate source and sink outputs or active miller clamp
- › More than 100 kV/μs CMTI
- › Optimized pinout for low inductance power supply



1EDI Compact 150 mil	1EDI60I12AF	1EDI40I12AF	1EDI20I12AF	1EDI05I12AF	1EDI60N12AF	1EDI20N12AF	1EDI30I12MF	1EDI20I12MF	1EDI10I12MF
1EDI Compact 300 mil	1EDI60I12AH	1EDI40I12AH	1EDI20I12AH	1EDI05I12AH	1EDI60H12AH	1EDI20H12AH	1EDI30I12MH	1EDI20I12MH	1EDI10I12MH
1EDC Compact 300 mil	1EDC60I12AH	1EDC40I12AH	1EDC20I12AH	1EDC05I12AH	1EDC60H12AH	1EDC20H12AH	1EDC30I12MH	1EDC20I12MH	1EDC10I12MH
Typ. output current [A]	10/-9.4	7.5/-6.8	4/-3.5	1.3/-0.9	10/-9.4	4/-3.5	5.9/-6.2	4.4/-4.1	2.2/-2.3
Output configuration	Separate sink/ source outputs	Separate sink/ source outputs	Separate sink/ source outputs	Separate sink/ source outputs	Separate sink/ source outputs	Separate sink/ source outputs	Active Miller clamp	Active Miller clamp	Active Miller clamp
Typ. propagation delay [ns]	300	300	300	300	125	125	300	300	300
UVLO	Input [V]	2.85/2.75	2.85/2.75	2.85/2.75	2.85/2.75	2.85/2.75	2.85/2.75	2.85/2.75	2.85/2.75
	Output [V]	12/11.1	12/11.1	12/11.1	12/11.1	12/11.1 (H) 9.1/8.5 (N)	12/11.1 (H) 9.1/8.5 (N)	11.9/11	11.9/11

Simplified application diagram

Separate sink/source outputs

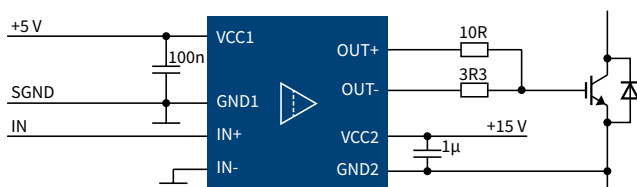

Active Miller clamp

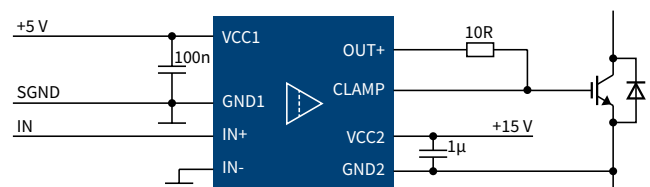

www.infineon.com/gatedriver
www.infineon.com/1EDcompact

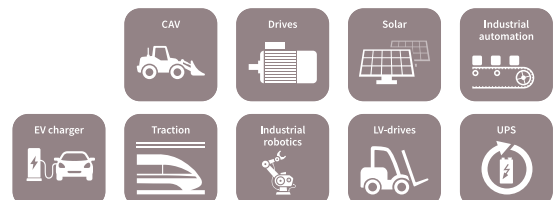

1200 V single-channel slew-rate control (SRC) gate driver family with reinforced isolation

The new SRC EiceDRIVER™ family, which includes 1EDS20I12SV, 1EDU20I12SV, and 1EDI20I12SV, is addressing the latest generation of highly efficient low-EMI electric drive systems, with lower EMI and improved efficiency. Based on the Infineon's coreless transformer technology, it is the first high voltage isolated gate driver on the market with dynamic slew-rate control (SRC), which allows on-the-fly dV/dt control of electric drives through precise gate current control, providing the best trade-off between minimum power dissipation and minimum EMI depending on operating conditions.

To turn on the IGBT, the driver works as an adjustable current source in conjunction with an external PMOS transistor and a sense resistor. To turn off the IGBT, the driver uses a 2 A MOSFET output stage. Several important and advanced protection functions are integrated. The driver includes desaturation protection for IGBTs and overcurrent protection for sense IGBTs via the fault status output pin. Two ready-state output pins indicate proper driver power supply level and normal driver operation. Two-level turn-off with adjustable timing and voltage protects against excessive overvoltage in case of the IGBT operating at overcurrent or a short circuit.

The 1EDx20I12SV family is tailored for industrial drive applications such as those using 1200 V power modules for current up to 900 A like the EconoDUAL™ 3. The driver meets today's long-term stability requirements for industrial applications. It is offered in a DSO-36 package with a package width of 300 mil. It is RoHS compliant, green, and halogen-free.

Product features

- › Real-time adjustable gate current control
- › DESAT
- › Overcurrent protection
- › Soft turn-off shut down
- › Two-level turn-off
- › Drive power modules up to 900 A
- › Drive 1200 V single-channel IGBT driver
- › Unique: NPC1 short circuit protection for three-level inverters
- › Low EMI during low load conditions and high efficiency during high load conditions
- › Reduction or elimination of dV/dt filter

Potential applications

- › AC and brushless DC motor drives
- › High-voltage DC-DC converters
- › UPS systems, servo drives



Part Number	Isolation rating
1EDS20I12SV	Reinforced isolation according VDE 0884-10 ($V_{ORM} = 1420 \text{ V}$) and UL 1577 certified with $V_{ISO} = 5 \text{ kV (rms)}$ for 1 min
1EDU20I12SV	UL 1577 certified with $V_{ISO} = 5 \text{ kV (rms)}$ for 1 min
1EDI20I12SV	Functional isolation

Evaluation board available: EVAL-1EDS20I12SV
www.infineon.com/SRC

Simplified application diagram

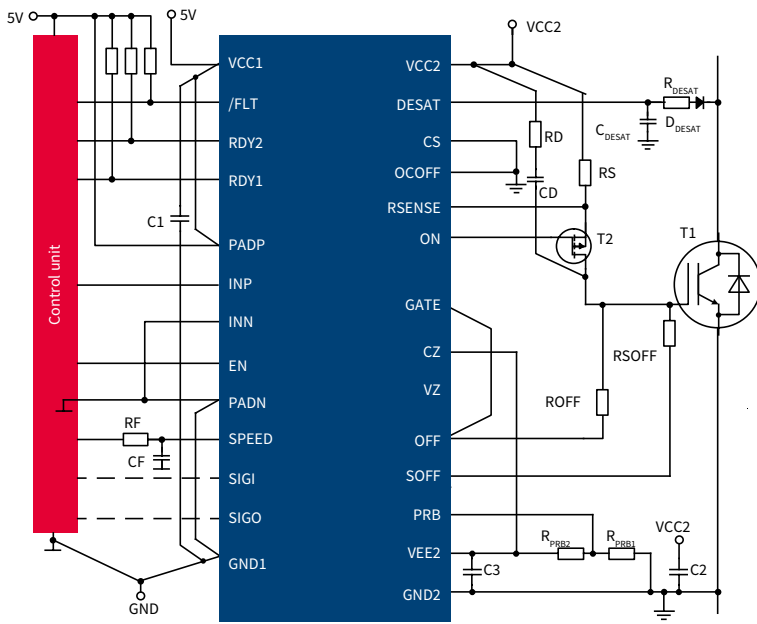

1EDS-SRC driver board with EconoDUAL™ 3 power module



Feature - real-time gate current control

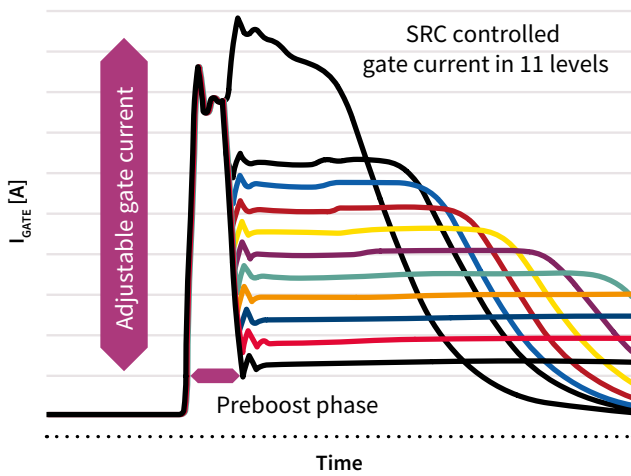

Effect - gate turn-on tunable across a very large dV/dt range:

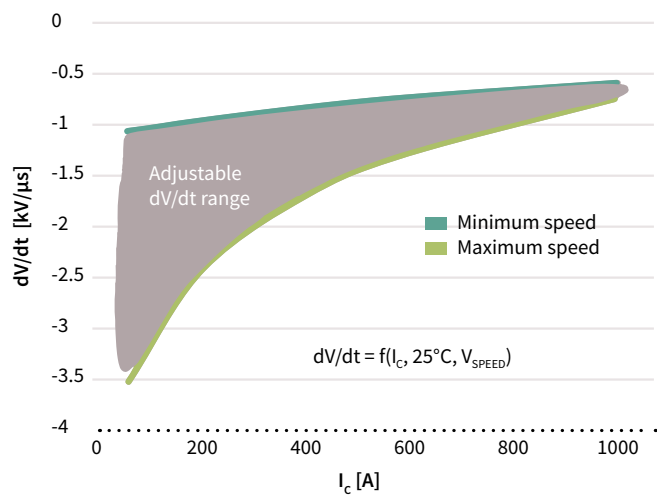

Evaluation board available: EVAL-1EDS20I12SV
www.infineon.com/SRC

Industrial and general purpose gate driver ICs

Infiniteon's gate driver IC solutions are the expert's choice. With more than 500 reliable and efficient gate driver solutions, we provide a comprehensive portfolio for virtually any application. Addressing various application requirements, Infineon delivers solutions with an assortment of gate driver topologies, voltage classes, drive capability, features and package options to optimize performance, minimize size and reduce cost. Some discrete gate driver ICs are also available in bare die. The table below shows additional gate driver IC features available in the current portfolio.

Features	Abbreviation	Benefits
Active Miller clamp	M-CLAMP	Protection against inadvertent dynamic turn-on because of parasitic Miller effects
Active shutdown	SD-ACT	Ensures a safe IGBT off-state in case the output chip is not connected to the power supply or an undervoltage lockout is in effect
Brake chopper	BRAKE	Integrated brake IGBT driver with protection
Comparator	CMP	General purpose comparator included
Current sense	CS	Senses the motor phase current through an external shunt resistor, converts from analog to digital signal, and transfers the signal to the low side
Dedicated JFET control	JFETDRIVE	Optimized to drive SiC JFET
Desaturation protection	DESAT	Protects the IGBT at short circuit
Enable	EN	Dedicated pin terminates all outputs
Fault reporting	FAULT-RPT	Indicates an overcurrent or undervoltage shutdown has occurred
Fault reset	FAULT-RST	Dedicated pin resets the DESAT-FAULT-state of the chip
High-voltage start-up	HVSTART	Provides easy and fast circuit start-up while enabling low circuit standby losses
Integrated bootstrap diode	BSD	Integrated bootstrap reduces BOM
Operational amplifier	OPAMP	An independent op-amp for current measurement or overcurrent detection
Self-oscillating (oscillator)	OSC	Integrated front end oscillator
Overcurrent protection (ITRIP)	OCP	Ensures safe application operation in case of overcurrent
Overtemperature shutdown	SD-OT	Internal overtemperature protection circuit protects the IC against excessive power loss and overheating
Programmable dead time	DT-PROG	Dead time is programmable with external resistor for flexible design
Programmable fault clear time	FLTC	The length of the fault clear time period (t_{clear}) is programmed by external capacitor which connected between FLTC and VSS (C_{FLTC}).
Programmable shutdown	SD-PROG	A shutdown feature has been designed into a pin
Separate pin for logic ground	SEP-GND	Dedicated pin or logic ground for improved noise immunity
Separate sink/source outputs	SEP-OUT	Simplifies gate resistor selection, reduces BOM, and improves dV/dt control
Shoot-through protection	STP	Additional shoot-through protection logic such as interlock
Short-circuit clamping	SC-CLAMP	During short circuit the IGBT's gate voltage tends to rise because of the feedback via the Miller capacitance. An additional protection circuit connected to OUT+ limits this voltage to a value slightly higher than the supply voltage.
Shutdown	SD	Dedicated pin disables the IC outputs
Soft overcurrent shutdown	SD-SOFT	Dedicated pin turns off the desaturated transistor, preventing overvoltages
Truly differential inputs	TDI	$\pm 70 V_{bc}$ and $\pm 150 V_{vc}$ ground-shift robustness of low-side gate driver ICs
Two-level turn-off	TLTO	Lowers VCE overshoots at turn-off during short circuits or overcurrent events
UL 1577	UL	Double galvanic isolation certification
Undervoltage lockout	UVLO	Ensures safe application operation by avoiding unexpected driver behavior at low voltages
VDE 0884-10 or VDE 0884-11	VDE	Reinforced galvanic isolation certifications for non-optical couplers

Infiniteon's industrial and general purpose gate driver ICs utilize the following technologies:

- > (1) Coreless transformer technology (CT)
- > (2) Level-shifting silicon-on-insulator technology (SOI)
- > (3) Level-shifting junction-isolation technology (JI)
- > (4) Non-isolated technology (N-ISO)

Infiniteon gate driver IC technologies

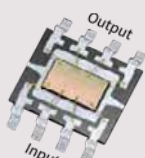
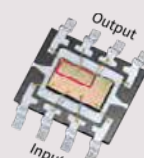
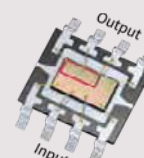
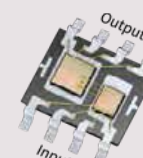
Non-isolated	Level-shift		Galvanic isolation
Low voltage	Junction isolation	Silicon on insulator	Coreless transformer
 <ul style="list-style-type: none"> > Comprehensive families of single- and dual-low-side drivers with flexible output current, logic configurations, and UVLOs > Rugged technology of the high-voltage gate drivers, and the state-of-the-art 130-nm process 	 <ul style="list-style-type: none"> > 20 years proven technology > Largest portfolio of 200 V, 600 V, 700 V and 1200 V industry standard gate drivers using rugged proprietary HVIC process 	 <ul style="list-style-type: none"> > Infiniteon SOI technology for high-voltage applications with inherent integrated bootstrap diode capability and lower level-shift losses > Industry best-in-class robustness against negative V_s transient spikes 	 <ul style="list-style-type: none"> > Magnetically-coupled isolation technology provides galvanic isolation (functional, basic and reinforced) > Strongest gate-drive output currents (up to 10 A) reducing need for external booster circuits

www.infineon.com/gatedriver

www.infineon.com/gdfinder

Dual high-side/half-bridge



Voltage class [V]	I _{OH} /I _{OL} typ. [mA]	UVLO on/off typ. [V]	Prop delay off/on typ. [ns]	Base PN	Technology	Features										Package				
						Active Miller clamp	Deadtime control	Desaturation protection	Disable	Fault reporting	Fault reset	Separate pin for logic ground	UL 1577	VDE 0884-10	DSO-16	DSO-16 WB	DSO-36 (w/o 4 pins)	TFLGA-13		
1200	2000/2000	12/11	165/170	2ED020I12-F2	CT	✓		✓			✓	✓							✓	
650	4000/8000	4.2/3.9	37 / 37	2EDF7275F	NEW CT					✓								✓		
	1000/2000			2EDF7175F	NEW CT					✓									✓	
	4000/8000	8/7		2EDS8265H	NEW CT					✓				✓					✓	
	1000/2000			2EDS8165H	NEW CT					✓				✓					✓	
250	4000/8000	4.2/3.9	2EDF7235K	NEW CT					✓										✓	
			2EDF7275K	NEW CT		✓			✓											✓

Single low-side gate driver ICs



Voltage class [V]	I _{OH} /I _{OL} typ. [mA]	UVLO on/off typ. [V]	Prop delay off/on typ. [ns]	Base PN	Technology	Features										Package				
						Automatic minimum on time protection	Enable	Fault reporting	Overcurrent protection	Programmable fault clear time	Programmable minimum on time	Separate sink/source outputs	Synchronous rectification	Truly differential inputs	DSO-8	DIP-8	SOT23-5	SOT23-6	WSON-6	
200	1000/4000	10.55/9	50/60	IR11662	N-ISO	✓	✓				✓	✓		✓						
	2000/7000	10.55/9	50/60	IR11672A	N-ISO	✓	✓				✓	✓		✓						
	1000/2500	4.5/4.4	50/50	IR1161	N-ISO	✓					✓	✓					✓			
80	4000/8000	4.2/3.9	45 / 45	1EDN7550	NEW N-ISO								✓					✓		
		8/7	45 / 45	1EDN8550	NEW N-ISO								✓					✓		
25	800/1750	11.9/11.4	50/50	1ED44176N01F	NEW N-ISO	✓	✓	✓	✓					✓						
	1500/1500	10.2/9.2	50/50	IRS44273	N-ISO													✓		
20	300/550	5/4.15	50/50	IR44252	N-ISO													✓		
		5/4.15	50/50	IR44272	N-ISO		✓											✓		
	5/4.15	50/50	IR44273	N-ISO														✓		
	4000/8000	4.2/3.9	19/19	1EDN7511	N-ISO														✓	
		8/7		1EDN8511	N-ISO														✓	
4.2/3.9		1EDN7512		N-ISO													✓		✓	
5	1600/3300	8.9/8	200/150	IR2121	N-ISO			✓	✓							✓			✓	

www.infineon.com/gatedriver
www.infineon.com/gdfinder

High-side and low-side gate driver IC



Voltage class [V]	I _o /I _o typ. [mA]	UVLO on/off typ. [V]	Prop delay off/on typ. [ns]	Base PN	Technology	Features		Package							
						Integrated bootstrap diode	Separate pin for logic ground	Shutdown	DSO-8	DSO-14	DSO-16 WB	DIP-8	DIP-14	VQFN-14	CHIP ¹
1200	2000/2500	10.2/9.3	225/280	IR2213	J1	✓	✓					✓	✓	✓	
650	290/700	9.1/8.2	200/200	2ED2106S06*	SOI	✓			✓					✓	
				2ED21064S06*	SOI	✓			✓					✓	
	2ED2181S06*			SOI	✓			✓						✓	
	2ED21814S06*			SOI	✓				✓					✓	
600	200/350	8.9/8.2	200/220	IR2106	J1			✓			✓				
		8.9/8.2		IR21064	J1		✓		✓		✓				
		4.1/3.8		IR2301	J1				✓		✓				
		8.9/8.2		IR25604	J1				✓						
		4.1/3.8		IRS2301	J1				✓						
	210/360	8.9/8.2	150/160	IR2101	J1			✓			✓		✓		
	250/500	8.6/8.2	105/125	IR2112	J1			✓			✓				
		8.6/8.2	130/135	IRS2112	J1		✓	✓			✓	✓	✓	✓	
	290/600	8.9/8.2	150/160	IRS2101	J1				✓			✓		✓	
		8.9/8.2	200/220	IRS2106	J1				✓			✓		✓	
		8.9/8.2		IRS21064	J1		✓			✓			✓		
	360/700	12.5/11.6	400/420	2EDL05I06BF	SOI	✓			✓						
	1900/2300	8.9/8.2	220/180	IRS2181	J1				✓			✓			✓
				IR2181	J1				✓			✓			
				IR21814	J1		✓			✓			✓		
				IRS21814	J1		✓			✓			✓	✓	
				IR2113	J1		✓	✓			✓		✓		✓
	2500/2500	8.6/8.2	94/120	IR25607	J1		✓	✓			✓				
		8.5/8.2	120/130	IRS2113	J1		✓	✓			✓		✓	✓	
	4000/4000	8.9/8.2	170/170	IRS2186	J1				✓			✓		✓	
8.9/8.2		IRS21864		J1		✓			✓			✓			
6/5.5		IRS21867		J1				✓							
500	2500/2500	8.6/8.2	94/120	IR2110	J1		✓	✓			✓				
		8.5/8.2	120/130	IRS2110	J1		✓	✓			✓		✓		
200	290/600	8.9/8.2	150/160	IRS2005	NEW J1				✓				✓		
		9/8.2	60/60	IRS2011	J1				✓		✓		✓		
	1000/1000	9/8.2	75/80	IR2011	J1				✓		✓				
	3000/3000	8.6/8.2	65/95	IR2010	J1		✓	✓			✓		✓		

www.infineon.com/gatedriver
www.infineon.com/gdfinder

* Coming soon
 1) Please contact sales team for additional information

Full bridge gate driver ICs



Voltage class [V]	I _o /I _o -typ. [mA]	UVLO on/off typ. [V]	Prop delay off/on typ. [ns]	Base PN	Technology	Overcurrent protection	Programmable dead time	Self-oscillating (oscillator)	Package
100	1200/1200	7.25/6.8	40/60	IR2086S	J1	✓	✓	✓	PG-DSO-16

Dual low-side gate driver ICs



Voltage class [V]	I _o /I _o -typ. [mA]	UVLO on/off typ. [V]	Prop delay off/on typ. [ns]	Base PN	Technology	Automatic minimum on time protection	Enable	Programmable minimum on time	Synchronous rectification	DSO-8	DIP-8	WSON-8	TSSOP-8	
200	1000/4000	8.1/7.6	70/60	IR1168	N-ISO	✓			✓	✓				
	1000/4000	8.1/7.6	80/100	IR11682	N-ISO	✓			✓	✓				
	1000/4000	4.55/4.35	60/250	IR11688	N-ISO	✓		✓	✓	✓				
25	2300/3300	10.2/9.2	50/50	IRS44262	N-ISO					✓				
		N.A.		IRS4426	N-ISO					✓				
				IRS4427	N-ISO						✓	✓		
		65/85	IR25600	N-ISO						✓	✓			
			IR442(6,7)	N-ISO							✓	✓		
20	5000/5000	4.2/3.9	19/19	2EDN752(3,4)	N-ISO		✓			✓		✓	✓	
		8/7		2EDN852(3,4)	N-ISO		✓			✓		✓	✓	
	4000/4000	4.2/3.9	19/19	2EDN7424	N-ISO		✓			✓			✓	

www.infineon.com/gatedriver
www.infineon.com/gdfinder

Complementary: current sense ICs



Voltage class [V]	Base PN	Technology	Current sense	Overcurrent protection	Package			
			Features	DSO-8	DSO-16 WB	DIP-8	SOT23-5	
600	IR2175	J1	✓	✓	✓		✓	
	IR25750	J1	✓					✓

Complementary: high-voltage start-up IC

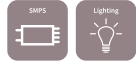

Voltage class [V]	Base PN	Technology	Enable	High voltage start-up	Overtemperature shutdown	Package
			Features			SOT23-5
480	IRS25751	N-ISO	✓	✓	✓	✓

www.infineon.com/gatedriver
www.infineon.com/gdfinder

Gate driver selection tool

To simplify the gate driver selection process, Infineon offers an online easy-to-use gate driver selection tool. By selecting a few key parameters, the tool quickly guides you in finding the right driver for your application.

Scan to find the right driver



Access the gate driver selection tool at www.infineon.com/gdfinder

For recommended gate drivers by application, visit www.infineon.com/gdapplication to download the PDF version of the gate driver application matrix.

Home Appliances

Discover the next level of power and efficiency

Infinion's gate driver ICs utilize level-shift silicon-on-insulator technology (SOI), and level-shift junction isolation technology (JI) to meet the high performance requirements in home appliance applications.

Recommended Gate Drivers	General	Air Conditioner (Residential)	Commercial Lighting	Electric Tools (Battery)	Hood Fan/Ceiling Fan/Exhaust Fan	Power Tools (AC)	Refrigerator/Washer/Dryer	Vacuum Cleaner
Home Appliances	■ IR54275 ■ IR54278L ■ IR54279	■ IR54275L ■ IR54279L ■ IR54280L	■ IR54275L ■ IR54279L ■ IR54280L	■ IR54275L ■ IR54279L ■ IR54280L	■ IR54275L ■ IR54279L ■ IR54280L	■ IR54275L ■ IR54279L ■ IR54280L	■ IR54275L ■ IR54279L ■ IR54280L	■ IR54275L ■ IR54279L ■ IR54280L
FFC	■ IR54275 ■ IR54278L ■ IR54279	■ IR54275L ■ IR54279L ■ IR54280L	■ IR54275L ■ IR54279L ■ IR54280L	■ IR54275L ■ IR54279L ■ IR54280L	■ IR54275L ■ IR54279L ■ IR54280L	■ IR54275L ■ IR54279L ■ IR54280L	■ IR54275L ■ IR54279L ■ IR54280L	■ IR54275L ■ IR54279L ■ IR54280L
SMPS	■ IR54275 ■ IR54278L ■ IR54279	■ IR54275L ■ IR54279L ■ IR54280L	■ IR54275L ■ IR54279L ■ IR54280L	■ IR54275L ■ IR54279L ■ IR54280L	■ IR54275L ■ IR54279L ■ IR54280L	■ IR54275L ■ IR54279L ■ IR54280L	■ IR54275L ■ IR54279L ■ IR54280L	■ IR54275L ■ IR54279L ■ IR54280L
DC-DC	■ IR54275 ■ IR54278L ■ IR54279	■ IR54275L ■ IR54279L ■ IR54280L	■ IR54275L ■ IR54279L ■ IR54280L	■ IR54275L ■ IR54279L ■ IR54280L	■ IR54275L ■ IR54279L ■ IR54280L	■ IR54275L ■ IR54279L ■ IR54280L	■ IR54275L ■ IR54279L ■ IR54280L	■ IR54275L ■ IR54279L ■ IR54280L
Inverter (<1 kW)	■ IR54275 ■ IR54278L ■ IR54279	■ IR54275L ■ IR54279L ■ IR54280L	■ IR54275L ■ IR54279L ■ IR54280L	■ IR54275L ■ IR54279L ■ IR54280L	■ IR54275L ■ IR54279L ■ IR54280L	■ IR54275L ■ IR54279L ■ IR54280L	■ IR54275L ■ IR54279L ■ IR54280L	■ IR54275L ■ IR54279L ■ IR54280L
Inverter (>1 kW)	■ IR54275 ■ IR54278L ■ IR54279	■ IR54275L ■ IR54279L ■ IR54280L	■ IR54275L ■ IR54279L ■ IR54280L	■ IR54275L ■ IR54279L ■ IR54280L	■ IR54275L ■ IR54279L ■ IR54280L	■ IR54275L ■ IR54279L ■ IR54280L	■ IR54275L ■ IR54279L ■ IR54280L	■ IR54275L ■ IR54279L ■ IR54280L
SR Motor Inverter	■ IR54275 ■ IR54278L ■ IR54279	■ IR54275L ■ IR54279L ■ IR54280L	■ IR54275L ■ IR54279L ■ IR54280L	■ IR54275L ■ IR54279L ■ IR54280L	■ IR54275L ■ IR54279L ■ IR54280L	■ IR54275L ■ IR54279L ■ IR54280L	■ IR54275L ■ IR54279L ■ IR54280L	■ IR54275L ■ IR54279L ■ IR54280L
Half-Bridge Topology	■ IR54275 ■ IR54278L ■ IR54279	■ IR54275L ■ IR54279L ■ IR54280L	■ IR54275L ■ IR54279L ■ IR54280L	■ IR54275L ■ IR54279L ■ IR54280L	■ IR54275L ■ IR54279L ■ IR54280L	■ IR54275L ■ IR54279L ■ IR54280L	■ IR54275L ■ IR54279L ■ IR54280L	■ IR54275L ■ IR54279L ■ IR54280L
HS-Back	■ IR54275 ■ IR54278L ■ IR54279	■ IR54275L ■ IR54279L ■ IR54280L	■ IR54275L ■ IR54279L ■ IR54280L	■ IR54275L ■ IR54279L ■ IR54280L	■ IR54275L ■ IR54279L ■ IR54280L	■ IR54275L ■ IR54279L ■ IR54280L	■ IR54275L ■ IR54279L ■ IR54280L	■ IR54275L ■ IR54279L ■ IR54280L
Sync-Back	■ IR54275 ■ IR54278L ■ IR54279	■ IR54275L ■ IR54279L ■ IR54280L	■ IR54275L ■ IR54279L ■ IR54280L	■ IR54275L ■ IR54279L ■ IR54280L	■ IR54275L ■ IR54279L ■ IR54280L	■ IR54275L ■ IR54279L ■ IR54280L	■ IR54275L ■ IR54279L ■ IR54280L	■ IR54275L ■ IR54279L ■ IR54280L

Industrial

Reliable, high quality solutions for the most rugged situations

Infinion's gate driver ICs are the expert's choice. With the breadth and depth of the portfolio, customers can quickly design and build efficient and robust systems for every industrial application.

Recommended Gate Drivers	Industrial	Air Conditioner (Commercial)	Automatic Door Opening Systems	Building Fans & Pumps	Commercial Sewing Machine	Drives	Forklift/Truck/CAV	UPS
Compressor/Fan/CAV	■ IR54275 ■ IR54278L ■ IR54279	■ IR54275L ■ IR54279L ■ IR54280L	■ IR54275L ■ IR54279L ■ IR54280L	■ IR54275L ■ IR54279L ■ IR54280L	■ IR54275L ■ IR54279L ■ IR54280L	■ IR54275L ■ IR54279L ■ IR54280L	■ IR54275L ■ IR54279L ■ IR54280L	■ IR54275L ■ IR54279L ■ IR54280L
Inverter (<5 kW)	■ IR54275 ■ IR54278L ■ IR54279	■ IR54275L ■ IR54279L ■ IR54280L	■ IR54275L ■ IR54279L ■ IR54280L	■ IR54275L ■ IR54279L ■ IR54280L	■ IR54275L ■ IR54279L ■ IR54280L	■ IR54275L ■ IR54279L ■ IR54280L	■ IR54275L ■ IR54279L ■ IR54280L	■ IR54275L ■ IR54279L ■ IR54280L
Inverter (>5 kW)	■ IR54275 ■ IR54278L ■ IR54279	■ IR54275L ■ IR54279L ■ IR54280L	■ IR54275L ■ IR54279L ■ IR54280L	■ IR54275L ■ IR54279L ■ IR54280L	■ IR54275L ■ IR54279L ■ IR54280L	■ IR54275L ■ IR54279L ■ IR54280L	■ IR54275L ■ IR54279L ■ IR54280L	■ IR54275L ■ IR54279L ■ IR54280L
Inverter (<200 kW)	■ IR54275 ■ IR54278L ■ IR54279	■ IR54275L ■ IR54279L ■ IR54280L	■ IR54275L ■ IR54279L ■ IR54280L	■ IR54275L ■ IR54279L ■ IR54280L	■ IR54275L ■ IR54279L ■ IR54280L	■ IR54275L ■ IR54279L ■ IR54280L	■ IR54275L ■ IR54279L ■ IR54280L	■ IR54275L ■ IR54279L ■ IR54280L
FFC	■ IR54275 ■ IR54278L ■ IR54279	■ IR54275L ■ IR54279L ■ IR54280L	■ IR54275L ■ IR54279L ■ IR54280L	■ IR54275L ■ IR54279L ■ IR54280L	■ IR54275L ■ IR54279L ■ IR54280L	■ IR54275L ■ IR54279L ■ IR54280L	■ IR54275L ■ IR54279L ■ IR54280L	■ IR54275L ■ IR54279L ■ IR54280L
DC-DC (1 kW - 100 kW)	■ IR54275 ■ IR54278L ■ IR54279	■ IR54275L ■ IR54279L ■ IR54280L	■ IR54275L ■ IR54279L ■ IR54280L	■ IR54275L ■ IR54279L ■ IR54280L	■ IR54275L ■ IR54279L ■ IR54280L	■ IR54275L ■ IR54279L ■ IR54280L	■ IR54275L ■ IR54279L ■ IR54280L	■ IR54275L ■ IR54279L ■ IR54280L
SMPS	■ IR54275 ■ IR54278L ■ IR54279	■ IR54275L ■ IR54279L ■ IR54280L	■ IR54275L ■ IR54279L ■ IR54280L	■ IR54275L ■ IR54279L ■ IR54280L	■ IR54275L ■ IR54279L ■ IR54280L	■ IR54275L ■ IR54279L ■ IR54280L	■ IR54275L ■ IR54279L ■ IR54280L	■ IR54275L ■ IR54279L ■ IR54280L
Brake Chopper	■ IR54275 ■ IR54278L ■ IR54279	■ IR54275L ■ IR54279L ■ IR54280L	■ IR54275L ■ IR54279L ■ IR54280L	■ IR54275L ■ IR54279L ■ IR54280L	■ IR54275L ■ IR54279L ■ IR54280L	■ IR54275L ■ IR54279L ■ IR54280L	■ IR54275L ■ IR54279L ■ IR54280L	■ IR54275L ■ IR54279L ■ IR54280L
Active Bridge Rectifier	■ IR54275 ■ IR54278L ■ IR54279	■ IR54275L ■ IR54279L ■ IR54280L	■ IR54275L ■ IR54279L ■ IR54280L	■ IR54275L ■ IR54279L ■ IR54280L	■ IR54275L ■ IR54279L ■ IR54280L	■ IR54275L ■ IR54279L ■ IR54280L	■ IR54275L ■ IR54279L ■ IR54280L	■ IR54275L ■ IR54279L ■ IR54280L

Mobility & Battery Driven

Full range of best-in-class components

From EV charger and light electric vehicle (LEV) to service robotics and drones, Infineon's family of configurable half-bridge and three-phase gate driver ICs can be combined with powerful Infineon MOSFETs to provide the required power and efficiency. Automotive-specific gate drivers qualified according to AEC-Q100 are also available.

For battery-driven applications, saving battery power is the key. Infineon offers an excellent selection of gate driver ICs providing the highest-possible energy efficiency and top precision.

Recommended Gate Drivers	Mobility & Battery Driven	EV Charger/Battery Charger	General Traction	Light Electric Vehicle (LEV)	Low Power/Industry/Service Robotics
Mobility & Battery Driven	■ IR54275 ■ IR54278L ■ IR54279	■ IR54275L ■ IR54279L ■ IR54280L	■ IR54275L ■ IR54279L ■ IR54280L	■ IR54275L ■ IR54279L ■ IR54280L	■ IR54275L ■ IR54279L ■ IR54280L
Inverter	■ IR54275 ■ IR54278L ■ IR54279	■ IR54275L ■ IR54279L ■ IR54280L	■ IR54275L ■ IR54279L ■ IR54280L	■ IR54275L ■ IR54279L ■ IR54280L	■ IR54275L ■ IR54279L ■ IR54280L
DC-DC	■ IR54275 ■ IR54278L ■ IR54279	■ IR54275L ■ IR54279L ■ IR54280L	■ IR54275L ■ IR54279L ■ IR54280L	■ IR54275L ■ IR54279L ■ IR54280L	■ IR54275L ■ IR54279L ■ IR54280L
FFC	■ IR54275 ■ IR54278L ■ IR54279	■ IR54275L ■ IR54279L ■ IR54280L	■ IR54275L ■ IR54279L ■ IR54280L	■ IR54275L ■ IR54279L ■ IR54280L	■ IR54275L ■ IR54279L ■ IR54280L
HB (LLC)	■ IR54275 ■ IR54278L ■ IR54279	■ IR54275L ■ IR54279L ■ IR54280L	■ IR54275L ■ IR54279L ■ IR54280L	■ IR54275L ■ IR54279L ■ IR54280L	■ IR54275L ■ IR54279L ■ IR54280L
Sync-Back	■ IR54275 ■ IR54278L ■ IR54279	■ IR54275L ■ IR54279L ■ IR54280L	■ IR54275L ■ IR54279L ■ IR54280L	■ IR54275L ■ IR54279L ■ IR54280L	■ IR54275L ■ IR54279L ■ IR54280L
BLDC	■ IR54275 ■ IR54278L ■ IR54279	■ IR54275L ■ IR54279L ■ IR54280L	■ IR54275L ■ IR54279L ■ IR54280L	■ IR54275L ■ IR54279L ■ IR54280L	■ IR54275L ■ IR54279L ■ IR54280L

Renewable Energy

Powering an energy-smart world

Improving efficiency is the number one objective in the field of photovoltaics. Efficiency gains of as little as one percent can still yield enormous returns in renewable energy segment.

Infinion provides a comprehensive portfolio of high-performance gate driver ICs for photovoltaic inverters. By combining EiceDRIVER™ with super-junction MOSFETs such as CoolMOS™, IGBTs, Silicon Carbide (SiC) MOSFET such as CoolSiC™, as well as IGBT and SiC modules, Infineon enables solutions that maximizing uptime and energy production.

Recommended Gate Drivers	Renewable Energy	Heat Pump	Solar Inverter
Renewable Energy	■ IR54275 ■ IR54278L ■ IR54279	■ IR54275L ■ IR54279L ■ IR54280L	■ IR54275L ■ IR54279L ■ IR54280L
Inverter (<2 kW)	■ IR54275 ■ IR54278L ■ IR54279	■ IR54275L ■ IR54279L ■ IR54280L	■ IR54275L ■ IR54279L ■ IR54280L
Inverter (>2 kW)	■ IR54275 ■ IR54278L ■ IR54279	■ IR54275L ■ IR54279L ■ IR54280L	■ IR54275L ■ IR54279L ■ IR54280L
µInverter Boost	■ IR54275 ■ IR54278L ■ IR54279	■ IR54275L ■ IR54279L ■ IR54280L	■ IR54275L ■ IR54279L ■ IR54280L
µInverter DC-AC	■ IR54275 ■ IR54278L ■ IR54279	■ IR54275L ■ IR54279L ■ IR54280L	■ IR54275L ■ IR54279L ■ IR54280L
String Boost	■ IR54275 ■ IR54278L ■ IR54279	■ IR54275L ■ IR54279L ■ IR54280L	■ IR54275L ■ IR54279L ■ IR54280L
String Inverter	■ IR54275 ■ IR54278L ■ IR54279	■ IR54275L ■ IR54279L ■ IR54280L	■ IR54275L ■ IR54279L ■ IR54280L
Central Boost/SMPS	■ IR54275 ■ IR54278L ■ IR54279	■ IR54275L ■ IR54279L ■ IR54280L	■ IR54275L ■ IR54279L ■ IR54280L
Central Inverter	■ IR54275 ■ IR54278L ■ IR54279	■ IR54275L ■ IR54279L ■ IR54280L	■ IR54275L ■ IR54279L ■ IR54280L

www.infineon.com/gatedriver
www.infineon.com/gdfinder



Infineon support for gate driver ICs

Useful links and helpful information

Further information, datasheets and documents

www.infineon.com/gatedriver

www.infineon.com/gdapplication

www.infineon.com/gdiso

www.infineon.com/ifxdesigner

www.infineon.com/crs

www.infineon.com/eicedriver

www.infineon.com/1edn

www.infineon.com/2edn

www.infineon.com/gdbrochure

www.infineon.com/gdfinder

www.infineon.com/SiC-GD

www.infineon.com/TDI

www.infineon.com/200vhvic

www.infineon.com/1EDcompact

www.infineon.com/700vhvic

www.infineon.com/microhvic

www.infineon.com/gan-eicedriver

www.infineon.com/2edi

Videos

www.infineon.com/gdvideointro

www.infineon.com/gdvideo1EDN

www.infineon.com/gdvideo2EDL

www.infineon.com/mediacenter

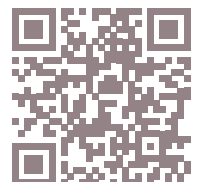

iMOTION™

Flexible and scalable platform for motor control solutions

iMOTION™ products are highly integrated devices used to control variable speed drives. By integrating both the required hardware and algorithms to perform control of permanent magnet synchronous motors (PMSM), they provide the shortest time to market for inverterized motor systems at the lowest system and development cost.

Key features

- › Ready-to-use and field-proven motor control solution
- › Various integration levels - from motor controller to SmartIPM
- › Multiple integrated protection features
- › Functional safety acc. IEC/UL 60335-1 supported

Key benefits

- › Easy to use – no motor control coding required
- › High performance and energy optimized solution
- › Reduced cost of ownership due to R&D and BOM savings
- › Fastest time to market

Our markets

- › Air conditioners
- › Home appliances
- › Fans
- › Pumps
- › Cooling compressors
- › Motor control

iMOTION™ product offering

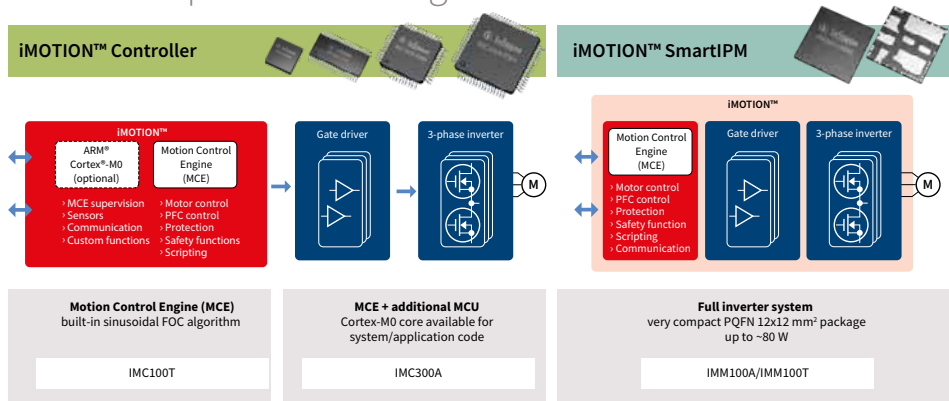

iMOTION™ ecosystem

PC tools and evaluation kits available to configure, test and fine-tune the drive inverter.

MCEWizard

SW tool to generate initial drive control parameters

MCEDesigner

SW tool to test, monitor and fine-tune the motor drive – including trace features for live monitoring the drive status

iMOTION™ Link

Isolated debug interface to iMOTION™ devices

iMOTION™ MADK Platform

Modular and scalable application kit platform for variable speed drives

Tools and software

Get the necessary software here:



www.infineon.com/iMOTION

www.infineon.com/iMOTION-software











iMOTION™ Modular Application Design Kit

Infineon's motor control evaluation platform

The iMOTION™ modular application design kit (MADK) evaluation platform covers motor drive applications up to 2 kW. The platform offers a modular and scalable system solution with different control board options and a wide range of power boards. While the M1 platform provides control of a permanent magnet synchronous motor (PMSM), the M3 platform also integrates the power factor correction (PFC) implemented as a boost or totem pole PFC.

Using the iMOTION™ MADK standardized platform interface, different control and power boards can be combined in a system that perfectly matches the requirements of the application. This modular approach allows developers the maximum flexibility and scalability during evaluation and development phase at affordable cost.

Get a motor running in less than an hour!

Motor control boards		Wide range of power boards		
M1	EVAL-M1-101T IMC101T-T038 Control card		EVAL-M1-36-84A CIPOS™ Nano-power board IRSM836-084MA ~110 V/80 W	
	EVAL-M1-099M IRMCK099 Control card		EVAL-M1-05F310 CIPOS™ Nano-power board IRSM005-310MH -100 V/300 W	
	EVAL-M1-183 IRMCF183 Control card		EVAL-M1-IM818-A CIPOS™-Maxi power board IM818-MCC -1200 V/2600 W	
	EVAL-M1-101TH IMC101T-F048 Control card			
Motor + PFC control boards		Power boards with PFC		
M3	EVAL-M3-102T IMC102T-F064 Control card		EVAL-M3-CM615PN CIPOS™ mini with boost PFC IFCM15S60GD ~220 V/800 W	
	EVAL-M3-302 IMC302A-F064 Control card		EVAL-M3-CM615TN CIPOS™ mini with totem pole PFC ICM15H60GA ~220 V/800 W	

www.infineon.com/iMOTION
www.infineon.com/MADK



XMC™

One microcontroller platform – countless solutions

Infineon's XMC™ 32-bit industrial microcontroller portfolio is designed for efficiency and demanding industrial applications.

XMC™ MCU portfolio

- > RAM: 8 kB up to 352 kB
- > Flash: 16 kB up to 2 MB
- > Accurate analog mixed-signal peripherals
- > Fast timer/PMW peripherals
- > Rich communication interfaces
- > 16-pin to 196-pin count packages

XMC1000 family

- > ARM® Cortex®-M0 up to 48 MHz
- > Peripherals up to 96 MHz
- > One-time event request unit (ERU)
- > V_{DD}: 1.8 to 5.5 V
- > T_{Ambient}: -40°C to 105°C

XMC4000 family

- > ARM® Cortex®-M4 up to 144 MHz
- > Built-in DSP, SFPU
- > Peripherals up to 144 MHz
- > Event request unit (ERU)
- > T_{Ambient}: -40°C to 125°C

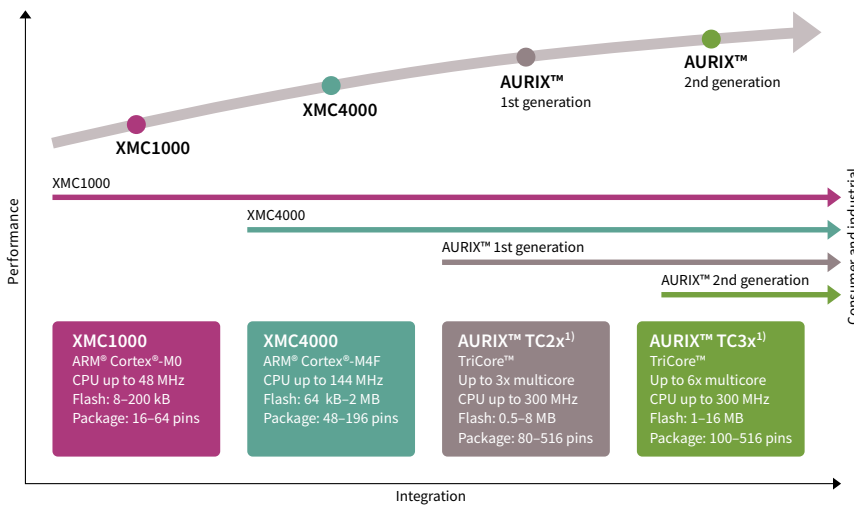

1) AURIX™ devices add safety and CAN FD



XMC4000 ARM® Cortex®-M4F up to 144 MHz core 64 kB-2 MB Flash up to 125°C	XMC4100 Basic control and connectivity VQFN-48 LQFP-64	XMC4200 Server power 150 ps HRPWM LQFP-64/100	XMC4700/4800 Industrial drives, Hall and encoder I/F, ΔΣ demodulator, LQFP-100/144 LFBGA-196	XMC4800, XMC4300 EtherCAT, +drives MultiCAN - 6 nodes LQFP-100/144 LFBGA-196
XMC1000 ARM® Cortex®-M0 up to 48 MHz core/ 96 MHz peripheral 8-200 KB flash up to 105°C 1.8-5.5 V	XMC1100 Basic control and connectivity TSSOP-16/38 VQFN-24/40	XMC1200, XMC1300 Flicker-free, 4-Ch LED, SMPS, connectivity TSSOP-16/28/38 VQFN-24, -40	XMC1400 Flicker-free, 4-Ch LED, SMPS, connectivity VQFN-40/64 LQFP-64	XMC1400 SMPS control, connectivity VQFN-40/64 LQFP-64
	XMC1400 Hall and encoder I/F, MATH co-processor, CAN VQFN-40/64 LQFP-64	XMC1400 Multi CAN - 2 nodes VQFN-48/64 LQFP-64	XMC1400 Hall and encoder I/F, MATH co-processor, TSSOP-16/38 VQFN-24/40	XMC1300 Hall and encoder I/F, MATH co-processor, TSSOP-16/38 VQFN-24/40
	XMC™ entry	LED lighting	Digital power	Motor control
				Industrial I/O



XMC™ ecosystem, enablement and partners

A comprehensive set of tools, products, components, and services are available for fast and efficient design with XMC™ microcontrollers.

Infinite enablement for XMC™ MCUs

- › **DAVE™** – www.infineon.com/dave
Professional and free-of-charge development platform
- › **XMC™ library for Embedded Coder®** – www.infineon.com/matlab
Model-based design from MATLAB® and Simulink® environment, download free of charge
- › **IEC60730 class B library for XMC™** – www.infineon.com/iec60730
Available for XMC™ industrial microcontrollers free of charge
- › **Microcontroller/Probe™ XMC™** – www.infineon.com/ucprobexmc
Free-of-charge version of microcontroller/Probe™ for XMC™ MCUs to build user interfaces for visualizing, observing, and control of the internals of XMC™ MCUs
- › **XMC™ link** – www.infineon.com/xmmlink
Functional isolated debug probe, based on SEGGER J-Link technology

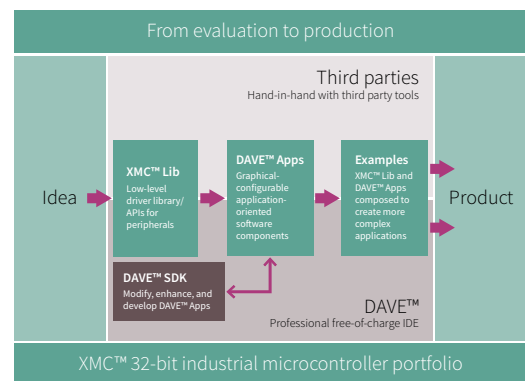

In addition to a rich third party ecosystem and enablement landscape, which support the entire development cycle from evaluation to production.

For more www.infineon.com/xmc-ecosystem



Infineon’s XMC™ 32-bit industrial microcontroller portfolio is designed for system cost and efficiency for demanding industrial applications. It comes with the most advanced peripheral set in the industry. Fast and largely autonomous peripherals can be configured to support individual needs.

Highlights include analog mixed-signal, timer/PWM and communication peripherals powered by either an ARM® Cortex®-M0 core (XMC1000 family) or a Cortex®-M4 core with a floating point unit (XMC4000 family).

ARM® Cortex®-M0	Co-processor	Clocks		Memory		Analog			Timer/PWM				Connectivity		Package
		Frequency	Peripherals	Flash	RAM	ADC1 2-bit/S&H	Number of channels	Analog comparators	CCU4 (4 ch)	CCU8 (4 ch)	POS IF	BCCU	US IC	CAN 2.0B	
XMC11x	-	32	64	Flash	8-64 kB	1/1	Up to 12	-	1x	-	-	-	2x	-	VQFN 24/40 TSSOP 16/38
				RAM	16 kB										
XMC12x	-	32	64	Flash	16-200 kB	1/2	Up to 12	Up to 3	1x	-	-	1x	2x	-	VQFN 24/40 TSSOP 16/28/38
				RAM	16 kB										
XMC13x	☑	32	64	Flash	8-200 kB	1/2	Up to 12	Up to 3	1x	1x	1x	1x	2x	-	VQFN 24/40 TSSOP 16/38
				RAM	16 kB										
XMC14x	☑	48	96	Flash	32-200 kB	1/2	Up to 12	Up to 4	2x	2x	2x	1x	4x	Up to 2	VQFN 40/48/64 LQFP 64
				RAM	16 kB										
Supply voltage range 1.8-5.5 V															
Temperature range -40°C ... 85°C/105°C															

ARM® Cortex®-M0	Frequency [MHz]	Memory		Analog			Timer/PWM					Connectivity				Package	
		Flash	RAM	ADC1 2-bit/S&H	Number of channels	DAC1 2-bit	CCU4 (4 ch)	CCU8 (4 ch)	HRPWM (150 ps)	POSIF	Σ Demodulator	US IC	CAN 2.0B	USB	Ethernet		EtherCAT®
XMC41x	80	Flash	64-128 kB	2/2	Up to 9	2 ch	2x	1x	1x	1x	-	4x	Up to 2	-	-	-	VQFN 48 TQFP 64
		RAM	20 kB														
XMC42x	80	Flash	256 kB	2/2	Up to 9	2 ch	2x	1x	4 ch	1x	-	4x	2x	1x	-	-	VQFN 48 TQFP 64
		RAM	40 kB														
XMC43x	144	Flash	256 kB	2/2	Up to 14	2 ch	2x	1x	-	-	-	4x	2x	1x	1x	1x	LQFP 100
		RAM	128 kB														
XMC44x	120	Flash	256-512 kB	4/4	Up to 18	2 ch	4x	2x	4 ch	2x	4ch	4x	2x	1x	1x	-	TQFP 64 LQFP 100
		RAM	80 kB														
XMC45x	120	Flash	512 MB	4/4	Up to 26	2 ch	4x	2x	-	2x	4 ch	4x	Up to 3	1x	1x	-	LQFP 100/144 LFBGA 144
		RAM	128-160 kB														
XMC47x	144	Flash	1.5-2 MB	4/4	Up to 26	2 ch	4x	2x	-	2x	4 ch	6x	6x	1x	1x	-	LQFP 100/144 LFBGA 196
		RAM	276-352 kB														
XMC48x	144	Flash	1-2 MB	4/4	Up to 26	2 ch	4x	2x	-	2x	4 ch	6x	6x	1x	1x	1x	LQFP 100/144 LFBGA 196
		RAM	200-352 kB														
Supply voltage range 3.1-3.6 V																	
Temperature range -40°C ... 85°C/125°C																	

www.infineon.com/xmc
www.infineon.com/dave



XMC™ digital power explorer kit

The new digital power explorer kit is designed with the particular goal of making it easy for engineers to take the first steps into digital power control with XMC™ microcontrollers. It showcases both XMC™ families Cortex®-M microcontrollers: XMC4000 and XMC1000, 30 V dual N-channel OptiMOS™ MOSFETs and IRS2011S gate drivers. The kit includes two different control card options, XMC1300 control card (ARM® Cortex®-M0) and XMC4200 control card (ARM® Cortex®-M4F), which allow designers to evaluate both XMC™ microcontroller families and make the right price/performance choice for their application.

Key features

- › Synchronous buck converter evaluation kit controlled with XMC4200 or XMC1300 ARM® Cortex®-M MCUs
- › Onboard resistive load banks
- › Featuring BSC0924NDI dual N-channel OptiMOS™ and IRS2011S high- and low-side gate driver
- › Different control schemes possible
 - Voltage mode control
 - Peak current mode control (with slope compensation)

Customer benefits

- › Easy entry in digital power control applications
- › Understand the details of voltage/peak current control and how to extract the maximum of XMC™ devices
- › DAVE™ v4 APPs for buck converter and many more examples

XMC™ digital power explorer kit	Specification		Infineon components	
	V_{in}	12 V _{DC}	MCU	XMC4200 or XMC1300
	$V_{out,nom}$	3.3 V _{DC}	MOSFETs	OptiMOS™ BSC0924NDI
	I_{out}	2 A	MOSFET half-bridge driver	IRS2011S
	P_{out}	6 W		

High power density 800 W 130 kHz platinum server design with XMC1300

The 800 W PFC CCM evaluation board demonstrates the design and practical results of an 800 W 130 kHz platinum server PFC evaluation board based on Infineon devices, in terms of power semiconductors, non-isolated gate drivers, analog and digital controllers for the PFC converter, as well as flyback controller for the auxiliary supply. This evaluation board verifies the performance of the latest 600 V CoolMOS™ C7 superjunction MOSFET technology working at 130 kHz in a PFC CCM boost converter along with EiceDRIVER™ ICs and CoolSiC™ Schottky diode 650 V G5 using digital control.

Key features

- > Classic PFC boost stage digitally controlled with XMC1302 including voltage and current loops
- > Protections, including cycle-by-cycle current protection
- > Run time debug with isolated UART to PC interface and PC software

Customer benefits

- > High efficient PFC stage with a complete system solution from Infineon
- > HW and SW available
- > Higher switching frequency permits higher power density

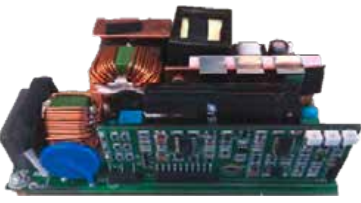
800 W PFC CCM with XMC1300	Specification		Infineon components	
	V _{in}	90-265 V _{AC}	MCU	XMC1302 (TSSOP38)
	V _{out,nom}	380 V _{DC}	MOSFET	600 V CoolMOS™ C7
	I _{out}	2 A	MOSFET driver	EiceDRIVER™ 2EDN7524F non-isolated
	PWM frequency	130 kHz	Diode	CoolSiC™ Schottky diode 650 V G5
	THD	<10%	Auxiliary PSU	ICE2QR4780Z
	Power factor	>0.9 from 20% load		
	Efficiency	97% (peak)		

600 W half-bridge LLC evaluation board with 600 V CoolMOS™ C7 SJ MOSFET with digital control

The 600 W LLC digital control evaluation board shows how to design the half-bridge LLC stage of a server SMPS with the target to meet 80+ Titanium standard efficiency requirements. For this purpose, the latest CoolMOS™ technologies, 600 V CoolMOS™ C7 or P6 superjunction MOSFETs have been used on the primary side, and OptiMOS™ low voltage power MOSFET in SuperSO8, BSC010N04LS, in the synchronous rectification secondary stage in combination with QR CoolSET™ ICE2QR2280Z, high- and low-side driver 2EDL05N06PF, low-side gate driver 2EDN7524F and a XMC4200 microcontroller.

Key features:

- > 600 W LLC half-bridge stage with synchronous rectification (SR)
- > All controlled with XMC4200 including:
 - Start up (PWM to PFM) and burst-mode algorithms
 - Adaptive dead time and capacitive-mode detection
 - No hard commutation at any condition

Customer benefits

- > Learn LLC topology with a complete system solution from Infineon
 - HW and SW available
- > Close to customer solution
 - High efficiency → 97.8%
 - Reliability and power density

600 W LLC digital control	Specification		Infineon components	
	V _{in}	350-410 V _{DC}	MCU	XMC4200 (VQFN48)
	V _{out,nom}	12 V _{DC}	MOSFET SR	BSC010N04LS
	I _{out}	50 A	HB driver	2EDL05N06PF
	P _{out}	600 W	LLC HB MOSFET	CoolMOS™ IPP60R190P6
	f _{res}	157 kHz	Auxiliary PSU	ICE2QR2280Z

www.infineon.com/xmc

www.infineon.com/800w-pfc-eval

www.infineon.com/600w-llc-eval

3 kW dual-phase LLC converter using XMC4400

The 3 kW dual-phase LLC demonstration board is an example of a high efficiency isolated DC-DC converter using the state-of-the-art Infineon components, both power devices and controller/driver ICs. The use of an advanced digital control using the XMC4400 microcontroller, together with the latest generation of CoolMOS™ and OptiMOS™ devices, allows achieving a very flat efficiency curve in the entire load range. The demonstration board is targeting the high voltage DC-DC stage of high-end telecom rectifiers.

Key features

- > Full digital control by XMC4400 on the secondary side
- > Digital current sharing with phase shedding
- > Accurate algorithm able to prevent hard commutation and capacitive load mode in LLC operation

Customer benefits

- > Full digital control by XMC4400 on the secondary side
- > Efficiency peak 98.5% and more than 97.2% in the entire load range
- > Easy monitoring and parameter setting via a graphic user interface

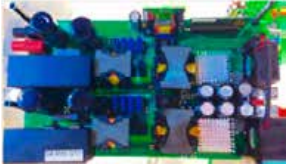
3 kW dual-phase LLC converter using XMC4400	Specification		Infineon components	
	V _{in}	350-410 V _{DC}	MCU	XMC4400 (LQFP64)
	V _{out_nom}	54.3 V _{DC}	SR MOSFET	OptiMOS™ BSC093N15NS5
	I _{out_max}	55 A	Drivers	1EDI60N12AF 2EDN7524R
	P _{out}	3000 W	LLC Half-bridge MOSFET	CoolMOS™ P6 IPW60R041P6
	f _{range}	90-200 kHz	Auxiliary PSU	ICE2QR2280Z
	Peak efficiency	>98.4%		

RGB LED lighting shield with XMC1202 for Arduino

The RGB LED lighting shield with XMC1202 for Arduino uses a DC-DC buck topology and is able to drive up to three LED channels with constant current. The shield itself is powered by a programmable XMC™ 32-bit ARM® MCU with embedded brightness color control unit (BCCU, XMC1200 MCU series), for flicker-free LED dimming and color control.

Features

- > Compatible with Arduino Uno R3 and XMC1100 boot kit from Infineon
- > Easily configurable for various light engines and any input voltage (within operating conditions)
- > Wide DC input voltage range
- > Simple I²C interface

Operating conditions

- > Nominal: 12-48 V input voltage (max. 6-60 V)
- > Average LED current up to 700 mA (max. peak current 1 A)

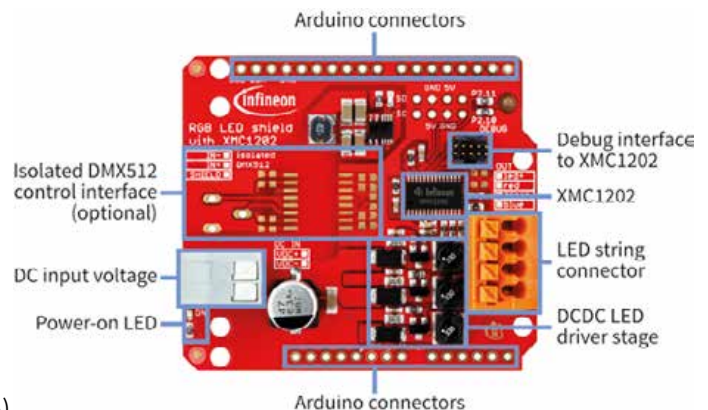

The Infineon shields mentioned above are hardware compatible with Arduino and Infineon's XMC™ boot and relax kits.

3 kW dual-phase LLC converter

XMC4800 automation board V2 – explore XMC4800 microcontroller based on ARM® Cortex®-M4

The XMC4800 automation board V2 uses Infineon's industry leading XMC™ ARM® Cortex®-M4 microcontroller in combination with Infineon's supply, interface, communication and safety products. The XMC4800 automation board V2 is designed to evaluate the capabilities of the XMC4800 microcontroller especially in EtherCAT® slave applications and can be used with a wide range of development tools including Infineon's free-of-charge Eclipse based IDE, DAVE™.

Key features

- › XMC4800-E196 MCU based on ARM® Cortex®-M4 at 144 MHz
- › EtherCAT® slave controller, 2 MB flash and 352 kB RAM
- › OPTIGA™ Trust E embedded security solution (CC EAL6+)
- › Real time clock crystal
- › SPI FRAM (64 kB non-volatile memory)
- › EtherCAT® slave node (2 EtherCAT® PHY and RJ45 Jacks)
- › 24 V ISOFACE™ 8-channel inputs and 8-channel outputs CAN transceiver
- › CAN transceiver

Customer benefits

- › Complete automation kit gateway
- › Combined MCU with EtherCAT slave application
- › Isolated interfaces with diagnose
- › Ethernet connectivity with software examples available
- › 24 V supply
- › CAN connectivity
- › Full software DAVE™ examples

XMC4800 automation board V2	Type	Description	OPN
	KIT_XMC48_AUT_BASE_V2	The XMC4800 automation board V2 utilizes Infineon's industry leading XMC ARM® Cortex®-M4 microcontroller in combination with Infineon's supply, interface/communication and safety products.	KITXMC48AUTBASEV2TOBO1
	XMC4800-E196K2048	ARM® Cortex®-M4 microcontroller	XMC4800E196K2048AAXQMA1
	ISO2H823V2.5	24 V 8-channel isolated output	ISO2H823V25XUMA1
	ISO1I813T	24 V 8-channel isolated input	ISO1I813TXUMA1
	SLS 32AIA020A4 USON10	OPTIGA™ Trust E – embedded security solution	SLS32AIA020A4USON10XTMA2
	TLE6250GV33	Infineon CAN transceiver	TLE6250GV33XUMA1
	IFX54441LDV	Infineon voltage regulator	IFX54441LDVXUMA1

XMC™ wireless power controller – enabling wireless charging transmitter applications

Infineon's XMC™ wireless power controller, based on the ARM® Cortex®-M0 core, provides a powerful and cost-effective platform for high performance, smart and safe wireless charging applications. The XMC™ wireless power controller helps the next-generation wireless charging systems to meet strict safety, environmental and regulatory requirements, while still enabling industry-leading charging performance and efficiency. This controller works seamlessly with Infineon's power devices in a scalable architecture to provide a complete charging solution for everything from a fast-charge smartphone, to a 20 W robot, or a 60 W drone and beyond.

Key features

- › Supports inductive and resonant charging methods
- › Power levels up to 60 W
- › Multiple industry standard and custom charging profiles using the same hardware architecture
- › Single- and multi-coil transmitters
- › Half- and full-bridge support
- › Variable and fixed frequency transmitter types
- › Buck and boost topologies
- › Integrated flash for parameter storage
- › Voltage supply 1.8-5.5 V
- › Space saving VQFN-40 package

Customer benefits

- › Supports 15 W charging and existing standards, including fast charging of smartphones
- › Full power 15 W without exotic thermal management
- › Achieves charging rates equivalent to wired charging
- › Supports custom-charging profiles and industry standards on the same hardware
- › Foreign object detection (FOD) with improved accuracy quality-factor monitoring
- › Foreign object detection capability can be extended beyond existing standards to improve detection
- › Supports custom coils, and greater than three coils

For a detailed overview of Infineon's wireless charging solutions, check **pages 60 to 64**.

XMC™ peripherals

IEC60730 class B library for XMC™

Supporting the XMC1xxx and XMC4xxx families



In collaboration with the consultancy Hitex, Infineon developed the IEC60730 – class B software library for XMC™ industrial microcontrollers for household electrical appliances. This is a dedicated software library for XMC™ MCUs with routines for internal supervisory functions and for self-diagnostics.

Extended documentation and pre-certified software libraries to XMC™ Cortex® ARM® based controllers are free of charge. For more information, please check: www.hitex.com/classb

Documentation	Consultancy
<ul style="list-style-type: none"> > Safety application note > Failure mode report > FMEDA tool <p>by Infineon, revised in workshops by TÜV Süd</p>	 <p>EMBEDDED TOOLS & SOLUTIONS</p> <p>Implementation support by Hitex</p>

Embedded security for XMC™ MCUs

Infineon and its partners provide solutions which support support with data protection, allowing authentication and encryption and securing firmware file updates to prevent cloning and downtimes.

Security solutions		
Software	Hardware	
Secure bootloader by Infineon, XMC1000	OPTIGA™ family by Infineon Hardware-based security solutions	
CodeMeter μEmbedded by WIBU, XMC4000 exclusive	OPTIGA™ Trust family 	OPTIGA™ TPM family 
KMS/CycurKEYS by ESCRYPT, XMC4000		
emSecure by SEGGER	Turnkey and programmable security solutions	Standardized certified turnkey solution

AURIX™ – 32-bit microcontrollers

32-bit multicore TriCore™ – safety joins performance

AURIX™ is Infineon’s family of microcontrollers serving the needs of industrial applications in terms of performance and safety. Its innovative multicore architecture, based on up to six independent 32-bit TriCore™ CPUs at 300 MHz, has been designed to meet the highest safety standards while increasing the performance at the same time. Using the AURIX™ scalable platform, developers will be able to implement applications such as motor control and drives, PLC or any other automation application. Developments using AURIX™ require less effort to achieve the SIL/ IEC61508 standard based on its innovative safety concept and multiple HW safety features. Furthermore, AURIX™ has enhanced communication capabilities to support communication between CAN, LIN, FlexRay and Ethernet buses.

Key features

- › TriCore™ with DSP functionality
- › Best-in-class real-time performance: up to six TriCore™ with up to 300 MHz per core
- › Supporting floating point and fix point with all cores
- › Up to 6.9 MB of internal RAM, up to 16 MB of flash
- › Innovative single supply 5 V or 3.3 V
- › IEC61508 conformance to support safety requirements up to SIL 3
- › Embedded EEPROM
- › Advanced communication peripherals: CAN FD, LIN, SPI, FlexRay, Ethernet

Key benefits

- › High scalability gives the best cost-performance fit
- › High integration leads to significant cost savings
- › High integration leads to reduced complexity
- › Innovative supply concept leads to best-in-class power consumption

AURIX™ family package scalability

	TQFP-80	TQFP-100	LQFP-144 TQFP-144	LQFP-176	LFBGA-292	BGA-416	LFBGA-516
9x series up to 8 MB max. SRAM 2.75 MB triple-core					TC297	TC298	TC299
7x series up to 4 MB max. SRAM 472 kB triple-core				TC275	TC277		
6x series up to 2.5 MB max. SRAM 752 kB dual-core			TC264	TC265	TC267		
3x series up to 2 MB max. SRAM 708 kB lockstep-core		TC233	TC234		TC237		
2x series up to 1 MB max. SRAM 96 kB lockstep-core	TC222	TC223	TC224				
1x series up to 512 kB max. SRAM 56 kB lockstep-core	TC212	TC213	TC214				

↑↓ Upgrade/downgrade with pin-compatible packages

www.infineon.com/aurix

AURIX™ TC2xx portfolio

Product type	Max. clock frequency [MHz]	Program memory [kB]	SRAM (incl. cache) [kB]	Co-processor ¹⁾	Cores/lockstep	Timed I/O	Number of ADC channels	External bus interface	CAN nodes	Communication interfaces ²⁾	Temperature ranges ³⁾	Packages	Additional features/remarks ⁴⁾
TC299TX	300	8000	2728	FPU	3/1	263	84/10 DS	yes	6	4xASCLIN, 6xQSPI, 3xMSC, 2xI ² C, 15xSENT, HSSL, 5xPSI5, 2xFlexRay, Ethernet, CAN FD	K	LFBGA-516	EVR, STBU, HSM
TC299TP	300	8000	728	FPU	3/1	263	84/10 DS	yes	6	4xASCLIN, 6xQSPI, 3xMSC, 2xI ² C, 15xSENT, HSSL, 5xPSI5, 2xFlexRay, Ethernet, CAN FD	K	LFBGA-516	EVR, STBU, HSM
TC298TP	300	8000	728	FPU	3/1	232	60/10 DS	yes	6	4xASCLIN, 6xQSPI, 3xMSC, 2xI ² C, 15xSENT, HSSL, 5xPSI5, 2xFlexRay, Ethernet, CAN FD	K	LFBGA-416	EVR, STBU, HSM
TC297TA	300	8000	2728	FPU, FFT, CIF	3/1	169	60/10 DS	no	6	4xASCLIN, 4xQSPI, 3xMSC, 2xI ² C, 15xSENT, HSSL, 5xPSI5, 2xFlexRay, Ethernet, CAN FD	K	LFBGA-292	EVR, STBU, HSM
TC297TX	300	8000	2728	FPU	3/1	263	60/10 DS	no	6	4xASCLIN, 4xQSPI, 3xMSC, 2xI ² C, 15xSENT, HSSL, 5xPSI5, 2xFlexRay, Ethernet, CAN FD	K	LFBGA-292	EVR, STBU, HSM
TC297TP	300	8000	728	FPU	3/1	169	60/10 DS	no	6	4xASCLIN, 4xQSPI, 3xMSC, 2xI ² C, 15xSENT, HSSL, 5xPSI5, 2xFlexRay, Ethernet, CAN FD	K	LFBGA-292	EVR, STBU, HSM
TC277TP	200	4000	472	FPU	3/2	169	60/6 DS	no	4	4xASCLIN, 4xQSPI, 2xMSC, HSSL, 2xI ² C, 10xSENT, 3xPSI5, FlexRay, Ethernet, CAN FD	K	LFBGA-292	EVR, WUT, HSM
TC275TP	200	4000	472	FPU	3/2	112	60/6 DS	no	4	4xASCLIN, 4xQSPI, 2xMSC, HSSL, 2xI ² C, 10xSENT, 3xPSI5, FlexRay, Ethernet, CAN FD	K	LQFP-176	EVR, WUT, HSM
TC267D	200	2500	240	FPU	2/1	169	50/3 DS	no	5	4xASCLIN, 4xQSPI, 2xMSC, 2xI ² C, 10xSENT, HSSL, 3xPSI5, FlexRay, Ethernet, CAN FD	K	LFBGA-292	EVR, STBU
TC265D	200	2500	240	FPU	2/1	112	50/3 DS	no	5	4xASCLIN, 4xQSPI, 2xMSC, 2xI ² C, 10xSENT, HSSL, 3xPSI5, FlexRay, Ethernet, CAN FD	K	LQFP-176	EVR, STBU
TC264DA	200	2500	752	FPU, FFT, CIF	2/1	88	40/3 DS	no	5	4xASCLIN, 4xQSPI, 2xMSC, 2xI ² C, 10xSENT, HSSL, 3xPSI5, FlexRay, Ethernet, CAN FD	K	LQFP-144	EVR, STBU
TC264D	200	2500	240	FPU	2/1	88	40/3 DS	no	5	4xASCLIN, 4xQSPI, 2xMSC, 2xI ² C, 10xSENT, HSSL, 3xPSI5, FlexRay, Ethernet, CAN FD	K	LQFP-144	EVR, STBU
TC237LP	200	2000	192	FPU	1/1	120	24	no	6	2xASCLIN, 4xQSPI, 4xSENT, FlexRay, CAN FD	K	LFBGA-292	EVR, WUT, HSM
TC234LA	200	2000	704	FPU, FFT	1/1	120	24	no	6	2xASCLIN, 4xQSPI, 4xSENT, FlexRay, Ethernet	K	TQFP-144	EVR, WUT, HSM
TC234LX	200	2000	704	FPU	1/1	120	24	no	6	2xASCLIN, 4xQSPI, 4xSENT, FlexRay, Ethernet	K	TQFP-144	EVR, WUT, HSM
TC234LP	200	2000	192	FPU	1/1	120	24	no	6	2xASCLIN, 4xQSPI, 4xSENT, FlexRay, CAN FD	K	TQFP-144	EVR, WUT, HSM
TC233LP	200	2000	192	FPU	1/1	78	24	no	6	2xASCLIN, 4xQSPI, 4xSENT, FlexRay, CAN FD	K	TQFP-100	EVR, WUT, HSM
TC224L	133	1000	96	FPU	1/1	120	24	no	3	2xASCLIN, 4xQSPI, 4xSENT, CAN FD	K	TQFP-144	EVR, WUT
TC223L	133	1000	96	FPU	1/1	78	24	no	3	2xASCLIN, 4xQSPI, 4xSENT, CAN FD	K	TQFP-100	EVR, WUT
TC222L	133	1000	96	FPU	1/1	59	24	no	3	2xASCLIN, 4xQSPI, 4xSENT, CAN FD	K	TQFP-80	EVR, WUT
TC214L	133	500	96	FPU	1/1	120	14	no	3	2xASCLIN, 4xQSPI, 4xSENT, CAN FD	K	TQFP-144	EVR, WUT
TC213L	133	500	96	FPU	1/1	78	24	no	3	2xASCLIN, 4xQSPI, 4xSENT, CAN FD	K	TQFP-100	EVR, WUT
TC212L	133	500	96	FPU	1/1	59	24	no	3	2xASCLIN, 4xQSPI, 4xSENT, CAN FD	K	TQFP-80	EVR, WUT

¹⁾ CIF = camera and external ADC Interface, FFT = fast fourier transform accelerator, FPU = floating point unit, PCP = peripheral control processor
²⁾ ASC = asynchronous serial channel, ASCLIN = asyn/synchronous local interconnect network, HSSL= high-speed serial link, I²C = inter-integrated circuit, LIN = local interconnect network, MLI = micro link interface, MSC = micro second channel, PSI5 = peripheral sensor interface 5, QSPI = queued serial peripheral interface, SENT = single edge nibble transmission, SSC = synchronous serial channel, CAN FD ISO11898-1:2015
³⁾ Ambient temperature range: A = -40°C ... 140°C, B = 0°C ... 70°C, F = -40°C ... 85°C, H = -40°C ... 110°C, K = -40°C ... 125°C, L = -40°C ... 150°C, X = -40°C ... 105°C
⁴⁾ EVR = embedded voltage regulator, HSM = hardware security module, STBU = stand-by control unit, WUT = wake-up timer

AURIX™ 2nd generation – TC3xx

AURIX™ TC3xx architecture evolution from TC2xx to TC3xx

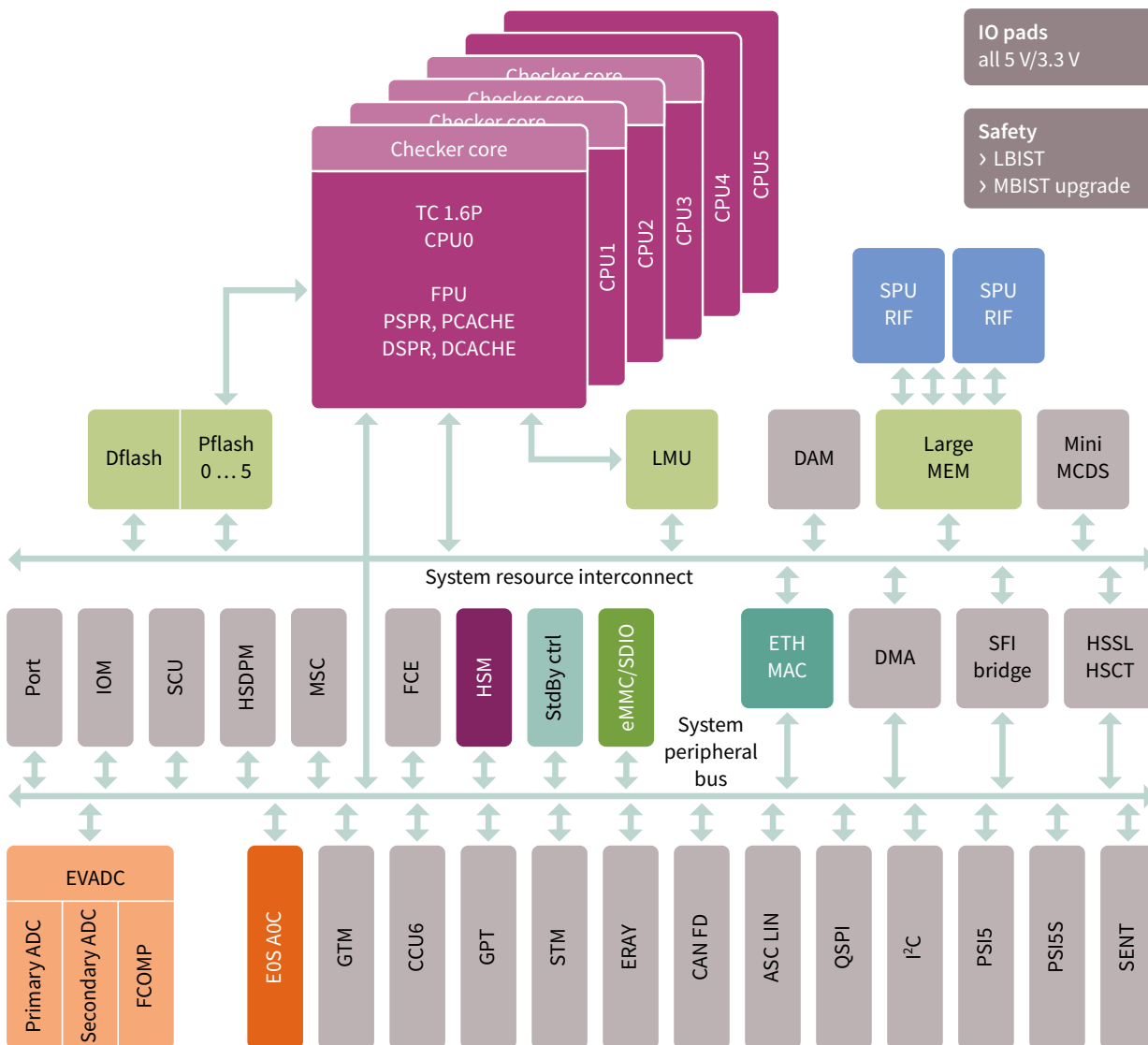

- Performance**
 - > New TriCore™ 162 generation
 - > New instructions
 - > Up to 6 CPUs at 300 MHz
 - > New direct flash access path

- HSM: full EVITA compliance**
 - > New accelerators ECC256/SHA256
 - > Available on all devices

- ADAS**
 - > New HW accelerator concept - SPU (signal processing unit)

- ADC**
 - > Improvement of existing ADC
 - > Reduction of capacitive load

- Delta-sigma**
 - > Enhanced concept

- Memories**
 - > Larger SRAM
 - > SRAM/flash ratio increased
 - > Enhanced MPU

- Stand-by control unit**
 - > Low-power modes

- Ethernet**
 - > 1 Gbit/s ETH
 - > QoS services
 - > Remote DMA

- eMMC/SDIO**
 - > External NAND flash IF

AURIX™ TC3xx package scalability

9x series up to 16 MB						TC397Xx TC397Qx 300 MHz	TC399Xx 300 MHz
8x series up to 12 MB						TC387Qx 300 MHz	
8x series up to 10 MB						TC387Q 300 MHz	TC389Q 300 MHz
7x A series up to 6 MB						TC377TX 300 MHz	
7x series up to 6 MB					TC375T 300 MHz	TC377T 300 MHz	
6x series up to 4 MB			TC364D 300 MHz	TC365D 300 MHz	TC366D 300 MHz	TC367D 300 MHz	
5x A series up to 4 MB				TC356TA 300 MHz		TC357TA 300 MHz	
3x A series up to 2 MB				TC336DA 200 MHz		TC337DA 200 MHz	
3x series up to 2 MB	TC332L 200 MHz	TC333L 200 MHz	TC334L 200 MHz	TC336L 200 MHz		TC337L 200 MHz	
2x series up to 1 MB	TC322L 160 MHz	TC323L 160 MHz	TC324L 160 MHz			TC327L 160 MHz	
Flash Package	TQFP-80	TQFP-100	T/LQFP-144	LQFP-176	LFBGA-196	LFBGA-292	LFBGA-516

L – Single lockstep core D – Dual core T – Triple core Q – Quadruple core X – Sextuple core



- › Advanced package technologies deliver the best price/performance ratio
- › Customers can choose between different devices in the same pin-compatible package

MCU scalability

- › Performance and flash
- › Pin compatibility
- › Binary-compatible cores

Safety/security concept

- › ISO 26262 compliance
- › Hardware security support
- › IEC61508 compliant

AURIX™ TC3xx

Power consumption

- › On-chip SC DC-DC high-efficiency power supply
- › Integrated standby controller

Connectivity

- › Ethernet: up to 2x1 GB
- › CAN FD: up to 12 channels
- › LIN: up to 24 channels
- › eMMC IF

TriCore™ microcontroller portfolio

Product type	Cores/lockstep	Max clock frequency [MHz]	Program memory [kB]	SRAM (incl. cache) [kB]	Radar accelerator/ radar interface ¹⁾	CAN/CAN FD nodes	Ethernet 100/1000 Mbit	External bus interface ²⁾	Communication interfaces	HSM	Temperature ranges	Packages	Additional features/ remarks ³⁾
AURIX™ TC3xx family													
TC399XX	6/4	300	16000	6912	no	12	1	EBU, eMMC, 2x HSSL	6x SPI, 2x FlexRay, 12x LIN, 25x SENT, 4x PSI5, 2x I ² C, 4x MSC	EVITA full	K, L	LFBGA-516	5 V/3.3 V EVR, 8-bit SCR
TC399XP	6/4	300	16000	2816	no	12	1	EBU, eMMC, 2x HSSL	6x SPI, 2x FlexRay, 12x LIN, 25x SENT, 4x PSI5, 2x I ² C, 4x MSC	EVITA full	K, L	LFBGA-516	5 V/3.3 V EVR, 8-bit SCR
TC397XX	6/4	300	16000	6912	no	12	1	eMMC, 2x HSSL	6x SPI, 2x FlexRay, 12x LIN, 25x SENT, 4x PSI5, 2x I ² C, 4x MSC	EVITA full	K, L	LFBGA-292	5 V/3.3 V EVR, 8-bit SCR
TC397XP	6/4	300	16000	2816	no	12	1	eMMC, 2x HSSL	6x SPI, 2x FlexRay, 12x LIN, 25x SENT, 4x PSI5, 2x I ² C, 4x MSC	EVITA full	K, L	LFBGA-292	5 V/3.3 V EVR, 8-bit SCR
TC397XA	6/4	300	16000	6912	2x SPU/ 8x 400 Mbit/s LVDS	12	1	2x HSSL	6x SPI, 2x FlexRay, 12x LIN, 25x SENT, 4x PSI5, 2x I ² C, 4x MSC	EVITA full	K, L	LFBGA-292	5 V/3.3 V EVR, 8-bit SCR
TC389QP	4/2	300	10000	1568	no	12	1	HSSL	5x SPI, 2x FlexRay, 24x LIN, 25x SENT, 4x PSI5, 2x I ² C, 3x MSC	EVITA full	K, L	LFBGA-516	5 V/3.3 V EVR, 8-bit SCR
TC387QP	4/2	300	10000	1568	no	12	1	HSSL	5x SPI, 2x FlexRay, 24x LIN, 25x SENT, 4x PSI5, 2x I ² C, 3x MSC	EVITA full	K, L	LFBGA-292	5 V/3.3 V EVR, 8-bit SCR
TC377TX	3/3	300	6000	4208	no	12	2	eMMC, HSSL	5x SPI, 1x FlexRay, 12x LIN, 15x SENT, 2x PSI5, 1x I ² C, 2x MSC	EVITA full	K, L	LFBGA-292	5 V/3.3 V EVR, 8-bit SCR
TC377TP	3/2	300	6000	1136	no	8	1	HSSL	5x SPI, 1x FlexRay, 12x LIN, 15x SENT, 2x PSI5, 1x I ² C, 2x MSC	EVITA full	K, L	LFBGA-292	5 V/3.3 V EVR, 8-bit SCR
TC375TP	3/2	300	6000	1136	no	8	1	HSSL	5x SPI, 1x FlexRay, 12x LIN, 15x SENT, 2x PSI5, 1x I ² C, 2x MSC	EVITA full	K, L	LQFP-176	5 V/3.3 V EVR, 8-bit SCR
TC367DP	2/2	300	4000	672	no	8	1	HSSL	4x SPI, 1x FlexRay, 12x LIN, 10x SENT, 2x PSI5, 1x I ² C, 1x MSC	EVITA full	K, L	LFBGA-292	5 V/3.3 V EVR, 8-bit SCR
TC366DP	2/2	300	4000	672	no	8	1	HSSL	4x SPI, 1x FlexRay, 12x LIN, 10x SENT, 2x PSI5, 1x I ² C, 1x MSC	EVITA full	K, L	LFBGA-196	5 V/3.3 V EVR, 8-bit SCR
TC365DP	2/2	300	4000	672	no	8	1	HSSL	4x SPI, 1x FlexRay, 12x LIN, 10x SENT, 2x PSI5, 1x I ² C, 1x MSC	EVITA full	K, L	LQFP-176	5 V/3.3 V EVR, 8-bit SCR
TC364DP	2/2	300	4000	672	no	8	1	HSSL	4x SPI, 1x FlexRay, 12x LIN, 10x SENT, 2x PSI5, 1x I ² C, 1x MSC	EVITA full	K, L	TQFP-144	5 V/3.3 V EVR, 8-bit SCR
TC364DP	2/2	300	4000	672	no	8	1	HSSL	4x SPI, 1x FlexRay, 12x LIN, 10x SENT, 2x PSI5, 1x I ² C, 1x MSC	EVITA full	K, L	LQFP-144	5 V/3.3 V EVR, 8-bit SCR
TC357TA	3/2	300	4000	3664	2x SPU/ 8x 400 Mbit/s LVDS	8	1	no	4x SPI, 1x FlexRay, 4x LIN	EVITA full	K, L	LFBGA-292	5 V/3.3 V EVR, 8-bit SCR
TC356TA	3/2	300	4000	3664	2x SPU/ 8x 400 Mbit/s LVDS	8	1	no	4x SPI, 1x FlexRay, 4x LIN	EVITA full	K, L	LFBGA-196	5 V/3.3 V EVR, 8-bit SCR
TC337DA	2/1	200	2000	1568	1x SPU/ 4x 400 Mbit/s LVDS	8	1	eMMC	4x SPI, 1x FlexRay, 12x LIN, 6x SENT	EVITA full	K, L	LFBGA-292	5 V/3.3 V EVR, 8-bit SCR
TC336DA	2/1	200	2000	1568	1x SPU/ 4x 400 Mbit/s LVDS	8	1	eMMC	4x SPI, 1x FlexRay, 12x LIN, 6x SENT	EVITA full	K, L	LFBGA-196	5 V/3.3 V EVR, 8-bit SCR
TC337LP	1/1	200	2000	248	no	8	no	no	4x SPI, 1x FlexRay, 12x LIN, 6x SENT	EVITA full	K, L	LFBGA-292	5 V/3.3 V EVR, 8-bit SCR
TC336LP	1/1	200	2000	248	no	8	no	no	4x SPI, 1x FlexRay, 12x LIN, 6x SENT	EVITA full	K, L	LFBGA-196	5 V/3.3 V EVR, 8-bit SCR
TC334LP	1/1	200	2000	248	no	8	no	no	4x SPI, 1x FlexRay, 12x LIN, 6x SENT	EVITA full	K, L	TQFP-144	5 V/3.3 V EVR, 8-bit SCR
TC333LP	1/1	200	2000	248	no	8	no	no	4x SPI, 1x FlexRay, 12x LIN, 6x SENT	EVITA full	K, L	TQFP-100	5 V/3.3 V EVR, 8-bit SCR
TC332LP	1/1	200	2000	248	no	8	no	no	4x SPI, 1x FlexRay, 12x LIN, 6x SENT	EVITA full	K, L	TQFP-80	5 V/3.3 V EVR, 8-bit SCR
TC327LP	1/1	160	1000	96	no	8	no	no	4x SPI, 6x SENT, 6x LIN	EVITA full	K, L	LFBGA-292	5 V/3.3 V EVR, 8-bit SCR
TC324LP	1/1	160	1000	96	no	8	no	no	4x SPI, 6x SENT, 6x LIN	EVITA full	K, L	TQFP-144	5 V/3.3 V EVR, 8-bit SCR
TC323LP	1/1	160	1000	96	no	8	no	no	4x SPI, 6x SENT, 6x LIN	EVITA full	K, L	TQFP-100	5 V/3.3 V EVR, 8-bit SCR
TC322LP	1/1	160	1000	96	no	8	no	no	4x SPI, 6x SENT, 6x LIN	EVITA full	K, L	TQFP-80	5 V/3.3 V EVR, 8-bit SCR

1) SPU – Signal processing unit
 2) HSSL – High-speed serial link
 3) 8-bit SCR – Standby controller for low power modes
 4) EVR – Embedded voltage regulator

AURIX™ starter and application kits

Infiniteon starter kits – 32-bit microcontrollers

TriBoards

Infiniteon TriCore™ family starter kits are powerful evaluation systems that enable evaluation and development well before the target hardware is available. They offer a solid platform for both hardware and software engineers to evaluate and prototype designs that are closely aligned with their final applications.

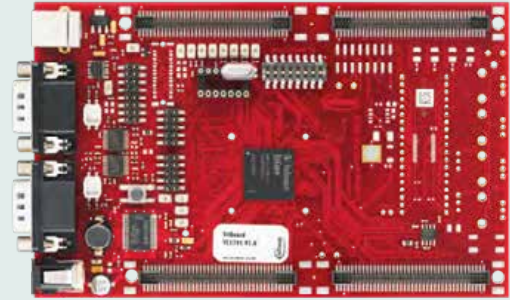

Application kits

To simplify the development of your own application, the kit comes with a variety of onboard components, including a highly integrated software development environment that gives you everything you need to compile, debug, and flash your AURIX™ multicore application, such as radar, Arduino, gateway and safety.

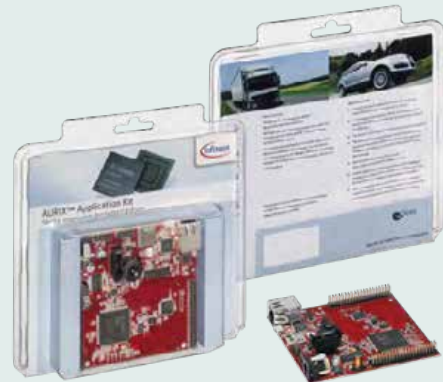

System application kits

The system application kits provide a quick jump-start to typical microcontroller applications, such as motor control, radar etc. These reference design kits enable faster design-in support for end applications by providing a reference board, application software, tooling and documentation.



ACT- AURIX™ configuration tool

ACT is a powerful tool that helps engineers to jump-start the programming of Infineon microcontrollers.

Key feature

- > Altium TASKING VX TriCore™ lite version including built-in
 - AURIX™ pin mapping incl. interactive package view
 - AURIX™ iLLD (low-level driver)
 - AURIX™ OSEK

For further information on TriCore™ tools, visit www.infineon.com/aurix-tools

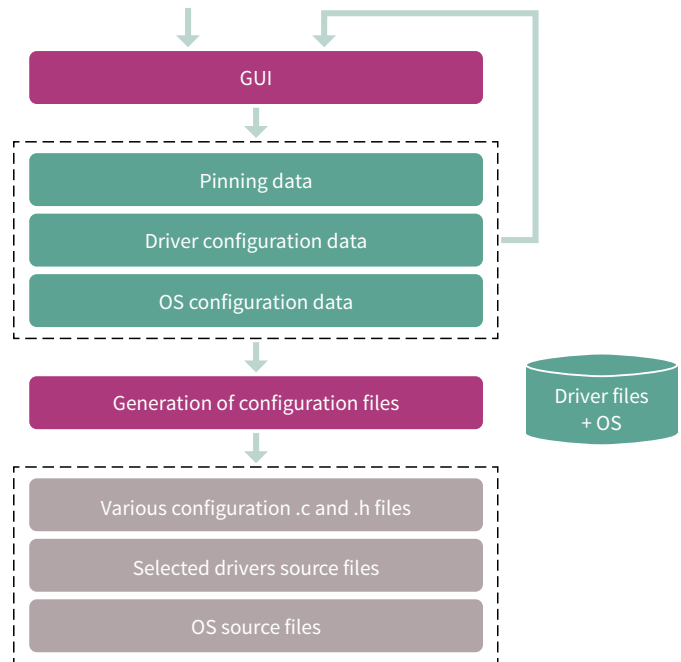

Free TriCore™ entry tool chain

This free-of-charge entry tool chain provides all the features required to develop and test software for TriCore™ and AURIX™. The tool can be used with all available TriCore™ and AURIX™ starter kits and application boards.

Key features

- > Eclipse-based IDE
- > Project wizard to easily define the project properties for device and board support
- > High-performance GNU C compiler
- > Integrated source-level debugger
- > On-chip flash programming support

For further information on TriCore™ tools, visit www.infineon.com/aurix-tools

AURIX™ and XMC™ PDH partners

Preferred Design Houses (PDH) and software resellers

Optimized open market customer support set up for systems using AURIX™ and XMC™, including software and other Infineon's products, such as power products, sensor products and modules. Our partners are trained to use AURIX™ and XMC™.

<p style="text-align: center;">Classic (Free of charge)</p>	<ul style="list-style-type: none"> › 1st level customer support covering Infineon products/solutions › Technical interface and support to the customer 	<ul style="list-style-type: none"> › Driving design at customer › Basic training for design teams at customer › 24 h response time to the customer
<p style="text-align: center;">Premium (Consultancy mode)</p> <p>To be agreed between customers and PDH</p>	<ul style="list-style-type: none"> › Project management and project-specific application support › Specification of general software architecture, defining required layers, control and data flow structure etc. › Specification and implementation of custom device drivers › Optimization of software components with regard to speed/code size 	<ul style="list-style-type: none"> › Software testing › Support for project-specific functional safety engineering › Project-specific support for security solution › Safety support › Security support › Multicore support

Optimized regional and application-specific presence

Support capabilities	EMEA																		
	ALCANTARA	AME	HIHTEC	enice	hitec	SST	FROBAS	MIXED MODE	ROM GROUP	MicroTrack	driveexpert	ULMA	Autogramma	Embedded Office	GRINN	IAU	STUBBART	STUBBART	
Autosar	●	●	●	●	●	●	●	●	●	●	●	●	●	●	●	●	●	●	●
Motor control	●	●	●	●	●	●	●	●	●	●	●	●	●	●	●	●	●	●	●
Lighting	●	●	●	●	●	●	●	●	●	●	●	●	●	●	●	●	●	●	●
PFC/power conversion	●	●	●	●	●	●	●	●	●	●	●	●	●	●	●	●	●	●	●
AURIX™ general support HW	●	●	●	●	●	●	●	●	●	●	●	●	●	●	●	●	●	●	●
AURIX™ general support SW	●	●	●	●	●	●	●	●	●	●	●	●	●	●	●	●	●	●	●
Safety support IEC61508	●	●	●	●	●	●	●	●	●	●	●	●	●	●	●	●	●	●	●
Safety support ISO26262	●	●	●	●	●	●	●	●	●	●	●	●	●	●	●	●	●	●	●
Security support/SHE+	●	●	●	●	●	●	●	●	●	●	●	●	●	●	●	●	●	●	●
XMC™ general support HW	●	●	●	●	●	●	●	●	●	●	●	●	●	●	●	●	●	●	●
XMC™ general support SW	●	●	●	●	●	●	●	●	●	●	●	●	●	●	●	●	●	●	●
Class B certification	●	●	●	●	●	●	●	●	●	●	●	●	●	●	●	●	●	●	●
Capacitive sensing with XMC™	●	●	●	●	●	●	●	●	●	●	●	●	●	●	●	●	●	●	●
Secure boot for XMC™	●	●	●	●	●	●	●	●	●	●	●	●	●	●	●	●	●	●	●
24 GHz radar																		●	●
77 GHz radar																		●	●

Support capabilities	Americas				China
	HELLMUTH	DO Engineering	ETA	EWID	GAO
Autosar	●	●	●	●	●
Motor control	●	●	●	●	●
Lighting	●	●	●	●	●
PFC/power conversion	●	●	●	●	●
AURIX™ general support HW	●	●	●	●	●
AURIX™ general support SW	●	●	●	●	●
Safety support IEC61508	●	●	●	●	●
Safety support ISO26262	●	●	●	●	●
Security support/SHE+	●	●	●	●	●
XMC™ general support HW	●	●	●	●	●
XMC™ general support SW	●	●	●	●	●
Class B certification	●	●	●	●	●
Capacitive sensing with XMC™	●	●	●	●	●
Secure boot for XMC™	●	●	●	●	●
24 GHz radar			●		●
77 GHz radar			●		●

- Basic** ●
Essential principles and elementary know-how to support a customer; provision of basic training for design teams
- Advanced** ●
High-level project-specific application support/consulting
- Expert** ●
Extensive knowledge and ability to fully support development

www.infineon.com/aurix



Infineon support for industrial microcontrollers

One platform, countless solutions



Further information, datasheets and documents

- www.infineon.com/xmc
- www.infineon.com/xmc1000
- www.infineon.com/xmc4000
- www.infineon.com/aurix
- www.infineon.com/makers

Videos

www.infineon.com/xmc-mediacenter

XMC SC Wireless power controller:

www.infineon.com/xmcsewirelesspowercontrollers

XMC™ MCUs ecosystem and enablement – kits, board, tools and software

Boards and kits:

- www.infineon.com/xmc-dev
- www.infineon.com/connectivitykit
- www.infineon.com/ethercat

Ecosystem and tools:

www.infineon.com/xmc-ecosystem

DAVE™ IDE:

www.infineon.com/dave





Infineon XENSIV™ – sensing the world

Infineon XENSIV™ sensors are exceptionally precise thanks to industry-leading technologies. They are the perfect fit for various customer applications in automotive, industrial and consumer markets.

From the world leader in sensing technology, XENSIV™ sensors simplify lives by enabling “things” to “see”, “hear”, “feel” and intuitively “understand” their environment. As a result of proven quality and outstanding reliability, customers can rely on XENSIV™ for system stability, durability and integrity. Providing high accuracy and best-in-class measurement performance, XENSIV™ sensors add great value to customer applications. More than 40 years’ experience in sensing solutions and a deep-rooted system understanding result in the broadest portfolio of ready-to-use sensor solutions on the market. Ecosystem partners and our customers partner with us for leading technologies, perfect-fit solutions and continuous innovation.

With a proven track record in IoT innovation, we continue to seamlessly and securely connect people and machines. Many IoT trends, such as smart devices and wearables, electromobility and connected cars, smart factories and homes, and energy intelligence are being driven by technologies that develop with XENSIV™ sensors families as one of their key elements. Today, we are already inspiring the next generation of smart environments, capable of understanding and responding to human communication.

Infineon's semiconductors are at the very heart of machine-to-machine (M2M), human-machine interface (HMI), mobile and wireless infrastructure technologies. As the technological boundary between humans and machines gradually disappears, these devices need even more advanced intelligence, enriched with voice assistance capabilities and the latest sensor fusion innovations, not to mention robust security technologies to protect personal data. Infineon's sensors and microphones are already delivering this intelligent functionality and inspiring the next step in mobile connectivity.

www.infineon.com/sensors

XENSIV™ MEMS microphone

Time to debottleneck your audio chain

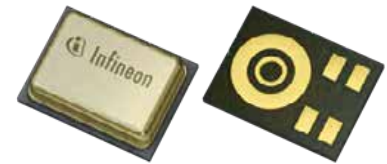

The popularity of voice user interfaces and the usage of audio recording to share information and experiences are increasing dramatically. However, the performance of microphones often limits the potential of today's cutting edge devices. Not anymore!

Infineon's XENSIV™ MEMS microphones introduce a new performance class for digital MEMS microphones that overcome existing audio chain limitations. IM69D130 is designed for applications where low self-noise (high SNR), wide dynamic range, low distortions and a high acoustic overload point are required.



Don't miss a single thing!

With XENSIV™ MEMS microphones, you can create a new user experience benchmark in audio recording.



Talk to tomorrow and be heard!

With XENSIV™ MEMS microphones, you can define the benchmark in speech recognition for a new user experience.



Hear nothing but your favorite beats!

With XENSIV™ MEMS microphones, you can create headsets offering users a benchmark noise cancellation experience.

Features

- > 69 dB(A) signal-to-noise ratio (SNR)
- > Below 1 percent distortions at 128 dB SPL (130 dB SPL AOP)
- > Digital (PDM) interface with 6 μ s group delay at 1 kHz
- > Tight sensitivity (-36 ± 1 dB) and phase (± 2 deg) tolerances
- > 28 Hz low frequency roll-off
- > 4.0 x 3.0 x 1.2 mm package

Benefits

- > High fidelity and far field audio recording
- > Matched, noise and distortion free audio signals for advanced audio processing
- > Ultralow group delay for latency-critical applications
- > No analog components required

Typical applications

- > High quality audio capturing: e.g. cameras, camcorders, conference systems
- > Voice user interface: e.g. smart speaker, home automation and IoT devices
- > Active noise cancellation: headphones and earphones
- > Audio pattern detection: predictive maintenance, security or safety applications

www.infineon.com/microphones

Infineon's dual backplate MEMS technology is based on a miniaturized symmetrical microphone design, similar as utilized in studio condenser microphones, and results in high linearity of the output signal within a dynamic range of 105 dB. The microphone noise floor is at 25 dB[A] (69 dB[A] SNR) and distortion does not exceed 1 percent even at sound pressure levels of 128 dB SPL (AOP 130 dB SPL). The flat frequency response (28 Hz low-frequency roll-off) and tight manufacturing tolerance result in close phase matching of the microphones, which is important for multi-microphone (array) applications.

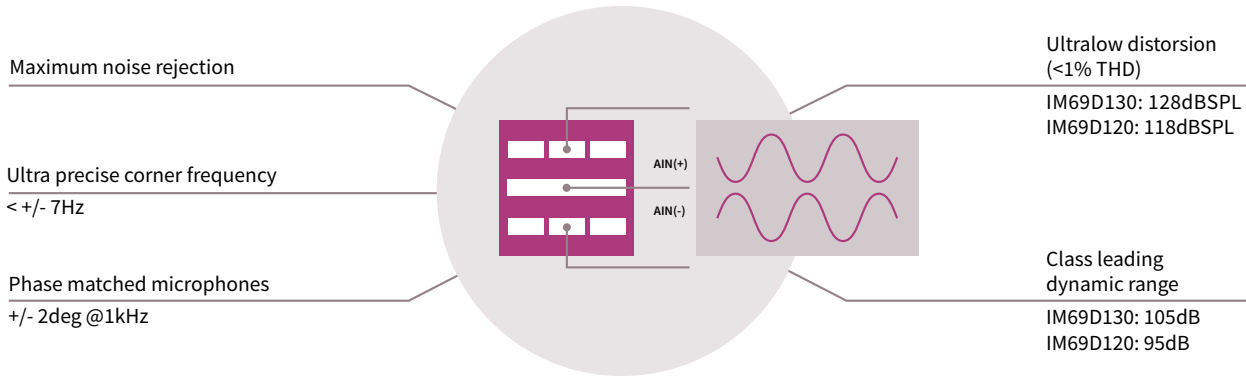

Product portfolio

Product	OPN	Package	Current consumption	Sensitivity	Signal to noise	Supply voltage
IM69D130	IM69D130V01XTSA1	LLGA-5-1	980 μA	-36 dBFS	69 dB	1.62-3.6 V
IM69D120	IM69D120V01XTSA1	LLGA-5-1	980 μA	-26 dBFS	69 dB	1.62-3.6 V

Devices with voice user interface			Audio
<p>TV, laptop and set top box</p> <p>+ Highest beam-forming precision</p>	<p>Digital voice assistance and robots</p> <p>+ Best speech recognition</p>	<p>Smart home appliances</p> <p>+ Extended voice pickup distance</p>	<p>+ Best audio quality</p>
Conference	Security	Headsets	Industry 4.0
<p>+ Ultraclear voice pickup</p>	<p>+ Sensitive to softest audio signals</p>	<p>+ Best noise attenuation</p>	<p>+ Smallest pattern deviation detection</p>

www.infineon.com/microphones

XENSIV™ digital barometric pressure sensor

For mobile and wearable devices

Infinion's digital barometric pressure sensor family is the best choice for mobile and wearable devices due to its small form factor, high precision and low power consumption. Pressure sensing is based on capacitive technology which guarantees ultrahigh precision ($\pm 2/\pm 5$ cm) and relative accuracy (± 0.6 hPa) over a wide temperature range. The sensor's internal signal processor converts the output from the pressure and temperature sensor elements to 24-bit results. Each pressure sensor has been calibrated individually and contains calibration coefficients. The coefficients are used in the application to convert the measurement results to true pressure and temperature values. All sensors have a FIFO that can store the latest 32 measurements. Since the host processor can remain in a sleep mode for a longer period between readouts, a FIFO can reduce the system power consumption. Sensor measurements and calibration coefficients are available via the serial I2C/SPI interface.

DPS310

Barometric pressure sensor with very low power consumption, recommended for applications where power consumption is critical and highest precision in pressure metering is required.

DPS422

Monolithic chip solution that has an ultrasmall critical area and a very thin package (0.73 mm typ.). Beneath high precision pressure metering, DPS422 offers also highly accurate absolute temperature sensing ($\pm 0.4^\circ\text{C}$), which is required in applications like weather stations, thermostats, etc. It can be used in applications such as weather stations / smart thermostats and offers additional features by pressure sensing (e.g. intruder detection, weather forecast).

DPS368*

DPS368 offers the best-in-class resolution (± 2 cm), a very fast read-out speed and a low current consumption. The sensor can be used in harsh environment, as it is robust against water (IPx8 - 50 m under water for 1 hour), dust and humidity. The small package size saves up to 80 percent of the space and makes the DPS368 ideal for mobile applications and wearable devices.

Typical applications

- › Drones: altitude detection and height stability
- › Health and fitness: accurate elevation gain and step counting (e.g. for smart watches)
- › Outdoor navigation: GPS start-up time/accuracy improvement; dead reckoning (e.g. in tunnels)
- › Indoor navigation: floor detection e.g. in shopping malls and parking garages
- › Smart home: micro weather forecasting; room temperature control; intruder detection
- › Air flow control: Smart filter replacement alarm (e.g. in home appliances); predictive maintenance
- › Health care: fall detection; respiratory devices; smart inhalers

Key product features	DPS310	DPS422	DPS368*
Package size	LGA 8-pin: 2.0 x 2.5 x 1.0 mm	LGA 8-pin: 2.0 x 2.5 x 0.73 mm	LGA 8-pin: 2.0 x 2.5 x 1.1 mm
Operating pressure range	300 ... 1200 hPa		
Operating temperature range	-40 ... 85°C		
Pressure level precision	± 0.005 hPa (or ± 0.05 m)		± 0.002 hPa (or ± 0.02 m)
Relative accuracy	± 0.06 hPa (or ± 0.5 m)		
Absolute accuracy	± 1 hPa (or ± 8 m)		
Temperature accuracy	0.5°C	< 0.4°C	0.5°C
Pressure temperature sensitivity	0.5 Pa/K		
Measurement time	3.6 ms (low precision); 27.6 ms (standard mode)		
Average current consumption @ 1 Hz sampling rate	1.7 μA pressure measurement, 1.5 μA temp. measurement, standby 0.5 μA	1.7 μA pressure measurement, 2.0 μA temp. measurement, standby < 1 μA	1.7 μA pressure measurement, 1.5 μA temp. measurement, standby 0.5 μA
Supply voltage	V_{DDIO} : 1.2 - 3.6 V; V_{DD} : 1.7 - 3.6 V		
Operating modes	Command (manual), background (automatic), standby		
Interface	I2C and SPI, both with optional interrupt		

www.infineon.com/pressuresensor

* Environmentally protected pressure sensor, available Q2 2019

Functional block diagram

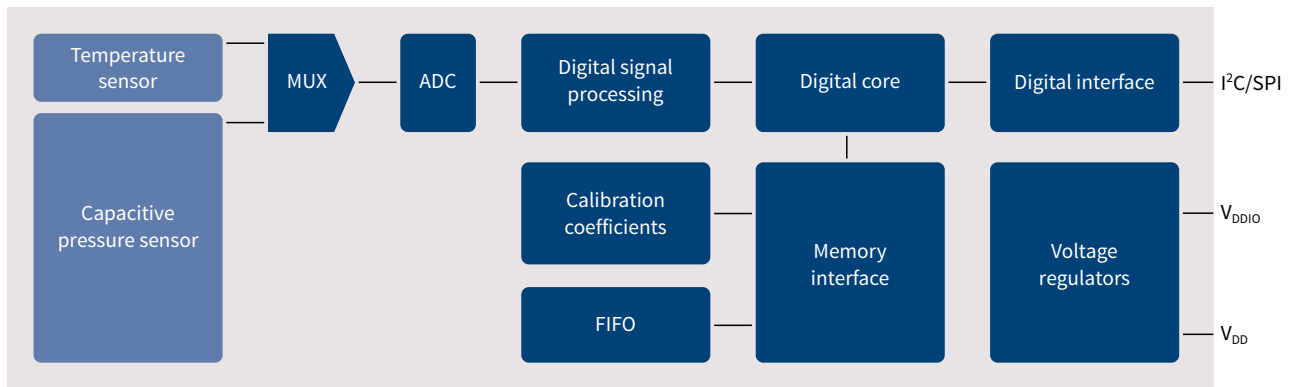

Application circuit example (in I²C configuration)

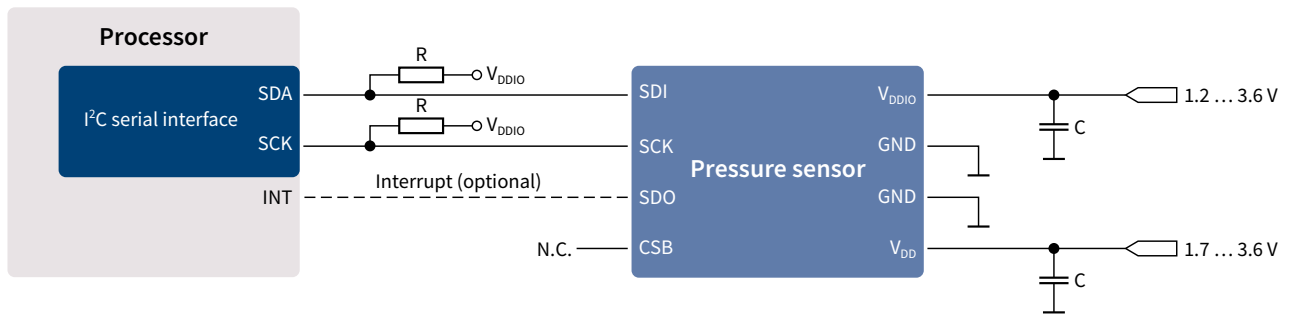

Pin configuration (top view)

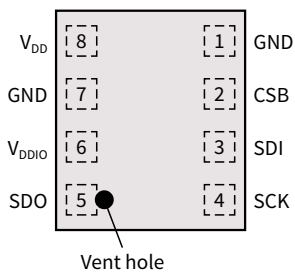

Pin	Name	Function
1	GND	Ground
2	CSB	Chip select
3	SDI	Serial data in/out
4	SCK	Serial clock
5	SDO	Serial data out
6	V _{DDIO}	Digital interface supply
7	GND	Ground
8	V _{DD}	Analog supply

DPS310 package drawing



DPS368 package drawing

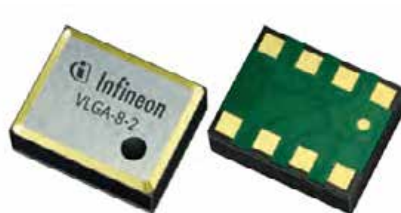

DPS422 package drawing

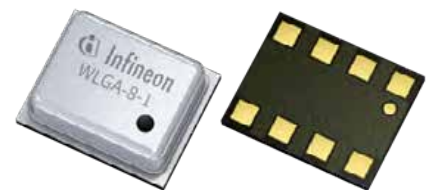

Absolute pressure sensors (MAP and BAP)

Infiniteon's pressure sensors are ideal for a wide range of applications in the automotive and industrial sectors. Typical applications in automotive include side airbag, engine control and seat comfort with high quality, highly accurate products adhering to ISO26262 standard. Infineon offers the ideal portfolio for these systems.

The analog and digital interfaces of Infineon's pressure sensors provide customers with a high degree of design flexibility and enable manufacturers to meet evolving market demands.

KP21x/KP22x

Analog manifold air pressure sensor IC family (MAP + turbo MAP)

Features

- › Manifold air pressure measurement – MAP and turbo MAP
- › Excellent accuracy of up to 1.0 kPa over a large temperature range
- › Ratiometric analog voltage output proportional to the applied pressure
- › Output signal fully compensated over pressure and temperature
- › Pressure range from 10 to 400 kPa
- › Temperature range from -40 to +140°C
- › Output clamping (optional)
- › Complete product family available with multiple transfer function
- › Reverse polarity protection
- › Green SMD package

KP23x

Analog barometric air pressure (BAP) sensor IC family

Features

- › Absolute air pressure measurement
- › Excellent accuracy of 1.0 kPa over a large temperature range
- › Ratiometric analog voltage output proportional to the applied pressure
- › Output signal fully compensated across pressure and temperature range
- › Pressure range from 40 to 115 kPa
- › Temperature range from -40 to +125°C
- › Serial service interface
- › Open bond detection (OBD) for supply and GND
- › Inverse polarity protection
- › Green SMD package

KP275

Media robust MAP sensor with digital interface

Features

- > Media robustness for current automotive requirements
- > Digital single edge nibble transmission (SENT) interface
- > Excellent accuracy of ± 0.77 percent FFS
- > Green SMD package
- > Temperature range -40 to +170°C
- > Integrated NTC temperature sensor functionality

Block diagram

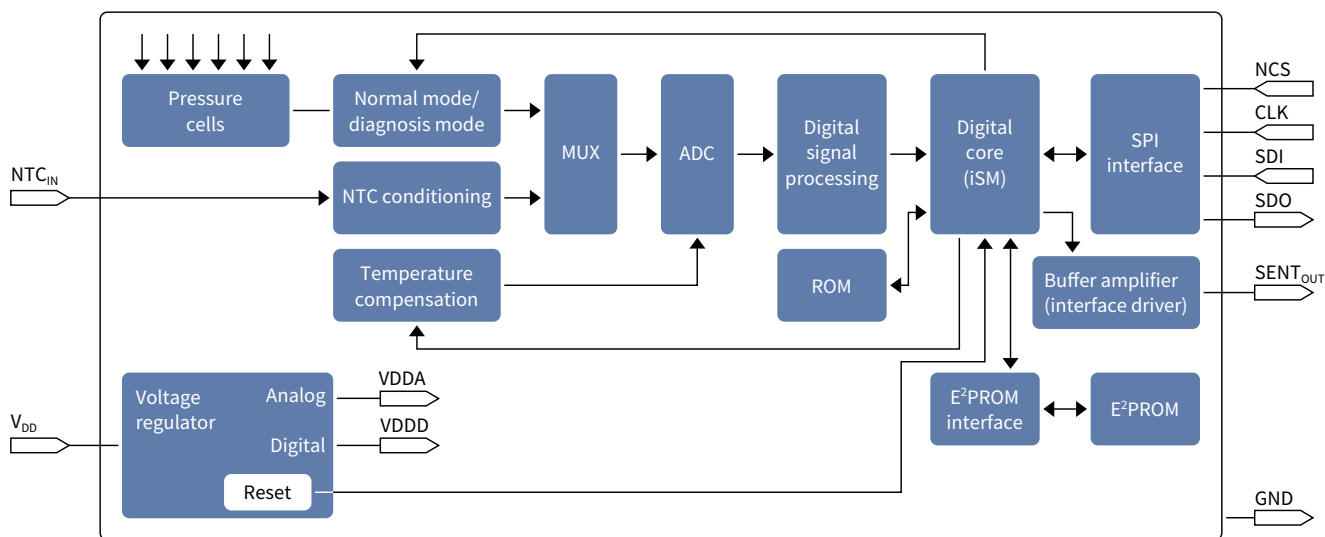

Integrated pressure sensor ICs for manifold and barometric air pressure

Product	Pressure range [kPa]	Max. accuracy [kPa]	Max. operating temperature [°C]	Automotive	Industrial
KP21x	10 ... 150	1.0	140	✓	✓
KP22x	10 ... 400	2.5	140	✓	✓
KP23x	15 ... 115	1.0	125	✓	✓
KP236N6165	60 ... 165	1.0	125	✓	✓
KP253	60 ... 165	1.0	125	✓	✓
KP254	40 ... 115	1.5	125	✓	✓
KP255	10 ... 125	1.4	140	✓	✓
KP256	60 ... 165	1.0	125	✓	✓
KP275	10 ... 400	3.0	170	✓	✓

XENSIV™ 24 GHz radar sensor ICs

Infinion offers a wide portfolio of mmWave radar sensors to address different customer requirements. The BGT24M/L family is the largest and highest integrated 24 GHz radar transceiver family currently on the market, saving ~30 percent board space compared to discrete lineups. Infineon provides a total of four 24 GHz industrial radar chips, providing a range of different transmitter and receiver channel configurations, supporting different application requirements.

Applications

- › Building and smart home (IoT)
- › Indoor/outdoor lighting
- › Security
- › UAV/multicopters
- › Robotics
- › Smart street lighting



Key benefits

- › Direction, proximity and speed detection
- › Hidden mounting capability
- › Maintains operation through harsh weather conditions
- › Motion tracking
- › Sensitive enough to capture breathing and heartbeat
- › Target positioning
- › Adaptable to different application requirements

In addition to the BGT24M/L family of MMIC chips, Infineon provides a continuously expanding range of evaluation and demonstration boards to support the testing and development of radar in multiple applications. All boards are provided with base level software to support the ease of use and faster time-to-market integration.

Utilizing our strong network of partners, the radar portfolio is extended to include a range of easy-to-integrate modules. Each of them contains Infineon's 24 GHz MMIC.

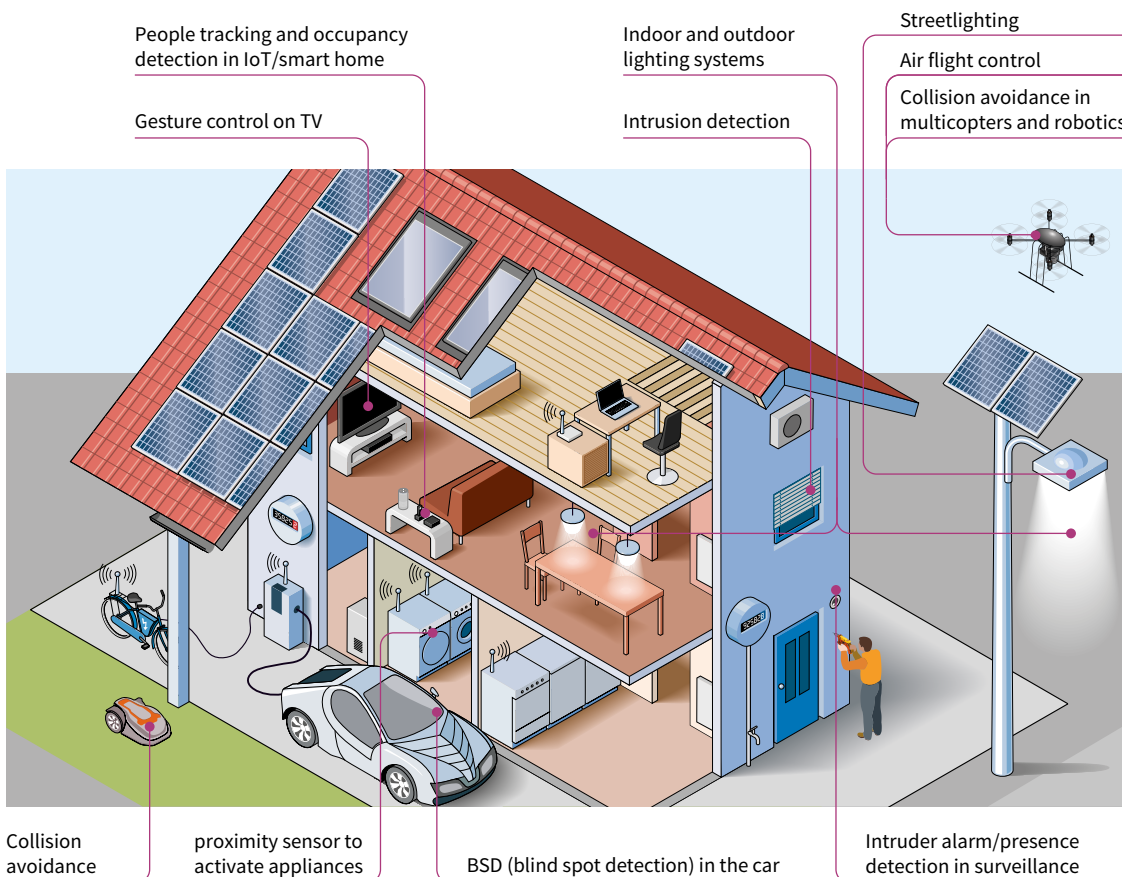

Infineon BGT24M/L family of MMIC chips

Infineon's range of 24 GHz industrial radar chips provides four configurations of transmit and receiver channels, ensuring that there is a chip to support your specific application. From basic applications such as motion detection in security systems, which only requires one transmit and one receive channel, to more complex applications like 3D positioning, which requires two or more receive channels, our range of radar chips supports all of your requirements.

Features	Infineon MMIC	Benefits
----------	---------------	----------

- > 24 GHz ISM band operation for motion, speed, direction movement and distance measurements
- > 4 MMIC chips available
- > Highly integrated

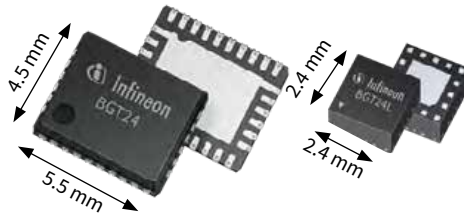

- > Long range distance detection of moving objects up to 30 m
- > Wide range speed detection up to ±100 km/h
- > Lower BOM costs

Product	Configuration	Features
BGT24MTR11	1Tx + 1Rx	<ul style="list-style-type: none"> > Measures not just motion, but also speed, direction, and distance > Small form factor
BGT24MR2	2Rx	<ul style="list-style-type: none"> > Resistance to moisture, dirt and temperature > Increased area coverage
BGT24MTR12	1Tx + 2Rx	<ul style="list-style-type: none"> > Discrete design > Energy savings > Privacy protection
BGT24LTR11	1Tx + 1Rx	<ul style="list-style-type: none"> > Adaptable to different application requirements > Highly integrated chips eliminating costly external components

The BGT24LTR11N16 key features

- > 24 GHz transceiver MMIC
- > Fully integrated low phase noise V_{CO}
- > Built in temperature compensation circuit for V_{CO} stabilization, no PLL needed
- > Low power consumption
- > Fully ESD protected device
- > Single ended RF and IF terminals
- > 200 GHz bipolar SiGe:C technology B7HF200
- > Single supply voltage 3.3 V
- > Divider output for PLL operation
- > Smallest 24 GHz transceiver in the market

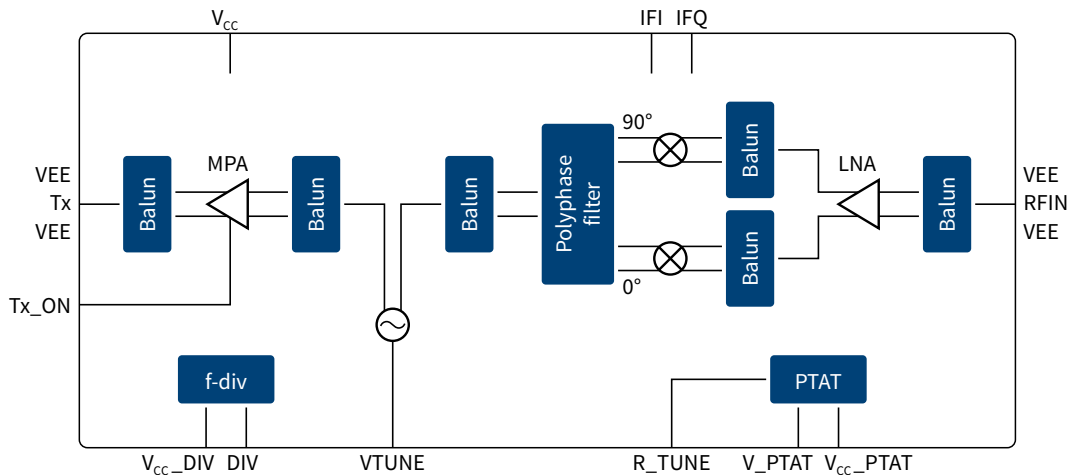

www.infineon.com/24GHz

24 GHz evaluation and demonstration boards

Infiniteon's range of 24 GHz evaluation and demo boards continues to expand to support the needs of our customers and the increasing number of innovative ways radar is being incorporated into new applications.

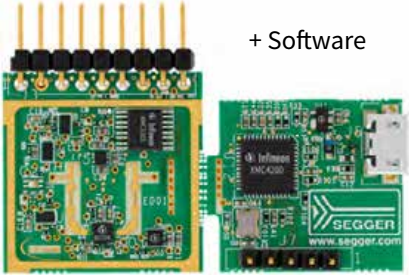
Features	Infineon development kit	Benefits
<ul style="list-style-type: none"> › Three system boards available › All include 24 GHz radar and XMC™ microcontroller › Kit contains user manual, GUI, MATLAB compiler and Gerber files › Requires software 	<div style="text-align: center;">  <p>+ Software</p> <p>Demokit with SW, reference design</p> </div>	<ul style="list-style-type: none"> › Capability to detect motion, speed and direction of movement (approaching or retreating) distance and angle of arrival based on hardware › Firmware/software available for each radar mode

Sense2GOL (BGT24LTR11 + XMC1300)	Distance2Go (BGT24MTR11 + XMC4200)	Position2Go (BGT24MTR12 + XMC4700)
<ul style="list-style-type: none"> › Capability to detect motion, speed and direction of movement (approaching or retreating) › Precise measurement of object detection compared to PIR › Operates in harsh environments and detects through non-metallic materials › Low power mode for enhanced battery life › One of the world's smallest complete radar + MCU development kit › BGT24LTR11 – 24 GHz highly integrated RF MMIC › XMC1300 ARM® Cortex®-M0 –32-bit industrial microcontroller › Debug over Cortex 10 pin debug connector › Integrated multiple element patch antennas 	<ul style="list-style-type: none"> › Capability to detect distance of multiple targets › Capability to detect motion, speed and direction of movement (approaching or retreating) › Operates in harsh environments and detects through non-metallic materials › BGT24MTR11 – 24 GHz highly integrated RF MMIC › XMC4200 ARM® Cortex®-M4 –32-bit industrial microcontroller › Debug over Cortex 10 pin debug connector › Integrated multiple element patch antennas 	<ul style="list-style-type: none"> › Capability to detect and track position of multiple targets › Capability to detect distance of multiple targets › Capability to detect motion, speed and direction of movement (approaching or retreating) › Operates in harsh environments and detects through non-metallic materials › BGT24MTR12 – 24 GHz highly integrated RF MMIC › XMC4700 ARM® Cortex®-M4 –32-bit industrial microcontroller › Debug over Cortex 10 pin debug connector › Integrated multiple element patch antennas
<p>Main applications</p> <ul style="list-style-type: none"> › Security › Lighting control › Automatic door opener › Vital sensing 	<p>Main applications</p> <ul style="list-style-type: none"> › Drone: soft landing/obstacle avoidance › Smart toilets › Tank level sensing › Intelligent switches 	<p>Main applications</p> <ul style="list-style-type: none"> › Drone/robots: obstacle avoidance › Security › People tracking (IoT, smart home) › Vital sensing
<p>Board dimensions</p> <ul style="list-style-type: none"> › 25 mm x 25 mm (pictured with the Segger debugger break-off board for reprogramming) 	<p>Board dimensions</p> <ul style="list-style-type: none"> › Board 36 mm x 45 mm 	<p>Board dimensions</p> <ul style="list-style-type: none"> › Board 50 mm x 45 mm
<p>Kit contents</p> <ul style="list-style-type: none"> › User manual › Demonstration board › SW GUI to operate kit › Schematic and bill-of-materials of module 	<p>Kit contents</p> <ul style="list-style-type: none"> › User's manual › Demonstration board › Corner reflector › SW GUI to operate kit › FMCW FW and SW¹⁾ › Doppler FW and SW¹⁾ › Schematic and bill-of-materials of module 	<p>Kit contents</p> <ul style="list-style-type: none"> › User's manual › Demonstration board › Corner reflector › SW GUI to operate kit › FMCW FW and SW › Doppler FW and SW › Schematic and bill-of-materials of module

www.infineon.com/24GHz

1) Usage of the FMCW and/or Doppler FW and SW requires agreeing to Infineon's user's agreement and licensing terms.

24 GHz modules

Partnering with the leading radar solution providers enables Infineon to connect our customers looking for turnkey solutions and design support for a complete range of applications.

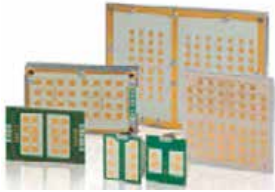
Features	Partner modules using Infineon chips	Benefits
<ul style="list-style-type: none"> Complete module, including radar MMIC, antenna options, MCU signal processing options, and SW options (Doppler, FSK and FMCW versions available) 	 <p>Module (RF module; RF module + MCU including SW)</p>	<ul style="list-style-type: none"> Ease of design Turnkey solution, no need for test and certification

By integrating Infineon's 24GHz MMIC chip into the partners easy-to-use and simple-to-integrate modules the complexity and time to market for a range of applications such as home automation, multicopter, robotics and street lighting, are reduced.

Lighting

Security

Touch free switches

Door automation



New application or simple PIR replacement? Radar has it covered.

Radar, used in motion detection applications, increases accuracy when compared to passive infrared (PIR) technology, allowing a more precise measurement of object detection, and providing new capabilities such as the detection of speed and the direction of moving objects. Radar is also superior to camera-based systems by allowing detection of the objects while keeping identities anonymous.

Visit the link below to view our network of partners who provide modules and design support for all 24GHz industrial applications: www.infineon.com/24GHzpartners

www.infineon.com/24GHz

High-precision current sensor for industrial applications - based on Hall technology

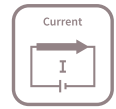

TLI4970: the miniaturization advantage

TLI4970 is a high-precision current sensor for industrial applications, based on our proven Hall technology. The coreless concept significantly reduces footprint compared with existing solutions. Infineon's current sensor is an easy-to-use, fully-digital solution, which does not require external calibration or additional parts such as A/D converters, 0 pAmps or reference voltage. It thus significantly reduces overall implementation effort, as well as PCB space and cost. The differential measurement principle integrated in the TLI4970 sensor suppresses interference caused by external magnetic fields. Accordingly, the sensor achieves an extremely low offset of just 25 mA. With conventional current measurement principles, the measuring accuracy is always governed by the ambient conditions (e.g. the temperature).

TLI4970 is more accurate than existing open-loop and comparable to closed-loop systems. It also provides additional functions such as fast overcurrent detection and programmable filter, yet it has a significantly smaller footprint and lower power consumption.

Infineon's sensor is extremely robust against external magnetic fields thanks to implemented stray field suppression, and is also suitable for fast overcurrent detection at a pre-configurable level. This allows the control unit to switch off independently of the main measurement path and protect power consumers from damage.

Features

- > Fully calibrated digital output
- > High accuracy over life time due to on-chip temperature and stress compensation
- > Programmable low-pass filter for measuring current (0 to 18 kHz)
- > Fast, configurable overcurrent detector (< 1.8 μ s typ.)
- > Inherent magnetic stray field suppression
- > Small package size and weight for SMD mounting

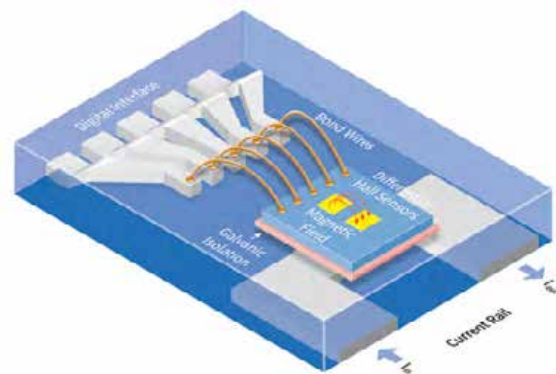

Applications (AC and DC current measurement)

- > Photovoltaic and general purpose inverters
- > Power supplies (SMPS)
- > Battery chargers
- > Lighting applications
- > Electrical drives

Product	Accuracy ¹⁾	Current range [A]	Bandwidth [kHz]	Resolution [mA/LSB]	Automotive	Industrial	Package
TLI4970-D050T4	±1.6	±50	18	12.5	-	✓	TISON-8
TLI4970-D050T5	±3.5	±50	18	12.5	-	✓	TISON-8
TLI4970-D025T4	±1.6	±25	18	6.25	-	✓	TISON-8
TLI4970-D025T5	±3.5	±25	18	6.25	-	✓	TISON-8

www.infineon.com/current-sensor

1) Total error over lifetime and temperature

Hall switches

The energy-saving option with excellent accuracy and robustness

TLE/TLI/TLV4961/64/6: Energy-efficient Hall switch family for up to 32 V

The TLE/TLI/TLV496x-xM/L family of Hall switches saves energy and enables designers to create precise, compact systems. With an operational current consumption of just 1.6 mA, TLE/TLI/TLV496x-xM/L products can cut energy consumption by up to 50 percent compared with similar competitor products. Thanks to its small magnetic hysteresis, the family paves the way for precise switching points in systems. The integrated temperature profile compensates magnetic drifts and enables stable performance over temperature and lifetime.

TLE/TLI/TLV496x-xM products come in the smallest SOT23 package, thus reducing height by 10 percent compared with predecessor products. The sensors also feature an integrated functionality test for better system control.

Features

- › Current consumption of just 1.6 mA
- › 3 to 32 V supply voltage range (over voltage up to 42 V)
- › 7 kV ESD protection (HBM)
- › Overtemperature and overcurrent protection
- › Temperature compensation
- › Smallest SOT23 package
- › Dedicated products for industrial applications (TLI496x)
- › AEC-Q100 qualified
- › Electrical drives

Applications

- › Window lifter (index counting)
- › Power closing (index counting)
- › Gear stick (position detection)
- › Seat belt (position detection)
- › BLDC commutation
(e.g. wiper seat belt pretensioner, pump, seating)
- › Service robots
- › Power tools
- › White goods

Product	Type	Operating point BOP	Release point BRP	Hysteresis Δ BHY	Automotive	Industrial	Consumer	Package
TLE4961-1M/L	Latch	2.0	-2.0	4.0	✓	✓	✓	SOT23/SSO-3-2
TLE4961-2M	Latch	5.0	-5.0	10.0	✓	✓	✓	SOT23
TLE4961-3M/L	Latch	7.5	-7.5	15.0	✓	✓	✓	SOT23/SSO-3-2
TLE4964-1M	Switch	18.0	12.5	5.5	✓	✓	✓	SOT23
TLE4964-2M	Switch	28.0	22.5	5.5	✓	✓	✓	SOT23
TLE4964-3M	Switch	12.5	9.5	3.0	✓	✓	✓	SOT23
TLE4964-5M	Switch	7.5	5.0	2.5	✓	✓	✓	SOT23
TLE4968-1M/L	Bipolar	1.0	-1.0	2.0	✓	✓	✓	SOT23/SSO-3-2
TLE4961-5M	Latch	15.0	-15.0	30.0	✓	✓	✓	SOT23
TLE4961-4M	Latch	10.0	-10.0	20.0	✓	✓	✓	SOT23
TLE4964-4M	Switch	10.0	8.5	1.5	✓	✓	✓	SOT23
TLE4964-6M	Switch	3.5	2.5	1.0	✓	✓	✓	SOT23
TLV4964-1M	Switch	18.0	12.5	5.5	-	-	✓	SOT23
TLV4964-2M	Switch	28.0	22.5	5.5	-	-	✓	SOT23
TLI4961-1M/L	Latch	2.0	-2.0	4.0	-	✓	✓	SOT23/SSO-3-2
TLV4961-3M	Latch	7.5	-7.0	15.0	-	-	✓	SOT23

TLE/TLI4963/65-xM

5 V high-precision automotive/industrial Hall-effect sensors

By offering an excellent magnetic behavior Infineon's switches are ideally suited for:

- > Index counting application with a pole wheel
- > Rotor position detection (BLDC motors)
- > Open/close detection

Features

- > 3.0 to 5.5 V operating supply voltage
- > Low current consumption 1.4 mA
- > ESD protection 4 kV HBM
- > Active error compensation (chopped)
- > High stability of magnetic thresholds
- > Low jitter (typ. 0.35 μs)
- > Operating temperature range:
 - from -40 to +170°C (TLE496x-xM)
 - from -40 to +125°C (TLI496x-xM)
- > Small SMD package SOT23
- > TLE: AEC-Q100 qualified
- > TLI: JESD47 qualified



Product	Type	Operating point B _{OP}	Release point B _{RP}	Hysteresis ΔB _{HY}	Automotive	Industrial	Package
TLE4963-1M	Latch	2.0	-2.0	4.0	✓	–	SOT23
TLE4963-2M	Latch	5.0	-5.0	10.0	✓	–	SOT23
TLE4965-5M	Unipolar switch	7.5	5.0	2.5	✓	–	SOT23
TLI4963-1M	Latch	2.0	-2.0	4.0	–	✓	SOT23
TLI4963-2M	Latch	5.0	-5.0	10.0	–	✓	SOT23
TLI4965-5M	Unipolar switch	7.5	5.0	2.5	–	✓	SOT23

TLV496x-xTA/B

Precision Hall-effect sensor for consumer applications in leaded package

Features

- > 3.0 to 26 V operating supply voltage
- > Low current consumption 1.6 mA
- > ESD protection 4 kV HBM
- > Operating temperature range from -40 to +125 °C
- > Leaded package TO92S

Applications

- > BLDC motor commutation for consumer devices (e.g. e-bikes, fans, aircons)
- > Position detection e.g. flaps and control buttons



Product	Type	Operating point B _{OP}	Release point B _{RP}	Hysteresis ΔB _{HY}	Consumer	Industrial	Package
TLV4961-1TA	Latch	2.0	-2.0	4.0	✓	TO92S-3-1	TO92S-3-1
TLV4961-1TB	Latch	2.0	-2.0	4.0	✓	TO92S-3-2	TO92S-3-2
TLV4961-3TA	Latch	7.5	-7.5	15.0	✓	TO92S-3-1	TO92S-3-1
TLV4961-3TB	Latch	7.5	-7.5	15.0	✓	TO92S-3-2	TO92S-3-2
TLV4964-4TA	Unipolar switch	10.0	8.5	1.5	✓	TO92S-3-1	TO92S-3-1
TLV4964-4TB	Unipolar switch	10.0	8.5	1.5	✓	TO92S-3-2	TO92S-3-2
TLV4964-5TA	Unipolar switch	7.5	5.0	2.5	✓	TO92S-3-1	TO92S-3-1
TLV4964-5TB	Unipolar switch	7.5	5.0	2.5	✓	TO92S-3-2	TO92S-3-2
TLV4968-1TA	Latch	1.0	-1.0	2.0	✓	TO92S-3-1	TO92S-3-1
TLV4968-1TB	Latch	1.0	-1.0	2.0	✓	TO92S-3-2	TO92S-3-2

www.infineon.com/Hall-switches

TLE4966

Two-in-one double Hall sensor

Features

- › Two Hall probes
- › Excellent matching between the two Hall probes
- › Hall plate distance of 1.45 mm
- › Industry standard
- › Outstanding quality
- › Information on direction and speed
- › TSOP6 package
- › AEC-Q100 qualified

Applications

- › Window lifter
- › Sunroof
- › Automatic tailgate
- › Automated doors
- › Sun blinds

Product	Type	Operating point B_{OP}	Release point B_{RP}	Hysteresis ΔB_{HY}	Automotive	Package
TLE4966K/L	Double Hall, speed and direction output	7.5	-7.5	15	✓	TSOP6/SSO-4-1
TLE4966-2K	Double Hall, two independent outputs	7.5	-7.5	15	✓	TSOP6
TLE4966-3K	Double Hall, speed and direction output	2.5	-2.5	5	✓	TSOP6
TLE4966V-1K	Vertical double Hall, speed and direction output	2.5	-2.5	5	✓	TSOP6

Linear Halls



TLE499x family: programmable analog/digital linear Hall sensor family

Infiniteon's family of TLE499x linear Hall ICs is tailored to the needs of highly accurate angular and linear position detection and current measurement applications. Each product measures the vertical component of a magnetic field and outputs a signal that is directly proportional to the magnetic field. These programmable linear Hall sensors come with different interface options: TLE4997 features ratiometric analog output, while TLE4998P comes with pulse width modulation (PWM), TLE4998S with single edge nibble transmission (SENT) and TLE4998C with short PWM codes (SPC). These high-precision 12-bit resolution linear Hall sensors feature EEPROM memory for flexible programming across a wide range of parameters.

Thanks to digital signal processing based on a 20-bit DSP architecture plus digital temperature compensation, these sensors deliver outstanding temperature stability compared with similar compensation methods. TLE4998 also includes stress compensation to withstand stress effects from the package, such as moisture, thus ensuring best-in-class accuracy over the device's lifetime.

Features

- › Best-in-class accuracy with low drift of output signal temperature range lifetime (including stress compensation in TLE4998)
- › Programmable transfer function (gain, offset), clamping, bandwidth and temperature characteristics
- › AEC-Q100 qualified
- › Available in various packages including SSO-3-9 with two integrated capacitors to improve ESD and ESC behavior
- › Dual-die SMD package
- › ISO26262 ready

Applications

- › Detecting linear and angular position
- › Detecting pedal and throttle position
- › Steering torque measurement
- › Headlight leveling
- › High-current sensing
- › Seat position and occupant detection
- › Suspension control
- › Detecting gear stick/lever positions
- › Detecting liquid levels in fuel tanks
- › Current sensing e.g. for battery management

Product	Programmable	Number of pins	Sensitivity	Magnetic offset	Supply voltage (extended range)	Automotive	Interface	Package
TLE4997	EEPROM	3/ Single die SMD 8	±12.5 to ±300	< ±400 μT	5 V ±10% (7 V)	✓	Analog	SSO-3-10 TDSO-8
TLE4998P	EEPROM	3/4/ Single die SMD 8	±0.2 to ±6%/mT	< ±400 μT	5 V ±10% (16 V)	✓	PWM	SSO-3-10 SSO-4-1 SSO-3-9 (2 capacitors) TDSO-8
TLE4998S	EEPROM	3/4/ Single die SMD 8	±8.2 to ±245 LSB/mT	< ±400 μT	5 V ±10% (16 V)	✓	SENT	SSO-3-10 SSO-4-1 SSO-3-9 (2 capacitors) TDSO-8
TLE4998C	EEPROM	3/4/ Single die SMD 8	±8.2 to ±245 LSB/mT	< ±400 μT	5 V ±10% (16 V)	✓	SPC	SSO-3-10 SSO-4-1 SSO-3-9 (2 capacitors) TDSO-8

Dual linear Halls

Two sensors in one SMD package



The SMD package (TDSO) includes two independent sensors with separate power supply and separate signal outputs. Due to special mounting technology, Infineon is able to keep dual-sensor package size very small to enable compact PCB layouts and small magnet sizes.

Infineon offers a wide range of Hall sensors in the TDSO package. The combination of two sensors in one package offers sensors redundancy, a feature which is especially interesting for new generation EPS steering systems with increased ISO26262 requirements and other safety critical applications. All sensors are automotive qualified.

Features

- › Two sensors in one package
- › Separate power supply and signal output
- › AEC-Q100 qualified
- › Temperature range from -40 to +125°C
- › Outstanding quality
- › Single-sensor versions available
- › 16-pin and 8-pin versions available
- › ISO26262 ready

Automotive applications

- › Steering torque systems
- › Pedal position
- › Any other safety critical application

Product	Interface	Dual-/single-sensor available	Package
TLE4997A8D	Analog	Yes/yes	TDSO-8
TLE4998P8D	PWM	Yes/yes	TDSO-8
TLE4998S8D	SENT	Yes/yes	TDSO-8
TLE4998C8D	SPC	Yes/yes	TDSO-8



Angle sensors

Compact designs in small outline packages

Highest variety - low end to high end, standardized and specialized in all four magnetic technologies: Hall, GMR, AMR and TMR

Infineon's new magnetic sensor products TLE5501, are fast analogue TMR-based angle sensors dedicated to automotive applications. Their fields of use range from steering angle applications, with the highest functional safety requirements, to motors for wipers, pumps and actuators and electric motors in general. They are also ready to be used in industrial and consumer applications like robotics or gimbal. Angle sensors detect the orientation of an applied magnetic field by measuring sine and cosine angle components with monolithically integrated magneto resistive elements.

Infineon's iGMR sensors are ideal for applications with a wide angle range, such as BLDC motors or steering sensors. They are pre-calibrated and ready-to-use. Different levels of signal processing integration enable designers to optimize system partitioning. The XENSIV™ iAMR sensors also perfectly fit applications with the highest accuracy requirements, as they offer best performance over temperature, lifetime and magnetic field range.

iGMR, iAMR and iTMR based angle sensors

Diverse redundant sensor with analog and digital interface

Product	Technology	Die configuration	ISO26262	Sin/cos output	Angle output	Second interface	Accuracy	Package
TLE5009	GMR	Single die	Ready	Analog sin/cos	-	-	0.9°	DSO-8
TLE5009A16(D)	GMR	Dual die	Ready	Analog sin/cos	-	-	1.0°	TDSO-16
TLE5011	GMR	Single die	Ready	SSC (SPI)	-	-	1.6°	DSO-8
TLI5012B	GMR	Single die	Ready	SSC (SPI)	SSC (SPI)	PWM/IIF/SPC/HSM	1.9°	DSO-8
TLE5012B(D)	GMR	Single and dual die	Ready	SSC (SPI)	SSC (SPI)	PWM/IIF/SPC/HSM	1.0°	DSO-8/ TDSO-16
TLE5014C16(D)	GMR	Single and dual die	Compliant	-	SPC	-	1.0°	TDSO-16
TLE5014P16(D)	GMR	Single and dual die	Compliant	-	PWM	-	1.0°	TDSO-16
TLE5014S16(D)	GMR	Single and dual die	Compliant	-	SENT	-	1.0°	TDSO-16
TLE5014SP16(D)	GMR	Single and dual die	Compliant	-	SPI	-	1.0°	TDSO-16
TLE5109A16(D)	AMR	Single and dual die	Ready	Analog sin/cos	-	-	0.5°	TDSO-16
TLE5309D	AMR + GMR	Dual die	Ready	Analog sin/cos	SSC (SPI)	-	AMR 0.5°, GMR 1.0°	TDSO-16
TLE5501	TMR	Single die	Compliant	Analog sin/cos	-	-	1.0°	DSO-8

www.infineon.com/angle-sensors

SPI = Serial peripheral interface

IIF = Incremental interface

PWM = Pulse width modulation

iTMR based angle sensors

Tunneling Magneto Resistive (iTMR) technology is offering high sensing sensitivity with a high output voltage, reducing the need for an internal amplifier. Thus, the sensor can be connected directly to the microcontroller without any further amplification. In addition, iTMR technology shows a very low temperature drift, reducing external calibration and compensation efforts. The iTMR technology is also well known for its low current consumption.

TLE5501

With the TLE5501 products, Infineon is currently launching the first angle sensor products based on iTMR technology. TLE5501 is available in two versions.

TLE5501 - product versions with different pin out:

- › TLE5501 E0001: pin-compatible to TLE5009
automotive qualified acc. AEC-Q100
- › TLE5001 E0002: decoupled bridges for redundant external angle calculation and highest diagnostic coverage, realizing ISO26262-compliant development ASIL D

**Features**

- › Large output signals of up to 0.37 V/V for direct microcontroller connection
- › Discrete bridge with differential sine and cosine output
- › Very low supply current: ~2 mA
- › Magnetic field range (20-100 mT)
- › Typ. angle error ~ 1.0 ° (overtemperature and lifetime)
- › DSO-8 package
- › AEC-Q100, grade 0: TA = -40°C to 150°C (ambient temperature)
- › For TLE5501 E0002:
 - Reaching ASIL D with just one single sensor chip
 - ISO26262-compliant development ASIL D

Applications

- › Steering angle sensor
- › BLDC motor commutation (e.g. wipers, pumps and actuators)
- › Angular position sensing for e.g. robotics or gimbal
- › Electric motors
- › Industrial automation
- › Safety applications

TLE5014(D)



Digital iGMR sensor with an easy-to-use plug-and-play concept for highest functional safety applications

All XENSIV™ TLE5014 angle sensors are available as single and dual die products. The products come pre-configured and pre-calibrated as plug-and-play sensors and are easy to use. Customers can choose between the interfaces SENT, PWM, SPC and SPI. On top of those protocol options, the sensors can be adapted to any kind of application setup via their programmable E²PROM interfaces. TLE5014 magnetic angle sensors meet ISO26262 ASIL C for the single die and ISO26262 ASIL D for the dual die versions. All products are ready for applications with the highest functional safety requirements. The sensors show an extremely small angle error of less than 1° across the entire temperature profile and lifetime. This is particularly helpful in applications with the need for very accurate position sensing such as steering angle sensing or motor commutation. Further application areas range from rotor position measurement, electric power steering (EPS), pedal position to any other kind of position measurement.

Features

- › Easy-to-use, plug-and-play sensors, pre-configured and pre-calibrated
- › Offering high flexibility:
 - Available as single and dual die products
 - 12bit digital interface with protocol options PWM, SENT, SPC and SPI
 - E2 PROM and look-up table for customer configuration and calibration
- › High angle accuracy: max. 1.0° over temperature and lifetime
- › High voltage capability up to 26 V
- › Development fully compliant with ISO26262
 - Developed acc. ASIL D level
 - Dual die sensors reaching ASIL D, single die sensors ASIL-C metrics
- › Safety manual and safety analysis summary report available on request

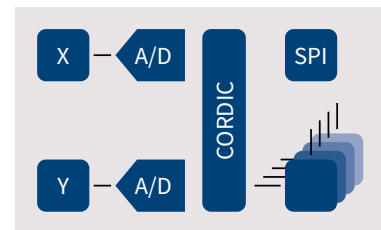

Applications

- › Steering angle sensing (SAS)
- › Motor commutation
- › Rotor position measurement
- › Pedal position
- › Safety applications
- › Any other kind of high-accuracy position measurement

TLE5109A16(D)



Analog iAMR sensor with temperature compensation

Features

- › Features a differential or single-ended analog interface for sine and cosine values
- › Internal temperature drift compensation for gain and offset
- › Also available as a dual-sensor package
- › ISO26262 ready
- › Typical 0.1° angle error over lifetime and temperature range after compensation (max 0.5°)
- › Available as single and dual die product

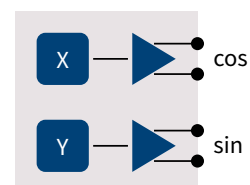

3D magnetic sensors

TLV493D-A1B6/TLI493D-A2B6 for consumer and industrial market

The TLV493D-A1B6 sensor realizes an accurate three-dimensional sensing with extremely low power consumption in a small 6-pin package. Capable of detecting the magnetic field in the x, y, and z-direction, the sensor is ideally suited for the measurement of linear, rotation or 3 dimensional movements. Thanks to its small package and low power consumption, the TLx493D-AxB6 can be used in new applications, replacing potentiometer and optical solutions. Featuring contactless position sensing and high temperature stability of the magnetic threshold, the sensor allows systems getting smaller, more accurate and more robust.

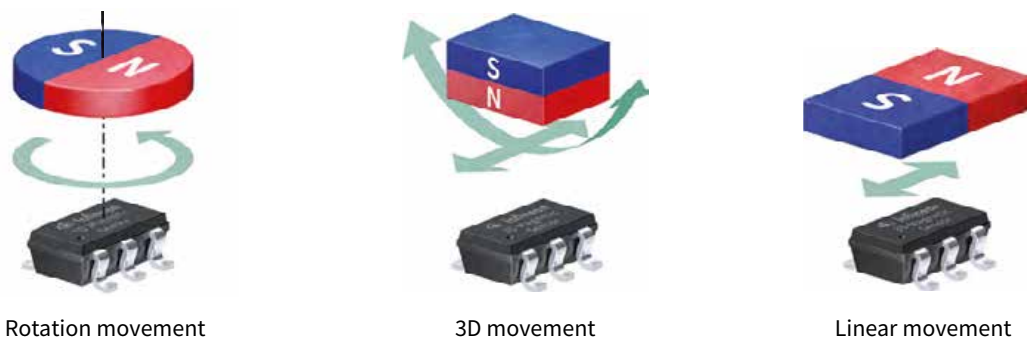

Features

- › 3D magnetic sensing
- › Integrated temperature sensing
- › Low current consumption
 - 7 nA in power-down mode
 - 10 μ A in ultralow power mode
- › 2.8 to 3.5 V operating supply voltage
- › Digital output via a 2-wire standard I2C interface
- › Bx, By and Bz linear field measurement up to ± 160 mT
- › JESD47 qualified
- › 12-bit data resolution for each measurement direction
- › Various resolution options from 65 μ T/LSB to 130 μ T
- › Operating temperature range from -40 to $+125^\circ\text{C}$

Product	Temperature range	Qualification	Linear magnetic range	Resolution	IDD	Update rate	Package	Ordering code
TLV493D-A1B6	$-40 \dots 125^\circ\text{C}$	JESD47	± 130 mT (typ)	98 μ T/LSB	7 nA – 3.7 mA	10 Hz – 3.3 kHz	TSOP6	SP001286056
TLI493D-A2B6	$-40 \dots 105^\circ\text{C}$	JESD47	± 160 mT (min) ± 100 mT (min)	130 μ T/LSB (65 μ T/LSB) ¹⁾	7 nA – 3.3 mA	10 Hz – 8.4 kHz	TSOP6	SP001689844

1) Half range mode

While the TLV493D-A1B6 just supports a typical value for the linear magnetic range of ± 130 mT, the TLI493D-A2B6 specification includes also a minimum value of ± 160 mT.

With the TLI493D-A2B6,s a broader microcontroller compatibility as well an enhanced feature set is included.

New features

- › Sensor address read back
- › Short mode range setting, focusing on the half of the magnetic range, ensuring higher accuracy
- › Higher update frequency allows for an application field that requires faster update speed
- › Angular mode (for x and y read-out only)

Applications

- › Anti tempering protection in smart meters
- › Joysticks e.g. for medical equipment, cranes, CCTV-control, game consoles
- › Control elements e.g. white goods multifunction knobs

www.infineon.com/3dmagnetic

3D magnetic sensors

TLE493D-A2B6/W2B6 for automotive low power applications

Infineon's TLE493D-x2B6 enables for all kind of automotive control element applications within the passenger compartment or under the hood with a temperature range of -40 to +125°C, with linear magnetic range requirements up to ±160 mT.



Features

- › 3D magnetic sensing
- › Integrated temperature sensing
- › 2.8 to 3.5 V operating supply voltage
- › Low current consumption
 - 0.007 µA in power-down mode
 - 10 µA in ultralow power mode
 - Up to 10 power modes
- › Digital output via a 2-wire standard I2C interface
- › Bx, By and Bz linear field measurement ±160 mT
- › AEC-Q100 qualified
- › 12-bit data resolution for each measurement direction
- › Various resolution options from 67 µT/LSB to 134 µT
- › Operating temperature range from -40 to +125°C

Product	Temperature range	Qualification	Linear magnetic range	Resolution	I _{DD}	Update rate	Wake-up	Package	Ordering code
TLE493D-A2B6	-40 ... 125°C	AEC-Q100	±160 mT (min)	130 µT/LSB (65 µT/LSB) ¹⁾	7 nA – 3.3 mA	10 Hz – 8.4 kHz	No	TSOP6	SP001689848
TLE493D-W2B6 A0 TLE493D-W2B6 A1 TLE493D-W2B6 A2 TLE493D-W2B6 A3	-40 ... 125°C	AEC-Q100	±160 mT (min) ±100 mT (min)	130 µT/LSB (65 µT/LSB) ¹⁾	7 nA – 3.3 mA	0.05 Hz – 8.4 kHz	Yes	TSOP6	SP001655334 SP001655340 SP001655344 SP001655348

1) Half range mode

The XENSIV™ sensor TLE493D-A2B6 features include a sensor address read-back feature for additional communication verification, a half range mode focusing to half of the magnetic range, ensuring higher accuracy and an angular mode (for x and y readout only).

With the TLE493D-W2B6 A0-A3, a 3D sensor has been developed, which includes an enhanced dynamic wake up feature. Four pre-programmed address options (A0-A3) will be available, enabling for a fast start-up initialization, when used in I²C bus configurations. It also includes enhanced test options, and a safety documentation is available to enable the usage of this sensor in the context of ASIL B systems.

Applications

- › Control elements for infotainment/navigation systems, air conditions, multifunctional steering wheels, seat controls
- › Top column modules e.g. direction indicator, wiper control
- › Gear stick position sensing

www.infineon.com/3dmagnetic

Magnetic speed sensors

Easy-to-use, robust and cost-effective sensors for speed measurement

Infiniteon's Hall- and GMR-based magnetic speed sensors are designed to measure speed in safety and powertrain applications such as speedometers, ABS, camshafts/crankshafts and automatic transmissions. They are also used in similar applications in the industrial sector. The sensors use a ferromagnetic gear tooth or encoder structure to measure linear or rotational speed and position. Hall sensor measuring rotational speed with a gear tooth and a magnetic encoder wheel. The majority of sensors also feature additional benefits such as integrated capacitors (C-types) for high EMC robustness and the highest levels of ESD protection.

Modern powertrain systems rely on magnetic speed sensors, along with automotive pressure sensors, to achieve the required CO2 targets and smart powertrain solutions. Infineon offers a broad variety of magnetic speed sensors for camshaft, crankshaft and transmission applications.

TLE4922

Highly robust, easy-to-use mono-Hall speed sensor with twist-independent mounting

This sensor is specially designed to provide an easy-to-use, robust and cost-effective solution for vehicle or industrial speed sensing applications. The TLE4922 can, therefore, be back-biased using a simple, low-cost bulk magnet, while providing a good air gap performance and switching accuracy. Its hidden adaptive hysteresis and calibration algorithm enable good accuracy over air gap jumps and immunity to vibration and run-out events.

Features

- › Large operating air gap capability
- › Twist-independent mounting
- › Hidden adaptive hysteresis
- › Low current consumption
- › Reverse magnetic polarity capability
- › Advanced protection technology
 - Reverse voltage protection at VS-pin
 - Short-circuit protection
 - Overtemperature protection
- › Wide operating temperature ranges of $-40^{\circ}\text{C} \leq T_j \leq \pm 150^{\circ}\text{C}$
- › High ESD robustness up to ± 4 kV HBM
- › 3-wire PWM voltage interface

Applications

- › Two-wheeler
- › Automotive vehicle speed



TLE4929

Fully programmable crankshaft sensor

The TLE4929 is an active Hall sensor ideally suited for crankshaft applications and similar industrial applications, such as speedometer or any speed sensor with high accuracy and low jitter capabilities.

Features

- › Differential Hall speed sensor to measure speed and position of tooth/pole wheels
- › Switching point in the middle of the tooth enables backward compatibility
- › Robustness over magnetic stray-field due to differential sensing principle
- › Digital output signal with programmable output-protocol including diagnosis interface
- › Direction detection and stop-start-algorithm
- › High accuracy and low jitter
- › High sensitivity enable large air gap
- › End-of-line programmable to adapt engine parameters
- › Can be used as a differential camshaft sensor
- › Automotive operating temperature range

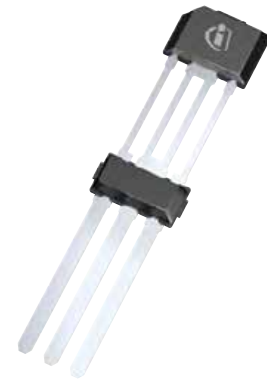

Product	Automotive	Industrial	Sensor technology	AEC-Q100 qualified	RoHS	HAL free	Product status
TLE4922	✓	✓	Mono-Hall	✓	✓	✓	In production
TLE4929	✓	✓	Differential Hall	✓	✓	✓	In production

Sensor 2GO kits

Infineon's solutions for quick evaluation

Smallest, fully featured sensor 2GO evaluation kits for current, low-cost rotational speed, 3D magnetic sensors and angle sensors with optional joystick adapter, rotation knob, linear slider and out-of-shaft adapter, as well as digital barometric air pressure sensor and XENSIV™ MEMS microphones.

- › Plug-and-measure evaluation board
- › First measurements possible within minutes
- › Various mechanical adapters for 3D magnetic sensor available for quick evaluation

Infineon's XENSIV™ sensor 2GO kits are budget-priced evaluation boards that are already equipped with a sensor combined with an ARM® Cortex®-M0 CPU. The sensor 2GO kits provide a complete set of onboard devices, including an onboard debugger. Build your own application and gadget with the sensor 2GO kits. Our 2GO kits are ready-to-use, plug-and-play boards.

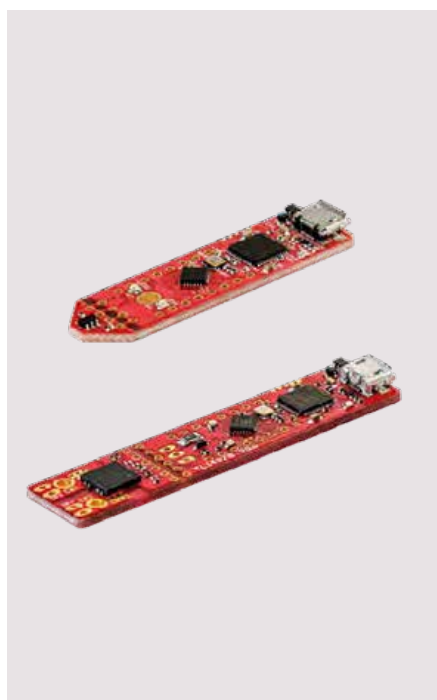

3D magnetic sensor 2GO kit features

- › We offer three different derivatives
 - TLE493D-A2B6 (three dimensional magnetic sensor)
 - TLE493D-W2B6 (three dimensional magnetic sensor)
 - TLV493D-A1B6 (three dimensional magnetic sensor)
- › XMC1100 (ARM® Cortex™-M0 based)
- › Onboard J-Link Lite debugger (realized with XMC4200 microcontroller)
- › Power over USB (micro USB), ESD and reverse current protection
- › GUI for free download

Current sensor 2GO kit features

- › TLI4970-D050T4 (current sensor with digital interface)
- › XMC1100 (ARM® Cortex®-M0 based)
- › Onboard J-link lite debugger (realized with XMC4200 microcontroller)
- › Power over USB (micro USB), ESD and reverse current protection
- › GUI for free download



Speed sensor 2GO kit features

- › Budget-priced evaluation board for speed sensing
- › Complete speed sensor incl. back-bias magnet, fixing and cable
- › TLE4922 (active mono cell Hall sensor)
- › XMC1100 (ARM® Cortex™-M0 based)
- › Onboard J-Link Lite debugger (realized with XMC4200 microcontroller)
- › Power over USB (micro USB), ESD and reverse current protection
- › GUI based tool for real in-application evaluation for free download



Add on components for 3D magnetic sensor 2GO kit

Out of shaft adapter for angle measurements

Product information:

- › Easy mounting on all 3D magnetic sensor 2GO kits
- › First angle measurement in out-of-shaft configuration
- › Three different out-of-shaft configurations possible
- › Magnetic rotation bar with ring magnet included

Joystick adapter

Product information:

- › Easy mounting on 3D magnetic sensor 2GO
- › First magnetic joystick measurements within minutes
- › The user manual in the download area explains usage, mounting and functionality

Rotate knob

Product information:

- › Rotate and push button control element
- › Simulates rotational and angle sensing movements
- › The user manual in the download area precisely explains usage, mounting and functionality and functionality

Linear slider

- › Easy mounting on 3D Magnetic Sensor 2GO
- › First magnetic linear evaluations within minutes
- › Flexible setup: adaptable airgaps, two different magnetic strengths/ materials and distance limiters



Getting Started Box IoT

For fast, flexible and easy prototyping - never been easier

A box consists of:

- > XENSIV™ magnetic position sensor TLV493D-A1B6
- > Rotate knob – add-on component for 3D magnetic Hall sensor
- > Joystick - add-on component for 3D magnetic Hall sensor
- > OPTIGA™ Trust E – hardware security chip
- > XENSIV™ pressure sensor DPS310 for consumer
- > XMC 1100 Bootkit – 32-bit microcontroller based on ARM® Cortex®-M form factor compatible with Arduino Uno
- > XMC2Go (qty 2) – 32-bit microcontroller based on ARM® Cortex®-M in Shield2Go form factor
- > XENSIV™ magnetic current sensor TLI4970-D050T4 with integrated current rail
- > XENSIV™ MEMS microphone IM69D130
- > ESP32 – Wemos form factor including BLE and WIFI functionality
- > Dual-adapter Trust X – adapter for Infineon Shield2Go board with Wemos form factor equipped with OPTIGA™ Trust X
- > Triple-adapter – adapter for Infineon Shield2Go board form factor compatible with Arduino Uno (alternatively: Grove Base_Shield_V2)
- > USB-cable and soldering connectors

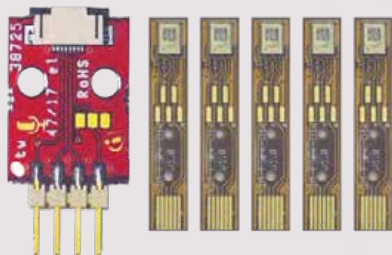

MEMS 2GO

The flex evaluation kit allows simple and easy evaluation of XENSIV™ MEMS microphone IM69D130. The flex board can be easily connected to audio testing setup. The evaluation kit includes five IM69D130 mounted on flex board and one adapter board.

Features

- > Quick and easy evaluation of XENSIV™ MEMS microphones
- > Flex dimensions: 25 x 4.5 mm
- > Adapter dimensions: 20 x 15 mm

Shield2Go boards and My IoT adapter

Easy evaluation for shorter time to market

Infineon's Shield2Go boards offer a unique customer and evaluation experience. The boards are equipped with a featured Infineon's XENSIV™ sensor and come with a ready-to-use software library for Arduino. Customers can now develop their own system solutions by combining Shield2Go boards with Infineon My IoT adapter, which serves as a gateway to external hardware solutions and popular IoT evaluation platforms such as Arduino and Raspberry PI. All this enables the fastest evaluation and development of an IoT system on the market.



TLV493D 3DSense Shield2Go

Featured product: XENSIV™ magnetic position sensor TLV493D-A1B6
OPN: S2GO3DSENSETLV493DTOBO1

Interfaces:

I²C
 SPI
 INT
 PWM
 UART
 Analog



TLI4970 Current Sense Shield2Go

Featured product: XENSIV™ magnetic current sensor TLI4970-D050T4
OPN: S2GOCURSENSETLI4970TOBO1

Interfaces:

I²C
 SPI
 INT
 PWM
 UART
 Analog

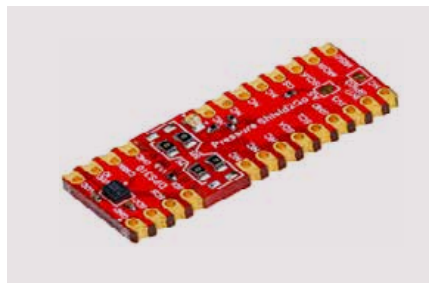

DPS310 Pressure Shield2Go

Featured product: XENSIV™ pressure sensor DPS310
OPN: S2GOPRESSUREDPS310TOBO1

Interfaces:

I²C
 SPI
 INT
 PWM
 UART
 Analog

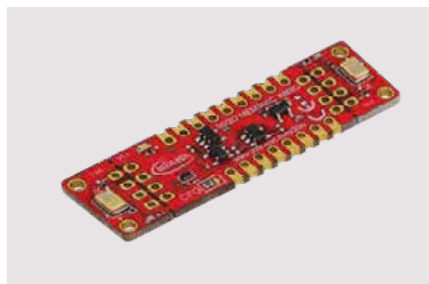

IM69D130 Microphone Shield2Go

Featured product: XENSIV™ MEMS microphone IM69D130
OPN: S2GOMEMSMICIM69DTOBO1

Interfaces:

I²C
 SPI
 INT
 PWM
 UART
 Analog



The My IoT adapter board enables designers to combine the Shield2Go boards into a system. Infineon's flexible evaluation boards are compatible with the existing solutions on the market. My IoT adapters act as gateways to external hardware solutions such as Arduino, one of the most common IoT evaluation and prototyping platforms.
OPN: MYIOTADAPTERTOBO1

www.infineon.com/2go

www.infineon.com/sensors2go



Infineon support for sensors

Useful links and helpful information

Further information, datasheets and documents

www.infineon.com/sensors

www.infineon.com/microphones

www.infineon.com/magnetic-sensors

www.infineon.com/current-sensor

www.infineon.com/hall-switches

www.infineon.com/angle-sensors

www.infineon.com/3dmagnetic

www.infineon.com/pressuresensor

www.infineon.com/24GHz

www.infineon.com/pressure

2GO evaluation kits

www.infineon.com/sensors2go

Online simulation tools

www.infineon.com/cms/en/product/sensor/#!simulation

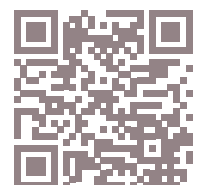

Packages

Surface mount device (SMD) technology

DDPAK (TO-252-2)		DDPAK (TO-252)		DDPAK 5-pin (TO-252)		HDSOP-10-1		HDSOP-22-1		D²PAK (TO-263)	
2	9.9 x 6.5 x 2.3	3	9.9 x 6.5 x 2.3	5	9.9 x 6.5 x 2.3	10	20.96 x 6.5 x 2.3	22	20.96 x 15.0 x 2.3	3	15.0 x 10.0 x 4.4
D²PAK (TO-263-2)		TO263-7-11		TO263-7-12		TO263-7-13		D²PAK 7-pin (TO-263)		TO-Leadless (TOLL)	
2	15.0 x 10.0 x 4.4	7	15.0 x 10.0 x 4.4	7	15.0 x 10.0 x 4.4	7	15.0 x 10.0 x 4.4	7	15.0 x 10.0 x 4.4	8	11.68 x 9.9 x 2.3
SC59		SOT-23		SOT-23-5		SOT-23-6		SOT-89		SOT-223	
3	3.0 x 2.8 x 1.1	3	2.9 x 2.4 x 1.0	5	2.9 x 1.6 x 1.3	6	2.9 x 1.6 x 1.3	3	4.5 x 4.0 x 1.5	4	6.5 x 7.0 x 1.6
SOT223-3-1		SOT-323		SOT-363		TSOP6		PQFN 2x2		PQFN 2x2 dual	
3	6.5 x 7.0 x 1.6	3	2.0 x 2.1 x 0.9	6	2.0 x 2.1 x 0.9	6	2.9 x 2.5 x 1.1	6	2.0 x 2.0 x 0.9	6	2.0 x 2.0 x 0.9
PQFN 3.3x3.3		SuperSOT8		SuperSOT8 dual		SuperSOT8 fused leads		TDSON-8-47		TDSON-10-2	
8	3.3 x 3.3 x 1.0	8	5.15 x 6.15 x 1.0	8	5.15 x 6.15 x 1.0	8	5.15 x 6.15 x 1.0	8	5.15 x 6.15 x 1.0	10	3.0 x 3.0 x 0.9
TDSON-10-7		TDSON-8-25 fused leads		TISON-8		TISON-8 (power stage 5x6)		TISON-8-4 (Power Block)		TSON-8-1	
10	3.0 x 3.0 x 0.9	8	3.3 x 3.3 x 1.0	8	7.0 x 7.0 x 1.0	8	5.0 x 6.0 x 1.0	8	5.0 x 6.0 x 1.0	8	3.0 x 3.0 x 1.0
TSON-8-3		ThinPAK 5x6 (TSON-8)		TSON-10		TSNP-6-13		ThinPAK 8x8 (VSON-4)		VDSO-8	
8	5.0 x 6.0 x 1.0	8	5.0 x 5.0 x 1.0	10	3.3 x 3.3 x 1.0	6	1.5 x 1 x 0.375	4	8.0 x 8.0 x 1.0	8	4.0 x 4.0 x 0.9
WSON-6-1		WSON-8-3		WSON-10		DirectFET™ Small Can		DirectFET™ Medium Can		DirectFET™ Large Can	
6	3 x 3 x 0.75	8	3 x 3 x 0.75	10	4.0 x 4.0 x 0.8	V	4.8 x 3.8 x 0.65	V	6.3 x 4.9 x 0.65	V	9.1 x 6.98 x 0.71
Package (JEITA-code)											
X	L x W x H										
 pin-count V = Variable number of pins											
All dimensions in mm											

All products are RoHS Compliant.



IQFN-27-2		IQFN-30 (DrMOS 4x4)		IQFN-31 (DrMOS 5x5)		IQFN-36		IQFN-39		IQFN-40	
27	3.3 x 6.0 x 0.9	30	4.0 x 4.0 x 1.0	31	5.0 x 5.0 x 0.8	36	7.5 x 6.0 x 0.9	39	5.0 x 6.0 x 0.9	40	6.0 x 6.0 x 0.8
											
SO-8/SO-8 dual		SO-16/12		SO-14		SO-16		SO-18		DSO-12	
8	5.0 x 6.0 x 1.75	12	10.0 x 6.0 x 1.75	14	8.75 x 6.0 x 1.75	16	10.0 x 6.0 x 1.75	18	12.8 x 10.3 x 2.65	12	10.3 x 7.8 x 2.6 (max)
											
DSO-16-30 (300 mil)		DSO-24		SSOP-24		TDSO-16		SO-19		SO-20	
16	10.3 x 7.5 x 2.35	24	10.5 x 15.6 x 2.65 (max)	24	6 x 8.65 x 1.75 (max)	16	5.0 x 6.0 x 1.2	19	12.8 x 10.3 x 2.65	20	12.8 x 10.3 x 2.65
											
DSO-28		SO-36		TSSOP-28		TSSOP-48		LFBGA-516-5		LFBGA-292-6	
28	18.1 x 10.3 x 2.65	36	15.9 x 11.0 x 3.5	28	9.7 x 6.4 x 1.2	48	12.5 x 6.1 x 1.1	516	25.3 x 25.3 x 2.8	292	17.3 x 17.3 x 2.35
											
BGA-416-26		TFLGA-13-1		LQFP-176-22		LQFP-144-22		TQFP-144-27		TQFP-100-23	
416	27.3 x 27.3 x 3.2	13	5 x 5 x 0.96	176	26.7 x 26.7 x 2.1	144	22.4 x 22.4 x 2.2	144	18.7 x 18.7 x 1.6	100	14.5 x 14.5 x 1.5
											
TQFP-80-7		VQFN-40-13		VQFN-48-60		VQFN-48-78 (LTI)		VQFN-56-5/-6		Package (JEITA-code)	
80	12.6 x 12.6 x 1.5	40	5 x 5 x 0.85	48	6 x 6 x 0.85	48	7 x 7 x 0.85	56	7 x 7 x 0.9	X	L x W x H
										I pin-count V = Variable number of pins All dimensions in mm	

Through-hole device (THD) technology

IPAK (TO251)		IPAK SL (TO251 SL)		I²PAK (TO262)		TO220 real 2-pin		TO220 2-pin		TO220 3-pin	
3	15.5 x 6.5 x 2.3	3	10.7 x 6.5 x 2.3	3	25.1 x 10 x 4.4	2	29.15 x 10.0 x 4.4	2	29.1 x 9.9 x 4.4	3	29.15 x 10.0 x 4.4
											
TO220 FullPAK		TO220 FullPAK Narrow Lead		TO220 FullPAK Wide Creepage		TO220-6-46		TO220-6-47		TO247	
3	29.6 x 10.5 x 4.7	3	29.6 x 10.5 x 4.7	3	28.85 x 11 x 4.7	6	21.7 x 9.9 x 4.4	6	26.1 x 9.9 x 4.4	3	40.15 x 15.9 x 5.0
											
TO247-3-AI		TO247 4-pin		DIP-7		DIP-8		DIP-14		DIP-20	
3	41.3 x 10.9 x 5.18	4	40.15 x 15.9 x 5.0	7	9.52 x 8.9 x 4.37	8	9.52 x 8.9 x 4.37	14	19.5 x 8.9 x 4.37	20	24.6 x 9.9 x 4.2
											
Super220		Super247		SSO-3-9		SSO-3-10		SSO-4-1		TO92S-3-1	
3	28.25 x 10.5 x 4.5	3	34.6 x 15.6 x 5	3	A: 3.71 x 5.34 x 1 B: 2.68 x 5.34 x 1.2	3	4.06 x 1.5 x 4.05	4	5.34 x 1.0 x 3.71	3	4.0 x 1.52 x 3.15
											
TO92S-3-2		Package (JEITA-code)									
3	4.0 x 1.52 x 3.15	X	L x W x H								
		 pin-count V = Variable number of pins All dimensions in mm									



Infineon support for packages

Useful links and helpful information

Further information, datasheets and documents

www.infineon.com/packages

Videos

www.infineon.com/mediacenter





Infineon powerful support

Useful links and helpful information

General support

www.infineon.com/support
www.infineon.com/wheretobuy
www.infineon.com/quality
www.infineon.com/packages
www.infineon.com/green
www.infineon.com/opn

Request reliability (FIT) data

http://infineon-community.com/FIT_1

Tools, desks and more

www.infineon.com/solutionfinder
www.infineon.com/lightdesk
www.infineon.com/evaluationboards
www.infineon.com/webinars

Register for the Newsletter4Engineers

<http://infineon-community.com/Newsletter4Engineers>

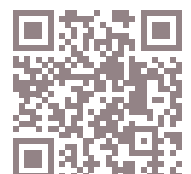

A world leader
in semiconductor solutions



Our vision

We are the link between the
real and the digital world.

Our values

We commit
We partner
We innovate
We perform

Our mission

We make life
easier, safer
and greener.

Part of your life. Part of tomorrow.

Where to buy

Infiniteon distribution partners and sales offices:

www.infineon.com/wheretobuy

Service hotline

Infiniteon offers its toll-free 0800/4001 service hotline as one central number, available 24/7 in English, Mandarin and German.

- > Germany 0800 951 951 951 (German/English)
- > China, mainland 4001 200 951 (Mandarin/English)
- > India 000 800 4402 951 (English)
- > USA 1-866 951 9519 (English/German)
- > Other countries 00* 800 951 951 951 (English/German)
- > Direct access +49 89 234-0 (interconnection fee, German/English)

* Please note: Some countries may require you to dial a code other than "00" to access this international number.
Please visit www.infineon.com/service for your country!



Mobile product catalog

Mobile app for iOS and Android.

www.infineon.com

Published by
Infineon Technologies Austria AG
9500 Villach, Austria

© 2019 Infineon Technologies AG.
All Rights Reserved.

Order number: B131-I0773-V1-7600-EU-EC-P
Date: 02/2019

Please note!

THIS DOCUMENT IS FOR INFORMATION PURPOSES ONLY AND ANY INFORMATION GIVEN HEREIN SHALL IN NO EVENT BE REGARDED AS A WARRANTY, GUARANTEE OR DESCRIPTION OF ANY FUNCTIONALITY, CONDITIONS AND/OR QUALITY OF OUR PRODUCTS OR ANY SUITABILITY FOR A PARTICULAR PURPOSE. WITH REGARD TO THE TECHNICAL SPECIFICATIONS OF OUR PRODUCTS, WE KINDLY ASK YOU TO REFER TO THE RELEVANT PRODUCT DATA SHEETS PROVIDED BY US. OUR CUSTOMERS AND THEIR TECHNICAL DEPARTMENTS ARE REQUIRED TO EVALUATE THE SUITABILITY OF OUR PRODUCTS FOR THE INTENDED APPLICATION.

WE RESERVE THE RIGHT TO CHANGE THIS DOCUMENT AND/OR THE INFORMATION GIVEN HEREIN AT ANY TIME.

Additional information

For further information on technologies, our products, the application of our products, delivery terms and conditions and/or prices, please contact your nearest Infineon Technologies office (www.infineon.com).

Warnings

Due to technical requirements, our products may contain dangerous substances. For information on the types in question, please contact your nearest Infineon Technologies office.

Except as otherwise explicitly approved by us in a written document signed by authorized representatives of Infineon Technologies, our products may not be used in any life-endangering applications, including but not limited to medical, nuclear, military, life-critical or any other applications where a failure of the product or any consequences of the use thereof can result in personal injury.