

LM193/LM293/LM393/LM2903 Low Power Low Offset Voltage Dual Comparators

General Description

The LM193 series consists of two independent precision voltage comparators with an offset voltage specification as low as 2.0 mV max for two comparators which were designed specifically to operate from a single power supply over a wide range of voltages. Operation from split power supplies is also possible and the low power supply current drain is independent of the magnitude of the power supply voltage. These comparators also have a unique characteristic in that the input common-mode voltage range includes ground, even though operated from a single power supply voltage.

Application areas include limit comparators, simple analog to digital converters; pulse, squarewave and time delay generators; wide range VCO; MOS clock timers; multivibrators and high voltage digital logic gates. The LM193 series was designed to directly interface with TTL and CMOS. When operated from both plus and minus power supplies, the LM193 series will directly interface with MOS logic where their low power drain is a distinct advantage over standard comparators.

- Eliminates need for dual supplies
- Allows sensing near ground
- Compatible with all forms of logic
- Power drain suitable for battery operation

Features

- Wide supply Voltage range
single or dual supplies 2.0V to 36V
 $\pm 1.0V$ to $\pm 18V$
- Very low supply current drain (0.4 mA) — independent of supply voltage
- Low input biasing current 25 nA
- Low input offset current ± 5 nA
and maximum offset voltage ± 3 mV
- Input common-mode voltage range includes ground
- Differential input voltage range equal to the power supply voltage
- Low output saturation voltage, 250 mV at 4 mA
- Output voltage compatible with TTL, DTL, ECL, MOS and CMOS logic systems

Advantages

- High precision comparators
- Reduced V_{OS} drift over temperature

Schematic and Connection Diagrams

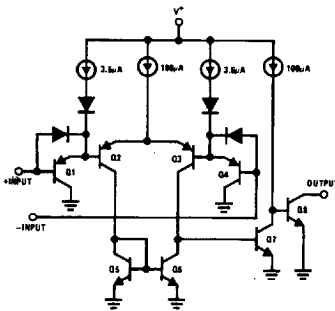

Metal Can Package

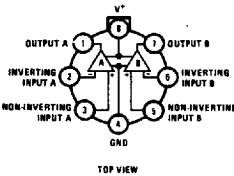

Order Number **LM193H**,
LH193H/883*,
LM193AH, LM193AH/883,
LM293H, LM293AH, LM393H
or LM393AH
See NS Package Number H08C

Dual-In-Line Package

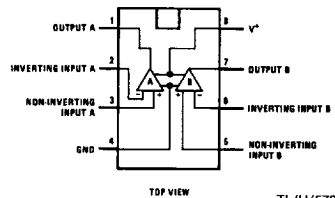

Order Number **LM193J/883***,
LM193AJ/883,
LM393J, LM393AJ,
LM393M, LM2903M, LM393N,
LM2903J or LM2903N
See NS Package Number J08A,
M08A or N08E

*Also available per JM38510/11202

Absolute Maximum Ratings

If Military/Aerospace specified devices are required, please contact the National Semiconductor Sales Office/Distributors for availability and specifications. (Note 10)

Supply Voltage, V^+ 36V
 Differential Input Voltage (Note 8) 36V
 Input Voltage -0.3V to +36V
 Input Current ($V_{IN} < -0.3V$) (Note 3) 50 mA
 Power Dissipation (Note 1) 780 mW
 Molded DIP Metal Can 660 mW
 Small Outline Package 510 mW
 Output Short-Circuit to Ground (Note 2) Continuous

Operating Temperature Range LM393/LM393A 0°C to +70°C
 LM293/LM293A -25°C to +85°C
 LM193/LM193A -55°C to +125°C
 LM2903 -40°C to +85°C
 Storage Temperature Range -65°C to +150°C
 Lead Temperature (Soldering, 10 seconds) +260°C
 Soldering Information 260°C
 Dual-In-Line Package Soldering (10 seconds) 215°C
 Small Outline Package Vapor Phase (60 seconds) 220°C
 Infrared (15 seconds)
 See AN-450 "Surface Mounting Methods and Their Effect on Product Reliability" for other methods of soldering surface mount devices.
 ESD rating (1.5 kΩ in series with 100 pF) 1300V

Electrical Characteristics ($V^+ = 5V, T_A = 25^\circ C$, unless otherwise stated)

Parameter	Conditions	LM193A		LM293A, LM393A		LM193		LM293, LM393		LM2903		Units
		Min	Typ	Max	Min	Typ	Max	Min	Typ	Max	Min	
Input Offset Voltage (Note 9)		1.0	2.0	1.0	2.0	1.0	5.0	1.0	5.0	2.0	7.0	mV
Input Bias Current	$I_{IN}(+)$ or $I_{IN}(-)$ with Output in Linear Range, $V_{CM} = 0V$ (Note 5)	25	100	25	250	25	100	25	250	25	250	nA
Input Offset Current	$I_{IN}(+) - I_{IN}(-)$ $V_{CM} = 0V$	3.0	25	5.0	50	3.0	25	5.0	50	5.0	50	nA
Input Common Mode Voltage Range	$V^+ = 30V$ (Note 6)	0	$V^+ - 1.5$	0	$V^+ - 1.5$	0	$V^+ - 1.5$	0	$V^+ - 1.5$	0	$V^+ - 1.5$	V
Supply Current	$V^+ = 5V$	0.4	1	0.4	1	0.4	1	0.4	1	0.4	1.0	mA
	$V^+ = 36V$	1	2.5	1	2.5	1	2.5	1	2.5	1	2.5	mA
Voltage Gain	$R_L \geq 15 k\Omega, V^+ = 15V$	50	200	50	200	50	200	50	200	25	100	V/mV
	$V_O = 1V$ to $11V$											
Large Signal Response Time	$V_{IN} = TTL$ Logic Swing, $V_{REF} = 1.4V$ $V_{RL} = 5V, R_L = 5.1 k\Omega$	300		300		300		300		300		ns
Response Time	$V_{RL} = 5V, R_L = 5.1 k\Omega$ (Note 7)	1.3		1.3		1.3		1.3		1.5		μs
Output Sink Current	$V_{IN}(-) = 1V, V_{IN}(+) = 0, V_O \leq 1.5V$	6.0	16	6.0	16	6.0	16	6.0	16	6.0	16	mA
Saturation Voltage	$V_{IN}(-) = 1V, V_{IN}(+) = 0, I_{SINK} \leq 4 mA$	250	400	250	400	250	400	250	400	250	400	mV
Output Leakage Current	$V_{IN}(-) = 0, V_{IN}(+) = 1V, V_O = 5V$	0.1		0.1		0.1		0.1		0.1		nA

Electrical Characteristics (V⁺ = 5V) (Note 4)

Parameter	Conditions	LM193A		LM293A, LM393A		LM193		LM293, LM393		Units	
		Min Typ	Max	Min Typ	Max	Min Typ	Max	Min Typ	Max	Min Typ	Max
Input Offset Voltage	(Note 9)		4.0		4.0		9		9		mV
Input Offset Current	$I_{IN(+)} - I_{IN(-)}$, $V_{CM} = 0V$		100		150		100		150		nA
Input Bias Current	$I_{IN(+)}$ or $I_{IN(-)}$ with Output in Linear Range, $V_{CM} = 0V$ (Note 5)		300		400		300		400		nA
Input Common Mode Voltage Range	$V^+ = 30V$ (Note 6)	0	$V^+ - 2.0$	0	$V^+ - 2.0$	0	$V^+ - 2.0$	0	$V^+ - 2.0$	0	$V^+ - 2.0$
Saturation Voltage	$V_{IN(-)} = 1V$, $V_{IN(+)} = 0$, $ I_{SINK} \leq 4 mA$		700		700		700		700		mV
Output Leakage Current	$V_{IN(-)} = 0$, $V_{IN(+)} = 1V$, $V_O = 30V$		1.0		1.0		1.0		1.0		μA
Differential Input Voltage	Keep All V_{IN} 's $\geq 0V$ (or V^- , if Used), (Note 8)		36		36		36		36		V

Note 1: For operating at high temperatures, the LM393/LM393A and LM2903 must be derated based on a 125°C maximum junction temperature and a thermal resistance of 170°C/W which applies for the device soldered in a printed circuit board, operating in a still air ambient. The LM193/LM193A/LM293/LM293A must be derated based on a 150°C maximum junction temperature. The low bias dissipation and the "ON-OFF" characteristic of the outputs keeps the chip dissipation very small ($P_D \leq 100 mW$), provided the output transistors are allowed to saturate.

Note 2: Short circuits from the output to V^+ can cause excessive heating and eventual destruction. When considering short circuits to ground, the maximum output current is approximately 20 mA independent of the magnitude of V^+ . **Note 3:** This input current will only exist when the voltage at any of the input leads is driven negative. It is due to the collector-base junction of the input PNP transistors becoming forward biased and thereby acting as input diode clamps. In addition to this diode action, there is also lateral NPN parasitic transistor action on the IC chip. This transistor action can cause the output voltages of the comparators to go to the V^+ voltage level (or to ground for a large overdrive) for the time duration that an input is driven negative. This is not destructive and normal output states will re-establish when the input voltage, which was negative, again returns to a value greater than $-0.3V$.

Note 4: These specifications are limited to $-55^\circ C \leq T_A \leq +125^\circ C$, for the LM193/LM193A, with the LM293/LM293A all temperature specifications are limited to $-25^\circ C \leq T_A \leq +85^\circ C$ and the LM393/LM393A temperature specifications are limited to $0^\circ C \leq T_A \leq +70^\circ C$. The LM2903 is limited to $-40^\circ C \leq T_A \leq +85^\circ C$.

Note 5: The direction of the input current is out of the IC due to the PNP input stage. This current is essentially constant, independent of the state of the output so no loading change exists on the reference or input lines. **Note 6:** The input common-mode voltage or either input signal voltage should not be allowed to go negative by more than 0.3V. The upper end of the common-mode voltage range is $V^+ - 1.5V$ at 25°C, but either or both inputs can go to 36V without damage, independent of the magnitude of V^+ .

Note 7: The response time specified is for a 100 mV input step with 5 mV overdrive. For larger overdrive signals 300 ns can be obtained, see typical performance characteristics section. **Note 8:** Positive excursions of input voltage may exceed the power supply level. As long as the other voltage remains within the common-mode range, the comparator will provide a proper output state. The low input voltage state must not be less than $-0.3V$ (or 0.3V below the magnitude of the negative power supply, if used).

Note 9: At output switch point, $V_O = 1.4V$, $R_S = 0\Omega$, with V^+ from 5V to 30V, and over the full input common-mode range (0V to $V^+ - 1.5V$), at 25°C.

Note 10: Refer to RETS193AX for LM193AH military specifications and to RETS193X for LM193H military specifications.

Typical Performance Characteristics LM193/LM293/LM393, LM193A/LM293A/LM393A

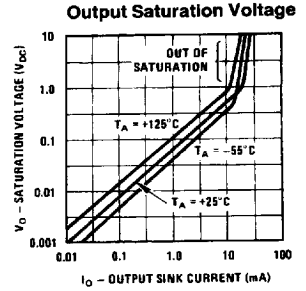
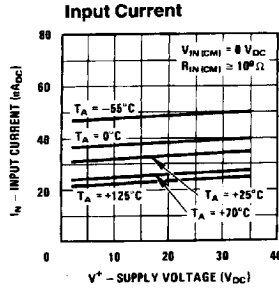
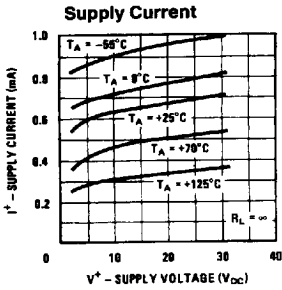

Response Time for Various Input Overdrives—Negative Transition

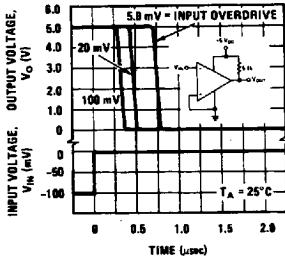

Response Time for Various Input Overdrives—Positive Transition

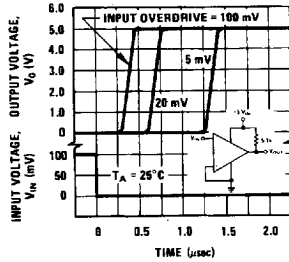

TL/H/5709-3

Typical Performance Characteristics LM2903

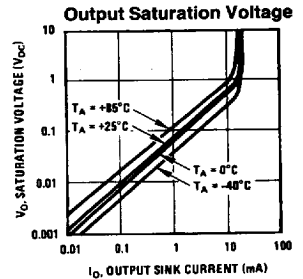
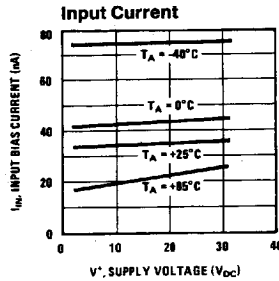
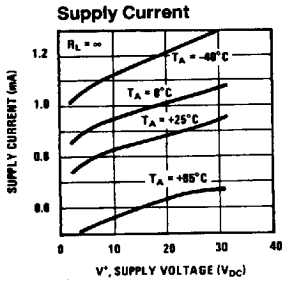

Response Time for Various Input Overdrives—Negative Transition

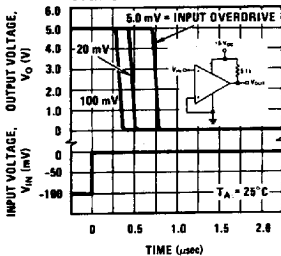

Response Time for Various Input Overdrives—Positive Transition

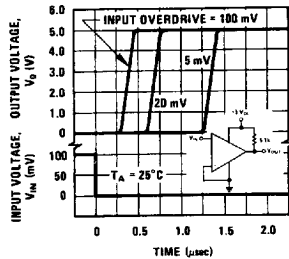

TL/H/5709-4

Application Hints

The LM193 series are high gain, wide bandwidth devices which, like most comparators, can easily oscillate if the output lead is inadvertently allowed to capacitively couple to the inputs via stray capacitance. This shows up only during the output voltage transition intervals as the comparator change states. Power supply bypassing is not required to solve this problem. Standard PC board layout is helpful as it reduces stray input-output coupling. Reducing the input resistors to $< 10 \text{ k}\Omega$ reduces the feedback signal levels and finally, adding even a small amount (1.0 to 10 mV) of positive feedback (hysteresis) causes such a rapid transition that oscillations due to stray feedback are not possible. Simply socketing the IC and attaching resistors to the pins will cause input-output oscillations during the small transition intervals unless hysteresis is used. If the input signal is a pulse waveform, with relatively fast rise and fall times, hysteresis is not required.

All pins of any unused comparators should be grounded.

The bias network of the LM193 series establishes a drain current which is independent of the magnitude of the power supply voltage over the range of from $2.0 \text{ V}_{\text{DC}}$ to 30 V_{DC} .

It is usually unnecessary to use a bypass capacitor across the power supply line.

The differential input voltage may be larger than V^+ without damaging the device (see Note 8). Protection should be provided to prevent the input voltages from going negative more than $-0.3 \text{ V}_{\text{DC}}$ (at 25°C). An input clamp diode can be used as shown in the applications section.

The output of the LM193 series is the uncommitted collector of a grounded-emitter NPN output transistor. Many collectors can be tied together to provide an output OR'ing function. An output pull-up resistor can be connected to any available power supply voltage within the permitted supply voltage range and there is no restriction on this voltage due to the magnitude of the voltage which is applied to the V^+ terminal of the LM193 package. The output can also be used as a simple SPST switch to ground (when a pull-up resistor is not used). The amount of current which the output device can sink is limited by the drive available (which is independent of V^+) and the β of this device. When the maximum current limit is reached (approximately 16 mA), the output transistor will come out of saturation and the output voltage will rise very rapidly. The output saturation voltage is limited by the approximately $60\Omega \text{ } r_{\text{SAT}}$ of the output transistor. The low offset voltage of the output transistor (1.0 mV) allows the output to clamp essentially to ground level for small load currents.

Typical Applications ($V^+ = 5.0 \text{ V}_{\text{DC}}$)

Basic Comparator

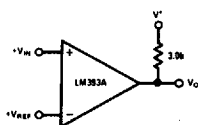

Driving CMOS

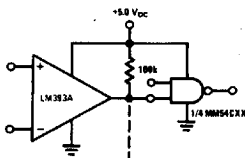

Driving TTL

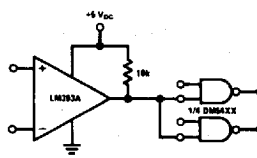

TL/H/5709-2

Typical Applications (Continued)

Squarewave Oscillator

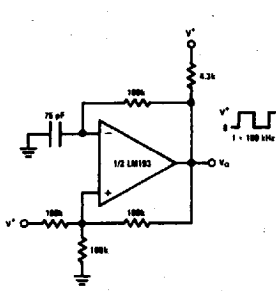

Pulse Generator

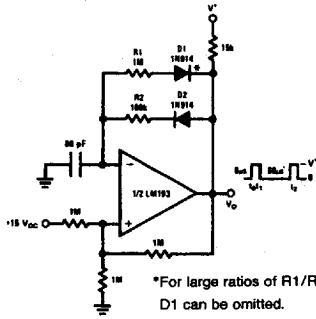

Crystal Controlled Oscillator

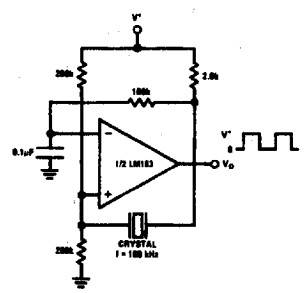

Two-Decade High-Frequency VCO

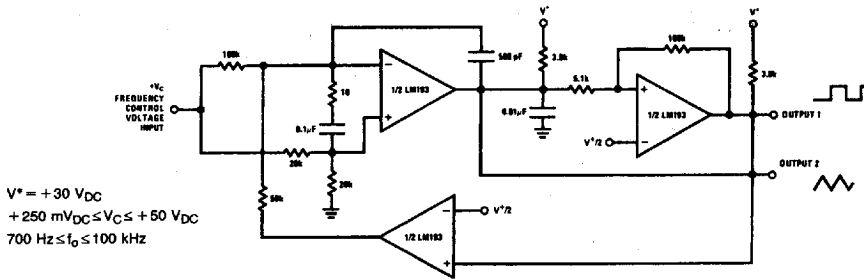

Basic Comparator

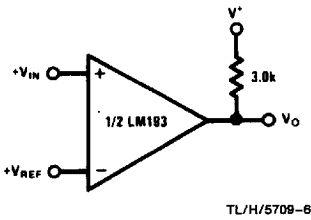

TL/H/5709-8

Non-Inverting Comparator with Hysteresis

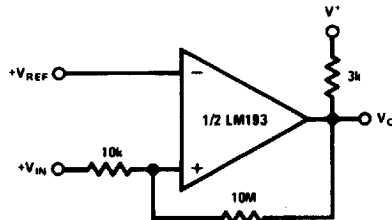

TL/H/5709-9

Inverting Comparator with Hysteresis

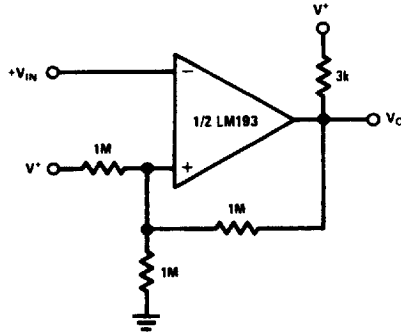

TL/H/5708-10

TL/H/5709-5

Typical Applications (Continued)

Output Strobing

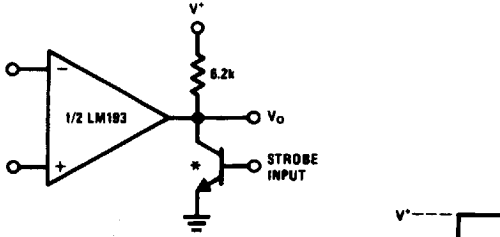

* OR LOGIC GATE
WITHOUT PULL-UP RESISTOR

TL/H/5709-11

Large Fan-In AND Gate

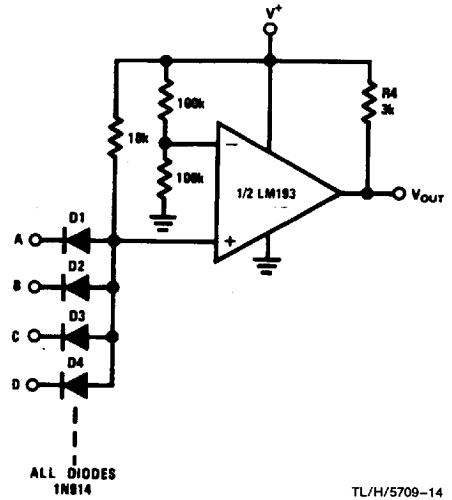

ALL DIODES
1N914

TL/H/5709-14

AND Gate

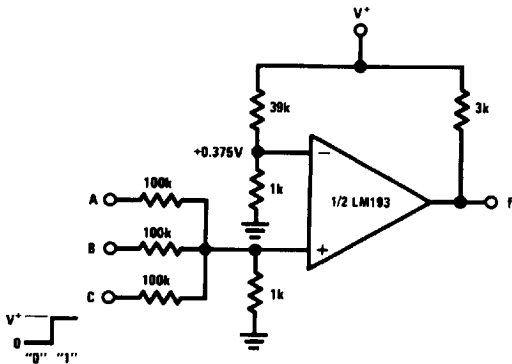

TL/H/5709-12

Limit Comparator

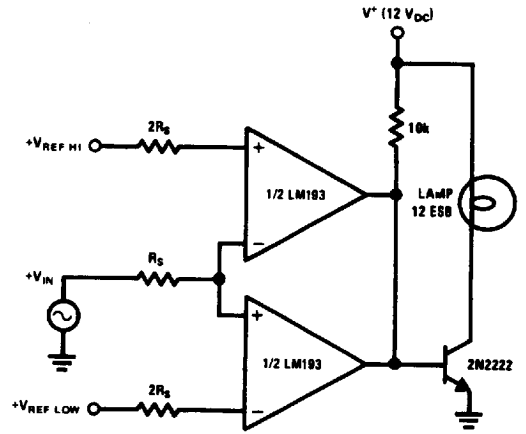

TL/H/5709-15

OR Gate

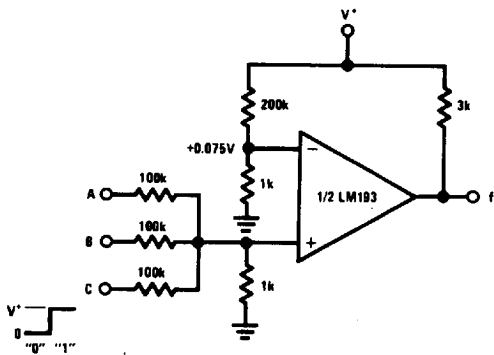

TL/H/5709-13

Comparing Input Voltages of Opposite Polarity

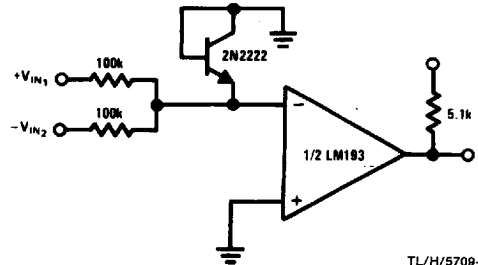

TL/H/5709-16

Typical Applications (Continued)

ORing the Outputs

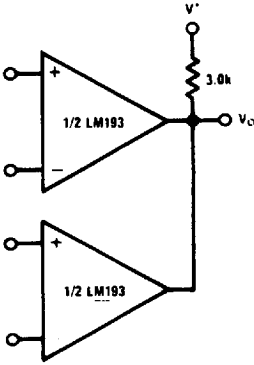

TL/H/5709-17

Zero Crossing Detector (Single Power Supply)

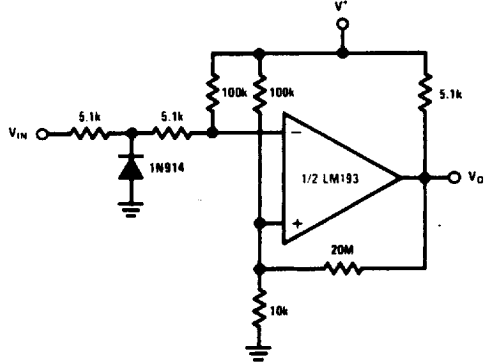

TL/H/5709-21

One-Shot Multivibrator

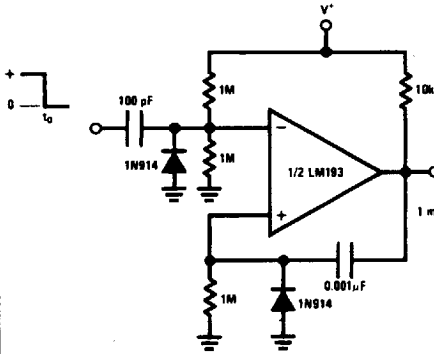

TL/H/5709-22

Bi-Stable Multivibrator

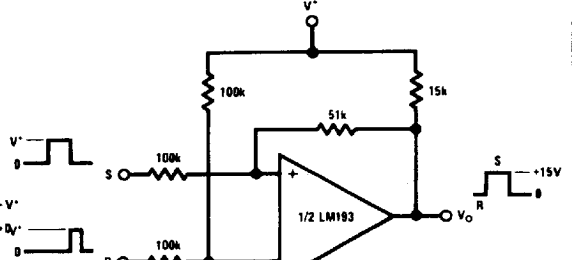

TL/H/5709-24

One-Shot Multivibrator with Input Lock Out

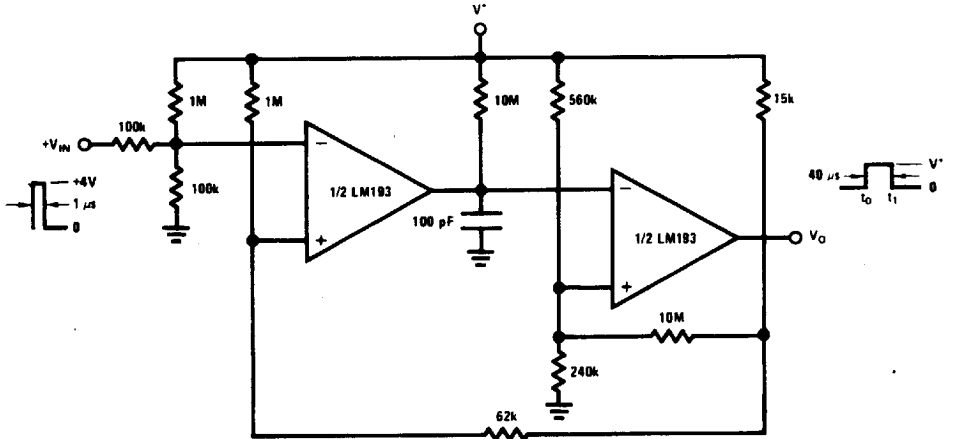

TL/H/5709-23

Typical Applications (Continued) ($V^+ = V_{DC}$)

Time Delay Generator

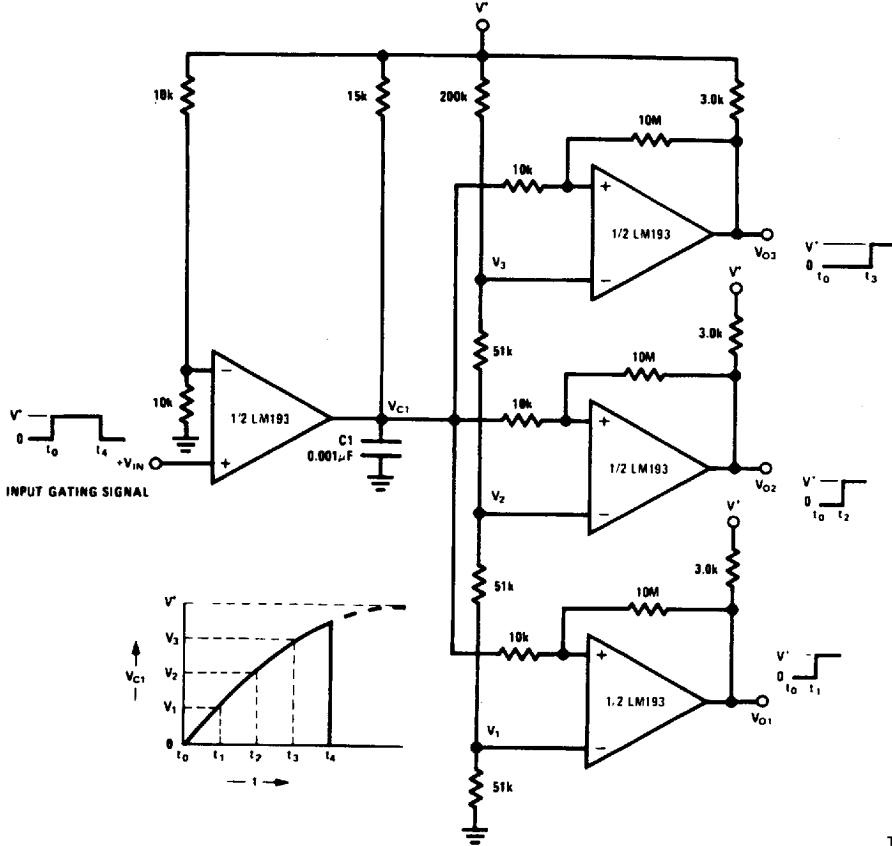

TL/H/5709-7

Split-Supply Applications ($V^+ = +15 V_{DC}$ and $V^- = -15 V_{DC}$)

MOS Clock Driver

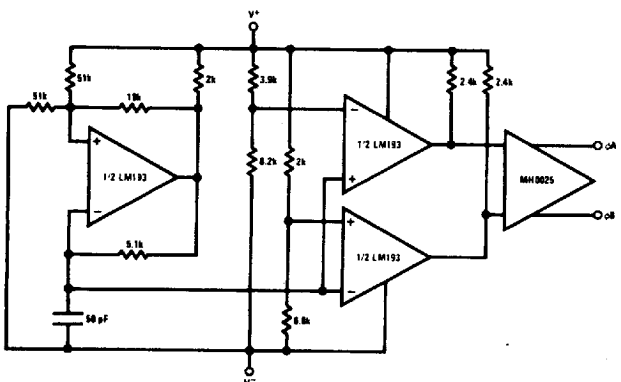

Zero Crossing Detector

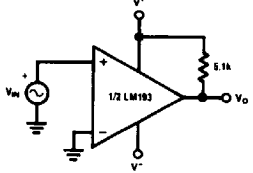

Comparator With a Negative Reference

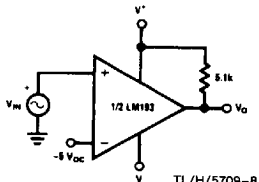

TL/H/5709-8