



KBJ401G THRU KBJ410G

CLASS PASSIVATED SINGLE - PHASE BRIDGE RECTIFIERS



FEATURES

- * Plastic Package has Underwriters Laboratory Flammability Classification 94V - 0
- * Ideal for printed circuit boards
- * Glass passivated chip junction
- * High Surge Current Capability
- * High temperature Soldering Guaranteed
260°C/10 Seconds, 0.375(9.5mm) lead length

MECHANICAL DATA

- * Case: Moulded plastic body over passivated junctions

Reverse Voltage 100 to 1000 Volts
Forward Current 4.0A

KBJ

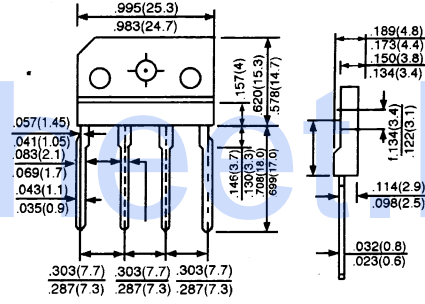

MAXIMUM RATINGS AND ELECTRICAL CHARACTERISTICS

Rating at 25°C ambient temperature unless otherwise specified.
Single phase, half wave, 60 Hz, resistive or inductive load.
For capacitive load, derate current by 20%

TYPE NUMBER	SYMBOLS	KBJ 401G	KBJ 402G	KBJ 404G	KBJ 406G	KBJ 408G	KBJ 410G	UNITS
Maximum Recurrent Peak Reverse Voltage	V_{RRM}	100	200	400	600	800	1000	V
Maximum RMS Voltage	V_{RMS}	70	140	280	420	560	700	V
Maximum D. C Blocking Voltage	V_{DC}	100	200	400	600	800	1000	V
Maximum average forward $T_C = 100^\circ\text{C}$ (NOTE 1) rectified output current $T_A = 40^\circ\text{C}$ (NOTE 2)	$I_{F(AV)}$				4 2.3			A
Peak forward surge current 8.3ms single half sine - wave superimposed on rated load (JEDEC Method)	I_{FSM}				120			A
Maximum instantaneous forward drop per element at 4.0A	V_F				1.1			V
Maximum DC revers current at rated $T_A = 25^\circ\text{C}$ DC blocking Voltage per element $T_A = 125^\circ\text{C}$	I_R				5.0 500			μA
Typical junction capacitance (NOTE 3)	C_J				45			pF
Typical thermal resistance per leg (NOTE 1)	$R_{\theta JC}$				5.5			$^\circ\text{C}/\text{W}$
Operation Temperate and storage temperature range	T_J, T_{STG}				- 65 to + 150			$^\circ\text{C}$

NOTES: 1. Unite case mounted on 2.95 x 2.95 x 0.06" (75 x 75 x 1.6mm) Cu plate heatsink
2. Unit mounted on P. C. B 0.5 x 0.5" (12 x 12mm) copper pads and 0.375" (9.5mm) lead length
3. Measured at 1MHz and applied reverse Voltage of 4.0 Volts

RATINGS AND CHARACTERISTIC CURVES

KBJ401G THRU KBJ410G

FIG. 1 - FORWARD CURRENT DERATING CURVE

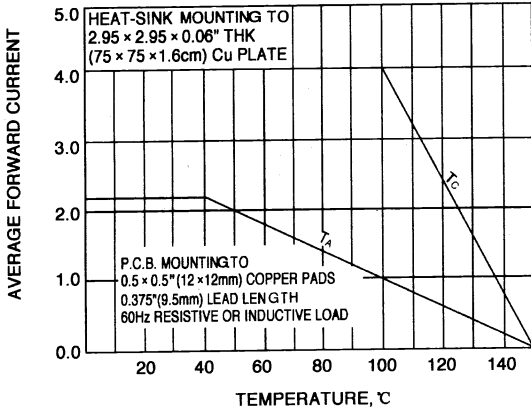

FIG. 2 - MAXIMUM NON-REPETITIVE FORWARD SURGE CURRENT - PER ELEMENT

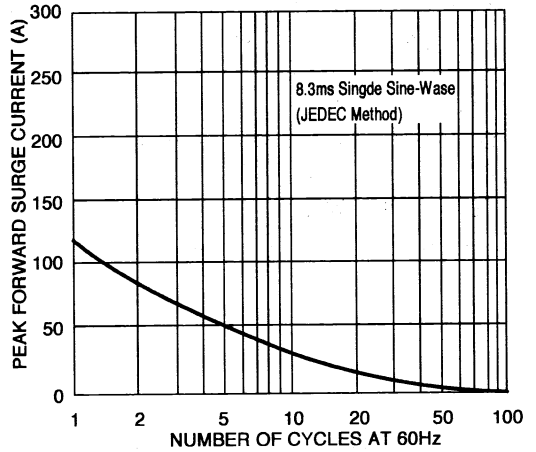

FIG. 3 - TYPICAL INSTANTANEOUS FORWARD CHARACTERISTICS - PER ELEMENT

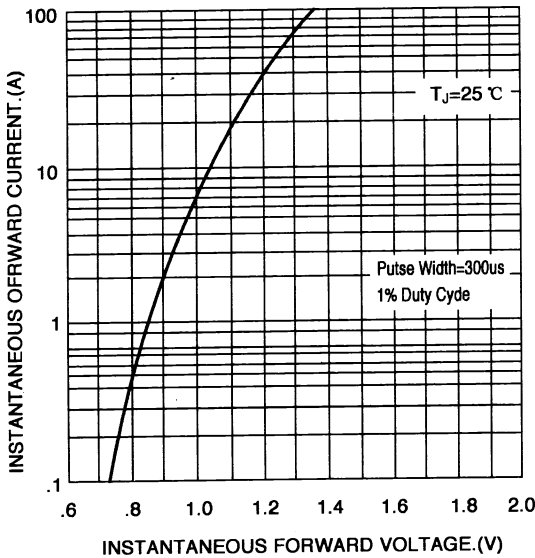

FIG. 4 - TYPICAL REVERSE CHARACTERISTICS - PER ELEMENT

