

REVISION L

PATENT NUMBERS
5713755 / 5961339

DIMENSIONS ARE IN INCHES		UNLESS OTHERWISE NOTED		TOLERANCES ARE:	
ONE PLACE DECIMALS ± .1 [2.54]	THREE PLACE DECIMALS ± .005 [.127]	ANGLES	± 2°		
TWO PLACE DECIMALS ± .01 [.254]	FOUR PLACE DECIMALS ± .0020 [.051]				

TITLE:	1mm DUAL ROW STRIP ASSEMBLY	DWG NO:	MLE-1XX-XX-X-DV-X
		SHEET 1 OF 3	

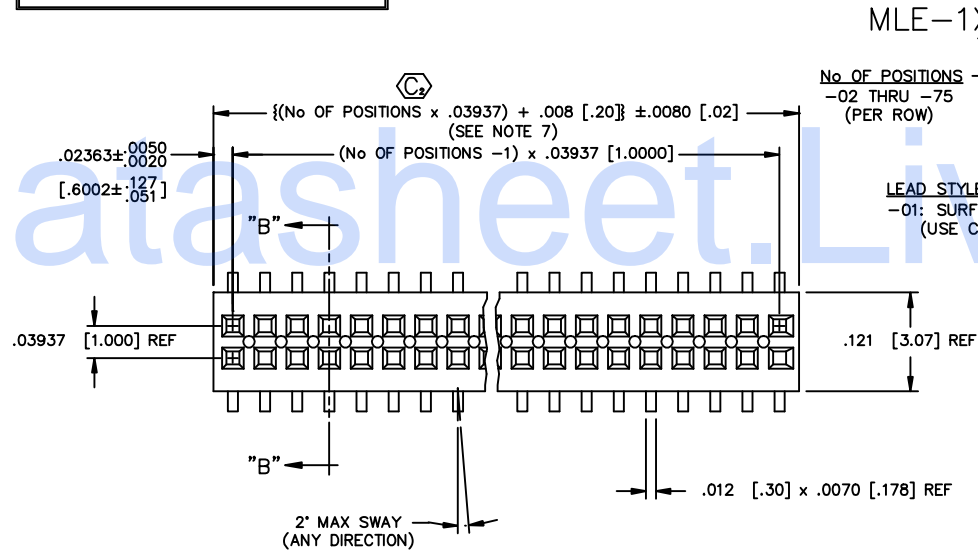

MLE-1XX-XX-X-DV-X

No OF POSITIONS
-02 THRU -75
(PER ROW)

LEAD STYLE
-01: SURFACE MOUNT
(USE C-99-01-X)

OPTION

- A: ALIGNMENT PIN (SEE FIG. 2 & 3, SHT. 2)
(USE MLE-XX-D-XX)
(MOLDED TO POSITION OR STAKED)
(SAMTEC DISCRETION WHICH -A PIN IS USED)
(MOLDED 3 POSITION MIN. SEE FIG. 2, SHT 2)
(STAKED 7 POSITION MIN. SEE FIG. 3, SHT 2)
- P: PICK & PLACE PAD (SEE FIG. 4, SHT 2)
(USE MPP-01)
(AVAILABLE ON POSITIONS -05 THRU -75 ONLY)
- K: POLYAMIDE FILM PAD (SEE FIG. 5, SHT 2)
(-05 POSITIONS MINIMUM)
- TR: TAPE & REEL (SEE FIG. 6, SHT. 3)

BODY SPECIFICATION

-DV: DOUBLE VERTICAL (USE MLE-XX-D)

PLATING SPECIFICATION

-G: .000010 GOLD ON .000050 TO .000100 NICKEL

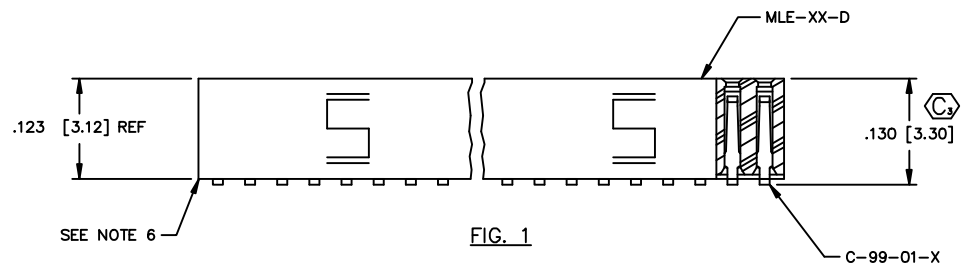
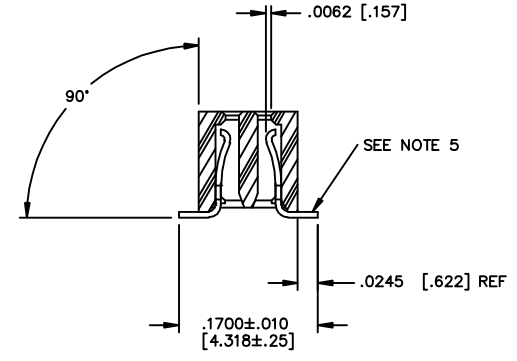

FIG. 1



SECT. "B-B"

NOTES:

1. MINIMUM PUSHOUT FORCE: .5 lb.
2. COPLANARITY; POS -02 THRU -26: .004 [.10]
POS -27 THRU -75: .006 [.15]
3. (C) REPRESENTS A CRITICAL DIMENSION.
4. POSITIONS -05 THRU -75 TO BE PACKAGED IN TUBES;
POSITIONS -02 THRU -04 TO BE LAYER PACKAGED.
5. BURR ALLOWANCE: .003 [.08] MAX
6. .010 [.25] MAX CUT FLASH NOT TO PROTRUDE BELOW LEADS.
7. WILL LOSE TWO POSITIONS FOR EVERY CUT MADE. MAXIMUM CUT FLASH TO BE .010 [.25] WITH NO FLASH IN HOLES OR EXTENDING BELOW LEADS.
8. ENDWALL THICKNESS TO BE SYMMETRICAL WITHIN .005 [.13].

PROPRIETARY NOTE
THIS DOCUMENT CONTAINS INFORMATION CONFIDENTIAL AND PROPRIETARY TO SAMTEC INC. AND SHALL NOT BE REPRODUCED OR TRANSMITTED TO OTHERS OR USED FOR ANY PURPOSE OTHER THAN THAT FOR WHICH IT WAS OBTAINED WITHOUT THE EXPRESS WRITTEN CONSENT OF SAMTEC INC.

MATERIAL:
INSULATOR:
BLACK LIQUID CRYSTAL POLYMER

TERMINAL:
BERYLLIUM COPPER

samtec

520 PARK EAST BLVD. NEW ALBANY, INDIANA 47150
PHONE (812) 944-6733 P.O. BOX 1147
CODE 55322

MADE BY:
D PURVIS 01-07-97

MLE-1XX-XX-X-DV-X
SHEET 1 OF 3