

### INTRODUCTION

The CH2100 is a full function, fully approved V.22bis 2400bps modem module. It is hermetically encapsulated and has a footprint that is less than one square inch. This makes the CH2100 unique in size, performance and reliability. The CH2100 interfaces directly to the telephone line utilizing its built in PSTN line interface. The modem is completely intelligent and is controlled by and will communicate via the five volt serial transmit and receive data pins exclusively. The CH2100 uses the standard AT commands and status words for command and control. No additional external pin connections are required. Even though all other vestigial modem signals have been eliminated, the CH2100 can communicate with any other commercially available modem up to and including 56Kbps modems. The CH2100 supports asynchronous operation at 2400bps, 1200bps, and 300bps to CCITT and Bell standards. Through-hole or surface mount pins are available. The user may select from standard temperature range or extended temperature range versions. The CH2100 is FCC part 68 approved (which is conveyed to the user), is UL1950 and CSA C22.2 950 compliant and is approvable in Canada to CSA CS-03 Part I.

### GENERAL DESCRIPTION

The CH2100 has very few external pins (when compared to conventional modems) making the CH2100 extremely easy to interface to the user's application hardware. Unique to the CH2100 architecture is the assumption that an intelligent host is processing the transmit and receive data, providing the AT commands for control and interpreting the status information supplied by the CH2100. Pins such as DCD, DSR, RST, CTS, HS - which are commonly found on conventional modems - are functionally duplicated with the AT command structure and have been eliminated. This minimizes the external hardware interface to the CH2100 while simultaneously consolidating control of the modem into one place: the user or host controller. All communication to the CH2100 is conveyed on the TXD (or transmit) pin with respect to ground. All communication from the CH2100 is received by the host controller on the RXD (or receive) pin with respect to ground. For those users that require access to the traditional pin set or who do not have an intelligent host controller available for the CH2100, Cermetek recommends use of one of our many conventional modems which offer a broad range of externally controlled functions that collectively provide solutions for virtually every modem application. Please access the Cermetek web site at [www.cermetek.com](http://www.cermetek.com) for other data sheets.

### FEATURES

- Supports Standards CCITT V.22bis, V.22, Bell 212, and Bell 103
- FCC Part 68 approved and CSA CS-03 Part I approvable
- AT Command structure - with extensions
- 1500VAC RMS isolation barrier, 2122V peak surge protection
- Single 5 volt operation

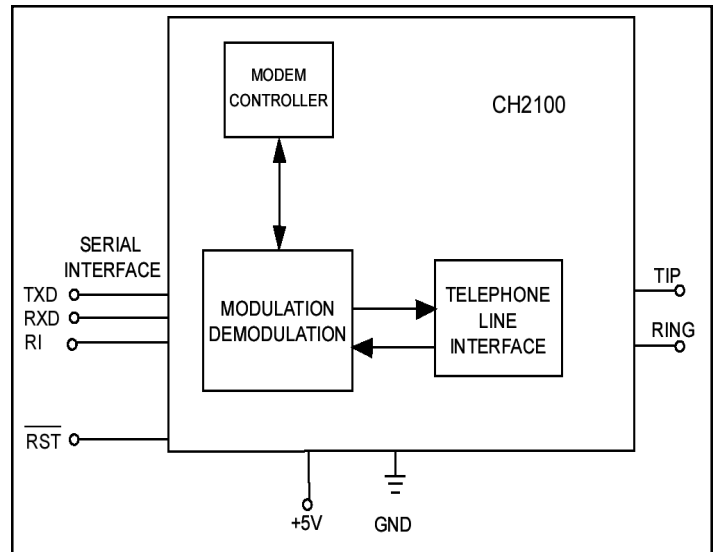

Figure 1. Functional Block Diagram of CH2100.

- Low power operation with automatic reduced power standby mode
- Automatic adaptive and fixed compromise equalization
- Test modes and diagnostics
- Size: 0.86"x1.10"x0.53" (nominal)
- Fully encapsulated
- UL1950 and CS22.2 950 compliant approval pending
- Extended Temperature: -40°C to 85°C

### DESCRIPTION OF FUNCTIONAL BLOCKS AND DISCUSSION OF BASIC OPERATIONS

Figure 1 contains a functional block drawing of the CH2100. The CH2100 is a highly integrated, full-function modem, comprised of a modulator/demodulator, controller, and an FCC Part 68 approved PSTN line interface DAA (Data Access Arrangement).

#### Modulation/Demodulation and Modem Controller.

These functions are provided by a monolithic modem integrated circuit. This IC has built-in facilities to accommodate integrated AT command control and contains the necessary resident interfaces for general communication and routing to the DAA.

#### Telephone Interface or DAA.

The CH2100 is designed to meet North American telephone standards as set by FCC Part 68 (USA) and CSA CS-03 Part I (CANADA). Among the more critical parameters, the telephone line interface is designed to meet 1500VAC RMS and 2122 volts peak surge isolation. Consequently, the CH2100 satisfies U.S. and Canadian requirements, and will meet other international approval agency requirements that specify this level of isolation.

CH2100 comes with FCC Part 68 approval and is shipped from the factory with an FCC Part 68 label indicating the registration number and ringer equivalent. This label should be prominently displayed on the end product.

With the exception of the U.S., most countries (including Canada) require submission of the final product or system containing the CH2100 to the appropriate governing regulatory agency for approval. Typically this is accomplished by submitting the final end product to an independent test house or consultant for evaluation. The test house/consultant then forwards the test results and applicable documents to the regulatory agency. Call Cermetek for a list of consultants.

## SUPPORTED FEATURES

### “AT” Command Set.

A 40-character command line is supported. The command line starts with AT and may contain standard or enhanced commands. A summary is available in this data sheet while a detailed description is available from our web site.

### Serial Host Interface.

The serial interface signals conform to V.24 (EIA-232). See pin description.

### Transmission Speed.

In normal operation, the originating modem initiates the call and attempts to connect to the answering modem at a speed established by the originating modem's controller prior to call initiation. This is referred to as the Initial Trained Rate. Upon receiving the call, the answering modem will attempt to connect to the originating modem at its Initial Trained Rate.

If these two rates are identical, the connection is made. If the speeds differ, the answering modem must adjust its rate or terminate the call. Table 1 indicates the connection rate that will result when the calling modem's Initial Trained Rate and the answering modem's Initial Trained Rate are different.

Note that a 2400 baud connection rate will only result if both modems are initially set at 2400 baud.

### Speed and Parity Selection.

Prior to call initiation, the host controller trains the modem to the host speed (2400, 1200, or 300 bps) and parity (odd, even, mark, space, or none) via a host-initiated training sequence. This training also sets the speed of the data for originate calls. The CH2100 will automatically adjust to the originator's speed when answering calls.

The CH2100 matches the host's parity when it returns status messages to the host. During a data connection, however, the modem passes parity through without interpretation or alteration.

### Sleep Mode.

To minimize power consumption, the CH2100 includes a power down feature called Sleep Mode. When activated, the CH2100 will automatically enter Sleep Mode after 0 to 254 seconds of inactivity. The inactivity delay is selected using the ATS24 command. The CH2100 is delivered from the factory with a 5 second inactivity delay enabled (i.e., ATS24=5). The CH2100 returns to normal operation when a ring signal is received or upon an input low signal on the TXD pin. ATS24 = 255 disables the Sleep Mode and is the default if no value is set in register S24. In Sleep Mode, power is reduced to approximately 50% of normal operating power.

### Ring Indicator (RI).

The  $\overline{RI}$  pin toggles low when the CH2100 detects an incoming call. The  $\overline{RI}$  pin is TTL compliant and can be utilized to activate external circuitry including the external  $\overline{RST}$  pin.

## Power Supply.

The CH2100 modem module is a complex set of sub-systems. During the course of normal operation the CH2100 decodes analog signals from the telephone line that are in the millivolt range. Steps must be taken by the user to guarantee that power supply noise on all supply lines, including ground, does not exceed 50 mV peak to peak. Any frequency between 20 kHz and 150 kHz must be less than 500 micro volts peak. If necessary, use dedicated power and ground planes. Failure to provide such operating conditions could cause the CH2100 to malfunction or to function erratically.

The CH2100 requires a single +5V  $\pm$ 5% supply. It is recommended that by-pass capacitors be placed on the power supply as close to the modem's supply input as practical. It is recommended that a 10  $\mu$ F or greater Tantalum capacitor in parallel with a 0.01 $\mu$ F ceramic capacitor be used.

## MODEM CONTROL

The CH2100 modem may be controlled by sending serial ASCII command sequences. The commands are sent to the modem serially on the TXD pin. After execution of a received command, the modem returns a serial status message that can be read on pin RXD. This message indicates command completion status. Refer to Table 3 for a complete list of result codes.

### Reset on Power Up.

The user can also reset the modem externally by applying a low-going reset pulse to the  $\overline{RST}$  pin for at least 10ms after the +5V power supply has stabilized. This can be accomplished in one of two methods. In the Reset on Power Up method, a resistor/capacitor network is used. Referring to figure 2, the reset pulse, with the appropriate delays, are generated automatically when 5V are applied simultaneously to the CH2100 and to the Reset on Power Up circuit. Delay sending commands to CH2100 for 200ms after reset has been initiated to allow the CH2100 to properly reconfigure.

### TTL Controller Reset.

To reset the modem externally using the second reset method, TTL Controller Reset, the modem must be powered up and the 5V supply must have stabilized prior to utilizing this method. Referring to the TTL Controller Reset circuit in figure 2, a 10msec low-going pulse is sent from the controller through the inverter. Delay sending commands to CH2100 for 200ms after reset has been initiated to allow the CH2100 to properly reconfigure.

**Table 1. Connection Rates**

Answering Modem Initial Trained Rate	Connection Rate Resulting When Calling Modem Initial Trained Rate is:		
	300	1200	2400
300	300	1200	1200
1200	300	1200	1200
2400	300	1200	2400

**Table 2. CH2100 Pin Descriptions**

PIN	NAME	TYPE	FUNCTION
1	TIP	I/O	Directly connects to the telephone line's Tip lead through a user supplied RJ-11C jack. Tip and Ring are not polarity sensitive and may be reversed.
2	RING	I/O	Directly connects to the telephone line's Ring lead through a user supplied RJ-11C jack. Tip and Ring are not polarity sensitive and may be reversed.
3	$\overline{\text{RI}}$	O	<b>RING INDICATION.</b> A LOW for 2 seconds indicates that the local telephone line is ringing. this signal follows the frequency of the ringing signal (normally about 20 or 30 Hz for 2 seconds).
4	GND	-	<b>GROUND.</b> Note: Noise should be less than 50mV peak to peak.
5	RXD	O	<b>RECEIVE DATA.</b> Serial Receive data output. Received marking or binary 1 condition is indicated by HIGH. RXD for communication to host controller from CH2100.
6	TXD	I	<b>TRANSMIT DATA.</b> Serial transmit data input. Marking, or a binary 1 condition, is transmitted when a HIGH is asserted. TXD for communication from host controller to CH2100.
7	$\overline{\text{RST}}^1$	I	<b>RESET</b> input. Active LOW. This input must be asserted LOW for at least 10 ms to reset the modem. RESET is then returned HIGH for normal operation. If no system reset is available, attach a 330K ohm resistor to 5V and a 0.1uf capacitor to ground to create a reset.
8	VCC	-	<b>POWER SUPPLY.</b> 5 Volts $\pm$ 5% Note: Noise should be less than 50mV peak to peak.

Note: (1) If VCC has a slow power up ramp time, the internal reset may be ineffective.

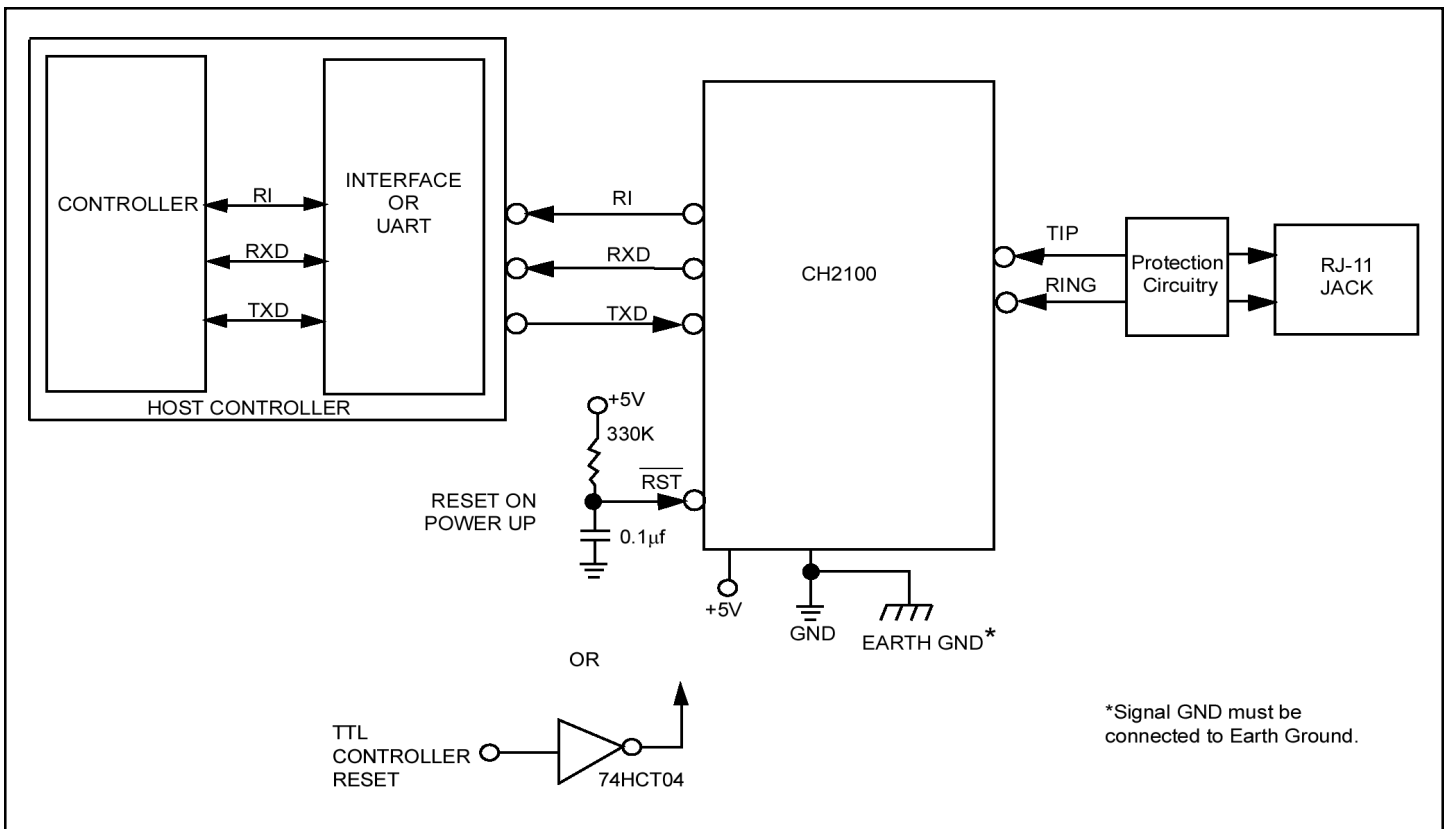

**Figure 2. CH2100 Application Diagram.**

## Training the Modem.

Each modem must be trained to match its host's speed and parity so that it is able to recognize serial asynchronous commands sent to it by the host UART. The host must retrain the modem each time a reset signal is applied on RST or after a RESET serial command has been issued.

## Modem Training Command Sequence.

The CH2100 is trained by sending it the following sequence:

Enter: **AT[CR]**

Where: **A** and **T** may be either upper or lower case but must be the same case.

**[CR]** represents carriage return

The "AT" sequence is referred to as an attention sequence. The CH2100 will respond with one of the following status messages, depending on whether it is optioned for abbreviated or English status messages.

Result: **0[CR]** (Abbreviated form)

Result: **[CR][LF]OK[CR][LF]** (English form)

Where: **[CR]** represents carriage return (ASCII 13 or HEX 0D).

**[LF]** represents line feed (ASCII 10 or HEX 0A).

The modem is now in idle mode and is ready to accept commands.

An alternate attention sequence "A/" may be sent which behaves much like the AT sequence except that it causes the previously entered command specified with an AT prefix to be executed. When given, it must be in upper case ASCII. No carriage return is needed.

## THE COMMAND FORMAT

Typical commands consist of three elements: the attention sequence, the commands themselves, and a terminating carriage return.

### AT [commands] [CR].

Where: **[AT]** represents attention sequence.

**[commands]** represents command strings.

**[CR]** represents carriage return (ASCII 13 or HEX 0D).

When entering commands to the modem, the backspace character-control-H (ASCII 8 or HEX 08) can be used to edit mistakes.

**Table 3. Summary of Result Codes and Their Meanings**

Result Codes	Status Messages	Meaning
0	OK	Command executed
1	CONNECT	Carrier detected at 300 bps
2	RING	Ring detected
3	NO CARRIER	Did not detect carrier
4	ERROR	Entry error
5	CONNECT 1200	Carrier detected at 1200 bps
6	NO DIAL TONE	Off-hook, but no response after 5 seconds
7	BUSY	Busy signal detected
10	CONNECT 2400	Carrier detected at 2400 bps

"AT" and "A/" may not be edited however. Multiple commands may be placed in the command line. A command line may be as long as 40 characters, excluding the letters AT. By way of example, the command below instructs the CH2100 to configure itself to not echo characters when in command mode (E0) and then put itself in answer mode (A).

Enter: **ATE0A[CR]**

## AT Command Set.

The available command set is divided into four types of commands: dial modifiers, basic commands, ampersand and percent commands. Refer to the complete list in Table 5.

## AT Command Data Rate.

With the serial interface, the rate is speed sensed for parity and format.

## THE STATUS MESSAGES

The CH2100 responds with a status message after each command is executed. This status message may either be a single digit followed by a carriage return or a carriage return and line feed with a message in English, followed by a carriage return and line feed.

The basic status code subsets are enabled with the Xn command. Where n=0,1,2,3,4 establishes the result codes allowed by the user.

X0 - Result Codes 0, 1, 2, 3, 4 allowed

X1 - Result Codes 0, 1, 2, 3, 4, 5, 10 allowed

X2 - Result Codes 0, 1, 2, 3, 4, 5, 6, 10 allowed

X3 - Result Codes 0, 1, 2, 3, 4, 5, 7, 10 allowed

X4 - Result Codes 0, 1, 2, 3, 4, 5, 6, 7, 10 allowed

The CH2100 is factory set to X4, which allows all result codes.

**Table 4. CH1786 Register Summary**

Register	Function
S0	Ring to Answer On
S1	Ring Count
S2	Escape Code Character
S3	Carriage Return Character
S4	Line Feed Character
S5	Back Space Character
S6	Wait For Dial Tone
S7	Wait Time for Data Carrier
S8	Pause Time for Comma
S9	Carrier Detect Response Time
S10	Lost Carrier to Hang-up Delay
S11	DTMF Dialing Speed
S12	Escape Code Guard Time
S24	Sleep Mode Inactivity Time

## MODEM STATES

The CH2100 can be in either command mode or data mode. When the modem is idle, it is in command mode by default. When data transmission is in progress, the CH2100 is in the data mode state and will not recognize commands. To force the CH2100 to recognize commands, the host must send an "escape sequence" to the CH2100 forcing it out of data mode and into command mode.

The escape sequence consists of a “guard time” (a period where no characters are sent to the modem), followed by 3 escape characters, followed by another guard time. At powerup, the guard time is set to 1 second minimum, and the escape character is set as “+.” These two parameters can be modified via registers S12 and S2, respectively.

The CH2100 will stay off-hook with its carrier on after the escape sequence is received and it returns an OK status message when it is ready to accept commands. The CH2100 can be put into data mode by issuing the command **ATO [CR]**.

## AT COMMAND APPLICATIONS

### Dialing A Phone Number.

The Dial command takes the form Dn, where n is a string of characters. In the simplest form, n will be only the digits of the phone number to be dialed.

Example: Dial number.

Enter: **AT D1234567**

In response to this command, the CH2100 dials the telephone number “123-4567” and then waits for a carrier from the distant modem. If no carrier is detected within a given time (the default time is 30 seconds), the CH2100 automatically releases the line and sends a NO CARRIER result code. If a carrier is detected, the CH2100 gives a CONNECT result code and goes on-line, permitting communication with the distant modem.

The Dial Command may also be issued without a telephone number. ATD causes the modem to pick up the telephone line without dialing a number.

### Pause During Dialing.

When placing a call from an office with a telephone connected to a PBX, it may be necessary to dial an access code (usually the digit 9) to get an outside line. Inserting a comma in the telephone number instructs the modem to pause for a specific length of time. The factory set default pause time is 2 seconds.

Example: Dial 9, pause, dial number.

Enter: **AT DT9, 1234567**

Multiple commas may be used to generate integer multiples of the specified delay time.

### Originate a Call in Answer Mode.

The D command forces the modem into originate mode. To call an originate-only modem, dial the number and set the modem to answer mode via the R command (reverse originate). This is done by including an R at the end of the telephone number.

Example: Change modem from original-only to answer mode.

Enter: **AT DT 1234567R**

### Redial Last Number.

Use A/, the repeat command, to redial the last telephone number dialed.

### Return to Command State.

The modem can be forced to reenter the command state after dialing (without hanging up) by ending the dial command with a semicolon. This is useful when using the modem as an auto dialer.

Example: Touch-tone dial 9, pause, dial number, return for command.

Enter: **AT DT9, 1234567;**

Result: **OK**

### Automatic Answering.

The S0 register controls the number of rings that must occur before the modem answers a call. The register may range in value from 0 to 255.

S0 = 0	DO NOT ANSWER TELEPHONE
S0 = 1	ANSWER ON RING 1
S0 = 2	ANSWER ON RING 2
S0 = 3	ANSWER ON RING 3
S0 = 255	ANSWER ON RING 255

When S0 is set to 0, the modem will not auto-answer.

## CONNECTING TO THE HOST UART

Since the CH2100 communicates data serially and most host products handle data in a parallel format, a UART is needed to make parallel-to-serial and serial-to-parallel translations.

The modem is controlled by sending it serial commands over TXD and can be monitored by serial status messages returned on RXD.  $\overline{RI}$  is optionally used to monitor the ring signal.

## PHONE LINE CONNECTION GUIDELINES

- 1) The CH2100 must be mounted in the final assembly such that it is isolated from exposure to any hazardous voltages within the assembly. Adequate separation and restraint of cables and cords must be provided.
- 2) The circuitry from the CH2100 to the telephone line interface must be provided in wiring that carries no other circuitry other than that specifically allowed in the FCC rules (such as A and A1 leads).
- 3) Connection to phone line should be made through an RJ-11 jack.
- 4) PCB traces from the modem’s RING and TIP pins to the RJ-11 jack must be 0.1 inch spacing or greater to one another and 0.2 inch spacing or greater to all other traces. The traces should have a nominal width of 0.020 inches or greater.
- 5) The RING and TIP PCB traces should be as short as possible and oriented to prevent coupling other high speed or high frequency signals present on the host circuit PCB.
- 6) No additional circuitry other than that shown in Figure 6 may be connected between the modem module and the RJ-11 jack. Doing so will invalidate the FCC approval.
- 7) The CH2100, the RJ-11 jack, the interfacing circuitry and all PCB traces in between, must be contained on a PCB with a 94 V-0 flammability rating.
- 8) The supplied FCC registration label must be applied visibly on the outside of the product.
- 9) The product’s User Manual must provide the user with instructions for connection and use as recommended in the FCC Registration Section below.

## CH2100 HANDLING AND ASSEMBLY RECOMMENDATIONS

The CH2100 contains static-sensitive components and should only be handled by personnel and in areas that are properly protected against static discharge.

There are two mounting techniques that are recommended for physically connecting the CH2100 to a PCB: 1) sockets, and 2) direct soldering.

### Direct Soldering.

The CH2100 may be wave or vapor phase soldered onto circuit boards. All CH2100 products are hermetically sealed and will not be harmed by industry standard soldering processes.

### Socketing.

The socketing approach to mounting eliminates cleaning and desoldering concerns. When the socket is used, it must make a solid connection to all pins. Failure to do so will cause unreliable operation. Also, steps should be taken to assure that the module remains tightly seated in the socket after the end product is shipped. Recommended socket is CES-150-01-T-S by Samtec, 50 pin strip socket. Socketing SMD versions of the CH2100 is not recommended.

## FCC REGISTRATION

All products in the CH2100 family are registered with the FCC (Federal Communications Commission) under Part 68. To maintain the validity of the registration, you must serve notice to the end user of the product of several restrictions the FCC places on the modem and its use.

In addition to restriction notification, the FCC requires that Cermetek make all repairs to all products in the CH2100 family. If repairs are necessary after installation of the CH2100 in the end product and the end product has been delivered to the end user, the end product must be returned to the end product supplier where the CH2100 can be removed and then forwarded to Cermetek for repair. The following notice is recommended and should be included in the end product's user manual.

## FOR YOUR USER'S MANUAL

The Part 68 rules require the following (or equivalent) be provided to the end user of equipment containing a DAA:

**Type of Service:** The (insert end product name) is designed to be used on standard device telephone lines. It connects to the telephone line by means of a standard jack called the USOC RJ-11C (or USOC RJ45S). Connection to telephone-company-provided coin service (central office implemented systems) is prohibited. Connection to party lines service is subject to state tariffs.

### Changes in Attestation Procedure for Plugs and Jacks:

(Name of applicant) attests that the network interface plugs or jacks used on this equipment comply with and will continue to comply with the mechanical requirements specified in Part 68, Sub-part F, specifically the dimensions, tolerances and metallic plating requirements. The compliance of these connectors will be assured by purchase specifications and incoming inspection. Documentation of such specifications and/or inspections will be provided by the FCC within 30 days of their request for the same.

Table 5. CH2100 "AT" Command Set Summary

Basic Commands	Function
AT	Attention Code
A	Answer command
A'	Repeat Last Command
Bn	Communications Standard Option
D	Dial Command
E	Off-Line Character Echo Option
Hn	Switch Hook Control Option
On	On-Line Command
P	Pulse Dial
Qn	Result Code Display Option
Sn	Select an S Register
Sn=	Write to an S Register
Sn?	Read an S Register
Vn	Result Code Form Option
Xn	Result Code Set/Call Progress Option
+++	Escape Code Sequence
,	Pause
?	Returns Last Addressed S Register
Yn	Long Space Disconnect Option
Fn	On Line Echo character Option
Z	Reset

Dial Modifiers	Function
P	Pulse Dial
R	Originate Call in Answer Mode
T	Touch Tone Dial
W	Wait for Dial Tone
;	Return to Idle State
@	Wait for Quiet Answer Command
!	Flash Hook
,	Pause
0-9	Dial Digits/Characters
A,B,C,D	

  

Ampersand Commands	Function
&F	Load Factory Defaults
&Gn	Guard Tone Option
&Pn	Make to Break Ratio Selection
&Tn	Test Command Option
&V	View Active Configuration

Percent Commands	Function
%Dn	DTMF Attenuation
%J	Load Secondary Factory Defaults

**NOTE: A detailed definition of all commands and registers is available from Cermetek Microelectronics, Inc. Refer to Cermetek Document "AT Commands and S-Registers Reference Guide." Web Site: [www.cermetek.com](http://www.cermetek.com).**

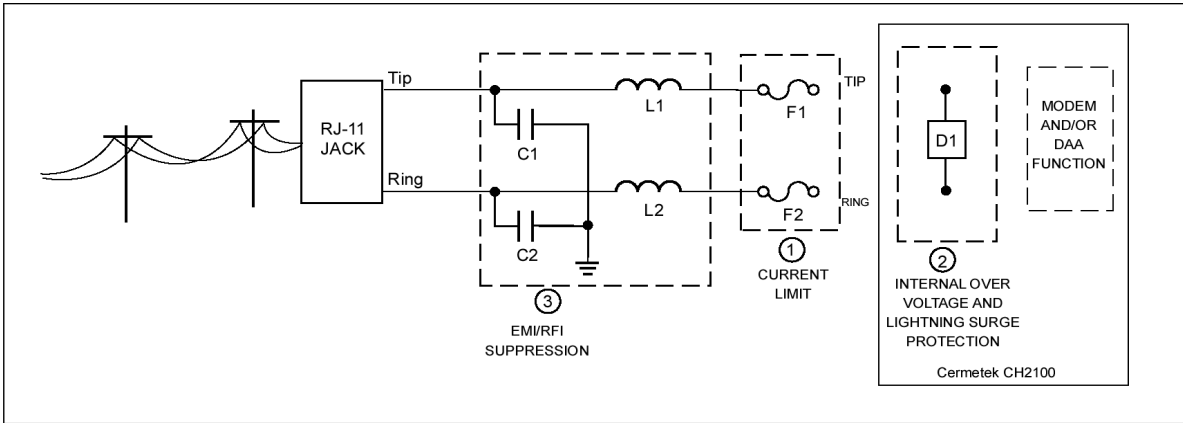

1. **Current Limiting PSTN Protection Line Device.**  
 Current limiting devices are mandatory to meet UL safety standards. To maintain conveyed FCC Part 68 approval, the current limiting components identified as F1 and F2 must also survive FCC Part 68 surge testing. Refer to Cermetek Application Note #126 for more details.
  - A. A Raychem Polyfuse TR 600-150 (rated at 0.15 amps) is preferred because this device resets automatically upon removal of the current flow and passes the FCC part 68 surge tests. Non-resetable devices such as Littlefuse, type 220003, or WICKMANN 19397-038 are also acceptable.
  - B. Resistors (10Ω carbon film or 1/8 watt minimum) may be used in Canada as Canada has no requirement that PSTN equipment be operational after a Type B surge test.
  - C. Although CSA CS-03 Part 1 (Canada) follows the requirements of FCC Part 68 (USA), Cermetek recommends contacting DOT (Canada) and/or a certified independent lab to verify compliance. For Canada, use either 10Ω resistors (carbon film or SMD parts 1/8 watt minimum) as described in paragraph B above, or non-resetable fuses or resetable Polyfuses as described in paragraph A above.
2. **Over Voltage and Lightning Surge Protection.**  
 Over voltage and lightning surge protection is mandatory for FCC Part 68 compliance. It can be seen that Cermetek provides the required surge protection (identified as D1 in dashed box #2) within the CH2100 product. No additional surge protection is necessary to preserve the conveyed FCC Part 68 approval. Refer to Cermetek Application Note #126 for more details.
3. **EMI/RFI Suppression.**  
 Cermetek has designed its products to minimize EMI/RFI noise generation. External EMI/RFI suppression circuitry is not required to maintain FCC Part 68 conveyed approval but may be required to meet other FCC requirements.
  - A. To provide adequate EMI/RFI suppression, the capacitor/inductor network contained in dashed box #3 should be located as close to the RJ11 Jack as possible. Further, this network should be provided with an excellent ground path to the chassis.
  - B. Capacitors C1 and C2 should not exceed 0.005 μf. They must have a rating of 1.5 KV and typically are .001 μf +/- 20%. Recommended devices for inductors L1 and L2 are Fair-Rite 2643666611 or 294366661 or equivalent. For UL applications, choose capacitors and inductors that are UL 1950 listed. The actual values of the components used may vary depending on the end product design.

**Figure 3. PSTN Line Interface for CH2100 Products.**

**Telephone Company Procedures:** The goal of the telephone company is to provide you with the best service it can. In order to do this, it may occasionally be necessary for them to make changes in their equipment, operations or procedures. If these changes might affect your service or the operation of your equipment, the telephone company will give you notice, in writing, to allow you to make any changes necessary to maintain uninterrupted service. In certain circumstances, it may be necessary for the telephone company to request information from you concerning the equipment which you have connected to your telephone line. Upon request of the telephone company, provide the FCC registration number and the ringer equivalence number (REN); both of these items are listed on the equipment label. The sum of all of the REN's on your telephone lines should be less than five in order to assure proper service from the telephone company. In some cases, a sum of five may not be useable on a given line. Consult your telephone provider.

**If Problems Arise:** If any of your telephone equipment is not operating properly, you should immediately remove it from your telephone line, as it may cause harm to the telephone network. If the telephone company notes a problem, they may temporarily discontinue service. When practical, they will notify you in advance of this disconnection. If advance notice is not feasible, you will be notified as soon as possible. When you are notified, you will be given the opportunity to correct the problem and informed of your right to file a complaint with the FCC. Contact your local telephone service provider if you have any questions about your phone line.

In the event repairs are ever needed on the (insert your product name), they should be performed by (insert your company name) or an authorized representative of (insert your company name). For information contact: (insert your company address).

**The following is a summary of the Default Configuration Profile installed by Cermetek Microelectronics, Inc., prior to delivery of the CH2100.**

- Async mode selected
- 2400bps
- Bell 212A operation at 1200bps
- Even parity
- Auto answer disabled
- Command echo ON
- All result codes enabled – extended
- Wait for dial tone before dialing = 2 seconds
- Detects busy signal
- Full word result codes
- Pulse dial make/break ratio = 39/61
- DSR enabled
- Guard tones disabled
- Escape code character = 43
- Carriage return character = 13
- Line feed character = 10
- Back space character = 8
- Duration of wait for dial tone = 2 seconds
- Duration of wait for carrier after dialing = 30 seconds
- Duration of dial pulse (comma) = 2 seconds
- Carrier detect response time = 0.1 seconds
- Escape code guard time = 1 second
- Length of use after comma = 2.0 seconds
- Last carrier to hang up delay = 0.1 seconds
- DTMF interdigit delay = 0.1 seconds
- DTMF Attenuation = -4dB
- Sleep mode inactivity time = 5 seconds
- Long space disconnect disabled

**Table 6. CH2100 System Data Mode Compatibility Specifications**

Parameter	Specification	Parameter	Specification
Asynchronous	2400, 1200, 600 bps character asynchronous. 0-300 bps asynchronous	Receive Carrier Frequencies V.22 bis, V.22, 212A	Originate 2400Hz + 7Hz Answer 1200Hz ± 7Hz
Asynchronous Speed Range	TxD may differ +1%, -2.5% from modem output. Offsets will be corrected by adding/deleting stop bits.	Bell 103	Answer 'space' 2020Hz + 7Hz Answer 'mark' 2225Hz ± 7Hz Original 'space' 1070Hz + 7Hz Original 'mark' 1270Hz ± 7Hz
Telephone Line Interface	Two-wire full duplex over public switched network. On-chip hybrid and billing delay timers.	Billing Delay	2.0 to 3.0 seconds (T <sub>a</sub> =25°C)
Modulation	V.22 bis, 16 point QAM at 600 baud. V.22 and 2212A, 4 point, DPSK at 600 baud. 103 binary phase coherent FSK.	Hysteresis	2 dB minimum
Self Test Pattern Generator	Alternate 'ones' and 'zeros' and error detector, to be used along with most loopbacks. A number indicating the bit errors detected is sent to DTE.	Line Equalization	Fixed compromise equalization, transmit. Adaptive equalizer for PSK/QAM, receive.
Transmit Carrier Frequencies V.22 bis, V.22, 212A	Originate 1200Hz±.01% Answer 2400Hz±.01%	Diagnostics Available	Local analog loopback. Local digital loopback. Remote digital loopback. Request remote digital loopback. Local interface loopback modem with self test.
Bell 103 mode	Originate 'space' 1070Hz ±.01% Originate 'mark' 1270Hz ±.01% Answer 'space' 2020Hz ±.01% Answer 'mark' 2225Hz ±.01%	Call Progress Tones Detected  Computer Interface	With speaker or quiet screen messages (no dial tone, busy, ring-back, modem answer tone and voice).  IBM PC/XT/AT bus compatible with an 8250/16450/16550A UART as a serial controller.

**Table 7. CH2100 Electrical Specifications**  
T<sub>a</sub>=25°C

Symbol	Characteristic	Min.	Typ.	Max.	Units
V <sub>cc</sub>	Supply voltage	4.75	5.0	5.25	V
I <sub>cc</sub>	Supply Current Off hook operating current On hook operating current Power down operating current		40 32 7		mA mA mA
V <sub>OL</sub>	Output Low Voltage (I <sub>OL</sub> =20mA) RI (I <sub>OL</sub> =2.0mA) RI. RXD (I <sub>OL</sub> =1.6mA)		0.1	0.10 0.26 0.40	V V V
V <sub>OH</sub>	Output High Voltage (I <sub>OH</sub> =-20mA) RI (I <sub>OH</sub> =-2.0mA) RI RXD (I <sub>OL</sub> =-100mA)	4.40 4.18 2.40	4.50 4.37		V V V
V <sub>IL</sub>	Input Low Voltage RST TXD	-0.30 -0.30		0.80 0.80	V V
V <sub>IH</sub>	Input High Voltage RST TXD	3.5 2.0			V V
I <sub>IN</sub>	Input Leakage Current RST, TXD, RXD			100.0	uA
C <sub>P</sub>	Capacitive Load RST, TXD, RXD			10.0	pF



**Table 8. CH2100 Electrical Specifications**

Parameter	Minimum	Typical	Maximum	Units	Comments
Ring Voltage Sensitivity	40			VRMS	
Return Loss @ 1000 Hz		17		dB	600 ohm
Ring Frequencies	15.3		68	Hz	
Transmit Level		-12		dBm	600 ohm - Data Mode
Command Mode After Reset	200			msec	Delay
Inter Character Delay	20			msec	Between all command characters
Command Delay	100			msec	Between all AT commands
Minimum Reset Pulse	10			msec	If user supplied

**Table 9. Other Performance Specifications**

Parameter	Minimum	Typical	Maximum	Units	Comments
DTMF Twist (Balance)		3		dB	
DTMF Tone Duration	50		255	ms	95 ms default
Pulse Dialing Rate		10	20	pps	10pps default
Pulse Dialing Make/Break		39/61		%	US, Canada default
Pulse Dialing Make/Break		33/67		%	UK, Hong Kong
Pulse Interdigit Interval	700		3000	ms	789 ms default
Call Progress Passband Frequency	120		620	Hz	
Wait Time for Dial Tone	2		255	sec	Two seconds default

**Table 10. Summary of CH2100 Product Family Options**

Model	Summary of Features	Operating Temperature
CH2100	Full Function, FCC Part 68 Approved, Hermetic	0°C to 70°C
CH2100ET	Full Function + Extended Temperature Performance, FCC Part 68 Approved, Hermetic	-40°C to 85°C

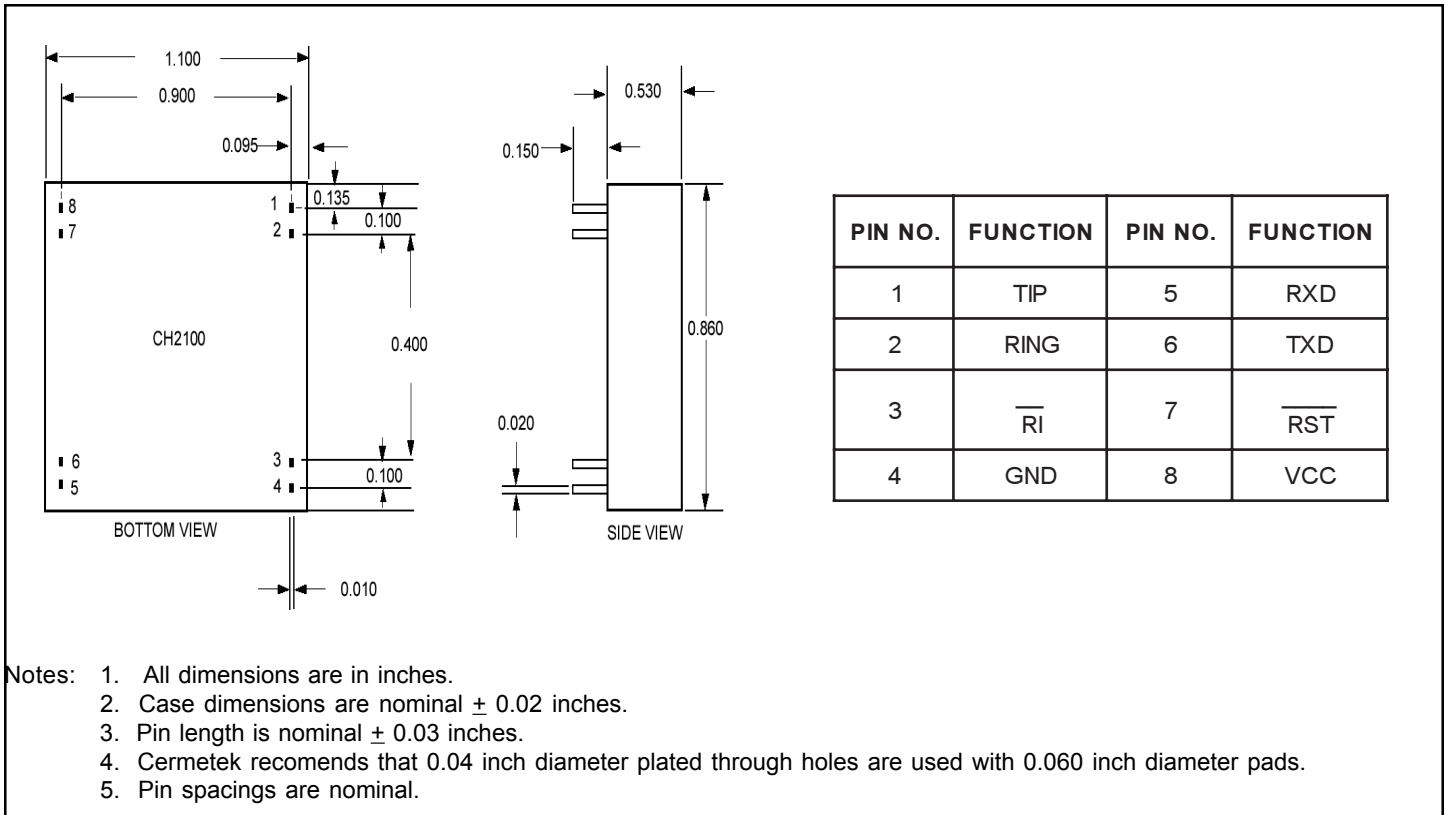

**Figure 4. CH2100 Physical Dimensions and Pin Functions.**

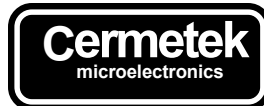

406 TASMAN DRIVE · SUNNYVALE, CALIFORNIA 94089 · TEL: (408) 752-5000 FAX: (408) 752-5004

E-mail: [cermstaf@cermetek.com](mailto:cermstaf@cermetek.com)

website: [www.cermetek.com](http://www.cermetek.com)

Cermetek reserves the right to make changes in specifications at any time and without notice. The information furnished by Cermetek in this publication is believed to be accurate and reliable. However, no responsibility is assumed by Cermetek for its use, or for any infringements of patents or other rights of third parties resulting from its use. No license is granted under any patents or patent rights of Cermetek.

Printed in U.S.A.