

Service Manual

Personal Computer

CF-T4

This is the Service Manual for
the following areas.
M ...for U.S.A. and Canada

Datasheet.Live

Model No. CF-T4GWCTZ1 2

1: Operation System

B: Microsoft® Windows® XP Professional

2: Area

M: Refer to above area table

WARNING

This service information is designed for experienced repair technicians only and is not designed for use by the general public. It does not contain warnings or cautions to advise non-technical individuals of potential dangers in attempting to service a product. Products powered by electricity should be serviced or repaired only by experienced professional technicians. Any attempt to service or repair the product or products dealt with in this service information by anyone else could result in serious injury or death.

Panasonic®

© 2005 Matsushita Electric Industrial Co., Ltd. All rights reserved.
Unauthorized copying and distribution is a violation of law.

WARNINGS

For U.K.

This apparatus must be earthed for your safety.

To ensure safe operation the three-pin plug must be inserted only into a standard three-pin power point which is effectively earthed through the normal household wiring.

Extension cords used with the equipment must be three-core and be correctly wired to provide connection to earth. Wrongly wired extension cords are a major cause of fatalities.

The fact that the equipment operates satisfactorily does not imply that the power point is earthed and that the installation is completely safe.

For your safety, if you have any doubt about the effective earthing of the power point, consult a qualified electrician.

FOR YOUR SAFETY PLEASE READ THE FOLLOWING TEXT CAREFULLY

This appliance is supplied with a moulded three pin mains plug for your safety and convenience.

A 3 amp fuse is fitted in this plug.

Should the fuse need to be replaced please ensure that the replacement fuse has a rating of 3 amps and that it is approved by ASTA or BSI to BS 1362.

Check for the ASTA mark  or the BSI mark  on the body of the fuse.

If the plug contains a removable fuse cover you must ensure that it is refitted when the fuse is replaced.

If you lose the fuse cover the plug must not be used until a replacement cover is obtained.

A replacement fuse cover can be purchased from your local Panasonic Dealer.

IF THE FITTED MOULDED PLUG IS UNSUITABLE FOR THE SOCKET OUTLET IN YOUR HOME THEN THE FUSE SHOULD BE REMOVED AND THE PLUG CUT OFF AND DISPOSED OF SAFELY.

THERE IS A DANGER OF SEVERE ELECTRICAL SHOCK IF THE CUT OFF PLUG IS INSERTED INTO ANY 13 AMP SOCKET.

If a new plug is to be fitted please observe the wiring code as shown below.

If in any doubt please consult a qualified electrician.

Warning: THIS APPLIANCE MUST BE EARTHED.

Important

The wires in this mains lead are coloured in accordance with the following code:

Green-and-yellow:	Earth
Blue:	Neutral
Brown:	Live

As the colours of the wires in the mains lead of this apparatus may not correspond with the coloured markings identifying the terminals in your plug, proceed as follows:

The wire which is coloured GREEN-and-YELLOW must be connected to the terminal in the plug which is marked by the letter E or by the safety earth symbol  coloured GREEN or GREEN-and-YELLOW.

The wire which is coloured Blue must be connected to the terminal which is marked with the letter N or coloured BLACK.

The wire which is coloured Brown must be connected to the terminal which is marked with the letter L or coloured RED.

The mains plug on this equipment must be used to disconnect the mains power.

Please ensure that a socket outlet is available near the equipment and shall be easily accessible.

How to replace the fuse

Open the fuse compartment with a screw-driver and replace the fuse.

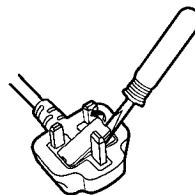

Warnings

- This equipment is not designed for connection to an IT power system.
(An IT system is a system having no direct connections between live parts and Earth; the exposed-conductive-parts of the electrical installation are earthed.
An IT system is not permitted where the computer is directly connected to public supply systems in the U.K.)
- Disconnect the mains plug from the supply socket when the computer is not in use.

This equipment is produced to BS800/1983.

1 Read Me First

Safety precautions

1. Before servicing, unplug the power cord to prevent an electric shock.
2. When replacing parts, use only manufacture's recommended components for safety.
3. Check the condition of the power cord. Replace if wear or damage is evident.
4. After servicing, be sure to restore the lead dress, insulation barriers, insulation papers, shields, etc.

Lithium Battery

Lithium Battery!

This computer contains a lithium battery to enable the date, time, and other data to be stored. The battery should only be exchanged by authorized service personnel.

Warning! A risk of explosion from incorrect installation or mis-application may possibly occur.

LITHIUM BATTERY ⚠

• CAUTION

Danger of explosion if battery is incorrectly replaced.

Replace only with the same or equivalent type recommended by the equipment manufacture.

Discard used batteries according to the manufacturer's instructions.

Precautions

● Usage

Avoid Extreme Heat and Cold

Do not store or use the computer in locations exposed to heat, direct sunlight, or extreme cold.

Avoid moving the computer between locations with large temperature difference.

Operation: 5 °C to 35 °C {41 °F to 95 °F}

Storage: -20 °C to 60 °C {-4 °F to 140 °F}



Avoid Direct Sunlight on the LCD Panel

The LCD panel should not be exposed to direct sunlight or ultraviolet light.



Avoid Humidity, Liquids and Dust

Do not store or use the computer in locations exposed to high humidity, liquids (including rain) or dust.



Prevent Shock

Avoid subjecting the computer to severe vibrations or impact. Do not place the computer inside a car trunk.

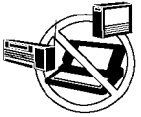

Avoid Radio Frequency Interference

Do not place the computer near a television or radio receiver.



Avoiding low-temperature burns

Avoid more than casual contact with any heat producing area of the notebook computer, AC adaptor, and any option or accessory you use with it. Even low heat, if warmer than body temperature, can cause a burn, if the skin is exposed to the heat source for a long enough period of time.

● Handling



Avoid Magnetic Fields

Keep the computer away from magnets. Data stored on the hard disk may be lost.



Avoid Stacking

Do not place heavy objects on top of the computer.



Keep Small Objects Away

Do not insert paper clips or other small objects into the computer.



Do Not Disassemble the Computer

Do not attempt to disassemble your computer.



Avoid Excessive Force on the Display

Do not apply excessive downward force on the display.

● Cables

Use of an interface cable longer than 3 m (9.84 feet) is not recommended.

Precautions (Battery Pack)

- Care should be exercised with regard to the following in order to avoid the possibility of overheating, fire or damage.



Avoid Heat

Do not throw the battery pack into a fire or expose it to excessive heat.



Keep Articles Away

Do not place the battery pack together with articles such as necklaces or hairpins when carrying or storing.



Do Not Disassemble

Do not insert sharp objects into the battery pack, expose it to bumps or shocks, deform, disassemble, or modify it.



Do Not Short

Do not short the positive (+) and negative (-) contacts.



Avoid Extreme Heat, Cold and Direct Sunlight

Do not charge, use or leave the battery pack for extended periods where it will be exposed to direct sunlight, in a hot place (in a car on a sunny day, for example), or in a cold place.



Do Not Use With Any Other Computer

The battery pack is rechargeable and was intended for the specified computer. Do not use it with a computer other than the one for which it was designed.



Do Not Put into a Microwave

Do not put the battery pack into a microwave oven or a pressurized chamber.



Stop Using

Should the battery emit an abnormal odor, become hot to the touch, become discolored, change shape, or become in any way different from normal, remove it from the computer and stop using it.

- Do not touch the terminals on the battery pack. The battery pack may no longer function properly if the contacts are dirty or damaged.
- Do not expose the battery pack to water, or allow it to become wet.

- If the battery pack will not be used for a long period of time (a month or more), charge or discharge (use) the battery pack until the remaining battery level becomes 30% to 40% and store it in a cool, dry place.
- This computer prevents overcharging of the battery by recharging only when the remaining power is less than approx. 95% of capacity.
- The battery pack is not charged when the computer is first purchased. Be sure to charge it before using it for the first time. When the AC adaptor is connected to the computer, charging begins automatically.
- Should the battery leak and the fluid get into your eyes, do not rub your eyes. Immediately flush your eyes with clear water and see a doctor for medical treatment as soon as possible.

NOTE

- The battery pack may become warm during recharging or normal use. This is completely normal.
- Recharging will not commence outside of the allowable temperature range (0 °C to 55 °C {32°F to 131 °F}). (☞ Reference Manual “Battery Power”) Once the allowable range requirement is satisfied, charging begins automatically. Note that the recharging time varies based on the usage conditions. (Recharging takes longer than usual when the temperature is 10 °C {50 °F} or less.)
- If the temperature is low, the operating time is shortened. Only use the computer within the allowable temperature range.
- The battery pack is a consumable item. If the amount of time the computer can be run off a particular battery pack becomes dramatically shorter and repeated rechargings do not restore its performance, the battery pack should be replaced with a new one.
- When transporting a spare battery inside a package, briefcase, etc., it is recommended that it be placed in a plastic bag so that its contacts are protected.
- Always power off the computer when it is not in use. Leaving the computer on when the AC adaptor is not connected will exhaust the remaining battery capacity.

Saving Data on the Hard Disk

- **Do not expose your computer to shock.**
Use care when handling your computer, shock may damage your hard disk or make your software applications and data unusable.
- **Do not power off your computer while software applications are running or hard disk drive indicator (LED) is on.**
Properly shut Windows* down to avoid problems.
- **Save all valuable data to disks.**
Backing up data to disks will limit damage should trouble occur to your computer or should you inadvertently change or erase data.
- **Use the security function for all important data.**

* This computer uses Microsoft® Windows® XP Professional.

Computer Viruses

Users are advised to purchase the latest versions of virus protection software and use them regularly.

We recommend you run the software:

- After booting your Computer.
- After receiving data.

We recommend that you check data received on disks or from external sources, such as data downloaded from the Internet, e-mail, etc. (For compressed files, uncompress them before running a check).

When Using Peripheral Devices

Pay strict attention to the following points to avoid damage to the computer, peripheral devices, cables, etc. Also, in addition to following the manual and the Reference Manual, carefully read the instruction manuals for the peripheral devices being used.

- Use only peripheral devices that conform to the computer's specifications.
- Connect the devices properly, paying close attention to the condition and position of the connectors.
- If a connection cannot be made easily, do not apply undue force; check once more to confirm the condition and position of the connector (alignment of pins, etc.).
- If the connector has holding screws, fasten the screws firmly.
- Do not carry the computer with cables attached, and do not pull on the cables forcefully.

When Disposing of or Transferring Ownership of This Device

When disposing of or transferring ownership of this device, erase all data on the hard disk in order to prevent the theft of hard disk data. Even if you delete data or initialize the hard disk through normal Windows commands, data can still be read using special software. In order to erase all data, either have the data erased by a specialist (at a charge) or use the hard disk data erase utility (included). (Note that this hard disk data erase utility does not guarantee that data will be completely erased.)

Also note that if you transfer ownership of this device without deleting commercial software that you have installed to the hard disk, you may be in violation of licensing agreement for that software.

Usage Environment

● Environment

- Place the computer on a flat stable surface. Do not place the computer upright or allow it to tip over.
When the computer receives extremely strong shock after falling, the hard disk may become inoperable.

- In use: Temperature: 5 °C to 35 °C {41 °F to 95 °F}
 Humidity: 30% to 80% RH (No condensation)
- Not in use: Temperature: -20 °C to 60 °C {-4 °F to 140 °F}
 Humidity: 30% to 90% RH (No condensation)

● Places not to use your computer

- Such areas may result in damage to the computer.

Areas with electronic equipment

These areas may interfere with your display or cause your computer to produce strange sounds.

Areas with extremely high/low temperatures

- Do not leave things near the computer that are sensitive to heat. During operation, the computer may become warm.



Handling

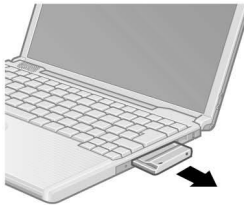

- This computer has been designed so as to minimize shock to the LCD and hard disk drive, etc., but no warranty is provided against such trouble. Therefore, as a precision instrument, be extremely careful in the handling.
- Do not carry the computer while the display is open, or carry it by gripping the display or the cabinet around the display (see figure upper left). When closing the display, ensure that the latch is positioned correctly in the slot.
- Do not drop or hit your computer against solid objects.
- Do not carry your computer when it is on.
- Remove all external devices, cables, PC Cards sticking out of the computer (see the figure lower left), SD memory cards, and MultiMedia Cards before transporting the computer.
- We recommend preparing a fully charged battery.
When transporting a spare battery inside a package, briefcase, etc., it is recommended that it be placed in a plastic bag so that its contacts are protected.
- Always carry your computer with you. Never check it in with luggage. For use of the computer inside an aircraft, we recommend asking the airlines regarding their policy on this issue.
- It is a good idea to make backup copies on disks and carry them with you.

Maintenance

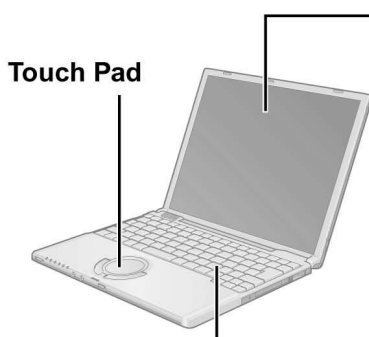

Display

Avoid using water when cleaning the panel. Ingredients included in water may leave scratches and reduce readability of the screen.

<When cleaning dust/dirt>

Avoid rubbing off dust/dirt with cloth since it may leave scratch on the screen.

Sweep dust/dirt with fine brush, then wipe it with a dry soft cloth used for cleaning glasses.

<When cleaning oily surface>

Apply camera lens cleaner on a soft gauze and clean it with gentle force. Then, wipe with a dry soft cloth used for cleaning glasses.

Areas excluding the display

Wipe these areas with a soft cloth, after applying water or detergent diluted with water to the soft cloth and firmly wringing out excess water.

CAUTION

- Do not use benzene, thinner, or rubbing alcohol. Doing so may adversely affect the surface, e.g., discoloration. In addition, do not use commercially-available household cleaners and cosmetics, as they may contain components harmful to the surface.
- Do not directly add or spray water or detergent. If liquid enters the inside of the computer, it may cause it to work improperly or be damaged.

1 Connection Diagram

- Connection by Cable
- - - Direct connection Connectors
- ⋯ Parts on Bottom Side

Connection Cable		
※1	LCD Cable	DFJS963ZA
※2	Speaker Cable	DFJS962ZA
※3	Antenna PCB-L	N1ZYYY000002
※4	Antenna PCB-R	N1ZYYY000003
※5	Modem Cable	DFJS973ZA
※6	LAN Cable	DFJS958ZB
※7	PAD FFC	DFJE12U112BB
※8	HDD FPC Unit	DL3UP1443AAA
※9	DC-IN Cable	DFJS961ZB
※10	Main-Sub Cable	DFJS980ZA

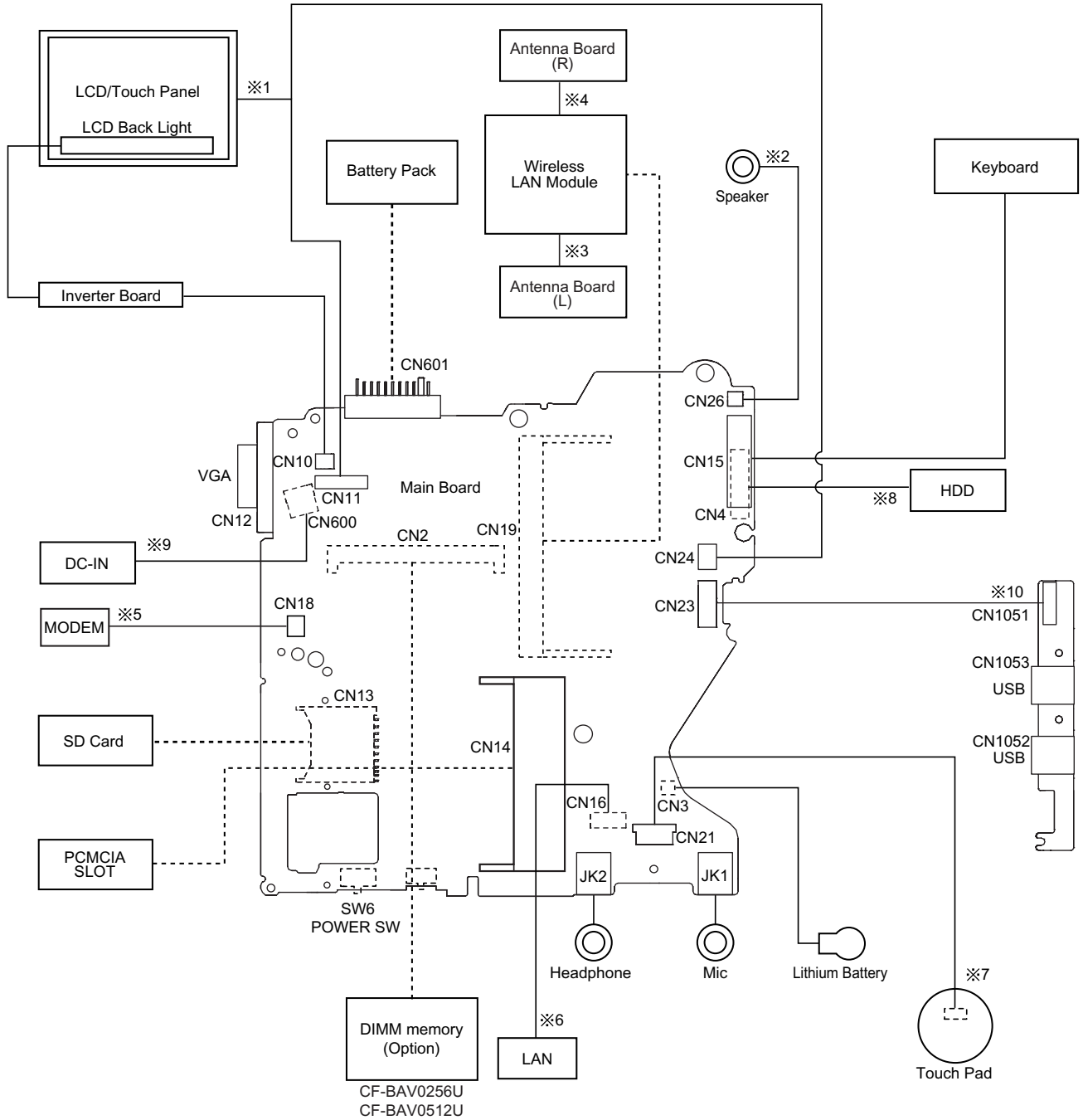

2 Disassembly instructions

2.1. Disassembly Flow Chart

● Main Unit

2.2.1.

Preparation

1. End the Windows.
2. Turn off the power, and then remove the AC adaptor or battery pack.
3. Remove any optional DIMM memory cards or PCMCIA cards.
4. Remove any other peripherals or connected devices.

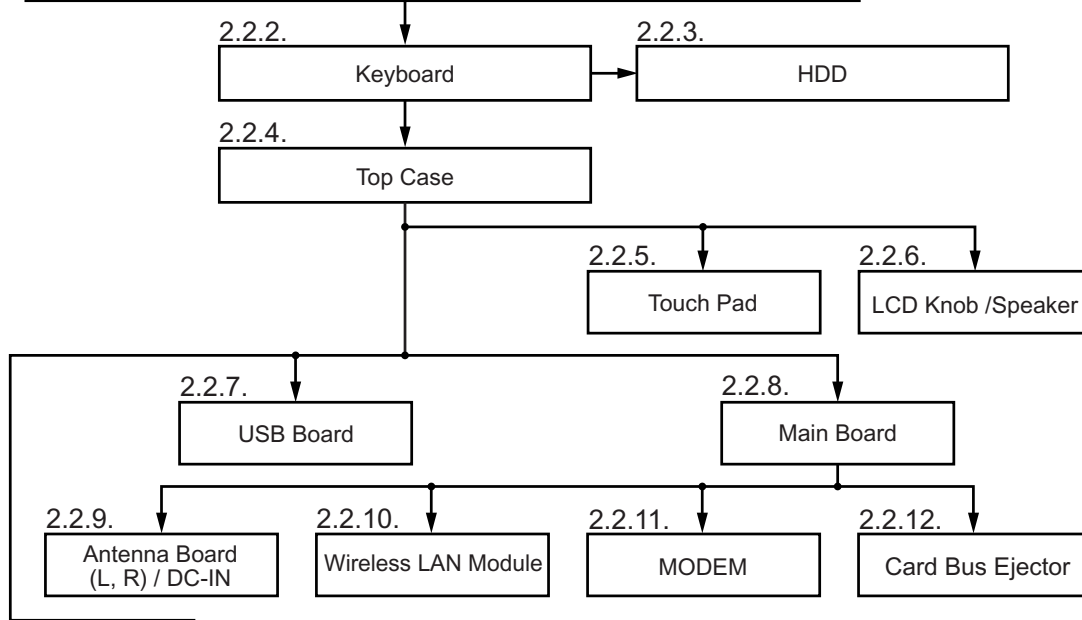

● Display Unit

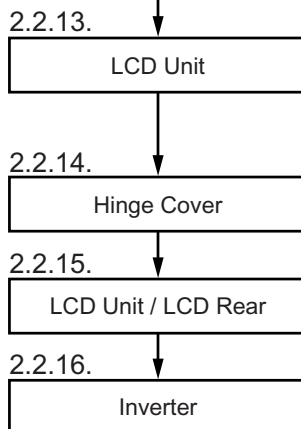

Main replaceable parts

- | | |
|--|--|
| <p>2.2.1. ▪ Battery Pack
▪ DIMM Cover
▪ AC Adaptor</p> <p>2.2.2. ▪ Keyboard</p> <p>2.2.3. ▪ HDD
▪ HDD Case</p> <p>2.2.4. ▪ Top Case
▪ Side Cover (R)</p> <p>2.2.5. ▪ Touch Pad
▪ Pad Cover
▪ PAD Button
▪ PAD FPC</p> <p>2.2.6. ▪ LCD Knob
▪ Speaker</p> <p>2.2.7. ▪ USB Board
▪ USB Cable</p> | <p>2.2.8. ▪ Main Board</p> <p>2.2.9. ▪ Antenna Board (L, R)
▪ DC-IN Cable</p> <p>2.2.10. ▪ Wireless LAN Module</p> <p>2.2.11. ▪ MODEM</p> <p>2.2.12. ▪ Card Bus Ejector</p> <p>2.2.13. ▪ LCD Unit</p> <p>2.2.14. ▪ Hinge Cover
▪ Hinge (L, R)</p> <p>2.2.15. ▪ LCD Unit
▪ LCD Rear
▪ LCD Front</p> <p>2.2.16. ▪ Inverter
▪ LCD Cable</p> |
|--|--|

2.2. Disassembly

2.2.1. Preparation

Attention:

Before disassembly, be sure to perform the following steps.

1. End the Windows.
2. Turn off the power and then remove the AC adaptor.
3. Slide the hooks (A) and then remove the battery pack.
4. Remove the screw (A) and then remove the DIMM cover.
(Remove if the DIMM memory is equipped with)
Screw (A) : XSB2+4FNL(N16)

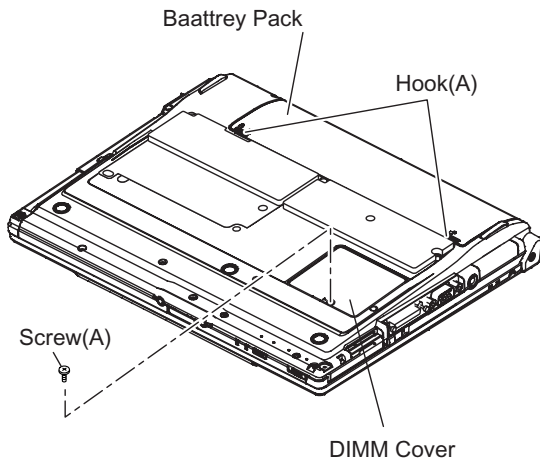

3. The LCD unit is opened up to about 90° by operating the LCD knob.
4. Remove the 6 hooks (B).
5. Open the keyboard from LCD side and then turn it inside out on the top case.

Note:

It can remove with the keyboard hook plate.

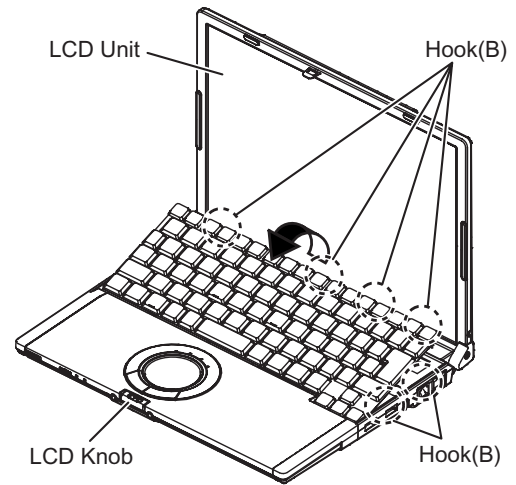

6. Remove the heat spreader from bottom of the keyboard.
7. Remove the keyboard FFC from the connector (CN15) and then remove the keyboard.

2.2.2. Removing the Keyboard

Preparation : perform the section 2.2.1. first.

1. Remove the 4 screws (B).
Screw(B):DXQT2+E12FNL(N11)
2. Remove the 2 keyboard hook plates, and then remove the hook of back side of keyboard with screw driver.

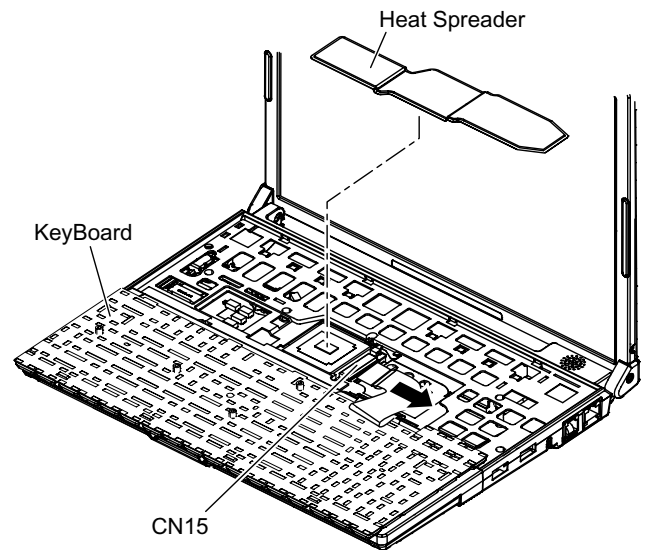
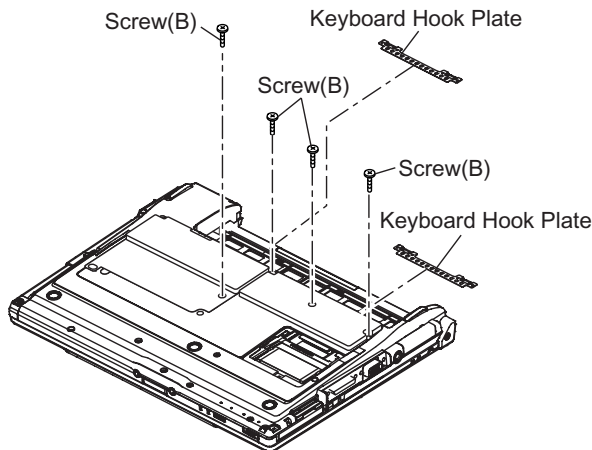

2.2.3. Removing the HDD

Preparation : perform the section 2.2.1. 2.2.2. first.

1. Remove the 2 screws (C) and then remove the HDD cover.

Screw (C):DFHE5025XA(N501)

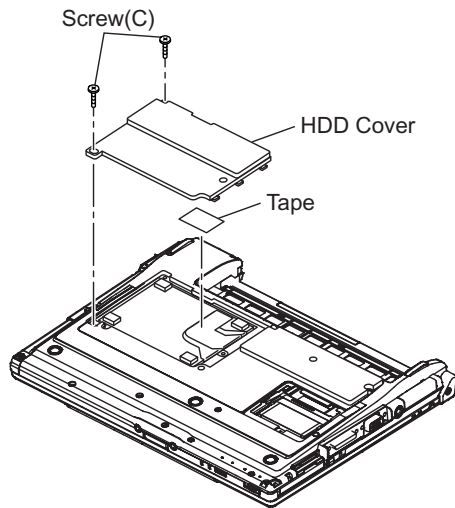

2. Lift up the HDD unit and remove FFC connector and then remove the HDD unit.

3. HDD is taken out of the HDD case.

Note:

Please do not bend pins of the HDD connector, at the time of removing HDD and FFC connector.

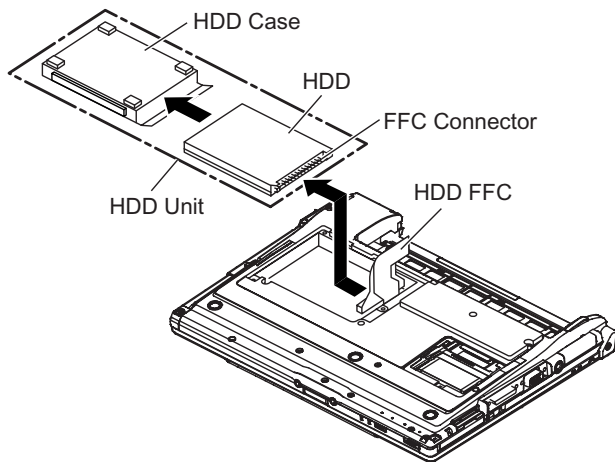

2.2.4. Removing the Top Case

Preparation : perform the section 2.2.1. , 2.2.2. first.

1. Remove the 7 screws (D) and 5 screws (G).

Screw (D):DXHM0039ZA(N5)

Screw (G):DXHM0057ZA(N7)

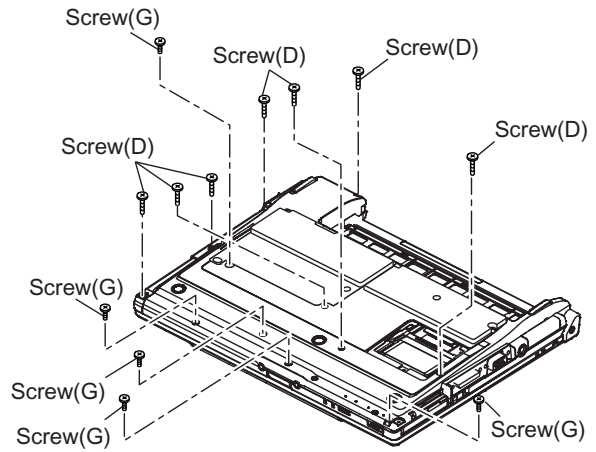

2. Remove the speaker cable from the connector (CN26).

3. Remove the side cover (R) as slide it to this side.

4. Remove the 1 screw (J), 3 screws (K) and 2 screws (L) from top case and then remove the top case.

Screw(J):DXHM0056ZA(N6)

Screw(K):DXQT2+E6FNL(N12)

Screw(L):DXQT26+D8FCL(N15)

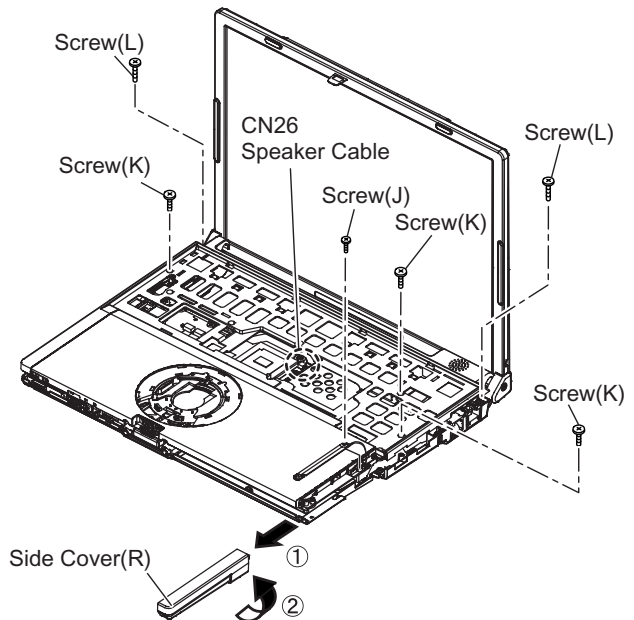

5. Lift up the top case and remove the pad FFC and then remove the top case.

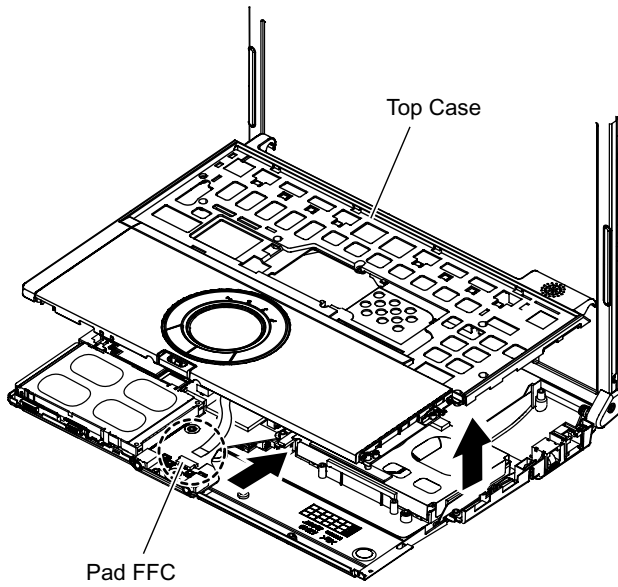

2.2.5. Removing the Touch Pad

Preparation : perform the section 2.2.1. to 2.2.3. first.

1. Peel off the tape.
2. Depress to center the 6 hooks of the pad cover, (D)(E)(F) as order.

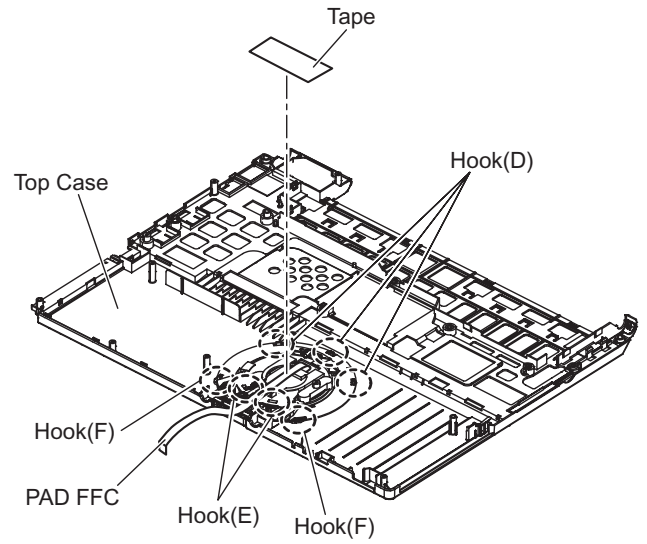

3. Remove the hook (G) and remove the touch pad.

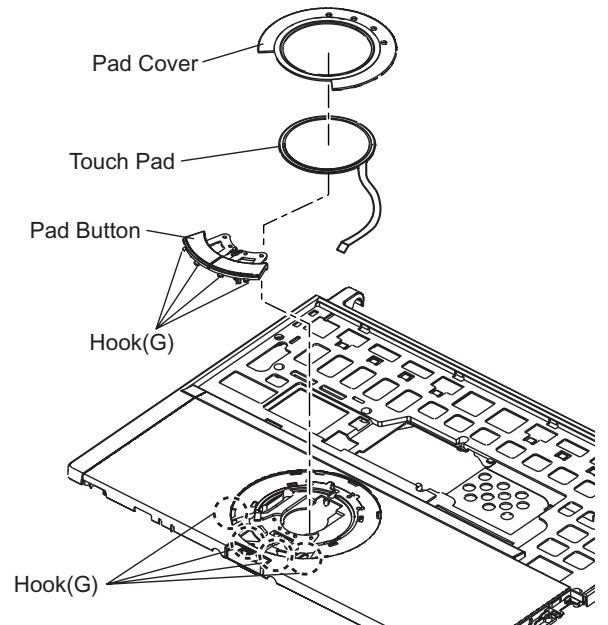

2.2.6. Removing the LCD Knob and the Speaker

Preparation : perform the section 2.2.1. to 2.2.3. first.

1. Remove the latch spring from the top case.
2. Remove the hook of the LCD knob from stopper rib of the top case.
3. Peel off the tape of the speaker box.
4. Peel off the tape on the speaker and speaker ring and then remove the speaker.

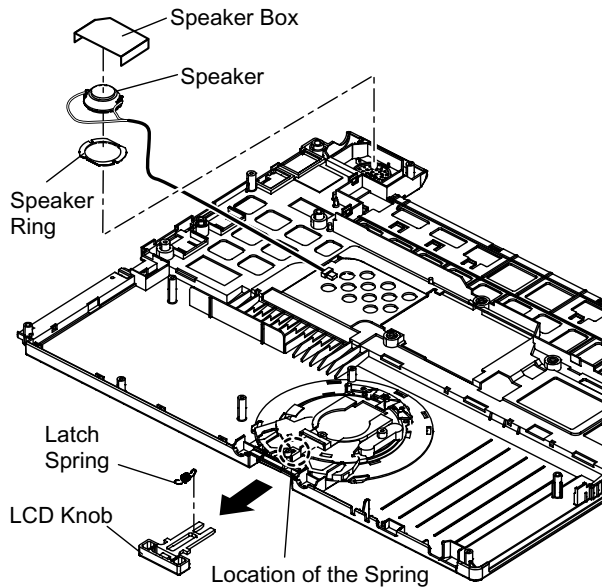

2.2.7. Removing the USB Board

Preparation : perform the section 2.2.1. to 2.2.3. first.

1. Peel off the tape for clamp the USB cable.
2. Remove the connector (CN23) on the main board.
3. Remove the USB board from the bottom case.

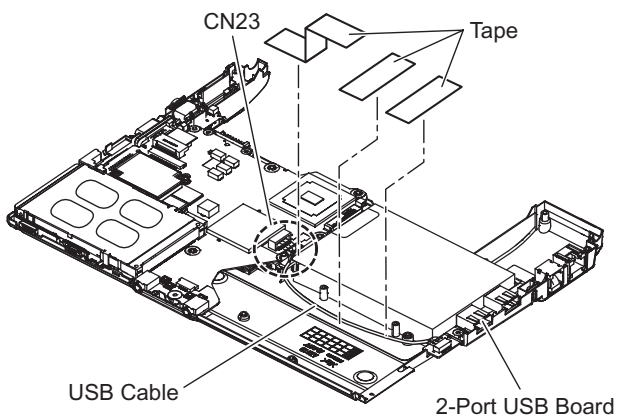

2.2.8. Removing the Main Board

Preparation : perform the section 2.2.1. to 2.2.3. first.

1. Remove the 1 screw (E), 1 screw (F) and 2 screws (H).
Screw (E):DXQT2+E10FNL(N10)
Screw (F):DXQT2+D4FNL(N9)
Screw (H):DFHE5035ZB(N2)
Screw (I):KIYE50000022(N500)

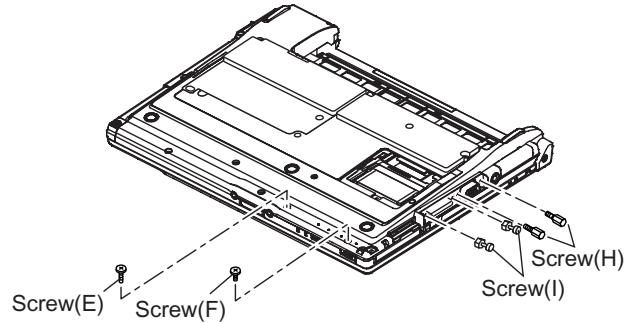

2. Remove the 2 screws (N).
Screw (N):DXQT2+E6FNL(N13)
3. Remove the modem cable from the MDC modem.
4. Remove the side cover(L) from the bottom case.

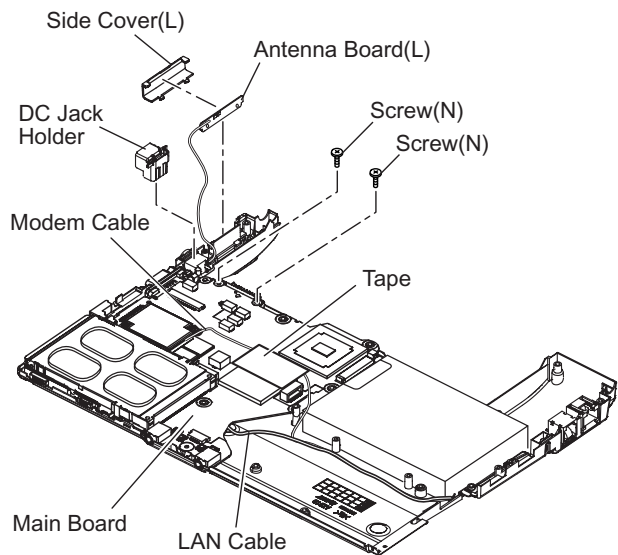

5. Remove the DC jack holder on the DC-IN jack.
6. Remove the LCD cable connectors (CN10,CN11,CN24).

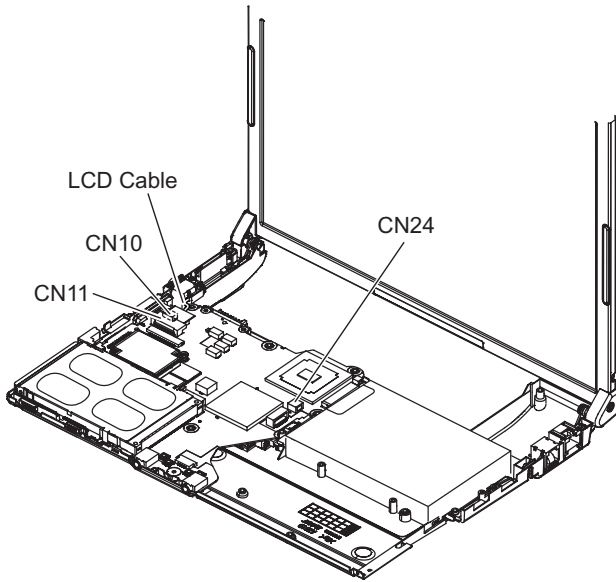

7. Turn it to arrow and remove the lithium battery connector (CN3), LAN cable connector (CN16) and HDD FPC connector (CN4) and then remove the main board.

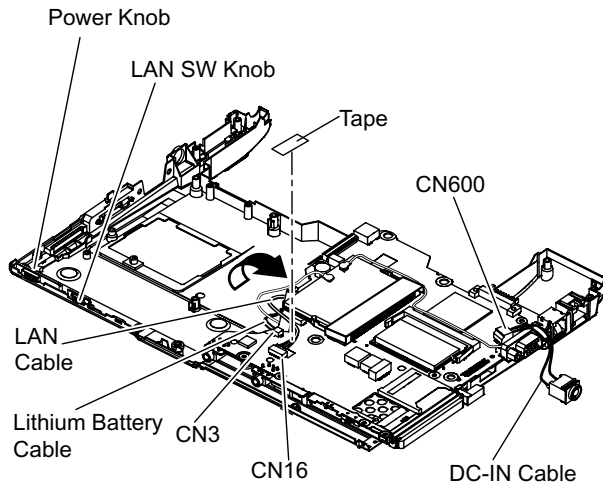

2.2.9. Removing the Antenna Board (L,R) and the DC-IN Cable

Preparation : perform the section 2.2.1. to 2.2.3. and 2.2.8. first.

1. Remove the antenna cable(L) from the main terminal and the antenna cable(R) from the AUX terminal and then remove the antenna board(L, R) from the bottom case.
2. Remove the DC-IN cable(CN600) from the main board.

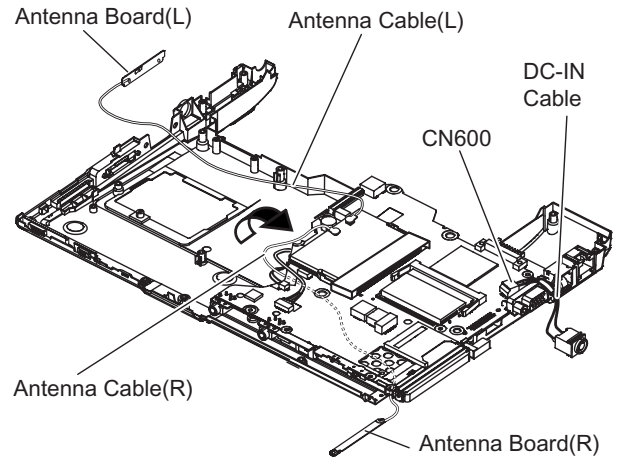

2.2.10. Removing the Wireless LAN Module

Preparation : perform the section 2.2.1. to 2.2.3. and 2.2.8. first.

1. Peel off the tape on the wireless LAN module.
2. Open the wireless LAN module holding arms and remove the wireless LAN module.

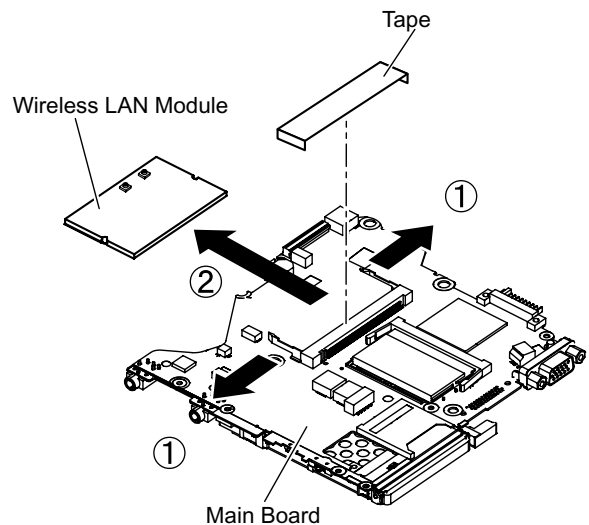

2.2.11. Removing the MODEM

Preparation : perform the section 2.2.1. to 2.2.3. and 2.2.8. first.

1. Remove the 2 screws (O).
Screw (O):DXQT2+D25FNL(N8)
2. Remove the MODEM from main board connector (CN18) as vertical.

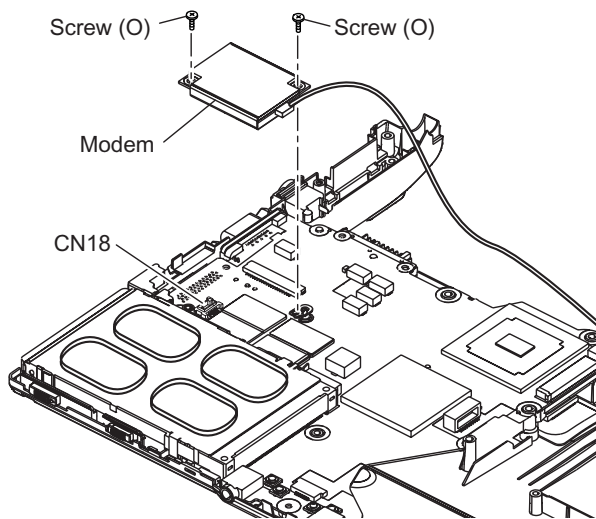

2.2.12. Removing the Card Bus Ejector

Preparation : perform the section 2.2.1. to 2.2.3. and 2.2.8. first.

1. Remove the 1 screw (P) from connection side of wireless LAN.
Screw(P):DFHE5025XA(N1)

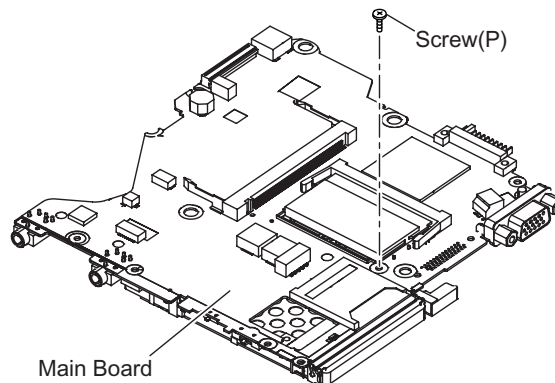

2. Turn to the card bus ejector side.
3. Remove the 2 hooks (C) from the connector (CN14).

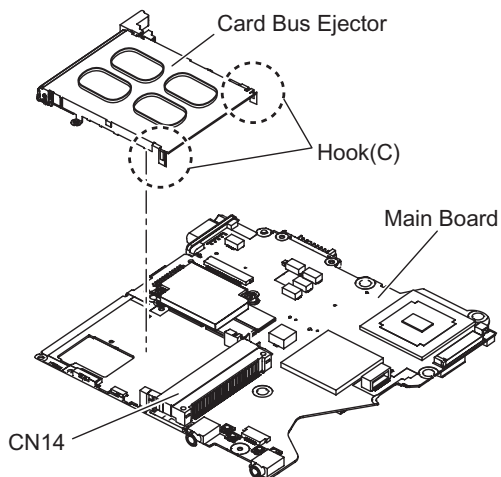

2.2.13. Removing the LCD Unit

Preparation : perform the section 2.2.1. to 2.2.3. first.

1. Remove the 2 screws (M).
Screw(M):DXQT26+D5FNL(N14)
2. Remove the LCD cable from the connector (CN11) of the main board.
3. Remove the inverter cable from the connector (CN10)
4. Remove the touch panel cable from connector (CN24).

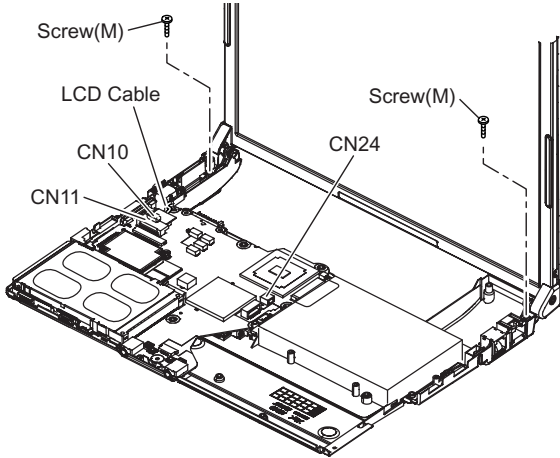

2.2.14. Removing the Hinge Cover

Preparation : perform the section 2.2.1. to 2.2.3. and 2.2.13. first.

1. Remove the 2 screws (Q) and then remove the hinge cover (L,R).
Screw(Q):DRHM0076ZA(N3)

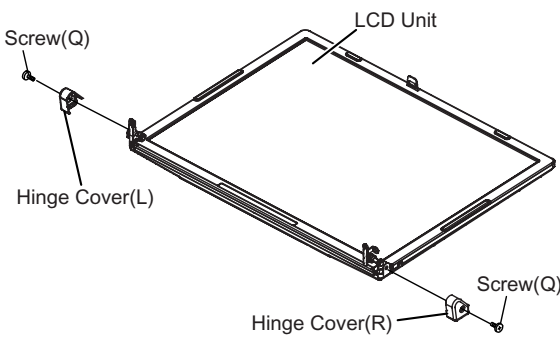

2. Remove the 2 screws (R).
Screw (R):DRHM0076ZA(N3)

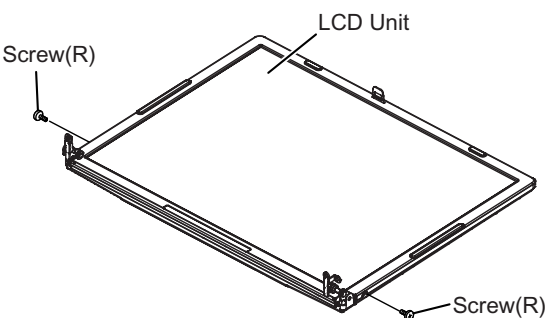

2.2.15. Removing the LCD Unit and the LCD Rear

Preparation : perform the section 2.2.1. to 2.2.3. and 2.2.13. to 2. 2. 14. first.

1. Separate the LCD front and the LCD rear.
2. Remove the hinge (L).

○ Hook Position

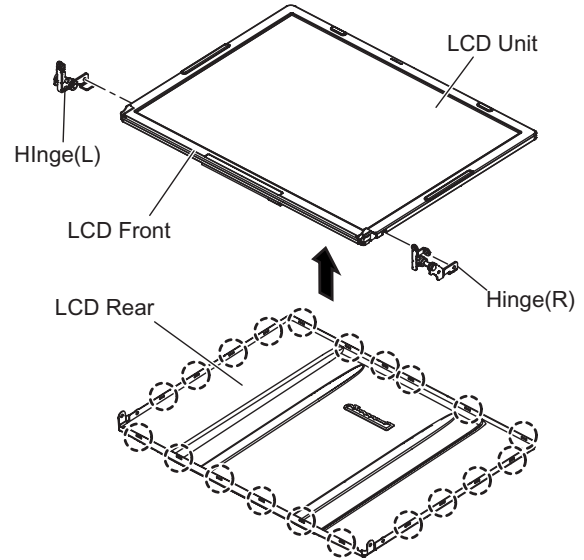

2.2.16. Remove the Inverter

Preparation : perform the section 2.2.1. to 2.2.3. and 2.2.13. to 2. 2. 15. first.

1. Remove the LCD cable from the inverter.
2. Peel off the conductive cloth(LCD cable) from the inverter.
3. Remove the inverter with inverter box.

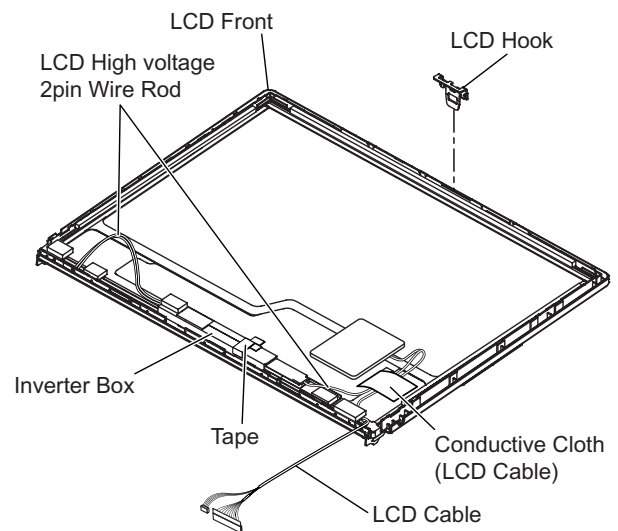

3 Reassembly instructions

3.1. Attention when CF-T4G series is repaired

- Please execute writing BIOS ID when you exchange the main board.
- Parts (sheet and rubber) etc. related various the conductive cloth and heat spreader cannot be recycled. Use new parts.

3.2. Assembly knowhow of part LCD

■ LCD rubber, LCD side rubber and LCD backing rubber's putting

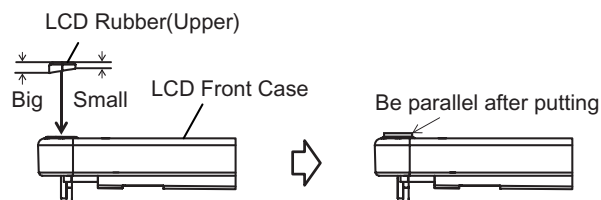
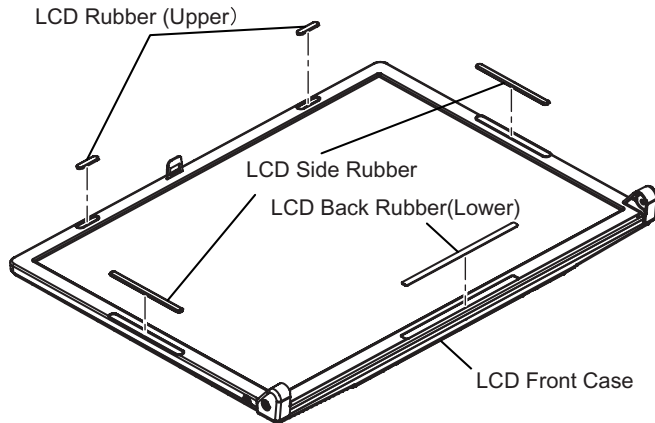

■ LCD cable processing

● Clamping processing of LCD cable, LCD connector connection and putting of PET tape of cable

- The LCD insulation sheet is peeled off.
- The LCD cable is processed to the LCD frame clamping.
- The LCD cable is connected with the connector.
- The PET tape is put.

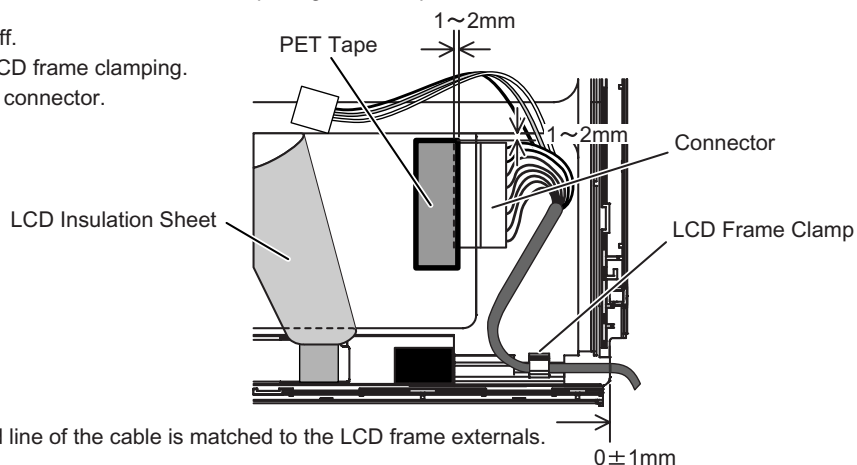

● Putting of the conductive cloth

- The conductive cloth is put and after putting a both side tape is put.
- Process the part in the Signal line of the LCD cable in the conductive cloth.
- Put the conductive cloth on the connector surely.

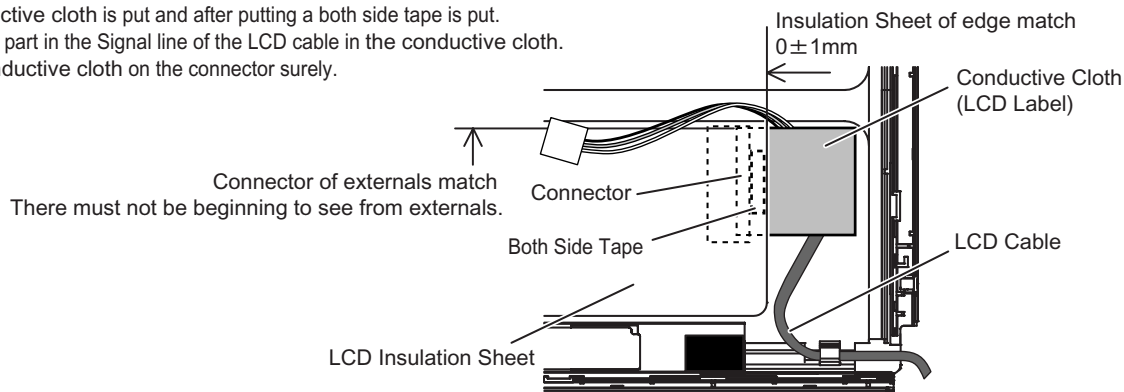

●Putting of PET seat

- The cable must not run aground on the damper.
- Along the LCD module and put the LCD cable (Inverter part) with the PET tape.

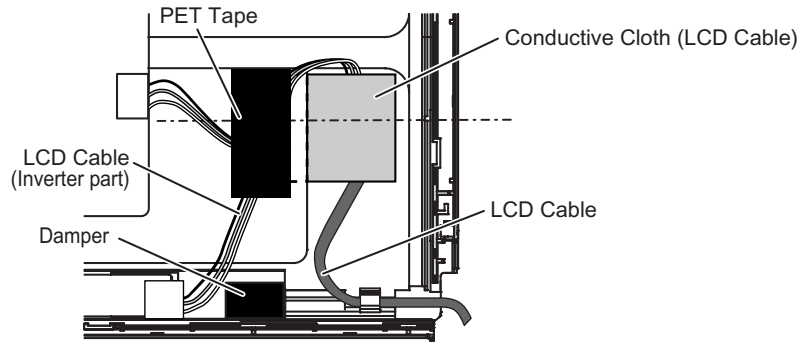

●Putting of rear damper

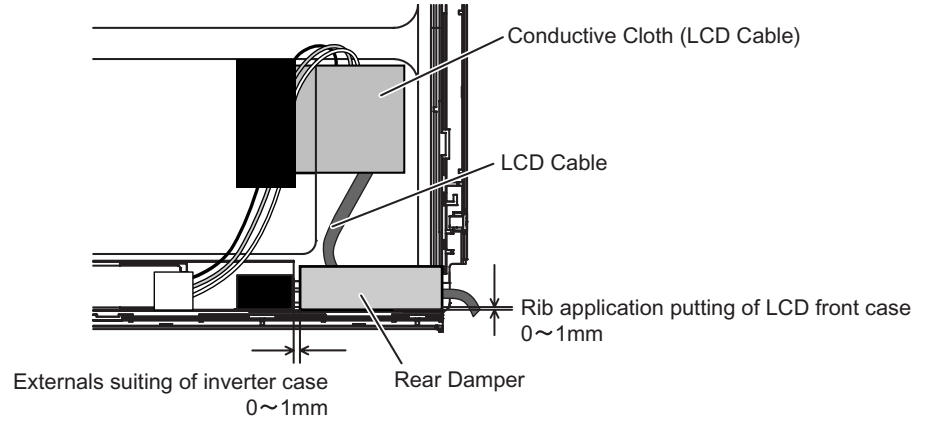

●Processing of inverter cable

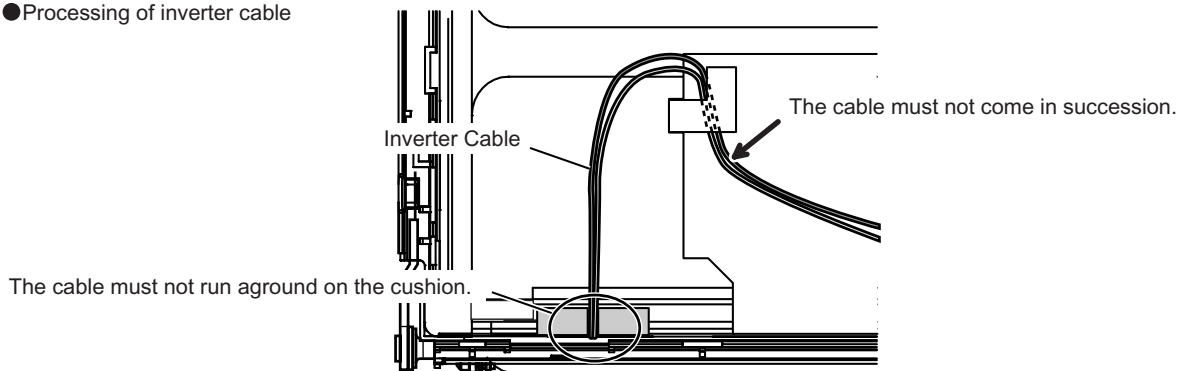

●Putting of gasket (LCD)

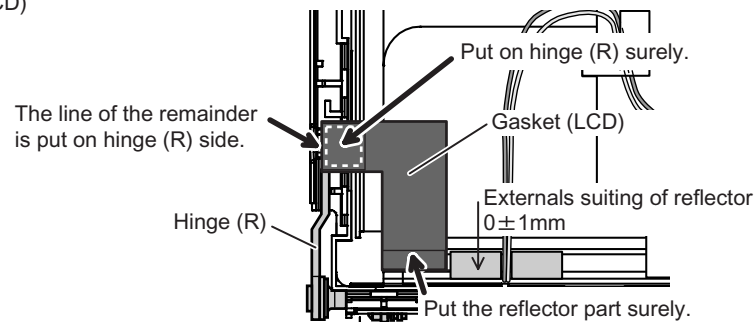

●Putting of LCD damper(C)

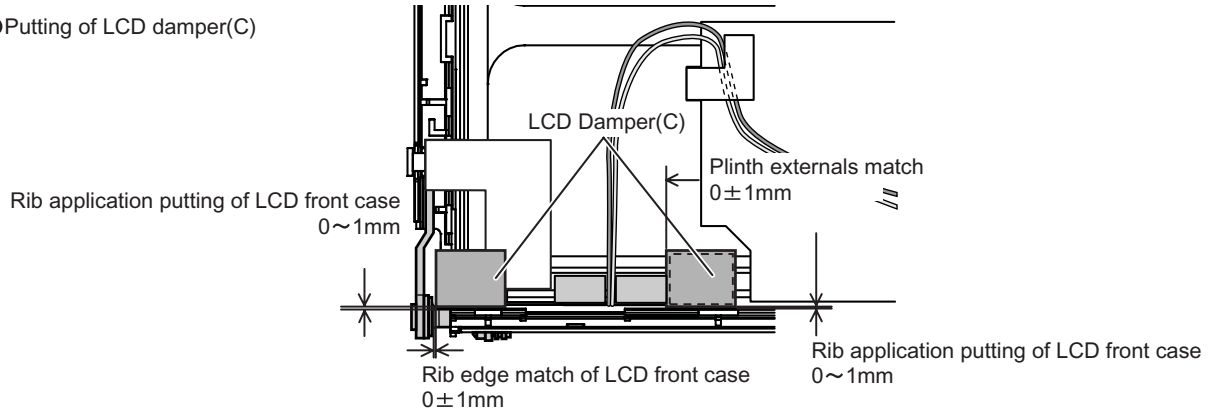

●Drawing out specification of LCD cable
LCD Cable (Touch Panel)

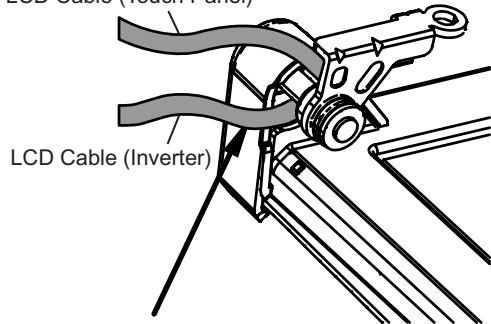

The cable is processed under the shaft .

Note:It is confirmed that the cable does not narrow between cabinets.

●Putting of conductive cloth of LCD cable

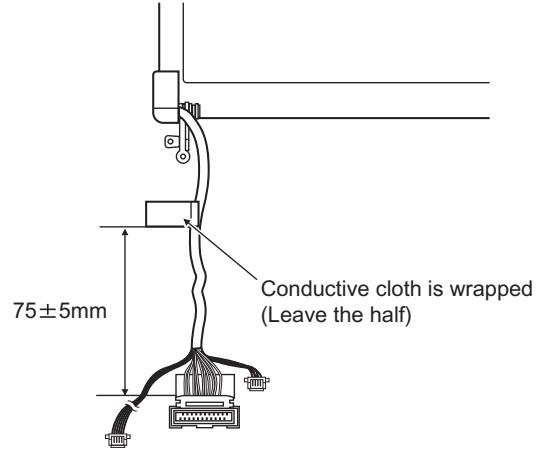

●LCD cable processing

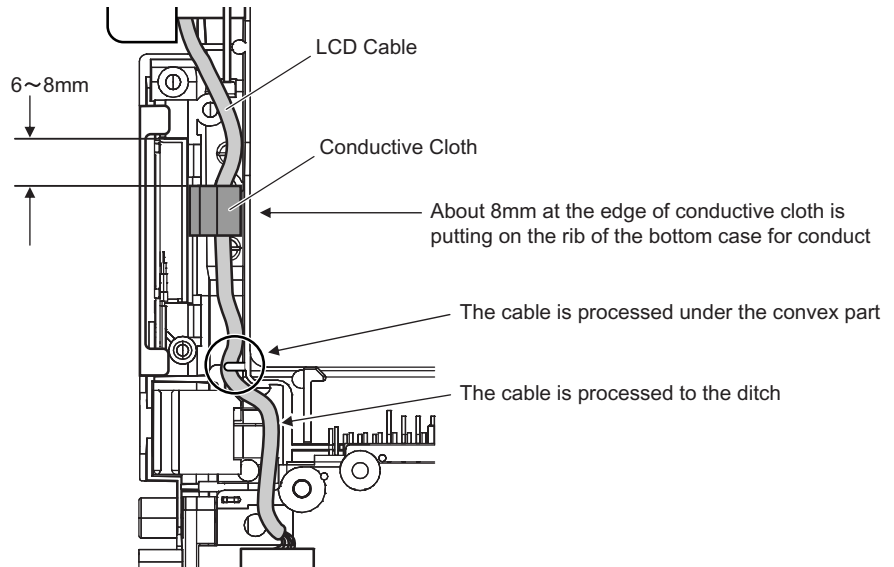

3.3. Installation and Line processing of Speaker

■ Putting of speaker fixation ring

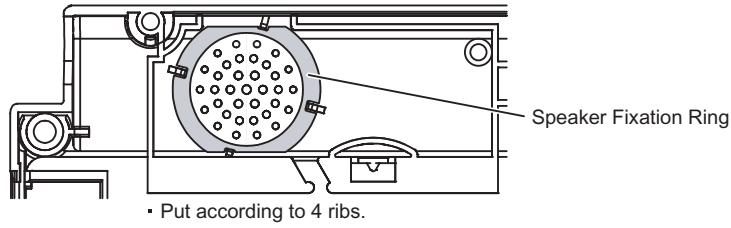

■ Processing of speaker cable

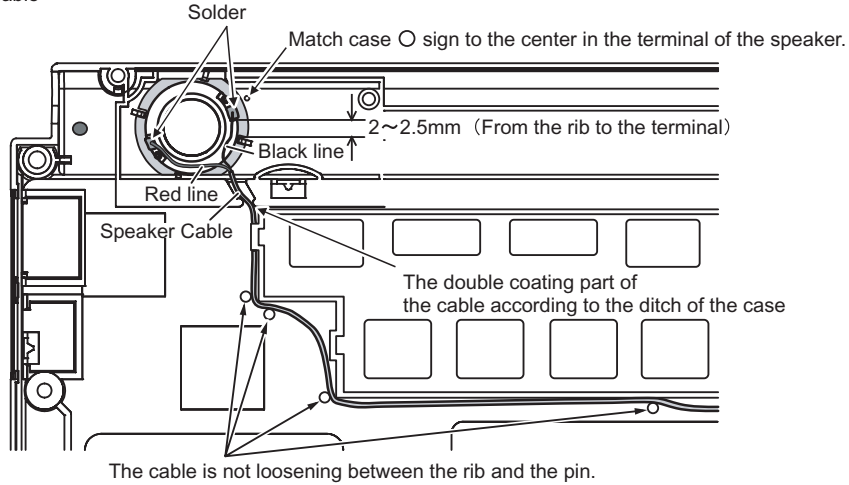

■ Putting of speaker box

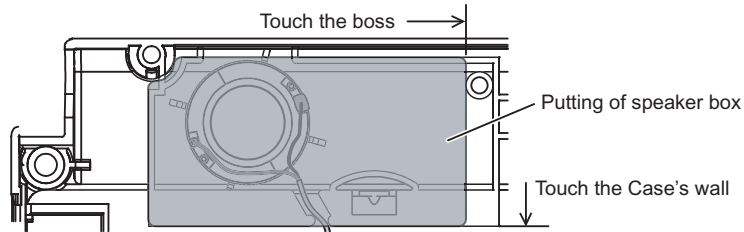

3.4. Assembly of Touch Pad

■ Insertion of PAD FFC

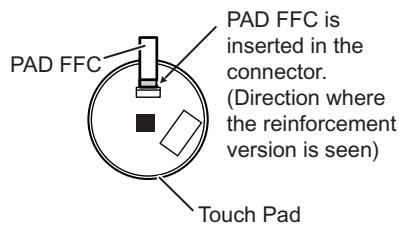

■ Installation of pad button

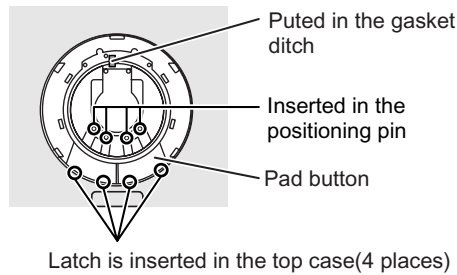

■ Putting of PAD sheet

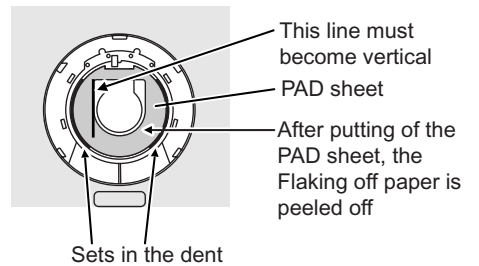

■ Putting of touch pad

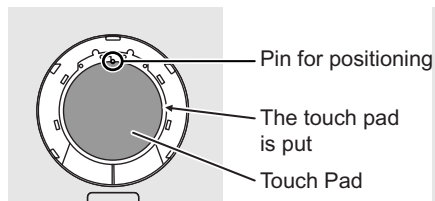

■ Putting of pad cover

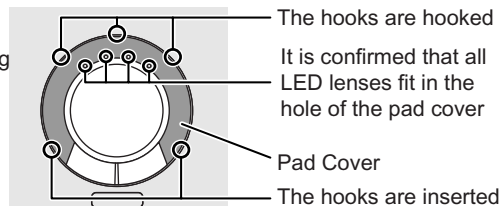

3.5. Processing of DC-IN Cable and Coaxial Cable

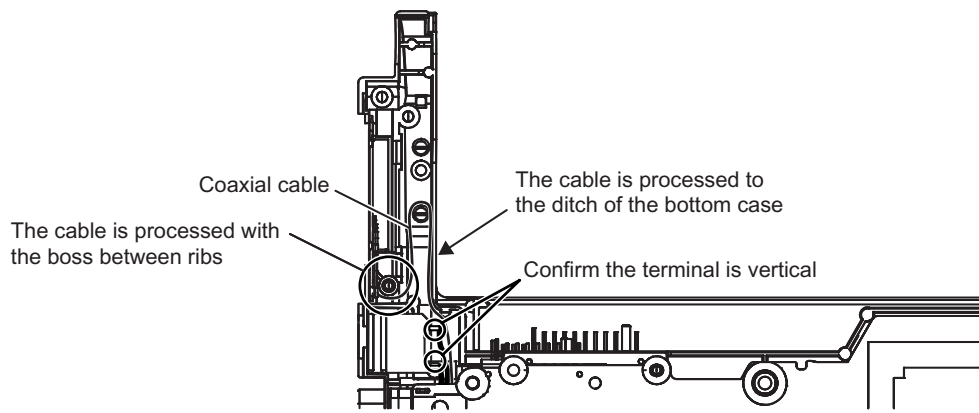

3.6. Obtaining of Side Cover (L)

The upper part is shut with lower hooks put on the bottom case.

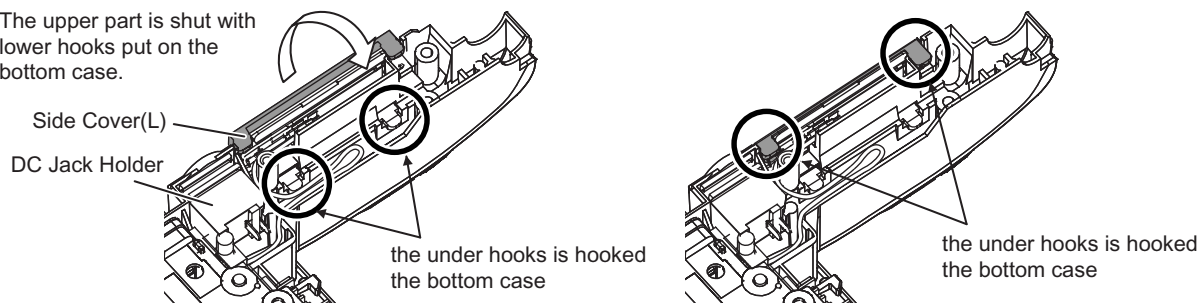

3.7. Processing of MODEM Cable and LAN Cable

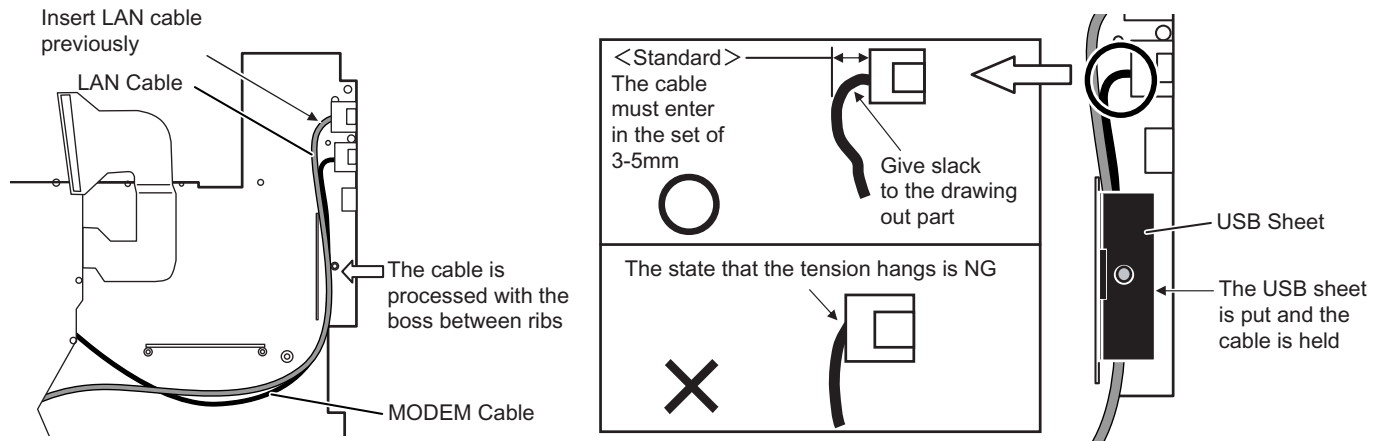

3.8. Processing of USB Cable

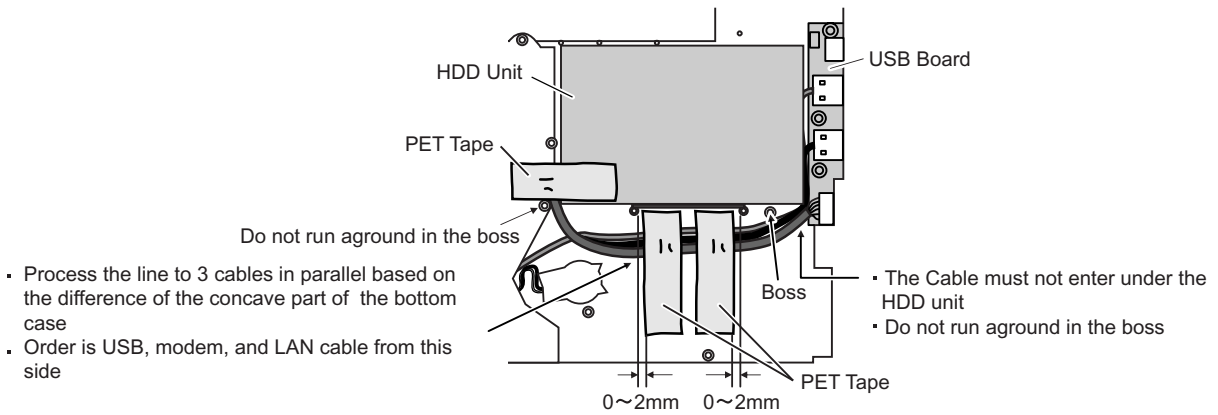

3.9. Screw tightening procedure of Each Unit

When serving, the screw tightening is executed according to the undermentioned procedure.

1. Screw tightening of top case

1-1. DXQT2+E6FNL(K:N12) is tightened. No.1 to No.3

1-2. DXQT26+D8FCL(L:N15) is tightened. No.4 ,No.5

1-3. DXHM0056ZA(J:N6) is tightened. No.6

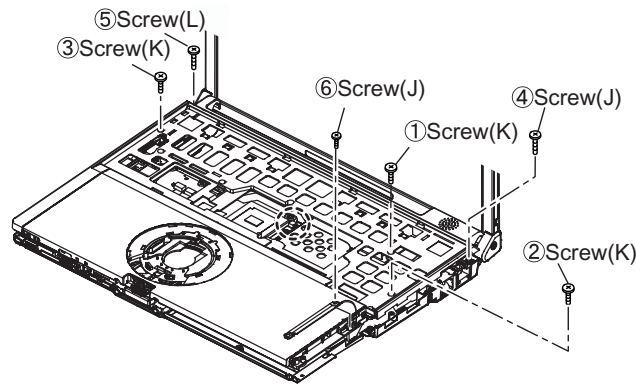

2. Screw tightening of bottom case (1)

The keyboard is inserted, and after the keyboard hooks are inserted in order of a and b while holding the keyboard, the screw tightening is done in the following order.

Note: The sheet metal must not run a ground on the rib (Refer to the figure below).

2-1. DXHM0039ZA(D:N5) is tightened. No.1 to No.7

2-2. DXHM0057ZA(G:N7) is tightened. No.8 to No.12

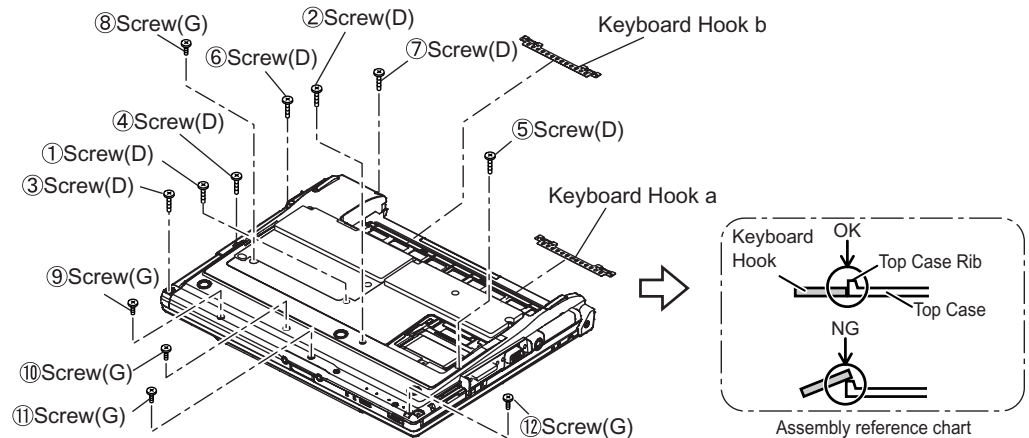

3. Screw tightening of bottom case (2)

The keyboard is inserted, and after tightening of the screw, the keyboard hooks are inserted in order of the following.

- 3-1. DXQT2+E12FNL(B:N11) is tightened. No.1 to No.4
- 3-2. DXQT2+D4FNL(F:N9) is tightened. No.5
- 3-3. DXQT2+E10FNL(E:N10) is tightened. No.6
- 3-4. DFHE5035ZA(H:N2) is tightened. No.7
- 3-5. DFHE5025XA(C:N501) is tightened. No.8
- 3-5. KIYE50000022(I:N500) is tightened. No.9

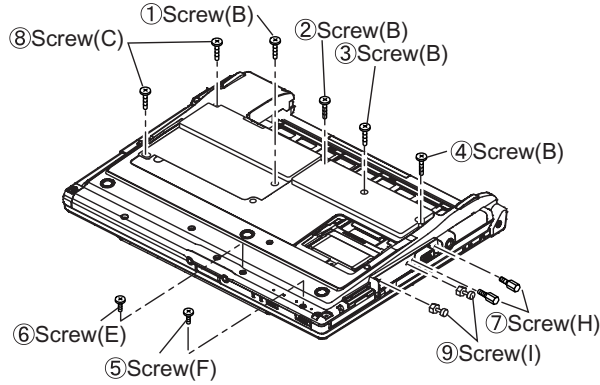

3.10. Affixation of Win Logo Label (XP), CENTRINO Label and Energy Star Label

In the inclination at the time of putting the win logo label, the CENTRINO label and energy star label the both ends difference is within 0.2mm

<Attention>
Confirm whether the paste of the label has overflowed after the win logo label and putting of the CENTRINO label and energy star label.

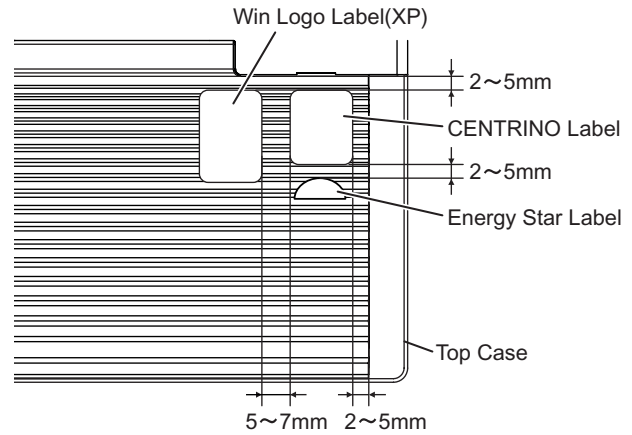

Exploded View

Display Section

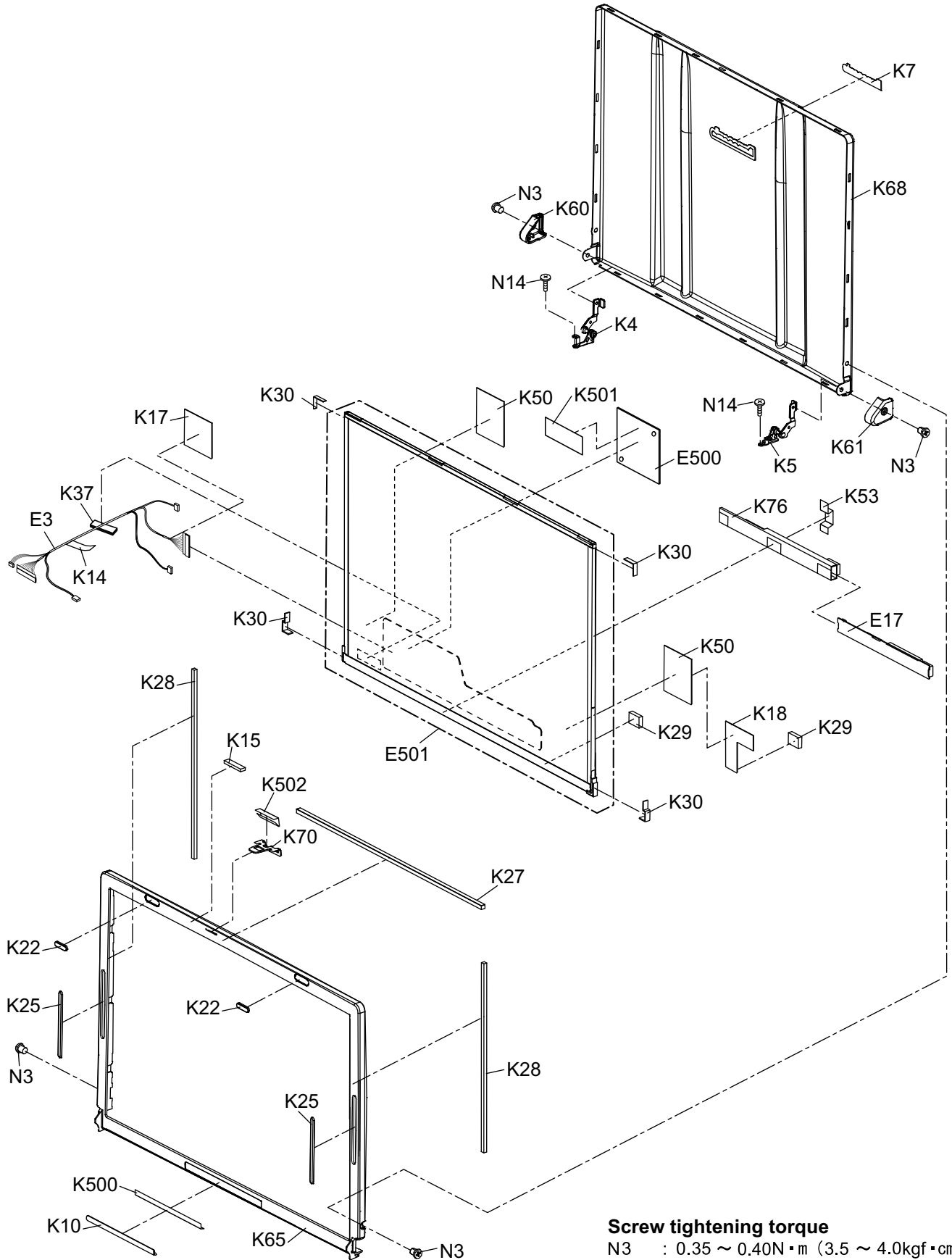

Screw tightening torque
N3 : 0.35 ~ 0.40N·m (3.5 ~ 4.0kgf·cm)
N14 : 0.45 ~ 0.55N·m (4.5 ~ 5.5kgf·cm)

Cabinet Section

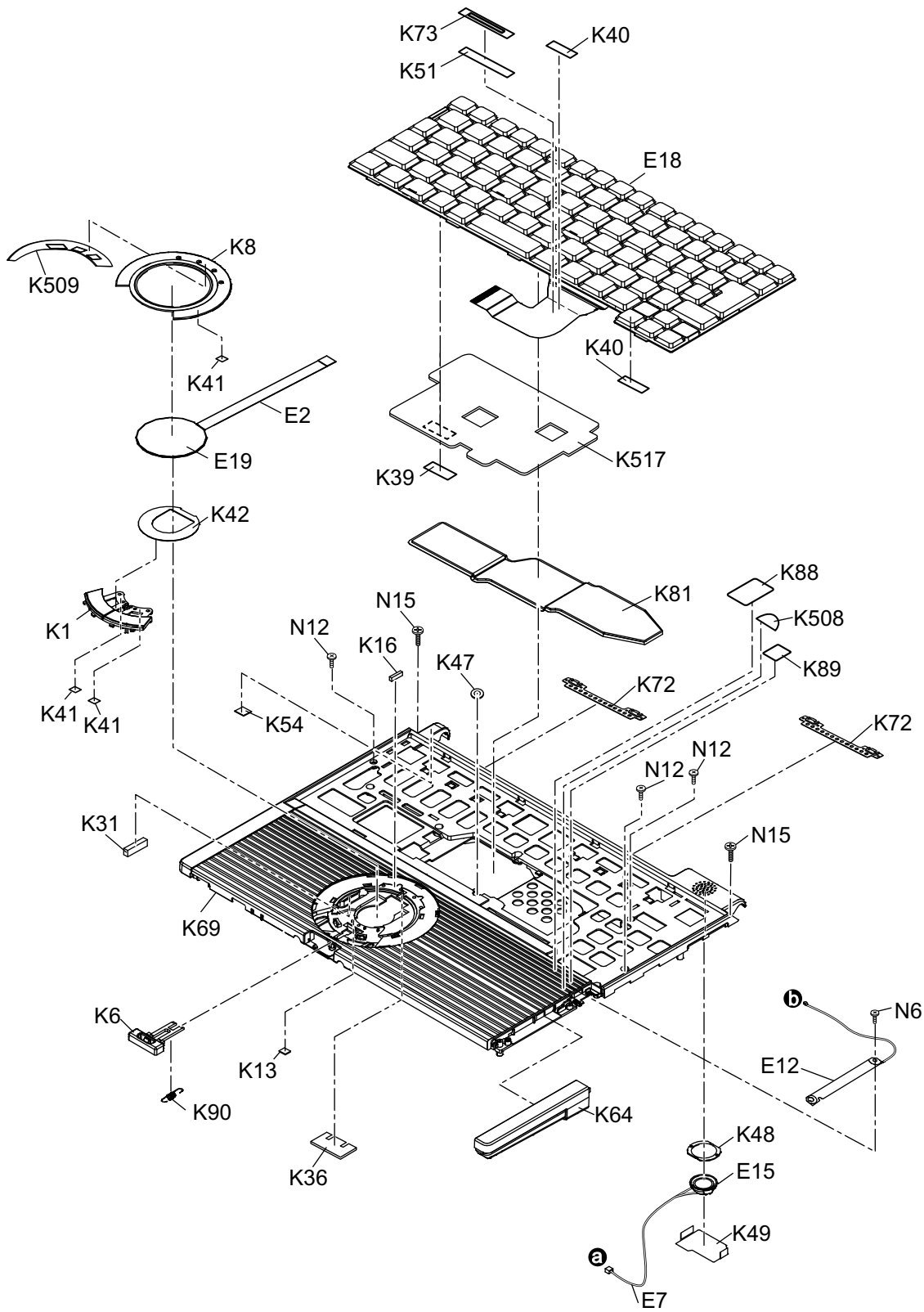

Screw tightening torque

N6	: 0.10 ~ 0.12N·m (1.0 ~ 1.2kgf·cm)
N12	: 0.18 ~ 0.22N·m (1.8 ~ 2.2kgf·cm)
N15	: 0.45 ~ 0.55N·m (4.5 ~ 5.5kgf·cm)

Bottom Section

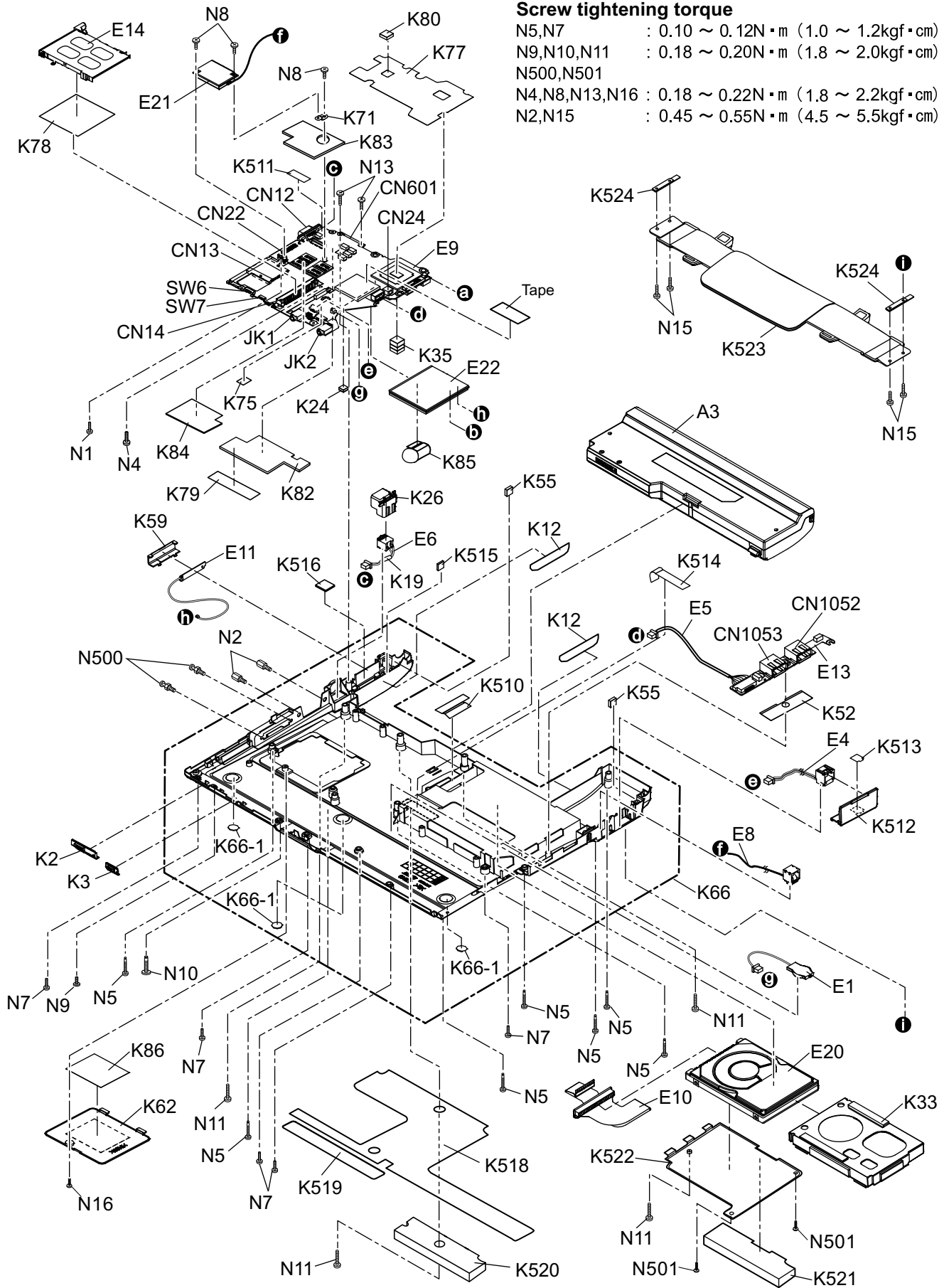

Screw tightening torque





- N5,N7 : 0.10 ~ 0.12N·m (1.0 ~ 1.2kgf·cm)
- N9,N10,N11 : 0.18 ~ 0.20N·m (1.8 ~ 2.0kgf·cm)
- N500,N501
- N4,N8,N13,N16 : 0.18 ~ 0.22N·m (1.8 ~ 2.2kgf·cm)
- N2,N15 : 0.45 ~ 0.55N·m (4.5 ~ 5.5kgf·cm)

Replacement Parts List

Note: Important Safety Notice

Components identified by  mark have special characteristics important for safety. When replacing any of these components, use only manufacturer's specified parts.

CF-T4GWCTZBM

REF.NO. and AREA	PART NO.	DESCRIPTION	Q'TY
Main Block Unit			
E1	 CR2032/S5Y	LITHIUM BATTERY	1
E2	DFJK12U112BB	PAD FFC	1
E3	DFJS963ZA	TP CABLE	1
E4	DFJS958ZB	LAN CABLE	1
E5	DFJS980ZA	MAIN-SUB CABLE	1
E6	DFJS961ZB	DC-IN CABLE	1
E7	DFJS962ZA	SP CABLE	1
E8	DFJS973ZA	MODEM CABLE	1
E9	DL3UP1436LAA	PCB, MAIN	RTL 1
E10	DL3UP1443AAA	FPC UNIT, HDD	1
E11	N1ZYYY000002	ANTENNA PCB-L ASS'Y	1
E12	N1ZYYY000003	ANTENNA PCB-R ASS'Y	1
E13	DL3UP1477AAA	PCB, 2-PORT USB	RTL 1
E14	K1YYZZ000060	CONNECTOR	1
E15	L0AA01A00018	SPEAKER	1
E17	 N0GB1J000012	INVERTER	1
E18	N2AZZJ000038	KEY BOARD US	1
E19	N2EAYYY00001	TOUCH PAD	1
E20	N3CABRD00011	HDD	1
E21	N5HAZ0000012	MODEM	1
E22	N5HZC0000014	WIRELESS LAN MODULE	1
E500	DL3UP1498LAA	PCB, TS	RTL 1
E501	DFWV08A0077	LCD UNIT ASS'Y	1
E501-1	DFWV84A0263	TOUCH SCREEN PANEL KIT	1
E501-1-1	DFHG1824ZA	FRONT TP CUSHION A	2
E501-1-2	DFHG1825YA	FRONT TP CUSHION B	2
E501-1-3	DFHG1826ZA	FRONT TP CUSHION C	1
E501-1-4	DFHG1837ZA	FRONT TP CUSHION D	2
E501-1-5	DFHG1849ZA	FRONT TP CUSHION E	1
E501-2	DFHR3630ZA	TS FPC SPACER	1
Accessories			
A1	 CF-AA1623AM6	AC ADAPTOR	1
A2	 K2CG3DR00003	AC CABLE	1
A3	 CGR-B/979A	LITHIUM ION BATTERY PACK	1
A4	 DFQX5573ZA	MANUAL	1
A500	DFJS954ZA	MODEM CABLE	1
A501	DFHR9081XA	PEN	1
A502	DFME0148ZA	TETHER T4	1
A503	DFHS9017ZA	CLOTH ASS'Y	1
Packing Material			
P1	DFPE0806ZA	HOLDER	1
P2	DFPE0812ZA	PAD W	1
P4	DFPK1037ZA	ACCESSORIES BOX	1
P5	DFPK1180YA	PACKING CASE	1
P6	DFPN0832ZA	CUSHION T	2
P7	DFPN0833ZA	CUSHION B	2
Mechanical Parts			
K1	DFBC0315ZD-0	PAD BUTTON	1
K2	DFBD0180ZB-0	POWER KNOB	1
K3	DFBD0182ZA-0	LAN SW KNOB	1
K4	DFBH3041ZA	HINGE-L TP	1

K5	DFBH3042ZA	HINGE-R TP	1
K6	DFBS0068ZC-0	LCD KNOB	1
K7	DFGB0089VB-0	PANASONIC LABEL	1
K8	DFGE0108ZB-0	PAD COVER	1
K10	DFHG1811ZA	LCD BATT RUBBER TP	1
K12	DFGX0428ZA-0	BATT SHEET(T4)	2
K13	DFHE0215ZA	SHEET	1
K14	DFHE0436ZA	CLOTH LCD CABLE 1	1
K15	DFHE0843ZA	LCD MAGNET	1
K16	DFHE0844ZA	GASKET PAD	1
K17	DFHE0943ZA	GASKET CLOTH (LCD CABLE)	1
K18	DFHE0945ZA	GASKET CLOTH (LCD)	1
K19	DFHE0953ZA	SHEET	1
K22	DFHG1546ZB-0	LCD RUBBER	2
K24	DFHG1744ZA	M-PCI CUSHION	1
K25	DFHG1766ZA-0	LCD SIDE RUBBER	2
K26	DFHG1767ZA-0	DC JACK HOLDER	1
K27	DFHG1771ZA	LCD DAMPER A	1
K28	DFHG1821ZA	LCD DAMPER B TP	2
K29	DFHG1773ZA	LCD DAMPER C	2
K30	DFHG1822ZA	LCD SIDE DAMPER TP	4
K31	DFHG1778ZA	PCMCIA STOPPER CUSHION	1
K33	DFHG1809ZA	HDD CASE ASS'Y T4 USA	1
K35	DFHG1786ZA	CPU CUSHION	1
K36	DFHG1787ZA	MINI-PCI CUSHION	1
K37	DFHG1797ZA	REAR DAMPER	1
K39	DFHP7098ZA	KB TAPE	1
K40	DFHP7106YA	BOTH SIDES TAPE	2
K41	DFHP7140ZA	TAPE, CPU	3
K42	DFHP7221YA	PAD SHEET	1
K47	DFHR3416ZA	SPACER CU	1
K48	DFHR3A37ZA	SPEAKER RING	1
K49	DFHR3A39ZA	SPEAKER BOX	1
K50	DFHR3A78ZA	LCD INSULATOR	2
K51	DFHR3A88ZA	KB PLATE SHEET	1
K52	DFHR3C25ZA	USB SHEET US	1
K53	DFHR3A95ZA	INVERTER TAPE	1
K54	DFHR3B19ZA	HINGE BACKUP SHEET T4	1
K55	DFHR3B22ZA	BOTTOM BACKUP SHEET	2
K59	DFKE0772ZA-0	ANTENNA COVER-L	1
K60	DFKE0776ZA-0	HINGE COVER-L TP	1
K61	DFKE0777ZA-0	HINGE COVER-R TP	1
K62	DFKE0778ZA-0	DIMM COVER (LIGHT)	1
K64	DFKE0783ZA-0	SIDE COVER-R	1
K65	DFKF0257ZA-0	LCD FRONT TP	1
K66	DFKF8166ZA-0	BOTTOM CASE USA ASS'Y	1
K66-1	DFHG371ZA-1	FOOT RUBBER	3
K68	DFKM0482ZA-0	LCD REAR (SANKI)	1
K69	DFKM8172XA-0	TOP CASE ASS'Y	1
K70	DFMD1196ZA	LCD HOOK TP	1
K71	DFMD3121ZA	MDC PLATE	1
K72	DFMD4057ZA	KB HOOK F999	2
K73	DFMD7A52ZA	KB PLATE	1
K75	DFMX0635ZB	TAPE	1
K76	DFMX1155ZA	INVERTER BOX	1
K77	DFMX1156ZA	MAIN PW SHEET1	1
K78	DFMX1160ZA	PCMCIA-MAIN SHEET	1
K79	DFMX1184ZA	SW CABLE SHEET	1
K80	DFMY0399ZA	MCH RUBBER	1
K81	DFMY3191YA	HEAT SPREADER TOP	1

K82		DFMY3192ZA	HEAT SPREADER BOTTOM	1
K83		DFMY3206ZA	MEMORY SHEET TOP	1
K84		DFMY3207ZA	MEMORY SHEET BOTTOM	1
K85		DFMY3208ZA	W-LAN SHEET	1
K86		DFQT6299YA	DIMM COVER SHEET	1
K88		DFQT9950ZA	WINDOWS XP LABEL (FOR NOTE)	1
K89		DFQT9948ZA	CENTRINO LABEL	1
K90		DFUD0040ZA	LATCH SPRING	1
K500		DFHR3C02ZA	BATT RUBBER TAPE	1
K501		DFHR3C01ZA	TAPE TP	1
K502		DFHG1836ZA	LCD HOOK CUSHION TP	1
K503		DFHG1810ZA-0	PEN HOLDER	1
K504		DFHP7223ZA	PEN HOLDER TAPE	1
K505		DFHG1848ZA	PEN FIX CUSHION	1
K506		DFHR3C48ZA	PEN FIX SHEET	1
K507		DFHR3C44ZA	HOLDER BOTTOM SHEET	1
K508		DFQT9675ZA	ENERGY STAR LABEL	1
K509		DFHP7220ZA	PAD COVER TAPE	1
K510		DFHR3B98ZA	HDD FPC SHEET	1
K511		DFHR3C33YA	LCD CABLE FIX SHEET	1
K512		DFKE0781ZA-0	RJ DUST COVER	1
K513		DFHP7228ZA	RJ DUST COVER FIX TAPE	1
K514		DFHR3C13ZA	RJ CABLE SHEET	1
K515		DFHR3C34ZA	TP CABLE FIX SHEET	1
K516		DFHG1847ZA	TP CABLE FIX CUSHION	1
K517		DFMY0421ZA	HEAT SHEET KB LARGE	1
K518	⚠	DFGT1032ZA	BOTTOM SHEET USA	1
K519	⚠	DFGT1075ZA	BOTTOM SHEET USA 2	1
K520		DFGX0430ZA-0	BOTTOM HEAT SHEET	1
K521		DFGX0444ZA-0	HDD COVER HEAT SHEET	1
K522		DFKE0782ZA-0	HDD COVER	1
K523		DFKH1016ZA-0	HANDY STRAP	1
K524		DFMD1191YA	HANDY STRAP ANGLE	2
K525		DFHR9063ZA	PROTECTIVE FILM	1
N1		DFHE5025XA	SCREW	1
N2		DFHE5035ZB	SCREW	2
N3		DRHM0076ZA	SCREW	4
N4		DRQT2+G6FKL	SCREW	1
N5		DXHM0039ZA	SCREW	7
N6		DXHM0056ZA	SCREW	1
N7		DXHM0057ZA	SCREW	5
N8		DXQT2+D25FNL	SCREW	3
N9		DXQT2+D4FNL	SCREW	1
N10		DXQT2+E10FNL	SCREW	1
N11		DXQT2+E12FNL	SCREW	4
N12		DXQT2+E6FNL	SCREW	3
N13		DXQT2+E6FNL	SCREW	2
N14		DXQT26+D5FNL	SCREW	2
N15		DXQT26+D8FCL	SCREW	6
N16		XSB2+4FNL	SCREW	1
N500		K1YE50000022	SCREW, I/O PIN	2
N501		DFHE5025XA	SCREW	2

Replacement Parts List

Note: Important Safety Notice

Components identified by Δ mark have special characteristics important for safety.
When replacing any of these components use only manufacturer's specified parts.

CF-T4GWCTZBM

REF. NO and AREA	PART NO.	DESCRIPTION	Q'TY
MAN PCB			
C 2	F1J0J106A024	CAPACITOR, 6.3V, 10 μ F	40
C 3			
C 4			
C 6			
C 7			
C 8			
C 11			
C 12			
C 13			
C 15			
C 16			
C 17			
C 19			
C 20			
C 21			
C 23			
C 24			
C 25			
C 26			
C 29			
C 30			
C 31			
C 32			
C 34			
C 35			
C 36			
C 37			
C 40			
C 41			
C 42			
C 43			
C 45			
C 46			
C 47			
C 48			
C 63			
C 66			
C 67			
C 100			
C 103			
C 5	EEFCD0D151ER	CAPACITOR, 2V, 150 μ F	2

C 688			
C 9	F1G1C104A042	CAPACITOR, 16V, 0.1μF	157
C 10			
C 14			
C 18			
C 22			
C 27			
C 33			
C 38			
C 39			
C 44			
C 60			
C 61			
C 69			
C 71			
C 72			
C 73			
C 78			
C 79			
C 80			
C 82			
C 83			
C 86			
C 91			
C 92			
C 101			
C 104			
C 110			
C 113			
C 115			
C 116			
C 119			
C 120			
C 121			
C 122			
C 125			
C 126			
C 127			
C 128			
C 131			
C 132			
C 134			
C 135			
C 138			
C 139			
C 142			
C 143			
C 144			
C 152			
C 153			

C 154
C 155
C 161
C 162
C 163
C 164
C 165
C 166
C 167
C 171
C 187
C 195
C 196
C 197
C 200
C 202
C 203
C 206
C 207
C 210
C 211
C 213
C 214
C 215
C 217
C 220
C 221
C 222
C 223
C 228
C 229
C 230
C 231
C 232
C 233
C 234
C 235
C 236
C 237
C 239
C 241
C 242
C 246
C 247
C 249
C 250
C 253
C 257
C 258
C 270

C 278
C 279
C 280
C 281
C 283
C 284
C 293
C 304
C 307
C 308
C 309
C 311
C 313
C 314
C 315
C 316
C 317
C 318
C 319
C 323
C 328
C 329
C 331
C 332
C 333
C 334
C 336
C 337
C 338
C 339
C 341
C 342
C 343
C 345
C 346
C 349
C 350
C 388
C 391
C 392
C 394
C 399
C 401
C 402
C 403
C 408
C 409
C 412
C 417
C 442

C 443 C 444 C 446 C 605 C 609 C 625 C 631 C 702			
C 49 C 54 C 74 C 81 C 89 C 90 C 102 C 106 C 107 C 111 C 169 C 174 C 180 C 181 C 184 C 251 C 291 C 292 C 352 C 353 C 354 C 355 C 356 C 404 C 723	F1J0J106A013	CAPACITOR, 6.3V, 10 μ F	25
C 50 C 170 C 172 C 173 C 175 C 178 C 179 C 182 C 183 C 201 C 219 C 238 C 262 C 264 C 266 C 296 C 305	F1G1E103A062	CAPACITOR, 25V, 0.01 μ F	26

C 327 C 369 C 376 C 378 C 385 C 601 C 678 C 729 C 730			
C 55	F1G1H222A450	CAPACITOR, 50V, 2200pF	1
C 56 C 57 C 191	F1G1A104A014	CAPACITOR, 10V, 0.1μF	3
C 70 C 88 C 112 C 145 C 168 C 185	F1H0J1050022	CAPACITOR, 6.3V, 1μF	6
C 75 C 255 C 256 C 297 C 298 C 325 C 326 C 359 C 387 C 389 C 390 C 395 C 396 C 397 C 407 C 418 C 419 C 420 C 421 C 422 C 423 C 616 C 621 C 632 C 633 C 659 C 667 C 679 C 690	F1G1H102A450	CAPACITOR, 50V, 1000pF	29
C 76 C 77	EEFUD0D331ER	CAPACITOR, 2V, 330μF	4

C 84			
C 85			
C 87	EEFSX0D271ER	CAPACITOR, 2V, 270µF	4
C 648			
C 649			
C 650			
C 93	F1G1A474A018	CAPACITOR, 10V, 0.47µF	7
C 94			
C 95			
C 97			
C 98			
C 99			
C 254			
C 96	F1G0J224A001	CAPACITOR, 6.3V, 0.22µF	5
C 109			
C 300			
C 301			
C 360			
C 105	EEFCD0D101ER	CAPACITOR, 2V, 100µF	4
C 652			
C 686			
C 696			
C 108	EEFUD0E221ER	CAPACITOR, 2.5V, 220µF	3
C 212			
C 218			
C 114	DCUM1A1051BD	CAPACITOR, 10V, 1µF	25
C 117			
C 118			
C 123			
C 124			
C 129			
C 130			
C 133			
C 136			
C 137			
C 156			
C 157			
C 158			
C 159			
C 192			
C 198			
C 199			
C 204			
C 248			
C 310			
C 400			
C 606			
C 635			
C 703			
C 706			

C 140 C 141	F1G1H3R3A475	CAPACITOR, 50V, 3.3pF	2
C 147 C 294 C 295 C 299 C 393 C 607 C 636 C 637 C 638 C 680	F1G1H101A451	CAPACITOR, 50V, 100pF	10
C 176 C 177 C 611 C 647 C 660 C 664 C 683 C 725	F1G1H220A451	CAPACITOR, 50V, 22pF	8
C 190 C 193	F1G1H4R0A543	CAPACITOR, 50V, 4pF	2
C 259 C 260 C 261 C 263 C 265 C 267 C 268 C 269	F1G1H100A452	CAPACITOR, 50V, 10pF	8
C 271 C 272 C 273 C 274 C 275 C 276 C 277	F1G1H330A451	CAPACITOR, 50V, 33pF	7
C 285 C 302 C 312 C 370 C 373	ECJ2FF1A106Z	CAPACITOR, 10V, 10μF	5
C 288	ERJ2GEJ103X	RESISTOR, 1/16W, 10KΩ	1
C 320 C 322	F1G1H6R0A452	CAPACITOR, 50V, 6pF	2
C 324	F1L3D102A003	CAPACITOR, 2000V, 1000pF	1
C 347 C 348 C 620 C 642	F1J0J4750002	CAPACITOR, 6.3V, 4.7μF	5

C 685			
C 351 C 634	F1G1H471A450	CAPACITOR, 50V, 470pF	2
C 357 C 361 C 362 C 398	F1H1A105A030	CAPACITOR, 10V, 1μF	4
C 358	F1J1A1050021	CAPACITOR, 10V, 1μF	1
C 374 C 663 C 701	F1J0J106A016	CAPACITOR, 6.3V, 10μF	3
C 384 C 627 C 629 C 630	F1G1C473A004	CAPACITOR, 16V, 0.047μF	4
C 386	F1G1A683A014	CAPACITOR, 10V, 0.068μF	1
C 405 C 406	F1G1H470A451	CAPACITOR, 50V, 47pF	2
C 600	F1H1H104A731	CAPACITOR, 50V, 0.1μF	1
C 602 C 641 C 646 C 661 C 662 C 675 C 726	F1G1H221A495	CAPACITOR, 50V, 220pF	7
C 603 C 654	F1H1H103A748	CAPACITOR, 50V, 0.01μF	2
C 604 C 614 C 623 C 671 C 687 C 693 C 714	F1L1E106A017	CAPACITOR, 25V, 10μF	7
C 608	F1J1E105A009	CAPACITOR, 25V, 1μF	1
C 610	F1J1E104A081	CAPACITOR, 25V, 0.1μF	1
C 613 C 676	EEFUD0J101ER	CAPACITOR, 6.3V, 100μF	2
C 615 C 617 C 622 C 655 C 658 C 665 C 682 C 684 C 691 C 700 C 705	F1H1H104A783	CAPACITOR, 50V, 0.1μF	16

C 708			
C 709			
C 712			
C 724			
C 727			
C 618	F1K1E1060001	CAPACITOR, 25V, 10µF	7
C 644			
C 645			
C 653			
C 672			
C 716			
C 717			
C 624	EEFUD0G151ER	CAPACITOR, 4V, 150µF	2
C 673			
C 639	F1G1H681A450	CAPACITOR, 50V, 680pF	1
C 640	F1J1H334A533	CAPACITOR, 50V, 0.33µF	1
C 656	F1H1H182A009	CAPACITOR, 50V, 1800pF	2
C 668			
C 674	F1H1H472A748	CAPACITOR, 50V, 4700pF	1
C 704	F1G1H152A450	CAPACITOR, 50V, 1500pF	1
CF 1	D4CC1103A038	THERMISTOR	1
CN 2	K1MMH2B00003	CONNECTOR	1
CN 3	K1KA02BA0014	CONNECTOR	2
CN 26			
CN 4	K1MN45AA0044	CONNECTOR	1
CN 10	K1KA05BA0014	CONNECTOR	1
CN 11	K1KB30AA0049	CONNECTOR	1
CN 12	K1FB315BA003	CONNECTOR	1
CN 16	K1KA08BA0014	CONNECTOR	1
CN 13	K1NA09E00027	CONNECTOR	1
CN 14	K1NA68E00096	CONNECTOR	1
CN 15	K1MY26BA0001	CONNECTOR	1
CN 18	K1KB12A00099	CONNECTOR	1
CN 19	K1MMC4B00011	CONNECTOR	1
CN 21	K1MN12BA0134	CONNECTOR	1
CN 22	K1FY150BA007	CONNECTOR	1
CN 23	K1KA20BA0114	CONNECTOR	1
CN 24	K1KA04BA0014	CONNECTOR	1
CN 600	K1KA02B00247	CONNECTOR	1
CN 601	K1KA10B00233	CONNECTOR	1
D 1	MA2J72900L	DIODE	4
D 2			
D 3			
D 8			
D 4	B0JDBE000002	DIODE	2
D 641			
D 5	B0ADDH000004	DIODE	6
D 6			
D 7			
D 600			

D 601			
D 603			
D 10	B3ABB0000164	DIODE	4
D 11			
D 12			
D 13			
D 15	B3AKB0000008	DIODE	1
D 16	B3ACB0000020	DIODE	2
D 21			
D 19	B0JCMD000014	DIODE	8
D 610			
D 612			
D 626			
D 628			
D 631			
D 632			
D 635			
D 20	B3ABB0000196	DIODE	1
D 22	B0KB00000044	DIODE	2
D 23			
D 602	MAZ81200ML	DIODE	1
D 604	MAZ81800ML	DIODE	1
D 605	B0JCCE000008	DIODE	3
D 624			
D 630			
D 606	MA3S132E0L	DIODE	2
D 622			
D 609	B0JCQD000001	DIODE	1
D 611	B0JDAE000004	DIODE	2
D 627			
D 613	MAZ80510ML	DIODE	6
D 614			
D 615			
D 617			
D 618			
D 640			
D 616	MAZ80620ML	DIODE	1
D 619	MA2S111-TX	DIODE	2
D 621			
D 620	B2ABAM000002	DIODE	1
D 625	DEDRB081L20	DIODE	1
D 629	B0JCPD000023	DIODE	3
D 642			
D 643			
F 2	⚠ K5H2021A0003	FUSE, 2A	2
F 3			
F 4	⚠ K5H1021A0003	FUSE, 1A	1
IC 1	C2GBC0000263	IC, CPU	1
IC 2	C1DB00001476	IC, CHIP SET	1
IC 4	C3ABSG000030	IC, SDRAM	8

IC 5			
IC 6			
IC 7			
IC 8			
IC 9			
IC 10			
IC 11			
IC 3	C1DB00001359	IC, CHIP SET	1
IC 12	C0JBAZ002423	IC, CLOCK GENERATOR	1
IC 14	C1ZBZ0002445	IC, PC-CARD SW	1
IC 15	C0CBCBG00008	IC, REGULATOR	1
IC 16	C1DB00001182	IC, LAN CONTROLLER	1
IC 17	C3EBCG000100	IC, EEPROM	1
IC 21	C0EBE0000460	IC	3
IC 22			
IC 23			
IC 24	C0EBH0000457	IC	1
IC 25	C0CBCBC00137	IC, REGULATOR	1
IC 26	C2CBJA000003	IC, MICON	1
IC 34	C0JBZZ000327	IC, THERMAL SENSOR	1
IC 36	C3FBLC000040	IC, FLASH MEMORY	1
IC 39	C0JBAB000619	IC, GATE LOGIC	1
IC 40	C0JBAA000344	IC, GATE LOGIC	5
IC 50			
IC 52			
IC 77			
IC 614			
IC 41	C0JBAE000302	IC, LOGIC	3
IC 46			
IC 49			
IC 42	C0JBAA000346	IC, LOGIC	4
IC 43			
IC 73			
IC 74			
IC 44	C1DB00001439	IC, CARDBUS CONTROL	1
IC 55	C0JBZZ000371	IC	2
IC 57			
IC 56	C0DBZH000043	IC, USB POWER CONTROL	2
IC 59			
IC 61	C1BB00001025	IC, AUDIO AMP	1
IC 62	C0ABBA000093	IC, OP AMP	2
IC 601			
IC 63	C0JBAB000616	IC, LOGIC	2
IC 604			
IC 64	C0CBCBC00181	IC	1
IC 65	C1BB00000868	IC, AC97 CODEC	1
IC 600	C0ABZA000047	IC, AMP	1
IC 602	C0DBALH00003	IC	4
IC 606			
IC 607			

IC 610			
IC 603	C0JBAD000182	IC, LOGIC	1
IC 605	C0DBAFH00029	IC	1
IC 608	C0DBEFH00002	IC, REGULATOR	1
IC 609	C0EBE0000333	IC	1
IC 613	C0DBDJH00009	IC, LINER	1
JK 1	K2HC103B0090	JK	2
JK 2			
L 1	G1C100Z00013	INDUCTOR	2
L 2			
L 3	G1C1R0Z00002	INDUCTOR	5
L 4			
L 5			
L 7			
L 8			
L 6	G1C91NM00001	INDUCTOR	1
L 9	J0JJC0000015	INDUCTOR	1
L 10	J0JHC0000074	INDUCTOR	4
L 13			
L 25			
L 47			
L 23	J0MAB0000169	INDUCTOR	2
L 24			
L 26	DDB5Z024E-L	INDUCTOR	2
L 54			
L 27	J0JCC0000186	INDUCTOR	7
L 28			
L 29			
L 30			
L 31			
L 32			
L 33			
L 34	DDB5Z024C-L	INDUCTOR	4
L 35			
L 36			
L 37			
L 45	DDB5Z032A-L	INDUCTOR	2
L 46			
L 48	DDB5Z021C-Y	INDUCTOR	6
L 49			
L 50			
L 51			
L 52			
L 53			
L 600	DDB5Z028C-L	INDUCTOR	1
L 601	DDAZS100MT3T	INDUCTOR	2
L 602			
L 603	G1C1R6Z00001	INDUCTOR	1
L 604	G1C4R7ZA0059	INDUCTOR	1
L 605	G1C220MA0077	INDUCTOR	1

L 607 L 608	G1C4R7MA0022	INDUCTOR	2
L 609	G1A160H00001	INDUCTOR	1
PS 2 PS 1	K5J1BB000001	POLY SW	2
Q 1 Q 3 Q 7 Q 22 Q 27 Q 28 Q 602 Q 608 Q 642 Q 653 Q 654 Q 661 Q 662 Q 663	UNR9214J0L	TRANSISTOR	14
Q 4 Q 8 Q 10 Q 13 Q 17 Q 19 Q 624 Q 625	B1DHDC000028	TRANSISTOR	8
Q 5 Q 6 Q 628 Q 630 Q 644 Q 648 Q 657 Q 670	B1CFGD000004	TRANSISTOR	8
Q 9 Q 12 Q 14 Q 16 Q 29 Q 615 Q 617 Q 618 Q 621 Q 622 Q 623 Q 626	XP0421300L	TRANSISTOR	12
Q 20 Q 21 Q 600	XP0421400L	TRANSISTOR	3

Q 23	B1GFCFEN0003	TRANSISTOR	1
Q 24	DETA144EETL	TRANSISTOR	3
Q 33			
Q 664			
Q 31	UNR9111J0L	TRANSISTOR	1
Q 605	UNR9213J0L	TRANSISTOR	5
Q 606			
Q 620			
Q 659			
Q 669			
Q 607	B1DHFD000015	TRANSISTOR	2
Q 666			
Q 609	B1CHRD000001	TRANSISTOR	2
Q 610			
Q 611	B1DBGD000006	TRANSISTOR	6
Q 613			
Q 632			
Q 646			
Q 655			
Q 665			
Q 614	B1MBEDA00017	TRANSISTOR	3
Q 636			
Q 638			
Q 619	B1DHFB000003	TRANSISTOR	1
Q 629	B1ABCF000023	TRANSISTOR	2
Q 631			
Q 633	B1DFGD000032	TRANSISTOR	1
Q 637	B1CFGD000003	TRANSISTOR	2
Q 660			
Q 645	B1DFED000020	TRANSISTOR	1
Q 650	B1MBEDA00018	TRANSISTOR	1
Q 674	B1CFMC000008	TRANSISTOR	1
R 1	ERJ2GEJ681X	RESISTOR, 1/16W, 680Ω	2
R 252			
R 2	ERJ2RKF27R4X	RESISTOR, 1/16W, 27.4Ω	3
R 15			
R 16			
R 3	ERJ2GEJ151X	RESISTOR, 1/16W, 150Ω	2
R 6			
R 4	ERJ2RKF54R9X	RESISTOR, 1/16W, 54.9Ω	2
R 7			
R 5	ERJ2RKF39R2X	RESISTOR, 1/16W, 39.2Ω	1
R 11	ERJ3GEY0R00V	RESISTOR, 1/16W, 0Ω	4
R 240			
R 335			
R 336			
R 12	ERJ2RKF2000X	RESISTOR, 1/16W, 200Ω	2
R 43			
R 13	ERJ2GEJ560X	RESISTOR, 1/16W, 56Ω	6
R 14			

R 27 R 29 R 31 R 32			
R 17 R 18 R 35 R 36	ERJ2RKF54R9X	RESISTOR, 1/16W, 54.9Ω	4
R 23 R 679 R 703 R 734 R 738 R 780	ERJ3GEYJ100V	RESISTOR, 1/16W, 10Ω	6
R 24	ERJ2RKF1001X	RESISTOR, 1/16W, 1KΩ	1
R 25	ERJ2RKF2001X	RESISTOR, 1/16W, 2KΩ	1
R 26 R 312 R 609 R 613 R 614 R 752	ERJ2GEJ562X	RESISTOR, 1/16W, 5.6KΩ	6
R 28	ERJ2GEJ750X	RESISTOR, 1/16W, 75Ω	1
R 33 R 39	ERJ2RKF2210X	RESISTOR, 1/16W, 221Ω	2
R 34 R 40 R 42	ERJ2RKF1000X	RESISTOR, 1/16W, 100Ω	3
R 37 R 38 R 66 R 232	ERJ2RKF24R9X	RESISTOR, 1/16W, 24.9Ω	4
R 41 R 114 R 115 R 116 R 117 R 118 R 119 R 120 R 121 R 122 R 123 R 124 R 125 R 126 R 127 R 128 R 129 R 130	ERJ2GE0R00X	RESISTOR, 1/16W, 0Ω	62

R 131			
R 132			
R 133			
R 134			
R 135			
R 136			
R 137			
R 138			
R 139			
R 145			
R 147			
R 162			
R 167			
R 169			
R 224			
R 229			
R 235			
R 236			
R 245			
R 246			
R 289			
R 297			
R 330			
R 355			
R 356			
R 366			
R 377			
R 379			
R 383			
R 384			
R 432			
R 434			
R 436			
R 439			
R 442			
R 478			
R 479			
R 480			
R 604			
R 689			
R 693			
R 694			
R 784			
R 786			
R 47 R 48	ERJ2RKF80R6X	RESISTOR, 1/16W, 80.6Ω	2
R 49 R 190 R 191 R 193	ERJ2GEJ103X	RESISTOR, 1/16W, 10KΩ	51

R 198			
R 220			
R 221			
R 225			
R 230			
R 241			
R 243			
R 247			
R 279			
R 293			
R 294			
R 307			
R 308			
R 315			
R 321			
R 322			
R 324			
R 325			
R 342			
R 353			
R 381			
R 382			
R 386			
R 387			
R 399			
R 400			
R 408			
R 412			
R 420			
R 471			
R 616			
R 684			
R 697			
R 698			
R 705			
R 710			
R 711			
R 717			
R 719			
R 722			
R 728			
R 730			
R 731			
R 746			
R 747			
R 776			
R 781			
R 50	ERJ2GEJ222X	RESISTOR, 1/16W, 2.2KΩ	8
R 51			
R 280			

R 281			
R 285			
R 286			
R 340			
R 341			
R 52	ERJ2GEJ101X	RESISTOR, 1/16W, 100Ω	25
R 203			
R 226			
R 228			
R 242			
R 259			
R 288			
R 290			
R 309			
R 319			
R 362			
R 365			
R 401			
R 402			
R 418			
R 449			
R 617			
R 618			
R 651			
R 652			
R 653			
R 654			
R 655			
R 656			
R 788			
R 53	ERJ2RKF1002X	RESISTOR, 1/16W, 10KΩ	1
R 54	ERJ2RKF75R0X	RESISTOR, 1/16W, 75Ω	3
R 55			
R 56			
R 57	D1H82224A024	RESISTOR ARRAY	1
R 58	ERJ2RKF1501X	RESISTOR, 1/16W, 1.5KΩ	1
R 63	ERJ2GEJ390X	RESISTOR, 1/16W, 39Ω	2
R 64			
R 65	ERJ2RKF2550X	RESISTOR, 1/16W, 255Ω	1
R 67	ERJ6GEYJ100V	RESISTOR, 1/10W, 10Ω	1
R 68	ERJ2GEJ201X	RESISTOR, 1/16W, 200Ω	4
R 70			
R 72			
R 74			
R 80	D1HG2208A001	RESISTOR ARRAY	8
R 81			
R 82			
R 83			
R 108			
R 109			

R 110			
R 111			
R 84	ERJ2GEJ220X	RESISTOR, 1/16W, 22Ω	27
R 85			
R 86			
R 87			
R 88			
R 89			
R 90			
R 91			
R 92			
R 93			
R 94			
R 95			
R 96			
R 97			
R 98			
R 99			
R 100			
R 101			
R 102			
R 103			
R 104			
R 105			
R 106			
R 107			
R 350			
R 351			
R 444			
R 112	D1HA56080001	RESISTOR ARRAY	7
R 113			
R 140			
R 141			
R 142			
R 143			
R 144			
R 149	ERJ2GEJ102X	RESISTOR, 1/16W, 1KΩ	12
R 150			
R 151			
R 152			
R 267			
R 300			
R 339			
R 354			
R 425			
R 474			
R 475			
R 677			
R 153	ERJ3GEYJ2R2V	RESISTOR, 1/16W, 2.2Ω	2
R 176			

R 154 R 155 R 156 R 157 R 158 R 159 R 194 R 195 R 196 R 197 R 295 R 313 R 314 R 316 R 317 R 404	ERJ2RKF49R9X	RESISTOR, 1/16W, 49.9Ω	16
R 160 R 161 R 185 R 409	ERJ2GEJ120X	RESISTOR, 1/16W, 12Ω	4
R 166 R 178 R 179 R 181 R 182 R 183 R 186 R 187 R 188 R 189 R 219 R 265 R 266 R 270 R 271 R 407 R 464 R 465 R 468	ERJ2GEJ330X	RESISTOR, 1/16W, 33Ω	19
R 170	D1H83304A024	RESISTOR ARRAY	1
R 175	ERJ2RKF4750X	RESISTOR, 1/16W, 475Ω	1
R 177 R 248 R 685	ERJ3GEYJ1R0V	RESISTOR, 1/16W, 1Ω	3
R 192 R 217 R 222 R 276 R 277 R 278	ERJ2GEJ104X	RESISTOR, 1/16W, 100KΩ	32

R 287			
R 291			
R 296			
R 299			
R 305			
R 329			
R 346			
R 358			
R 363			
R 369			
R 371			
R 375			
R 388			
R 395			
R 396			
R 413			
R 415			
R 621			
R 622			
R 628			
R 629			
R 646			
R 649			
R 650			
R 789			
R 795			
R 218 R 223 R 256 R 301 R 333 R 410 R 473	D1H81034A024	RESISTOR ARRAY	7
R 231	ERJ2RKF22R6X	RESISTOR, 1/16W, 22.6Ω	1
R 237	ERJ2GEJ203X	RESISTOR, 1/16W, 20KΩ	1
R 238	ERJ2GEJ106X	RESISTOR, 1/16W, 10MΩ	1
R 239 R 318 R 348 R 349 R 627 R 647 R 678 R 683 R 790	ERJ2GEJ105X	RESISTOR, 1/16W, 1MΩ	9
R 249 R 250	ERJ3GEYJ121V	RESISTOR, 1/16W, 120Ω	2
R 392 R 393	ERJ3GEYJ151V	RESISTOR, 1/16W, 150Ω	2
R 253	DEARA8AJ103M	RESISTOR ARRAY	5

R 254 R 255 R 304 R 389			
R 258 R 261 R 263 R 264 R 303 R 344 R 368 R 448 R 623 R 661 R 687 R 773	ERJ2GEJ473X	RESISTOR, 1/16W, 47K Ω	12
R 268 R 269	J0JAC0000021	FILTER	2
R 272 R 441 R 472 R 686 R 756	ERJ2GEJ472X	RESISTOR, 1/16W, 4.7K Ω	5
R 298 R 663 R 664 R 701 R 702 R 706 R 707 R 714 R 715 R 723 R 727 R 732 R 736 R 777 R 778	ERJ2GEJ100X	RESISTOR, 1/16W, 10 Ω	15
R 306 R 372	ERJ2GEJ334X	RESISTOR, 1/16W, 330K Ω	2
R 311	ERJ2RHD562X	RESISTOR, 1/16W, 5.6K Ω	1
R 320	EXBV8V750JV	RESISTOR ARRAY	1
R 323 R 343	ERJ2GEJ273X	RESISTOR, 1/16W, 27K Ω	2
R 326 R 327 R 328	ERJ2GEJ363X	RESISTOR, 1/16W, 36K Ω	3
R 331 R 657	ERJ2GEJ223X	RESISTOR, 1/16W, 22K Ω	2
R 334	ERJ2GEJ333X	RESISTOR, 1/16W, 33K Ω	1

R 347 R 397	ERJ2GEJ471X	RESISTOR, 1/16W, 470Ω	2
R 380	ERJ2RKF3901X	RESISTOR, 1/16W, 3.9KΩ	1
R 385 R 608 R 611	ERJ2RHD103X	RESISTOR, 1/16W, 10KΩ	3
R 390 R 391	ERJ2GEJ561X	RESISTOR, 1/16W, 560Ω	2
R 394	ERJ2GEJ391X	RESISTOR, 1/16W, 390Ω	1
R 398	ERJ2GEJ470X	RESISTOR, 1/16W, 47Ω	1
R 403 R 450	ERJ6GEYJ101V	RESISTOR, 1/10W, 100Ω	2
R 466	ERJ6GEY0R00V	RESISTOR, 1/10W, 0Ω	1
R 600 R 603	ERJ2RHD104X	RESISTOR, 1/16W, 100KΩ	2
R 601 R 602	ERJ2RKD154X	RESISTOR, 1/16W, 150KΩ	2
R 605 R 692	D1ZZ00000046	RESISTOR, 1W, 5mΩ	2
R 606	ERJ3GEYJ562V	RESISTOR, 1/16W, 5.6KΩ	1
R 610	RL1220SR47F	RESISTOR, 1/8W, 0.47Ω	1
R 620	ERJ3GEYJ3R3V	RESISTOR, 1/16W, 3.3Ω	1
R 624 R 625 R 626	RL1220SR15F	RESISTOR, 1/8W, 0.15Ω	3
R 630 R 631 R 695 R 696 R 725 R 726 R 743	D1BDR0220001	RESISTOR, 1/8W, 0.022Ω	7
R 632 R 751 R 762	ERA3YKB104V	RESISTOR, 1/16W, 100KΩ	3
R 633 R 740	ERA3YEB203V	RESISTOR, 1/16W, 20KΩ	2
R 639	ERA3YEB103V	RESISTOR, 1/16W, 10KΩ	1
R 640	ERA3YEB303V	RESISTOR, 1/16W, 30KΩ	1
R 641 R 642 R 741	D1BDR0330001	RESISTOR, 1/8W, 0.033Ω	3
R 644	ERJ2GEJ684X	RESISTOR, 1/16W, 680KΩ	1
R 648	ERJ2GEJ225X	RESISTOR, 1/16W, 2.2MΩ	1
R 658	ERJ6GEYJ561V	RESISTOR, 1/10W, 560Ω	1
R 659 R 660	ERJ6GEYJ222V	RESISTOR, 1/10W, 2.2KΩ	2
R 665 R 671	ERJ2RKF1004X	RESISTOR, 1/16W, 1MΩ	2
R 666	ERJ2RHD223X	RESISTOR, 1/16W, 22KΩ	1

R 667	ERJ2RHD333X	RESISTOR, 1/16W, 33KΩ	1
R 668 R 676	ERJ2RKF1003X	RESISTOR, 1/16W, 100KΩ	2
R 669	ERJ2RHD222X	RESISTOR, 1/16W, 2.2KΩ	1
R 670 R 712	ERJ2RKF5102X	RESISTOR, 1/16W, 51KΩ	2
R 674 R 724	ERJ2RHD123X	RESISTOR, 1/16W, 12KΩ	2
R 672	ERJ2RHD133X	RESISTOR, 1/16W, 13KΩ	1
R 680 R 688	ERJ2GEJ154X	RESISTOR, 1/16W, 150KΩ	2
R 681	ERJ2GEJ513X	RESISTOR, 1/16W, 51KΩ	1
R 682	ERJ2GEJ302X	RESISTOR, 1/16W, 3KΩ	1
R 691 R 742	ERA3YEB243V	RESISTOR, 1/16W, 24KΩ	2
R 699 R 763	ERA3YEB333V	RESISTOR, 1/16W, 33KΩ	2
R 704 R 716 R 739 R 775	ERJ2GEJ153X	RESISTOR, 1/16W, 15KΩ	4
R 708	ERJ2RKF4701X	RESISTOR, 1/16W, 4.7KΩ	1
R 709 R 733	ERJ2RKF1502X	RESISTOR, 1/16W, 15KΩ	2
R 713	ERJ2RKF2402X	RESISTOR, 1/16W, 24KΩ	1
R 720	D1BDR0470002	RESISTOR, 1/8W, 0.047Ω	1
R 729	ERA3YEB622V	RESISTOR, 1/16W, 6.2KΩ	1
R 759 R 760	D1BDR0680001	RESISTOR, 1/8W, 0.068Ω	2
R 735	ERJ2GEJ221X	RESISTOR, 1/16W, 220Ω	1
R 737	ERA3YEB471V	RESISTOR, 1/16W, 470Ω	1
R 744 R 754 R 774	ERJ2GEJ474X	RESISTOR, 1/16W, 470KΩ	3
R 748	ERJ2RKD114X	RESISTOR, 1/16W, 110KΩ	1
R 749	ERJ2RKF1503X	RESISTOR, 1/16W, 150KΩ	1
R 750	ERJ2RHD3652X	RESISTOR, 1/16W, 36.5KΩ	1
R 757 R 758	ERJ2RHD302X	RESISTOR, 1/16W, 3KΩ	2
R 768	ERJ2RHD132X	RESISTOR, 1/16W, 1.3KΩ	1
R 769 R 772	ERJ2RKF1102X	RESISTOR, 1/16W, 11KΩ	2
R 771	ERJ2RKF1302X	RESISTOR, 1/16W, 13KΩ	1
R 779	ERA3YEB621V	RESISTOR, 1/16W, 620Ω	1
R 793 R 794	ERJ1TYJ331U	RESISTOR, 1W, 330Ω	2
SW 5	KOZZ00000617	SW	1
SW 6	ESD165225	SW	1
SW 7	K0D112B00071	SW	1
SW 8	EVQPLDA15	SW	2

SW 9			
T 1	G5BYC0000010	TRANCE	1
X 1	H0J143500058	OSCILLATOR, 14.318MHz	1
X 2	H0J327200141	OSCILLATOR, 32.768MHz	1
X 3	H0J250500025	OSCILLATOR, 25MHz	1
X 4	H2D800400015	OSCILLATOR, 8MHz	1
ZA 1	DRHM0100ZA	SPACER	1
ZA 2	DRHM0099ZA	SPACER	1
USB PCB			
C 1051	EEFUD0J151ER	CAPACITOR, 6.3V, 150µF	2
C 1052			
CN 1051	K1KA12BA0014	CONNECTOR	1
CN 1052	K1FB104B0055	CONNECTOR	2
CN 1053			
D 1051	B0KB00000044	DIODE	2
D 1052			
L 1051	J0MAB0000116	INDUCTOR	2
L 1052			
L 1053	J0JHC0000074	INDUCTOR	4
L 1054			
L 1055			
L 1056			
TS PCB			
C 1101	F1G1E472A062	CAPACITOR, 25V, 4700pF	4
C 1102			
C 1103			
C 1104			
C 1105	F1G1H681A450	CAPACITOR, 50V, 680pF	4
C 1106			
C 1107			
C 1108			
C 1109	F1G1C104A042	CAPACITOR, 16V, 0.1µF	3
C 1112			
C 1113			
C 1110	F1G1E223A062	CAPACITOR, 25V, 0.022µF	1
C 1111	F1G1H102A450	CAPACITOR, 50V, 1000pF	1
C 1114	F1G0J224A001	CAPACITOR, 6.3V, 0.22µF	1
C 1115	F1J0J475A009	CAPACITOR, 6.3V, 4.7µF	1
C 1116	F1J0J106A024	CAPACITOR, 6.3V, 10µF	1
CN 1101	K1KA04BA0014	CONNECTOR	1
CN 1102	K1MN04B00078	CONNECTOR	1
IC 1101	C0EBE0000460	IC	1
IC 1102	C1DB00001350	IC	1
IC 1103	C0CBCAC00312	IC, REGULATOR	1
Q 1101	XP0431400L	TRANSISTOR	2
Q 1102			
Q 1103	UNR9113J0L	TRANSISTOR	1
R 1101	ERJ2GEJ473X	RESISTOR, 1/16W, 47KΩ	1
R 1104	ERJ2GEJ102X	RESISTOR, 1/16W, 1KΩ	12
R 1106			

R 1108			
R 1110			
R 1111			
R 1112			
R 1113			
R 1118			
R 1120			
R 1121			
R 1122			
R 1123			
R 1109	ERJ2GEJ273X	RESISTOR, 1/16W, 27K Ω	1
R 1114	ERJ2GEJ822X	RESISTOR, 1/16W, 8.2K Ω	4
R 1115			
R 1116			
R 1117			
R 1119	ERJ2GE0R00X	RESISTOR, 1/16W, 0 Ω	2
R 1129			
R 1124	DEARA8AJ473M	RESISTOR ARRAY	1
R 1125	ERJ2GEJ270X	RESISTOR, 1/16W, 27 Ω	2
R 1126			
R 1127	ERJ2GEJ152X	RESISTOR, 1/16W, 1.5K Ω	1
X 1101	H2D600400005	OSCILLATOR, 6MHz	1

CF-T4

Schematic Diagram

Main 1 DOTHAN HOST BUS

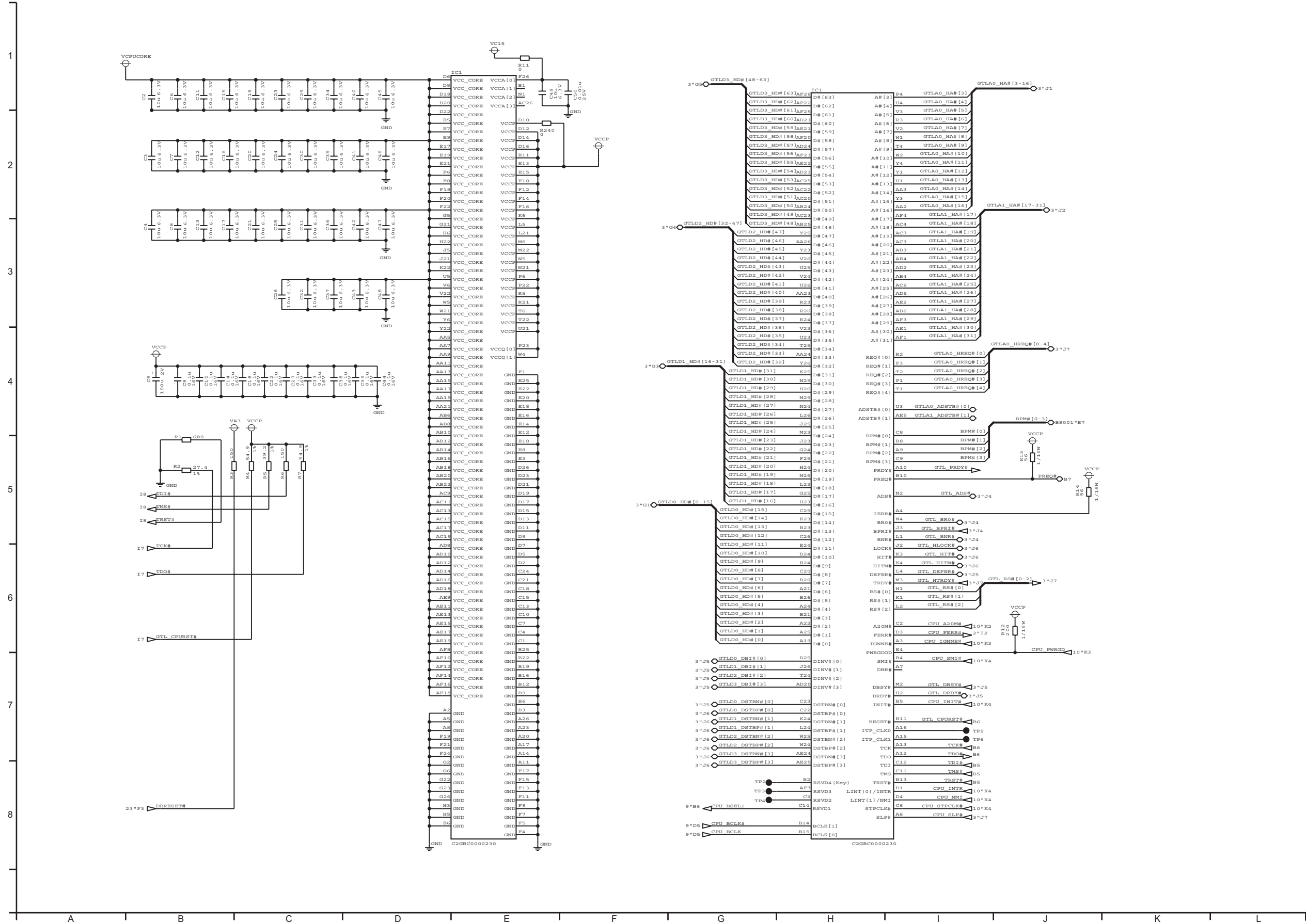

Main 2 DOTHAN POWER

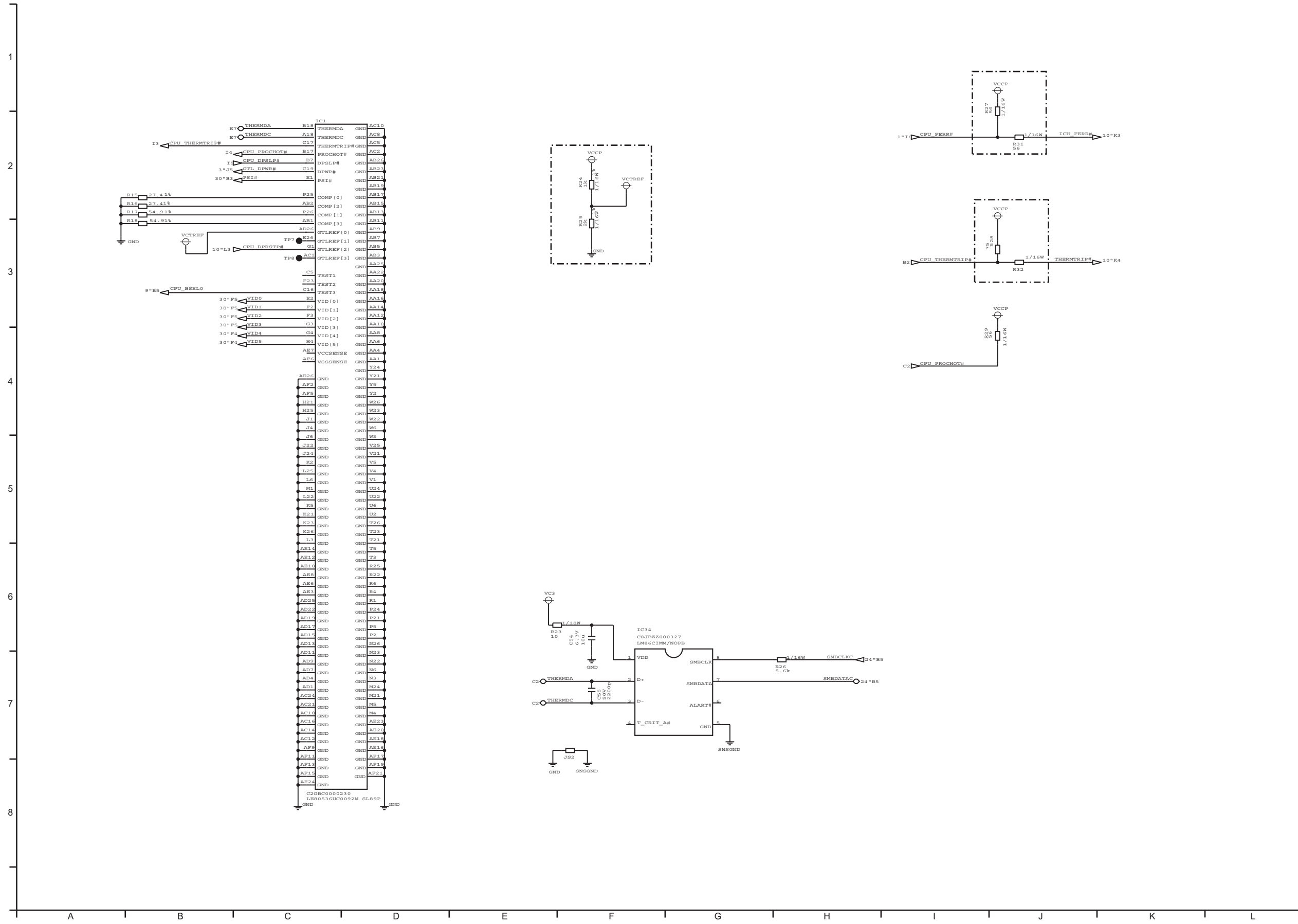

Main 3 Alviso - GMS SM, HOST

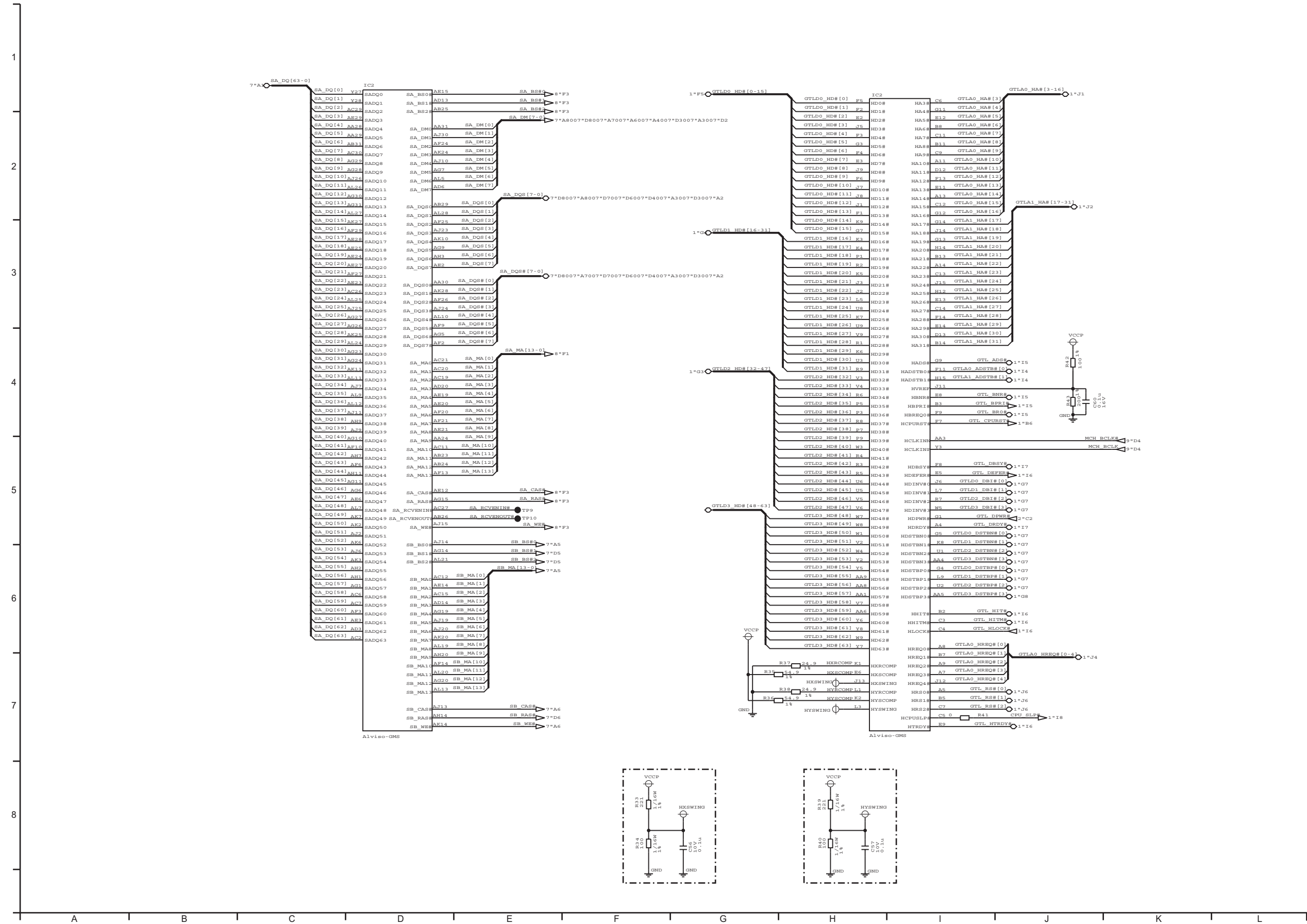

Main 4 Alviso - GMS DMI, LVDS

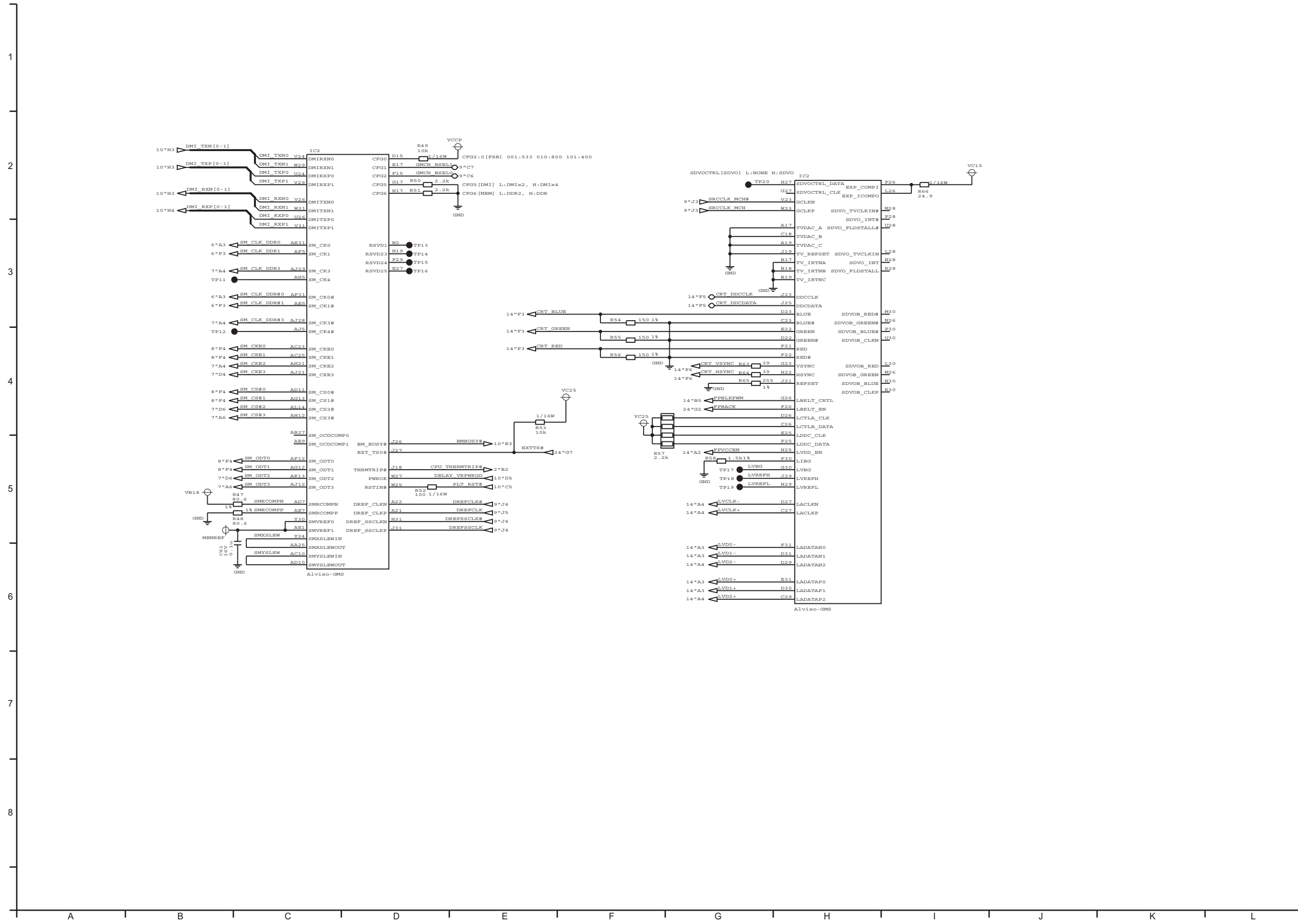

Main 5 Alviso - GMS POWER

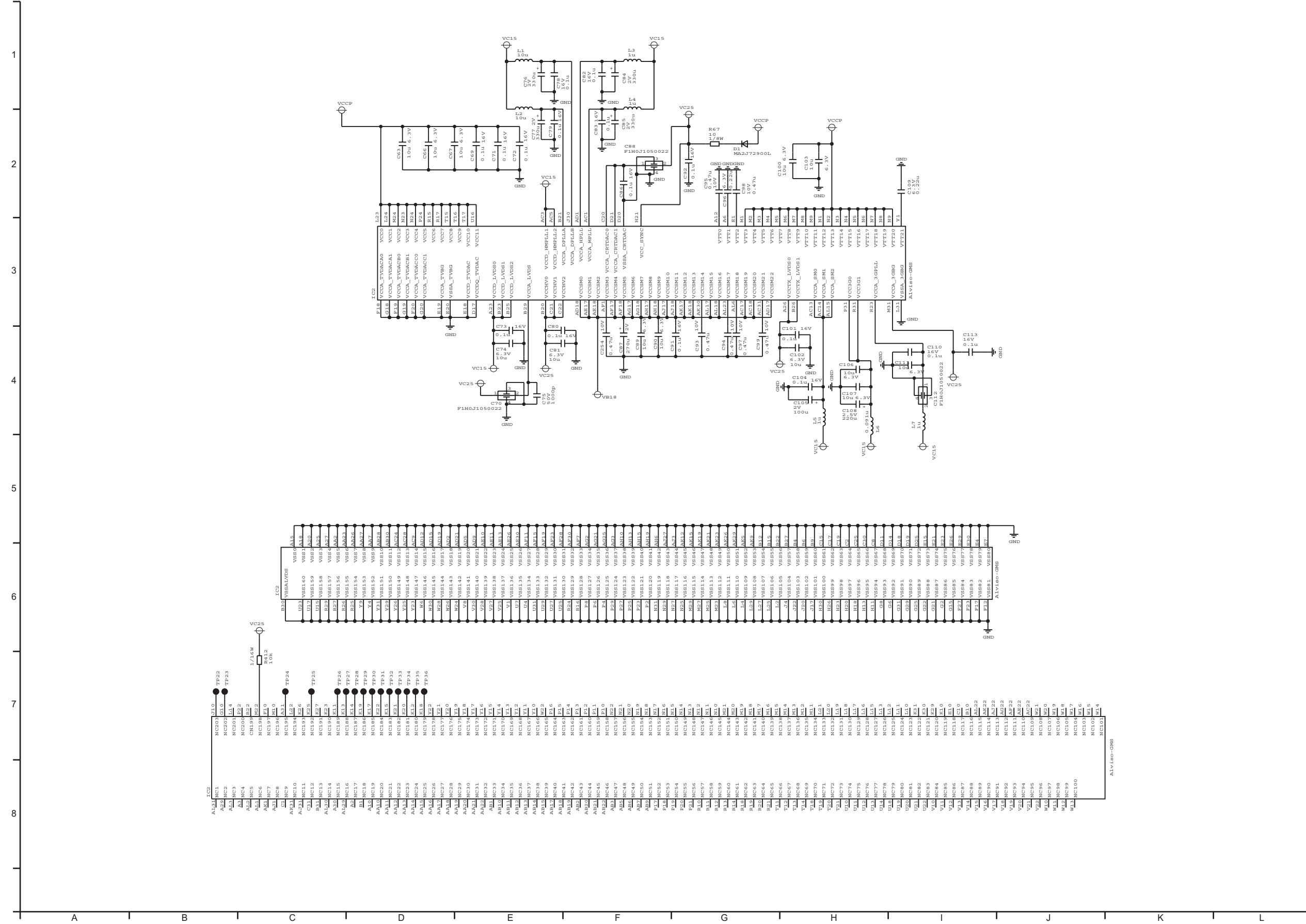

Main 6 ON BOARD MEMORY BANK 0/1

BANK 0/1 (ON BOARD)

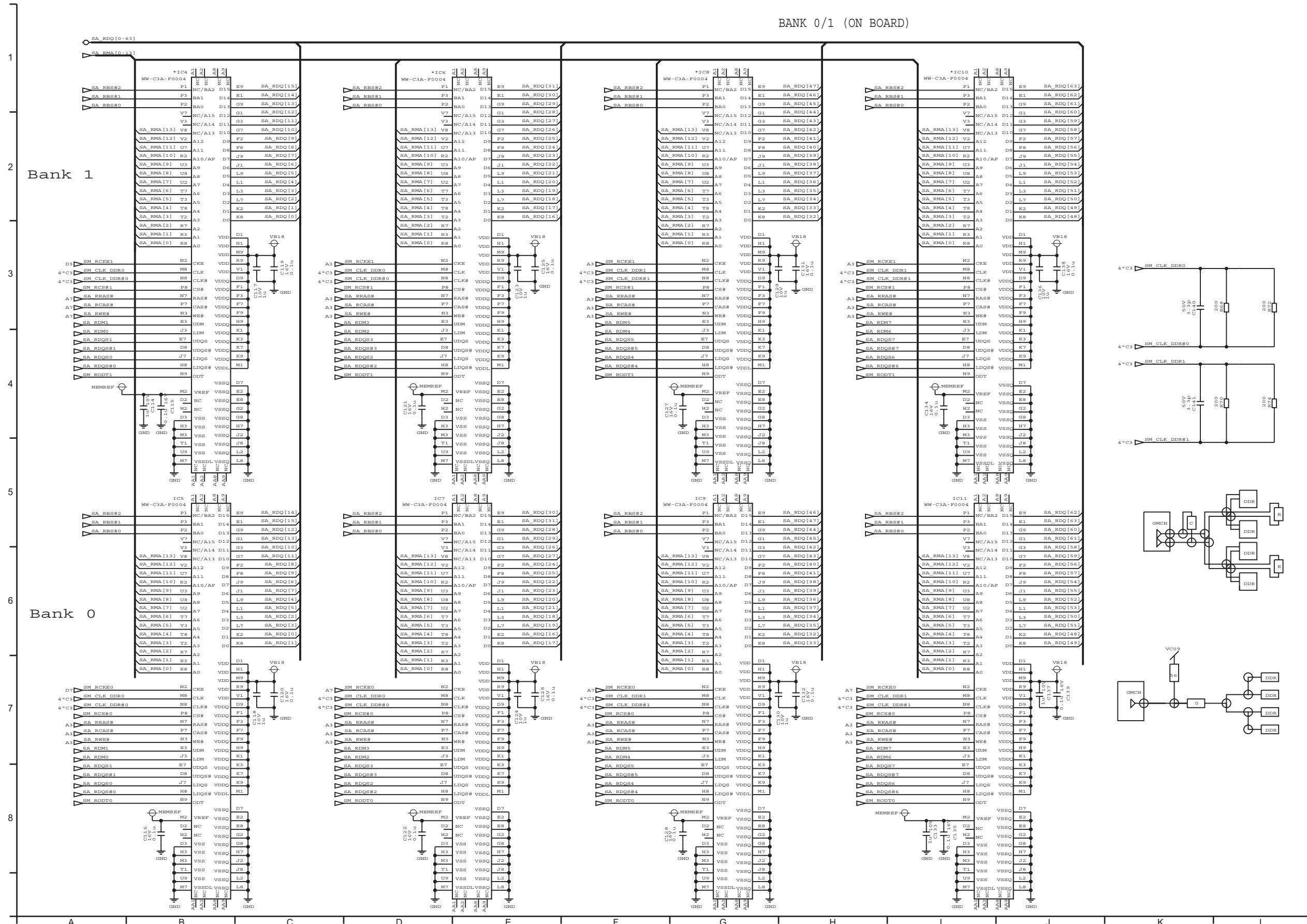

Main 7 Micro - DIMM Bank 2/3

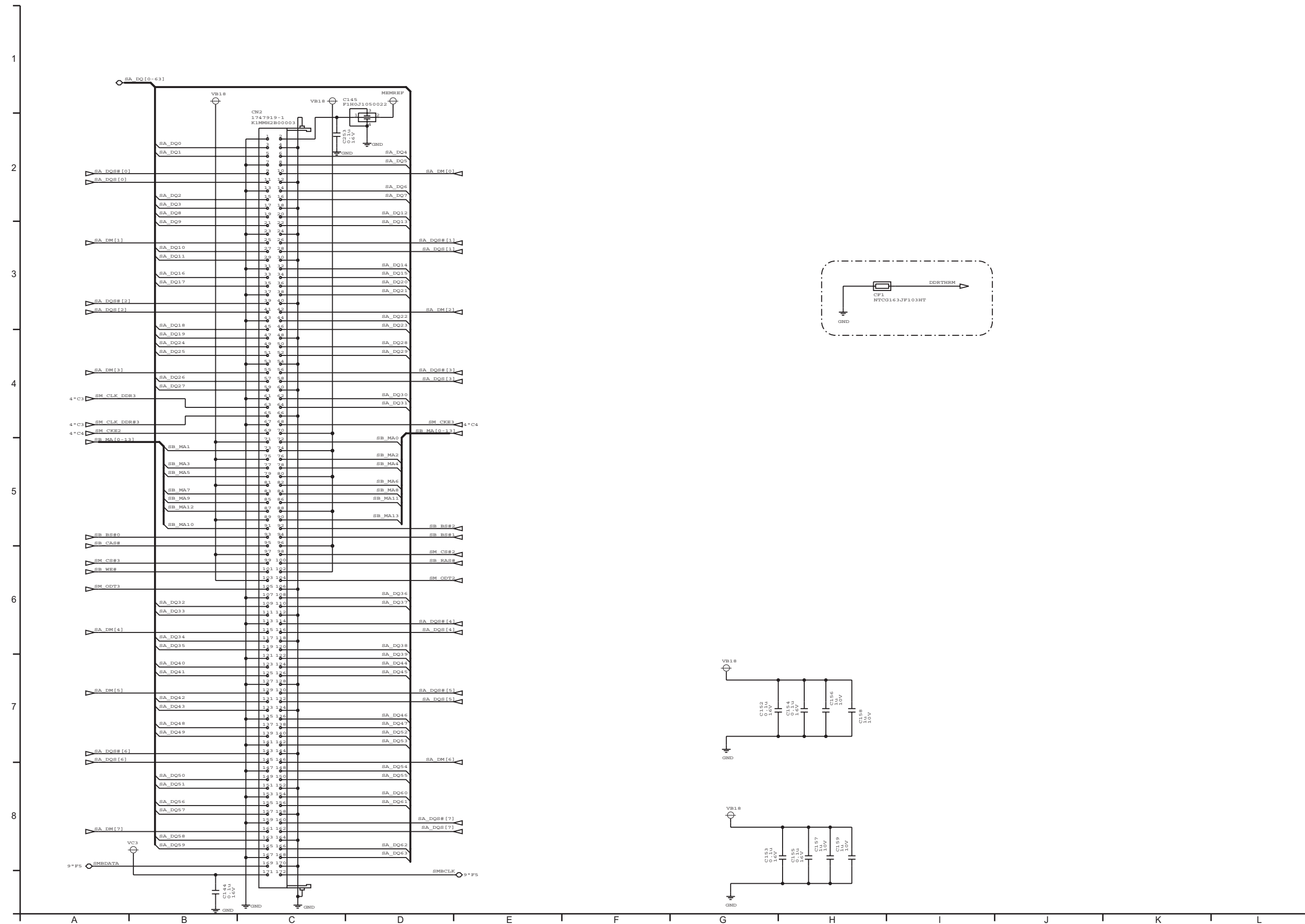

Main 8 DDR2 TERM

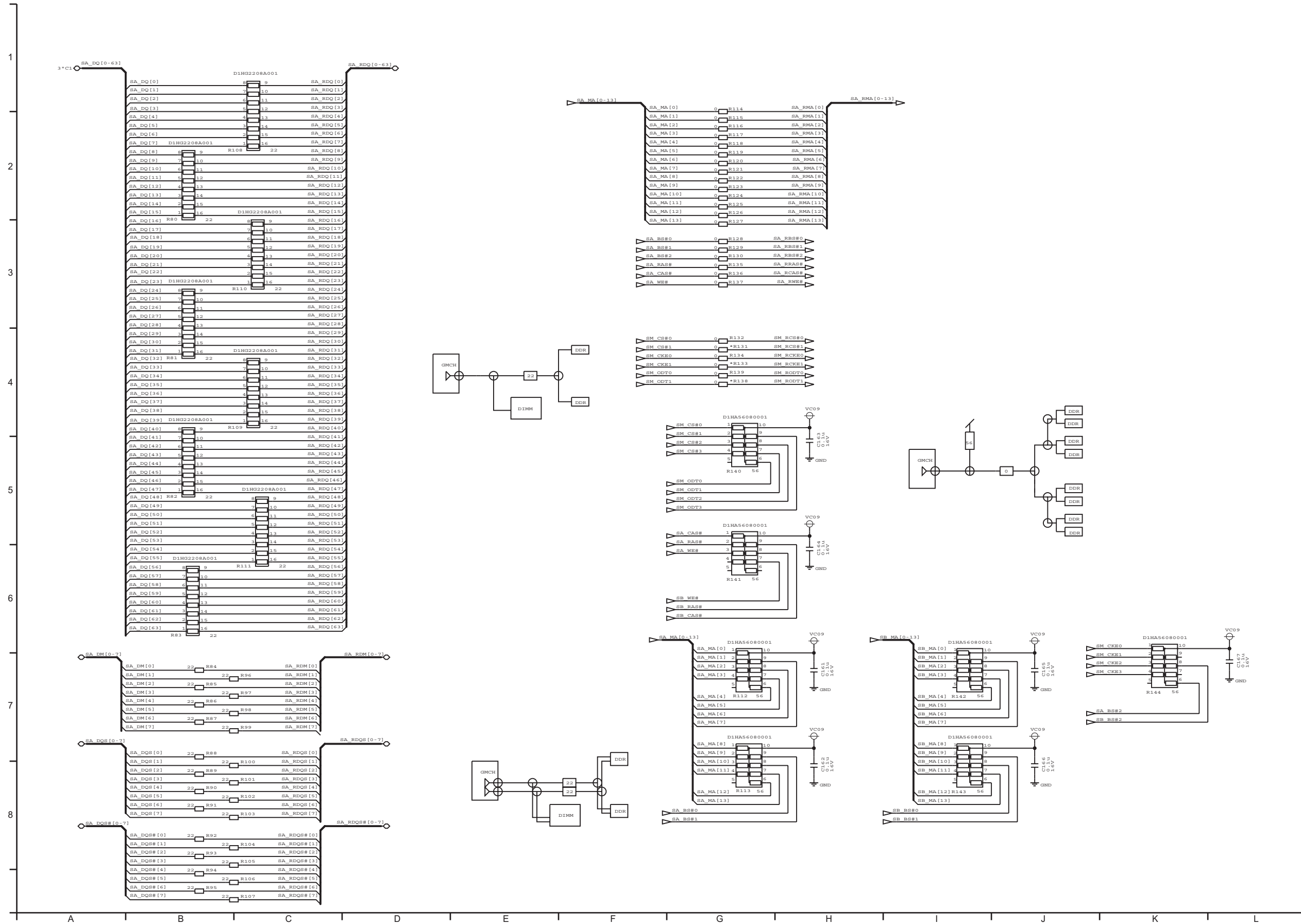

Main 9 CLOCK GENERATER

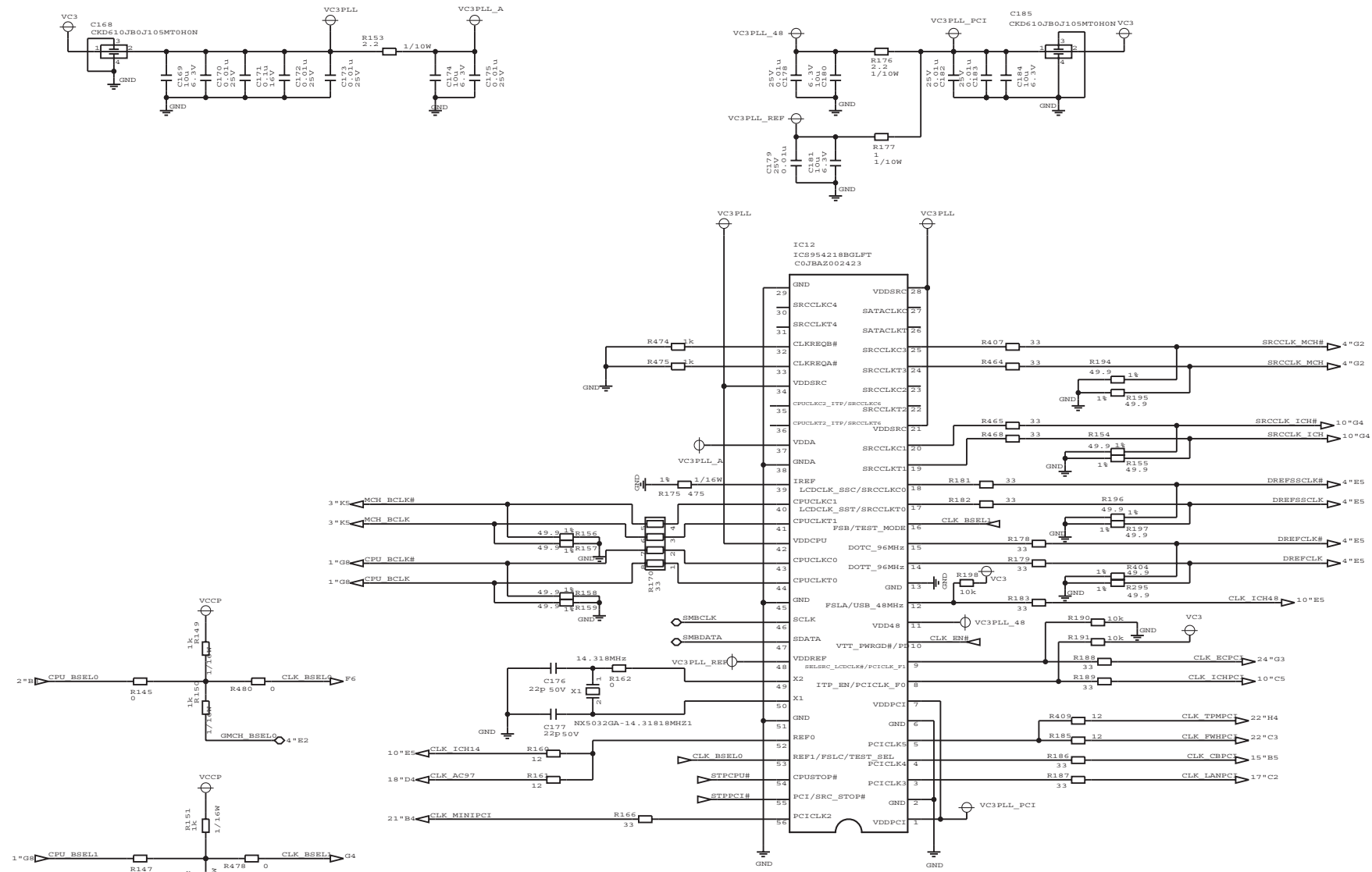

Main 10 ICH6 - M

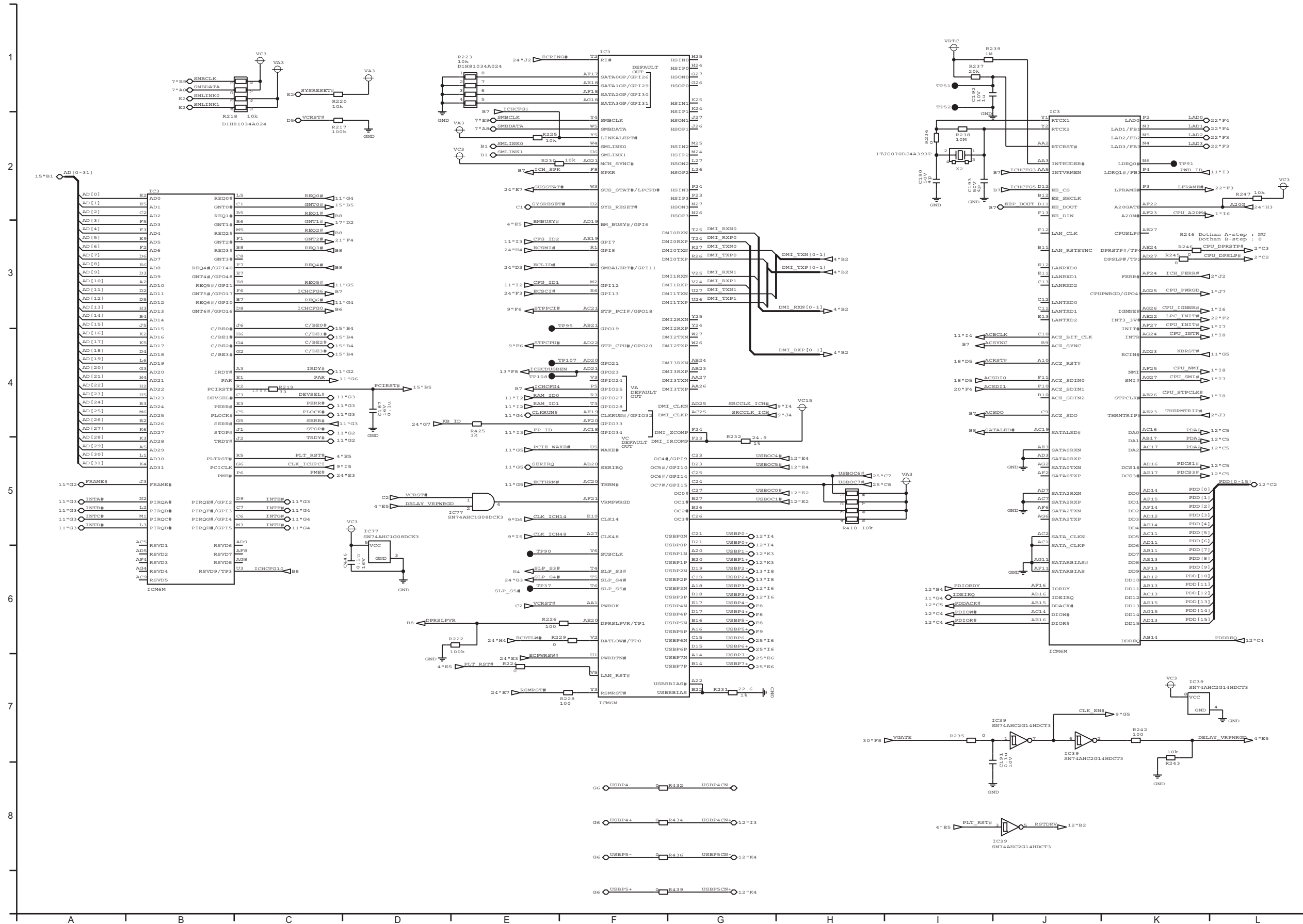

Main 11 ICH6 - M POWER

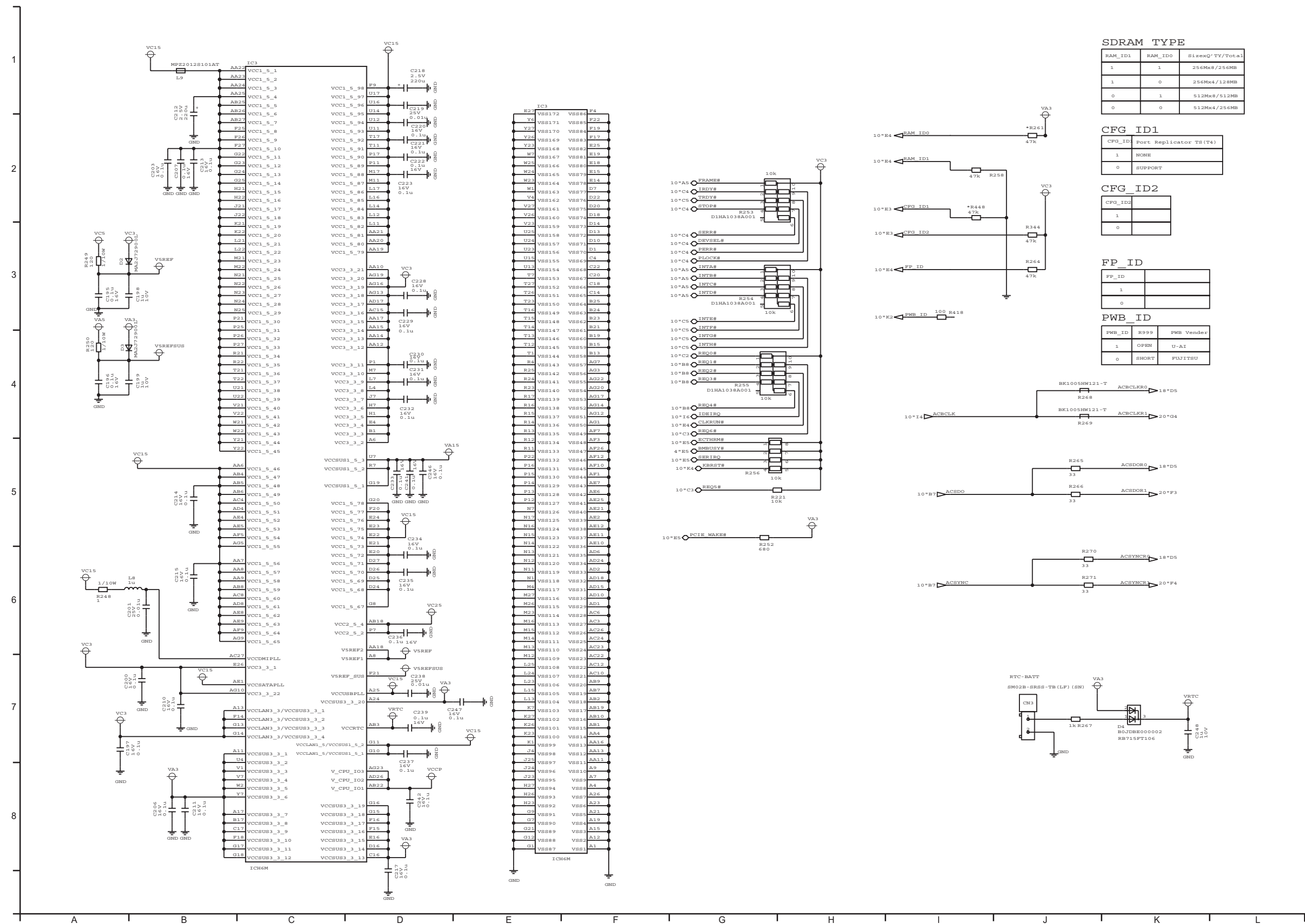

SDRAM TYPE

RAM_ID1	RAM_ID0	SizeQ'TY/Total
1	1	256Mb8/256Mb
1	0	256Mb4/128Mb
0	1	512Mb8/512Mb
0	0	512Mb4/256Mb

CFG_ID1

CFG_ID1	Port Replicator TS (T4)
1	NONE
0	SUPPORT

CFG_ID2

CFG_ID2	
1	
0	

FP_ID

FP_ID	
1	
0	

PWB_ID

PWB_ID	R999	PWB Vendor
1	OPEN	U-A1
0	SHORT	PUJITSU

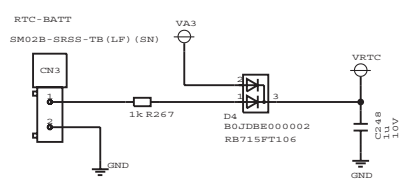
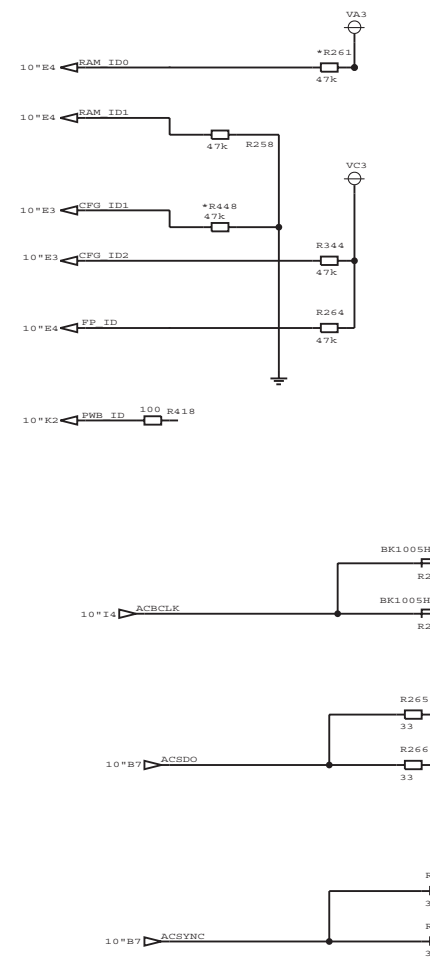

Main 12 HDD, USB, TS & BT CN

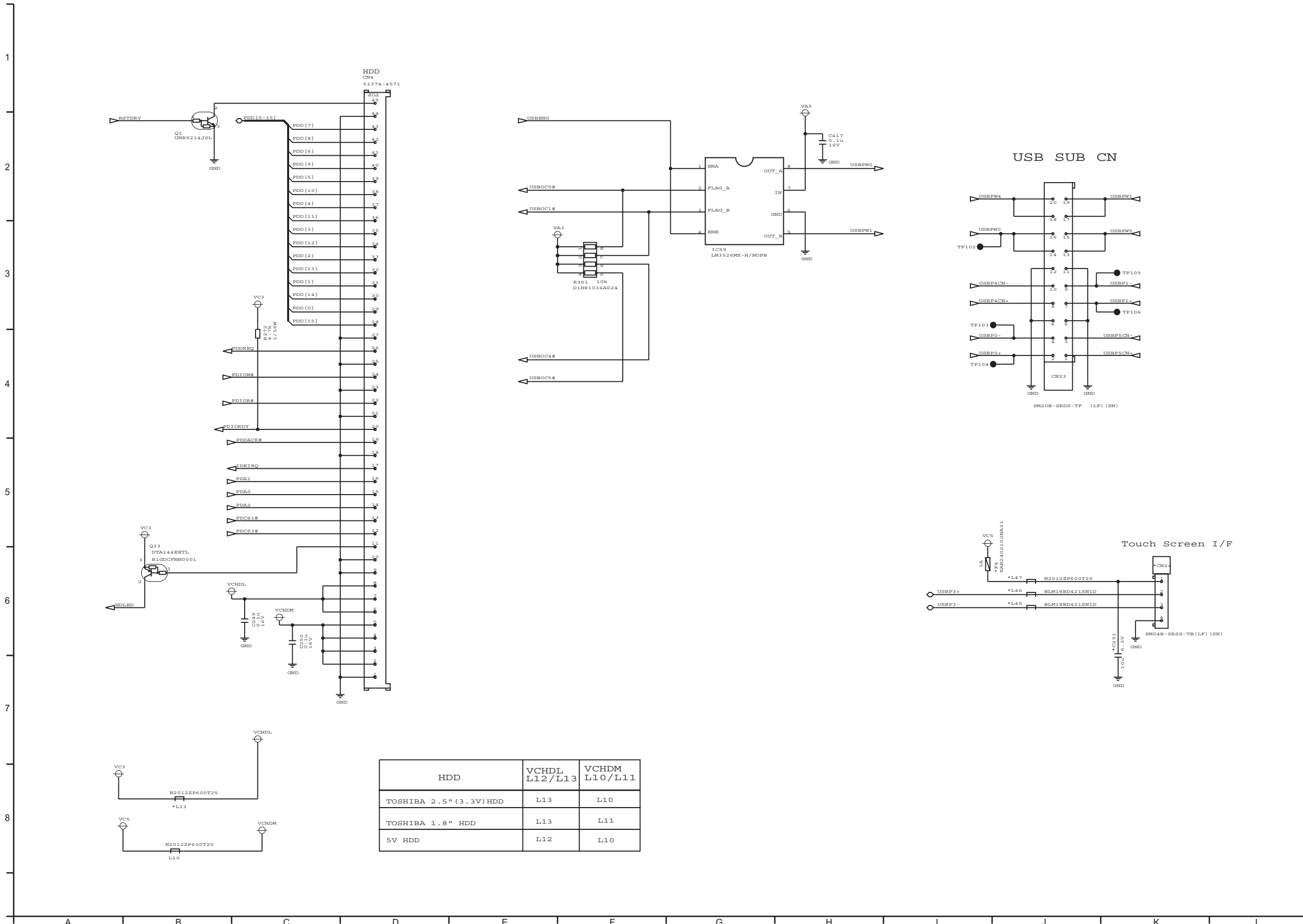

HDD	VCHDL L12/L13	VCHDM L10/L11
TOSHIBA 2.5" (3.3V)HDD	L13	L10
TOSHIBA 1.8" HDD	L13	L11
5V HDD	L12	L10

Main 13 BLANK

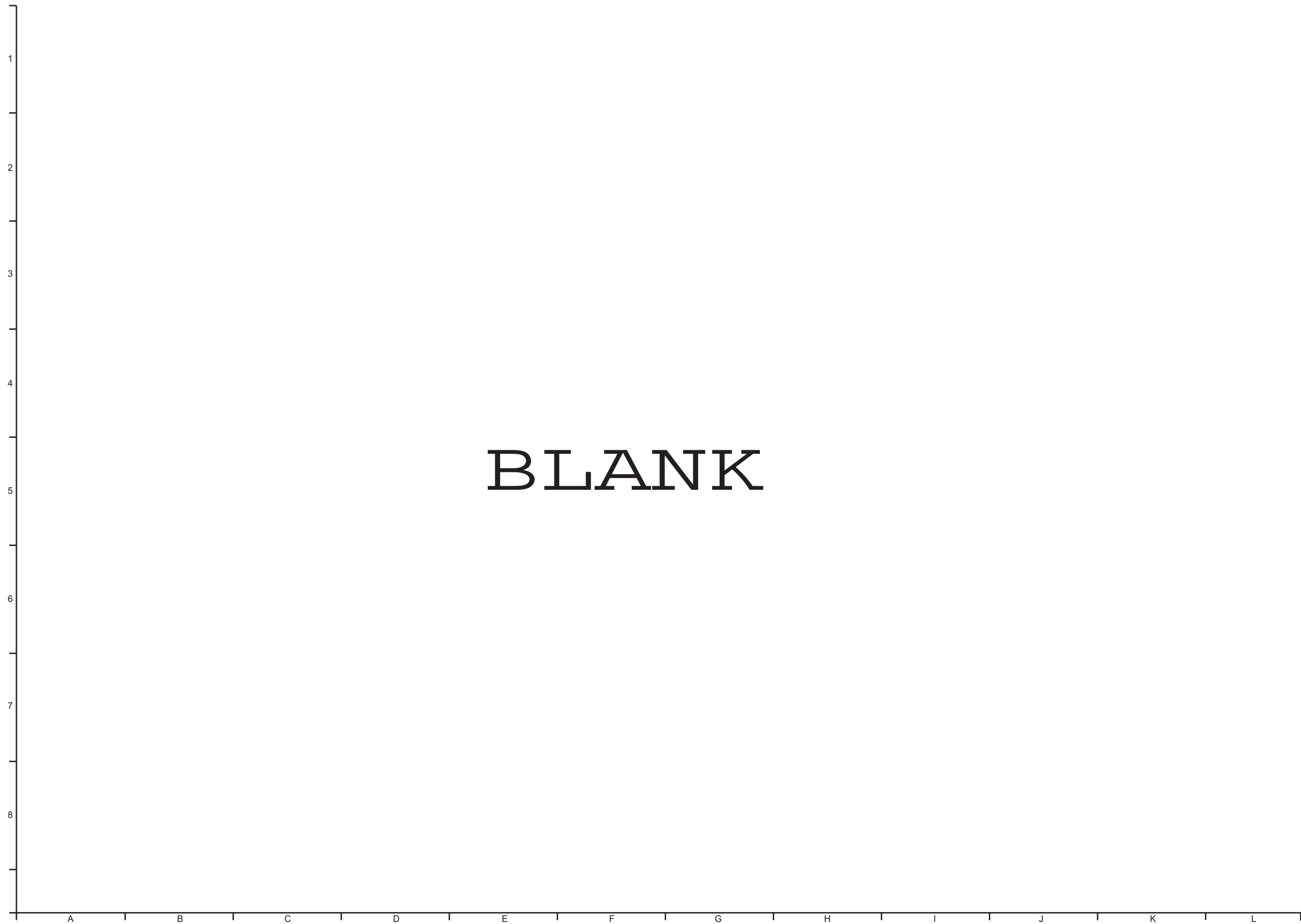

Main 14 LCD & CRT I/F

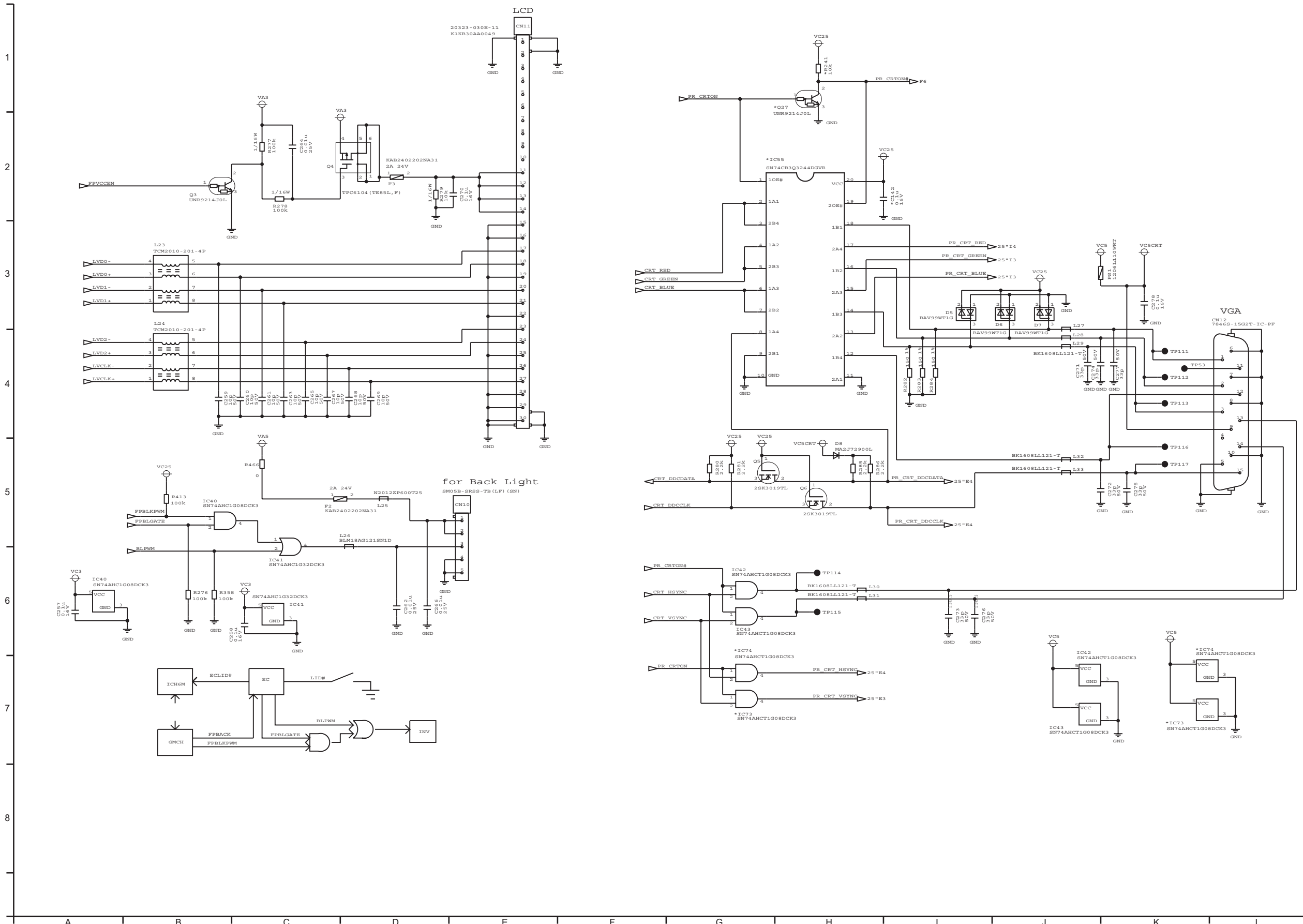

Main 15 CARD BUS CONTROLLER

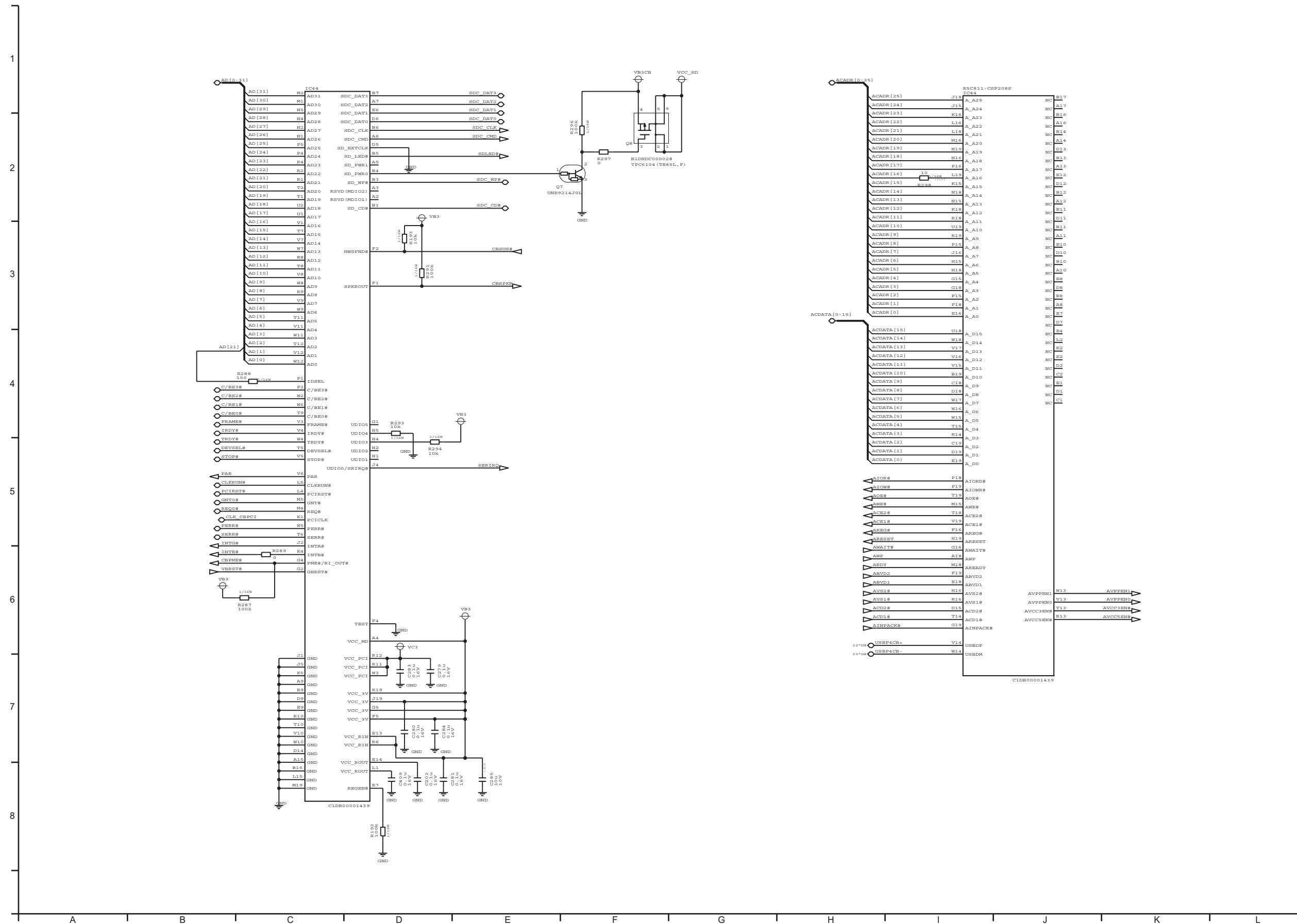

Main 16 CB & SD SLOT CN

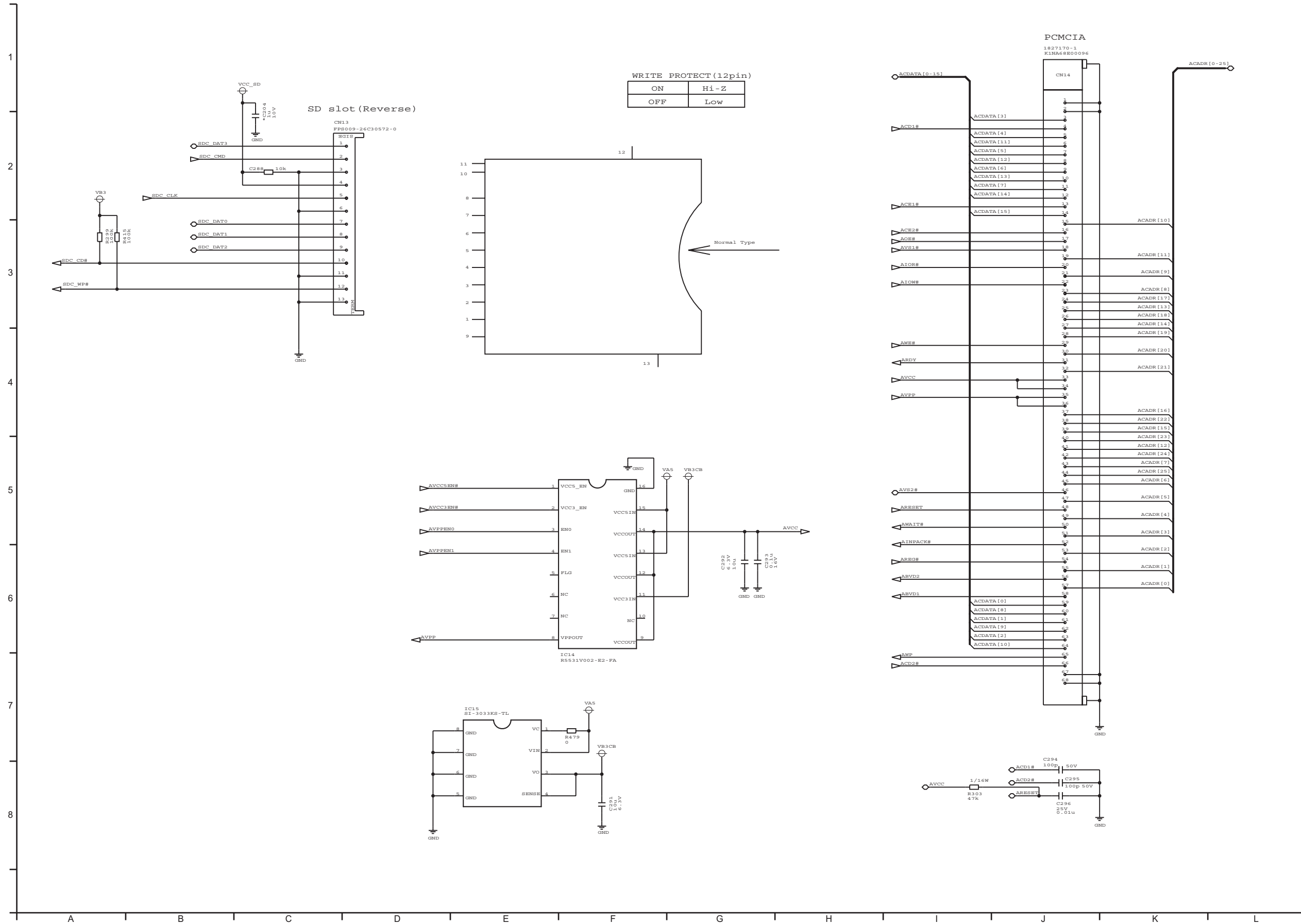

Main 17 LAN

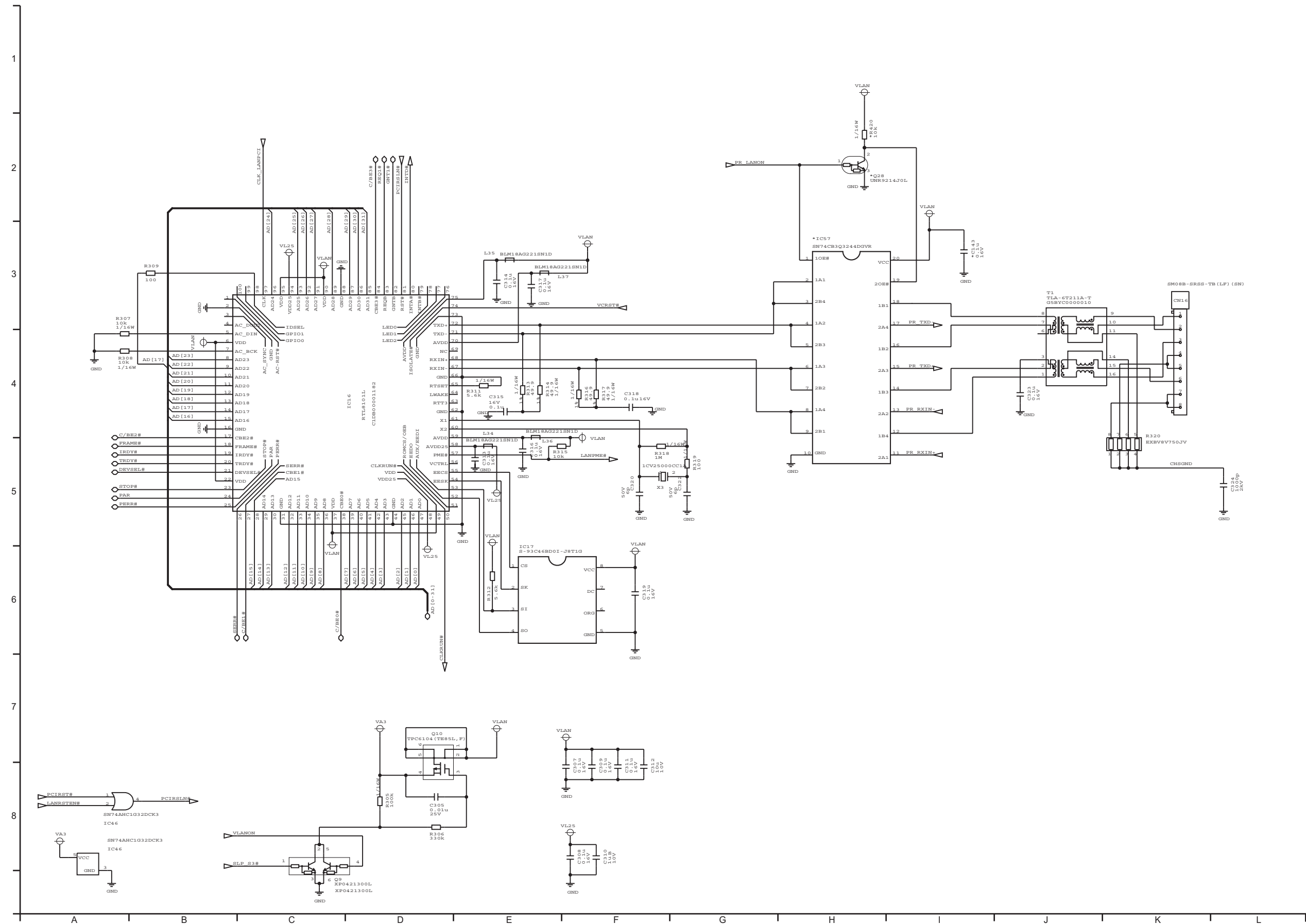

Main 18 AC97 CODEC

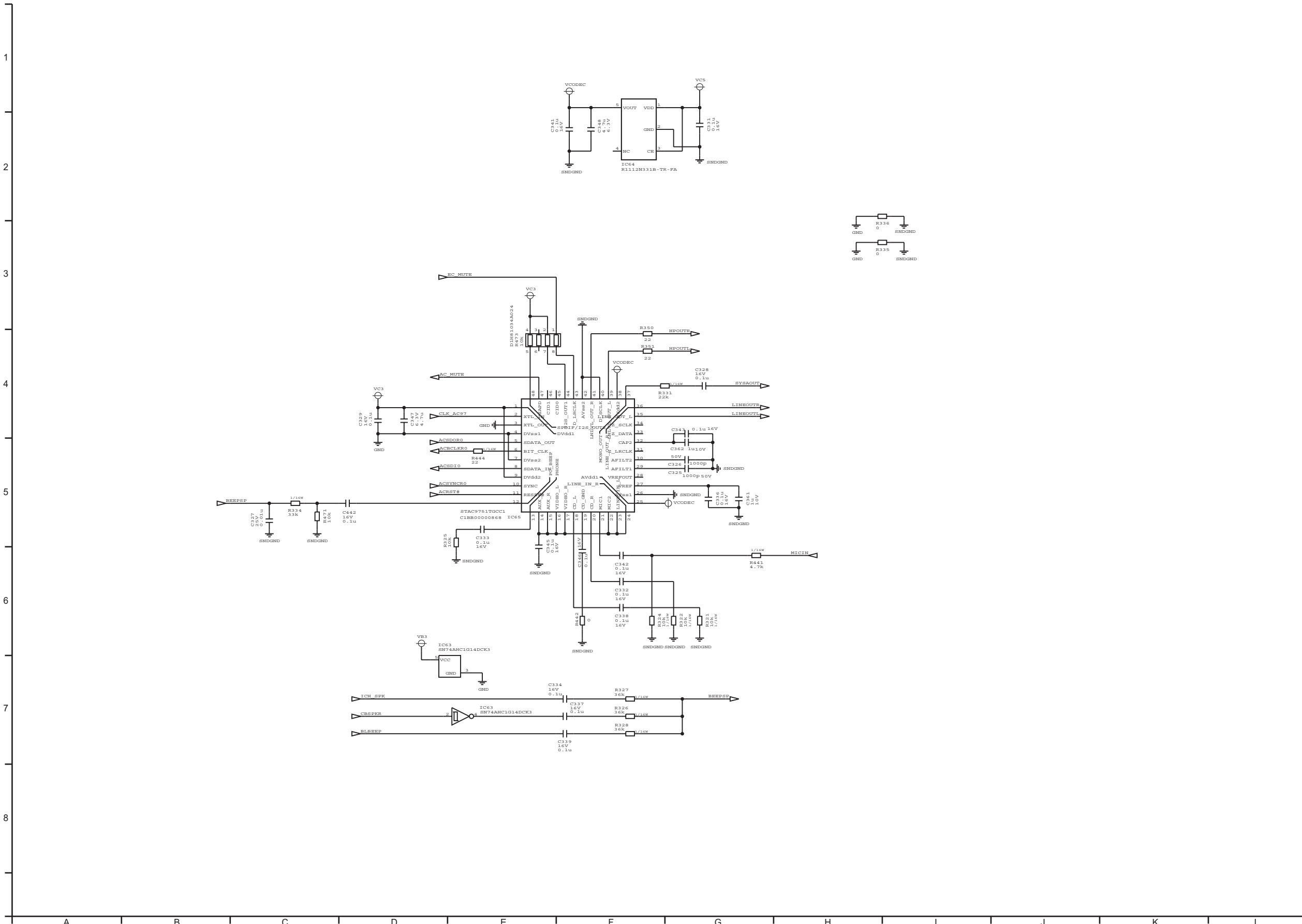

Main 19 AUDIO AMP, MIC

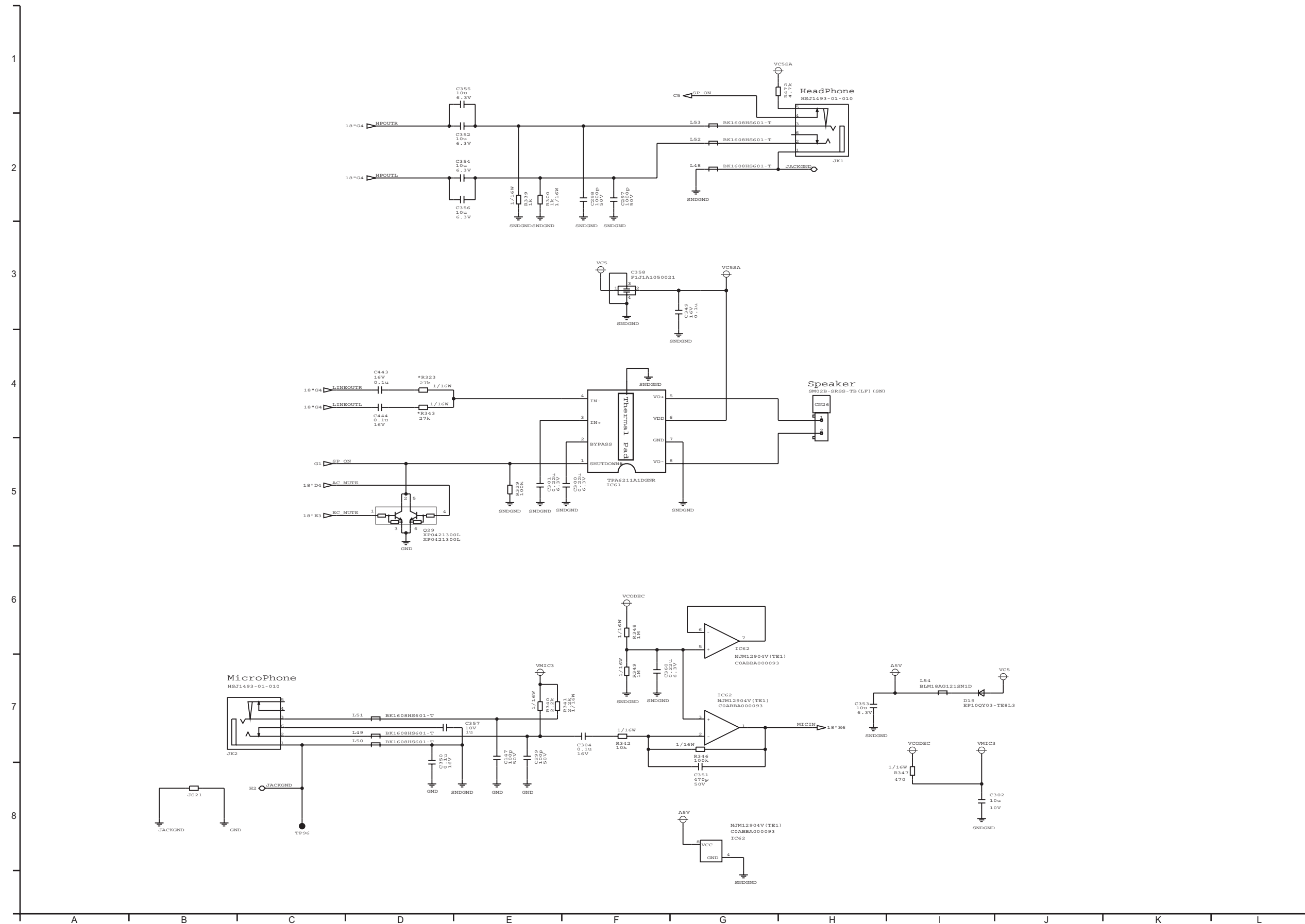

Main 20 MDC

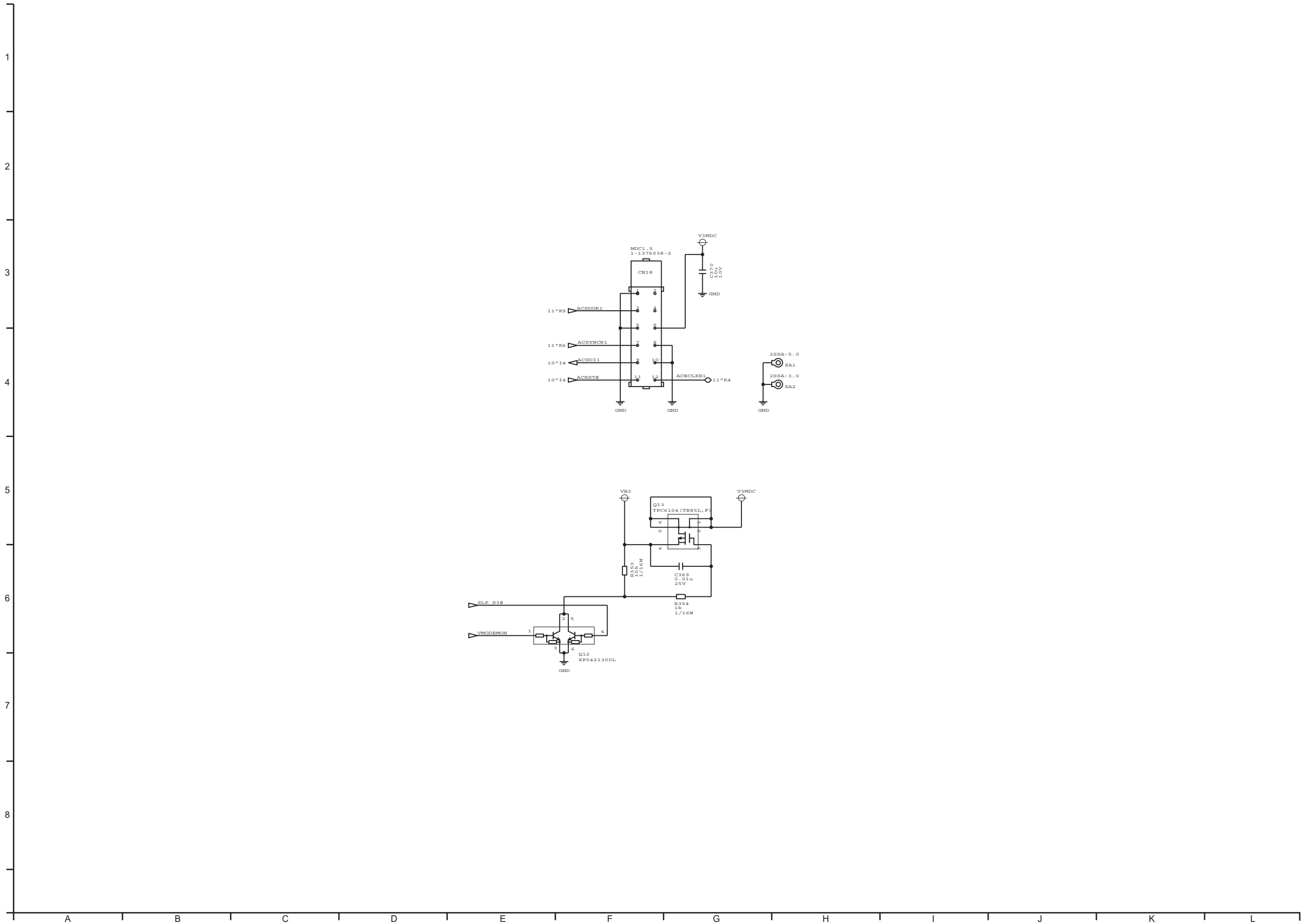

Main 21 MINI - PCI

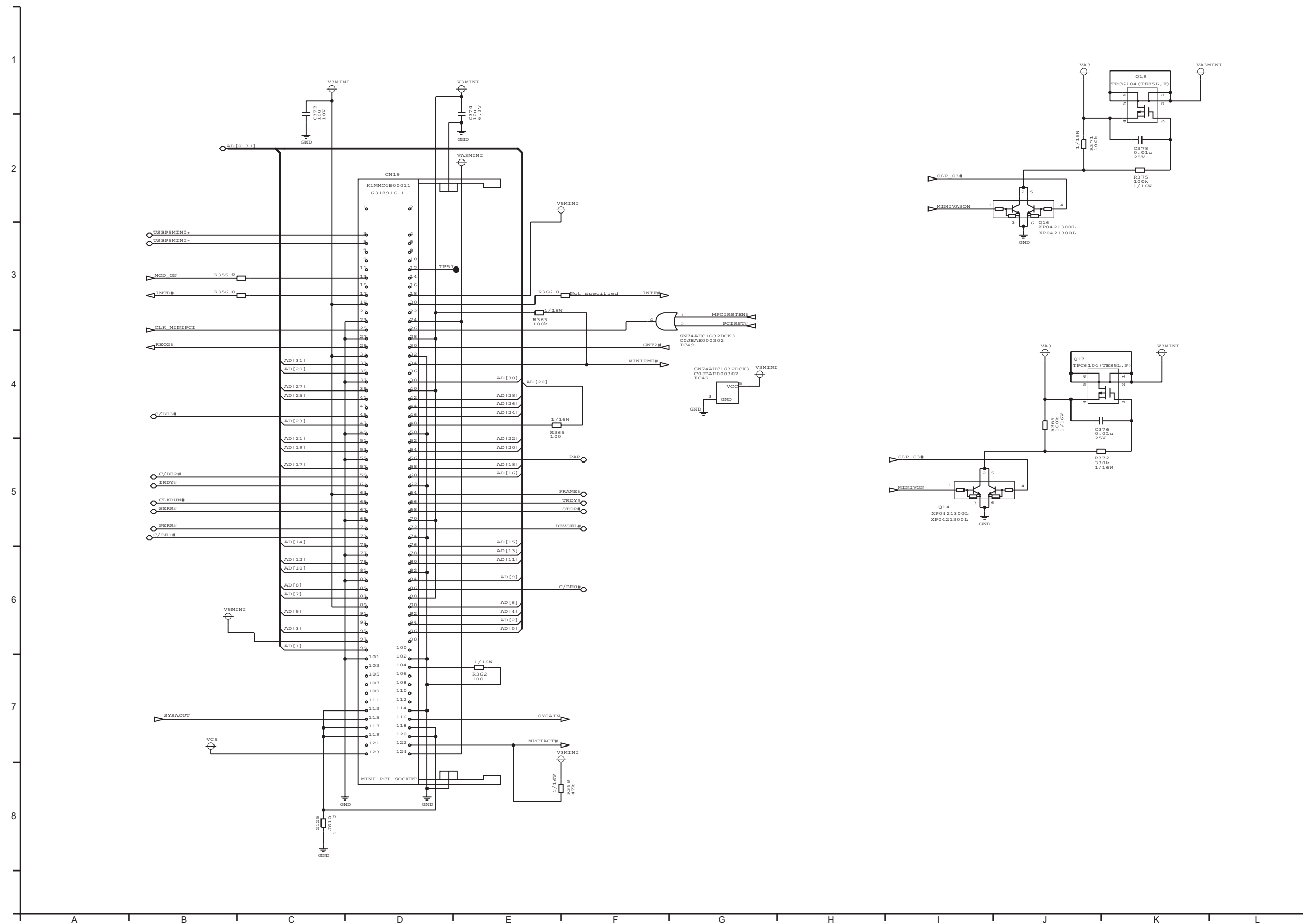

Main 22 BIOS, TPM

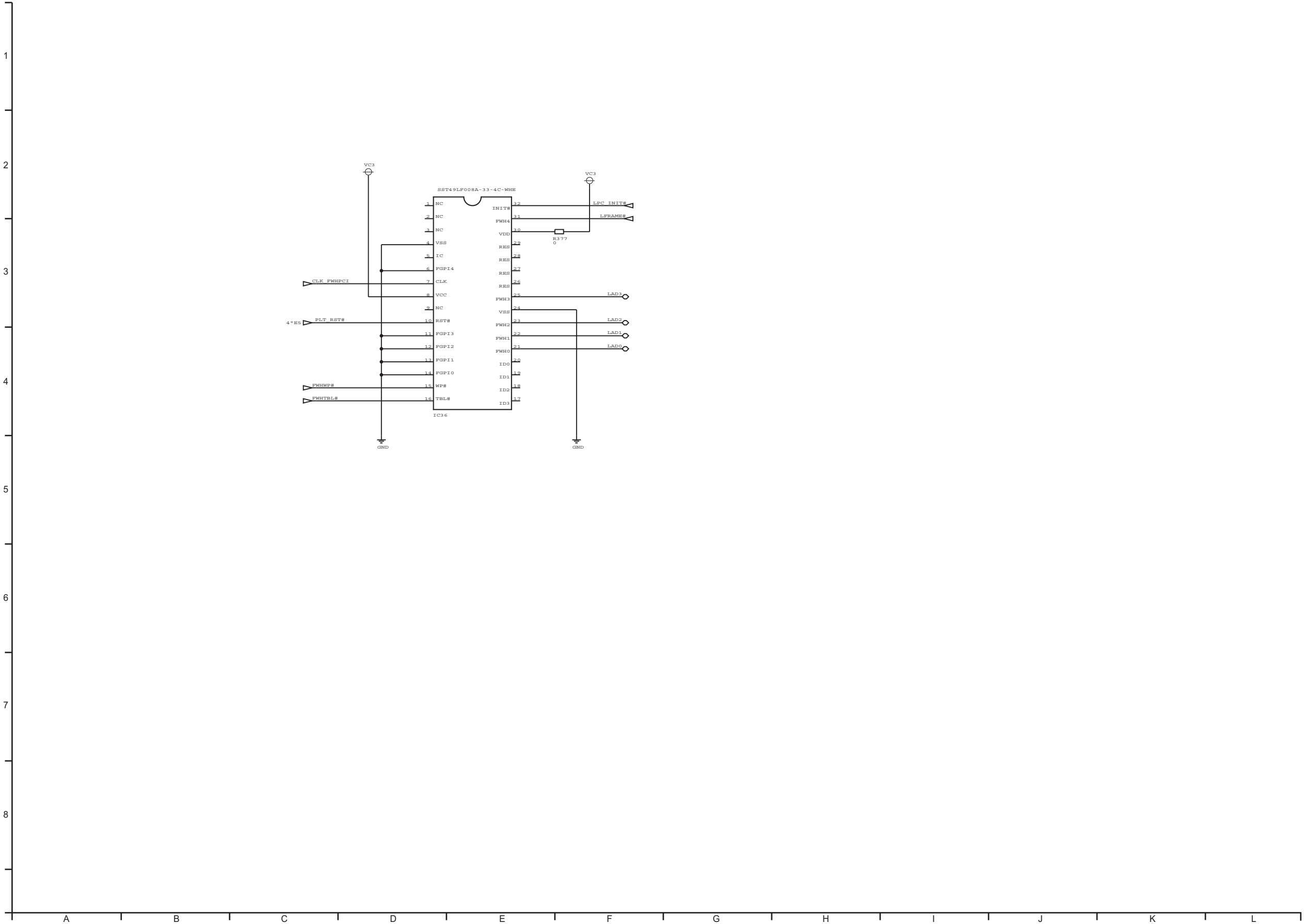

Main 23 RESET

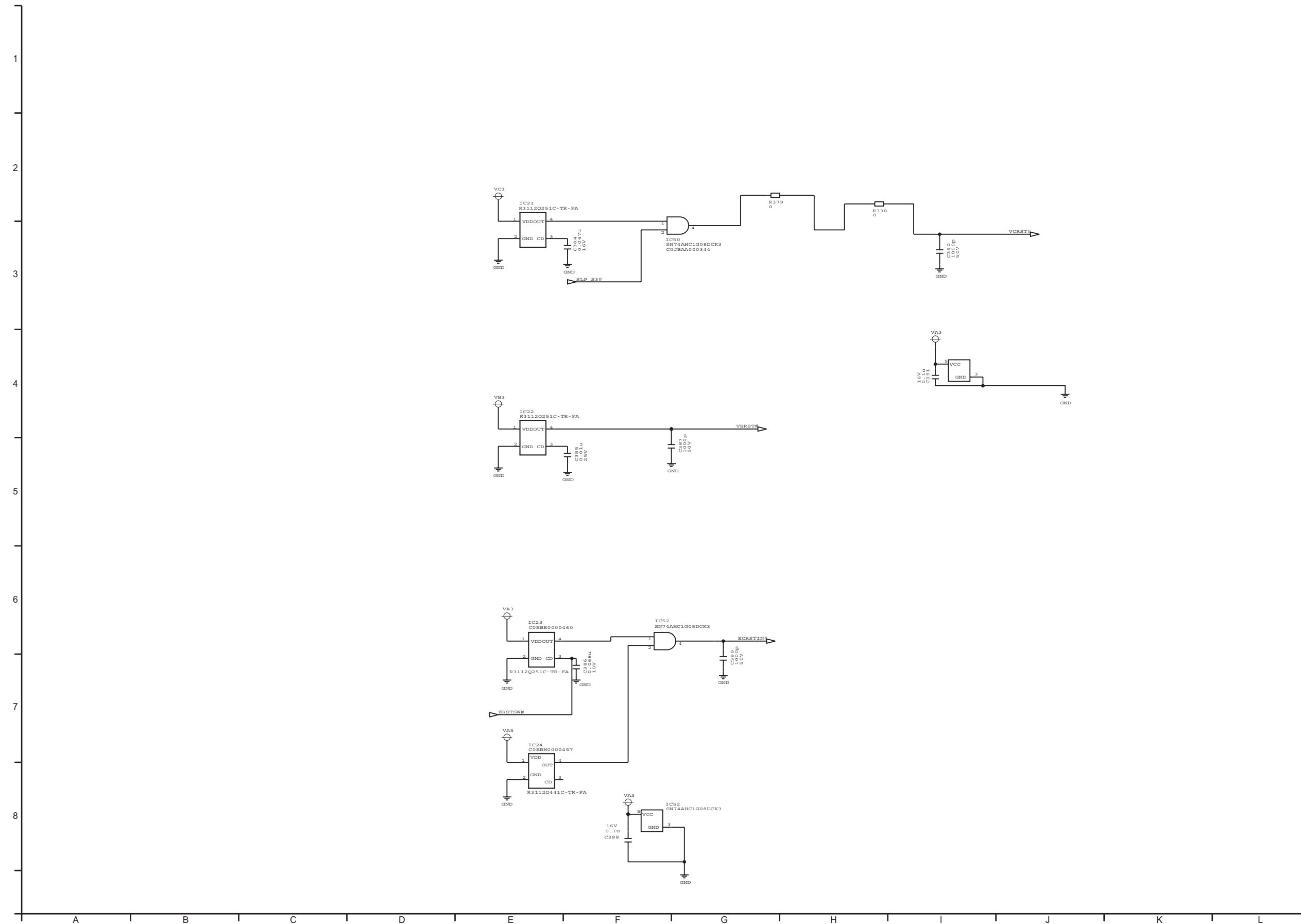

Main 24 EC & KBC

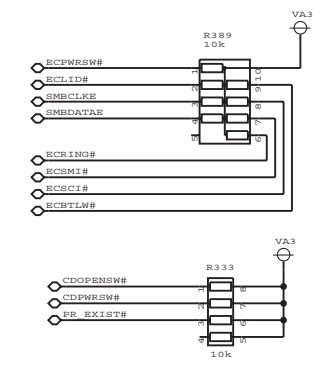
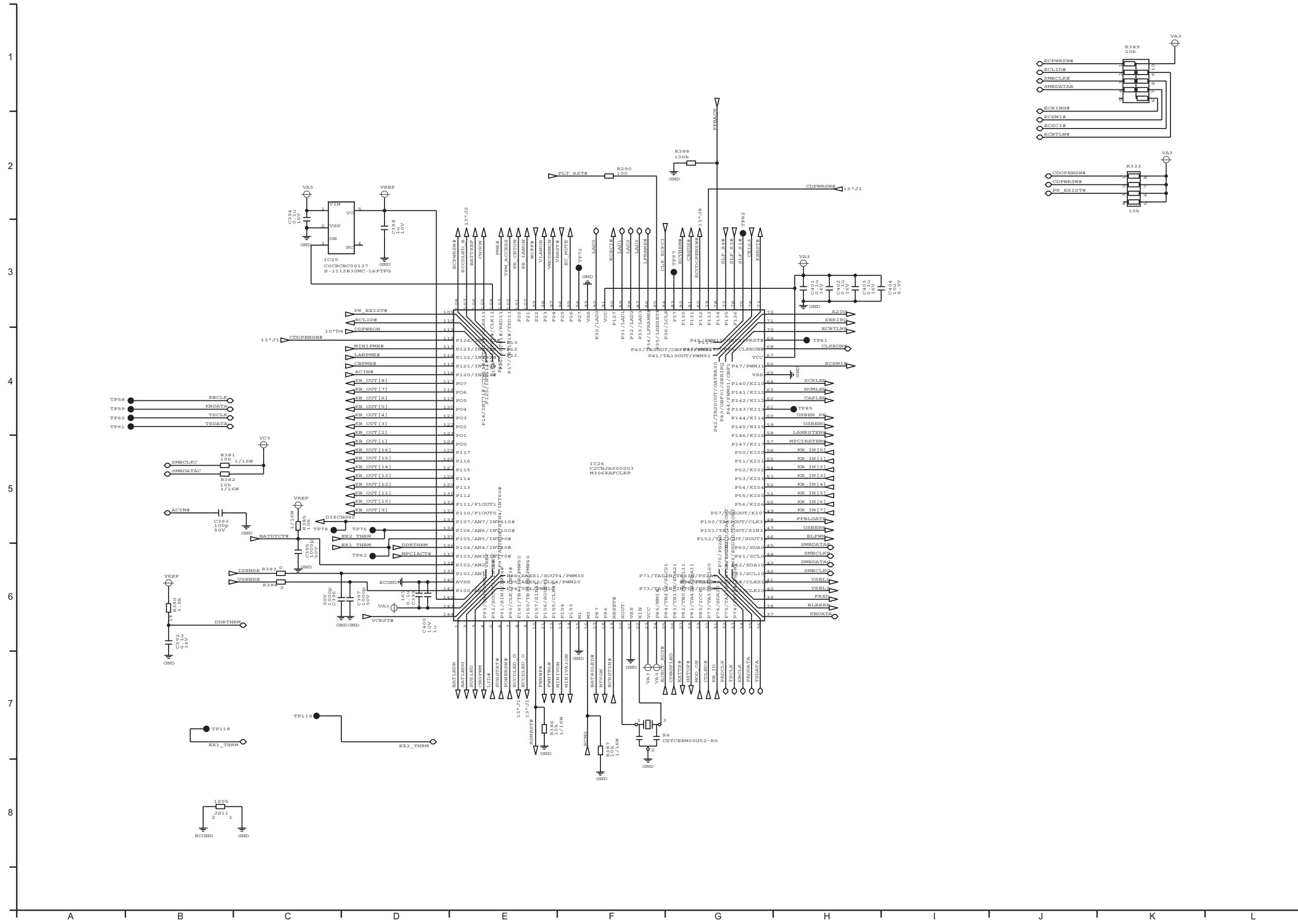

Main 25 I / O CN

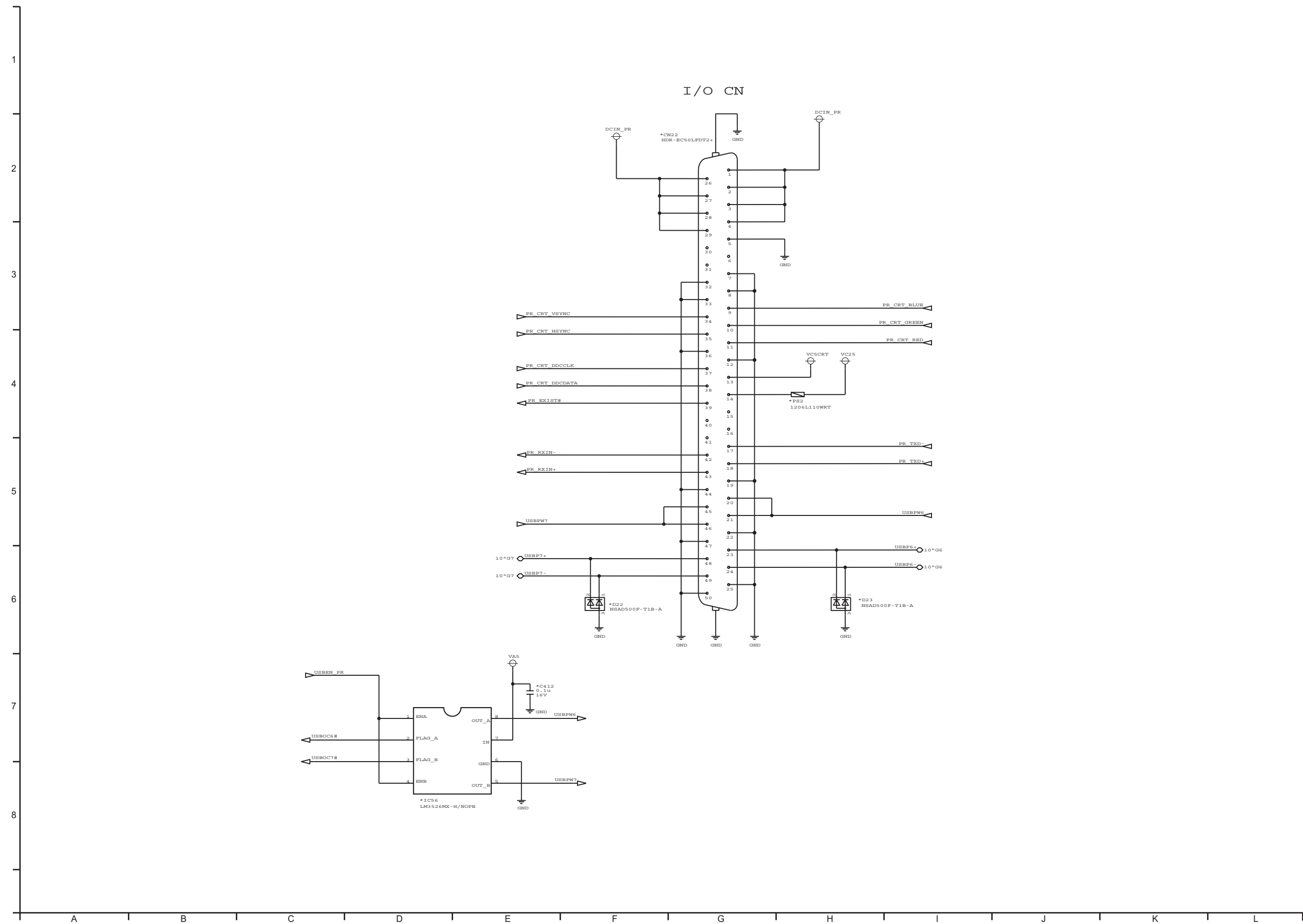

Main 26 KBD, PAD, SW & LED

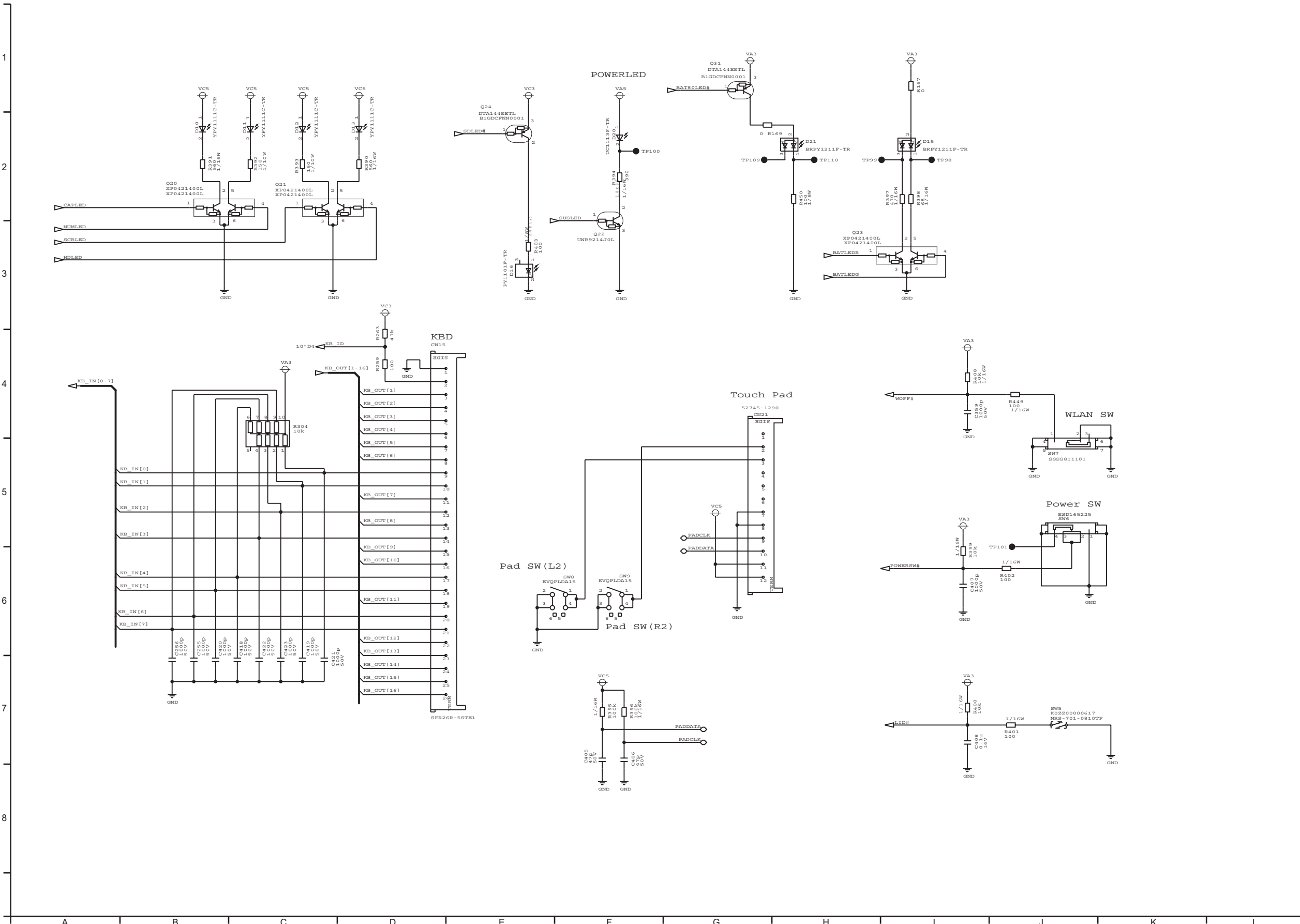

Main 27 DC IN & BATTERY

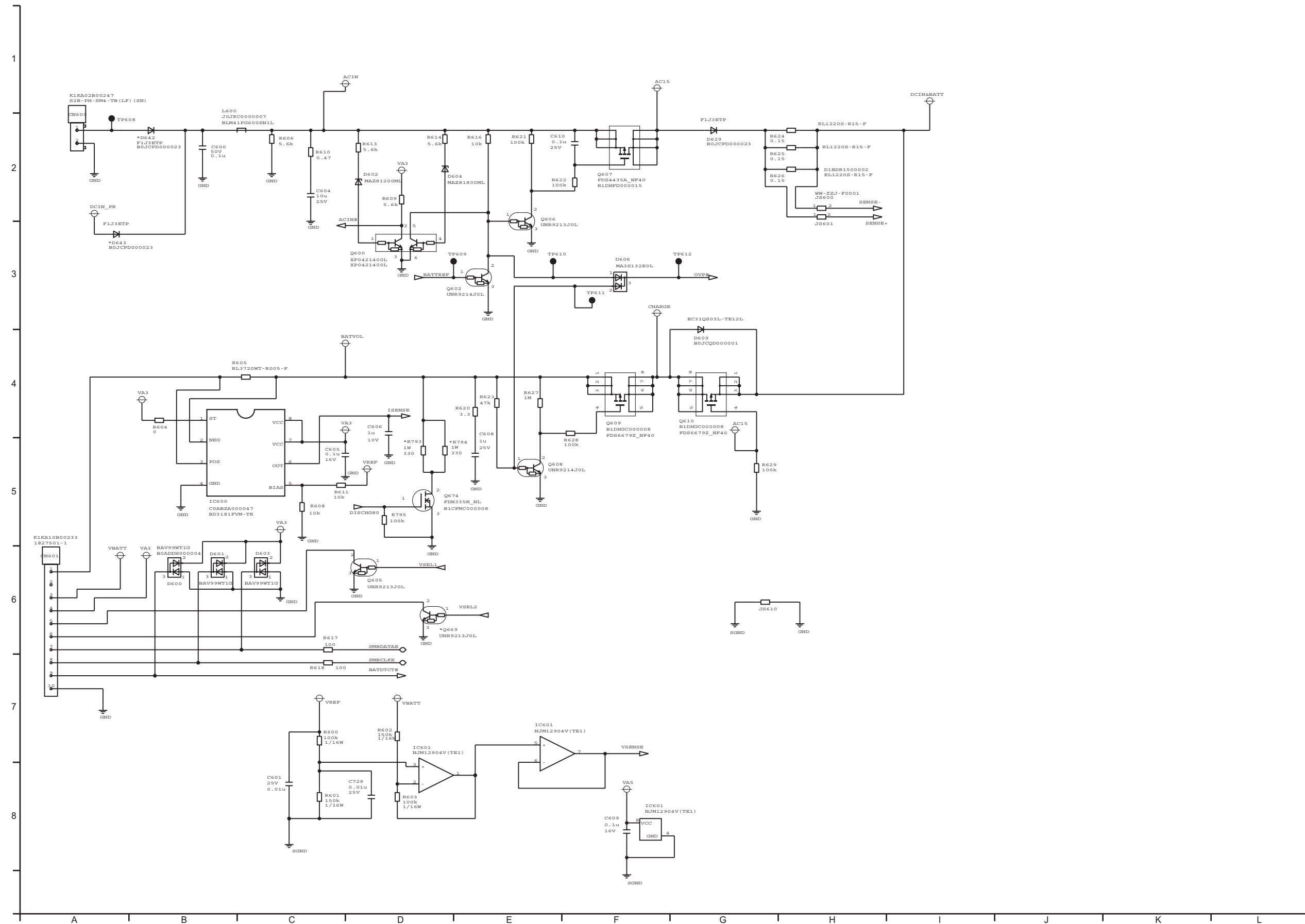

Main 28 VA3, VA5

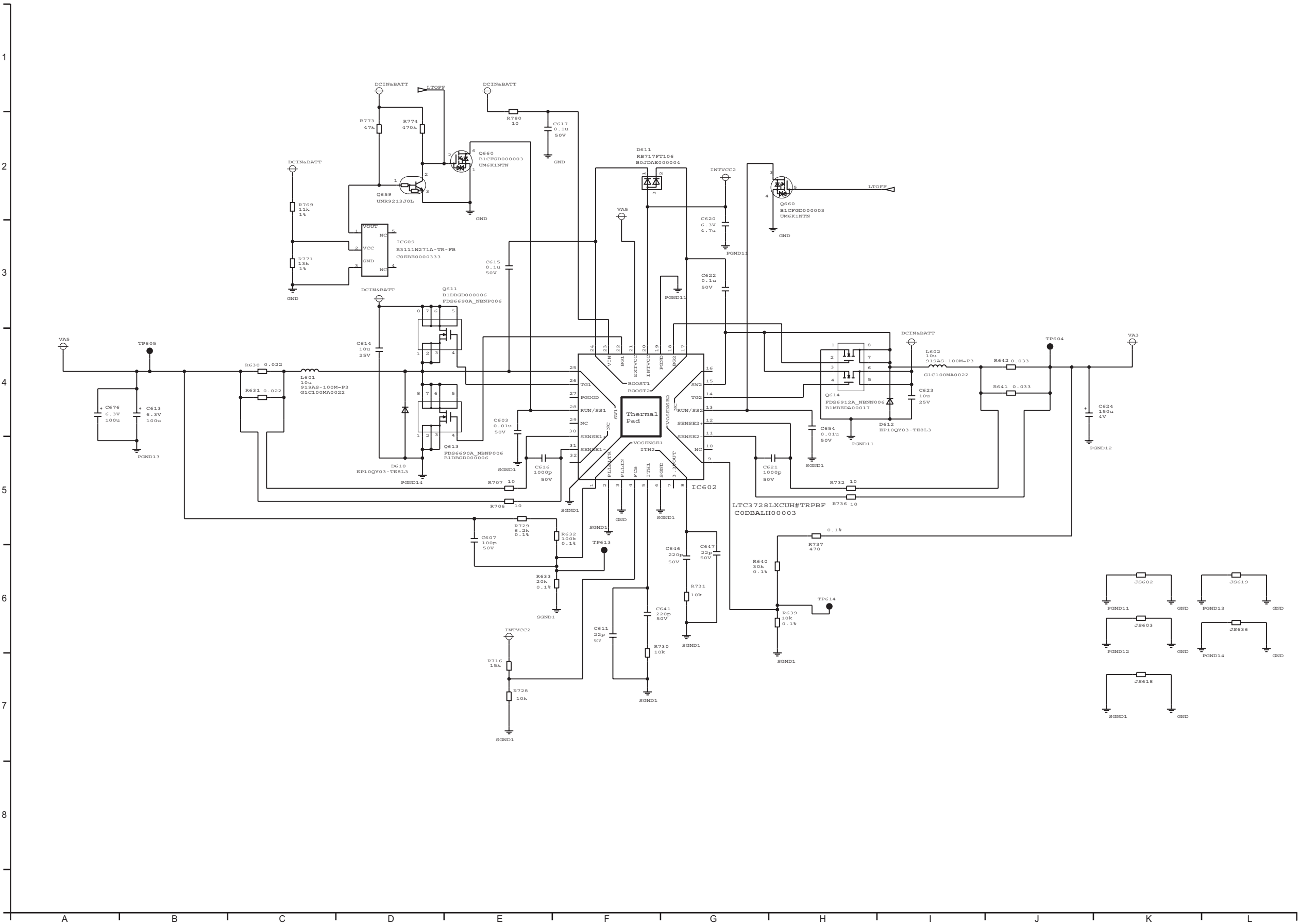

Main 29 VB3, VC3, VB5, VC5, VC15, OFF

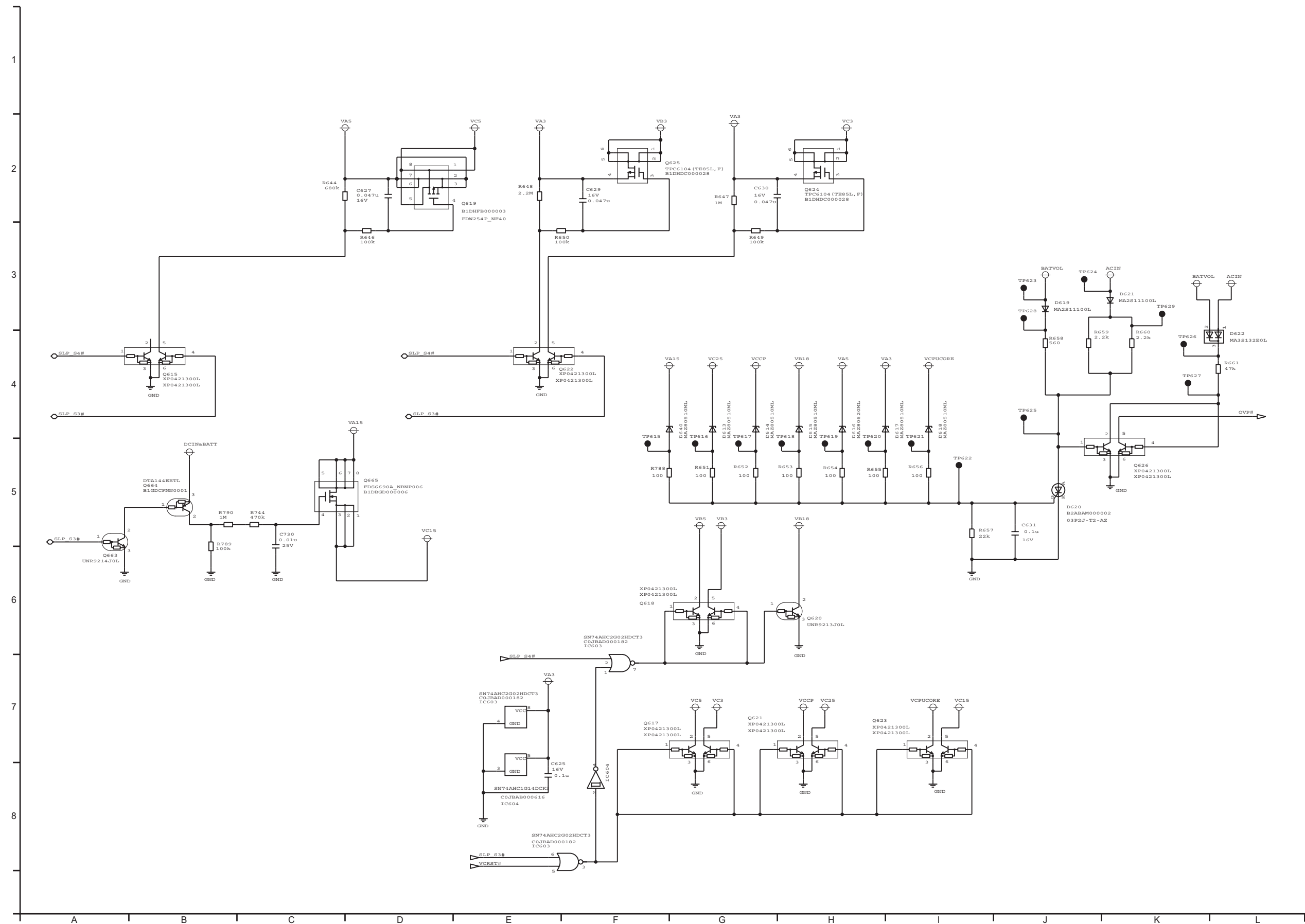

Main 30 VCPU CORE

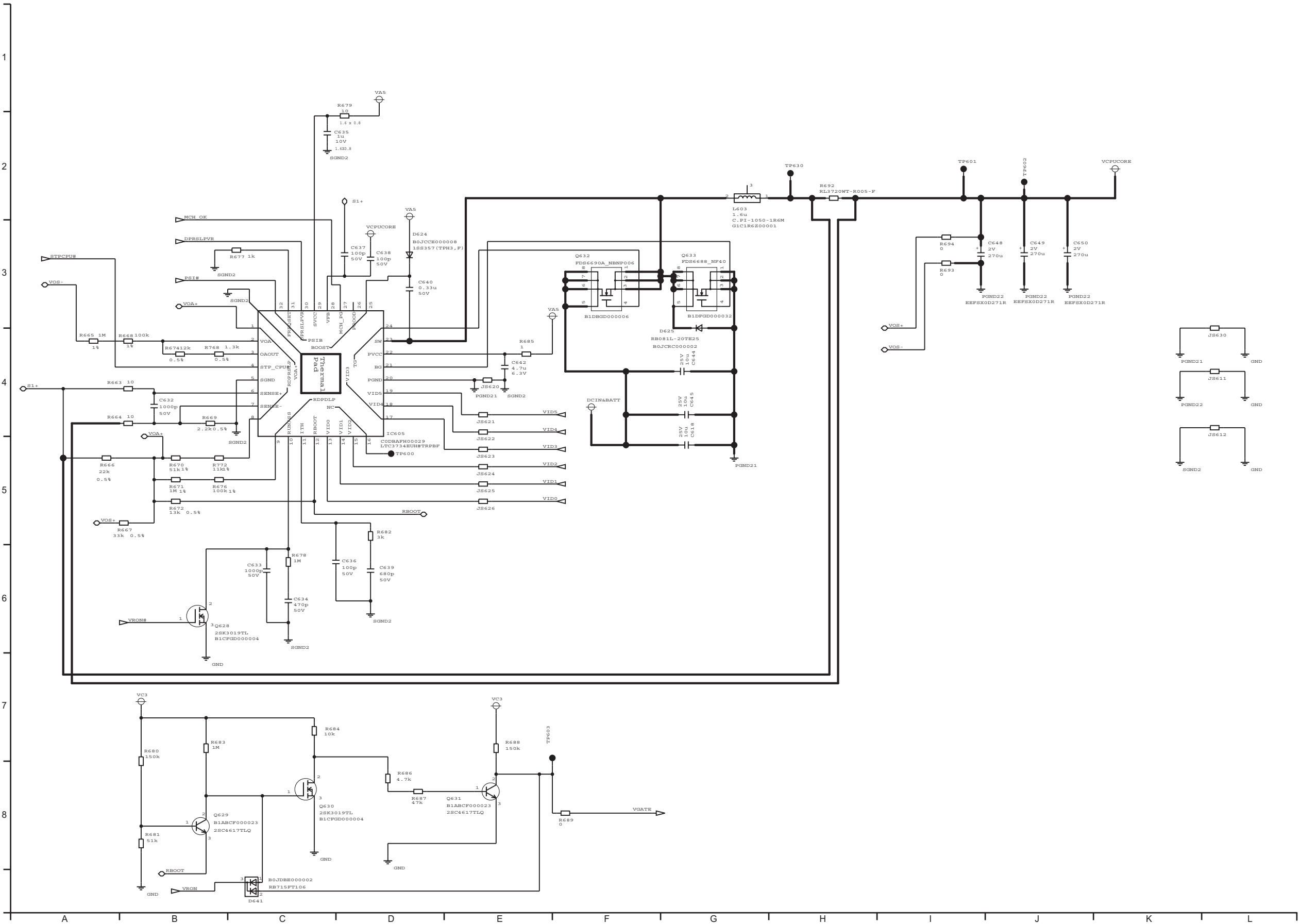

Main 31 VCCP (1.05V) , VC25

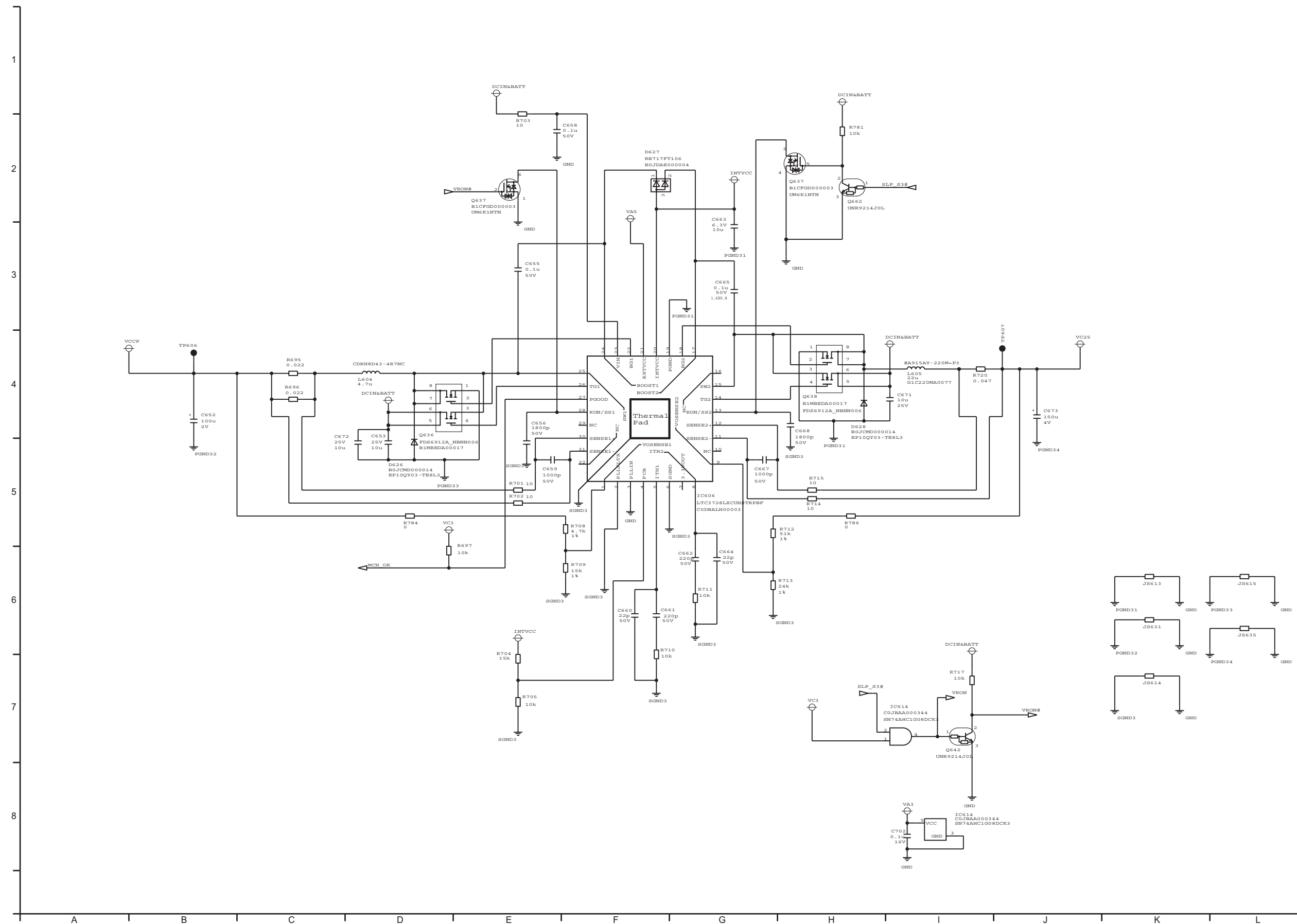

Main 32 VA15

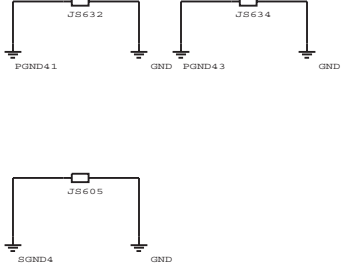
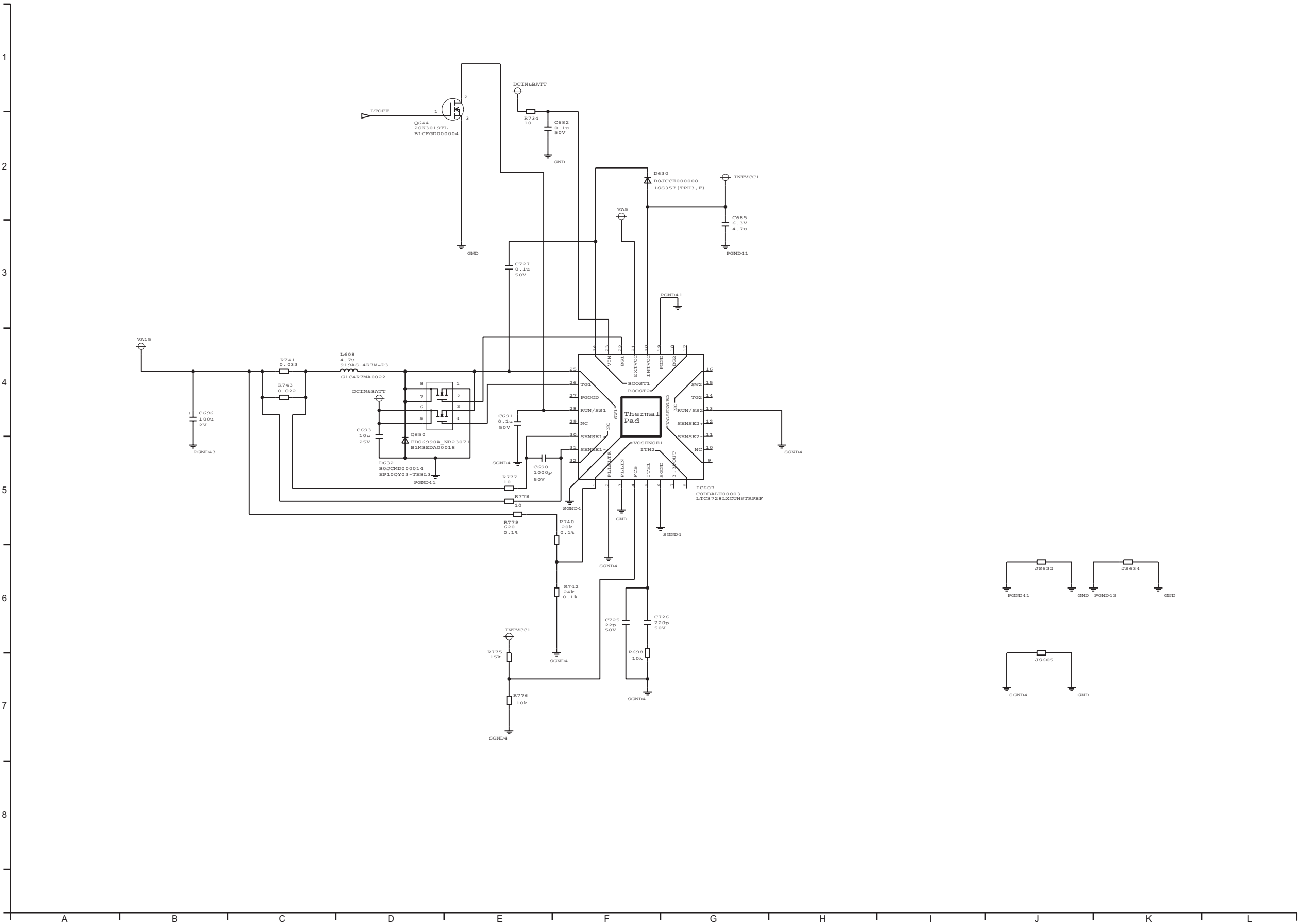

Main 33 VC09

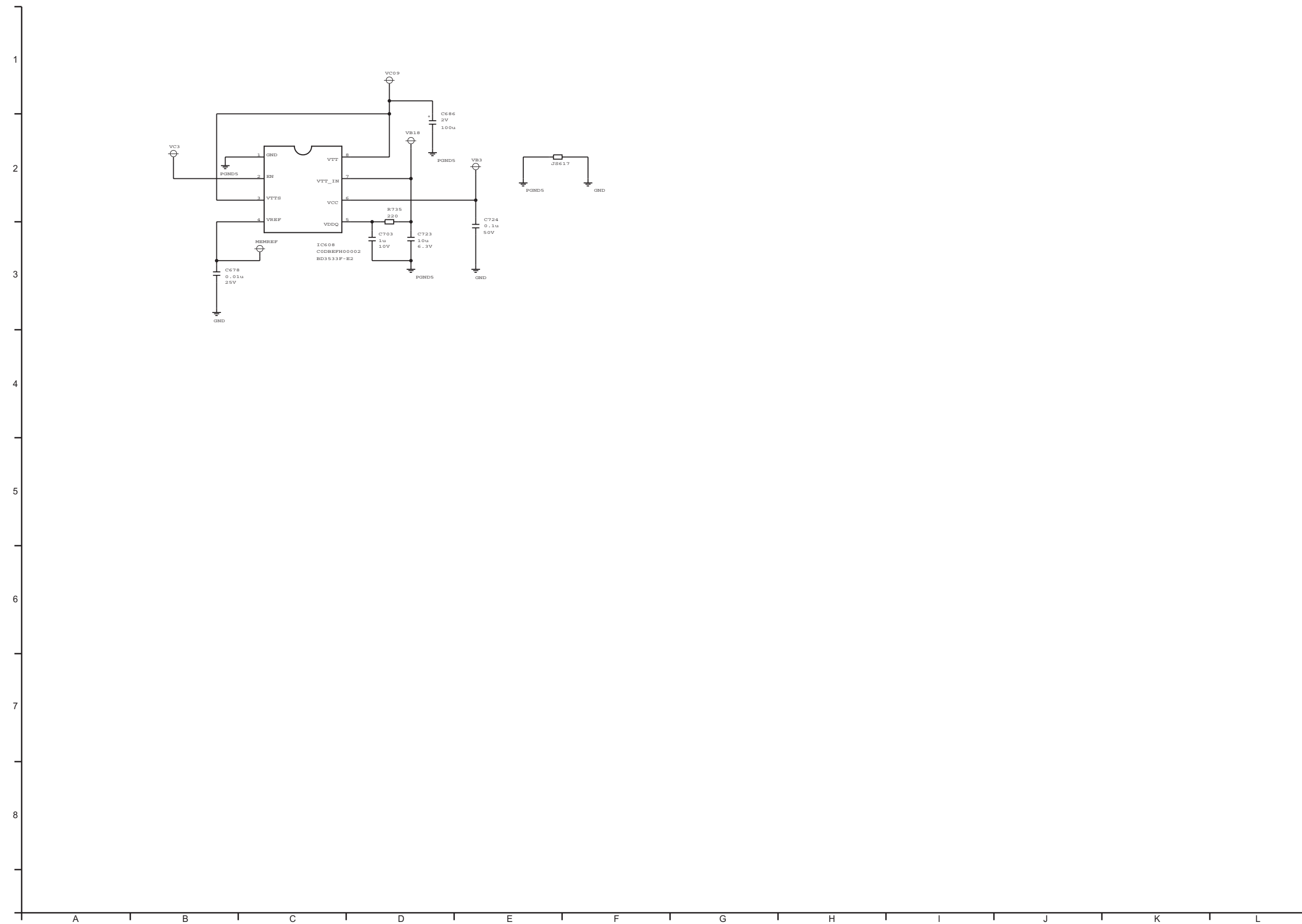

Main 34 BLANK

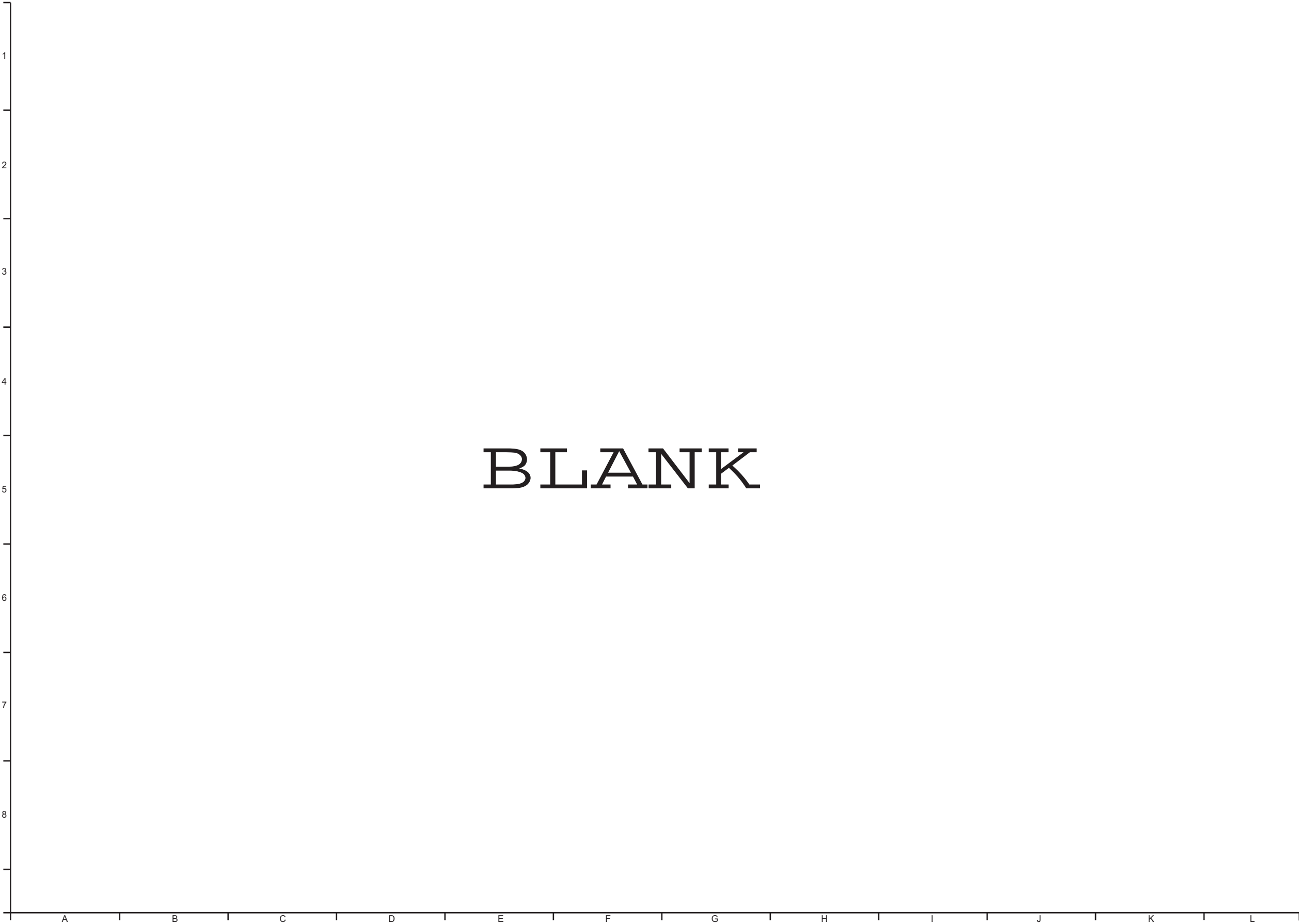

Main 35 CHARGER

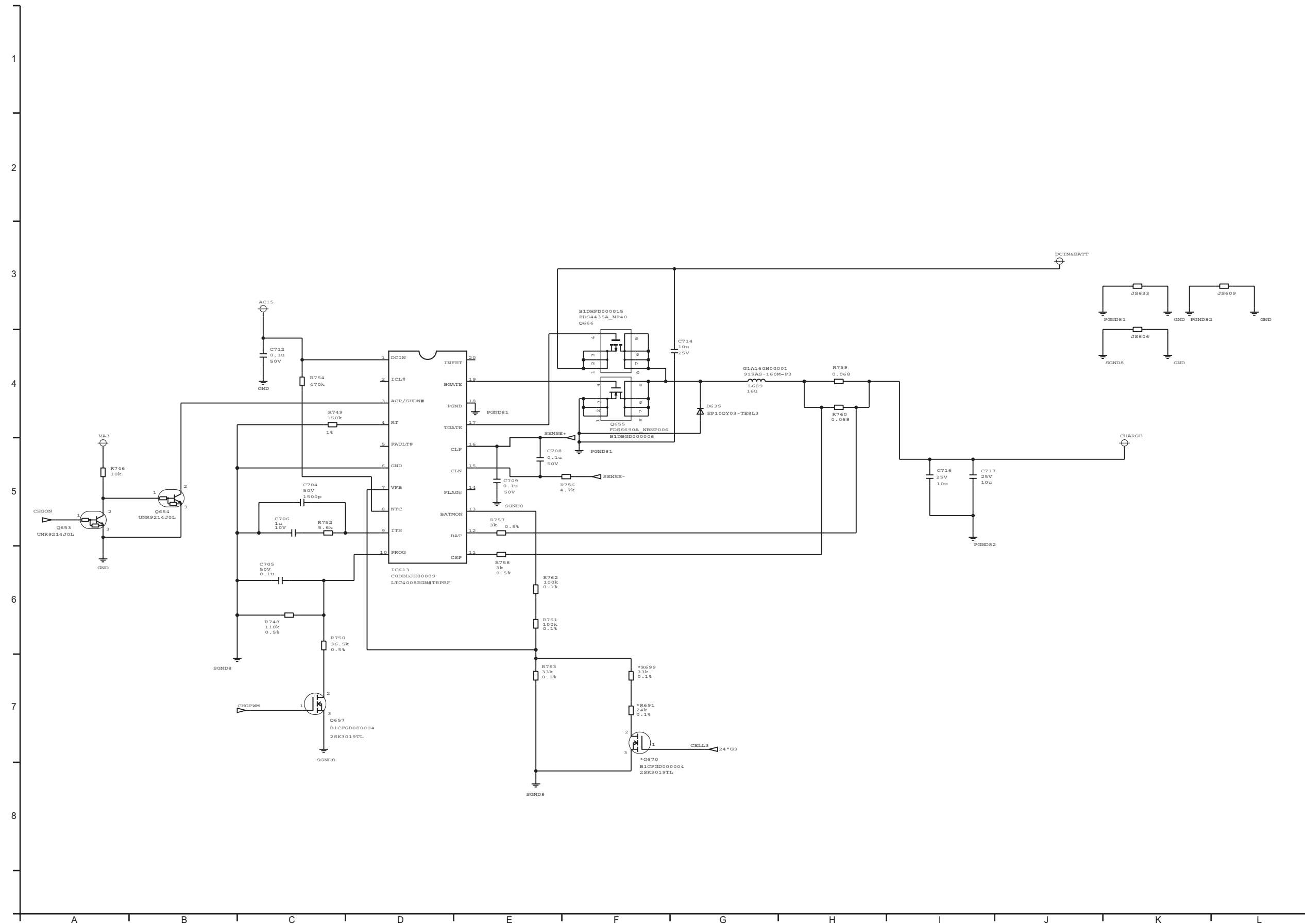

Main 37 VB18

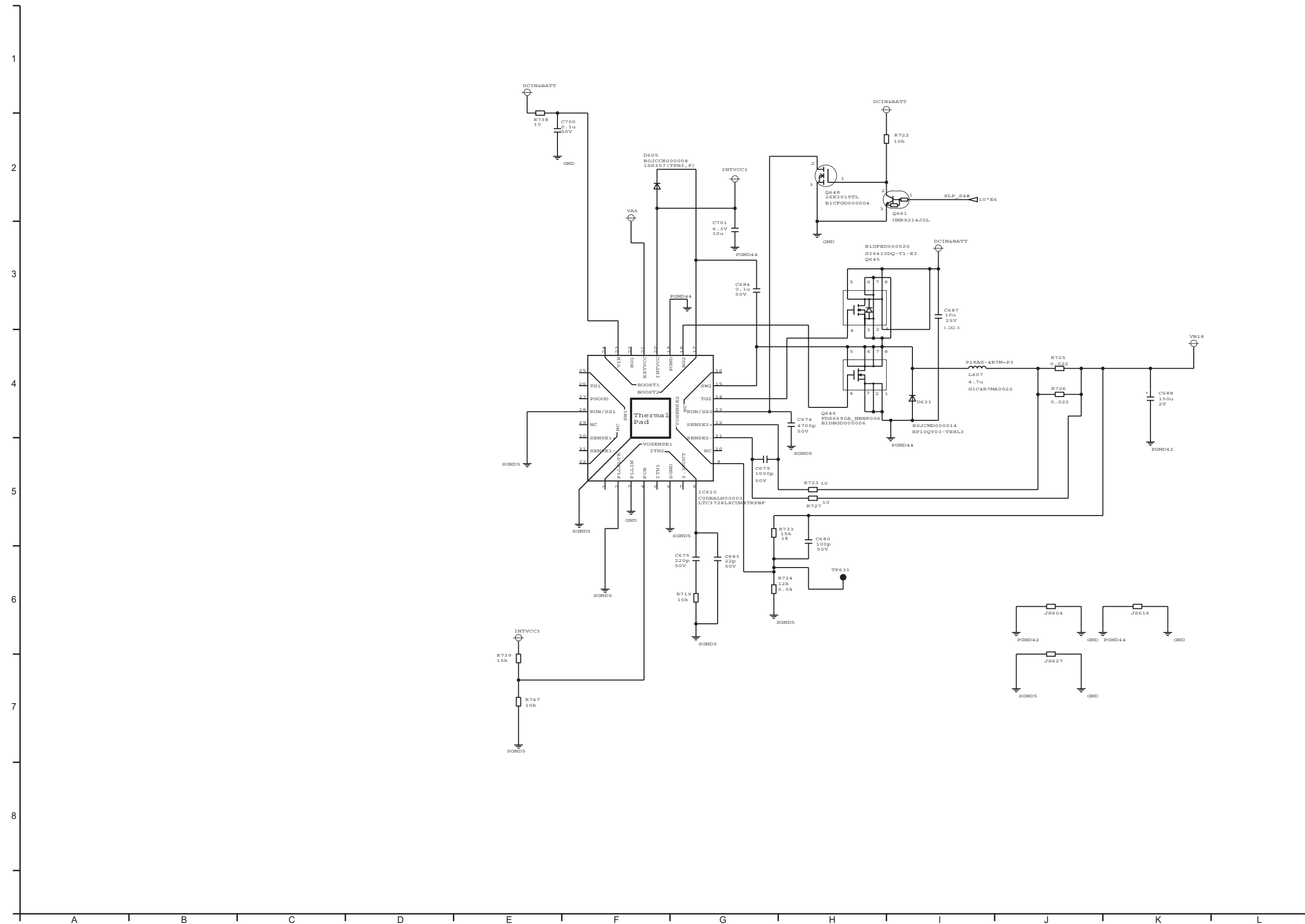

2PORT USB CN

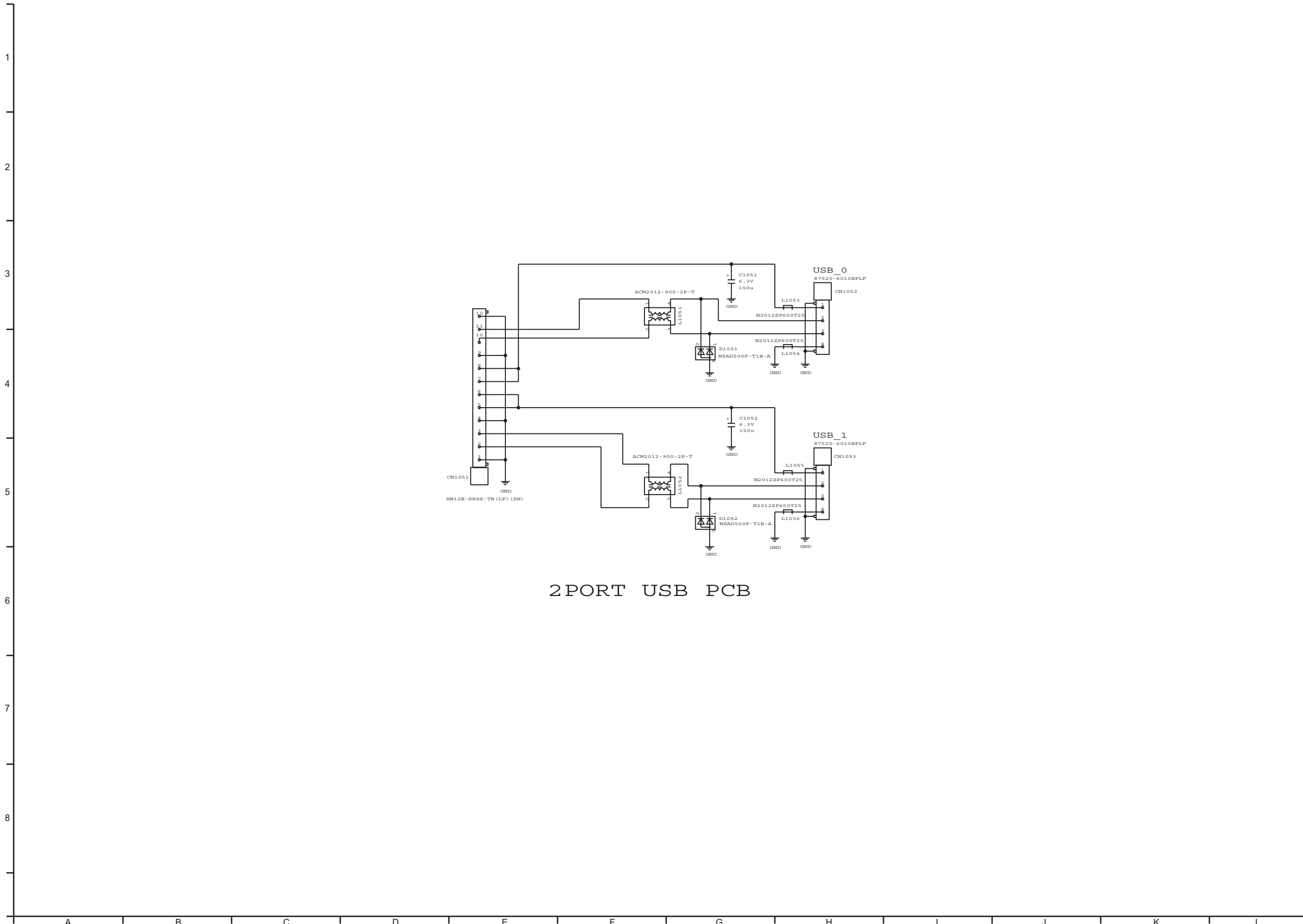

TS

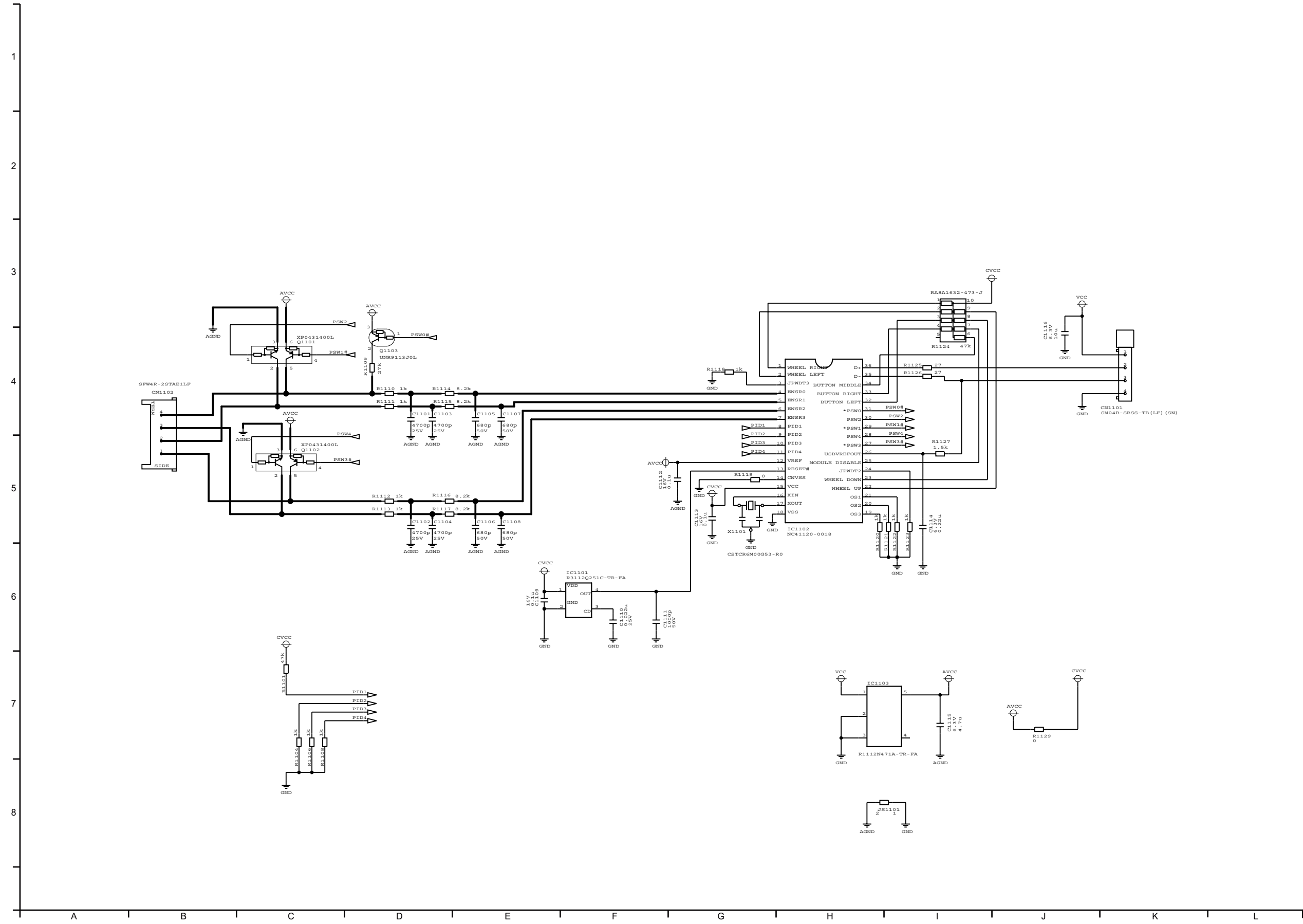

CF-T4 Printed Circuit Board

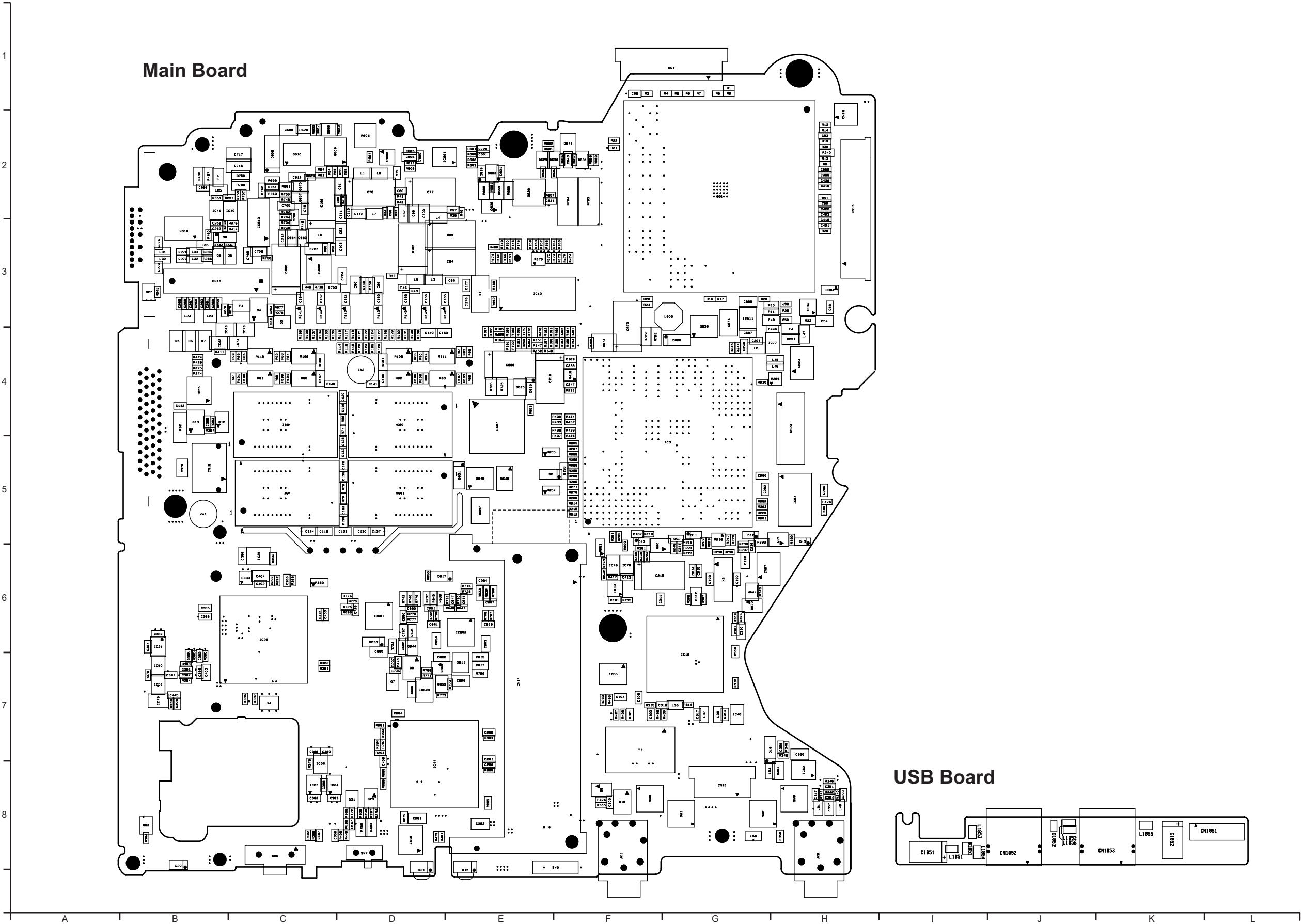

USB Board

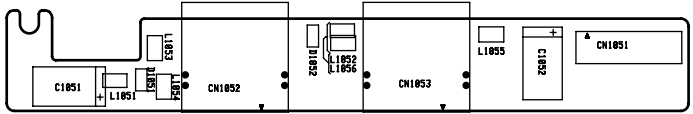

Main Board

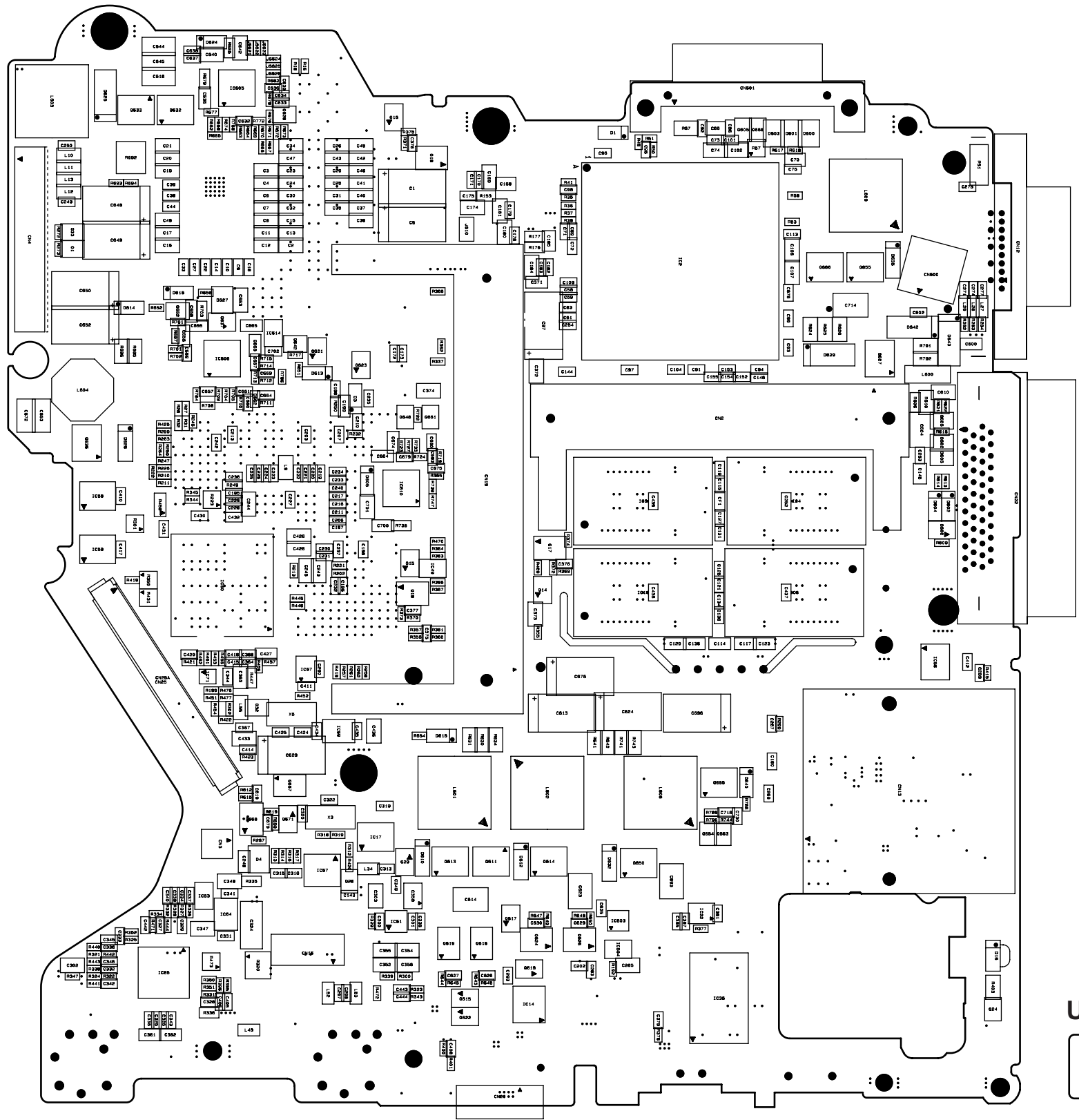

USB Board

