

Silicon Controlled Rectifier

DSCC Series 99003

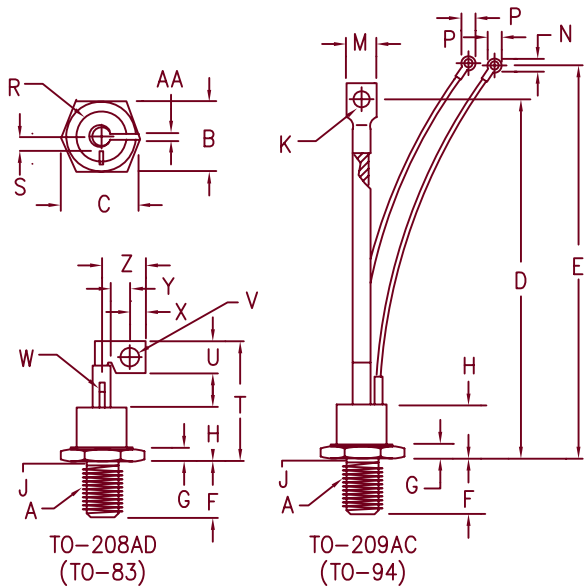

Note 1: 1/2-20 UNF-3A
 Note 2: Full thread within 2 1/2 threads

Dim.	Inches		Millimeter		Notes
	Minimum	Maximum	Minimum	Maximum	
A	---	---	---	---	1
B	1.050	1.060	26.67	26.92	
C	---	1.161	---	29.49	
D	5.850	6.144	149.10	156.06	
E	6.850	7.375	173.99	187.33	
F	.797	.827	20.24	21.01	
G	.276	.286	.701	7.26	
H	---	.948	---	24.08	
J	.425	.499	10.80	12.67	2
K	.260	.280	6.60	7.11	Dia.
M	.500	.600	12.70	15.24	
N	.140	.150	3.56	3.81	
P	---	.295	---	7.49	
R	---	.900	---	22.86	Dia.
S	.225	.275	6.48	6.99	
T	---	1.750	---	44.45	
U	.370	.380	9.40	9.65	
V	.213	.223	5.41	5.66	Dia.
W	.065	.075	1.65	1.91	Dia.
X	.215	.225	5.46	5.72	
Y	.290	.315	7.37	8.00	
Z	.514	.530	13.06	13.46	
AA	.089	.099	2.26	2.51	

Catalog Number

TO-83

TO-94

Forward & Reverse Repetitive Blocking

99003-2N1792	2	99003-2N1910	1	50V
99003-2N1793	2	99003-2N1911	1	100V
99003-2N1795	2	99003-2N1913	1	200V
99003-2N1797	2	99003-2N1915	1	300V
99003-2N1798	2	99003-2N1916	1	400V
99003-2N1799	2	99003-2N1805	1	500V
99003-2N1800	2	99003-2N1806	1	600V

- Replacement for MIL-PFR-19500/204
- Available as JAN, JANTX, JANTXV equivalent
- 1000 Amperes surge current
- 200V/us dv/dt
- 40 us turn-off time

Electrical Characteristics

Max. RMS on-state current	$I_T(\text{RMS})$ 79 Amps	$T_C = 83^\circ\text{C}$
Max. average on-state cur.	$I_T(\text{AV})$ 50 Amps	$T_C = 83^\circ\text{C}$
Max. peak on-state voltage	V_{TM} 2.1 Volts	$I_{TM} = 220 \text{ A(peak)}$
Max. holding current	I_H 75 mA	
Max. peak one cycle surge current	I_{TSM} 1000 A	$T_C = 83^\circ\text{C}, 60 \text{ Hz}$
Max. I^2t capability for fusing	I^2t 4,150A ² S	$t = 8.3 \text{ ms}$

Thermal and Mechanical Characteristics

Operating junction temp range	T_J	-40°C to 125°C
Storage temperature range	T_{STG}	-40°C to 150°C
Maximum thermal resistance	$R_{\theta JC}$	0.40°C/W Junction to case
Typical thermal resistance (greased)	$R_{\theta CS}$	0.20°C/W Case to sink
Max mounting torque		150 inch pounds
Weight		TO-94 Approx. 3.6 ounces (102.0 grams) typical TO-83 Approx. 3.24 ounces (91.8 grams) typical

DSCC Series 99003

Switching

Critical rate of rise of on-state current (note 1)	di/dt	100A/usec.	$T_J = 125^\circ\text{C}$
Typical delay time (note 1)	t_d	3.0 usec.	
Typical circuit commuted turn-off time (note 2)	t_q	40 usec.	$T_J = 100^\circ\text{C}$

Note 1: $I_{TM} = 50\text{A}$, $V_D = V_{DRM}$, $V_{GT} = 12\text{V}$ open circuit, 20 ohm-0.1 usec. rise time
 Note 2: $I_{TM} = 50\text{A}$, $di/dt = 50\text{A (pk)}$, $t_{on} = 100 + 50\text{usec}$, $-di/dt = 25\text{A/usec}$, $V_R = 50\text{V}$
 $dv/dt = 20\text{V/usec}$, $V_{DRM} = \text{rated}$

Triggering

Max. gate voltage to trigger	V_{GT}	3.0V	$T_J = 25^\circ\text{C}$
Max. nontriggering gate voltage	V_{GD}	0.25V	$T_J = 125^\circ\text{C}$
Max. gate current to trigger	I_{GT}	70mA	$T_J = 25^\circ\text{C}$
Max. peak gate power	P_{GM}	5W	
Average gate power	$P_{G(AV)}$	0.5W	$t_p = 10 \text{ usec.}$
Max. peak gate current	I_{GM}	2.0A	
Max. peak gate voltage (forward)	V_{GM}	10V	
Max. peak gate voltage (reverse)	V_{GM}	-5.0V	

Blocking

Max. leakage current	I_{DRM}	5mA	$T_J = 125^\circ\text{C} \ \& \ V_{DRM}$
Max. reverse leakage	I_{RRM}	5mA	$T_J = 125^\circ\text{C} \ \& \ V_{RRM}$
Critical rate of rise of off-state voltage	dv/dt	200V/usec.	$T_J = 125^\circ\text{C}$

DSCC Series 99003

Figure 1
Typical Forward On-State Characteristics

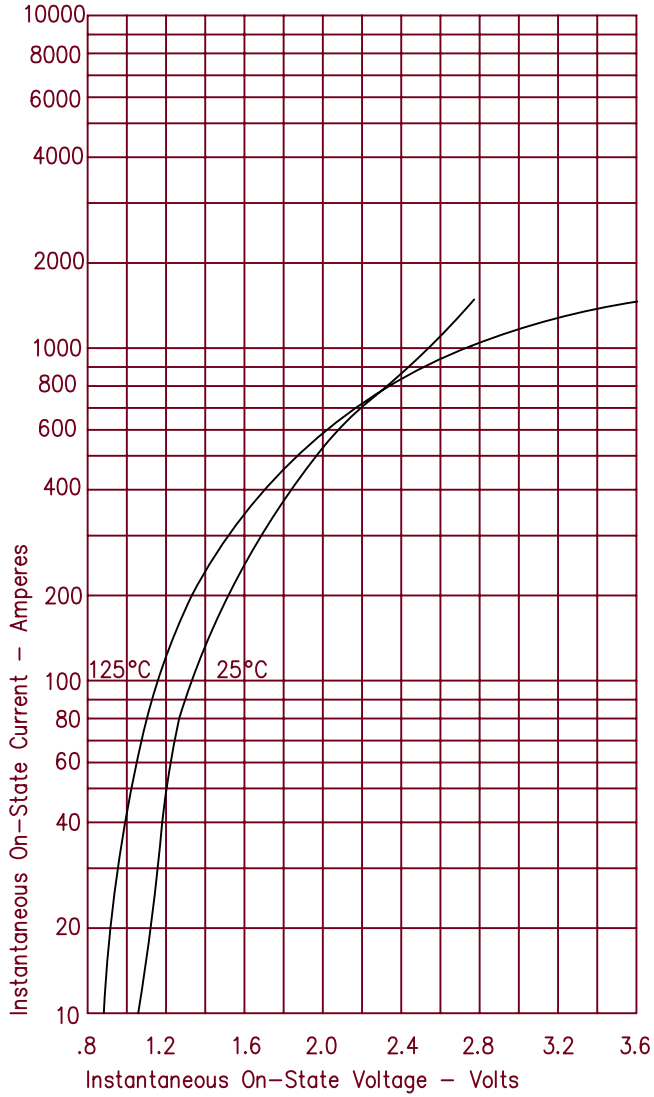

Figure 3
Transient Thermal Impedance

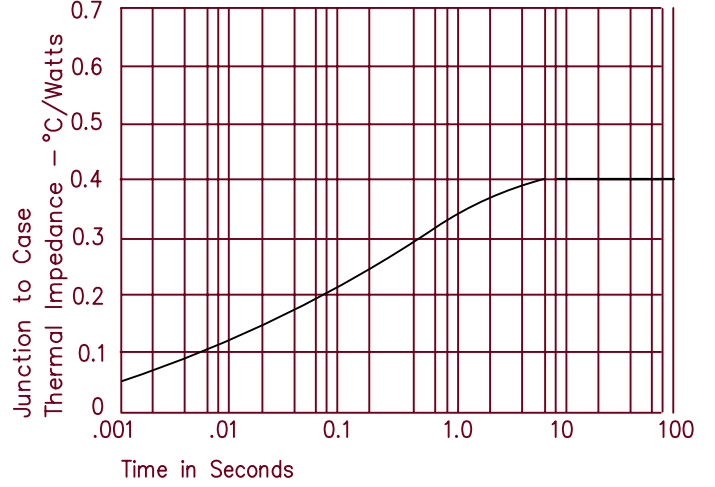

Figure 2
Forward Current Derating

