

Sensors

Quarter 3, 2009
SG1010Q32009 Rev 0

Datasheet.Live



ACCELERATION SENSORS

Low g Digital Output Consumer Acceleration Sensors

Product	Sensing Range (±g)	Sensing Axis	High Sensitivity (LSB/g)	I _{DD} (µA)	Sleep Mode Response Time (Typ) (ms)	Start Up Response Time (Typ) (ms)	I _{DD} for Modes Off/Power Down/Standby (µA)	V _{DD} Supply Voltage (Typ) (V) V _{DD} /V _{DD}	Digital I/O Pins V _{DD} Supply Voltage (Typ) (V)	Communication	Packaging
MMA7660FC	1.5	XYZ	21	47 at 1 sample/second	0.5	1/ODR (s)	0.4/2/2	2.8/1.8	1.8	I ² C	3 x 5 x 0.9mm DFN
MMA7456L	2/4/8	XYZ	64	400	0.5	1.0	—/—/2.5	2.8/1.8	1.8	I ² C/SPI	3 x 5 x 1.0 mm LGA
MMA7455L	2/4/8	XYZ	64	400	0.5	1.0	—/—/2.5	2.8/1.8	1.8	I ² C/SPI	3 x 5 x 1.0 mm LGA

Low g Analog Output Consumer Acceleration Sensors

Product	Sensing Range (±g)	Sensing Axis	Sensitivity (mV/V/g)	I _{DD} (Typ) (mA)	Sleep Mode (Typ) I _{DD} (µA)	Sleep Mode Response Time (Typ) (ms)	Start Up Response Time (Typ) (ms)	Rolloff Frequency (Hz)	V _{DD} Supply Voltage (V)	Zero g Output (Typ) (V)	Packaging
MMA7361L	1.5/6	XYZ	800/200	0.4	3.0	0.5	1.0	400 (XY)/300 (Z)	2.2 – 3.6	1.65	3 x 5 x 1.0 mm LGA
MMA7368L	1.5	XYZ	800	0.4	3.0	0.5	1.0	400 (XY)/300 (Z)	2.2 – 3.6	1.65	3 x 5 x 1.0 mm LGA
MMA7341L	3/11	XYZ	440/118	0.4	3.0	0.5	1.0	400 (XY)/300 (Z)	2.2 – 3.6	1.65	3 x 5 x 1.0 mm LGA
MMA7331L	4/12	XYZ	308/84	0.4	3.0	0.5	1.0	400 (XY)/300 (Z)	2.2 – 3.6	1.4	3 x 5 x 1.0 mm LGA
MMA7260Q	1.5/2/4/6	XYZ	800/600/300/200	0.5	3.0	0.5	1.0	350 (XY)/150 (Z)	2.2 – 3.6	1.65	6 x 6 x 1.45 mm QFN

Low g Automotive and Industrial Acceleration Sensors

Product	Sensing Range (±g)	Sensing Axis	Sensitivity (mV/V/g)	Rolloff Frequency (Hz)	V _{DD} Supply Voltage (Typ) (V)	Zero g Output (Typ) (V)	Output	Packaging
MMA2260EG	1.5	X	240	50	5.0	2.5	Analog	16-pin SOIC
MMA2240EG	7.0	X	60	400	5.0	2.5	Analog	16-pin SOIC
MMA1260EG	1.5	Z	240	50	5.0	2.5	Analog	16-pin SOIC
MMA1270EG	2.5	Z	150	50	5.0	2.5	Analog	16-pin SOIC
MMA1250EG	5.0	Z	80	50	5.0	2.5	Analog	16-pin SOIC
MMA1220EG	8.0	Z	50	250	5.0	2.5	Analog	16-pin SOIC

Medium g Automotive and Industrial Acceleration Sensors

Product	Sensing Range (±g)	Sensing Axis	Sensitivity (mV/V/g)	Rolloff Frequency (Hz)	V _{DD} Supply Voltage (Typ) (V)	Zero g Output (Typ) (V)	Output	Communication	Packaging
MMA6222EG	20/20	XY	24 counts/g	400	5.0	2.5	Digital	SPI	20-pin SOIC
MMA6222AEG	20/20	XY	23.4/23.4	400	5.0	2.5	Analog	—	20-pin SOIC
MMA3201EG	40	XY	10	400	5.0	2.5	Analog	—	20-pin SOIC
MMA2201EG	40	X	10	400	5.0	2.5	Analog	—	16-pin SOIC
MMA6255EG	50/50	XY	9.76 counts/g	400	5.0	2.5	Digital	SPI	20-pin SOIC
MMA6255AEG	50/50	XY	9.37/9.37	400	5.0	2.5	Analog	—	20-pin SOIC
MMA2202EG	50	X	8	400	5.0	2.5	Analog	—	16-pin SOIC
MMA3204EG	100/30	XY	4/13	400	5.0	2.5	Analog	—	20-pin SOIC
MMA3202EG	100/50	XY	4/8	400	5.0	2.5	Analog	—	20-pin SOIC
MMA621010EG	100/100	XY	4.88 counts/g	400	5.0	2.5	Digital	SPI	20-pin SOIC
MMA621010AEG	100/100	XY	4.68/4.68	400	5.0	2.5	Analog	—	20-pin SOIC
MMA2204EG	100	X	4	400	5.0	2.5	Analog	—	16-pin SOIC
MMA1213EG	50	Z	40	400	5.0	2.5	Analog	—	16-pin SOIC
MMA1210EG	100	Z	20	400	5.0	2.5	Analog	—	16-pin SOIC

A change bar appears in the left margin to mark the location of new or revised information.

ACCELERATION SENSORS (continued)

High g Automotive and Industrial Acceleration Sensors

Product	Sensing Range ($\pm g$)	Sensing Axis	Sensitivity (mV/V/g)	Rolloff Frequency (Hz)	V _{DD} Supply Voltage (Typ) (V)	Zero g Output (Typ) (V)	Output	Packaging
MMA1211EG	150	Z	13	400	5.0	2.5	Analog	16-pin SOIC
MMA2301EG	200	X	10	400	5.0	2.5	Analog	16-pin SOIC
MMA1212EG	200	Z	10	400	5.0	2.5	Analog	16-pin SOIC
MMA2300EG	250	X	8.0	400	5.0	2.5	Analog	16-pin SOIC
MMA1200EG	250	Z	8.0	400	5.0	2.5	Analog	16-pin SOIC

PRESSURE SENSORS

Digital Pressure Sensors

Product Family ¹	Operating Supply Voltage (V)	Supply Current (μA)	Pressure Range (kPa)	Accuracy (kPa)	Compensated Temperature Range	Digital Interface	Package	Pressure Type ²			
								A	D	G	V
MPL115A1	2.4 - 5.5	10	50 - 115	± 1	-20°C - 85°C	SPI	8-pin LGA	•			
MPL115A2	2.4 - 5.5	10	50 - 115	± 1	-20°C - 85°C	I ² C	8-pin LGA	•			

Integrated Pressure Sensors

Product Family ¹	Pressure Rating Maximum (PSI)	Pressure Rating Maximum (kPa)	Pressure Rating Maximum (in H ₂ O)	Pressure Rating Maximum (cm H ₂ O)	Pressure Rating Maximum (mm Hg)	Full Scale Span (Typ) (Vdc)	Sensitivity (mV/kPa)	Accuracy 0°C to 85°C (% of VFSS)	Pressure Type ²			
									A	D	G	V
MPX4080	11.6	80	321	815	600	4.3	54	± 3.0		•		
MPX4100	15.2	105	422	1070	788	4.6	54	± 1.8	•			
MPX4101	14.8	102	410	1040	765	4.7	54	± 1.72	•			
MPXH6101	14.8	102	410	1040	765	4.7	54	± 1.73	•			
MPX4105	15.2	105	422	1070	788	4.6	51	± 1.8	•			
MPX4115	16.7	115	462	1174	863	4.6	46	± 1.5	•			
	16.7	115	462	1174	863	4.4	38	± 1.5				•
MPX6115	16.7	115	462	1174	863	4.5	46	± 1.5	•			
MPX4200	29	200	803	2040	1500	4.6	26	± 1.5	•			
MPX4250	36	250	1000	2550	1880	4.7	20	± 1.5	•			
	36	250	1000	2550	1880	4.7	19	± 1.4		•	•	
MPXH6250	36	250	1000	2550	1880	4.7	20	± 1.5	•			
MPXV4006	0.87	6.0	24	61	45	4.6	766	± 5.0		•	•	
MPXV5004	0.57	4.0	16	40	29	3.0	1000	± 2.5		•	•	•
MPX5010	1.45	10	40	102	75	4.5	450	± 5.0		•	•	
MP3V5050	7.25	50	201	510	375	2.7	54	± 2.5		•	•	•
MPX5050	7.25	50	201	510	375	4.5	90	± 2.5		•	•	•
MPX5100	14.5	100	401	1020	750	4.5	45	± 2.5		•	•	
	16.7	115	462	1174	863	4.5	45	± 2.5	•		•	
MPX5500	72.5	500	2000	5100	3750	4.5	9.0	± 2.5		•		
MPX5700	102	700	2810	7140	5250	4.5	6.4	± 2.5	•	•	•	
MPX5999	150	1000	4150	10546	7757	4.5	4.5	± 2.5		•		
MPXH6300	44	304	1220	3100	2280	4.6	16.2	± 1.5	•			
MPXH6400	60	400	1600	4000	3000	4.6	12.1	± 1.5	•			
MPXV7002	± 0.3	± 2	± 8	± 20	± 15.2	4.0	1000	± 2.5		•		
MP3V7007	± 1.0	± 7	± 28	± 70	± 53	4.0	286	± 5.0		•	•	
MPXV7007	± 1.0	± 7	± 28	± 70	± 53	4.0	286	± 5.0		•	•	
MPXV7025	± 3.5	± 25	± 100	± 254	± 190	4.5	90	± 5.0		•	•	

A change bar appears in the left margin to mark the location of new or revised information.

PRESSURE SENSORS (continued)

Compensated Pressure Sensors

Product Family ¹	Pressure Rating Maximum (PSI)	Pressure Rating Maximum (kPa)	Pressure Rating Maximum (in H ₂ O)	Pressure Rating Maximum (cm H ₂ O)	Pressure Rating Maximum (mm Hg)	Offset (mV)	Full Scale Span (Typ) (mV)	Sensitivity (mV/kPa)	Linearity Minimum (% of VFSS)	Linearity Maximum (% of VFSS)	Pressure Type ²			
											A	D	G	V
MPX2010	1.45	10	40	102	75	±1.0	25	2.5	-1.0	1.0		•	•	
MPX2053	7.0	50	201	510	375	±1.0	40	0.8	-0.6	0.4		•	•	
MPX2102	14.5	100	400	1020	750	±2.0	40	0.4	-1.0	1.0	•	•	•	•
	14.5	100	400	1020	750	±1.0	40	0.4	-0.6	0.4				
MPX2202	29	200	800	2040	1500	±2.0	40	0.2	-1.0	1.0	•	•	•	
	29	200	800	2040	1500	±1.0	40	0.2	-0.6	0.4				
MPX2050	7.0	50	201	510	375	±1.0	40	0.8	-0.25	0.25		•	•	
MPX2100	14.5	100	400	1020	750	±2.0	40	0.4	-1.0	1.0	•	•	•	•
	14.5	100	400	1020	750	±1.0	40	0.4	-0.25	0.25				
MPX2200	29	200	800	2040	1500	±1.0	40	0.2	-1.0	1.0	•	•	•	
	29	200	800	2040	1500	±1.0	40	0.2	-0.25	0.25				

Compensated Medical Grade Pressure Sensors

Product Family ¹	Pressure Rating Maximum (PSI)	Pressure Rating Maximum (kPa)	Pressure Rating Maximum (in H ₂ O)	Pressure Rating Maximum (cm H ₂ O)	Pressure Rating Maximum (mm Hg)	Supply Voltage (Typ) (Vdc)	Offset Maximum (mV)	Sensitivity (mV/kPa)	Linearity Minimum (% of VFSS)	Linearity Maximum (% of VFSS)	Pressure Type ²			
											A	D	G	V
MPXC2011	1.45	10	40	102	75	3.0	1.0	2.5	-1.0	1.0			•	
MPX2300DT1	5.8	40	161	408	300	6.0	0.75	0.23	-1.5	1.5			•	

Uncompensated Pressure Sensors

Product Family	Pressure Rating Maximum (PSI)	Pressure Rating Maximum (kPa)	Pressure Rating Maximum (in H ₂ O)	Pressure Rating Maximum (cm H ₂ O)	Pressure Rating Maximum (mm Hg)	Offset (Typ) (mV)	Full Scale Span (Typ) (mV)	Sensitivity (mV/kPa)	Linearity Minimum (% of VFSS)	Linearity Maximum (% of VFSS)	Pressure Type ²			
											A	D	G	V
MPX10	1.45	10	40	102	75	20	35	3.5	-1.0	1.0		•	•	
MPX12	1.45	10	40	102	75	20	55	5.5	-0.5	5.0		•	•	
MPX53	7.0	50	200	510	375	20	60	1.2	-0.6	0.4		•	•	

¹ The primary core pressure sensor families are listed above. For orderable parts, please see page 10 or www.freescale.com/sensors

² A = Absolute, D = Differential, G = Gauge, V = Vacuum, • = Available

PROXIMITY SENSORS

Product	Main Attributes	Shield Driver	No. of Channels	5 V Reg. Current Limit (mA)	Operating Voltage (V)	Operating Temp Range (°C)	Communications	Packaging
MPR031	Controls two electrodes with $\overline{\text{IRQ}}$ and can have 3 electrodes without $\overline{\text{IRQ}}$, extremely small package	No	3	n/a	1.71 - 2.75	-40° - 85°	I ² C with $\overline{\text{IRQ}}$	µDFN
MPR032	Ability to be the second address on the I ² C bus, the MPR032 works in daisy chain with the MPR031 to reach up to 6 pads, extremely small package	No	3	n/a	1.71 - 2.75	-40° - 85°	I ² C with $\overline{\text{IRQ}}$	µDFN
MC33794EGR2	120 kHz generator, shield driver, 9 electrodes + 2 VREF outputs, 5 V regulator, RF/environmental noise resistant	Yes	9	75	9 - 18 (12 nominal)	-40° - 85°	ISO-9141	54-pin SOICW
MC33941EGR2	Sensitivity scaling with output frequency variation, shield driver, 7 electrodes, 5 V regulator, RF/environmental noise resistant, End of Life	Yes	7	75	9 - 18 (12 nominal)	-40° - 110°	n/a	24-pin SOICW

REMOTE PRESSURE MONITORING SYSTEM (RPMS)

Product	Flash	RAM	RF Transmitter Frequency	Protocols Supported	Clock Type	Timer	Pressure Range	Pressure Sensor Accuracy	Package	Temperature Range	System Accelerometer
MPXY8300A	16 KB	512 B	315/434MHz	ASK and FSK Modulation	OSC	2-CH, 16-bit PWM	100 - 800 kPa	±10 kPa	SOIC-20 WB	-40 to 125°C	Automotive Pressure Range (XZ-Axis)
MPXY8300B	16 KB	512 B	315/434MHz	ASK and FSK Modulation	OSC	2-CH, 16-bit PWM	100 - 800 kPa	±10 kPa	SOIC-20 WB	-40 to 125°C	Automotive Pressure Range (Z-Axis)
MPXY8300C	16 KB	512 B	315/434MHz	ASK and FSK Modulation	OSC	2-CH, 16-bit PWM	100 - 800 kPa	±10 kPa	SOIC-20 WB	-40 to 125°C	—
MPXY8310A	16 KB	512 B	315/434MHz	ASK and FSK Modulation	OSC	2-CH, 16-bit PWM	100 - 450 kPa	±7 kPa	SOIC-20 WB	-40 to 125°C	Automotive Pressure Range (XZ-Axis)
MPXY8310B	16 KB	512 B	315/434MHz	ASK and FSK Modulation	OSC	2-CH, 16-bit PWM	100 - 450 kPa	±7 kPa	SOIC-20 WB	-40 to 125°C	Automotive Pressure Range (Z-Axis)
MPXY8310C	16 KB	512 B	315/434MHz	ASK and FSK Modulation	OSC	2-CH, 16-bit PWM	100 - 450 kPa	±7 kPa	SOIC-20 WB	-40 to 125°C	—
MPXY8320A	16 KB	512 B	315/434MHz	ASK and FSK Modulation	OSC	2-CH, 16-bit PWM	100 - 1500 kPa	±20 kPa	SOIC-20 WB	-40 to 125°C	Truck Tire Pressure Range (XZ-Axis)
MPXY8320B	16 KB	512 B	315/434MHz	ASK and FSK Modulation	OSC	2-CH, 16-bit PWM	100 - 1500 kPa	±20 kPa	SOIC-20 WB	-40 to 125°C	Truck Tire Pressure Range (Z-Axis)
MPXY8320C	16 KB	512 B	315/434MHz	ASK and FSK Modulation	OSC	2-CH, 16-bit PWM	100 - 1500 kPa	±20 kPa	SOIC-20 WB	-40 to 125°C	—

ZigBee® TECHNOLOGY PRODUCTS

The Freescale Semiconductor ZigBee Technology Products offer a comprehensive, scalable platform designed for a variety of monitoring, automation, and control applications in the home, commercial, industrial, and medical environments. The platform enables cost-effective, low-power applications ranging from simple point-to-point networks through fully compliant ZigBee mesh networks. Freescale is a complete one-stop-shop for wireless connectivity designs offering the MC1320x family of transceivers and the MC1321x family of System in a Package or SiP solutions (which contain both the MCU and transceiver in a single package). All solutions are supported by the easy to use BeeKit™ GUI-based software and the 1321x development hardware. The product offerings can be used to implement a variety of MAC options including the proprietary Simple MAC (SMAC), IEEE® 802.15.4 MAC, and the BeeStack™ fully compliant ZigBee stack. The Generation II MC1320x transceivers offer designers the alternative to select Freescale microcontrollers from the HCS08GB, HCS08GT, and HCS08QE series which connect to the transceivers through a 4-wire serial peripheral interface or SPI. Flexibility, easy to use products, software and hardware design tools, and the right performance at the right price provide embedded designers the optimized solution to meet their wireless personal area network (WPAN) application objectives.

MC1320x Transceivers

Product	Supply Voltage (V)	Supply Current @ 1% Duty Cycle (Typ) mA	Standby Current (Typ) µA	Frequency Band GHz	Sensitivity @ 1% PER (Typ) dBm	Serial Interface	Data Rate (Spec) kbps	Tx/RX Switch	Communication Protocol	Packaging
MC13201FC (18B)	2.0 to 3.4	30, TX 37, RX	500	2.4-2.5	-92	SPI	250	Yes	Simple MAC	1311 (32 QFN)
MC13202FC (18B)	2.0 to 3.4	30, TX 37, RX	500	2.4-2.5	-92	SPI	250	Yes	Simple MAC/IEEE®802.15.4 MAC/BeeStack™	1311 (32 QFN)

MC1321x System in a Package

The MC1321x System in a Package or SiP solutions include Freescale's 2.4 GHz RF transceiver and the HCS08 microcontroller in a single package, providing for a cost-effective solution that reduces system external component counts. Similar to the MC1320x family of transceivers, the MC1321x SiP family supports a variety of MAC options including the proprietary Simple MAC (SMAC), IEEE 802.15.4 MAC, and the BeeStack fully compliant ZigBee stack. The MC13211 is the ideal option for Simple MAC networks which require a smaller memory footprint, 16KB of MCU memory. The MC13212 best supports the Simple MAC and IEEE 802.15.4 MAC networks with its 32KB of MCU memory. The MC13213 supports the Simple MAC, IEEE 802.15.4 MAC and the BeeStack networks with its 60KB of MCU memory.

ZigBee-Compliant SiP Products

Product	CPU	Memory	Peripherals	Supply Voltage (V)	Supply Current @ 1% Duty Cycle, CPU @ 2MHz (Typ) mA	Standby Current (Typ) µA	Frequency Band (GHz)	Sensitivity @ 1% PER (Typ) dBm	Data Rate (Spec) kbps	Tx/RX Switch	Communication Protocol	Packaging
MC13211 (18m)	HCS08	16KB Flash 1KB RAM	I ² C, SCI (2), Timer/PWM(2), KBI, 8-CH 10-bit ADC, Up to 32 GPIO	2.0 to 3.4	31.1, TX 38.1, RX	0.675	2.4-2.5	-92	250	Yes	Simple MAC	1664 (71-LGA)
MC13212 (18m)	HCS08	32KB Flash 2KB RAM	I ² C, SCI (2), Timer/PWM(2), KBI, 8-CH 10-bit ADC, Up to 32 GPIO	2.0 to 3.4	31.1, TX 38.1, RX	0.675	2.4-2.5	-92	250	Yes	Simple MAC/IEEE®802.15.4 MAC	1664 (71-LGA)
MC13213 (18m)	HCS08	60KB Flash 4KB RAM	I ² C, SCI (2), Timer/PWM(2), KBI, 8-CH 10-bit ADC, Up to 32 GPIO	2.0 to 3.4	31.1, TX 38.1, RX	0.675	2.4-2.5	-92	250	Yes	Simple MAC/IEEE®802.15.4 MAC/BeeStack™	1664 (71-LGA)

SENSOR TOOLBOX



Plug-and-Play: Unified hardware, software and accessories for sensor applications

Freescale's Sensor Toolbox offers a customizable selection of sensor development tools, accessories and software from Freescale's portfolio of acceleration, pressure and proximity touch sensors. Sensors enrich designs with a broad range of capabilities in detecting real-world conditions, such as motion, touch or pressure.



LFSTUSB: Accelerometer USB Communication Interface Board

The LFSTUSB Accelerometer USB Communication Interface board is intended for use paired with the Accelerometer Development Board, purchased separately.

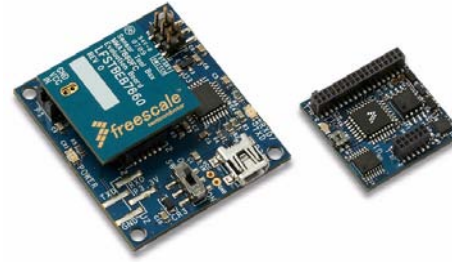

LFSTBEB7660: MMA7660FC Accelerometer Development Board

The LFSTBEB7660 MMA7660FC Accelerometer Development board is intended for use paired with an Accelerometer Interface Board, purchased separately.



KITPRESSURE1EVB: Pressure Sensor USB Communication Interface Board

The KITPRESSURE1EVB Pressure Sensor USB board is intended for use paired with the Accelerometer Development Board, purchased separately.



KITMPXV5004DPEVB: MPXV5004DP Pressure Sensor Development Board

The KITMPXV5004DPEVB MPXV5004DP Pressure Sensor Development board is intended for use paired with the Pressure Sensor Interface Board, purchased separately.



KITMPR03xEVM: MPR03x Proximity Touch Sensor Kit

The KITMPR03xEVM Proximity Sensor Kit has electrode boards that can be used with this interface board or interchangeable with other Sensor Toolbox touch sensor kits.

www.freescale.com/sensortoolbox

SENSOR DEVELOPMENT TOOLS



RD3172MMA7456L: Multiple Wireless Sensing Triple-Axis Reference Design (ZSTAR3)

The ZSTAR3, another successor to the popular STAR family accommodates multiple digital and analog accelerometer boards, connected through an RF ZigBee® 2.4 GHz communication to a single USB node connected to a PC.



RD3803MMA7660FC: XYZ-axis Digital Accelerometer Evaluation and Development Board

These evaluation boards can be used to demonstrate the multiple features of the MMA7660FC.

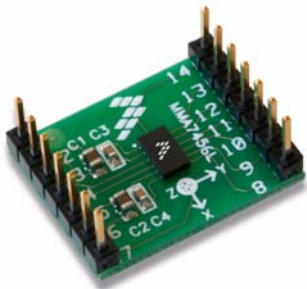

KIT3468MMA745XL: XYZ-axis Digital Accelerometer Evaluation Board

This evaluation board can be used to demonstrate key accelerometer features of the MMA7455L products.



KIT3376MMA73X1L: XYZ-axis Evaluation Boards

These evaluation boards can be used to demonstrate key accelerometer features of the MMA7361L, MMA7341L and MMA7331L products



KITMPL115A1SPI: MPL115A Digital Barometric Pressure Sensor Evaluation Board

This evaluation board demonstrates the SPI communication protocol.



KITMPL115A2I2C: MPL115A Digital Barometric Pressure Sensor Evaluation Board

This evaluation board demonstrates the I²C communication protocol.



DEMOMPR031:

Simplify touch sensing with this small stand alone demo board based on the MPR031 touch sensor.

PRODUCT NUMBERING SYSTEM FOR ACCELEROMETERS

AUTOMOTIVE DEVICES

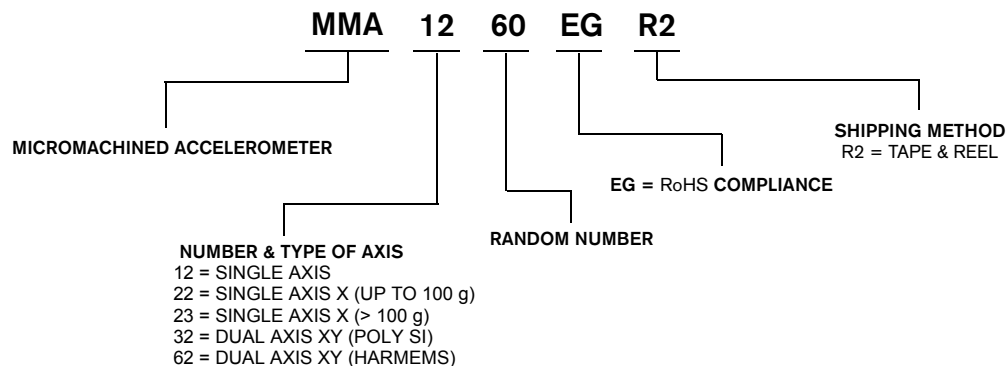

CONSUMER DEVICES

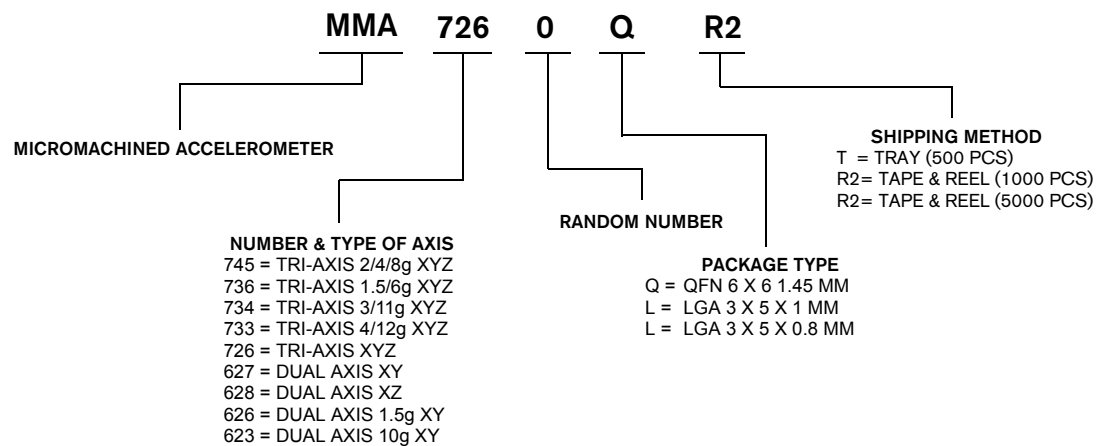

PRODUCT NUMBERING SYSTEM FOR PROXIMITY SENSORS

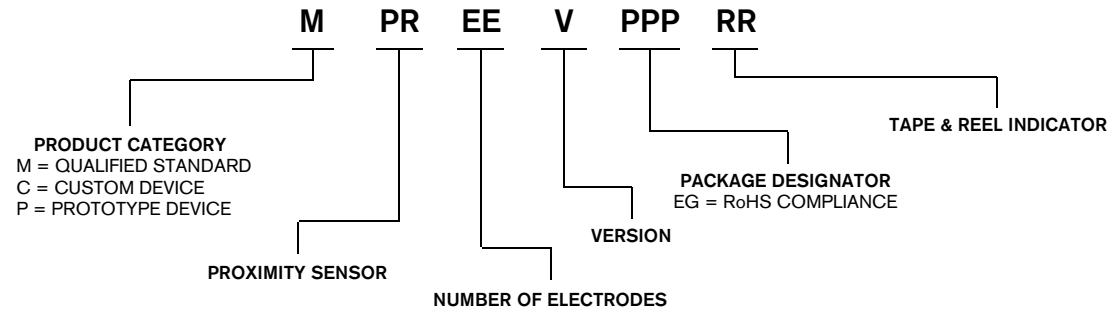

PRODUCT NUMBERING SYSTEM FOR PRESSURE SENSORS¹

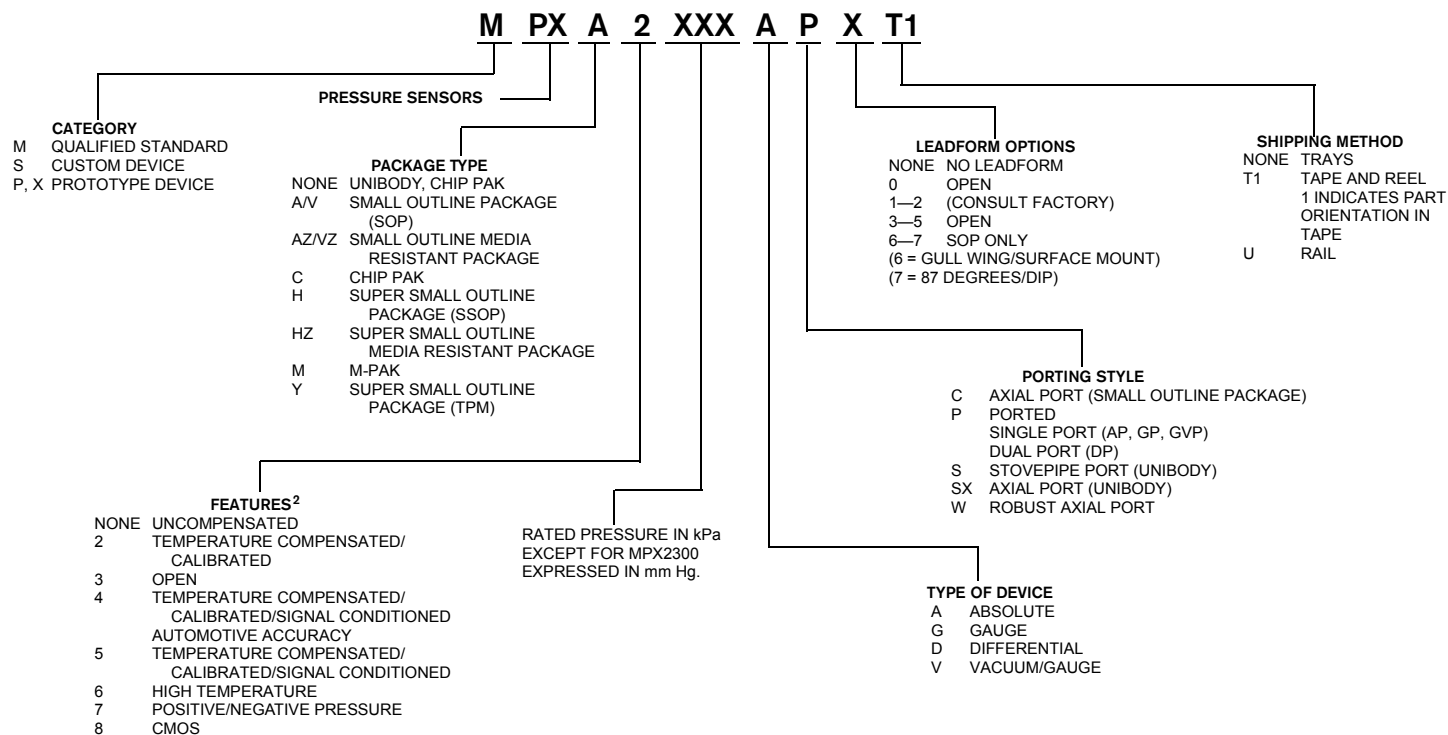

¹Actual product marking may be abbreviated due to space constraints but packaging label will reflect full part number.

²Only applies to qualified and prototype products. This does not apply to custom products.

Examples:

MPX10DP 10 kPa uncompensated, differential device in minibody package, ported, no leadform, shipped in trays.

MPXA4115A6T1 115 kPa automotive temperature compensated and calibrated device with signal conditioning, SOP surface mount with gull wing leadform, shipped in tape and reel.

PRESSURE SENSOR ORDERABLE PART NUMBERS

Digital Pressure

MPL115A1T1
MPL115A2T1

Integrated

MPXV7002DP
MPXV7002DPT1
MPXV7002GC6T1
MPXV7002GC6U
MPXV7002GP
MP3V5004DP
MP3V5004GC6T1
MP3V5004GC6U
MP3V5004GP
MP3V5004GVP
MPVZ5004G6T1
MPVZ5004G6U
MPVZ5004G7U
MPVZ5004GC6U
MPVZ5004GW6U
MPVZ5004GW7U
MPXV5004DP
MPXV5004GC6T1
MPXV5004GC6U
MPXV5004GC7U
MPXV5004GP
MPXV5004GPT1
MPXV5004GVP
MPVZ4006G6T1
MPVZ4006G6U
MPVZ4006G7U
MPVZ4006GW6U
MPVZ4006GW7U
MPXV4006DP
MPXV4006GC6T1
MPXV4006GC6U
MPXV4006GC7U
MPXV4006GP
MP3V7007DP
MP3V7007GC6T1
MP3V7007GC6U

MP3V7007GP
MPXV7007DP
MPXV7007DPT1
MPXV7007G6T1
MPXV7007G6U
MPXV7007GC6T1
MPXV7007GC6U
MPXV7007GP
MPXV7007GPT1
MPVZ5010G6T1
MPVZ5010G6U
MPVZ5010G7U
MPVZ5010GW6U
MPVZ5010GW7U
MPX5010DP
MPX5010GP
MPX5010GS
MPX5010GSX
MPXV5010DP
MPXV5010G6U
MPXV5010GC6T1
MPXV5010GC6U
MPXV5010GC7U
MPXV5010GP
MPVZ7025DP
MPVZ7025G6T1
MPVZ7025G6U
MPVZ7025GC6T1
MPVZ7025GC6U
MPVZ7025GP
MPXV7025DP
MPXV7025DPT1
MPXV7025GC6T1
MPXV7025GC6U
MPXV7025GP
MPXV7025GPT1
MPXV5040GC6U
MP3V5050DP
MP3V5050GC6T1
MP3V5050GC6U

MP3V5050GP
MP3V5050VC6T1
MP3V5050VC6U
MPVZ5050GW7U
MPX5050D
MPX5050DP
MPX5050GP
MPX5050GP1
MPXV5050DP
MPXV5050GC6T1
MPXV5050GC6U
MPXV5050GP
MPXV5050VC
MPXV5050VC6T1
MPX4080D
MPX4100A
MPX4100AP
MPX4100AP1
MPX4100AS
MPXA4100A6T1
MPXA4100A6U
MPXA4100AC6U
MPXAZ4100A6U
MPXAZ4100AC6U
MPX5100A
MPX5100AP
MPX5100D
MPX5100DP
MPX5100GP
MPXV5100DP
MPXV5100GC6U
MPXV5100GC7U
MPXV5100GP
MPXH6101A6T1
MPXH6101A6U
MPXH6101AC6T1
MPXH6101AC6U
MPX4115A
MPX4115AP
MPX4115AS

MPXA4115A6T1
MPXA4115A6U
MPXA4115AC6U
MPXA4115AP
MPXAZ4115A6T1
MPXAZ4115A6U
MPXAZ4115AC6U
MPXV4115V6T1
MPXV4115V6U
MPXV4115VC6U
MP3H6115A6T1
MP3H6115A6U
MP3H6115AC6T1
MP3H6115AC6U
MPXA6115A6T1
MPXA6115A6U
MPXA6115AC6T1
MPXA6115AC6U
MPXA6115AC7U
MPXAZ6115A6U
MPXAZ6115AC6T1
MPXAZ6115AC6U
MPXAZ6115AP
MPXAZ6115APT1
MPXH6115A6T1
MPXH6115A6U
MPXH6115AC6T1
MPXH6115AC6U
MPXHZ6115A6T1
MPXHZ6115A6U
MPXHZ6115AC6T1
MPXHZ6115AC6U
MPXV6115VC6T1
MPXV6115VC6U
MPXHZ6130A6U
MPXHZ6130AC6U
MPXVZ5150GC6T1
MPXVZ5150GC7U
MPX4200A
MPXH6250A6T1

MPXH6250A6U
MPXH6250AC6T1
MPXH6250AC6U
MPXHZ6250A6T1
MPXHZ6250A6U
MPXHZ6250AC6T1
MPXH6300A6T1
MPXH6300A6U
MPXH6300AC6T1
MPXH6300AC6U
MPXH6400AC6T1
MPXH6400AC6U
MPXHZ6400AC6T1
MPX4250A
MPX4250AP
MPX4250D
MPX4250DP
MPX4250GP
MPXA4250A6U
MPXA4250AC6T1
MPXA4250AC6U
MPXAZ4250AC6T1
MPX5500D
MPX5500DP
MPX5700A
MPX5700AP
MPX5700AS
MPX5700D
MPX5700DP
MPX5700GP
MPX5700GS
MPX5999D
MPXY8300A6T1
MPXY8300A6U
MPXY8300B6T1
MPXY8300B6U
MPXY8300C6T1
MPXY8300C6U

MPXY8310A6T1
MPXY8310A6U
MPXY8310B6T1
MPXY8310B6U
MPXY8310C6T1
MPXY8310C6U
MPXY8320A6T1
MPXY8320A6U
MPXY8320B6T1
MPXY8320B6U
MPXY8320C6T1
MPXY8320C6U

Compensated

MPX2300DT1
MPX2301DT1
MPX2010D
MPX2010DP
MPX2010GP
MPX2010GS
MPX2010GSX
MPXM2010D
MPXM2010DT1
MPXM2010GS
MPXM2010GST1
MPXV2010DP
MPXV2010GP
MPXC2011DT1
MPXC2012DT1
MPX2050D
MPX2050DP
MPX2050GP
MPX2050GSX
MPXM2051GS
MPXM2051GST1
MPX2053D
MPX2053DP
MPX2053GP
MPXM2053D
MPXM2053DT1

MPXM2053GS
MPXM2053GST1
MPXV2053DP
MPXV2053GP
MPXV2053GVP
MPX2100A
MPX2100AP
MPX2100ASX
MPX2100D
MPX2100DP
MPX2100GP
MPX2100GVP
MPX2102A
MPX2102AP
MPX2102ASX
MPX2102DP
MPX2102GP
MPX2102GVP
MPXM2102A
MPXM2102AS
MPXM2102AST1
MPXM2102AT1
MPXM2102GS
MPXM2102GST1
MPXV2102GP
MPX2200A
MPX2200AP
MPX2200D
MPX2200DP
MPX2200GP
MPX2202A
MPX2202AP
MPX2202ASX
MPX2202DP
MPX2202GP
MPXM2202A
MPXM2202AS
MPXM2202D
MPXM2202DT1
MPXM2202GS

MPXM2202GST1
MPXV2202DP
MPXV2202GC6T1
MPXV2202GC6U
MPXV2202GP

Uncompensated

MPX10D
MPX10DP
MPX10GP
MPXV10GC6U
MPXV10GC7U
MPX12D
MPX12DP
MPX12GP
MPX12GW6U
MPX12GW7U
MPX53D
MPX53DP
MPXV53GC7U
MPX53GP

Legend

Digital Pressure Sensors
Integrated
Compensated
Uncompensated

A change bar appears in the left margin to mark the location of new or revised information.

How to Reach Us:

Home Page:

www.freescale.com

Web Support:

<http://www.freescale.com/support>

USA/Europe or Locations Not Listed:

Freescale Semiconductor, Inc.
Technical Information Center, EL516
2100 East Elliot Road
Tempe, Arizona 85284
1-800-521-6274 or +1-480-768-2130
www.freescale.com/support

Europe, Middle East, and Africa:

Freescale Halbleiter Deutschland GmbH
Technical Information Center
Schatzbogen 7
81829 Muenchen, Germany
+44 1296 380 456 (English)
+46 8 52200080 (English)
+49 89 92103 559 (German)
+33 1 69 35 48 48 (French)
www.freescale.com/support

Japan:

Freescale Semiconductor Japan Ltd.
Headquarters
ARCO Tower 15F
1-8-1, Shimo-Meguro, Meguro-ku,
Tokyo 153-0064
Japan
0120 191014 or +81 3 5437 9125
support.japan@freescale.com

Asia/Pacific:

Freescale Semiconductor China Ltd.
Exchange Building 23F
No. 118 Jianguo Road
Chaoyang District
Beijing 100022
China
+86 10 5879 8000
support.asia@freescale.com

For Literature Requests Only:

Freescale Semiconductor Literature Distribution Center
1-800-441-2447 or +1-303-675-2140
Fax: +1-303-675-2150
LDCForFreescaleSemiconductor@hibbertgroup.com

Information in this document is provided solely to enable system and software implementers to use Freescale Semiconductor products. There are no express or implied copyright licenses granted hereunder to design or fabricate any integrated circuits or integrated circuits based on the information in this document.

Freescale Semiconductor reserves the right to make changes without further notice to any products herein. Freescale Semiconductor makes no warranty, representation or guarantee regarding the suitability of its products for any particular purpose, nor does Freescale Semiconductor assume any liability arising out of the application or use of any product or circuit, and specifically disclaims any and all liability, including without limitation consequential or incidental damages. "Typical" parameters that may be provided in Freescale Semiconductor data sheets and/or specifications can and do vary in different applications and actual performance may vary over time. All operating parameters, including "Typicals", must be validated for each customer application by customer's technical experts. Freescale Semiconductor does not convey any license under its patent rights nor the rights of others. Freescale Semiconductor products are not designed, intended, or authorized for use as components in systems intended for surgical implant into the body, or other applications intended to support or sustain life, or for any other application in which the failure of the Freescale Semiconductor product could create a situation where personal injury or death may occur. Should Buyer purchase or use Freescale Semiconductor products for any such unintended or unauthorized application, Buyer shall indemnify and hold Freescale Semiconductor and its officers, employees, subsidiaries, affiliates, and distributors harmless against all claims, costs, damages, and expenses, and reasonable attorney fees arising out of, directly or indirectly, any claim of personal injury or death associated with such unintended or unauthorized use, even if such claim alleges that Freescale Semiconductor was negligent regarding the design or manufacture of the part.