



MOTOROLA
Semiconductor Products Sector

SG379/D
REV 7

NORTH AMERICA SALES AND DISTRIBUTION PRICE LIST

THIS BOOK IS IN COMPUTER SORT
PRODUCT CLASSIFICATION - Please see General Information Section 1.3

EFFECTIVE DATE:
JANUARY 10, 1998

Datasheet.Live

General Information **1**

Cross References **2**

Pull Through Chart **3**

Development Systems **4**

Blue Chip Program **5**

Commercial Component and Development Systems Pricing **6**

General Information

- Elimination Of Ozone Depleting Chemicals . . . 1-2 (Rev. July 97)
- Motorola Distributor
 - Product Classifications 1-3 (Rev. July 97)
- Motorola Sales Offices & Representatives . . . 1-4 (Rev. Jan. 98)
- Motorola Standard Policies & Disclaimers . . . 1-5 (Rev. Jan. 96)
- Indemnification Form 1-6 (Rev. Jan. 94)
- Pricing and Ordering Information 1-7 (Rev. Jan. 94)
- Using Computer Sort
 - Finding Devices Easily In This Book 1-8 (Rev. Jan. 96)



ELIMINATION OF OZONE DEPLETING CHEMICALS

Motorola Semiconductor Products Sector has been asked by many of its customers to report on its usage of ozone depleting substances in its manufacture of products with respect to the new federal labeling requirements under the 1990 Clean Air Act amendments.

As of May 1993, Motorola SPS meets the conditions of the EPA Final Rule defining labeling requirements. The products currently manufactured by Motorola SPS will be free of labeling, as well as those that we manufacture in the future.

Motorola began its worldwide elimination program early in the process and is pleased that we met the goal ahead of the EPA's schedule. The protection of the environment, including the ozone layer, continues to be a major interest of Motorola SPS.

If you should have any questions or concerns about CFC's or other ozone depleting substances, or about environmental topics in general, please let us know.



MOTOROLA DISTRIBUTOR PRODUCT CLASSIFICATIONS

1

<u>CLASSIFICATION:</u>	<u>DESCRIPTION:</u>
1	<p>“Class One” Device A mature, stable, high-volume Motorola Device with a broad customer base.</p>
2	<p>“Class Two” Device A moderate-volume or high-volume Motorola Device with possible market volatility.</p>
3	<p>“Class Three” Device A low-volume Motorola Device on declining side of its Product Lifecycle available ONLY through a Motorola designated Class 3 catalog distributor. A Class 3 designation does not mean that Motorola has discontinued the device.</p>
N	<p>“Class N” Device A Motorola Device introduced within the last two years requiring Sales and Marketing Design-In effort.</p>
R	<p>“Class R” Device A key “focus” Motorola Device that requires Distributor inventory stocking.</p>

Below is a summary matrix of how this terminology applies to each Product Class:

<u>CLASS:</u>	<u>PREFERRED CLASS:</u>
1	Y
2	Y
N	Y
R	Y
3	N
NON BOOK	N



SALES OFFICES**UNITED STATES**

ALABAMA	
Huntsville	(205)464-6800
ALASKA	(800)635-8291
ARIZONA	
Phoenix	(602)302-8056
CALIFORNIA	
Calabasas	(818)878-6800
Irvine	(714)753-7360
Los Angeles	(818)878-6800
San Diego	(619)541-2163
Sunnyvale	(408)749-0510
COLORADO	
Denver	(303)337-3434
CONNECTICUT	
Wallingford	(203)949-4100
FLORIDA	
Clearwater	(813)524-4177
Maitland	(407)628-2636
Pompano Beach/Ft. Lauderdale	(954)351-6040
GEORGIA	
Atlanta	(770)729-7100
IDAHO	
Boise	(208)323-9413
ILLINOIS	
Chicago/Schaumburg	(847)413-2500
INDIANA	
Indianapolis	(317)571-0400
Kokomo	(765)455-5100
IOWA	
Cedar Rapids	(319)378-0383
KANSAS	
Kansas City/Mission	(913)451-8555
MARYLAND	
Columbia	(410)381-1570
MASSACHUSETTS	
Marlborough	(508)357-8207
Woburn	(781)932-9700
MICHIGAN	
Detroit	(248)347-6800
MINNESOTA	
Mnetonka	(612)932-1500
MISSOURI	
St. Louis	(314)275-7380
NEW JERSEY	
Fairfield	(973)808-2400
NEW YORK	
Fairport	(716)425-4000
Fishkill	(914)896-0511
Hauppauge	(516)361-7000
NORTH CAROLINA	
Raleigh	(919)870-4355
OHIO	
Cleveland	(440)349-3100
Columbus/Worthington	(614)431-8492
Dayton	(937)438-6800
OKLAHOMA	
Tulsa	(918)251-3414
or	(918)258-0933
OREGON	
Portland	(503)641-3681
PENNSYLVANIA	
Colmar	(215)997-1020
Philadelphia/Horsham	(215)957-4100
TENNESSEE	
Knoxville	(423)584-4841
TEXAS	
Austin	(512)502-2100
Houston	(713)251-0006
Plano	(972)516-5100

VIRGINIA

Richmond (804)285-2100

WASHINGTONBellevue (425)454-4160
Seattle (toll free) (206)622-9960**WISCONSIN**

Milwaukee/Brookfield (414)792-0122

Field Applications Engineering Available
Through All Sales Offices**CANADA****BRITISH COLUMBIA**

Vancouver (604)606-8502

ONTARIOOttawa (613)226-3491
Mississauga (905)501-3500**QUEBEC**

Montreal (514)333-3300

INTERNATIONAL**AUSTRALIA**Melbourne (61-3)98870711
Sydney (61-2)99661071**BRAZIL**

Sao Paulo 55(011)3030-5244

CHINABeijing 86-10-68437222
Guangzhou 86-20-87537888
Shanghai 86-21-63747668
Tianjin 86-22-25325072**CZECH REPUBLIC**

(420) 2 21852222

FINLANDHelsinki (358) 9 6824 400
Direct Sales Lines (358) 9 6824 4044
(358) 9 6824 4045**FRANCE**

Paris 33134 635900

GERMANYLangenhagen/Hanover 49(511)786880
Munich 49 89 92103-0
Nuremberg 49 911 96-3190
Sindelfingen 49 7031 79 710
Wiesbaden 49 611 973050**HONG KONG**Kwai Fong 852-2-610-6888
Tai Po 852-2-666-8333**HUNGARY**

(36) 1 250 83 29

INDIA

Bangalore 91-80-5598615

ISRAEL

Herzlia 972-9-9522333

ITALY

Milan 39(2)82201

JAPANKyusyu 81-92-725-7583
Gotanda 81-3-5487-8311
Nagoya 81-52-232-3500
Osaka 81-6-305-1801
Sendai 81-22-268-4333
Takamatsu 81-878-37-9972
Tokyo 81-3-3440-3311**KOREA**Pusan 82(51)4635-035
Seoul 82-2-3440-7200**MALAYSIA**

Penang 60(4)228-2514

MEXICOChihuahua 52(14)39-3120
Mexico City 52(5)282-0230
Guadalajara 52(36)78-0750
Zapopan Jalisco 52(36)78-0750
Marketing 52(36)21-2023
Customer Service 52(36)669-9160**NETHERLANDS**

Best (31)4993 612 11

PHILIPPINES

Manila (63)2 822-0625

POLAND

(48) 34 27 55 75

PUERTO RICO

Rio Piedras (787)282-2300

RUSSIA

(7) 095 929 90 25

SCOTLAND

East Kilbride (44)1355 565447

SINGAPORE

(65)4818188

SPAIN

Madrid 34(1)457-8204

SWEDEN

Solna 46(8)734-8800

SWITZERLANDGeneva 41(22)799 11 11
Zurich 41(1)730-4074**TAIWAN**

Taipei 886(2)717-7089

THAILAND

Bangkok 66(2)254-4910

TURKEY

(90) 212 274 66 48

UNITED KINGDOM

Aylesbury 44 1 (296)395252

NORTH AMERICA**FULL LINE REPRESENTATIVES****ARIZONA, Tempe**

S&S Technologies, Inc. (602)414-1100

CALIFORNIA, Loomis

Galena Technology Group (916)652-0268

INDIANA, Indianapolis

Bailey's Electronics (317)848-9958

NEVADA, Clark County

S&S Technologies, Inc. (602)414-1100

NEVADA, Reno

Galena Tech. Group (702)746-0642

NEW MEXICO, Albuquerque

S&S Technologies, Inc. (505)414-1100

TEXAS, El Paso

S&S Technologies, Inc. (915)833-5461

UTAH, Salt Lake City

Utah Comp. Sales, Inc. (801)572-4010

WASHINGTON, Spokane

Doug Kenley (509)924-2322

NORTH AMERICA**HYBRID/MCM COMPONENT SUPPLIERS**Chip Supply (407)298-7100
Elmo Semiconductor (818)768-7400
Minco Technology Labs Inc. (512)834-2022
Semi Dice Inc. (310)594-4631

MOTOROLA STANDARD POLICIES & DISCLAIMERS

1

Motorola reserves the right to make changes without further notice to any products herein. Motorola makes no warranty, representation or guarantee regarding the suitability of its products for any particular purpose, nor does Motorola assume any liability arising out of the application or use of any product or circuit, and specifically disclaims any and all liability, including without limitation consequential or incidental damages.

“Typical” parameters which may be provided in Motorola data sheets and/or specifications can and do vary in different applications and actual performance may vary over time. All operating parameters, including “Typicals” must be validated for each customer application by customer’s technical experts.

Motorola does not convey any license under its patent rights nor the rights of others.

Motorola and  are registered trademarks of Motorola, Inc. Motorola, Inc. is an Equal Opportunity/Affirmative Action Employer.

MOTOROLA PRODUCT SAFETY POLICY

OEM POLICY

Motorola products are not designed, intended, nor authorized for use as components in systems intended for surgical implant into the body, or in other applications intended to support or sustain life, or in any other application in which the failure of the Motorola product could create a situation where personal injury or death may occur. Should Buyer purchase or use Motorola products for any such unintended or unauthorized application, Buyer shall indemnify* and hold Motorola and its officers, employees, subsidiaries, affiliates, and distributors harmless against all claims, costs, damages, and expenses, and reasonable attorney fees arising out of, directly or indirectly, any claim of personal injury or death associated with such unintended or unauthorized use, even if such claim alleges that Motorola was negligent regarding the design or manufacture of the product.

DISTRIBUTOR POLICY

Motorola products are not designed, intended, nor authorized for use as components in systems intended for surgical implant into the body, or in other applications intended to support or sustain life, or in any other application in which the failure of the Motorola product could create a situation where personal injury or death may occur.

Motorola periodically may inform Distributor that certain customers have sought and been denied permission to purchase certain Motorola products for such uses directly from Motorola. Distributor agrees, upon being so informed, to take reasonable action to prevent sales of the Motorola products in question for such uses to any such identified customers.

Distributor further agrees, before any sale of Motorola products made with actual knowledge that the customer is purchasing for such use, to inform Motorola of the potential sale. In the event Motorola, in its sole discretion, determines that it does not want its product sold for such use, Distributor agrees that it will not sell the product or any substitute Motorola products to the customer for such use.

If Distributor makes the sale despite Motorola’s instruction to the contrary, Distributor agrees to indemnify* and hold Motorola, and its officers, employees, subsidiaries, affiliates, and distributors harmless against all claims, costs, damages, and expenses, and reasonable attorney fees arising out of, directly or indirectly, any claim of personal injury or death associated with such unauthorized use, even if such claim alleges that Motorola was negligent regarding the design or manufacture of the product.

* NOTE: A copy of the standard Motorola indemnity form is on the following page.



INDEMNIFICATION FORM

Motorola, Inc. ("Motorola"), and _____ ("Customer") hereby agree to the following in regard to all purchases of Motorola semiconductor products by customer from whatever source:

1. Customer hereby agrees to indemnify, defend, and hold harmless Motorola, and all of its officers, directors, subsidiaries, affiliates, agents, and/or employees (the "Indemnitees"), from and against any and all claims, demands, judgments, and lawsuits for personal injury or death or property damage arising out of or associated in any manner with the incorporation in any of Customer's devices, systems, or products of a device, die, component, part, or assembly ("Products") manufactured and/or sold by Motorola or any of its subsidiaries, affiliates, or distributors, and any and all losses, costs, damages, and expenses (including reasonable attorneys' fees) incurred by the Indemnitees or any of them in connection with such a claim, demand, judgment, or lawsuit; provided, however, that:
 - (a) Customer is provided with prompt notice after Motorola learns of any such claim, demand, or lawsuit;
 - (b) The Indemnitees cooperate fully with Customer in the defense of such claim, demand, or lawsuit; and
 - (c) Customer has the exclusive control over the defense and settlement of any such claim, demand, or lawsuit.

2. The foregoing indemnity is agreed by the parties hereto to apply to any and all claims of whatever nature against the Indemnitees, including expressly, but not limited to, claims that any of the Indemnitees were negligent, jointly or collectively, whether actively or passively, regarding any acts or omissions in connection with the design, manufacture, and/or sale of Motorola's Semiconductor Products, or claims that Motorola's Semiconductor Products were defective or dangerous in design or manufacture or would otherwise subject any of the Indemnitees to liability on any strict liability theory, **except only claims arising from Motorola's willful misconduct.**

IN WITNESS WHEREOF, the parties hereto have caused their duly authorized officers to execute this Indemnity as of the date indicated.

MOTOROLA, INC.

CUSTOMER

By: (Signature) _____

By: (Signature) _____

Title: _____

Title: _____

Date: _____

Date: _____

Address: _____

Address: _____



PRICING AND ORDERING INFORMATION

1

PRICING POLICY

All prices listed herein are in U.S. dollars. These prices supersede all previously issued prices and are subject to change or withdrawal without notice.

MINIMUM ORDER REQUIREMENTS

- All orders placed directly with Motorola must be in multiples of the "Factory Order Increment" quantity specified for that device. Orders placed with Motorola authorized distributors should be in multiples of the "Suggested Resale" column quantity to minimize handling-induced quality problems and administrative errors.
- The minimum acceptable line item (scheduled release) for orders placed on Motorola is \$200 in multiples of the "Factory Order Increment" quantity, unless otherwise noted.

Note: These minimums do not apply to literature or samples.

CHANGE ORDER & CANCELLATION REQUIREMENTS

- Thirty-five (35) days' notice, prior to the MSD (Motorola Schedule Date), is required for all standard commercial price book device order changes and/or cancellations. The starting date is the date of formal notification to the appropriate Motorola order entry location.

Note: Specials, non-book devices, or price book devices on allocation require sixty-five (65) days' notice.

- Customers and authorized distributors on EDI for change orders and cancellations may be authorized to reduce the above notification requirements by five (5) days.

RETURNS

The customer must obtain advance authorization for the return of any product from the responsible Motorola Salesperson or Authorized Distributor. At the time such authorization is granted, the customer will be informed of the return procedure to be followed. In all cases, such products are to be returned FOB destination, normally by parcel post. Any replacement by the Company will also be FOB destination, normally by parcel post.

Product must be properly packaged in Motorola containers to be in saleable condition and to prevent electrical and mechanical damage. Except as noted below no returns will be accepted, unless the device is packaged in complete original primary containers. For devices shipped in the sealed "drypack" desiccant bags, no returns will be accepted unless the original factory seal is unbroken and the bag is intact. Tape and reel devices must be on Motorola reels and must have the original seal and lead tape intact. There must be no writing or marking on any labels.

Note: These requirements do not apply to quality returns (including distributor returns for date code expiration), or to distributor returns due to price book deletion or devices being moved to Class 3.

Designer's, EPI-BASE, Epicap, MDTL, MECL, MECL 10,000, MECL III, MHTL, MTTL, Multi-Pak, QUIL, Surmetic, SWITCHMODE, Thermopad, and Uniwatt are trademarks of Motorola, Inc.

Annular Semiconductors and Field Relief Electrode are patented by Motorola, Inc.



USING COMPUTER SORT

FINDING DEVICES EASILY IN THIS PRICE BOOK

As indicated on the front cover of this Price Book all devices listed are in "Computer Sort".

All devices listed in this book follow a 39 character alphabet. This "new" alphabet starts with a period, a dash and a slash (. - /), followed by the 26 letter alphabet (A thru Z), which is then followed by 10 numbers (0 thru 9).

The ranking or hierarchy of this 39 character alphabet is as follows:

. - / A B C D E F G H I J K L M N O P Q R S T U V W X Y Z 0 1 2 3 4 5 6 7 8 9

Therefore, if you are looking for a device starting with a letter of the alphabet like an MC1741CP, it would appear before a device starting with a number, such as 2N1132.

TO FIND A DEVICE IN THIS PRICE BOOK:

Start with the first character of the device and find that section of the price book that corresponds to this character (i.e. a Slash (/), an "M" or a "2"); next move to the second character in the device number, and move to that character within the same portion of the listing; and so on until the device number is found. In other words it is used just like a dictionary, character by character.

EXAMPLE:

To find the 2N6837, go to that section of the listing that begins with the Number "2" (Notice that the section follows all devices that begin with a letter of the alphabet or "1"). Next, find that portion of the listing that begins with "2N" (Notice it follows those devices that begin with "2K".) Next, find that portion of the listing that begins with "2N6". (Notice it follows those devices that begin with "2N5".) Continue looking for those portions that begin with the next consecutive character until you have found the entire number.

IMPORTANT

Because of the way "computer sort" works it is not necessary to be concerned with the absolute value or number of characters in a part number, just move across the device part number, left to right, one character at a time until you find the number.



Cross References

Signal Products
Through-Hole To Surface Mount 2-3 (Rev. July 97)
FPGA Cross Reference 2-5 (Rev. Jan. 94)

2







MOTOROLA

SIGNAL PRODUCTS THROUGH-HOLE TO SURFACE MOUNT CROSS REFERENCE

2

THROUGH-HOLE	SURFACE MOUNT	THROUGH-HOLE	SURFACE MOUNT	THROUGH-HOLE	SURFACE MOUNT
1N914	MMBD914LT1	1N5270B	MMBZ5170BL	1N6272A	1.5SMC11AT3
1N5221B	MMBZ5221BLT1	1N5913B	1SMB5913BT3	1N6273A	1.5SMC12AT3
1N5222B	MMBZ5222BLT1	1N5914B	1SMB5914BT3	1N6274A	1.5SMC13AT3
1N5223B	MMBZ5223BLT1	1N5915B	1SMB5915BT3	1N6275A	1.5SMC15AT3
1N5224B	MMBZ5224BLT1	1N5916B	1SMB5916BT3	1N6276A	1.5SMC16AT3
1N5225B	MMBZ5225BLT1	1N5917B	1SMB5917BT3	1N6277A	1.5SMC18AT3
1N5226B	MMBZ5226BLT1	1N5918B	1SMB5918BT3	1N6278A	1.5SMC20AT3
1N5227B	MMBZ5227BLT1	1N5919B	1SMB5919BT3	1N6279A	1.5SMC22AT3
1N5228B	MMBZ5228BLT1	1N5920B	1SMB5920BT3	1N6280A	1.5SMC24AT3
1N5229B	MMBZ5229BLT1	1N5921B	1SMB5921BT3	1N6281A	1.5SMC27AT3
1N5230B	MMBZ5230BLT1	1N5922B	1SMB5922BT3	1N6282A	1.5SMC30AT3
1N5231B	MMBZ5231BLT1	1N5923B	1SMB5923BT3	1N6283A	1.5SMC33AT3
1N5232B	MMBZ5232BLT1	1N5924B	1SMB5924BT3	1N6284A	1.5SMC36AT3
1N5233B	MMBZ5233BLT1	1N5925B	1SMB5925BT3	1N6285A	1.5SMC39AT3
1N5234B	MMBZ5234BLT1	1N5926B	1SMB5926BT3	1N6286A	1.5SMC43AT3
1N5235B	MMBZ5235BLT1	1N5927B	1SMB5927BT3	1N6287A	1.5SMC47AT3
1N5236B	MMBZ5236BLT1	1N5928B	1SMB5928BT3	1N6288A	1.5SMC51AT3
1N5237B	MMBZ5237BLT1	1N5929B	1SMB5929BT3	1N6289A	1.5SMC56AT3
1N5238B	MMBZ5238BLT1	1N5930B	1SMB5930BT3	1N6290A	1.5SMC62AT3
1N5239B	MMBZ5239BLT1	1N5931B	1SMB5931BT3	1N6291A	1.5SMC68AT3
1N5240B	MMBZ5240BLT1	1N5932B	1SMB5932BT3	1N6292A	1.5SMC75AT3
1N5241B	MMBZ5241BLT1	1N5933B	1SMB5933BT3	1N6293A	1.5SMC82AT3
1N5242B	MMBZ5242BLT1	1N5934B	1SMB5934BT3	1N6294A	1.5SMC91AT3
1N5243B	MMBZ5243BLT1	1N5935B	1SMB5935BT3	1.5KE6.8A	1.5SMC6.8AT3
1N5244B	MMBZ5244BLT1	1N5936B	1SMB5936BT3	1.5KE7.5A	1.5SMC7.5AT3
1N5245B	MMBZ5245BLT1	1N5937B	1SMB5937BT3	1.5KE8.2A	1.5SMC8.2AT3
1N5246B	MMBZ5246BLT1	1N5938B	1SMB5938BT3	1.5KE9.1A	1.5SMC9.1AT3
1N5247B	MMBZ5247BLT1	1N5939B	1SMB5939BT3	1.5KE10A	1.5SMC10AT3
1N5248B	MMBZ5248BLT1	1N5940B	1SMB5940BT3	1.5KE11A	1.5SMC11AT3
1N5249B	MMBZ5249BLT1	1N5941B	1SMB5941BT3	1.5KE12A	1.5SMC12AT3
1N5250B	MMBZ5250BLT1	1N5942B	1SMB5942BT3	1.5KE13A	1.5SMC13AT3
1N5251B	MMBZ5251BLT1	1N5943B	1SMB5943BT3	1.5KE15A	1.5SMC15AT3
1N5252B	MMBZ5252BLT1	1N5944B	1SMB5944BT3	1.5KE16A	1.5SMC16AT3
1N5253B	MMBZ5253BLT1	1N5945B	1SMB5945BT3	1.5KE18A	1.5SMC18AT3
1N5254B	MMBZ5254BLT1	1N5946B	1SMB5946BT3	1.5KE20A	1.5SMC20AT3
1N5255B	MMBZ5255BLT1	1N5947B	1SMB5947BT3	1.5KE22A	1.5SMC22AT3
1N5256B	MMBZ5256BLT1	1N5948B	1SMB5948BT3	1.5KE24A	1.5SMC24AT3
1N5257B	MMBZ5257BLT1	1N5949B	1SMB5949BT3	1.5KE27A	1.5SMC27AT3
1N5258B	MMBZ5258BLT1	1N5950B	1SMB5950BT3	1.5KE30A	1.5SMC30AT3
1N5259B	MMBZ5259BLT1	1N5951B	1SMB5951BT3	1.5KE33A	1.5SMC33AT3
1N5260B	MMBZ5260BLT1	1N5952B	1SMB5952BT3	1.5KE36A	1.5SMC36AT3
1N5261B	MMBZ5261BLT1	1N5953B	1SMB5953BT3	1.5KE39A	1.5SMC39AT3
1N5262B	MMBZ5262BLT1	1N5954B	1SMB5954BT3	1.5KE43A	1.5SMC43AT3
1N5263B	MMBZ5263BLT1	1N5955B	1SMB5955BT3	1.5KE47A	1.5SMC47AT3
1N5264B	MMBZ5264BLT1	1N5956B	1SMB5956BT3	1.5KE51A	1.5SMC51AT3
1N5265B	MMBZ5265BLT1	1N6267A	1.5SMC6.8AT3	1.5KE56A	1.5SMC56AT3
1N5266B	MMBZ5266BLT1	1N6268A	1.5SMC7.5AT3	1.5KE62A	1.5SMC62AT3
1N5267B	MMBZ5267BLT1	1N6269A	1.5SMC8.2AT3	1.5KE68A	1.5SMC68AT3
1N5268B	MMBZ5268BLT1	1N6270A	1.5SMC9.1AT3	1.5KE75A	1.5SMC75AT3
1N5269B	MMBZ5269BLT1	1N6271A	1.5SMC10AT3	1.5KE82A	1.5SMC82AT3



THROUGH-HOLE	SURFACE MOUNT	THROUGH-HOLE	SURFACE MOUNT	THROUGH-HOLE	SURFACE MOUNT
1.5KE91A	1.5SMC91AT3	MPSA06	MMBTA06LT1	SA7.0A	1SMB7.0AT3
2N2222	MMBT2222LT1	MPSA13	MMBTA13LT1	SA7.5A	1SMB7.5AT3
2N2222A	MMBT2222ALT1	MPSA14	MMBTA14LT1	SA8.0A	1SMB8.0AT3
2N2369	MMBT2369LT1	MPSA20	MMBTA20LT1	SA8.5A	1SMB8.5AT3
2N2369A	MMBT2369ALT1	MPSA42	MMBTA42LT1	SA9.0A	1SMB9.0AT3
2N2484	MMBT2484LT1	MPSA43	MMBTA43LT1	SA10A	1SMB10AT3
2N2907	MMBT2907LT1	MPSA55	MMBTA55LT1	SA11A	1SMB11AT3
2N2907A	MMBT2907ALT1	MPSA56	MMBTA56LT1	SA12A	1SMB12AT3
2N3904	MMBT3904LT1	MPSA63	MMBTA63LT1	SA13A	1SMB13AT3
2N3906	MMBT3906LT1	MPSA64	MMBTA64LT1	SA14A	1SMB14AT3
2N4401	MMBT4401LT1	MPSA70	MMBTA70LT1	SA15A	1SMB15AT3
2N4403	MMBT4403LT1	MPSA92	MMBTA92LT1	SA16A	1SMB16AT3
2N5087	MMBT5087LT1	MPSA93	MMBTA93LT1	SA17A	1SMB17AT3
2N5088	MMBT5088LT1	MPSH10	MMBTH10LT1	SA18A	1SMB18AT3
2N5089	MMBT5089LT1	MPSH81	MMBTH81LT1	SA20A	1SMB20AT3
2N5401	MMBT5401LT1	MV409	MMBV409LT1	SA22A	1SMB22AT3
2N5457	MMBF5457LT1	MV2101	MMBV2101LT1	SA24A	1SMB24AT3
2N5459	MMBF5459LT1	MV2105	MMBV2105LT1	SA26A	1SMB26AT3
2N5460	MMBF5460LT1	MV2107	MMBV2107LT1	SA28A	1SMB28AT3
2N5484	MMBF5484LT1	MV2108	MMBV2108LT1	SA30A	1SMB30AT3
2N5486	MMBF5486LT1	MV2109	MMBV2109LT1	SA33A	1SMB33AT3
2N5550	MMBT5550LT1	PN2222A	MMBT2222ALT1	SA36A	1SMB36AT3
2N5551	MMBT5551LT1	PN2907A	MMBT2907ALT1	SA40A	1SMB40AT3
2N6427	MMBT6427LT1	P6KE6.8A	P6SMB6.8AT3	SA43A	1SMB43AT3
2N6517	MMBT6517LT1	P6KE7.5A	P6SMB7.5AT3	SA45A	1SMB45AT3
2N6520	MMBT6520LT1	P6KE8.2A	P6SMB8.2AT3	SA48A	1SMB48AT3
BS107	MMFT107T1	P6KE9.1A	P6SMB9.1AT3	SA51A	1SMB51AT3
BS170	MMBF170LT1	P6KE10A	P6SMB10AT3	SA54A	1SMB54AT3
J309	MMBFJ309LT1	P6KE11A	P6SMB11AT3	SA58A	1SMB58AT3
J310	MMBFJ310LT1	P6KE12A	P6SMB12AT3	SA60A	1SMB60AT3
MAD130P	MMAD130	P6KE13A	P6SMB13AT3	SA64A	1SMB64AT3
MAD1103P	MMAD1103	P6KE15A	P6SMB15AT3	SA70A	1SMB70AT3
MAD1107P	MMAD1107	P6KE16A	P6SMB16AT3	SA90A	1SMB90AT3
MAD1108P	MMAD1108	P6KE18A	P6SMB18AT3	SA100A	1SMB100AT3
MAD1109P	MMAD1109	P6KE20A	P6SMB20AT3	SA110A	1SMB110AT3
MBD101	MMBD101LT1	P6KE22A	P6SMB22AT3	SA120A	1SMB120AT3
MBD301	MMBD301LT1	P6KE24A	P6SMB24AT3	SA130A	1SMB130AT3
MBD701	MMBD701LT1	P6KE27A	P6SMB27AT3	SA150A	1SMB150AT3
MPF6661	MMFT6661LT1	P6KE30A	P6SMB30AT3	SA160A	1SMB160AT3
MPN3700	MMBV3700LT1	P6KE33A	P6SMB33AT3	SA170A	1SMB170AT3
MPQ2222	MMMQ2222	P6KE36A	P6SMB36AT3		
MPQ2222A	MMMQ2222A	P6KE39A	P6SMB39AT3		
MPQ2369	MMMQ2369	P6KE43A	P6SMB43AT3		
MPQ2907	MMMQ2907	P6KE47A	P6SMB47AT3		
MPQ2907A	MMMQ2907A	P6KE51A	P6SMB51AT3		
MPQ3467	MMMQ3467	P6KE56A	P6SMB56AT3		
MPQ3725	MMMQ3725	P6KE62A	P6SMB62AT3		
MPQ3904	MMMQ3904	P6KE68A	P6SMB68AT3		
MPQ3906	MMMQ3906	P6KE75A	P6SMB75AT3		
MPQ6700	MMMQ6700	P6KE82A	P6SMB82AT3		
MPQ6842	MMMQ6842	P6KE91A	P6SMB91AT3		
MPS404A	MMBT404ALT1	P6KE100A	P6SMB100AT3		
MPS918	MMBT918LT1	P6KE110A	P6SMB110AT3		
MPS2222	MMBT2222LT1	P6KE120A	P6SMB120AT3		
MPS2222A	MMBT2222ALT1	P6KE130A	P6SMB130AT3		
MPS2369	MMBT2369LT1	P6KE150A	P6SMB150AT3		
MPS2369A	MMBT2369ALT1	P6KE160A	P6SMB160AT3		
MPS2907	MMBT2907LT1	P6KE170A	P6SMB170AT3		
MPS2907A	MMBT2907ALT1	P6KE180A	P6SMB180AT3		
MPS3640	MMBT3640LT1	P6KE200A	P6SMB200AT3		
MPS3904	MMBT3904LT1	SA5.0A	1SMB5.0AT3		
MPS3906	MMBT3906LT1	SA6.0A	1SMB6.0AT3		
MPSA05	MMBTA05LT1	SA6.5A	1SMB6.5AT3		



FPGA CROSS REFERENCE

MOTOROLA MPA1000	Actel			Altera	Atmel	AT&T		Xilinx	
1016	1010B 1020B	1225A 1240A	1415A 1425A 1440A	8282A 8452A	6002 6003	3030 3042	1C03	3142	4003
1036		1240A 1280A	1460A	8636A 8820A	6005	3064 3090	1C05 1C07	3164 3190 3195	4005 4006 4008 4010
1064			14100A	81188A 81500A	6010		2C12 2C15		4010 4013
1100				81500A			2C15 2C22		4025

2

MPA PART NUMBERING SYSTEMS

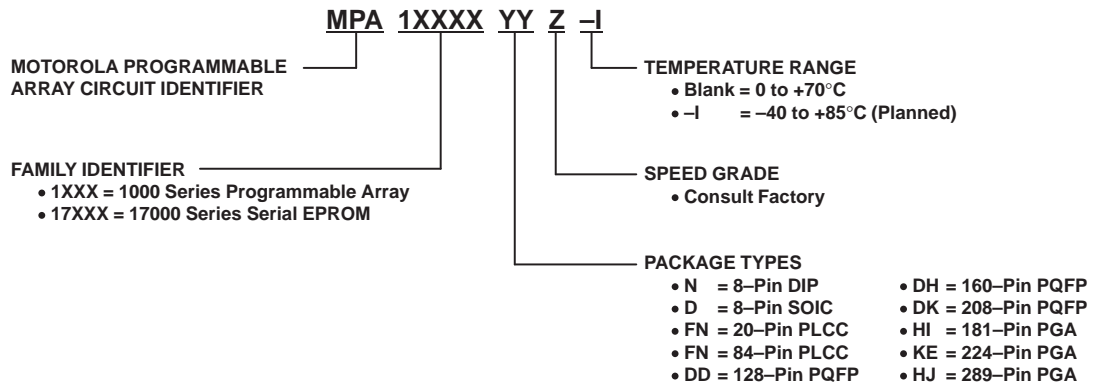

MPA DESIGN SYSTEM CONFIGURATION NUMBERING

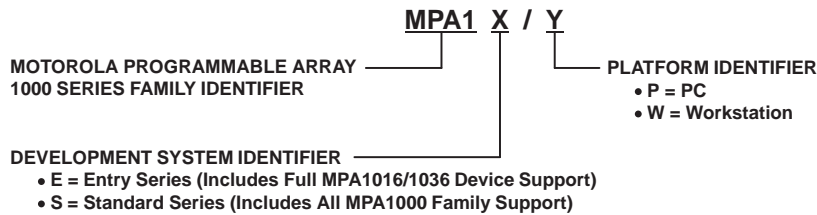

Pull Through Chart

Pull Through Chart 3-2 (Rev. Jan. 94)

3





PULL-THROUGH CHART

Motorola can also provide If these products are used in an applicaiton	MPU/MCU	MEMORIES	DEVELOPMENT SYSTEMS	MACROCELL ARRAY	LOGIC (STANDARD)	INTERFACE	TELECOM CIRCUITES	OP AMPS	REGULATORS	POWER TRANSISTORS	S.S. TRANSISTORS	FETS	SCR	TRIAC	TRIGGERS	RECTIFIERS	ZENERS	RF	OPTO PRODUCTS	SENSORS
MPU/MCU	X	X	X		X	X			X				X	X	X				X	X
MEMORIES	X	X		X	X	X														
DEVELOPMENT SYSTEMS	X		X																	
MACROCELL ARRAY	X	X		X	X								X	X	X				X	X
LOGIC (STANDARD)	X	X			X	X			X	X	X		X	X	X				X	X
INTERFACE		X				X	X		X											
TELECOM CIRCUITS						X	X	X		X	X									
OP AMPS								X		X	X	X								
REGULATORS					X				X	X							X	X		
POWER TRANSISTORS								X		X	X					X	X			
TRANSISTORS (S.S.)										X	X	X				X	X		X	X
FETS								X				X						X		
SCR	X				X								X	X	X	X	X		X	X
TRIAC	X				X								X	X	X	X	X		X	X
TRIGGERS													X	X	X					
RECTIFIERS									X	X	X					X	X			
ZENERS									X	X	X					X	X			
RF	X	X							X	X	X					X	X	X		
OPTO PRODUCTS	X	X										X	X	X	X				X	X
SENSORS	X	X				X		X		X	X	X	X	X					X	X

INSTRUCTIONS:

1. Convert the device to its Family — use the price book or Master Selection Guide.
2. Find the family in the left-hand column.
3. Move across to the right; when you find an "X", look at the device Family along the top. This is a family the customer is probably also using — remember to ask the customer about his or her needs in the other families.

Development Systems

DSP Development Systems	
– Suggestion/Problem Report Form	4-2 (Rev. Jan. 98)
NETCOMM Development	
– Systems Parts List	4-3 (Rev. Jan 98)
Imaging and Storage Division	
– Development Systems Parts List	4-4 (Rev. Jan. 98)
MPU/MCU Development Systems	
– Software License	4-5 (Rev. Jan. 94)
– Software License Agreement	4-6 (Rev. Jan. 94)
MCTG Development Tools Price Matrix	4-8 (Rev. July 97)
HC05	
– Direct Replacements	4-15 (Rev. July 97)



DSP SUGGESTION/PROBLEM REPORT

Motorola welcomes your comments on its DSP products and publications.
Please use this form.

TO: Motorola
Attn: Digital Signal Processors
Mail Drop: OE314
6501 William Cannon Dr., West
Austin, Texas 78735-8598

Product name(s): _____ Revision number(s): _____

Serial number(s): _____ Manual(s): _____

Please give a complete description below of the hardware configuration you are using, along with any comments or problems. This should include the type of host computer, software and any external circuitry you are using with this product. This information will be treated as confidential.

(For additional comments use other side)

Name: _____ Title: _____

Company: _____ Division: _____

Street: _____ Mail Drop: _____

City: _____ Phone: _____

State: _____ Zip: _____ Country: _____

Motorola Applications Support Services Hotline: (512) 895-3230
Fax #: (512) 895-3877



NETCOMM DEVELOPMENT SYSTEMS PARTS LIST

DEVICE	S/W CODE	RESALE	DESCRIPTION
M68SC302ADS		\$795	M68SC302 Application Development System Compatible with ISA and PCMCIA Card Slots
M68302ADI-PC		\$350	M68302FADS ADI Board for IBM PC
M68302ADI-SUN4		\$350	M68302ADI Board for SUN4, Not Compatible with Sparc 1 Machines
M68302FADS		\$995	M68302 Family Application Development System, comes with MC68302RC25
M68302FADS-ENA		\$200	Ethernet Adaptor Card, comes with MC68EN302RC25
M68302FADS-LC		\$995	M68302 Family Application Development System, comes with MC68LC302RC25
M68302FADS-PM		\$995	M68302 Family Application Development System, comes with MC68PM302RC25
M68302SWAUT-DOS		\$2,000	M68302 Microcode on MS-DOS 5.25" Diskette
M68302SWCEN-DOS		\$2,000	M68302 Centronics Parallel Interface on MS-DOS 5.25" Diskette
M302SWEDXUD-DOS		\$350	Latest Rev. of M68302SWEDX-DOS — must have original S/W
M302SWEDXUD-TAR		\$350	Latest Rev. of M68302SWEDX-TAR — must have original S/W
M302SWLBUD-DOS		\$350	Latest Rev. of M68302SWLB-DOS — must have original S/W
M302SWLBUD-TAR		\$350	Latest Rev. of M68302SWLB-TAR — must have original S/W
M302SWLDUD-DOS		\$350	Latest Rev. of M68302SWLD-DOS — must have original S/W
M302SWLDUD-TAR		\$350	Latest Rev. of M68302SWLD-TAR — must have original S/W
M68302SWPRO-DOS		\$2,000	M68302 Profibus Microcode on MS-DOS 5.25" Diskette
M68302SWSS7-DOS		\$2,000	M68302 Signalling System #7 Microcode on MS-DOS 5.25" Diskette
M68302SWSS7-TAR		\$2,000	M68302 Signalling System #7 Microcode on DC600A Cartridge Tape
M302SWX25UD-DOS		\$350	Latest Rev. of M68302SWX25-DOS — must have original S/W
M302SWX25UD-TAR		\$350	Latest Rev. of M68302SWX25-TAR — must have original S/W
M68356ADS		\$1,995	MC68356 Application Development System
M68356ADI-PC		\$350	M68356 ADS Interface Card for IBM PC
M68360ADI-PC		\$350	M68360QUADS I/F for IBM PC
M68360ADI-SUN4		\$350	M68360QUADS I/F for SUN4
M68360QUADS		\$1,995	MC68360 QUICC Application Development System (for 68360 & 68EN360)
M68360QUADS-040		\$2,995	MC68360 Development Board Utilizing "360/040 Companion Mode"
M68360SWAHDL-DOS		\$2,000	M68360 ASYNC HDLC Microcode
M68360SWSP-DOS			Free on Web
M68360SWSP-TAR			Free on Web
M68360SWEDX-TAR			Free on Web
M68360SWSS7-DOS		\$2,000	M68360 Signalling System #7 Microcode on 5.25" Diskette (One Time Fee)
M68360SWMGCI-DOS		\$2,000	Multiple GCI Microcode
M68360SWATM1-DOS		\$2,000	ATM, (ATM over T1/E1) Microcode
M68360SWPRO-DOS		\$2,000	Profibus Controller Microcode
MPC850FADS		\$2,645	MPC850 FADS (Includes 8xx Mother Board and 850 Daughter Board)
MPC860ADS		\$2,645	MPC860 Application Development System
MPC860ADS-PC		\$2,995	MPC860 ADS kit w/ ADI for IBM PC
MPC860ADS-SUN4		\$2,995	MPC860 ADS kit w/ ADI for SUN4
MPC860ADI-PC		\$350	MPC860 ADI for IBM PC
MPC860ADI-SUN4		\$350	MPC860 ADI for SUN4
MPC860FADS		\$2,645	MPC860 Family Application Development System
MPC860SRFADS		\$2,645	MPC860FADS (for MPC860SR)
MPC860TFADS		\$2,645	MPC860FADS (for MPC860T)
MPC860SR-PHY		\$1,195	MPC860SAR ADS PHY Board
MPC860SWSS7-DOS		\$2,000	MPC860 Signalling System #7 Microcode on 5.25" Diskette (One Time Fee)
MPC860SWATM1-DOS		\$2,000	ATM, (ATM over T1/E1) Microcode

NOTES RESALE = SUGGESTED RESALE, COST = DISTRIBUTOR COST AT 80% OF RESALE

- They are non-cancelable
- The Following Symbols Indicate Software License Agreement Codes:
 - # Object Code Ships with Motorola "Shrink Wrap" Software License Agreement
 - % Source Code Requires Motorola Software License Agreement
- For Third Party Software Refer to the HPESD Source for 68K and Coldfire. Order BR729/D from LDC.

4



IMAGING AND STORAGE DIVISION DEVELOPMENT SYSTEMS PART LIST

DEVICE	SUGGESTED RESALE	DESCRIPTION
M68EC000IDP	\$510	Integrated Development Platform used for 68EC000 evaluation/development
M68EC020IDP	\$595	Integrated Development Platform used for 68EC020 evaluation/development
M68EC030IDP3	\$650	Integrated Development Platform used for 68EC030 evaluation/development
M68EC040IDP3	\$750	Integrated Development Platform used for 68EC040 evaluation/development
M68EC060IDP	\$850	Integrated Development Platform used for 68EC060 evaluation/development
M68306AN	\$349	MC68306 Evaluation System
M68307EVM	\$349	MC68307 Evaluation System
M68340EST	\$500	MC68340 Evaluation System
M5102EVM	\$275	5102 Evaluation Module (Requires M68EC040IDP3 board)
M5202EVM	\$495	5202 Evaluation Module (Requires M68EC040IDP3 board)
M5202GW	\$99	Coldfire Gateway board for systems using MC68EC000FN sockets
M5204AN	\$250	Amewsh Evaluation System for MCF5204
M5206AN	\$250	Amewsh Evaluation System for MCF5206
PortASM/68K	NC	MicroAPL 68K/CPU32/CPU32+ assembly code to ColdFire assembly code converter Available only @ URL www.mot.com/ColdFire

NOTES • For Third Party Software refer to the HPESD Source Catalog. Order BR729/D from LDC.



SOFTWARE LICENSE

MOTOROLA MPU/MCU DEVELOPMENT SYSTEMS PRODUCTS

Motorola software is available in two forms: **Source** and **Object Code**. All software requires a license from Motorola for the customer to own a copy and to use the software.

Object Code software is shipped with the "Shrink Wrap" Software License Agreement. This license is provided with the software product and does not require the customer to sign any agreement. If the customer opens the software package, then he agrees to the conditions of the software license agreement.

Some Motorola **Object Code** software includes software from third party vendors and their licenses are included with the Motorola "Shrink Wrap" license. If the customer opens the software package, then he agrees to the conditions of all included software license agreements.

4

Source Code software requires the customer to sign the Motorola Software License Agreement (a copy follows) before the software product is delivered to the customer. The customer may not redistribute any Motorola **Source Code**. If the customer wishes to redistribute software that includes Motorola **Source Code** embedded as object code in the customer's product, then a royalty payment schedule must be first agreed to. The respective Motorola marketing group will negotiate redistribution requirements.

Some Motorola **Source Code** software includes AT&T Technologies software and an additional license is required by AT&T Technologies which must be arranged separately by the customer and AT&T Technologies.



MOTOROLA INC.

Semiconductor Products Sector

FO# _____

Distributor/Customer Code _____

SOFTWARE LICENSE AGREEMENT

THIS AGREEMENT, entered into by and between MOTOROLA INC., SEMICONDUCTOR PRODUCTS SECTOR, a corporation of Delaware, with offices at 5005 East McDowell Road, Phoenix, Arizona 85008 (hereinafter called "MOTOROLA") and _____

_____ (hereinafter referred to as "LICENSEE") and effective as of the date of last signature hereto.

WITNESSETH

WHEREAS, MOTOROLA has rights in certain software identified in Paragraph 2 of this Agreement, and

WHEREAS, LICENSEE desires to acquire the right to use an unmodified or derivative version of the software identified in Paragraph 2 (hereinafter the "Licensed Program(s)"), and

WHEREAS, MOTOROLA is willing to grant such rights as hereinafter defined in consideration of payment as hereinafter set forth.

NOW, THEREFORE, in consideration of the mutual covenants and conditions set forth herein it is agreed as follows:

1. LICENSE. MOTOROLA grants to LICENSEE a non-exclusive license under MOTOROLA'S copyright and under MOTOROLA'S information contained in and associated with the Licensed Program(s) to modify the software in order to produce a derivative version thereof and to use the Licensed Program(s) only for its own internal use in a single system at each of the following locations:

2. PAYMENT. The rights granted hereunder are contingent upon the following payments to MOTOROLA for each of the identified software packages within thirty (30) days after receipt of invoice and delivery to LICENSEE.

1. _____ (\$ _____)
2. _____ (\$ _____)
3. _____ (\$ _____)
4. _____ (\$ _____)

3. RIGHT TO COPY OR MERGE.

- a. The Licensed Program(s) may be copied, in whole or in part, for LICENSEE'S internal use only, provided, however, that no more than five (5) copies will be in existence under this Agreement at any one time without prior written consent of MOTOROLA. Additional copies of the Licensed Program(s) may be licensed from MOTOROLA at the then current licensing fee.
- b. With reference to copies it makes of the Licensed Program(s), LICENSEE agrees to reproduce any MOTOROLA copyright notice, and other proprietary legend, appearing thereon and to include the same on all copies it makes in whole or in part. Such copyright notice(s) may appear in any several forms, including machine-readable form, and LICENSEE agrees to reproduce such notice in each form in which it appears, to the extent it is physically possible to do so.

4. PROGRAM REMAINS MOTOROLA'S PROPERTY.

- a. Title to the Licensed Program(s) and all rights therein, including all rights in patents, copyrights, and trade secrets applicable thereto, shall remain vested in MOTOROLA. Any copies made by LICENSEE, in whole or in part, shall remain vested in MOTOROLA or its licensor.
- b. LICENSEE agrees not to provide or otherwise make available in any form the Licensed Program(s), or any portion thereof, to any person other than employees of LICENSEE or MOTOROLA without prior written consent of MOTOROLA, except that if a Licensed Program in object code form is embodied in LICENSEE'S equipment, the transfer of such equipment shall convey to LICENSEE'S transferee a license to use the Licensed Program(s) in such equipment under terms commensurate with the terms set forth in this Agreement and LICENSEE'S rights under this Agreement shall terminate upon such transfer.



5. **TERMINATION.** This Agreement may be terminated by LICENSEE upon one month's prior written notice. MOTOROLA may terminate this Agreement if LICENSEE is in default of any of the terms and conditions of this Agreement, and termination is effective if LICENSEE fails to correct such default within thirty (30) days after written notice thereof by MOTOROLA.
6. **TERMINATION CERTIFICATE.** Within one month after termination of this Agreement, LICENSEE will furnish to MOTOROLA a certificate certifying with respect to each Licensed Program delivered to LICENSEE hereunder that through its best effort, and to the best of its knowledge, the original and all copies, in whole or in part, in any form, of the Licensed Program(s) have been destroyed, except that, with prior written consent from MOTOROLA, LICENSEE may retain one copy for archival purposes.
7. **MAINTENANCE.** MOTOROLA shall not be responsible for maintenance or field service of the Licensed Program(s) or derivative versions under this Agreement.
8. **DISCLAIMER OF WARRANTY.**
 - a. The Licensed Program(s) is (are) provided on an "AS IS" basis and without warranty. IN NO EVENT SHALL MOTOROLA BE LIABLE FOR INCIDENTAL OR CONSEQUENTIAL DAMAGES ARISING FROM USE OF THE LICENSED PROGRAM(S). THIS DISCLAIMER OF WARRANTY EXTENDS TO LICENSEE, TO LICENSEE'S TRANSFEREES AND TO LICENSEE'S CUSTOMERS OR USERS OF PRODUCTS AND IS IN LIEU OF ALL WARRANTIES WHETHER EXPRESS, IMPLIED, OR STATUTORY, INCLUDING IMPLIED WARRANTIES OF MERCHANTABILITY OR FITNESS FOR PARTICULAR PURPOSE.
 - b. MOTOROLA does not represent or warrant that the Licensed Program(s) furnished hereunder are free of infringement of any third party patents, copyrights or trade secrets.
9. **EXPORT.** LICENSEE agrees that it will not in any form export, reexport, resell, ship or divert or cause to be exported, reexported, resold, shipped or diverted, directly or indirectly, Licensed Program(s) or a direct product thereof to any country for which the United States Government or any agency thereof at the time of export or reexport requires an export license or other governmental approval without first obtaining such license or approval.
10. The terms of this Agreement shall prevail over any U.S. Government procurement policy, regulation, or contract clause relating to rights in computer software.
11. All notices in connection with this Agreement shall be in writing and may be given by any convenient means at the following address:

4

If to MOTOROLA:

MOTOROLA INC., SEMICONDUCTOR PRODUCTS SECTOR

505 Barton Springs Road, Suite 100
Austin, TX 78704

Attn: Don Smith

If to LICENSEE: (to address above unless stated herein)

For purposes of this Agreement, a notice shall be deemed effective upon receipt by the noticed party.

12. This Agreement shall be governed and interpreted by the laws of the State of Arizona.
13. This license may not be assigned or otherwise transferred by LICENSEE without prior written consent of MOTOROLA.
14. This Agreement sets forth the entire understanding between the parties with respect to the subject matter herein, and merges and supercedes all prior written agreements, discussions and understandings, expressed or implied, concerning such matters, and shall take precedence over any conflicting terms which may be contained in LICENSEE'S purchase order or MOTOROLA'S order acknowledgement forms.

IN WITNESS WHEREOF, the parties have caused this Agreement to be executed as of the day and year of the last signature hereto.

	Date _____	Title _____
By _____ (AUTHORIZED SIGNATURE)	MOTOROLA INC.	
Title _____	By _____ (AUTHORIZED SIGNATURE)	Date _____



MCTG DEVELOPMENT TOOLS PRICE MATRIX

MMDS11 SYSTEM SOLUTIONS

Device	Package	MMDS Station Module	Emulator Module (EM)	Flex Cable	Target Head	Resale
M68HC11A8	48-pin plastic DIP (P)	M68MMDS11	M68EM11E20	M68CBL11B	M68TB11E20P48	\$5,520.00
	52-lead PLCC (FN)	M68MMDS11	M68EM11E20	M68CBL11C	M68TC11E20FN52	\$5,610.00
	64-lead QFP (FU)	M68MMDS11	M68EM11E20	M68CBL11C	M68TC11E20FU64	\$5,620.00
M68HC11D3	40-pin plastic DIP (P)	M68MMDS11	M68EM11D3	M68CBL11C	M68TC11D3P40	\$5,420.00
	44-lead PLCC (FN)	M68MMDS11	M68EM11D3	M68CBL11C	M68TC11D3FN44	\$5,495.00
	44-lead QFP (FB)	M68MMDS11	M68EM11D3	M68CBL11C	M68TC11D3FB44	\$5,620.00
M68HC711D3	40-pin plastic DIP (P)	M68MMDS11	M68EM11D3	M68CBL11C	M68TC11D3P40	\$5,420.00
	44-lead PLCC (FN)	M68MMDS11	M68EM11D3	M68CBL11C	M68TC11D3FN44	\$5,495.00
M68HC11E9, -711E9	52-lead PLCC (FN)	M68MMDS11	M68EM11E20	M68CBL11C	M68TC11E20FN52	\$5,610.00
	52-lead QFP (PB)	M68MMDS11	M68EM11E20	M68CBL11C	M68TC11E20PB52	\$5,620.00
	64-lead QFP (FU)	M68MMDS11	M68EM11E20	M68CBL11C	M68TC11E20FU64	\$5,620.00
M68HC11E20, -711E20	52-lead PLCC (FN)	M68MMDS11	M68EM11E20	M68CBL11C	M68TC11E20FN52	\$5,610.00
	64-lead PLCC (FU)	M68MMDS11	M68EM11E20	M68CBL11C	M68TC11E20FU64	\$5,620.00
M68HC11E2	48-pin plastic DIP (P)	M68MMDS11	M68EM11E20	M68CBL11B	M68TB11E20P48	\$5,520.00
	52-lead PLCC (FN)	M68MMDS11	M68EM11E20	M68CBL11C	M68TC11E20FN52	\$5,610.00
M68HC11F1	68-lead PLCC (FN)	M68MMDS11	M68EM11F1	M68CBL11C	M68TC11F1FN68	\$5,520.00
	80-lead TQFP (PU)	M68MMDS11	M68EM11F1	M68CBL11C	M68TC11F1PU80	\$5,670.00
M68HC11G5, -G7	84-lead PLCC (FN)	M68MMDS11	M68EM11G5	M68CBL11D	M68TD11G5FN84	\$5,550.00
M68HC11K4, -711K4	80-lead TQFP (FU)	M68MMDS11	M68EM11K4	M68CBL11E	M68TE11K4FU80	\$5,700.00
	84-lead PLCC (FN)	M68MMDS11	M68EM11K4	M68CBL11D	M68TD11K4FN84	\$5,550.00
M68HC11KA2, -711KA2	68-lead PLCC (FN)	M68MMDS11	M68EM11KA4	M68CBL11C	M68TC11KA4FN68	\$5,520.00
M68HC11KA4, -711KA4	68-lead PLCC (FN)	M68MMDS11	M68EM11KA4	M68CBL11C	M68TC11KA4FN68	\$5,520.00
M68HC11L6, -711L6	64-lead QFP (FN)	M68MMDS11	M68EM11L6	M68CBL11C	M68TC11L6FU64	\$5,620.00
	68-lead PLCC (FN)	M68MMDS11	M68EM11L6	M68CBL11C	M68TC11L6FN68	\$5,520.00
M68HC11P2, -711P2	84-lead PLCC (FN)	M68MMDS11	M68EM11P2	M68CBL11D	M68TD11K4FN84	\$5,520.00
M68HC11PH8	84-lead PLCC (FN)	M68MMDS11	M68EM11PH8	M68CBL11D	M68TD11PH8FN84	\$5,575.00
		M68MMDS11	M68EM11PH8	M68CBL11D	M68TD11PH8PU100	\$5,750.00



MCTG DEVELOPMENT TOOLS PRICE MATRIX

M68HC11 EVALUATION SYSTEM SOLUTIONS

Device	Package	Platform Board (PFB)	Emulator Module (EM)	Flex Cable	Target Head	Resale
M68HC11A8	48-pin plastic DIP (P)	M68HC11PFB	M68EM11E20	M68CBL11B	M68TB11E20P48	\$870.00
	52-lead PLCC (FN)	M68HC11PFB	M68EM11E20	M68CBL11C	M68TC11E20FN52	\$960.00
	52-lead QFP (PB)	M68HC11PFB	M68EM11E20	M68CBL11C	M68TC11E20PB52	\$970.00
	64-lead QFP (FU)	M68HC11PFB	M68EM11E20	M68CBL11C	M68TC11E20FU64	\$970.00
M68HC11D3	40-pin plastic DIP (P)	M68HC11PFB	M68EM11D3	M68CBL11C	M68TC11D3P40	\$770.00
	44-lead PLCC (FN)	M68HC11PFB	M68EM11D3	M68CBL11C	M68TC11D3FN44	\$845.00
	44-lead QFP (FB)	M68HC11PFB	M68EM11D3	M68CBL11C	M68TC11D3FB44	\$970.00
M68HC711D3	40-pin plastic DIP (P)	M68HC11PFB	M68EM11D3	M68CBL11C	M68TC11D3P40	\$770.00
	44-lead PLCC (FN)	M68HC11PFB	M68EM11D3	M68CBL11C	M68TC11D3FN44	\$845.00
M68HC11E9, -711E9	52-lead PLCC (FN)	M68HC11PFB	M68EM11E20	M68CBL11C	M68TC11E20FN52	\$960.00
	52-lead QFP (PB)	M68HC11PFB	M68EM11E20	M68CBL11C	M68TC11E20PB52	\$970.00
	64-lead QFP (FU)	M68HC11PFB	M68EM11E20	M68CBL11C	M68TC11E20FU64	\$970.00
M68HC11E20, -711E20	52-lead PLCC (FN)	M68HC11PFB	M68EM11E20	M68CBL11C	M68TC11E20FN52	\$960.00
	64-lead PLCC (FU)	M68HC11PFB	M68EM11E20	M68CBL11C	M68TC11E20FU64	\$970.00
M68HC11E2	48-pin plastic DIP (P)	M68HC11PFB	M68EM11E20	M68CBL11B	M68TB11E20P48	\$870.00
	52-lead PLCC (FN)	M68HC11PFB	M68EM11E20	M68CBL11C	M68TC11E20FN52	\$960.00
M68HC11F1	68-lead PLCC (FN)	M68HC11PFB	M68EM11F1	M68CBL11C	M68TC11F1FN68	\$870.00
	80-lead TQFP (PU)	M68HC11PFB	M68EM11F1	M68CBL11C	M68TC11F1PU80	\$1,020.00
M68HC11G5, -G7	84-lead PLCC (FN)	M68HC11PFB	M68EM11G5	M68CBL11D	M68TD11G5FN84	\$900.00
M68HC11K4, -711K4	80-lead TQFP (FU)	M68HC11PFB	M68EM11K4	M68CBL11E	M68TE11K4FU80	\$1,050.00
	84-lead PLCC (FN)	M68HC11PFB	M68EM11K4	M68CBL11D	M68TD11K4FN84	\$900.00
M68HC11KA2, -711KA2	68-lead PLCC (FN)	M68HC11PFB	M68EM11KA4	M68CBL11C	M68TC11KA4FN68	\$870.00
M68HC11KA4, -711KA4	68-lead PLCC (FN)	M68HC11PFB	M68EM11KA4	M68CBL11C	M68TC11KA4FN68	\$870.00
	64-lead QFP (FU)	M68HC11PFB	M68EM11KA4	M68CBL11C	M68TC11KA4FU64	\$870.00
M68HC11L6, -711L6	64-lead QFP (FN)	M68HC11PFB	M68EM11L6	M68CBL11C	M68TC11L6FU64	\$970.00
	68-lead PLCC (FN)	M68HC11PFB	M68EM11L6	M68CBL11C	M68TC11L6FN68	\$870.00
M68HC11P2, -711P2	84-lead PLCC (FN)	M68HC11PFB	M68EM11P2	M68CBL11D	M68TD11K4FN84	\$900.00
M68HC11PH8	84-lead PLCC (FN)	M68HC11PFB	M68EM11PH8	M68CBL11D	M68TD11PH8FN84	\$970.00
	100-lead TQFP (PU)	M68HC11PFB	M68EM11PH8	M68CBL11D	M68TD11PH8PU100	\$1,350.00

4



MCTG DEVELOPMENT TOOLS PRICE MATRIX

SERIAL PROGRAMMER SOLUTIONS

Device	Package	Programing Adapter	Serial Programmer	Resale
M68HC11A8	48-pin plastic DIP (P)	M68PA11A8P48	M68SPGMR11	\$400.00
	52-lead PLCC (FN)	M68PA11E20FN52	M68SPGMR11	\$400.00
	64-lead QFP (FU)	M68PA11E20FU64	M68SPGMR11	\$425.00
M68HC11D3	40-pin plastic DIP (P)	M68PA11D3P40	M68SPGMR11	\$400.00
	44-lead PLCC (FN)	M68PA11D3FN44	M68SPGMR11	\$400.00
	44-lead QFP (FB)	M68PA11D3FB44	M68SPGMR11	\$400.00
M68HC711D3	40-pin plastic DIP (P)	M68PA11D3P40	M68SPGMR11	\$400.00
	44-lead QFP (FB)	M68PA11D3FB44	M68SPGMR11	\$400.00
M68HC11E9, -711E9	52-lead PLCC (FN)	M68PA11E20FN52	M68SPGMR11	\$400.00
	52-lead QFP (PB)	M68PA11E20PB52	M68SPGMR11	\$425.00
	64-lead QFP (FU)	M68PA11E20FU64	M68SPGMR11	\$425.00
M68HC11E20, -711E20	52-lead PLCC (FN)	M68PA11E20FN52	M68SPGMR11	\$400.00
	64-lead PLCC (FU)	M68PA11E20FU64	M68SPGMR11	\$425.00
M68HC11E2	48-pin plastic DIP (P)	M68PA11A8P48	M68SPGMR11	\$400.00
	52-lead PLCC (FN)	M68PA11E20FN52	M68SPGMR11	\$400.00
M68HC11F1	68-lead PLCC (FN)	M68PA11F1FN68	M68SPGMR11	\$400.00
	80-lead TQFP (PU)	M68PA11F1PU80	M68SPGMR11	\$425.00
M68HC11G5, -G7	84-lead PLCC (FN)	M68PA11G5FN84	M68SPGMR11	\$400.00
M68HC11K4, -711K4	80-lead TQFP (FU)	M68PA11K4FU80	M68SPGMR11	\$400.00
	84-lead PLCC (FN)	M68PA11K4FN84	M68SPGMR11	\$400.00
M68HC11KA2, -711KA2	68-lead PLCC (FN)	M68PA11KA4FN68	M68SPGMR11	\$400.00
M68HC11KA4, -711KA4	68-lead PLCC (FN)	M68PA11KA4FN68	M68SPGMR11	\$400.00
M68HC11L6, -711L6	64-lead QFP (FN)	M68PA11L6FU64	M68SPGMR11	\$425.00
	68-lead PLCC (FN)	M68PA11L6FN68	M68SPGMR11	\$400.00
M68HC11P2, -711P2	84-lead PLCC (FN)	M68PA11K4FN84	M68SPGMR11	\$400.00
M68HC11PH8	84-lead PLCC (FN)	M68PA11PH8FN84	M68SPGMR11	\$450.00
	100-lead TQFP (PU)	M68PA11PH8PU100	M68SPGMR11	\$575.00



MCTG DEVELOPMENT TOOLS PRICE MATRIX

MEVB 1632 MODULAR EVALUATION BOARD

Emulated MCU (Package)	MPB	MPFB	ICD	Resale
M68HC16V1C (100 TQFP (PU))	M68MPB16V1C	M68MPFB1632	M68ICD16	\$1,494.50
M68HC16S2B (100 TQFP (PU))	M68MPB16S2B	M68MPFB1632	M68ICD16	\$1,494.50
M68HC916X1 (120 PQFP (FH))	M68MPB916X1C	M68MPFB1632	M68ICD16	\$1,399.50
M68HC16Y1 (160 PQFP (FT))	M68MPB16Y1B	M68MPFB1632	M68ICD16	\$1,399.50
M68HC16Z1 (132 PQFP (FC))	M68MPB16Z1B	M68MPFB1632	M68ICD16	\$1,399.50
M68331 (132 PQFP (FC))	M68MPB331B	M68MPFB1632	M68ICD32	\$1,494.50
M68332A (132 PQFP (FC))	M68MPB332AB	M68MPFB1632	M68ICD32	\$1,494.50
M68332G (132 PQFP (FC))	M68MPB332GB	M68MPFB1632	M68ICD32	\$1,494.50
M68F333 (160 PQFP (FT))	M68MPBF333C	M68MPFB1632	M68ICD32	\$1,994.50
M68334 (132 PQFP (FC))	M68MPB334B	M68MPFB1632	M68ICD32	\$1,494.50
M68336 (160 PQFP (FT))	M68MPB336GB	M68MPFB1632	M68ICD32	\$1,494.50
M68376 (160 QFP (FT))	M68MPB376GB	M68MPFB1632	M68ICD32	\$1,494.50

4



MCTG DEVELOPMENT TOOLS PRICE MATRIX

MMDS1632 SYSTEM SOLUTIONS

Device	Package	MMDS Station Module	MPB	PPB (Connection Method)	Resale
M68HC16S2	100 QFP (PU)	M68MMDS1632	M68MPB16S2B	M68PPB16PUBG (Rigid-Flex)	\$14,095.00
M68HC16Y1	160 QFP (FT)	M68MMDS1632	M68MPB16Y1B	X68PPB16FTAD (TQ PACK) M68PPB16FTAG (Rigid-Flex)	\$13,540.00 \$14,000.00
M68HC16Z1	132 PQFP (FC)	M68MMDS1632	M68MPB16Z1B	X68PPB16FCAD (TQ PACK) M68PPB16FCAG (Rigid-Flex)	\$13,540.00 \$14,000.00
M68331	132 PQFP (FC)	M68MMDS1632	M68MPB331B	M68PPB32FCAD (TQ PACK) M68PPB32FCAG (Rigid-Flex)	\$13,635.00 \$14,095.00
M68332A	132 PQFP (FC)	M68MMDS1632	M68MPB332AB	M68PPB32FCAD (TQ PACK) M68PPB32FCAG (Rigid-Flex)	\$13,635.00 \$14,096.00
M68332G	132 PQFP (FC)	M68MMDS1632	M68MPB332GB	M68PPB32FCAD (TQ PACK) M68PPB32FCAG (Rigid-Flex)	\$13,635.00 \$14,095.00
M68F333C	160 QFP (FT)	M68MMDS1632	M68MPBF333C	X68PPB32FTAD (TQ PACK) M68PPB32FTBG (Rigid-Flex)	\$14,135.00 \$14,595.00
M68376	160 QFP (FT)	M68MMDS1632	M68MPB376GB	M68PPB32FTCG (Rigid-Flex)	\$14,095.00



MCTG DEVELOPMENT TOOLS PRICE MATRIX

M68HC11 EVB/EVBU

	Component	Component Part Number	Resale
	M68HC11 Evaluation Board	M68HC11EVB	\$199.00
	M68HC11 Universal Eval Board	M68HC11EVBU	\$175.00

M68HC12 EVB

	Part Number	Resale	
	M68HC812A4 Evaluation Board	M68HC12A4EVB	\$412.00
	M68HC912B32 Evaluation Bd	M68EVB912B32	\$99.00

MPC505 EVB

	Component	Component Part Number	Resale
	MPC505 Evaluation Board	MPC505EVB	\$975.00

M68331 and M68332A/G EVALUATION KITS

Device	Platform Board	Business Card Computer	Resale
M68331	M68300PFB	M68BCC331	\$700.00
M68332A	M68300PFB	M68BCC332A	\$700.00
M68332G	M68300PFB	M68BCC332G	\$700.00

4

SERIAL IN-CIRCUIT DEBUGGER (1)

MCU	Software Part Number	Hardware Part Number	Voltage	Resale
M68HC16	M68SDEBUG16AB	M68SDI	5 V	\$300.00
M68HC16	M68SDEBUG16AB	M68SDIL	2.7 – 5.5 V	\$300.00
M68300	M68SDEBUG32AB	M68SDI	5 V	\$300.00
M68300	M68SDEBUG32AB	M68SDIL	2.7 – 5.5 V	\$300.00

	Software	Resale
	M68SDEBUG12AB	\$150.00
	M68SDEBUG16AB	\$150.00
	M68SDEBUG32AB	\$150.00

(1) SDI and Software must be ordered separately



MCTG DEVELOPMENT TOOLS PRICE MATRIX

EMBEDDED MCU SOFTWARE TOOLS

Software Package	MCU	Part Number	Resale
MCUinit		M68FMSINITBDX30	\$195.00
MCUasm	M68HC05	MHC05SASMxBBX12	\$400.00
	M68HC08	MHC08SASMxBBX12	\$400.00
	M68HC11	MHC11SASMxBBX12	\$400.00
	M68HC12	MHC12SASMxBBX12	\$400.00
	M68HC16	MHC16SASMxBBX12	\$400.00
TPUMASM		M68FMSTPASBBXXX	\$495.00

PowerPC DEVELOPMENT TOOLS

Component	Host System	Part Number	Resale
C-Compiler Package	SUN OS 4.1.3	MPPC5SCCOMDBX11	\$4,500.00
	AIX 3.2.5	MPPC5SCCOMEBX11	\$4,500.00
	HP UX	MPPC5SCCOMFBX11	\$4,500.00
	Windows95 & NT	MPPC5SCCOMHDX20	\$2,500.00
Debugger Package	SUN OS 4.1.3	MPPC5SDEBGBDX11	\$3,600.00
	AIX 3.2.5	MPPC5SDEBGBX11	\$3,600.00
	HP UX	MPPC5SDEBGBX11	\$3,600.00
	Windows95 & NT	MPPC5SDEBGHDX20	\$2,000.00
Complete PowerPC Tool Suite	SUN OS 4.1.3	MPCC5SCMDBDBX11	\$7,500.00
	AIX 3.2.5	MPCC5SCMDBEBX11	\$7,500.00
	HP UX	MPCC5SCMDBFBX11	\$7,500.00
	Windows95 & NT	MPCC5SCMDBHDX20	\$4,000.00

DEBUGGER SOFTWARE FOR THE SDI

Software Package	MCU	Part Number	Resale
S-Dbug	M68HC12	M68SDEBUG12AB	\$150.00
	M68HC16	M68SDEBUG16AB	\$150.00
	M68300	M68SDEBUG32AB	\$150.00

RTEK KERNEL

Software Developer's Kit (SDK) for Sun4 workstations (SunOS)

Device	Part Number	Resale
MPC500	MPPC5SRTEKDBX11	\$4,800

SDK for PC (Windows 3.1)

Device	Part Number	Resale
M68HC12	MHC12SRTEKBBX12	\$3,000
M68HC16	MHC16SRTEKBBX12	\$3,250
M68300	M683FSRTEKBBX12	\$3,500
MPC800	MPPC8SRTEKBBX12	\$4,000



HC05 – DIRECT REPLACEMENTS

Component	Part Number	Resale
EVS	M68HC05C5EVS	\$498.00
	M68HC05C9EVS	Replaced by M68EM05C9 & M68MMPFB0508
	M68HC05D32EVS	Replaced by M68HC05D32EM & M68MMPFB0508
	M68HC05E1EVS	Replaced by X68EM05E5 & M68MMPFB0508
	M68HC05G1EVS	Replaced by M68EM05G1 & M68MMPFB0508
	M68HC05J3EVS	Replaced by M68EM05J3 & M68MMPFB0508
	M68HC05L1EVS	Replaced by M68EM05L1 & M68MMPFB0508
	M68HC05L2EVS	Replaced by M68EM05L2 & M68MMPFB0508
	M68HC05L5EVS	Replaced by M68EML0516 & M68MMPFB0508
	M68HC05P3EVS	Replaced by M68HC05P3 & M68MMPFB0508
	M68HC05P8EVS	Replaced by M68HC05JPEM & M68MMPFB0508
	M68HC05P9EVS	Replaced by M68HC05P9EM & M68MMPFB0508
	M68HC05T2EVS	\$498.00
	M68HC05X4EVS	Replaced by M68EM05X4 & M68MMPFB0508

4



Blue Chip Program

Blue Chip Technical Distribution Program 5-2 (Rev. Apr. 97)

5



BLUE CHIP TECHNICAL DISTRIBUTION PROGRAM

Devices included in the Motorola Blue Chip Technical Distribution Program are identified by a program code “**B**”.

In addition, some devices which do not appear in this price book (non-price book devices) are also included in the Motorola Blue Chip Technical Distribution Program. Please contact your nearest Motorola sales office for a complete listing of devices on the Blue Chip Technical Distribution Program.

PILOT PRODUCTION PROTOTYPES

To facilitate the design-in and sales of Motorola high technology devices, they are routinely placed on the Blue Chip Technical Distribution Program and made available for sale as pilot production prototypes. These devices can be identified by device part number marking beginning with “**XC**” or “**XPC**”. “**XC**” or “**XPC**” devices may be either “book devices” (appearing in this book) or non-book.

“**XC**” or “**XPC**” devices are manufactured, tested and QA inspected to planned normal production requirements. “**XC**” or “**XPC**” devices are released only after completion of preliminary reliability and characterization testing but prior to completion of Motorola’s rigorous internal reliability qualifications. Specifications for “**XC**” or “**XPC**” devices may change at any time.





MOTOROLA

Semiconductor Products Sector

NORTH AMERICA SALES AND DISTRIBUTION COMMERCIAL DEVICES & DEVELOPMENT SYSTEMS

EFFECTIVE DATE: JANUARY 10, 1998

THIS BOOK IS IN COMPUTER SORT:

- COMMERCIAL DEVICES & DEVELOPMENT SYSTEMS

PC = PRODUCT CLASSIFICATION - Please see General
Information Section 1-3

Commercial Components and Development Systems Pricing

Quick Reference QR-1 (Rev. Jan. 98)
Commercial Components
and Development Systems Pricing 1 (Rev. Jan. 98)

6



QUICK REFERENCE COMPONENTS

NEW LISTINGS

DEVICE

BZX79C10RL
BZX79C100RL
KITEVS11E20FN52
KITITC132/D
KITITC137/D
KITMMEVS05P9P28
LM211DR2
LM224DR2
LM239ADR2
LM239DR2
LM258DR2
LM285Z-1.2RA
LM285Z-2.5RA
LM2901DR2
LM2902DR2
LM2902VDR2
LM2903DR2
LM2903VDR2
LM2904DR2
LM2904VDR2
LM2931AD-5.0R2
LM2931ADT-5.0RK
LM2931AZ-5.0RA
LM2931AZ-5.0RP
LM2931Z-5.0RA
LM301AD
LM301ADR2
LM308ADR2
LM317D2TR4
LM317LBZRA
LM317LBZRP
LM317LZRE
LM317LZRP
LM339ADR2
MAC97A6RLRP
MCF5102PV20B
MCF5102PV25B
MCF5102PV40B
MCH12140DR2
MCLK332ACFC16B1
MCLK332ACPV16B1
MCLK332GCF16B1
MCLK332GCPV16B1
MCM56824AFNC25
MCM56824AFNC35
MCM69C432TQ20
MC100E416FNR2
MC12009D
MC12066D
MC12066DR2
MC12066P
MC12093DR2
MC12095DR2
MC12095SD
MC12181D
MC13077DWR2
MC13110FBR2
MC13135DWR2

New Listings (Cont)

DEVICE

MC13136DWR2
MC13143DR2
MC13144D
MC13144DR2
MC13150FTA
MC13150FTAR2
MC13150FTBR2
MC13158FTBR2
MC14LC5003FU
MC1403BDR2
MC1403BP1
MC1413BDR2
MC1416BDR2
MC143120E2DW
MC1436CDR2
MC1436DR2
MC144112D
MC14447DW
MC145010DWR2
MC145040DWR2
MC145050DWR2
MC145051DT
MC145051DWR2
MC145053DR2
MC145151DW2R2
MC145190EVK
MC145192DTR2
MC145200EVK
MC145201EVK
MC145202DTR2
MC145483DT
MC145483DTR2
MC145483DW
MC145483DWR2
MC145483SD
MC145483SDR2
MC1455BDR2
MC1458CDR2
MC1489DR2
MC1496DR2
MC16S2CPU20B1
MC16Z3KACFC16
MC16Z3KACFC16B1
MC1723BDR2
MC1723CDR2
MC1776CDR2
MC3302D
MC33033DWR2
MC33065DW-HR2
MC33065DW-LR2
MC33066DWR2
MC33067DWR2
MC33110DR2
MC33181DR2
MC33269DR2-012
MC33269DR2-3.3
MC33269DR2-5.0
MC33340DR2

New Listings (Cont)

DEVICE

MC33341DR2
MC33347D
MC33347DTB
MC33362DWR2
MC33363ADWR2
MC33502DR2
MC33560ADTB
MC33560ADW
MC33560DW
MC3361BDR2
MC34012-1DR2
MC34012-2DR2
MC34012-3DR2
MC34119ADTB
MC3423D
MC68CK331CFC16
MC68CK331CFC16B1
MC68CK331CPV16
MC68CK331CPV16B1
MC68EN360ZP25VC
MC68HCP11A0CFN3
MC68HCP11A0FNR2
MC68HCP11A0FU
MC68HCP11A1FNR2
MC68HCP11E1FNR2
MC68HCP11E1VFN2
MC68HC11A0VP
MC68HC11A1CFU3
MC68HC11A1FNR2
MC68HC11A1MFN
MC68HC11A1MP
MC68HC11A1VFN
MC68HC11A1VP
MC68HC11A8P1
MC68HC11C0CFU2
MC68HC11C0CFU3
MC68HC11D0CFB3
MC68HC11D0FNR2
MC68HC11E0CFN2
MC68HC11E0CFN2R2
MC68HC11E0FU
MC68HC11E0MFN2
MC68HC11E0VFN2
MC68HC11E0VFN3
MC68HC11E1CFU3
MC68HC11E1FU
MC68HC11F1CFN3R2
MC68HC11F1FNR2
MC68HC11L0CFU3
MC68HC11L1CFU2
MC68HC11L1CFU3
MC68HC16S2CPU20
MC68HC705MC4CDW
MC68HC705MC4CP
MC68HC711E20CFN3
MC68HC711E20MFN2
MC68HC711E20MFN3
MC68HC711E20VFN2

New Listings (Cont)

DEVICE

MC68HC711E20VFN3
MC68HC711E9MFN2
MC68HC711E9VFN2
MC68HC711L6CFU2
MC68HC711L6CFU3
MC68HC811E2CFN2
MC68HC811E2CP2
MC68HC811E2MFN
MC68HC811E2MFN2
MC68HC811E2VFN
MC68HC811E2VFN2
MC68HC916R1CFC16
MC68LK332ACFC16
MC68LK332GCF16
MC68LK332GCPV16
MC68L11A1FU2
MC68L11D0FB2
MC68L11E0FU2
MC68L11F1FN3
MC68L11K0FN3
MC68L11K1FN3
MC68MH360ZP25VE
MC68S711E9CFN2
MC68020FE33E
MC68322FT16
MC68322FT20
MC68322FT25
MC68340CFT16E
MC68340CFT25E
MC68340CPV16E
MC68340CPV25E
MC68360ZP25VC
MC74ACT05DT
MC74ACT125DTR2
MC74ACT153N
MC74ACT160D
MC74ACT160DR2
MC74ACT160N
MC74ACT162N
MC74ACT534DW
MC74ACT534DWR2
MC74ACT534N
MC74ACT540DT
MC74ACT541DT
MC74ACT541DTR2
MC74ACT564DW
MC74ACT564DWR2
MC74ACT640DW
MC74HCT08ADR2
MC74LCX00DTR2
MC74LCX02DTR2
MC74LCX04DTR2
MC74LCX08DTR2
MC74LCX32DTR2
MC75172BDWR2
MC7808ABT
MC916Y3CFT16

New Listings (Cont)

DEVICE

MC916Y3CFT16B1
MGSF3441VT1
MGS05N60D
MHC11SRTEKHDX20
MHC12SRTEKHDX20
MHC16SRTEKHDX20
MHW1224
MHW2707A1
MHW7185C
MHW7205C
MHW8185
MHW8205
MHW930
MJW21191
MJW21192
MMDJ3P03BJTR2
MMG05N60D
MMJT9435T1
MMJT9435T3
MMSD103T1
MMSD301T1
MMSD4148T1
MMSD701T1
MPAA3BRD
MPAA3DS
MPA1016DD-004
MPA1016DD-006
MPA1016DD-4I
MPA1016DD-6I
MPA1016FN-004
MPA1016FN-006
MPA1016FN-4I
MPA1016FN-6I
MPA1036DD-004
MPA1036DD-006
MPA1036DD-4I
MPA1036DD-6I
MPA1036DH-004
MPA1036DH-006
MPA1036DH-4I
MPA1036DH-6I
MPA1036FN-004
MPA1036FN-006
MPA1036FN-4I
MPA1036FN-6I
MPA1064BG-2I
MPA1064BG-4I
MPA1064BG-6I
MPA1064DH-002
MPA1064DH-004
MPA1064DH-006
MPA1064DH-2I
MPA1064DH-4I
MPA1064DH-6I
MPA1064DK-002
MPA1064DK-004
MPA1064DK-006
MPA1064DK-2I

QUICK REFERENCE COMPONENTS

New Listings (Cont)

DEVICE

MPA1064DK-4I
MPA1064DK-6I
MPA1100BG-002
MPA1100BG-2I
MPA1100BG-4I
MPA1100BG-6I
MPA1100DK-002
MPA1100DK-004
MPA1100DK-006
MPA1100DK-2I
MPA1100DK-4I
MPA1100DK-6I
MPA1765D-I
MPA1765FN-I
MPA1765P-I
MPC850FADS
MPC860FADS
MPC860SR-PHY
MPC860SRFADS
MPC860TFADS
MPPC5SRTEKDBX11
MPPC8SRTEKBBX12
MPXL10GC7U
MPXS4100AC6U
MPXS4115A6U
MPXT4205A7U
MPXT5006D
MPXT5006DF
MPX2200A
MPX2200D
MPX2700A
MPX4100AS
MRF275G
MRF275L
MRF2947AT1
MRF5943R2
MRF8372R2
MRF9811T1
M5202GW
M68BCC331
M68BCC332A
M68BCC332G
M68CBL05D
M68EM11PH8
M68FMSTPASBXXX
M68MPBF333C
M68MPB16S2B
M68MPB16Z1B
M68PA11KA4PU80
M68PA11L6FU64
M68PA11PH8FN84
M68PA11PH8PU100
M68SDIL12
M68TC11D3FB44
M68TC11E20FU64
M68TC11F1PU80
M68TC11KA4FN68
M68TC11KA4FU64
M68TC11L6FN68

New Listings (Cont)

DEVICE

M68TC11L6FU64
M68TQP032SA1
M68TQP044SAMO1
M68TQP044SA1
M68TQP052SB1
M68TQP064SAMO1
M68TQP064SA1
M68TQP072SD1
M68TQP080SBMO1
M68TQP080SB1
M68TQP100RB1
M68TQP100SDMO1
M68TQP100SD1
M68TQP120SDMO1
M68TQP120SD1
M68TQP132SC1
M68TQP144SDMO1
M68TQP144SD1
M68TQP160SBMO1
M68TQP160SB1
M68TQS032SAG1
M68TQS032SAN1
M68TQS044SAF1
M68TQS044SAG1
M68TQS052SBF1
M68TQS052SBG1
M68TQS064SAF1
M68TQS064SAG1
M68TQS072SDF1
M68TQS072SDG1
M68TQS080SBG1
M68TQS080SBN1
M68TQS080SBW1
M68TQS100SDF1
M68TQS100SDG1
M68TQS100SDN1
M68TQS100SDW1
M68TQS120SDF1
M68TQS120SDG1
M68TQS120SDN1
M68TQS120SDW1
M68TQS132SCF1
M68TQS132SCG1
M68TQS132SCN1
M68TQS132SCW1
M68TQS144SDF1
M68TQS144SDG1
M68TQS144SDN1
M68TQS144SDW1
M68TQS160SBF1
M68TQS160SBG1
M68TQS160SBN1
M68TQS160SBW1
M683FSRTEKHDX20
M68300PFB
SPAKXC56L811BU40
SPAKXC56302PV66
SPAKXC56303GC66
SPAKXC56303GC80

New Listings (Cont)

DEVICE

SPMCLK332ACFC16
SPMCLK332ACPV16
SPMCLK332GCFV16
SPMCLK332GCPV16
SPMC16S2CPU20
SPMC16Z3KACFC16
SPMC68CK331CFC16
SPMC68CK331CPV16
SPMC916R1CFC16
SPMC916Y3CFT16
TL072ACDR2
TL431AILPRM
UC2843BD1
UC2843BD1R2
UC2844BDR2
UC2844BN
UC2845BN
UC3843ADR2
XC68HC12A0CPV8
XC68HC705JB2P
XC68HC705KJ1CDW
XC68HC705KJ1CP
XC68HC705KJ1CS
XC68HC708MP16CFU
XC68HC711E9MFS2
XC68HC711K4CFS3
XC68HC711K4CFS4
XC68HC711L6CFS2
XC68HC711L6CFS3
XC68HC711P2CFS3
XC68HC912B32CFU8
1N5230BS
1N5230BSRL
1N5231BS
1N5231BSRL
1N5232BS
1N5232BSRL
1N5234BS
1N5234BSRL
1N5235BS
1N5235BSRL
1N5992BS
1N5992BSRL
1N5994BS
1N5994BSRL
1N5996BS
1N5996BSRL
1N6013BS
1N6013BSRL
1N751AS
1N751ASRL
1N752AS
1N752ASRL
1N753AS
1N753ASRL

DELETIONS

DEVICE

AM26LS30FN
AM26LS31PC
AM26LS32PC
BFR96
DSP56L002PV40
DSP56002RC40
DSP56007EVM
DSP96000ADM
DSP96002FE40
DSP96002FE60
DSP96002RC33
DSP96002RC40
DSP96002RC60
KITDEV1100
LM2931AZ-5.0BP
MCCS142233FN
MCD251FU
MCM518160BJ60
MCM518160BT60
MCM54100AN60
MCM54100AN70
MCM54400AN60
MCM54400AN70
MCM6226BWJ15
MCM6246AWJ15
MCM6246AWJ15R
MCM6246AWJ20
MCM6246AWJ20R
MCM6246AWJ25
MCM6246AWJ25R
MCM6249AWJ15
MCM6249AWJ15R
MCM6249AWJ20
MCM6249AWJ20R
MCM6249AWJ25
MCM6249AWJ25R
MCM94000AS70
MC10111FN
MC10190P
MC10319DW
MC10319DWR2
MC10319P
MC12009FN
MC12031AP
MC12031BD
MC12031BP
MC12036AD
MC12036AP
MC12036BD
MC12036BP
MC13141D
MC13141DR2
MC13281AP
MC13281BP
MC13282AP
MC14C89BP
MC14001UBCL
MC14011UBCL

Deletions (Cont)

DEVICE

MC14013BCPD
MC144110DW
MC144110P
MC144143P2
MC14443P
MC14490PD
MC145073DW
MC145074D
MC145162P1
MC145192EVK
MC145202EVK
MC145220EVK
MC14534BCP
MC14544BCP
MC145447DW
MC145447P
MC14547BCP
MC145537EVK
MC14560BCP
MC14569BCL
MC145705DW
MC145705P
MC145706DW
MC145706P
MC145707P
MC14572UBDR2
MC14583BCP
MC26C31P
MC26C32P
MC2830P
MC33092DWR2
MC33093DWR2
MC33094DWR2
MC33095DR2
MC33120FNR2
MC33166D2TR4
MC33298DW
MC3334P
MC3335DW
MC3335DWR2
MC3357DR2
MC3358DR2
MC34002DR2
MC34014DW
MC34050D
MC34050DR2
MC34050P
MC34051D
MC34051DR2
MC34051P
MC34061P
MC3486D
MC3486P
MC3487D
MC3487DR2
MC3487P
MC44145D
MC44145DR2
MC44200FU

QUICK REFERENCE COMPONENTS

Deletions (Cont)

DEVICE

MC44251FU
MC44802AP
MC54HC175J
MC68B54P
MC68HC000P10
MC68HC000P12
MC68HC000P16
MC68HC000P8
MC68HC11E0FN
MC68HC11E1FN
MC68HC705E1DW
MC68HC705E1P
MC68QH302PV16C
MC68QH302PV20C
MC68QH302PV25C
MC68185FN
MC68340FE16C
MC68340PV16C
MC68340PV16VC
MC68340PV25C
MC6854CP
MC74HCT161ADR2
MC74HCT161AN
MC74HC109D
MC74HC109DR2
MC74HC109N
MC74HC112D
MC74HC112DR2
MC74HC112N
MC74HC160DR2
MC74HC160N
MC74HC194N
MC74HC195N
MC74HC242N
MC74HC354N
MC74HC368N
MC74HC4016DR2
MC74HC4511DR2
MC74HC4511N
MC74HC4853AD
MC74HC51N
MC74HC58DR2
MC74HC58N
MC74LCX16501DT
MC74VHC00N
MC74VHC02D
MC74VHC02DR2
MC74VHC02DT
MC74VHC02DTR2
MC74VHC04D
MC74VHC04DR2
MC74VHC04DT
MC74VHC04DTR2
MC74VHC08D
MC74VHC08DR2
MC74VHC08DT
MC74VHC08DTR2
MC74VHC132N
MC74VHC595N

Deletions (Cont)

DEVICE

MGS1100
MHC16SRTEKBBX12
MHPM6B10A120SL
MHPM6B15A120SL
MHPM6B25A120SL
MHW1224L
MHW607-002
MHW707-001
MHW707-002
MHW707-003
MHW707-004
MHW806A4
MHW808-001
MHW820-001
MHW820-002
MHW851-004
MHW9014
MMBR920LT1
MMBT2907ALT1S
MOC8105
MOC8105S
MOC8105SR2
MOC8105SV
MOC8105T
MOC8105TV
MPA1WV3.1
MPA1WV3.1/DLX
MPA1016DD-I
MPA1016FN
MPA1016FN-I
MPA1036DD
MPA1036DD-I
MPA1036DH
MPA1036DH-I
MPA1036FN
MPA1036FN-I
MPA1036HI
MPA1036HI-I
MPA1064DH
MPA1064DH-I
MPA1064DK
MPA1064DK-I
MPA1064KE
MPA1064KE-I
MPC1710BM
MPM1A120A120C5
MPM1A800A120C5
MPM2A400A120C5
MPM2A600A120C5
MPS3866
MPS3866A
MPX100ASX
MPX200A
MPX200AP
MPX2010GSX
MPX2050GSX
MPX2052D
MPX2052DP
MPX2052GP

Deletions (Cont)

DEVICE

MPX2100AS
MPX2100ASX
MPX2100GVP
MPX2700AP
MPX2700GP
MPX2700GSX
MPX50GVP
MPX5010GSX
MPX5050GSX
MPX5100GSX
MPX5500D
MPX5500DP
MPX5500GP
MPX5500GSX
MPX5700GP2
MPX5700GSX
MPX700AP
MPX700D
MPX700DP
MPX700GP
MPX700GSX
MPX7100AP
MPX7200AP
MPX7200DP
MPX906D
MPX906GVW
MRFIC0001
MRFIC0903
MRFIC0904
MRFIC0912
MRFIC0913
MRFIC0914
MRFIC0914R2
MRFIC0916
MRFIC1501
MRFIC1801
MRFIC1803
MRFIC1804
MRFIC1806
MRFIC1807
MRFIC1808
MRFIC2001
MRFIC2002
MRFIC2003
MRFIC2003R2
MRFIC2004
MRFIC2006
MRFIC2101
MRFIC2401
MRFIC2403
MRFIC2404
MRFQ17R1
MRF1029
MRF1030
MRF1031
MRF1032
MRF158R
MRF4217A
MRF5943

Deletions (Cont)

DEVICE

MRF839F
MRF857
MRF860
MRF861
MRF862
MRF890
MRW2307
MRW53501
MUR430
MUR440
MUR440RL
MUR450
MWA330
M143120EVBU
M143150EVBU
M68MPB332B
M68PA11PH8CQ112
M68SDI
M68TB05T16B56
SAA1042AV
SN75173N
SN75175N
SPAKDSP56002FC40
SPAKDSP56002FC66
SPAKDSP96002FE40
SPAKDSP96002FE60
SPAKDSP96002RC60
SPAKXCB56007FJ50
SPAKXCB56007FJ66
SPAKXC56002PV40
SPAKXC56002PV66
SPAKXC56002PV80
SPAKXC56156FE40
SPAKXC56156FE50
SPAK56L002FC40
TYB14M5574DW
TYB14M5574PB
UAA1016B
ULN2003A
ULN2004A
XCB56007FJ50
XCF5102PV16A
XC56001AFC27
XC56001AFC33
XC56001AFE33
XC56001ARC33
XC56002PV40
XC56002PV66
XC56002PV80
XC56156FE40
XC56156FE50
XC56156FE60
XC56156FV60
XC56166FE60
XC56166FV60
XC56167FV60
XC56303GC100
XC56303PV100
XC68HC705C9ACB

Deletions (Cont)

DEVICE

XC68HC705C9ACFB
XC68HC705C9ACFN
XC68HC705C9ACFS
XC68HC705C9ACP
XC68HC705C9ACS
XC68HC705J1ACS
2N5108
2N5641
2N6056
2N6198
4N32ATV

END OF LIFE

DEVICE

BAV170LT1
BCW60ALT1
BCW61CLT1
BD779
BUL44F
BUS48P
BZX79C100RL
CA2833C
J202
MAD1103P
MAD1107P
MAD1108P
MAD1109P
MAD130P
MCM62X308J15-005
MCM62X308J15-5R2
MCM62X308J17
MCM6226BWJ20
MCM67Q709ZP10
MCM68A10CP
MCM68B10P
MC10111P
MC12002L
MC12009L
MC12013L
MC12022TSAD
MC12022TSAP
MC12022TVAD
MC12022TVAP
MC12025P
MC12040L
MC12061L
MC12073D
MC12073P
MC12074D
MC12075D
MC12076D
MC12083P
MC12090L
MC12101FN
MC12206D
MC12206DT
MC14499P
MC145168P

QUICK REFERENCE COMPONENTS

End of Life (Cont)

DEVICE
 MC33165DW
 MC33165DWR2
 MC33165P
 MC34055DW
 MC34055DWR2
 MC34058FTA
 MC34059FTA
 MC34115DW
 MC34115P
 MC34165DW
 MC34165DWR2
 MC34165P
 MC68B45P
 MC68B488P
 MC68EC030PV25C
 MC68HCB34FN
 MC68HC000R10
 MC68HC000R12
 MC68HC000R8
 MC68349FT16A
 MC68349FT16VA
 MC68349FT25A
 MC6845CP
 MC88100RC20
 MC88100RC25
 MC88100RC33
 MC88200RC20
 MC88200RC25
 MC88200RC33
 MHW1184L
 MHW591
 MHW592
 MHW593
 MHW6205
 MHW6225
 MHW7185A
 MHW7205A
 MHW820-003
 MMAD1103
 MMAD1103R2
 MMAD1107
 MMAD1107R1
 MMAD1108
 MMAD1108R1
 MMAD1108R2
 MMAD1109
 MMAD130
 MMBF4860LT1
 MMBF5459LT1
 MMBTH69LT1
 MMBTH81LT1
 MMPQ2222
 MMPQ2907
 MMPQ3467R2
 MMPQ6842
 MMUN2113LT1
 MPC27T415TQ10
 MPC27T415TQ10R
 MPC27T415TQ9

End of Life (Cont)

DEVICE
 MPC27T416TQ10
 MPC27T416TQ10R
 MPC27T416TQ9
 MPC27T416TQ9R
 MPC955FAR2
 MPC956FAR2
 MPF4391
 MPF4859
 MPF4861A
 MPF971
 MPQ2906
 MPQ7042
 MPSA70
 MPSH81
 MPSL01
 MPSW10
 MPS4124RLRE
 MPS571
 MPS901
 MPS901RLRP
 MRFA2604
 MRF1000MA
 MRF839
 MRF841F
 MRF846
 MRF892
 MRF896
 MRF9011LT1
 MRF9331LT1
 MRW2005
 MRW52604
 MVAM108
 MVAM109
 MVAM115
 MVAM125
 MV1403
 MV1404
 MV1405
 MV1628
 MV1630
 MV1634
 MV1638
 MV1640
 MV1648
 MV2107
 MV7005T1
 MV7005T3
 MV7404T1
 MWA320
 MZ4099
 MZ4099RL
 MZ4101
 MZ4104
 MZ4104RL
 MZ5520B
 MZ5520BRL
 MZ5521B
 MZ5523B
 MZ5523BRL

End of Life (Cont)

DEVICE
 MZ5524B
 MZ5524BRL
 MZ5525B
 MZ5525BRL
 MZ5527B
 PN2907
 SN54LS155J
 TL780-05CKC
 TL780-12CKC
 TL780-15CKC
 1N4372D
 1N4701CRL
 1N5139
 1N5139A
 1N5140
 1N5140A
 1N5144
 1N5144A
 1N5146A
 1N5148
 1N5148A
 1N5230C
 1N5231C
 1N5232D
 1N5235C
 1N5235D
 1N5240C
 1N5244D
 1N5444A
 1N5444B
 1N5445A
 1N5446B
 1N5448B
 1N5451A
 1N5455A
 1N5456A
 1N5456B
 1N5915BRL
 1N5916B
 1N5916BRL
 1N5928BRL
 1N5939B
 1N5949B
 1N5989C
 1N5993C
 1N5995C
 1N6003C
 1N749A
 1N759A
 1N958B
 1N959B
 1N961B
 1N963B
 2N3866
 2N3866A
 2N5457RLRA
 2N5459
 2N5461RLRP
 2N5640

End of Life (Cont)

DEVICE
 2N5642
 2N5643
 2N6081
 2N6304
 2N6516
 3EZ190D5

CHANGE FROM CLASS 3

DEVICE
 BZX84C15LT1
 BZX84C33LT1
 BZX84C5V6LT1
 MJH11017
 MJH11018
 MMBD2837LT1
 MZ4622RL
 T2500DFP
 1N4686RL

DELETIONS FROM CLASS 3

DEVICE
 BCX20LT1
 MAC218-006
 MCR69-001
 MC10H118L
 MC10H119L
 MC10H171L
 MC10111L
 MC10124LD
 MC10129L
 MC10180L
 MC10211L
 MC12014L
 MC14002BCL
 MC14006BCL
 MC14022BCL
 MC14029BCL
 MC14035BCL
 MC14050BCPD
 MC14060BCPD
 MC14076BCL
 MC14077BCL
 MC14175BCPD
 MC1436CD
 MC14502BCL
 MC14514BCL
 MC14515BCL
 MC14532BCL
 MC14534BCL
 MC14547BCL
 MC14560BCL
 MC14562BCL
 MC14598BCPD
 MC3486DR2
 MC54HCT08AJ

Deletions From Class 3 (Cont)

DEVICE
 MC54HCT14AJ
 MC54HCT241AJ
 MC54HCT32AJ
 MC54HCT373AJ
 MC54HC139AJ
 MC54HC241AJ
 MC54HC368J
 MC54HC4002J
 MC54HC4016J
 MC54HC4049J
 MC54HC4050J
 MC54HC4060J
 MC54HC4351J
 MC54HC4511J
 MC54HC574AJ
 MC54HC589J
 MPS6714
 SN54LS03J
 SN54LS05J
 SN54LS09J
 SN54LS10J
 SN54LS107AJ
 SN54LS11J
 SN54LS113AJ
 SN54LS125AJ
 SN54LS126AJ
 SN54LS13J
 SN54LS133J
 SN54LS148J
 SN54LS15J
 SN54LS151J
 SN54LS153J
 SN54LS156J
 SN54LS158J
 SN54LS160AJ
 SN54LS162AJ
 SN54LS165J
 SN54LS166J
 SN54LS169J
 SN54LS173AJ
 SN54LS191J
 SN54LS192J
 SN54LS193J
 SN54LS195AJ
 SN54LS197J
 SN54LS20J
 SN54LS21J
 SN54LS241J
 SN54LS243J
 SN54LS253J
 SN54LS257BJ
 SN54LS259J
 SN54LS260J
 SN54LS266J
 SN54LS27J
 SN54LS279J
 SN54LS28J
 SN54LS290J

QUICK REFERENCE COMPONENTS

Deletions From
Class 3 (Cont)

DEVICE

SN54LS298J
SN54LS30J
SN54LS365AJ
SN54LS367AJ
SN54LS375J
SN54LS377J
SN54LS378J
SN54LS38J
SN54LS390J
SN54LS40J
SN54LS42J
SN54LS51J
SN54LS641J
SN54LS73AJ
SN54LS76AJ
SN54LS85J
SN54LS90J
SN54LS92J
SN54LS93J
SN54LS95BJ
SN74LS00J
SN74LS02J
SN74LS04J
SN74LS08J
SN74LS122J
SN74LS125AJ
SN74LS138J
SN74LS139J
SN74LS14J
SN74LS148J
SN74LS153J
SN74LS155J
SN74LS157J
SN74LS161AJ
SN74LS163AJ
SN74LS164J
SN74LS165J
SN74LS169J
SN74LS174J
SN74LS175J
SN74LS192J
SN74LS193J
SN74LS194AJ
SN74LS240J
SN74LS241J
SN74LS243J
SN74LS245J
SN74LS273J
SN74LS30J
SN74LS32J
SN74LS323J
SN74LS365AJ
SN74LS38J
SN74LS390J
SN74LS42J
SN74LS48J
SN74LS541J
SN74LS641J

Deletions From
Class 3 (Cont)

DEVICE

SN74LS645J
SN74LS688J
SN74LS73AJ
SN74LS74AJ
SN74LS85J
SN74LS86J
SN74LS92J
SN74LS93J

EFFECTIVE DATE: JANUARY 10, 1998

COMMERCIAL COMPONENTS

Type No.	Grp/Description	Per Unit Sugg. Factory					Type No.	Grp/Description	Per Unit Sugg. Factory				
		PC	Qty	Price	Order				PC	Qty	Price	Order	
AM26LS30PC	B EIA-422/423 DRIVER	2	25	1.06	500	†	BC856ALT1	A REEL PACK FOR BC856	N	3000	.096	3000	†
BAL99LT1	A SS DIODE SOT23 T/R3K	N	3000	.14	3000	†	BC856BLT1	A REEL PACK FOR BC856	2	3000	.096	3000	†
BAS116LT1	A SS DIODE SOT23 T/R3K	N	3000	.13	3000	†	BC857BLT1	A REEL PACK FOR BC857BL	N	3000	.096	3000	†
BAS16LT1	A SS DIODE SOT23 T/R3K	1	3000	.13	3000	†	BC858ALT1	A REEL PACK FOR BC858AL	2	3000	.096	3000	†
BAS16WT1	A SWITCH. DIODE, SC70 PKG	N	3000	.13	3000	†	BC858BLT1	A REEL PACK FOR BC858BL	N	3000	.096	3000	†
BAS19LT1	A SWITCHING DIO SOT-23 T/R	2	3000	.17	3000	†	BC858CLT1	A REEL PACK FOR BC858CL	2	3000	.096	3000	†
BAS21LT1	A SWITCHING DIO SOT-23 T/R	1	3000	.25	3000	†	BDW42	A PWR15A100V NPND TO220	2	50	.76	50	†
BAV170LT1	A LAST ORDER DATE:08/28/98	N	3000	.14	3000	†	BDW47	A PWR15A100V PNPDTO220	2	50	.76	50	†
BAV199LT1	A MINIBLOC SW DISER DUAL	N	3000	.14	3000	†	BD678A	A PWR4A60V PNPDC77	2	500	.39	500	
BAV70LT1	A SS COMMON CATH SOT-23 T/R	1	3000	.14	3000	†	BD779	A LAST ORDER DATE:05/13/98	3	500	2.28	500	
BAV70WT1	A COMM CATH DL SW DISC70	N	3000	.14	3000	†	BD788	A PWR4A60V PNP C77	2	500	.54	500	
BAV74LT1	A COMM CATHODE MINIBLOC	2	3000	.14	3000	†	BD809	A PWR10A80V NPND TO220	3	50	2.26	50	†
BAV99LT1	A SS DIODE SOT23 T/R3K	1	3000	.14	3000	†	BFR30LT1	A SS JFET SOT23 T/R3K	3	3000	.91	3000	†
BAV99RWT1	A REVERSE DUAL DIODE	2	3000	.14	3000	†	BFR31LT1	A SS JFET SOT23 T/R3K	3	3000	.91	3000	†
BAV99WT1	A DUAL SERIES DIODE	N	3000	.14	3000	†	BFR90	V RF NPN LO PWR MACRO-T	2	1000	.92	1000	
BAW156LT1	A MONOLITHIC DL COMMANODE	N	1000	.14	1000	†	BFR91	V RF NPN LO PWR MACRO-T	2	1000	.97	1000	
BAW56LT1	A SS ANODE SOT23 T/R3K	1	3000	.14	3000	†	BFR92ALT1	V XSTR SIL MINI BLK NPN	N	3000	.31	3000	
BAW56WT1	A COMMANODE DL SW DISC70	N	3000	.14	3000	†	BFR92LT1	V XSTR SIL MINI BLK NPN	2	3000	.46	3000	
BCP53T1	A SOT223 PNP XSTR	2	1000	.43	1000	†	BFS17LT1	V REEL PACK FOR BFS17L	2	3000	.23	3000	
BCP56T1	A SOT223 NPN XSTR	N	1000	.44	1000	†	BFY90	V RF NPN LO PWR TO-72	2	1000	1.85	1000	
BCP68T1	A SOT223 NPN XSTR	N	1000	.43	1000	†	BF720T1	A SSHI-VOLT NPN SOT-23T/R	3	1000	1.04	1000	†
BCP69T1	A SOT223 PNP XSTR	N	1000	.44	1000	†	BF720T3	A SSHI-VOLT NPN SOT-23T/R	N	4000	.59	4000	†
BCW60ALT1	A LAST ORDER DATE:08/28/98	3	3000	.34	3000	†	BF721T1	A SSHI-VOLT PNP SOT-223	3	1000	1.04	1000	†
BCW60BLT1	A SS NPN SOT23 TAPE/REEL3K	2	3000	.34	3000	†	BSP16T1	A SS AMP/SWITCH PNP SOT-223	2	1000	.50	1000	†
BCW60DLT1	A SS NPN SOT23 TAPE/REEL3K	3	3000	.34	3000	†	BSP52T1	A SS DARLINGTON NPN SOT-223	N	1000	.46	1000	†
BCW61BLT1	A SS PNP SOT23 TAPE/REEL3K	3	3000	.62	3000	†	BSS123LT1	A SS TMOS NCHAN T/R3K	1	3000	.70	3000	†
BCW61CLT1	A LAST ORDER DATE:08/28/98	3	3000	.62	3000	†	BSS138LT1	A NCHAN SOT23 MOSFET	2	3000	.36	3000	†
BCW61DLT1	A SS PNP SOT23 TAPE/REEL3K	3	3000	.33	3000	†	BSS84LT1	A P-CHAN MODE MOS PWR FET	2	3000	.36	3000	†
BCW65CLT1	A SS NPN SOT23 TAPE/REEL3K	3	3000	.53	3000	†	BS107	A SS TMOS N-CHAN T0-92	2	1000	.70	1000	†
BCX17LT1	A SS PNP SOT23 TAPE/REEL3K	3	3000	1.00	3000	†	BS107A	A SS TMOS N-CHAN T0-92	1	1000	.80	1000	†
BCX18LT1	A SS PNP SOT23 TAPE/REEL3K	3	3000	1.00	3000	†	BS170	A SS TMOS N-CHAN T0-92	1	1000	.40	1000	†
BCX19LT1	A SS NPN SOT23 TAPE/REEL3K	3	3000	.91	3000	†	BS170RLRA	A TAPE/REEL FOR BS170	2	2000	.40	2000	†
BCX70GLT1	A SS NPN SOT23 TAPE/REEL3K	3	3000	.62	3000	†	BUD43B	A NPN SILICON POW PLASTRAN	N	75	.76	75	
BCX70JLT1	A SS NPN SOT23 TAPE/REEL3K	2	3000	.14	3000	†	BUH100	A NPN SIL PLASTIC TRANS	N	50	1.02	50	
BCX70KLT1	A SS NPN SOT23 TAPE/REEL3K	3	3000	.34	3000	†	BUH150	A NPN HIGH VOLTAGE	N	50	1.70	50	
BCX71JLT1	A SS PNP SOT23 TAPE/REEL3K	3	3000	.64	3000	†	BUH50	A SILICON POWER	N	50	.82	50	
BC846ALT1	A REEL PACK FOR BC846	2	3000	.095	3000	†	BUL146	A PWR8A400V NPND TO220	2	50	.82	50	
BC846BLT1	A REEL PACK FOR BC846	2	3000	.096	3000	†	BUL44	A PWR2A400V NPND TO220	2	50	.64	50	
BC847BLT1	A XSTR SSP SOT-23 NPN	2	3000	.096	3000	†	BUL44D2	A NPN SIL PWR PLAST TRANS	N	50	.92	50	
BC847CLT1	A SMSIG XSTR MINI	2	3000	.096	3000	†	BUL44F	A LAST ORDER DATE:05/13/98	2	50	1.12	50	
BC848ALT1	A REEL PACK FOR BC848AL	N	3000	.096	3000	†	BUL45	A PWR5A400V SM TO220	2	50	1.92	50	
BC848BLT1	A SMSIG XST MINI	2	3000	.096	3000	†	BUL45D2	A NPN SIL PWR PLAST TRANS	N	50	1.42	50	
BC848CLT1	A XSTR SSP SOT-23 NPN	N	3000	.096	3000	†	BUS48AP	A PWR15A450V SM NPND TO218	3	30	7.15	30	
BC850BLT1	A REEL PACK FOR BC850BL	N	3000	.096	3000	†	BUS48P	A LAST ORDER DATE:05/13/98	3	30	6.42	30	
BC850CLT1	A REEL PACK FOR BC850CL	N	3000	.096	3000	†	BUS50	A PWR70A125V NPND TO204	2	100	13.00	100	

A = OSPD/Power
 B = Analog/Logic
 J = Transportation
 L = Consumer
 N = Networking
 V = Wireless

S = Proprietary Device
 B = Motorola Blue Chip Program Device
 P = Phoenix Program
 * = First Time in Book
 † \$200 Minimum Waived

N = Key New Motorola Device
 R = Key "Focus" Motorola Device

1 = Mature, Stable, High-Volume Device
 2 = Moderate-Volume Device
 3 = Low-Volume Device

COMMERCIAL COMPONENTS

Type No.	Grp/Description	Per Unit Sugg. Factory			Type No.	Grp/Description	Per Unit Sugg. Factory								
		Resale Price	Price	Order			Resale Price	Price	Order						
		PC	Qty	Incrmnt			PC	Qty	Incrmnt						
BUT11AF	A PWR5A400V NPN TO220FP	3	50	2.93	50	BZX84C12LT1	A	SS+5%12V ZENER SOT23	2	3000	.17	3000	†		
BUT33	A PWR56A400V NPN TO204	2	100	8.50	100	BZX84C13LT1	A	SS+5%13V ZEN T/R3K	3	3000	.43	3000	†		
BUV22	A PWR40A250V NPN TO204	2	100	6.60	100	BZX84C15LT1	A	SS+5%15V SOT23 T/R3K	2	3000	.17	3000	†		
BUV48A	A PWR15A450V NPN TO218	2	30	4.68	30	BZX84C16LT1	A	SS+5%16V SOT23 T/R3K	3	3000	.43	3000	†		
BUX48	A PWR15A400V NPN TO204	2	100	3.49	100	BZX84C20LT1	A	SS+5%20V SOT23 T/R3K	3	3000	.43	3000	†		
BUX48A	A PWR15A450V NPN TO204	2	100	3.49	100	BZX84C24LT1	A	SS+5%24V SOT23 T/R3K	3	3000	.43	3000	†		
BUX85	A PWR2A450V NPN TO220	2	50	.74	50	BZX84C27LT1	A	SS+5%27V SOT23 T/R3K	N	3000	.38	3000	†		
BUX98	A PWR30A400V NPN TO204	2	100	6.20	100	BZX84C30LT1	A	SS+5%30V SOT23 T/R3K	3	3000	.43	3000	†		
BUX98A	A PWR30A450V NPN TO204	2	100	7.30	100	BZX84C33LT1	A	SS+5%33V SOT23 T/R3K	2	3000	.30	3000	†		
BU208A	A PWR5A700V NPN TO204	2	100	2.02	100	BZX84C4V7LT1	A	SS+5%4.7V SOT23 T/R3K	3	3000	.38	3000	†		
BU323AP	A PWR10A250V NPN TO218	2	30	3.30	30	BZX84C5V1LT1	A	SS+5%5.1V SOT23 T/R3K	2	3000	.15	3000	†		
BU406	A PWR7A200V DEF NPN TO220	2	50	1.20	50	BZX84C5V6LT1	A	SS+5%5.6V SOT23 T/R3K	2	3000	.15	3000	†		
BU508A	A PWR8A700V DEF NPN TO218	3	30	6.30	30	BZX84C6V2LT1	A	SS+5%6.2V SOT23 T/R3K	2	3000	.15	3000	†		
BU806	A PWR8A200V DARNPN TO220	2	50	1.09	50	BZX84C6V8LT1	A	SS+5%6.8V SOT23 T/R3K	3	3000	.38	3000	†		
BZX55C12RL	A ZENER DIODE T/R	2	5000	.17	5000	†	BZX84C7V5LT1	A	SS+5%7.5V SOT23 T/R3K	3	3000	.68	3000	†	
BZX55C5V1RL	A ZENER DIODE T/R	2	5000	.17	5000	†	BZX84C8V2LT1	A	SS+5%8.2V SOT23 T/R3K	3	3000	.38	3000	†	
BZX55C5V6RL	A ZENER DIODE T/R	2	5000	.17	5000	†	BZX84C9V1LT1	A	SS+5%9.1V SOT23 T/R3K	3	3000	.38	3000	†	
BZX55C6V8RL	A REEL PACK FOR BZX55C6V8	2	5000	.17	5000	†	BZX85C10RL	A	ZENER DIODE T/R	2	6000	.20	6000	†	
BZX79C10RL	A ZEN10V05W5% DO35 T/RSK	N	5000	.17	5000	★	†	BZX85C12RL	A	ZENER DIODE T/R	2	6000	.20	6000	†
BZX79C100RL	A LAST ORDER DATE:03/15/98	N	5000	.17	5000	★	†	BZX85C13RL	A	ZENER DIODE T/R	2	6000	.20	6000	†
BZX79C12RL	A ZEN12V05W5% DO35 T/RSK	3	5000	.43	5000	†	BZX85C15RL	A	ZENER DIODE T/R	2	6000	.20	6000	†	
BZX79C16RL	A ZEN16V05W5% DO35 T/RSK	3	5000	.43	5000	†	BZX85C18RL	A	ZENER DIODE T/R	2	6000	.20	6000	†	
BZX79C18RL	A ZEN18V05W5% DO35 T/RSK	3	5000	.43	5000	†	BZX85C22RL	A	ZENER DIODE T/R	2	6000	.20	6000	†	
BZX79C2V4RL	A ZEN2.4V0.5W5% DO35 T/RSK	3	5000	.43	5000	†	BZX85C24RL	A	ZENER DIODE T/R	2	6000	.20	6000	†	
BZX79C2V7RL	A ZEN2.7V0.5W5% DO35 T/RSK	3	5000	.43	5000	†	BZX85C27RL	A	REEL PACK/BZX85C27	2	6000	.20	6000	†	
BZX79C20RL	A ZEN20V0.5W5% DO35 T/RSK	2	5000	.17	5000	†	BZX85C3V3RL	A	ZENER DIODE T/R	2	6000	.20	6000	†	
BZX79C22RL	A ZEN22V05W5% DO35 T/RSK	3	5000	.43	5000	†	BZX85C3V6RL	A	ZENER DIODE T/R	2	6000	.20	6000	†	
BZX79C24RL	A ZEN24V05W5% DO35 T/RSK	3	5000	.43	5000	†	BZX85C3V9RL	A	ZENER DIODE T/R	2	6000	.20	6000	†	
BZX79C27RL	A ZEN27V05W5% DO35 T/RSK	3	5000	.43	5000	†	BZX85C30RL	A	ZENER DIODE T/R	2	6000	.20	6000	†	
BZX79C3V0RL	A ZEN3.0V05W5% DO35 T/RSK	3	5000	.43	5000	†	BZX85C33RL	A	ZENER DIODE T/R	2	6000	.20	6000	†	
BZX79C3V3RL	A ZEN3.3V05W5% DO35 T/RSK	3	5000	.43	5000	†	BZX85C4V3RL	A	ZENER DIODE T/R	2	6000	.20	6000	†	
BZX79C3V6RL	A ZEN3.6V05W5% DO35 T/RSK	3	5000	.43	5000	†	BZX85C43RL	A	ZENER DIODE T/R	2	6000	.20	6000	†	
BZX79C3V9RL	A ZEN3.9V05W5% DO35 T/RSK	3	5000	.43	5000	†	BZX85C47RL	A	ZENER DIODE T/R	2	6000	.20	6000	†	
BZX79C30RL	A ZEN30V05W5% DO35 T/RSK	3	5000	.43	5000	†	BZX85C5V1RL	A	ZENER DIODE T/R	2	6000	.20	6000	†	
BZX79C33RL	A ZEN33V05W5% DO35 T/RSK	3	5000	.43	5000	†	BZX85C5V6RL	A	ZENER DIODE T/R	2	6000	.20	6000	†	
BZX79C4V3RL	A ZEN4.3V05W5% DO35 T/RSK	3	5000	.43	5000	†	BZX85C6V2RL	A	ZENER DIODE T/R	2	6000	.20	6000	†	
BZX79C4V7RL	A ZEN4.7V05W5% DO35 T/RSK	3	5000	.43	5000	†	BZX85C6V8RL	A	ZENER DIODE T/R	2	6000	.20	6000	†	
BZX79C5V1RL	A ZEN5.1V05W5% DO35 T/RSK	3	5000	.43	5000	†	BZX85C7V5RL	A	ZENER DIODE T/R	2	6000	.20	6000	†	
BZX79C5V6RL	A ZEN5.6V05W5% DO35 T/RSK	3	5000	.43	5000	†	BZX85C75RL	A	REEL PACK/BZX85C75	2	6000	.20	6000	†	
BZX79C6V2RL	A ZEN6.2V05W5% DO35 T/RSK	3	5000	.43	5000	†	BZX85C8V2RL	A	ZENER DIODE T/R	2	6000	.20	6000	†	
BZX79C6V8RL	A ZEN6.8V05W5% DO35 T/RSK	3	5000	.43	5000	†	BZX85C9V1RL	A	ZENER DIODE T/R	2	6000	.20	6000	†	
BZX79C7V5RL	A ZEN7.5V05W5% DO35 T/RSK	3	5000	.43	5000	†	CA2810C	N	RF LINEAR AMPL FLANGE PKG	2	50	53.90	50		
BZX79C8V2RL	A ZEN8.2V05W5% DO35 T/RSK	3	5000	.43	5000	†	CA2818C	N	RF LINEAR AMPL FLANGE PKG	2	50	46.20	50		
BZX79C9V1RL	A ZEN9.1V05W5% DO35 T/RSK	3	5000	.43	5000	†	CA2830C	N	5-200MHZ35DB29 DBM24V	1	50	55.44	50		
BZX84C10LT1	A SS+5%10V SOT23 T/R3K	3	3000	.43	3000	†	CA2832C	N	RF LINEAR AMPL FLANGE PKG	1	50	58.52	50		

A = OSPD/Power
 B = Analog/Logic
 J = Transportation
 L = Consumer
 N = Networking
 V = Wireless

S = Proprietary Device
 B = Motorola Blue Chip Program Device
 P = Phoenix Program
 ★ = First Time in Book
 † = \$200 Minimum Waived

N = Key New Motorola Device
 R = Key "Focus" Motorola Device

1 = Mature, Stable, High-Volume Device
 2 = Moderate-Volume Device
 3 = Low-Volume Device

COMMERCIAL COMPONENTS

Type No.	Grp/Description	PC	Qty	Per Resale Price	Sugg. Price	Factory Order Incrmt	Type No.	Grp/Description	PC	Qty	Per Resale Price	Sugg. Price	Factory Order Incrmt
CA2833C	N LAST ORDERDATE:06/19/98	N	50	55.44	50		DSP56L002FC40	N LOWPOWER24-BIT	2	36	17.27	36	B
CA2842C	N RF LINEARAMPL FLANGE PKG	2	50	49.28	50		DSP56L811ADSA	V 56L811 ADV.DEVELOPMENT	N	1	1500.08	1	S
CA3059	B LINZERO VOLT SWITCH	2	25	.65	500	†	DSP56L811ADSF	V 56L811 ADV.DEVELOPMENT	N	1	1500.08	1	S
CA4800C	N RF LINEARAMPL FLANGE PKG	2	50	54.67	50		DSP56L811EVM	V 56L811 EVALUATIONMODULE	N	1	149.00	1	S B
CA4812C	N RF LINEARAMPL FLANGE PKG	2	50	54.67	50		DSP56001AFC27	N 24-BIT FIXED POINT	1	36	19.69	36	B
CA4815C	N RF LINEARAMPL FLANGE PKG	2	50	54.67	50		DSP56001AFC33	N DSP	N	36	25.27	36	B
CA5800C	N RF LINEARAMPL FLANGE PKG	2	50	80.08	50		DSP56001AFE27	N 24-BIT FIXED POINT	N	36	23.59	36	B
CA5801	N 50-1000MHZ17DB0.4A28V	2	50	80.08	50		DSP56001AFE33	N 24-BIT FIXED POINT	N	36	26.61	36	B
CA5801S	N SHORT HEATSINK CA5801	2	50	80.08	50		DSP56001ARC27	N 24-BIT FIXED POINT	1	14	51.39	14	B
CA5815C	N RF LINEARAMPL FLANGE PKG	2	1	80.08	1		DSP56001ARC33	N 24-BIT FIXED POINT	N	14	60.86	14	B
CA901	N 17DB,860MHZ	2	50	47.74	50		DSP56002ADM	N MPG DSP	N	1	1250.06	1	S
CA901A	N 40-860MHZ17DB24V75OHM	2	50	49.28	50		DSP56002ADSA	N DEVELOPMENT SYSTEMUSER'S	2	1	1500.08	1	S
CA922	N 24VCA902	2	50	55.44	50		DSP56002ADSF	N APP DEV SYS/SUN4	2	1	1500.08	1	S
CA922A	N SPECIALIM2FORCA922	2	50	56.98	50		DSP56002EVM	N EVAL. MODULE	1	1	149.00	1	S
CNY17-001	A OPTOISO XTR6-PINDIP	1	50	.64	50	†	DSP56002FC40	N 24-BIT FIXED POINT	1	36	17.27	36	B
CNY17-002	A OPTOISO XTR6-PINDIP	2	50	.64	50	†	DSP56002FC66	N 24-BIT FIXED POINT	1	36	19.06	36	B
CNY17-003	A OPTOISO XTR6-PINDIP	1	50	.64	50	†	DSP56002PV40	N 1CMONOLITHIC40MHZDSP	N	60	16.01	60	B
CNY17-1S	A OPTOISO XTR SURF MOUNT	2	50	.74	50	†	DSP56002PV66	N DSP24-BIT TQFPFXDPT.	N	60	17.69	60	B
CNY17-1SR2	A OPTO XSTR6-PINDIPT/R	2	1000	.88	1000	†	DSP56002PV80	N DSP1CMONOLITHIC80MHZ	N	60	19.48	60	B
CNY17-1T	A OPTO ISO VDE (0.400) L/F	N	50	.74	50	†	DSP56004FJ50	L DSP24-BIT DIGITAL AUDIO	N	84	13.69	84	S B
CNY17-1TV	A OPTO ISO VDE(0.4LF)(0884)	N	50	.78	50	†	DSP56004FJ66	L 24-BIT AUDIO DSP	N	84	15.16	84	S B
CNY17-2S	A OPTOISO XTR SURF MOUNT	N	50	.72	50	†	DSP56004FJ81	L 24-BIT AUDIO DSP	N	84	18.64	84	S B
CNY17-2SR2	A OPTO XSTR6-PINDIPT/R	2	1000	.88	1000	†	DSP56009EVM	N DSP-56009 EVALUATION MODL	N	1	999.05	1	S
CNY17-2SV	A 6-PIN OPTOISOLATOR	N	50	.70	50	†	DSP56156ADM	V DEVELOPMENT MODULE BOARD	N	1	1250.06	1	S
CNY17-2T	A OPTO ISO VDE (0.400) L/F	N	50	.74	50	†	DSP56156ADSA	V DSP56156IBM-PC MACSUN3	2	1	1500.08	1	S
CNY17-2TV	A OPTO ISO VDE(0.4LF)(0884)	N	50	.74	50	†	DSP56156ADSF	V DSP56156-DEV MODULE BOARD	N	1	1500.08	1	S
CNY17-2V	A OPTO ISO VDE0884 TESTED	N	50	.74	50	†	DSP56166ADM	V APPLIC.DEV.MODULE	N	1	1250.06	1	S
CNY17-3S	A OPTOISO XTR SURF MOUNT	N	50	.74	50	†	DSP56166ADSA	V DSP56166 DEV SYSTM FOR IBM	N	1	1500.08	1	S
CNY17-3SR2	A OPTO XSTR6-PINDIPT/R	2	1000	.88	1000	†	DSP56301ADM	N DSP	N	1	1250.06	1	S
CNY17-3SV	A OPTO ISO SRF MNT VDE0884	N	50	.88	50	†	DSP56301ADSA	N DSP56301 APP DEV SYS/PC	1	1	1500.08	1	S
CNY17-3T	A OPTO ISO VDE (0.400) L/F	N	50	.74	50	†	DSP56301ADSF	N DSP56301 APP DEV SYS/SUN4	N	1	1500.08	1	S
CNY17-3TV	A OPTO ISO VDE(0.4LF)(0884)	N	50	.82	50	†	DSP56302EVM	N EVALUATION MODULE DSP	N	1	249.01	1	S
CNY17-3V	A OPTO ISO VDE0884 TESTED	N	50	.78	50	†	DSP56303EVM	N EVALUATION MODULE56303	N	1	199.01	1	S
C106B	A SCR4A200V CASE77	2	500	.36	500	†	DSP56305ADSA	N 24-BIT HIGH PERFORM.DSP	N	1	1500.08	1	S
C106D	A SCR4A400V CASE77	1	500	.40	500	†	DSP56603EVM	N EVALUATION MODULE56603	N	1	249.01	1	S
C106M	A SCR4A600V CASE77	2	500	.44	500	†	DSP96000ADSA	N 96002 DEVEL SYST-IBMPC	2	1	1500.08	1	S
C122B1	A SCR8A200V TO220	2	500	.74	500	†	D44C12	A PWR4A80V NPN TO220	3	50	1.60	50	
C122F1	A SCR8A50V TO220	2	500	.72	500	†	D44H11	A PWR10A80V PLANPNTO220	1	50	.90	50	
DSPB56007FJ50	L 24BIT AVDIO DSP	N	84	13.69	84	S B	D44H8	A PWR10A60V PLANPNTO220	2	50	.90	50	
DSPB56007FJ66	L 24BIT AUDIO DSP	N	84	15.16	84	S B	D44VH10	A PWR15A80V PLANPNTO220	2	50	1.20	50	
DSPCOMMAND	N COMMAND CONVERTER BOARD	N	1	350.02	1	S	D45C12	A PWR4A80V PNP TO220	3	50	1.60	50	
DSPE56009FJ81	L 24BIT AUDIO DSP	N	84	22.74	84	S B	D45H11	A PWR10A80V PLANPNTO220	1	50	1.10	50	
DSPPCHOST	N DSP PC HOST INTERFACE BRD	N	1	350.02	1	S	D45H8	A PWR10A60V PLANPNTO220	2	50	1.24	50	
DSPSUN4HOST	N DSP SUN4 HOST BRD	N	1	350.02	1	S	D45VH10	A PWR15A80V PLANPNTO220	1	50	1.24	50	
DSPTOOLSCD	N DEVELOPMENT SOFTWARE	N	1	99.00	1	S	H11AA1	A OPTOISO AC-XTR6-PINDIP	1	50	.86	50	†

A = OSPD/Power
 B = Analog/Logic
 J = Transportation
 L = Consumer
 N = Networking
 V = Wireless

S = Proprietary Device
 B = Motorola Blue Chip Program Device
 P = Phoenix Program
 ★ = First Time in Book
 † \$200 Minimum Waived

N = Key New Motorola Device
 R = Key "Focus" Motorola Device

1 = Mature, Stable, High-Volume Device
 2 = Moderate-Volume Device
 3 = Low-Volume Device

EFFECTIVE DATE: JANUARY 10, 1998

COMMERCIAL COMPONENTS

Type No.	Grp/Description	Per Unit Sugg.		Factory Order	Incrmnt	
		Resale Price	Price			
H11AA1S	A OPTOISOAC-XTR SURF MOUNT	2	50	1.04	50	†
H11AA1SR2	A OPTOISOAC-XTR S/M/T/R	2	1000	1.20	1000	†
H11AA1SV	A OPTOCOUPLERAC-INPUT	N	50	1.16	50	†
H11AA1TV	A OPTOCOUPLERAC-INPUT	N	50	1.16	50	†
H11AA1V	A OPTOISOAC-XTR6-PINDIP	N	50	1.12	50	†
H11AA2	A OPTOISOAC-XTR6-PINDIP	2	50	.82	50	†
H11AA3	A OPTOISOAC-XTR6-PINDIP	2	50	.90	50	†
H11AA4	A OPTOISOAC-XTR6-PINDIP	1	50	.90	50	†
H11AA4S	A OPTOISOAC-XTR SURF MOUNT	N	50	1.18	50	†
H11AA4SR2	A OPTOISOAC-XTR S/M/T/R	2	1000	1.34	1000	†
H11AA4T	A OPTOCOUPLER	N	50	1.18	50	†
H11AA4V	A OPTOCOUPLERAC-INPUT	N	50	1.18	50	†
H11AV1	A OPTOISO XTR6-PINDIP	2	50	.78	50	†
H11AV1A	A OPTOISOLATOR6-PINDIP	N	50	.80	50	†
H11AV1S	A OPTOISO XTR SURF MOUNT	2	50	.90	50	†
H11AV1SR2V	A OPTOISO XTR SURF MOUNT	2	1000	.90	1000	†
H11AV2	A OPTOISO XTR6-PINDIP	N	50	.78	50	†
H11AV2A	A OPTOISOLATOR6-PINDIP	N	50	.78	50	†
H11A1	A OPTOISO XTR6-PINDIP	1	50	.60	50	†
H11A1S	A OPTOISO XTR SURF MOUNT	N	50	.70	50	†
H11A1SR2	A OPTOCOUPLED/ISOLATOR XSTR	2	50	.70	50	†
H11A1T	A PHOTO COUPLR NPN	N	50	.70	50	†
H11A1V	A OPTOISOLATOR6-PINDIP	N	50	.70	50	†
H11A550	A OPTOISO XTR6-PINDIP	3	50	1.56	50	†
H11B1	A OPTOISO DARL6-PINDIP	1	50	.70	50	†
H11B1S	A OPTOISO DARL SURF MOUNT	N	50	.80	50	†
H11D1	A OPTOISO HVOLT6-PIN	1	50	.94	50	†
H11D1SR2	A OPTOISO HVOLT XTR S/M/T/R	2	1000	1.12	1000	†
H11D1V	A OPTOISOLATOR6-PINDIP	N	50	1.04	50	†
H11D2	A OPTOISO HVOLT6-PIN	2	50	1.04	50	†
H11D2SR2	A OPTOISO HVOLT XTR S/M/T/R	2	1000	1.12	1000	†
H11G1	A OPTOISO DARL6-PINDIP	1	50	.88	50	†
H11G1S	A OPTOISO DARL SURF MOUNT	N	50	.98	50	†
H11G1T	A OPTOCOUPLERISOLATOR	N	50	.98	50	†
H11G2	A OPTOISO DARL6-PINDIP	1	50	.88	50	†
H11G2SR2	A OPTOISO DARL S/M/T/R	2	1000	1.04	1000	†
H11G3	A OPTOISO DARL6-PINDIP	2	50	.88	50	†
H11L1	A 6-PIN SCHMIT TRIGGER OPTO	1	50	1.40	50	†
H11L1S	A 6-PIN SCHMIT TRIGGER OPTO	1	50	1.64	50	†
H11L1SR2	A 6-PIN SCHMIT TRIGGER OPTO	2	1000	1.64	1000	†
H11L1SR2V	A 6-PIN SCHMIT TRIGGER OPTO	2	1000	1.64	1000	†
H11L1SV	A 6-PIN SCHMIT TRIGGER OPTO	N	50	1.64	50	†
H11L1T	A 6-PIN SCHMIT TRIGGER OPTO	N	50	1.64	50	†
H11L1TV	A 6-PIN SCHMIT TRIGGER OPTO	N	50	1.64	50	†
H11L1V	A 6-PIN SCHMIT TRIGGER OPTO	N	50	1.64	50	†

Type No.	Grp/Description	Per Unit Sugg.		Factory Order	Incrmnt	
		Resale Price	Price			
H11L2	A 6-PIN SCHMIT TRIGGER OPTO	1	50	1.20	50	†
ICTE-005	A ZEN6.0V1500WC41-11	1	500	.69	500	†
ICTE-010	A ZEN11.7V1500WC41-11	3	500	1.36	500	†
ICTE-012	A ZEN14.1V1500WC41-11	2	500	.69	500	†
ICTE-015	A ZEN17.6V1500WC41-11	2	500	.68	500	†
ICTE-018	A ZEN21.2V1500WC41-11	2	500	.68	500	†
ICTE-036	A ZEN42.4V1500WC41-11	3	500	1.36	500	†
ICTE-12RL4	A REELPK/ICTE-12	2	1500	.69	1500	†
ICTE-15C	A ZEN17.6CLIPPER	3	500	1.92	500	†
ICTE-15RL4	A ZENERDIODE	2	1500	.68	1500	†
ICTE-22C	A ZEN25.9VCLIPPER	3	500	1.92	500	†
ICTE-5RL4	A REEL PACK FOR ICTE-5	2	1500	.69	1500	†
IRF520	A TMOSPWR100V.3R TO220	N	50	.56	50	†
IRF530	A TMOSPWR100V.160R TO220	1	50	.67	50	†
IRF540	A TMOSPWR100V.077R TO220	1	50	1.13	50	†
IRF630	A TMOSPWR200V.4R TO220	2	50	.87	50	†
IRF640	A TMOSPWR200V.18R TO220	1	50	1.20	50	†
IRF710	A TMOSPWR400V3.6R TO220	N	50	.60	50	†
IRF720	A TMOSPWR400V1.8R TO220	N	50	.57	50	†
IRF730	A TMOSPWR400V1.0R TO220	N	50	.93	50	†
IRF740	A TMOSPWR400V.55R TO220	2	50	1.32	50	†
IRF820	A TMOSPWR500V3.0R TO220	N	50	.76	50	†
IRF830	A TMOSPWR500V1.5R TO220	N	50	.93	50	†
IRF840	A TMOSPWR500V.85R TO220	2	50	1.32	50	†
J112	A SS JFET N-CHANT0-92	2	1000	.40	1000	†
J202	A LAST ORDER DATE:06/26/98	3	1000	1.40	1000	†
J309	A SS JFET N-CHANT0-92	2	1000	.54	1000	†
J310	A SS JFET N-CHANT0-92	2	1000	.54	1000	†
KITEVS11E20FN52	L KIT FOR 68HC11E2EVS	N	1	599.00	1	★S
KITITC122/D	L TMOS MICRO TOMOTO INT	N	1	145.00	1	S
KITITC127/D	L HC05MC4 MOTION CTRL	N	1	225.00	1	S
KITITC132/D	L POWERDIP MICRO/MOTOR INT	N	1	375.00	1	★S
KITITC137/D	L HC08MP16 MOTION CTRL	N	1	375.00	1	★S
KITMMEVS05P9P28	L KIT FOR 68HC05P9EVS	N	1	599.00	1	★S
LF347N	B LIN QUAD BIFET OP AMP	1	25	.57	500	†
LF351D	B LIN SINGLE BIFET OP AMP	N	98	.47	98	†
LF351DR2	B BIFET OP AMP	N	2500	.50	2500	†
LF351N	B LIN SINGLE BIFET OP AMP	2	50	.41	1000	†
LF353D	B LIN DUAL BIFET OP AMP	2	98	.47	98	†
LF353DR2	B LIN DL BIFET OP AMP T/R	2	2500	.57	2500	†
LF353N	B LIN DUAL BIFET OP AMP	1	50	.46	1000	†
LF412CD	B LIN DUAL JFET OP AMP	N	98	.85	98	†
LF412CDR2	B J-FET OP AMP	2	2500	.85	2500	†
LF412CN	B LIN DUAL JFET OP AMP	1	50	.71	1000	†
LM201AD	B LIN EXT COMP OP AMP	3	98	1.40	98	†

A = OSPD/Power
 B = Analog/Logic
 J = Transportation
 L = Consumer
 N = Networking
 V = Wireless

S = Proprietary Device
 B = Motorola Blue Chip Program Device
 P = Phoenix Program
 ★ = First Time in Book
 † = \$200 Minimum Waived

N = Key New Motorola Device
 R = Key "Focus" Motorola Device

1 = Mature, Stable, High-Volume Device
 2 = Moderate-Volume Device
 3 = Low-Volume Device

COMMERCIAL COMPONENTS

Type No.	Grp/Description	Per Unit Sugg. Factory					Type No.	Grp/Description	Per Unit Sugg. Factory						
		PC	Qty	Price	Order				PC	Qty	Price	Order			
LM211D	B LIN HI PERF VOLT COMP	2	98	.42	98	†	LM285D-1.2R2	B MICROPWR VOLT REG DIODE	2	2500	.70	2500	†		
LM211DR2	B HI VOLT COMPARATOR	N	2500	.42	2500	★	†	LM285D-2.5	B MICROPWR VOLT REG DIODE	2	98	.70	98	†	
LM224D	B LIN QUAD DIFF INPT OP AMP	N	55	.55	55	†	LM285D-2.5R2	B MICROPWR VOLT REG DIODE	2	2500	.70	2500	†		
LM224DR2	B QD LO-PWR AMP	N	2500	.55	2500	★	†	LM285Z-1.2	B LIN MICRO POWER VOLT DIODE	2	2000	.63	2000	†	
LM224N	B LIN QUAD DIFF INPT OP AMP	N	25	.48	500	†	LM285Z-1.2RA	B MICROPWR VOLT REF DIODE	N	2000	.82	2000	★	†	
LM239AD	B QUAD COMPARATOR	2	55	.58	55	†	LM285Z-2.5	B LIN MICRO POWER VOLT DIODE	1	2000	.63	2000	†		
LM239ADR2	B QUAD COMPARATOR	N	2500	.58	2500	★	†	LM285Z-2.5RA	B MICROPWR VOLT REF DIODE	N	2000	.63	2000	★	†
LM239AN	B LIN QUAD SNGL SPLY COMP	2	25	.51	500	†	LM2901D	B LIN QUAD SNGL SPLY COMP	2	55	.43	55	†		
LM239D	B LIN QUAD SNGL SPLY COMP	N	55	.55	55	†	LM2901DR2	B LIN QD SNGL SPLY COMP T/R	N	2500	.43	2500	★	†	
LM239DR2	B QD SINGLE SUPPLY COMP RTR	N	2500	.55	2500	★	†	LM2901N	B LIN QUAD SNGL SPLY COMP	1	25	.38	500	†	
LM239N	B LIN QUAD SNGL SPLY COMP	2	25	.48	500	†	LM2901VN	B QD SNGL SUP VOLT COMP	N	25	.38	500	†		
LM2574N-ADJ	B 0.5A STEP DOWN PWR SW REG	N	50	1.87	1000	†	LM2902D	B LIN QUAD LOW POW OP AMP	1	55	.43	55	†		
LM2574N-005	B 0.5A STEP DOWN PWR SW REG	N	50	1.87	1000	†	LM2902DR2	B LIN QD LOW PWR OP AMP T/R	N	2500	.43	2500	★	†	
LM2574N-012	B 0.5A STEP DOWN PWR SW REG	N	50	1.26	1000	†	LM2902N	B LIN QUAD LOW POW OP AMP	1	25	.43	500	†		
LM2574N-015	B 0.5A STEP DOWN PWR SW REG	N	50	1.87	1000	†	LM2902VD	B QUAD DIFF IN OP AMPLIFIER	N	55	.43	55	†		
LM2574N-3.3	B 0.5A STEP DOWN PWR SW REG	N	50	1.26	1000	†	LM2902VDR2	B INPUT OPER AMPLIFIER	N	2500	.43	2500	★	†	
LM2575D2T-ADJ	B 1A STEP DOWN SWITCH REGUL	N	50	3.12	500	†	LM2902VN	B QUAD DIFF IN OP AMPLIFIER	N	25	.38	500	†		
LM2575D2T-005	B 1A STEP DOWN SWITCH REGUL	N	50	3.12	500	†	LM2903D	B LIN DUAL PRECSN VOLT COMP	N	98	.43	98	†		
LM2575D2T-012	B 1A STEP DOWN SWITCH REGUL	N	50	3.12	500	†	LM2903DR2	B LIN DL PREC VOLT COMP T/R	N	2500	.43	2500	★	†	
LM2575D2T-015	B 1A STEP DOWN SWITCH REGUL	N	50	3.12	500	†	LM2903N	B LIN DUAL PRECSN VOLT COMP	1	50	.38	1000	†		
LM2575D2T-3.3	B 1A STEP DOWN SWITCH REGUL	N	50	3.12	500	†	LM2903VD	B LP OFFSET VOLT DUAL COMP	N	98	.43	98	†		
LM2575T-ADJ	B 1A STEP DOWN SWITCH REGUL	N	50	2.58	50	†	LM2903VDR2	B LP OFFSET VOLT DUAL COMP	N	2500	.43	2500	★	†	
LM2575T-005	B 1A STEP DOWN SWITCH REGUL	N	50	2.58	50	†	LM2903VN	B LP OFFSET VOLT DUAL COMP	N	50	.38	1000	†		
LM2575T-012	B 1A STEP DOWN SWITCH REGUL	N	50	2.58	50	†	LM2904D	B LIN DUAL LOW POW OP AMP	2	98	.43	98	†		
LM2575T-015	B 1A STEP DOWN SWITCH REGUL	N	50	2.58	50	†	LM2904DR2	B DL OPWR OP AMP	N	2500	.43	2500	★	†	
LM2575T-3.3	B 1A STEP DOWN SWITCH REGUL	N	50	2.58	50	†	LM2904N	B LIN DUAL LOW POW OP AMP	1	50	.38	1000	†		
LM2576D2T-ADJ	B 3A PWR SW REG WITH ON/OFF	N	50	3.78	500	†	LM2904VD	B DUAL DIFF INPUT OPER AMP	N	98	.43	98	†		
LM2576D2T-005	B 3A STEP DOWN PWR SW REGUL	N	50	3.78	500	†	LM2904VDR2	B DUAL DIFF INPUT OPER AMP	N	2500	.56	2500	★	†	
LM2576D2T-012	B 3A STEP DOWN PWR SW REGUL	N	50	3.78	500	†	LM2904VN	B DUAL DIFF INPUT OPER AMP	N	50	.38	1000	†		
LM2576D2T-015	B 3A STEP DOWN PWR SW REGUL	N	50	3.78	500	†	LM293D	B LIN DUAL PRECSN VOLT COMP	2	98	.43	98	†		
LM2576D2T-3.3	B 3A STEP DOWN PWR SW REGUL	N	50	3.78	500	†	LM293DR2	B DUAL COMPARATORS	2	2500	.47	2500	†		
LM2576T-ADJ	B 3A STEP DOWN PWR SW REGUL	N	50	3.44	50	†	LM2931ACD	B LO DRPOUT VOLT REG	N	98	.65	98	†		
LM2576T-005	B 3A STEP DOWN PWR SW REGUL	N	50	3.44	50	†	LM2931ACDR2	B LO DROP VOLT REGULATOR	2	2500	.65	2500	†		
LM2576T-012	B 3A STEP DOWN PWR SW REGUL	N	50	3.44	50	†	LM2931ACT	B LO DRPOUT VOLT REG	N	50	.58	50	†		
LM2576T-015	B 3A STEP DOWN PWR SW REGUL	N	50	3.44	50	†	LM2931ACTH	B LO DRPOUT VOLT REG	N	50	.64	50	†		
LM2576T-3.3	B 3A STEP DOWN PWR SW REGUL	N	50	3.44	50	†	LM2931ACTV	B LO DRPOUT VOLT REG	N	50	.64	50	†		
LM2576TV-ADJ	B 3A STEP DOWN PWR SW REGUL	N	50	3.44	50	†	LM2931AD-5.0	B LIN LOW DROPOUT 5V REG	2	98	.65	98	†		
LM2576TV-005	B 3A STEP DOWN PWR SW REGUL	N	50	3.44	50	†	LM2931AD-5.0R2	B LO DRPOUT VOLT REG	N	2500	.65	2500	★	†	
LM2576TV-012	B 3A STEP DOWN PWR SW REGUL	N	50	3.44	50	†	LM2931ADT-1-5.0	B LOW DROP VOLT REG	N	75	.68	75	†		
LM2576TV-015	B 3A STEP DOWN PWR SW REGUL	N	50	3.44	50	†	LM2931ADT-5.0	B VOLTAGE REGULATOR	N	75	.97	75	†		
LM2576TV-3.3	B 3A STEP DOWN PWR SW REGUL	N	50	3.44	50	†	LM2931ADT-5.0RK	B VOLTAGE REGULATOR	N	2500	1.01	2500	★	†	
LM258D	B LIN DUAL LOW POW OP AMP	N	98	.58	98	†	LM2931AD2T-5.0	B LOW DROP VOLT REG	N	50	1.18	500	†		
LM258DR2	B LIN DLOP AMP	N	2500	.58	2500	★	†	LM2931AT-5.0	B LIN LOW DROPOUT 5V REG	1	50	.58	50	†	
LM258N	B LIN DUAL LOW POW OP AMP	2	50	.51	1000	†	LM2931AZ-5.0	B LIN LOW DROPOUT 5V REG	1	2000	.57	2000	†		
LM285D-1.2	B MICROPWR VOLT REG DIODE	2	98	.70	98	†	LM2931AZ-5.0RA	B LIN LO-DRPOUT VOLT REG	N	2000	.57	2000	★	†	

A = OSPD/Power
 B = Analog/Logic
 J = Transportation
 L = Consumer
 N = Networking
 V = Wireless

S = Proprietary Device
 B = Motorola Blue Chip Program Device
 P = Phoenix Program
 ★ = First Time in Book
 † \$200 Minimum Waived

N = Key New Motorola Device
 R = Key "Focus" Motorola Device

1 = Mature, Stable, High-Volume Device
 2 = Moderate-Volume Device
 3 = Low-Volume Device

EFFECTIVE DATE: JANUARY 10, 1998

COMMERCIAL COMPONENTS

Type No.	Grp/Description	Per Unit Sugg. Factory					
		Resale Price	Price	Order			
PC	Qty	Price	Incrmnt				
LM2931AZ-5.0RP	B LINLO-DRPOUT VOLT REG	N	2000	.57	2000	★	†
LM2931CD	B LINLOWDROPOUT VOLT REG	2	98	.65	98		†
LM2931CDR2	B LINLOWDROPOUT VOLT REG	2	2500	.68	2500		†
LM2931CD2T	B LINLODROPOUT VOLT REG	N	50	1.02	500		†
LM2931CT	B LINLOWDRPT VOLT REG	2	50	.58	50		†
LM2931CTH	B LODROPOUT VOLT REG	N	50	.58	50		†
LM2931CTV	B LODROPOUT VOLT REG	N	50	.58	50		†
LM2931D-5.0	B LINLOWDROPOUT5V REG	N	98	.65	98		†
LM2931D-5.0R2	B LODRPOUT VLT REG	2	2500	.68	2500		†
LM2931DT-5.0	B VOLTAGE REGULATOR	2	75	.77	75		†
LM2931D2T-5.0	B 5V LOWDIFF REG	N	50	.75	500		†
LM2931T-5.0	B LINLOWDROPOUT5V REG	2	50	.58	50		†
LM2931Z-5.0	B LINLOWDROPOUT5V REG	2	2000	.42	2000		†
LM2931Z-5.0RA	B LINLO-DRPOUT VOLT REG	N	2000	.42	2000	★	†
LM2935D2T	B 5V LOWDIFF VOLT REG	N	50	1.48	500		†
LM2935T	B LINLO-DRPOUT DL REG	2	50	1.38	50		†
LM301AD	B LINEXT COMPOP AMP	N	98	.45	98	★	†
LM301ADR2	B LINEXP COMPOP AMP T/R	N	2500	.45	2500	★	†
LM308AD	B LINSUPERGAIN OP AMP	N	98	.62	98		†
LM308ADR2	B PREC OP AMP	N	2500	.83	2500	★	†
LM311D	B LINHI PERF VOLT COMP	1	98	.42	98		†
LM311DR2	B LINHI PERF VOLT COMP T/R	N	2500	.42	2500		†
LM311N	B LINHI PERF VOLT COMP	1	50	.36	1000		†
LM317BD2T	B ADJ1.5A POST V. REG	N	50	1.25	500		†
LM317BT	B LIN3TERM POSADJ VOLT RE	1	50	.62	50		†
LM317D2T	B POSADJ VOLT REG	N	50	1.25	500		†
LM317D2TR4	B POSADJ VOLT REG	N	800	1.72	800	★	†
LM317LBD	B LIN100MA3TRM VOLT REG	2	98	.42	98		†
LM317LBDR2	B LIN100MA3TRM VOLT REG	2	2500	.53	2500		†
LM317LBZ	B 100MA VOLT REG	N	2000	.42	2000		†
LM317LBZRA	B 100MA VOLT REG	N	2000	.42	2000	★	†
LM317LBZRP	B 100MA VOLT REG	N	2000	.42	2000	★	†
LM317LD	B LIN100MA3TRM VOLT REG	2	98	.42	98		†
LM317LDR2	B LIN VOLT REG	2	2500	.39	2500		†
LM317LZ	B LINLOWCURRADJ POS REG	1	2000	.42	2000		†
LM317LZRA	B POSADJ VOLT REG	2	2000	.42	2000		†
LM317LZRE	B 100MA3-TPOSADJ REG	N	2000	.42	2000	★	†
LM317LZRP	B LINLOWCURRADJ POS REG	N	2000	.42	2000	★	†
LM317MABDT	B MEDCURRENT POSADJ VREG	2	75	.97	75		†
LM317MABDT-001	B MEDCURRENT POSADJ VREG	N	75	.65	75		†
LM317MABDTRK	B MEDCURRENT POSADJ VREG	N	2500	1.20	2500		†
LM317MABT	B VOLT REG	2	50	.62	50		†
LM317MADT	B MEDCURRENT POSADJ VREG	2	75	.97	75		†
LM317MADT-001	B MEDCURRENT POSADJ VREG	N	75	.65	75		†
LM317MADTRK	B MEDCURRENT POSADJ VREG	N	2500	1.08	2500		†

Type No.	Grp/Description	Per Unit Sugg. Factory					
		Resale Price	Price	Order			
PC	Qty	Price	Incrmnt				
LM317MAT	B MEDCURRENT POSADJ VREG	2	50	.62	50		†
LM317MBDT	B MEDCURRENT POSADJ VREG	2	75	.65	75		†
LM317MBDT-001	B MEDCURRENT POSADJ VREG	N	75	.65	75		†
LM317MBDTRK	B MEDCURRENT POSADJ VREG	N	2500	1.14	2500		†
LM317MBT	B ADV POS VOLT REG	2	50	.62	50		†
LM317MDT	B LINADV. POS. VOLT. REG	1	75	.97	75		†
LM317MDT-001	B LINADV. POS. VOLT. REG	2	75	.65	75		†
LM317MDTRK	B ADJ POS VOLTAGE REG	N	2500	1.01	2500		†
LM317MT	B LINMED CURRADJ POS REG	2	50	.62	50		†
LM317T	B LINADJ POS VOLT REG	1	50	.62	50		†
LM323AT	B LIN3 AMP5V POS VOLT REG	2	50	2.73	50		†
LM323T	B LIN3 AMP5V POS VOLT REG	2	50	2.73	50		†
LM324AD	B LINQUAD LOW POWER OP AMP	2	55	.37	55		†
LM324ADR2	B QDLO-PWR OP AMP	2	2500	.43	2500		†
LM324AN	B LINQUAD LOW POWER OP AMP	1	25	.32	500		†
LM324D	B LINQUAD LOW POWER OP AMP	1	55	.37	55		†
LM324DR2	B LINQD LOW PWR OP AMP T/R	1	2500	.43	2500		†
LM324N	B LINQUAD LOW POWER OP AMP	1	25	.32	500		†
LM337AT	B 3TERM NEG ADJ REG	2	50	.80	50		†
LM337BD2T	B ADJ NEG VOLT REG	N	50	1.59	500		†
LM337BD2TR4	B ADJ NEG VOLT REG	2	800	1.48	800		†
LM337BT	B LIN3-TERM NEG VOLT REG	2	50	.80	50		†
LM337D2T	B ADJ NEG VOLT REG	N	50	1.44	500		†
LM337MT	B LINMED CURRADJ NEG REG	2	50	.80	50		†
LM337T	B LINADJ NEG VOLT REG	1	50	.80	50		†
LM339AD	B LINQUAD SNGL SPLY COMP	2	55	.37	55		†
LM339ADR2	B LINCOMPARATOR	N	2500	.47	2500	★	†
LM339AN	B LINQUAD SNGL SPLY COMP	1	25	.32	500		†
LM339D	B LINQUAD SNGL SPLY COMP	1	55	.37	55		†
LM339DR2	B LINQD SNGL SPLY COMP T/R	1	2500	.40	2500		†
LM339N	B LINQUAD SNGL SPLY COMP	1	25	.32	500		†
LM340AT-012	B LIN3-TERM POS12V REG	2	50	.51	50		†
LM340AT-015	B LIN3-TERM POS15V REG	2	50	.51	50		†
LM340AT-5.0	B LIN3-TERM POS5V REG	2	50	.51	50		†
LM340T-012	B LIN3-TERM POS12V REG	2	50	.58	50		†
LM340T-015	B LIN3-TERM POS15V REG	2	50	.58	50		†
LM340T-018	B LIN3-TERM POS18V REG	3	50	1.40	50		†
LM340T-024	B LIN3-TERM POS24V REG	N	50	.51	50		†
LM340T-5.0	B LIN3-TERM POS5V REG	1	50	.58	50		†
LM340T-6.0	B LIN3-TERM POS6V REG	3	50	1.40	50		†
LM340T-8.0	B LIN3-TERM POS8V REG	N	50	.51	50		†
LM348D	B LIN(QUAD MC1741) OP AMP	N	55	.67	55		†
LM348DR2	B QD MC1741 OP AMP	2	2500	.70	2500		†
LM350BT	B 3AMP POSADJ REG	N	50	2.18	50		†
LM350T	B LINADJ POS VOLT REG	1	50	1.81	50		†

A = OSPD/Power
 B = Analog/Logic
 J = Transportation
 L = Consumer
 N = Networking
 V = Wireless

S = Proprietary Device
 B = Motorola Blue Chip Program Device
 P = Phoenix Program
 ★ = First Time in Book
 † \$200 Minimum Waived

N = Key New Motorola Device
 R = Key "Focus" Motorola Device

1 = Mature, Stable, High-Volume Device
 2 = Moderate-Volume Device
 3 = Low-Volume Device

COMMERCIAL COMPONENTS

Type No.	Grp/Description	Per Unit Sugg. Factory		Order		Type No.	Grp/Description	Per Unit Sugg. Factory		Order			
		PC	Qty					Price	Price			PC	Qty
LM358D	B LIN DUAL LOW POW OP AMP	1	98	.37	98	†	LP2951ACD-3.0	B POS LO VOLT DRP OUT REG	N	98	1.33	98	†
LM358DR2	B LIN DL LOW PWR OP AMP T/R	1	2500	.40	2500	†	LP2951ACD-3.0R2	B POS LO VOLT DRP OUT REG	2	2500	1.33	2500	†
LM358N	B LIN DUAL LOW POW OP AMP	1	50	.32	1000	†	LP2951ACD-3.3	B POS LO VOLT DRP OUT REG	N	98	1.33	98	†
LM385BD-1.2	B MICROPWR VOLT REF DIODE	1	98	.70	98	†	LP2951ACD-3.3R2	B POS LO VOLT DRP OUT REG	2	2500	1.33	2500	†
LM385BD-1.2R2	B MICROPWR VOLT REF DIODE	2	2500	.73	2500	†	LP2951ACDM	B POS LO VOLT DRP OUT REG	N	2500	1.83	2500	†
LM385BD-2.5	B MICROPWR VOLT REF DIODE	2	98	.70	98	†	LP2951ACDM-3.0	B POS LO VOLT DRP OUT REG	N	2500	1.23	2500	†
LM385BD-2.5R2	B MICROPWR VOLT REF DIODE	2	2500	.70	2500	†	LP2951ACDM-3.3	B POS LO VOLT DRP OUT REG	N	2500	1.23	2500	†
LM385BZ-1.2	B LIN MCRPWR VOLT REF DIODE	1	2000	.63	2000	†	LP2951ACDM-5.0	B POS LO VOLT DRP OUT REG	N	2500	1.23	2500	†
LM385BZ-1.2RA	B MICROPWR VOLT REF DIODE	N	2000	.73	2000	†	LP2951ACN	B POS LO VOLT DRP OUT REG	N	50	1.12	1000	†
LM385BZ-2.5	B LIN MCRPWR VOLT REF DIODE	1	2000	.63	2000	†	LP2951ACN-3.0	B POS LO VOLT DRP OUT REG	N	50	1.12	1000	†
LM385D-1.2	B LIN MCRPWR VOLT REF DIODE	1	98	.63	98	†	LP2951ACN-3.3	B POS LO VOLT DRP OUT REG	N	50	1.12	1000	†
LM385D-1.2R2	B LIN MCRPWR REF DIODE T/R	2	2500	.67	2500	†	LP2951CD	B POS LO VOLT DRP OUT REG	N	98	1.06	98	†
LM385D-2.5R2	B LIN MCRPWR REF DIODE T/R	2	2500	.67	2500	†	LP2951CD-3.0	B POS LO VOLT DRP OUT REG	N	98	1.22	98	†
LM385Z-1.2	B LIN MCRPWR VOLT REF DIODE	1	2000	.63	2000	†	LP2951CD-3.0R2	B POS LO VOLT DRP OUT REG	2	2500	1.22	2500	†
LM385Z-1.2RA	B MICROPWR VOLT REF DIODE	2	2000	.67	2000	†	LP2951CD-3.3	B POS LO VOLT DRP OUT REG	N	98	1.22	98	†
LM385Z-2.5	B LIN MCRPWR VOLT REF DIODE	1	2000	.63	2000	†	LP2951CD-3.3R2	B POS LO VOLT DRP OUT REG	2	2500	1.22	2500	†
LM393AN	B LIN DUAL PRCSN VOLT COMP	1	50	.32	1000	†	LP2951CDM	B POS LO VOLT DRP OUT REG	N	2500	1.13	2500	†
LM393D	B LIN DUAL PRCSN VOLT COMP	1	98	.37	98	†	LP2951CDM-3.0	B POS LO VOLT DRP OUT REG	N	2500	1.13	2500	†
LM393DR2	B LIN DL PREC VOLT COMP T/R	1	2500	.40	2500	†	LP2951CDM-3.3	B POS LO VOLT DRP OUT REG	N	2500	1.13	2500	†
LM393N	B LIN LO PWR DL COMPARATOR	1	50	.32	1000	†	LP2951CDM-5.0	B POS LO VOLT DRP OUT REG	N	2500	1.13	2500	†
LM833D	B LIN D LO-NOISE AUDIO AMP	N	98	.70	98	†	LP2951CN	B POS LO VOLT DRP OUT REG	N	50	1.03	1000	†
LP2950ACDT-3.0	B POS LO VOLT DRP OUT REG	N	75	1.47	75	†	LP2951CN-3.0	B POS LO VOLT DRP OUT REG	N	50	1.03	1000	†
LP2950ACDT-3.0RK	B POS LO VOLT DRP OUT REG	2	2500	1.47	2500	†	LP2951CN-3.3	B POS LO VOLT DRP OUT REG	N	50	1.03	1000	†
LP2950ACDT-3.3	B POS LO VOLT DRP OUT REG	N	75	1.47	75	†	L4949D	B MULTIF NEW LOW DROP REGUL	N	98	1.31	98	†
LP2950ACDT-3.3RK	B POS LO VOLT DRP OUT REG	2	2500	1.47	2500	†	L4949N	B MULTIF NEW LOW DROP REGUL	N	50	1.31	1000	†
LP2950ACDT-5.0	B POS LO VOLT DRP OUT REG	N	75	1.47	75	†	MAC08MT1	A SOT223 TRIAC	2	1000	.72	1000	†
LP2950ACDT-5.0RK	B POS LO VOLT DRP OUT REG	2	2500	1.47	2500	†	MAC12D	A THY, TRIAC12A, 400, 600, 800V	N	50	.86	50	†
LP2950ACZ-3.0	B POS LO VOLT DRP OUT REG	N	2000	1.07	2000	†	MAC12M	A THY, TRIAC12A, 400, 600, 800V	N	50	.88	50	†
LP2950ACZ-3.0RA	B POS LO VOLT DRP OUT REG	2	2000	1.07	2000	†	MAC12N	A THY, TRIAC12A, 400, 600, 800V	N	50	.92	50	†
LP2950ACZ-3.3	B POS LO VOLT DRP OUT REG	N	2000	1.07	2000	†	MAC15-008	A TRIAC15A600V TO220	2	500	1.22	500	†
LP2950ACZ-3.3RA	B POS LO VOLT DRP OUT REG	2	2000	1.07	2000	†	MAC15-010	A TRIAC15A800V TO220	3	500	2.07	500	†
LP2950ACZ-5.0	B POS LO VOLT DRP OUT REG	N	2000	1.07	2000	†	MAC15A10	A TRIAC15A800V TO220	2	500	1.28	500	†
LP2950ACZ-5.0RA	B POS LO VOLT DRP OUT REG	2	2000	1.07	2000	†	MAC15A10FP	A TRIAC15A800V ISO TO220	2	500	1.80	500	†
LP2950CDT-3.0	B POS LO VOLT DRP OUT REG	N	75	1.35	75	†	MAC15A6	A TRIAC15A400V TO220	2	500	1.20	500	†
LP2950CDT-3.0RK	B POS LO VOLT DRP OUT REG	2	2500	1.27	2500	†	MAC15A6FP	A TRIAC15A400V ISO TO220	2	500	1.56	500	†
LP2950CDT-3.3	B POS LO VOLT DRP OUT REG	N	75	1.35	75	†	MAC15A8	A TRIAC15A600V TO220	2	500	1.22	500	†
LP2950CDT-3.3RK	B POS LO VOLT DRP OUT REG	2	2500	1.27	2500	†	MAC15A8FP	A TRIAC15A600V ISO TO220	2	500	1.64	500	†
LP2950CDT-5.0	B POS LO VOLT DRP OUT REG	N	75	1.35	75	†	MAC15M	A TRIAC TO22015A	N	50	1.08	50	†
LP2950CZ-3.0	B POS LO VOLT DRP OUT REG	N	2000	.95	2000	†	MAC15N	A TRIAC TO22015A	N	50	1.12	50	†
LP2950CZ-3.0RA	B POS LO VOLT DRP OUT REG	2	2000	.95	2000	†	MAC15SD	A XSTR, TRIAC, 15A, SENGATE	N	50	1.10	50	†
LP2950CZ-3.3	B POS LO VOLT DRP OUT REG	N	2000	.95	2000	†	MAC15SM	A XSTR, TRIAC, 15A, SENGATE	N	50	1.12	50	†
LP2950CZ-3.3RA	B POS LO VOLT DRP OUT REG	2	2000	.95	2000	†	MAC15SN	A XSTR, TRIAC, 15A, SENGATE	N	50	1.16	50	†
LP2950CZ-5.0	B POS LO VOLT DRP OUT REG	N	2000	.95	2000	†	MAC16D	A 16AMP TO220 TRIAC	N	50	1.06	50	†
LP2950CZ-5.0RA	B POS LO VOLT DRP OUT REG	2	2000	.95	2000	†	MAC16M	A 16AMP TO220 TRIAC	N	50	1.08	50	†
LP2951ACD	B POS LO VOLT DRP OUT REG	N	98	1.33	98	†	MAC16N	A 16AMP TO220 TRIAC	N	50	1.12	50	†

A = OSPD/Power
 B = Analog/Logic
 J = Transportation
 L = Consumer
 N = Networking
 V = Wireless

S = Proprietary Device
 B = Motorola Blue Chip Program Device
 P = Phoenix Program
 ★ = First Time in Book
 † \$200 Minimum Waived

N = Key New Motorola Device
 R = Key "Focus" Motorola Device

1 = Mature, Stable, High-Volume Device
 2 = Moderate-Volume Device
 3 = Low-Volume Device

EFFECTIVE DATE: JANUARY 10, 1998

COMMERCIAL COMPONENTS

Type No.	Grp/Description	Per Unit Sugg.		Factory Order	Incrmnt	
		Resale Price	Price			
MAC210-008	A TRIAC10A600VTO220	N	500	.94	500	†
MAC210A10FP	A TRIAC10A800VISO TO220	3	500	2.31	500	†
MAC210A8	A TRIAC10A600VTO220	2	500	1.08	500	†
MAC210A8FP	A TRIAC10A600VISO TO220	2	500	1.36	500	†
MAC212A10	A TRIAC12A800VTO220	3	500	1.73	500	†
MAC212A10FP	A TRIAC12A800VISO TO220	3	500	3.70	500	†
MAC212A6FP	A TRIAC12A400VISO TO220	3	500	3.04	500	†
MAC212A8	A TRIAC12A600VTO220	3	500	1.96	500	†
MAC212A8FP	A TRIAC12A600VISO TO220	2	500	1.94	500	†
MAC218A10FP	A TRIAC8A800VISO TO220	2	500	1.50	500	†
MAC218A8	A TRIAC8A600V TO220	3	500	1.80	500	†
MAC223A10	A TRIAC25A800V TO220	2	500	2.00	500	†
MAC223A10FP	A TRIAC25A800VISO TO220	2	500	2.06	500	†
MAC223A6	A TRIAC25A400VTO220	2	500	1.80	500	†
MAC223A6FP	A TRIAC25A400VISO TO220	1	500	1.90	500	†
MAC223A8	A TRIAC25A600V TO220	1	500	1.90	500	†
MAC223A8FP	A TRIAC25A600VISO TO220	1	500	1.98	500	†
MAC224A10	A TRIAC40A800V TO220	2	500	2.70	500	†
MAC224A4	A TRIAC40A200V TO220	2	500	2.50	500	†
MAC224A6	A TRIAC40A400V TO220	2	500	2.54	500	†
MAC224A8	A TRIAC40A600V TO220	1	500	2.60	500	†
MAC228A10	A TRIAC8A800V TO220	2	500	1.70	500	†
MAC228A4	A TRIAC8A200V TO220	2	500	1.08	500	†
MAC228A6	A TRIAC8A400V TO220	1	500	1.18	500	†
MAC228A8	A TRIAC8A600V TO220	2	500	1.52	500	†
MAC229A6	A TRIAC8A400V TO220	3	500	3.39	500	†
MAC229A8FP	A TRIAC8A600V TO220FP	N	500	1.66	500	†
MAC3030-008	A TRIAC8A250TO220	2	500	1.20	500	†
MAC320A8FP	A TRIAC20A600VISO TO220	2	500	1.74	500	†
MAC4DHMT4	A THYRISTOR DPAK, TRIAC, 4A	N	2500	.62	2500	†
MAC4DSMT4	A THYRISTOR DPAK, TRIAC, 4A	N	2500	.62	2500	†
MAC8D	A 8A TO220 TRIAC	N	50	.82	50	†
MAC8M	A 8A TO220 TRIAC	N	50	.84	50	†
MAC8N	A 8A TO220 TRIAC	N	50	.88	50	†
MAC8SD	A XSTR, TRIAC, 8.0A, SENGATE	N	50	.82	50	†
MAC8SM	A XSTR, TRIAC, 8.0A, SENGATE	N	50	.84	50	†
MAC8SN	A XSTR, TRIAC, 8.0A, SENGATE	N	50	.88	50	†
MAC9D	A 8A TO220 TRIAC	N	50	.82	50	†
MAC9M	A 8A TO220 TRIAC	N	50	.84	50	†
MAC9N	A 8A TO220 TRIAC	N	50	.88	50	†
MAC97-008	A TRIAC.6A600VTO92	3	5000	.82	5000	†
MAC97A4	A TRIAC.6A200VTO92	1	5000	.32	5000	†
MAC97A6	A TRIAC.6A400VTO92	1	5000	.34	5000	†
MAC97A6RLRP	A THYRISTOR TRIAC	N	2000	.26	2000	★
MAC97A8	A TRIAC.6A600VTO92	1	5000	.44	5000	†

Type No.	Grp/Description	Per Unit Sugg.		Factory Order	Incrmnt	
		Resale Price	Price			
MAD1103P	A LAST ORDER DATE:06/26/98	1	25	2.64	25	†
MAD1107P	A LAST ORDER DATE:06/26/98	2	25	2.82	25	†
MAD1108P	A LAST ORDER DATE:06/26/98	1	25	2.46	25	†
MAD1109P	A LAST ORDER DATE:06/26/98	2	25	4.92	25	†
MAD130P	A LAST ORDER DATE:06/26/98	2	25	4.90	25	†
MBD101	A SS HOT CARRIER DIODE TO92	2	1000	.36	1000	†
MBD110DWT1	A SCHOTTKY SOT-363/SC-706L	2	3000	.29	3000	†
MBD301	A SS HOT CARRIER DIODE TO92	1	1000	.40	1000	†
MBD330DWT1	A DSCHTKY SOT-363/SC-706L	N	3000	.11	3000	†
MBD701	A SS HOT CARRIER DIODE TO92	2	1000	.40	1000	†
MBD770DWT1	A DL SCKY SOT-363/SC-706L	N	3000	.11	3000	†
MBRA130LT3	A RECT1.0A,30V,SBR,SMA	2	5000	.50	5000	†
MBRA140T3	A RECT,SCHOTTKY	2	5000	.36	5000	†
MBRB1545CT	A REC15A45V SBR D2PAK	2	50	2.20	50	†
MBRB1545CTT4	A REC15A45V SBR D2PAK	2	800	1.71	800	†
MBRB20100CT	A REC20A100V SBR D2PAK	2	50	3.90	50	†
MBRB20100CTT4	A REC20A100V SBR D2PAK	2	800	2.95	800	†
MBRB20200CT	A REC20A200V SBR D2PAK	N	50	3.90	50	†
MBRB20200CTT4	A REC20A200V SBR D2PAK	N	800	3.02	800	†
MBRB2060CT	A REC20A60V SBR D2PAK	2	50	3.80	50	†
MBRB2060CTT4	A REC20A60V SBR D2PAK	N	800	2.95	800	†
MBRB2515L	A REC25A15V LOVF D2PAK	2	50	3.80	50	†
MBRB2515LT4	A REC25A15V LOVF D2PAK	2	800	2.95	800	†
MBRB2535CTL	A REC25A35V LOVF D2PAK	2	50	3.36	50	†
MBRB2535CTLT4	A REC25A35V SBR D2PAK	2	800	2.60	800	†
MBRB2545CT	A REC30A45V SBR D2PAK	2	50	3.20	50	†
MBRB2545CTT4	A REC30A45V SBR D2PAK	2	800	2.48	800	†
MBRB3030CTL	A RECT30A30V SBR D2PAK	N	50	3.60	50	†
MBRB3030CTLT4	A RECT30A30V SBR D2PAK	N	800	2.79	800	†
MBRB3030CTT4	A REC30A30V SBR D2PAK	N	800	2.56	800	†
MBRB4030	A RECT40A30V SBR D2PAK	N	50	3.60	50	†
MBRB4030T4	A RECT40A30V SBR D2PAK	N	800	2.79	800	†
MBRD1035CTL	A REC10A35V LOVF SBR DPAK	N	75	1.30	75	†
MBRD1035CTLT4	A REC10A35V LOVF SBR DPAK	N	2500	1.01	2500	†
MBRD320	A REC3A20V SCHOTT DPAK	2	75	1.10	75	†
MBRD320T4	A REC3A20V SBR DPAK	2	2500	.79	2500	†
MBRD330	A REC3A30V SCHOTT DPAK	3	75	1.86	75	†
MBRD330T4	A REC3A30V DPAK	2	2500	.77	2500	†
MBRD340T4	A REC3A40V SBR DPAK	1	2500	.77	2500	†
MBRD350	A REC3A50V SCHOTT DPAK	3	75	1.86	75	†
MBRD360	A REC3A60V SCHOTT DPAK	3	75	1.86	75	†
MBRD360-001	A REC3A60V SCHOTT DPAK	3	75	3.28	75	†
MBRD360T4	A REC3A60V SBR DPAK	2	2500	.77	2500	†
MBRD620CTT4	A REC6A20V SCHOTT DPCKT/R	2	2500	.99	2500	†
MBRD640CT	A REC6A40V SCHOTT DPAK	2	75	1.38	75	†

A = OSPD/Power
 B = Analog/Logic
 J = Transportation
 L = Consumer
 N = Networking
 V = Wireless

S = Proprietary Device
 B = Motorola Blue Chip Program Device
 P = Phoenix Program
 ★ = First Time in Book
 † \$200 Minimum Waived

N = Key New Motorola Device
 R = Key "Focus" Motorola Device

1 = Mature, Stable, High-Volume Device
 2 = Moderate-Volume Device
 3 = Low-Volume Device

EFFECTIVE DATE: JANUARY 10, 1998

COMMERCIAL COMPONENTS

Type No.	Grp/Description	Per PC	Unit Qty	Sugg. Resale Price	Factory Order Price	Order Incrmnt	Type No.	Grp/Description	Per PC	Unit Qty	Sugg. Resale Price	Factory Order Price	Order Incrmnt
MBRD640CTT4	A REC6A40V SCHOTT DPKT/R	2	2500	.99	2500	†	MBR1045	A REC10A45V SCHOTT TO220	1	50	1.40	50	†
MBRD650CT	A REC6A50V SCHOTT DPAK	3	75	3.17	75	†	MBR1060	A REC10A60V SCHOTT TO220	1	50	1.40	50	†
MBRD660CT	A REC6A60V SCHOTT DPAK	1	75	1.38	75	†	MBR1090	A REC10A90V SCHOTT TO220	2	50	1.80	50	†
MBRD660CTT4	A REC6A60V SCHOTT DPKT/R	2	2500	.99	2500	†	MBR1100	A REC1A100V SCHOTT AXIAL	1	1000	.43	1000	†
MBRD660CT1	A REC6A60V SCHOTT DPAK	2	75	1.38	75	†	MBR1100RL	A REC1A100V SCHOTT AXIAL	2	5000	.60	5000	†
MBRD835L	A REC8A35V SBR DPAK LO VF	N	75	1.10	75	†	MBR120P	A REC1A20V SCHOTT AXIAL	2	1000	.21	1000	†
MBRD835LT4	A REC3A35V SBR DPAK LO VF	N	2500	.79	2500	†	MBR130PRL	A REC1A30V SBR AXIAL	2	5000	.21	5000	†
MBRF1545CT	A REC15A45V SBR220FP	N	50	1.80	50	†	MBR140PRL	A REC1A40V SBR AXIAL	2	5000	.21	5000	†
MBRF20100CT	A REC20A100V SBR220FP	N	50	3.10	50	†	MBR150	A REC1A50V SCHOTT AXIAL	2	1000	.36	1000	†
MBRF20200CT	A REC20A200V SBR220FP	N	50	3.20	50	†	MBR150RL	A REC1A50V SBR AXIAL	2	5000	.36	5000	†
MBRF2060CT	A REC20A60V SBR220FP	N	50	2.80	50	†	MBR1535CT	A REC15A35V SCHOTT TO220	1	50	1.50	50	†
MBRF2545CT	A REC25A45V SBR220FP	1	50	2.50	50	†	MBR1545CT	A REC15A45V SCHOTT TO220	1	50	1.20	50	†
MBRF745	A REC7.5A45V SBR220FP	N	50	1.50	50	†	MBR160	A REC1A60V SCHOTT AXIAL	1	1000	.36	1000	†
MBRM5817T3	A 1A,20V,MICROSEMIPWRMITE	R12000		.44	12000	†	MBR160RL	A REC1A60V SBR AXIAL	1	5000	.36	5000	†
MBRM5819T3	A 1A40V,MICROSEMIPWRMITE	R12000		.46	12000	†	MBR1635	A REC16A35V SCHOTT TO220	1	50	1.38	50	†
MBRP20030CTL	A REC200A30V SBR PWR TAP	N	1	39.00	1	†	MBR1645	A REC16A45V SCHOTT TO220	1	50	1.38	50	†
MBRP20035L	A RECTIFIER SCHOTT KY	N	50	18.00	50	†	MBR20100CT	A REC20A100V SBR220	1	50	3.00	50	†
MBRP20045CT	A REC200A45V SBR PT II	N	25	35.10	25	†	MBR20200CT	A REC20A200V SCHOTT TO220	2	50	3.50	50	†
MBRP20060CT	A REC200A60V SBR PT II	N	1	37.70	1	†	MBR2030CTL	A REC20A30V SBR220	2	50	2.70	50	†
MBRP30035L	A RECT,SCHOTT KY,300A,35V	N	50	20.00	50	†	MBR2045CT	A REC20A45V SCHOTT TO220	1	50	1.54	50	†
MBRP30045CT	A REC300A45V SBR PT II	1	25	39.00	25	†	MBR2060CT	A REC20A60V SCHOTT TO220	2	50	2.00	50	†
MBRP30060CT	A REC300A60V SBR PT II	N	25	41.60	25	†	MBR2080CT	A REC20A80V SCHOTT TO220	2	50	2.60	50	†
MBRP60035CTL	A REC600A35V SBR PT II	1	25	70.00	25	†	MBR2090CT	A REC20A90V SCHOTT TO220	2	50	2.60	50	†
MBRS1100T3	A REC1A100V SBR SMB	1	2500	.60	2500	†	MBR2515L	A REC25A15V SBR TO220	N	50	3.30	50	†
MBRS120T3	A REC1A20V SBR SMB	1	2500	.47	2500	†	MBR2535CT	A REC30A35V SCHOTT TO220	1	50	2.20	50	†
MBRS130LT3	A REC1A30V SBR SMB	1	2500	.53	2500	†	MBR2535CTL	A REC30A35V SCHOTKY TO220	2	50	2.90	50	†
MBRS130T3	A REC1A30V SBR SMB	1	2500	.47	2500	†	MBR2545CT	A REC30A45V SCHOTT TO220	1	50	2.10	50	†
MBRS140LT3	A RECT,SURF MT,1A,40V,L/VF	N	2500	.47	2500	†	MBR3045PT	A REC30A45V SCHOTT TO218	1	30	4.00	30	†
MBRS140T3	A REC1A40V SBR SMB	1	2500	.47	2500	†	MBR3045ST	A REC30A45V SBR TO220	N	50	2.30	50	†
MBRS190T3	A REC1A90V SBR SMB	3	2500	1.86	2500	†	MBR3045WT	A REC30A45V SBR247	3	30	7.85	30	†
MBRS2040LT3	A RECT,SURF MT,2.0A,40V	N	2500	.53	2500	†	MBR3100	A REC3A100V SCHOTT AXIAL	1	500	.78	500	†
MBRS240LT3	A RECT,2.0A,40V,SURFACE MT	2	2500	.57	2500	†	MBR340	A REC3A40V SCHOTT AXIAL	2	500	.71	500	†
MBRS240T3	A RECT,2.0A,40V,SURFACE MT	N	2500	.51	2500	†	MBR340P	A REC3A40V SCHOTT AXIAL	2	500	.91	500	†
MBRS320T3	A REC3A20V SBR SMC	2	2500	.44	2500	†	MBR340PRL	A REC3A40V SBR AXIAL	2	1500	.84	1500	†
MBRS330T3	A REC3A30V SBR SMC	1	2500	.44	2500	†	MBR340RL	A REC3A40V SBR AXIAL	3	1500	1.96	1500	†
MBRS340T3	A REC3A40V SBR SMC	1	2500	.44	2500	†	MBR350RL	A REC3A50V SBR AXIAL	2	1500	.72	1500	†
MBRS360T3	A REC3A60V SMC	N	2500	.44	2500	†	MBR360	A REC3A60V SCHOTT AXIAL	1	500	.60	500	†
MBR0520LT1	A REC0.5A20V LOVF SOD123	1	3000	.19	3000	†	MBR360RL	A REC3A60V SBR AXIAL	2	1500	.56	1500	†
MBR0520LT3	A REC0.5A20V LOVF SOD123	N10000		.19	10000	†	MBR390	A REC3A90V SCHOTT AXIAL	2	500	.91	500	†
MBR0530T1	A REC0.5A30V SOD123	N	3000	.19	3000	†	MBR4015LWT	A REC40A15V LVF TO247	N	30	5.14	30	†
MBR0530T3	A REC0.5A30V SOD123	N10000		.19	10000	†	MBR4045PT	A REC40A45V SBR TO218	N	30	4.40	30	†
MBR0540T1	A REC0.5A40V SOD123	N	3000	.19	3000	†	MBR4045WT	A REC40A45V SBR TO247	2	30	4.72	30	†
MBR0540T3	A REC0.5A40V SOD123	N10000		.19	10000	†	MBR5025L	A REC50A,25V SCHOTT TO-218	2	30	5.56	30	†
MBR10100	A REC10A100V SCHOTT TO220	1	50	1.80	50	†	MBR6045PT	A REC60A45V SBR TO218	N	30	5.60	30	†
MBR1035	A REC10A35V SCHOTT TO220	1	50	1.40	50	†	MBR6045WT	A REC60A45V SBR TO247	2	30	5.60	30	†

A = OSPD/Power
 B = Analog/Logic
 J = Transportation
 L = Consumer
 N = Networking
 V = Wireless

S = Proprietary Device
 B = Motorola Blue Chip Program Device
 P = Phoenix Program
 * = First Time in Book
 † = \$200 Minimum Waived

N = Key New Motorola Device
 R = Key "Focus" Motorola Device

1 = Mature, Stable, High-Volume Device
 2 = Moderate-Volume Device
 3 = Low-Volume Device

COMMERCIAL COMPONENTS

Type No.	Grp/Description	Per Unit Sugg.		Factory Order	Incrmnt	
		Resale Price	Price			
MBR7030WT	A REC70A30V SBR247	N	30	14.00	30	†
MBR735	A REC7.5A35V SCHOTT TO220	1	50	1.10	50	†
MBR745	A REC7.5A45V SCHOTT TO220	1	50	1.10	50	†
MBS4991	A PL.BIDIRECT.SWITCH	2	5000	.28	5000	†
MBS4992	A PL.BIDIRECT.SWITCH	2	5000	.88	5000	†
MBS4993	A PL.BIDIRECT.SWITCH	2	5000	.46	5000	†
MCA231	A OPTOISO DARL6-PINDIP	N	50	.98	50	†
MCCS142235DW	L 18-BIT ACTIVE SCSI/TERMATR	N	30	5.10	30	S P
MCCS142235FA	L 18BIT SWITCHBLE SCSI BUS	N	250	5.85	250	S P
MCCS142236DW	L SCSI TERMINATOR18BIT	N	26	3.75	26	
MCCS142237DT	L SCSI TERMINATOR9BIT	N	75	3.17	75	
MCCS142237DTR2	L SCSI TERMINATOR9BIT	2	2500	3.17	2500	
MCCS142237DW	L SCSI TERMINATOR9BIT	N	47	2.87	47	
MCCS142238DW	L 18BIT SCSI TERMINATOR	N	37	4.14	37	
MCF5102PV20B	L 1ST GEN.4U32BIT EM CTRL	N	60	21.28	60	★ B
MCF5102PV25B	L 1ST GEN.4U32BIT EM CTRL	N	60	24.83	60	★ B
MCF5102PV33B	L 32BIT EMBEDDED CONTROLLER	N	60	29.54	60	B
MCF5102PV40B	L 1ST GEN.4U32BIT EM CTRL	N	60	27.49	60	★ B
MCH12140D	V IC MONOPHASE-FREQ DETEC	N	98	22.51	98	S P
MCH12140DR2	V IC MONOPHASE-FREQ DETEC	N	2500	17.48	2500	★ S P
MCK12140D	V MECL PHASE-FREQ DETECTOR	N	98	22.51	98	S P
MCK12140DR2	V MECL PHASE-FREQ DETECTOR	2	2500	22.55	2500	S P
MCK16Y1BGCFT16	J 16-BIT MCU,RAM,32KHZXTAL	N	24	20.90	24	B
MCK16Y1BGCFT16B1	J 16-BIT MCU,RAM,32KHZXTAL	N	120	20.36	120	B
MCLK332ACFC16B1	J 32BIT,MCU,2KRAM,TPU,QSM	N	180	15.47	180	★ B
MCLK332ACPV16B1	J 32BIT,MCU,2KRAM,TPU,QSM	N	300	13.28	300	★ B
MCLK332GFC16B1	J 32BIT,MCU,2KRAM,TPU,QSM	N	180	15.47	180	★ B
MCLK332GCPV16B1	J 32BIT,MCU,2KRAM,TPU,QSM	N	300	13.28	300	★ B
MCM16Y1BGCFT16	J 16-BIT MCU,RAM,4MHZXTAL	N	24	21.14	24	B
MCM16Y1BGCFT16B1	J 16-BIT MCU,RAM,4MHZXTAL	N	120	20.36	120	B
MCM56824AFNC25	N 8KX24 CMOS FSRAM	N	23	30.00	23	★ S
MCM56824AFNC35	N 8KX24 CMOS FSRAM	N	23	30.00	23	★ S
MCM56824AFN20	N 8K X24 CMOS FSRAM	2	23	19.35	23	S
MCM56824AFN20R2	N 8K X24 CMOS FSRAM	N	450	19.35	450	
MCM56824AFN25	N 8K X24 CMOS FSRAM	2	23	18.77	23	S
MCM56824AFN25R2	N 8K X24 CMOS FSRAM	N	450	18.77	450	
MCM56824AFN35	N 8K X24 CMOS FSRAM	2	23	18.39	23	S
MCM56824AFN35R2	N 8K X24 CMOS FSRAM	N	450	18.39	450	
MCM62X308J15-005	N LAST ORDER DATE:09/24/98	N	26	10.56	26	S B
MCM62X308J15-5R2	N LAST ORDER DATE:09/24/98	2	1000	10.72	1000	S B
MCM62X308J17	N LAST ORDER DATE:09/24/98	N	26	8.80	26	S B
MCM6206BAEJ12	N 32KX80.5UM CMOS FSRAM	N	26	2.64	26	
MCM6206BAEJ12R	N 32KX80.5UM CMOS FSRAM	N	1000	2.64	1000	
MCM6206BAEJ15	N 32KX80.5UM CMOS FSRAM	N	26	2.40	26	
MCM6206BAEJ15R	N 32KX80.5UM CMOS FSRAM	N	1000	2.40	1000	

Type No.	Grp/Description	Per Unit Sugg.		Factory Order	Incrmnt	
		Resale Price	Price			
MCM6206BAEJ20	N 32KX80.5UM CMOS FSRAM	N	26	2.40	26	
MCM6206BAEJ20R	N 32KX80.5UM CMOS FSRAM	N	1000	2.40	1000	
MCM6206BAEJ25	N 32KX80.5UM CMOS FSRAM	N	26	2.40	26	
MCM6206BAEJ25R	N 32KX80.5UM CMOS FSRAM	N	1000	2.40	1000	
MCM6206BBEJ12	N 32KX80.45UM CMOS5.0V	N	26	2.64	26	
MCM6206BBEJ12R	N 32KX80.45UM CMOS5.0V	N	1000	2.64	1000	
MCM6206BBEJ15	N 32KX80.45UM CMOS5.0V	N	26	2.40	26	
MCM6206BBEJ15R	N 32KX80.45UM CMOS5.0V	N	1000	2.40	1000	
MCM6206BBEJ20	N 32KX80.45UM CMOS5.0V	N	26	2.40	26	
MCM6206BBEJ25	N 32KX80.45UM CMOS5.0V	N	26	2.40	26	
MCM6206BBEJ25R	N 32KX80.45UM CMOS5.0V	N	1000	2.40	1000	
MCM6226BBEJ15	N 128KX8 CMOS FSRAM WINBOND	N	23	9.60	23	
MCM6226BBEJ15R	N 128KX8 CMOS FSRAM WINBOND	N	1000	9.60	1000	
MCM6226BBEJ20	N 128KX8 CMOS FSRAM WINBOND	N	23	9.60	23	
MCM6226BBEJ20R	N 128KX8 CMOS FSRAM WINBOND	N	1000	9.60	1000	
MCM6226BBEJ25	N 128KX8 CMOS FSRAM WINBOND	N	23	9.60	23	
MCM6226BBEJ25R	N 128KX8 CMOS FSRAM WINBOND	N	1000	9.60	1000	
MCM6226BBXJ15	N 128KX80.5UM CMOS FSRAM	N	23	9.60	23	
MCM6226BBXJ15R	N 128KX80.5UM CMOS FSRAM	2	1000	9.60	1000	
MCM6226BBXJ20	N 128KX80.5UM CMOS FSRAM	N	23	9.60	23	
MCM6226BBXJ20R	N 128KX80.5UM CMOS FSRAM	2	1000	9.60	1000	
MCM6226BBXJ25	N 128KX80.5UM CMOS FSRAM	N	23	9.60	23	
MCM6226BBXJ25R	N 128KX80.5UM CMOS FSRAM	2	1000	9.60	1000	
MCM6226BJ15	N 128K X8 CMOS FSRAM	N	23	9.00	23	
MCM6226BJ15R2	N 128K X8 CMOS FSRAM	2	1000	9.00	1000	
MCM6226BJ20	N 128K X8 CMOS FSRAM	N	23	9.00	23	
MCM6226BJ20R2	N 128K X8 CMOS FSRAM	2	1000	9.00	1000	
MCM6226BJ25	N 128K X8 CMOS FSRAM	N	23	9.00	23	
MCM6226BJ25R2	N 128K X8 CMOS FSRAM	2	1000	9.00	1000	
MCM6226BWJ15R2	N 128K X8 CMOS FSRAM	2	1000	13.50	1000	
MCM6226BWJ20	N LAST ORDER DATE:10/01/98	N	23	13.50	23	
MCM6226BWJ20R2	N 128K X8 CMOS FSRAM	2	1000	13.50	1000	
MCM6226BWJ25	N 128K X8 CMOS FSRAM	N	23	13.50	23	
MCM6226BWJ25R2	N 128K X8 CMOS FSRAM	2	1000	13.50	1000	
MCM6227BJ15	N 1MX1 CMOS FSRAM	N	26	13.50	26	
MCM6227BJ15R2	N 1MX1 CMOS FSRAM	2	1000	13.50	1000	
MCM6227BJ20	N 1MX1 CMOS FSRAM	N	26	13.50	26	
MCM6227BJ20R2	N 1MX1 CMOS FSRAM	2	1000	13.50	1000	
MCM6227BJ25	N 1MX1 CMOS FSRAM	N	26	13.50	26	
MCM6227BJ25R2	N 1MX1 CMOS FSRAM	2	1000	13.50	1000	
MCM6227BWJ15	N 1MX1 CMOS FSRAM	N	26	13.50	26	
MCM6227BWJ15R2	N 1MX1 CMOS FSRAM	2	1000	13.50	1000	
MCM6227BWJ20	N 1MX1 CMOS FSRAM	N	26	13.50	26	
MCM6227BWJ20R2	N 1MX1 CMOS FSRAM	2	1000	13.50	1000	
MCM6227BWJ25	N 1MX1 CMOS FSRAM	N	26	13.50	26	
MCM6227BWJ25R2	N 1MX1 CMOS FSRAM	2	1000	13.50	1000	

A = OSPD/Power
 B = Analog/Logic
 J = Transportation
 L = Consumer
 N = Networking
 V = Wireless

S = Proprietary Device
 B = Motorola Blue Chip Program Device
 P = Phoenix Program
 ★ = First Time in Book
 † \$200 Minimum Waived

N = Key New Motorola Device
 R = Key "Focus" Motorola Device

1 = Mature, Stable, High-Volume Device
 2 = Moderate-Volume Device
 3 = Low-Volume Device

EFFECTIVE DATE: JANUARY 10, 1998

COMMERCIAL COMPONENTS

Type No.	Grp/Description	Per Unit Sugg. Factory		Order	Type No.	Grp/Description	Per Unit Sugg. Factory		Order		
		PC	Qty				Price	Price		PC	Qty
MCM6227BWJ25R2	N 1M X1 CMOS FSRAM	2	1000	13.50	1000	MCM62995AFN25	N 16KX16 LATCHED CMOS FSRAM	2	23	17.55	23
MCM6229BBEJ15	N 256KX4 CMOS FSRAM WINBOND	N	26	9.60	26	MCM62996FN12-005	N 16KX16.8UM CMOS FSRAM	N	23	25.46	23
MCM6229BBEJ15R	N 256KX4 CMOS FSRAM WINBOND	N	1000	9.60	1000	MCM62996FN15	N 16KX16.8UM CMOS FSRAM	N	23	17.55	23
MCM6229BBEJ20	N 256KX4 CMOS FSRAM WINBOND	N	26	9.60	26	MCM62996FN20	N 16KX16.8UM CMOS FSRAM	2	23	17.55	23
MCM6229BBEJ20R	N 256KX4 CMOS FSRAM WINBOND	N	1000	9.60	1000	MCM62996FN25	N 16KX16.8UM CMOS FSRAM	N	23	17.55	23
MCM6229BBEJ25	N 256KX4 CMOS FSRAM WINBOND	N	26	9.60	26	MCM63P631TQ4.5	N 0.35UM CMOS, 3.3V SYNCH.	N	72	18.00	72
MCM6229BBEJ25R	N 256KX4 CMOS FSRAM WINBOND	N	1000	9.60	1000	MCM63P631TQ4.5R	N 0.35UM CMOS, 3.3V SYNCH.	2	700	18.00	700
MCM6229BBXJ15	N 256KX4.05UM CMOS FSRAM	N	26	9.60	26	MCM63P631TQ7	N 0.35UM CMOS, 3.3V SYNCH.	N	72	14.40	72
MCM6229BBXJ15R	N 256KX4.05UM CMOS FSRAM	N	1000	9.60	1000	MCM63P631TQ7R	N 0.35UM CMOS, 3.3V SYNCH.	2	700	14.40	700
MCM6229BBXJ20	N 256KX4.05UM CMOS FSRAM	N	26	9.60	26	MCM63P631TQ8	N 0.35UM CMOS, 3.3V SYNCH.	N	72	14.40	72
MCM6229BBXJ20R	N 256KX4.05UM CMOS FSRAM	N	1000	9.60	1000	MCM63P631TQ8R	N 0.35UM CMOS, 3.3V SYNCH.	2	700	14.40	700
MCM6229BBXJ25	N 256KX4.05UM CMOS FSRAM	N	26	9.60	26	MCM6323AYJ10	N 64KX18.35UM3.3V CMOS	N	16	20.16	16
MCM6229BBXJ25R	N 256KX4.05UM CMOS FSRAM	N	1000	9.60	1000	MCM6323AYJ10R	N 64KX18.35UM3.3V CMOS	N	750	20.16	750
MCM6229BJ15	N 256K X4 CMOS FSRAM	N	26	9.00	26	MCM6323TS12	N 64KX160.55UM CMOS1M	N	135	14.40	135
MCM6229BJ15R2	N 256K X4 CMOS FSRAM	2	1000	9.00	1000	MCM6323TS15	N 64KX160.55UM CMOS1M	N	135	12.96	135
MCM6229BJ20	N 256K X4 CMOS FSRAM	N	26	9.00	26	MCM6323YJ12	N 3.3V64KX16 ASYNCF SRAM	N	16	14.40	16
MCM6229BJ20R2	N 256K X4 CMOS FSRAM	2	1000	9.00	1000	MCM6323YJ12R	N 3.3V64KX16 ASYNCF SRAM	2	750	14.40	750
MCM6229BJ25	N 256K X4 CMOS FSRAM	N	26	9.00	26	MCM6323YJ15	N 3.3V64KX16 ASYNCF SRAM	N	16	12.96	16
MCM6229BJ25R2	N 256K X4 CMOS FSRAM	2	1000	9.00	1000	MCM6323YJ15R	N 3.3V64KX16 ASYNCF SRAM	2	750	12.96	750
MCM6229BWJ15	N 256K X4 CMOS FSRAM	N	26	13.50	26	MCM67A618AFN10	N 64KX18 BIT ASYNCH. FSRAM	N	23	32.40	23 S
MCM6229BWJ15R2	N 256K X4 CMOS FSRAM	2	1000	13.50	1000	MCM67A618AFN10R	N 64KX18 BIT ASYNCH. FSRAM	N	450	32.40	450 S
MCM6229BWJ20	N 256K X4 CMOS FSRAM	N	26	13.50	26	MCM67A618AFN12	N 64KX18 BIT ASYNCH. FSRAM	N	23	30.24	23 S
MCM6229BWJ20R2	N 256K X4 CMOS FSRAM	2	1000	13.50	1000	MCM67A618AFN12R	N 64KX18 BIT ASYNCH. FSRAM	N	450	30.24	450 S
MCM6229BWJ25	N 256K X4 CMOS FSRAM	N	26	13.50	26	MCM67A618AFN15	N 64KX18 BIT ASYNCH. FSRAM	N	23	29.70	23 S
MCM6229BWJ25R2	N 256K X4 CMOS FSRAM	2	1000	13.50	1000	MCM67A618AFN15R	N 64KX18 BIT ASYNCH. FSRAM	N	450	29.70	450 S
MCM6246WJ17	N 512KX8 CMOS FSRAM	N	20	54.60	20	MCM67B618AFN10	N 64KX18 BIT BURSTRAM	N	23	25.65	23
MCM6246WJ17R2	N 512KX8 CMOS FSRAM	2	750	54.60	750	MCM67B618AFN10R2	N 64KX18 BIT BURSTRAM	2	450	25.65	450
MCM6246WJ20	N 512KX8 CMOS FSRAM	N	20	42.00	20	MCM67B618AFN12	N 64KX18 BIT BURSTRAM	N	23	25.65	23
MCM6246WJ20R2	N 512KX8 CMOS FSRAM	2	750	42.00	750	MCM67B618AFN12R2	N 64KX18 BIT BURSTRAM	2	450	25.65	450
MCM6246WJ25	N 512KX8 CMOS FSRAM	N	20	42.00	20	MCM67B618AFN8.5	N 64KX18 BIT BURSTRAM	N	23	27.00	23
MCM6246WJ25R2	N 512KX8 CMOS FSRAM	2	750	42.00	750	MCM67B618AFN8.5R	N 64KX18 BIT BURSTRAM	2	450	27.00	450
MCM6246WJ35	N 512KX8 CMOS FSRAM	N	20	42.00	20	MCM67B618AFN9	N 64KX18 BIT BURSTRAM	N	23	27.00	23
MCM6246WJ35R2	N 512KX8 CMOS FSRAM	2	750	42.00	750	MCM67B618AFN9R2	N 64KX18 BIT BURSTRAM	2	450	27.00	450
MCM6249WJ20	N 1M X4 CMOS FSRAM	N	23	42.00	23	MCM67B618BFN10	N 64KX185VBURSTRAM	N	23	27.00	23
MCM6249WJ20R2	N 1M X4 CMOS FSRAM	2	1000	42.00	1000	MCM67B618BFN10R	N 64KX185VBURSTRAM	N	450	27.00	450
MCM6249WJ25	N 1M X4 CMOS FSRAM	N	23	42.00	23	MCM67B618BFN12	N 64KX185VBURSTRAM	N	23	27.00	23
MCM6249WJ25R2	N 1M X4 CMOS FSRAM	2	1000	42.00	1000	MCM67B618BFN12R	N 64KX185VBURSTRAM	N	450	27.00	450
MCM6249WJ35	N 1M X4 CMOS FSRAM	N	23	42.00	23	MCM67B618BFN9	N 64KX185VBURSTRAM	N	23	27.00	23
MCM6249WJ35R2	N 1M X4 CMOS FSRAM	2	1000	42.00	1000	MCM67B618BFN9R	N 64KX185VBURSTRAM	N	450	27.00	450
MCM62990AFN15	N 16KX16.8UM SYNCH FSRAM	2	23	17.55	23	MCM67C618AFN5	N 64KX18 BIT BURSTRAM	N	23	27.00	23
MCM62990AFN20	N 16KX16.8UM SYNCH FSRAM	N	23	17.55	23	MCM67C618AFN5R2	N 64KX18 BIT BURSTRAM	N	450	27.00	450
MCM62990AFN25	N 16KX16.8UM CMOS FSRAM	N	23	17.55	23	MCM67C618AFN7	N 64KX18 BIT BURSTRAM	N	23	27.00	23
MCM62995AFN12-5	N 16KX16 LATCHED FSRAM	2	23	25.46	23	MCM67C618AFN7R2	N 64KX18 BIT BURSTRAM	2	450	27.00	450
MCM62995AFN15	N 16KX16 LATCHED CMOS FSRAM	2	23	17.55	23	MCM67C618BFN5	N 64KX185VBURSTRAM	N	23	27.00	23
MCM62995AFN20	N 16KX16 LATCHED FSRAM	2	23	17.55	23	MCM67C618BFN5R	N 64KX185VBURSTRAM	N	450	27.00	450

A = OSPD/Power
 B = Analog/Logic
 J = Transportation
 L = Consumer
 N = Networking
 V = Wireless

S = Proprietary Device
 B = Motorola Blue Chip Program Device
 P = Phoenix Program
 * = First Time in Book
 † \$200 Minimum Waived

N = Key New Motorola Device
 R = Key "Focus" Motorola Device

1 = Mature, Stable, High-Volume Device
 2 = Moderate-Volume Device
 3 = Low-Volume Device

COMMERCIAL COMPONENTS

Type No.	Grp/Description	Per Unit Sugg. Factory			
		Resale Price	Price	Order Incrmt	
PC	Qty				
MCM67C618BFN7	N 64KX185VBURSTRAM	N	23	27.00	23
MCM67C618BFN7R	N 64KX185VBURSTRAM	N	450	27.00	450
MCM67H618BFN10	N 64KX185VBURSTRAM	N	23	27.00	23
MCM67H618BFN10R	N 64KX185VBURSTRAM	N	450	27.00	450
MCM67H618BFN12	N 64KX185VBURSTRAM	N	23	27.00	23
MCM67H618BFN12R	N 64KX185VBURSTRAM	N	450	27.00	450
MCM67H618BFN9	N 64KX185VBURSTRAM	N	23	27.00	23
MCM67H618BFN9R	N 64KX185VBURSTRAM	N	450	27.00	450
MCM67M618AFN10	N 64KX18BITBURSTRAMFSRAM	N	23	27.00	1
MCM67M618AFN10R	N 64KX18BITBURSTRAMFSRAM	N	450	27.00	450
MCM67M618AFN12	N 64KX18BITBURSTRAMFSRAM	N	23	27.00	1
MCM67M618AFN12R	N 64KX18BITBURSTRAMFSRAM	N	450	27.00	450
MCM67M618AFN9	N 64KX18BITBURSTRAMFSRAM	N	23	27.00	1
MCM67M618AFN9R	N 64KX18BITBURSTRAMFSRAM	N	450	27.00	450
MCM67M618BFN10	N 64KX185VBURSTRAM	N	23	27.00	23
MCM67M618BFN10R	N 64KX185VBURSTRAM	N	450	27.00	450
MCM67M618BFN12	N 64KX185VBURSTRAM	N	23	27.00	23
MCM67M618BFN12R	N 64KX185VBURSTRAM	N	450	27.00	450
MCM67M618BFN9	N 64KX185VBURSTRAM	N	23	27.00	23
MCM67M618BFN9R	N 64KX185VBURSTRAM	N	450	27.00	450
MCM67Q709AZP10	N 128KX9BITSYNCH.FSRAM	N	102	49.50	102 S
MCM67Q709AZP12	N 128KX9BITSYNCH.FSRAM	N	102	47.03	102 S
MCM67Q709ZP10	N LAST ORDER DATE:03/27/98	N	102	49.50	102 S
MCM67Q909ZP12	N 512KX9SEPARATE I/O SYNC	N	102	117.00	102 S B
MCM67Q909ZP12R	N 512KX9SEPARATE I/O SYNC	2	500	117.00	500 S B
MCM6706BJ10	N 32KX80.5UMBICMOSFSRAM	N	26	10.20	26
MCM6706BJ10R2	N 32KX80.5UMBICMOSFSRAM	N	1000	10.20	1000
MCM6706BJ8	N 32KX80.5UMBICMOSFSRAM	N	26	12.00	26
MCM6706BJ8R2	N 32KX80.5UMBICMOSFSRAM	N	1000	12.00	1000
MCM6706BRJ6	N 32KX80.5UMBICMOSFSRAM	N	23	16.80	23
MCM6706BRJ6R	N 32KX80.5UMBICMOSFSRAM	N	1000	16.80	1000
MCM6706BRJ7	N 32KX80.5UMBICMOSFSRAM	N	23	15.00	23
MCM6706BRJ7R	N 32KX80.5UMBICMOSFSRAM	N	1000	15.00	1000
MCM6706BRJ8	N 32KX80.5UMBICMOSFSRAM	N	23	12.00	23
MCM6706BRJ8R	N 32KX80.5UMBICMOSFSRAM	N	1000	12.00	1000
MCM6706DEJ10	N 32KX80.45UMBICMOS	N	26	10.20	26
MCM6706DEJ10R	N 32KX80.45UMBICMOS	N	1000	10.20	1000
MCM6706DEJ12	N 32KX80.45UMBICMOS	N	26	10.20	26
MCM6706DEJ12R	N 32KX80.45UMBICMOS	N	1000	10.20	1000
MCM6706DEJ8	N 32KX80.45UMBICMOS	N	26	12.00	26
MCM6706DEJ8R	N 32KX80.45UMBICMOS	N	1000	12.00	1000
MCM6706DRJ6	N 32KX80.45UMBICMOS5V	N	23	16.80	23
MCM6706DRJ6R	N 32KX80.45UMBICMOS5V	N	1000	16.80	1000
MCM6706DRJ7	N 32KX80.45UMBICMOS5V	N	23	15.00	23
MCM6706DRJ7R	N 32KX80.45UMBICMOS5V	N	1000	15.00	1000

Type No.	Grp/Description	Per Unit Sugg. Factory			
		Resale Price	Price	Order Incrmt	
PC	Qty				
MCM6706DRJ8	N 32KX80.45UMBICMOS5V	N	23	12.00	23
MCM6706DRJ8R	N 32KX80.45UMBICMOS5V	N	1000	12.00	1000
MCM6726BWJ10	N 128KX8SRAM,0.5UBICMOS	N	23	38.40	23
MCM6726BWJ10R	N 128KX8SRAM,0.5UBICMOS	2	1000	38.40	1000
MCM6726BWJ12	N 128KX8SRAM,0.5UBICMOS	N	23	36.48	23
MCM6726BWJ12R	N 128KX8SRAM,0.5UBICMOS	2	1000	36.48	1000
MCM6726BWJ15	N 128KX8SRAM,0.5UBICMOS	N	23	24.96	23
MCM6726BWJ15R	N 128KX8SRAM,0.5UBICMOS	2	1000	24.96	1000
MCM6726BWJ8	N 128KX8SRAM,0.5UBICMOS	N	23	53.76	23
MCM6726BWJ8R	N 128KX8SRAM,0.5UBICMOS	2	1000	53.76	1000
MCM6726CWJ6	N 128KX8FSRAM,0.5UBICMOS	N	23	73.60	23 S B
MCM6726CWJ6R	N 128KX8FSRAM,0.5UBICMOS	2	1000	73.60	1000 S B
MCM6726CWJ7	N 128KX8FSRAM,0.5UBICMOS	N	23	64.77	23 S B
MCM6726CWJ7R	N 128KX8FSRAM,0.5UBICMOS	2	1000	64.77	1000 S B
MCM6726DWJ10	N 128KX8FSRAM,0.45UM	N	23	38.40	23
MCM6726DWJ10R	N 128KX8FSRAM,0.45UM	N	1000	38.40	1000
MCM6726DWJ12	N 128KX8FSRAM,0.45UM	N	23	36.48	23
MCM6726DWJ12R	N 128KX8FSRAM,0.45UM	N	1000	36.48	1000
MCM6726DWJ15	N 128KX8	N	23	24.96	23
MCM6726DWJ15R	N 128KX8	N	1000	24.96	1000
MCM6726DWJ8	N 128KX8FSRAM,0.45UM	N	23	53.76	23
MCM6726DWJ8R	N 128KX8FSRAM,0.45UM	N	1000	53.76	1000
MCM6729BWJ10	N 256KX4SRAM,0.5UBICMOS	N	23	38.40	23
MCM6729BWJ10R	N 256KX4SRAM,0.5UBICMOS	2	1000	38.40	1000
MCM6729BWJ12	N 256KX4SRAM,0.5UBICMOS	N	23	36.48	23
MCM6729BWJ12R	N 256KX4SRAM,0.5UBICMOS	2	1000	36.48	1000
MCM6729BWJ15	N 256KX4SRAM,0.5UBICMOS	N	23	24.96	23
MCM6729BWJ15R	N 256KX4SRAM,0.5UBICMOS	2	1000	24.96	1000
MCM6729BWJ8	N 256KX4SRAM,0.5UBICMOS	N	23	53.76	23
MCM6729BWJ8R	N 256KX4SRAM,0.5UBICMOS	2	1000	53.76	1000
MCM6729DWJ10	N 256X4FSRAM0.45UMBICMOS	N	23	38.40	23
MCM6729DWJ10R	N 256X4FSRAM0.45UMBICMOS	N	1000	38.40	1000
MCM6729DWJ12	N 256X4FSRAM0.45UMBICMOS	N	23	36.48	23
MCM6729DWJ12R	N 256X4FSRAM0.45UMBICMOS	N	1000	36.48	1000
MCM6729DWJ15	N 256X4FSRAM0.45UMBICMOS	N	23	24.96	23
MCM6729DWJ15R	N 256X4FSRAM0.45UMBICMOS	N	1000	24.96	1000
MCM6729DWJ8	N 256X4FSRAM0.45UMBICMOS	N	23	53.76	23
MCM6729DWJ8R	N 256X4FSRAM0.45UMBICMOS	N	1000	53.76	1000
MCM68A10CP	J LAST ORDER DATE:06/10/98	N	15	4.13	15
MCM68B10P	J LAST ORDER DATE:06/10/98	2	15	3.27	15
MCM69C232TQ20	N 4KX640.41UMBICMOS	N	72	37.80	72 S B
MCM69C432TQ20	N H17C16KX64CAM(0.38UM)	N	72	97.20	72 ★ B
MCM69D536TQ8	N 32KX360.45UMBICMOS	N	40	49.50	40 S B
MCM69D536TQ8R	N 32KX360.45UMBICMOS	N	500	49.50	500 S B
MCM69D618TQ8	N 64KX180.45UMDUALADD.	N	72	49.50	72 S B

A = OSPD/Power
 B = Analog/Logic
 J = Transportation
 L = Consumer
 N = Networking
 V = Wireless

S = Proprietary Device
 B = Motorola Blue Chip Program Device
 P = Phoenix Program
 ★ = First Time in Book
 † \$200 Minimum Waived

N = Key New Motorola Device
 R = Key "Focus" Motorola Device

1 = Mature, Stable, High-Volume Device
 2 = Moderate-Volume Device
 3 = Low-Volume Device

EFFECTIVE DATE: JANUARY 10, 1998

COMMERCIAL COMPONENTS

Type No.	Grp/Description	Per PC	Unit Qty	Sugg. Price	Factory Order	Incrrmt
MCM69D618TQ8R	N 64KX180.45UMDUALADD.	N	700	49.50	700	S B
MCM69F536ATQ10	N 32KX36 BIT FLOW-THROUGH	N	72	27.36	72	
MCM69F536ATQ10R	N 32KX36 BIT FLOW-THROUGH	2	700	27.36	700	
MCM69F536ATQ12	N 32KX36 BIT FLOW-THROUGH	N	72	27.36	72	
MCM69F536ATQ12R	N 32KX36 BIT FLOW-THROUGH	2	700	27.36	700	
MCM69F536ATQ8.5	N 32KX36 BIT FLOW-THROUGH	N	72	28.80	72	
MCM69F536ATQ8.5R	N 32KX36 BIT FLOW-THROUGH	2	700	28.80	700	
MCM69F536ATQ9	N 32KX36 BIT FLOW-THROUGH	N	72	28.80	72	
MCM69F536ATQ9R	N 32KX36 BIT FLOW-THROUGH	2	700	28.80	700	
MCM69F536BTQ10	N 32KX36 BIT FLOW-THROUGH	N	72	27.36	72	
MCM69F536BTQ10R	N 32KX36 BIT FLOW-THROUGH	2	700	27.36	700	
MCM69F536BTQ12	N 32KX36 BIT FLOW-THROUGH	N	72	27.36	72	
MCM69F536BTQ12R	N 32KX36 BIT FLOW-THROUGH	2	700	27.36	700	
MCM69F536BTQ8.5	N 32KX36 BIT FLOW-THROUGH	N	72	28.80	72	
MCM69F536BTQ8.5R	N 32KX36 BIT FLOW-THROUGH	2	700	28.80	700	
MCM69F536BTQ9	N 32KX36 BIT FLOW-THROUGH	N	72	28.80	72	
MCM69F536BTQ9R	N 32KX36 BIT FLOW-THROUGH	2	700	28.80	700	
MCM69F536CTQ10	N 32KX360.38UMBICMOS3.3	N	72	27.36	72	
MCM69F536CTQ10R	N 32KX360.38UMBICMOS3.3	N	700	27.36	700	
MCM69F536CTQ12	N 32KX360.38UMBICMOS3.3	N	72	27.36	72	
MCM69F536CTQ12R	N 32KX360.38UMBICMOS3.3	N	700	27.36	700	
MCM69F536CTQ8.5	N 32KX360.38UMBICMOS3.3	N	72	28.80	72	
MCM69F536CTQ8.5R	N 32KX360.38UMBICMOS3.3	N	700	28.80	700	
MCM69F536CTQ9	N 32KX360.38UMBICMOS3.3	N	72	28.80	72	
MCM69F536CTQ9R	N 32KX360.38UMBICMOS3.3	N	700	28.80	700	
MCM69F618ATQ10	N 64KX18 BIT FLOW-THROUGH	N	72	27.36	72	
MCM69F618ATQ12	N 64KX18 BIT FLOW-THROUGH	N	72	27.36	72	
MCM69F618ATQ8.5	N 64KX18 BIT FLOW-THROUGH	N	72	28.80	72	
MCM69F618ATQ9	N 64KX18 BIT FLOW-THROUGH	N	72	28.80	72	
MCM69F618CTQ10	N 64KX180.38UMBICMOS3.3V	N	72	27.36	72	
MCM69F618CTQ10R	N 64KX180.38UMBICMOS3.3V	N	700	27.36	700	
MCM69F618CTQ12	N 64KX180.38UMBICMOS3.3V	N	72	27.36	72	
MCM69F618CTQ12R	N 64KX180.38UMBICMOS3.3V	N	700	27.36	700	
MCM69F618CTQ8.5	N 64KX180.38UMBICMOS3.3V	N	72	28.80	72	
MCM69F618CTQ8.5R	N 64KX180.38UMBICMOS3.3V	N	700	28.80	700	
MCM69F618CTQ9	N 64KX180.38UMBICMOS3.3V	N	72	28.80	72	
MCM69F618CTQ9R	N 64KX180.38UMBICMOS3.3V	N	700	28.80	700	
MCM69F737TQ7.5	N 128K X364M3.3V	N	72	153.00	72	
MCM69F737TQ7.5R	N 128K X36,4M3.3V	N	700	153.00	700	
MCM69F737TQ8	N 128K X364M3.3V	N	72	131.58	72	
MCM69F737TQ8.5	N 128K X364M3.3V	N	72	114.75	72	
MCM69F737TQ8.5R	N 128K X36,4M3.3V	N	700	114.75	700	
MCM69F737TQ8R	N 128K X36,4M3.3V	N	700	131.58	700	
MCM69F737ZP7.5	N 128K X364M3.3V	N	84	153.00	84	
MCM69F737ZP7.5R	N 128K X36,4M3.3V	2	500	162.00	500	

Type No.	Grp/Description	Per PC	Unit Qty	Sugg. Price	Factory Order	Incrrmt
MCM69F737ZP8	N 128K X364M3.3V	N	84	140.58	84	
MCM69F737ZP8.5	N 128K X364M3.3V	N	84	123.75	84	
MCM69F737ZP8.5R	N 128K X36,4M3.3V	2	500	123.75	500	
MCM69F737ZP8R	N 128K X36,4M3.3V	2	500	140.58	500	
MCM69F819TQ7.5	N 256KX184MFLOW-THROUGH	N	72	153.00	72	
MCM69F819TQ7.5R	N 256KX184MFLOW-THROUGH	N	700	153.00	700	
MCM69F819TQ8	N 256KX184MFLOW-THROUGH	N	72	131.58	72	
MCM69F819TQ8.5	N 256KX184MFLOW-THROUGH	N	72	114.75	72	
MCM69F819TQ8.5R	N 256KX184MFLOW-THROUGH	N	700	114.75	700	
MCM69F819TQ8R	N 256KX184MFLOW-THROUGH	N	700	131.58	700	
MCM69F819ZP7.5	N 256KX184MFLOW-THROUGH	N	84	153.00	84	
MCM69F819ZP7.5R	N 256KX184MFLOW-THROUGH	2	500	162.00	500	
MCM69F819ZP8	N 256KX184MFLOW-THROUGH	N	84	140.58	84	
MCM69F819ZP8.5	N 256KX184MFLOW-THROUGH	N	84	123.75	84	
MCM69F819ZP8.5R	N 256KX184MFLOW-THROUGH	2	500	123.75	500	
MCM69F819ZP8R	N 256KX184MFLOW-THROUGH	2	500	140.58	500	
MCM69P536ATQ4.5	N 32KX36 BIT PIPELINED FSRAM	N	72	46.80	72	
MCM69P536ATQ4.5R	N 32KX36 BIT PIPELINED FSRAM	2	700	46.80	700	
MCM69P536ATQ5	N 32KX36 BIT PIPELINED FSRAM	N	72	37.44	72	
MCM69P536ATQ5R	N 32KX36 BIT PIPELINED FSRAM	2	700	37.44	700	
MCM69P536ATQ6	N 32KX36 BIT PIPELINED FSRAM	N	72	32.76	72	
MCM69P536ATQ6R	N 32KX36 BIT PIPELINED FSRAM	2	700	32.76	700	
MCM69P536ATQ7	N 32KX36 BIT PIPELINED FSRAM	N	72	32.76	72	
MCM69P536ATQ7R	N 32KX36 BIT PIPELINED FSRAM	2	700	32.76	700	
MCM69P536BTQ4.5	N 32KX36 BIT PIPELINED	N	72	46.80	72	
MCM69P536BTQ4.5R	N 32KX36 BIT PIPELINED	2	700	46.80	700	
MCM69P536BTQ5	N 32KX36 BIT PIPELINED	N	72	37.44	72	
MCM69P536BTQ5R	N 32KX36 BIT PIPELINED	2	700	37.44	700	
MCM69P536BTQ6	N 32KX36 BIT PIPELINED	N	72	32.76	72	
MCM69P536BTQ6R	N 32KX36 BIT PIPELINED	2	700	32.76	700	
MCM69P536BTQ7	N 32KX36 BIT PIPELINED	N	72	32.76	72	
MCM69P536BTQ7R	N 32KX36 BIT PIPELINED	2	700	32.76	700	
MCM69P536CTQ4.5	N 32KX36 BIT PIPELINED FSRAM	N	72	46.80	72	
MCM69P536CTQ4.5R	N 32KX36 BIT PIPELINED FSRAM	N	700	46.80	700	
MCM69P536CTQ5	N 32KX36 BIT PIPELINED FSRAM	N	72	46.80	72	
MCM69P536CTQ5R	N 32KX36 BIT PIPELINED FSRAM	N	700	46.80	700	
MCM69P536CTQ6	N 32KX36 BIT PIPELINED FSRAM	N	72	46.80	72	
MCM69P536CTQ6R	N 32KX36 BIT PIPELINED FSRAM	N	700	46.80	700	
MCM69P536CTQ7	N 32KX36 BIT PIPELINED FSRAM	N	72	46.80	72	
MCM69P536CTQ7R	N 32KX36 BIT PIPELINED FSRAM	N	700	46.80	700	
MCM69P618ATQ4.5	N 64KX18 BIT PIPELINE	N	72	46.80	72	
MCM69P618ATQ4.5R	N 64KX18 BIT PIPELINE 3.3V	2	700	46.80	700	
MCM69P618ATQ5	N 64KX18 BIT PIPELINE	N	72	37.44	72	
MCM69P618ATQ5R	N 64KX18 BIT PIPELINE	2	700	37.44	700	
MCM69P618ATQ6	N 64KX18 BIT PIPELINE	N	72	32.76	72	

A = OSPD/Power
 B = Analog/Logic
 J = Transportation
 L = Consumer
 N = Networking
 V = Wireless

S = Proprietary Device
 B = Motorola Blue Chip Program Device
 P = Phoenix Program
 * = First Time in Book
 † = \$200 Minimum Waived

N = Key New Motorola Device
 R = Key "Focus" Motorola Device

1 = Mature, Stable, High-Volume Device
 2 = Moderate-Volume Device
 3 = Low-Volume Device

COMMERCIAL COMPONENTS

Type No.	Grp/Description	Per Unit Sugg. Factory			
		Resale Price	Price	Order	
PC	Qty	Price	Incrmnt		
MCM69P618ATQ6R	N 64KX18BIT PIPELINE	2	700	32.76	700
MCM69P618ATQ7	N 64KX18BIT PIPELINE	N	72	32.76	72
MCM69P618ATQ7R	N 64KX18BIT PIPELINE	2	700	32.76	700
MCM69P618CTQ4.5	N 64KX18BIT PIPELINE	N	72	46.80	72
MCM69P618CTQ4.5R	N 64KX18BIT PIPELINE	N	700	46.80	700
MCM69P618CTQ5	N 64KX18BIT PIPELINE	N	72	46.80	72
MCM69P618CTQ5R	N 64KX18BIT PIPELINE	N	700	46.80	700
MCM69P618CTQ6	N 64KX18BIT PIPELINE	N	72	46.80	72
MCM69P618CTQ6R	N 64KX18BIT PIPELINE	N	700	46.80	700
MCM69P618CTQ7	N 64KX18BIT PIPELINE	N	72	46.80	72
MCM69P618CTQ7R	N 64KX18BIT PIPELINE	N	700	46.80	700
MCM69P737TQ4	N 128KX364M3.3V PIPELINED	N	72	122.40	72
MCM69P737TQ4R	N 128KX364M3.3V PIPELINED	N	700	122.40	700
MCM69P737ZP3.5	N 128KX364M3.3V PIPELINED	N	84	153.00	84
MCM69P737ZP3.5R	N 128KX364M3.3V PIPELINED	2	500	153.00	500
MCM69P737ZP3.8	N 128KX364M3.3V PIPELINED	N	84	153.00	84
MCM69P737ZP3.8R	N 128KX364M3.3V PIPELINED	2	500	153.00	500
MCM69P737ZP4	N 128KX364M3.3V PIPELINED	N	84	122.40	84
MCM69P737ZP4R	N 128KX364M3.3V PIPELINED	2	500	122.40	500
MCM69P819TQ4	N 256KX184M3.3V PIPELINED	N	72	122.40	72
MCM69P819TQ4R	N 256KX184M3.3V PIPELINED	N	700	122.40	700
MCM69P819ZP3.5	N 256KX184M3.3V PIPELINED	N	84	153.00	84
MCM69P819ZP3.5R	N 256KX184M3.3V PIPELINED	2	500	153.00	500
MCM69P819ZP3.8	N 256KX184M3.3V PIPELINED	N	84	145.35	84
MCM69P819ZP3.8R	N 256KX184M3.3V PIPELINED	2	500	145.35	500
MCM69P819ZP4	N 256KX184M3.3V PIPELINED	N	84	137.70	84
MCM69P819ZP4R	N 256KX184M3.3V PIPELINED	2	500	137.70	500
MCM69T618TQ5	N 64KX18 PIPELINE CACHE	N	72	50.40	72 S
MCM69T618TQ5R	N 64KX18 PIPELINE CACHE	2	700	50.40	700 S
MCM69T618ZP5	N 64KX18 PIPELINE CACHE TAG	N	84	44.80	84 S
MCM69T618ZP5R	N 64KX18 PIPELINE CACHE TAG	2	500	44.80	500 S
MCM6926AWJ10	N 3.3V128KX8MOS11 REV.	N	23	29.25	23
MCM6926AWJ10R	N 3.3V128KX8MOS11 REV.	N	1000	29.25	1000
MCM6926AWJ12	N 3.3V128KX8MOS11 REV.	N	23	27.00	23
MCM6926AWJ12R	N 3.3V128KX8MOS11 REV.	N	1000	27.00	1000
MCM6926AWJ15	N 3.3V128KX8MOS11 REV.	N	23	27.00	23
MCM6926AWJ15R	N 3.3V128KX8MOS11 REV.	N	1000	27.00	1000
MCM6926AWJ8	N 3.3V128KX8MOS11 REV.	N	23	45.00	23
MCM6926AWJ8R	N 3.3V128KX8MOS11 REV.	N	1000	45.00	1000
MCM6926WJ10	N 128KX8FSRAM3.3V0.5UM	N	23	29.25	23
MCM6926WJ10R	N 128KX8FSRAM3.3V0.5UM	2	1000	29.25	1000
MCM6926WJ12	N 128KX8FSRAM3.3V0.5UM	N	23	27.00	23
MCM6926WJ12R	N 128KX8FSRAM3.3V0.5UM	2	1000	27.00	1000
MCM6926WJ8	N 128KX8FSRAM3.3V0.5UM	N	23	45.00	23
MCM6926WJ8R	N 128KX8FSRAM3.3V0.5UM	2	1000	45.00	1000

Type No.	Grp/Description	Per Unit Sugg. Factory			
		Resale Price	Price	Order	
PC	Qty	Price	Incrmnt		
MCM6929AWJ10	N 3.3V256KX4MOS11 REV.	N	23	29.25	23
MCM6929AWJ10R	N 3.3V256KX4MOS11 REV.	N	1000	29.25	1000
MCM6929AWJ12	N 3.3V256KX4MOS11 REV.	N	23	27.00	23
MCM6929AWJ12R	N 3.3V256KX4MOS11 REV.	N	1000	27.00	1000
MCM6929AWJ15	N 3.3V256KX4MOS11 REV.	N	23	27.00	23
MCM6929AWJ15R	N 3.3V256KX4MOS11 REV.	N	1000	27.00	1000
MCM6929AWJ8	N 3.3V256KX4MOS11 REV.	N	23	45.00	23
MCM6929AWJ8R	N 3.3V256KX4MOS11 REV.	N	1000	45.00	1000
MCM6929WJ10	N 256KX4FSRAM3.3V0.5UM	N	23	29.25	23
MCM6929WJ10R	N 256KX4FSRAM3.3V0.5UM	2	1000	29.25	1000
MCM6929WJ12	N 256KX4FSRAM3.3V0.5UM	N	23	27.00	23
MCM6929WJ12R	N 256KX4FSRAM3.3V0.5UM	2	1000	27.00	1000
MCM6929WJ8	N 256KX4FSRAM3.3V0.5UM	N	23	45.00	23
MCM6929WJ8R	N 256KX4FSRAM3.3V0.5UM	2	1000	45.00	1000
MCM6946TS10	N 512KX80.38UM3.3VSRAM	N	135	162.00	135
MCM6946TS12	N 512KX80.38UM3.3VSRAM	N	135	121.50	135
MCM6946TS15	N 512KX80.38UM3.3VSRAM	N	135	121.50	135
MCM6946TS8	N 512KX80.38UM3.3VSRAM	N	135	324.00	135
MCM6946YJ10	N 512KX80.38UM3.3VSRAM	N	20	162.00	20
MCM6946YJ10R	N 512KX80.38UM3.3VSRAM	N	750	162.00	750
MCM6946YJ12	N 512KX80.38UM3.3VSRAM	N	20	121.50	20
MCM6946YJ12R	N 512KX80.38UM3.3VSRAM	N	750	121.50	750
MCM6946YJ15	N 512KX80.38UM3.3VSRAM	N	20	121.50	20
MCM6946YJ15R	N 512KX80.38UM3.3VSRAM	N	750	121.50	750
MCM6946YJ8	N 512KX80.38UM3.3VSRAM	N	20	324.00	20
MCM6946YJ8R	N 512KX80.38UM3.3VSRAM	N	750	324.00	750
MCM6949TS10	N 1MX40.38UM3.3VSRAM	N	135	162.00	135
MCM6949TS12	N 1MX40.38UM3.3VSRAM	N	135	121.50	135
MCM6949TS15	N 1MX40.38UM3.3VSRAM	N	135	121.50	135
MCM6949TS8	N 1MX40.38UM3.3VSRAM	N	135	324.00	135
MCM6949YJ10	N 1MX40.38UM3.3VSRAM	N	16	162.00	23
MCM6949YJ10R	N 1MX40.38UM3.3VSRAM	N	1000	162.00	1000
MCM6949YJ12	N 1MX40.38UM3.3VSRAM	N	16	121.50	23
MCM6949YJ12R	N 1MX40.38UM3.3VSRAM	N	1000	121.50	1000
MCM6949YJ15	N 1MX40.38UM3.3VSRAM	N	16	121.50	23
MCM6949YJ15R	N 1MX40.38UM3.3VSRAM	N	1000	121.50	1000
MCM6949YJ8	N 1MX40.38UM3.3VSRAM	N	16	324.00	23
MCM6949YJ8R	N 1MX40.38UM3.3VSRAM	N	1000	324.00	1000
MCR08BT1	A SOT223 S C R	2	1000	.62	1000 †
MCR08MT1	A SOT223 S C R	2	1000	.66	1000 †
MCR100-003	A THYRSCR.8A100VTO92	2	5000	.26	5000 †
MCR100-006	A THYRSCR.8A400VTO92	1	5000	.32	5000 †
MCR100-008	A THYRSCR.8A600VTO92	1	5000	.36	5000 †
MCR106-006	A SCR4A400V CASE77	1	500	.44	500 †
MCR106-008	A SCR4A600V CASE77	2	500	.48	500 †

A = OSPD/Power
 B = Analog/Logic
 J = Transportation
 L = Consumer
 N = Networking
 V = Wireless

S = Proprietary Device
 B = Motorola Blue Chip Program Device
 P = Phoenix Program
 ★ = First Time in Book
 † \$200 Minimum Waived

N = Key New Motorola Device
 R = Key "Focus" Motorola Device

1 = Mature, Stable, High-Volume Device
 2 = Moderate-Volume Device
 3 = Low-Volume Device

COMMERCIAL COMPONENTS

Type No.	Grp/Description	Per Unit Sugg. Factory				Type No.	Grp/Description	Per Unit Sugg. Factory					
		PC	Qty	Price	Order			PC	Qty	Price	Order		
MCR12D	A 12AMPS400VTO220 SCR	N	50	.88	50	†	MCT1413P	B LIN PERIP DRVR ARRAY	1	25	.61	500	†
MCR12LD	A 12AMP SCR TO220400V	N	50	.88	50	†	MCT1458CD	B DUAL OP AMP	N	98	.48	98	†
MCR12LM	A 12AMP SCR TO220600V	N	50	.90	50	†	MCT1458CP1	B DUAL OP AMP	N	50	.42	1000	†
MCR12LN	A 12AMP SCR TO220800V	N	50	.94	50	†	MCT1458D	B DUAL OP AMP	N	98	.52	98	†
MCR12M	A 12AMPS600VTO220 SCR	N	50	.90	50	†	MCT1458DR2	B DUAL OP AMP	2	2500	.57	2500	†
MCR12N	A 12AMPS800VTO220 SCR	N	50	.94	50	†	MCT1458P1	B DUAL OP AMP	N	50	.45	1000	†
MCR16N	A 16AMPS TO220 SCR800V	N	50	1.16	50	†	MCT2	A OPTOISO XTR6-PIN DIP	2	50	.50	50	†
MCR218-002	A SCR8A50VTO220	2	500	.76	500	†	MCT2E	A OPTOISOLATOR6-PIN DIP	2	50	.50	50	†
MCR218-004	A SCR8A200V TO220	3	500	1.44	500	†	MCT271	A OPTOISO XTR6-PIN DIP	3	50	1.79	50	†
MCR218-006	A SCR8A400V TO220	3	500	1.48	500	†	MCT272	A OPTOISO XTR6-PIN DIP	3	50	1.79	50	†
MCR218-10FP	A SCR8A800V ISO TO220	3	500	2.79	500	†	MCT275	A OPTOISO XTR6PIN-DIP	N	50	1.04	50	†
MCR218-6FP	A SCR8A400V ISO TO220	3	500	2.42	500	†	MCT4558CD	B DUAL WIDEBAND OP AMP	N	98	.70	98	†
MCR218-8FP	A SCR8A600V ISO TO220	3	500	2.69	500	†	MCT4558CP1	B DUAL WIDEBAND OP AMP	N	50	.61	1000	†
MCR22-006	A SCR1.5A400V TO92	1	5000	.36	5000	†	MCT4558VD	B DUAL WIDEBAND OP AMP	N	98	.83	98	†
MCR22-008	A SCR1.5A600V TO92	2	5000	.40	5000	†	MC10ELT20D	B TTL TO DIFF PECL TRANSLTR	N	98	6.78	98	S P
MCR22-6RLRA	A SCR1.5A400V TO92	2	2000	.36	2000	†	MC10ELT21D	B DIFF PECL TO TTL TRANSLTR	N	98	6.78	98	S P
MCR225-10FP	A SCR25A800V ISO TO220	3	500	3.94	500	†	MC10ELT22D	B DUAL TTL TO DIFF PECL TRN	1	98	6.78	98	S P
MCR225-2FP	A SCR25A50V ISO TO220	3	500	2.69	500	†	MC10ELT22DR2	B DUAL TTL TO DIFF PECL TRN	2	2500	6.78	2500	S P
MCR225-8FP	A SCR25A600V ISO TO220	1	500	1.80	500	†	MC10ELT24D	B TTL TO DIFF ECL TRANS	N	98	6.78	98	S P
MCR25D	A 25AMPS SCR TO220	N	50	1.38	50	†	MC10ELT25D	B DIFFERENTIAL ECL TO TTL TRN	1	98	6.78	98	S P
MCR25M	A 25AMPS SCR TO220	N	50	1.40	50	†	MC10ELT25DR2	B DIFFERENTIAL ECL TO TTL TRN	N	2500	6.78	2500	S P
MCR25N	A 25AMPS SCR TO220	N	50	1.42	50	†	MC10ELT28D	B TTL TO DIFF PECL TRNS DIF	N	98	6.78	98	S P
MCR264-004	A SCR40A200V TO220	1	500	2.10	500	†	MC10ELT28DR2	B TTL TO DIFF PECL TRNS DIF	2	2500	6.78	2500	S P
MCR264-006	A SCR40A400V TO220	2	500	2.14	500	†	MC10EL01D	B 4-INPUT OR/NOR	1	98	8.33	98	
MCR264-008	A SCR40A600V TO220	2	500	2.18	500	†	MC10EL01DR2	B 4-INPUT OR/NOR	2	2500	8.33	2500	
MCR265-004	A SCR55A200V TO220	1	500	2.50	500	†	MC10EL04D	B 2-INPUT AND/NAND	1	98	8.33	98	
MCR265-006	A SCR55A400V TO220	2	500	2.56	500	†	MC10EL04DR2	B 2-INPUT AND/NAND	2	2500	8.33	2500	
MCR265-008	A SCR55A600V TO220	1	500	2.64	500	†	MC10EL05D	B 2-INPUT DIFF AND/NAND	1	98	8.33	98	
MCR265-010	A SCR55A800V TO220	2	500	2.96	500	†	MC10EL05DR2	B 2-INPUT DIFF AND/NAND	2	2500	8.33	2500	
MCR310-010	A SCR10A800V TO220	3	500	1.79	500	†	MC10EL07D	B 2-INPUT XOR/XNOR	2	98	8.33	98	
MCR506-002	A SCR6A50V CASE77	3	500	1.05	500	†	MC10EL07DR2	B 2-INPUT XOR/XNOR	2	2500	8.33	2500	
MCR68-002	A SCR12A50V TO220	2	500	1.20	500	†	MC10EL11D	B 1:2 DIFFERENTIAL CLCK DVR	1	98	8.33	98	
MCR69-002	A SCR25A50V TO220	2	500	1.44	500	†	MC10EL11DR2	B 1:2 DIFFERENTIAL CLCK DVR	2	2500	8.33	2500	
MCR703AT4	A SCR4A100V D-PAK T/R	2	2500	.64	2500	†	MC10EL12D	B DRIVER	2	98	8.33	98	
MCR704AT4	A SCR4A200V D-PAK T/R	2	2500	.66	2500	†	MC10EL12DR2	B DRIVER	2	2500	8.33	2500	
MCR708A	A SCR4A600V D-PAK	3	75	1.36	75	†	MC10EL15D	B 1:4 CLOCK DISTRBUTON CHIP	N	48	8.33	48	
MCR708AT4	A SCR4A600V D-PAK T/R	2	2500	.72	2500	†	MC10EL15DR2	B 1:4 CLOCK DISTRBUTON CHIP	2	2500	8.33	2500	
MCR72-003	A SCR8A100V TO220	3	500	1.60	500	†	MC10EL16D	B DIFFERENTIAL RECEIVER	1	98	8.33	98	
MCR72-006	A SCR8A400V TO220	2	500	.88	500	†	MC10EL16DR2	B DIFFERENTIAL RECEIVER	2	2500	8.33	2500	
MCR72-008	A SCR8A600V TO220	2	500	.92	500	†	MC10EL31D	B D FLIP FLOP SET&RESET	1	98	8.33	98	
MCR8N	A 8AMPS TO220 SCR800V	N	50	.80	50	†	MC10EL31DR2	B D FLIP FLOP SET&RESET	2	2500	8.33	2500	
MCR8SD	A 8AMP SENSITIVE SCR TO220	N	50	.84	50	†	MC10EL32D	B +2 DIVIDER DIFRNTAL INPUT	1	98	8.33	98	
MCR8SM	A 8AMP SENSITIVE SCR TO220	N	50	.88	50	†	MC10EL32DR2	B +2 DIVIDER DIFRNTAL INPUT	2	2500	8.33	2500	
MCR8SN	A 8AMP SENSITIVE SCR TO220	N	50	.96	50	†	MC10EL33D	B +4 DIVIDER DIFRNTAL INPUT	1	98	8.33	98	
MCT1413BP	B LIN PERIP DRVR ARRAY	N	25	.73	500	†	MC10EL33DR2	B +4 DIVIDER DIFRNTAL INPUT	2	2500	8.33	2500	

A = OSPD/Power
B = Analog/Logic
J = Transportation
L = Consumer
N = Networking
V = Wireless

S = Proprietary Device
B = Motorola Blue Chip Program Device
P = Phoenix Program
★ = First Time in Book
† = \$200 Minimum Waived

N = Key New Motorola Device
R = Key "Focus" Motorola Device

1 = Mature, Stable, High-Volume Device
2 = Moderate-Volume Device
3 = Low-Volume Device

COMMERCIAL COMPONENTS

Type No.	Grp/Description	Per Unit Sugg. Factory			
		Resale Price	Price	Order	
PC	Qty	Price	Incrrmnt		
MC10EL34D	B DIVDE BY2,4,8CLOCK GEN	N	48	8.33	48
MC10EL35D	B J-K FLIP FLOP	2	98	8.33	98
MC10EL35DR2	B J-K FLIP FLOP	2	2500	8.33	2500
MC10EL51D	B DIFF CLOCK D FLIP FLOP	2	98	8.33	98
MC10EL51DR2	B DIFF CLOCK D FLIP FLOP	2	2500	8.33	2500
MC10EL52D	B DIFF DATA/D FLIP FLOP	2	98	8.33	98
MC10EL52DR2	B DIFF DATA/D FLIP FLOP	2	2500	8.33	2500
MC10EL57D	B 4:1 DIFFERENTIAL MULTIPLX	1	48	8.33	48
MC10EL57DR2	B 4:1 DIFFERENTIAL MULTIPLX	2	2500	8.33	2500
MC10EL58D	B 2:1 MULTIPLLEXER	1	98	8.33	98
MC10EL58DR2	B 2:1 MULTIPLLEXER	2	2500	8.33	2500
MC10EL89D	B COAXIAL CABLE DRIVER	1	98	8.33	98
MC10EL89DR2	B COAXIAL CABLE DRIVER	2	2500	8.33	2500
MC10E016FN	B 8-BIT SYNCH BIN UP COUNT	1	37	22.50	37
MC10E101FN	B 4-BIT INPUT OR/NOR GATE	1	37	18.33	37
MC10E101FNR2	B 4-BIT INPUT OR/NOR GATE	2	500	18.33	500
MC10E104FN	B 5-BIT2-INAND/NAND GATE	1	37	18.33	37
MC10E104FNR2	B 5-BIT2-INAND/NAND GATE	2	500	18.33	500
MC10E107FN	B 5-BIT2-INXOR/NOR GATE	N	37	18.33	37
MC10E107FNR2	B 5-BIT2-INXOR/NOR GATE	2	500	18.33	500
MC10E111FN	B 1:9 DIFFERENTIAL CLOCK DR	1	37	21.88	37
MC10E111FNR2	B 1:9 DIFFERENTIAL CLOCK DR	2	500	21.97	500
MC10E112FN	B 4-BIT DRVR COMMON ENABLE	N	37	18.33	37
MC10E116FN	B 5-BIT DIFF LINE RECEIVER	1	37	18.33	37
MC10E116FNR2	B 5-BIT DIFF LINE RECEIVER	2	500	18.33	500
MC10E122FN	B 9-BIT BUFFER	2	37	18.33	37
MC10E122FNR2	B 9-BIT BUFFER	2	500	18.33	500
MC10E131FN	B 4-BIT D FLIP/FLOP	1	37	21.92	37
MC10E131FNR2	B 4-BIT D FLIP/FLOP	2	500	21.92	500
MC10E136FN	B 6-BIT UNIV COUNTER	2	37	29.17	37
MC10E137FN	B 8-BIT RIPPLE COUNTER	2	37	29.17	37
MC10E137FNR2	B 8-BIT RIPPLE COUNTER	2	500	29.17	500
MC10E141FN	B 8-BIT SHIFT REGISTER	1	37	29.17	37
MC10E141FNR2	B 8-BIT SHIFT REGISTER	2	500	29.17	500
MC10E142FN	B 9-BIT SHIFT REGISTER	2	37	29.17	37
MC10E142FNR2	B 9-BIT SHIFT REGISTER	2	500	29.17	500
MC10E143FN	B 9-BIT HOLD REGISTER	1	37	29.17	37
MC10E143FNR2	B 9-BIT HOLD REGISTER	2	500	29.17	500
MC10E151FN	B 6-BIT D REGISTER	2	37	25.67	37
MC10E154FN	B 5-BIT2:1 MUX-LATCH	2	37	25.67	37
MC10E155FN	B 6-BIT2:1 MUX-LATCH	2	37	25.67	37
MC10E155FNR2	B 6-BIT2:1 MUX-LATCH	N	500	25.67	500
MC10E156FN	B 3-BIT4:1 MUX-LATCH	2	37	25.67	37
MC10E156FNR2	B 3-BIT4:1 MUX-LATCH	N	500	25.67	500
MC10E157FN	B 4-BIT2:1 MULTIPLEXER	2	37	21.92	37

Type No.	Grp/Description	Per Unit Sugg. Factory			
		Resale Price	Price	Order	
PC	Qty	Price	Incrrmnt		
MC10E157FNR2	B 4-BIT2:1 MULTIPLEXER	N	500	21.92	500
MC10E158FN	B 5-BIT2:1 MULTIPLEXER	N	37	21.92	37
MC10E158FNR2	B 5-BIT2:1 MULTIPLEXER	2	500	21.92	500
MC10E163FN	B 2-BIT8:1 MULTIPLEXER	2	37	21.92	37
MC10E163FNR2	B 2-BIT8:1 MULTIPLEXER	2	500	21.92	500
MC10E164FN	B 16:1 MULTIPLEXER	2	37	21.92	37
MC10E164FNR2	B 16:1 MULTIPLEXER	N	500	21.92	500
MC10E1651FN	B DUAL HIGH PERF COMPARTOR	2	46	43.92	46 S P
MC10E1652FN	B DUAL HIGH PREFORM COMPRAT	2	46	43.92	46 S P
MC10E166FN	B 9-BIT MAGNITUDE COMP	N	37	25.67	37
MC10E167FN	B 6-BIT2:1 MUX-REGISTER	2	37	25.67	37
MC10E171FN	B 3-BIT4:1 MULTIPLEXER	2	37	21.92	37
MC10E171FNR2	B 3-BIT4:1 MULTIPLEXER	2	500	21.92	500
MC10E175FN	B 9-BIT LATCH WITH PARITY	2	37	25.67	37
MC10E195FN	B PROGRAMMABLE DELAY CHIP	1	37	29.17	37
MC10E196FN	B PRGRMBL DELAY CHP10H COM	2	37	29.17	37
MC10E197FN	B HARD DISK DATA SEPARATOR	2	37	29.17	37
MC10E211FN	B 6BIT DIFRNTL CLK DRVR	N	37	21.88	37
MC10E211FNR2	B 6-BIT DIFRNTAL CLK DRIVER	N	500	21.97	500
MC10E212FN	B 3BIT SCAN REGIST ADD/DRIV	N	37	18.33	37
MC10E337FN	B 3-BIT SCAN REGIST BUS TRA	N	37	21.92	37
MC10E337FNR2	B 3-BIT SCAN REGIST BUS TRA	2	500	21.92	500
MC10E404FN	B 4-B DIFFERENTIAL AND/NAND	2	37	18.33	37
MC10E411FN	B 1:9 DIFF RAMBUS CLK DR.	N	37	21.88	37
MC10E411FNR2	B 1:9 DIFF RAMBUS CLK DR.	2	500	21.97	500
MC10E416FN	B QUINT DIFF LINE RECVR	N	37	18.33	37
MC10E431FN	B 3-BIT DIFFERENT FLIP/FLOP	N	37	21.92	37
MC10E445FN	B 4-BITSRIAL/PARELLEL CONV	N	37	29.17	37
MC10E445FNR2	B 4-BIT SRIAL/PARELLEL CONV	2	500	29.17	500
MC10E446FN	B 4-BIT PARALLEL/SRAL CONVR	N	37	29.17	37
MC10E451FN	B 6-BIT DREGULATOR	2	37	25.67	37
MC10E452FN	B 5-BIT DIFFERENTIAL REGIST	2	37	25.67	37
MC10E452FNR2	B 5-BIT DIFFERENTIAL REGIST	2	500	25.67	500
MC10E457FN	B DIFFERENTIAL2:1 MULTIPLX	1	37	21.92	37
MC10H016FN	B MECL4-BIT BINARY COUNTER	1	46	17.53	46 S P
MC10H016L	B MECL4-BIT BINARY COUNTER	2	25	16.90	25 S P
MC10H016P	B MECL4-BIT BINARY COUNTER	1	25	13.00	25 S P †
MC10H100L	B MECL QUAD NOR GATE	3	25	3.82	25 S P
MC10H101FN	B MECL QUAD OR/NOR GATE	1	46	2.12	46 S P
MC10H101FNR2	B MECL QUAD OR/NOR	2	500	2.02	500 S P
MC10H101L	B MECL QUAD OR/NOR GATE	3	25	4.15	25 S P
MC10H101P	B MECL QUAD OR/NOR GATE	1	25	1.27	25 S P †
MC10H102FN	B MECL QUAD2I/P NOR GATE	1	46	2.12	46 S P
MC10H102FNR2	B MECL QUAD2I/P NOR GATE	2	500	1.27	500 S P
MC10H102L	B MECL QUAD2I/P NOR GATE	3	25	3.33	25 S P

A = OSPD/Power
 B = Analog/Logic
 J = Transportation
 L = Consumer
 N = Networking
 V = Wireless

S = Proprietary Device
 B = Motorola Blue Chip Program Device
 P = Phoenix Program
 * = First Time in Book
 † \$200 Minimum Waived

N = Key New Motorola Device
 R = Key "Focus" Motorola Device

1 = Mature, Stable, High-Volume Device
 2 = Moderate-Volume Device
 3 = Low-Volume Device

COMMERCIAL COMPONENTS

Type No.	Grp/Description	Per Unit Sugg. Factory				PC	Qty	Price	Order	Incrrmnt	Type No.	Grp/Description	Per Unit Sugg. Factory				PC	Qty	Price	Order	Incrrmnt
		Resale	Price	Order	Incrrmnt								Resale	Price	Order	Incrrmnt					
MC10H102P	B MECLQUAD2I/P NOR GATE	2	25	1.27	25	S	P	†		MC10H125P	B MECLQDECLTOTTLXLTR	1	25	2.92	25	S	P	†			
MC10H103FN	B MECLQUAD2I/P OR GATE	2	46	2.12	46	S	P			MC10H130L	B MECLDUAL LATCH	3	25	9.45	25	S	P				
MC10H103L	B MECLQUAD2I/P OR GATE	3	25	3.64	25	S	P			MC10H131FN	B MECLDLTYPE DMSFF	1	46	4.35	46	S	P				
MC10H103P	B MECLQUAD2I/P OR GATE	2	25	1.27	25	S	P	†		MC10H131FNR2	B MECLDLTYPE DMSFF,P/C	2	500	2.59	500	S	P				
MC10H104FN	B MECLQUAD2I/P AND GATE	2	46	2.12	46	S	P			MC10H131L	B MECLDLTYPE DMSFF	2	25	4.45	25	S	P				
MC10H104FNR2	B MECLQUAD2I/P GATE	2	500	1.26	500	S	P			MC10H131P	B MECLDLTYPE DMSFF	1	25	2.53	25	S	P	†			
MC10H104L	B MECLQUAD2I/P AND GATE	3	25	4.15	25	S	P			MC10H135FN	B MECLDUAL J-KMSFF	2	46	5.08	46	S	P				
MC10H104P	B MECLQUAD2I/P AND GATE	2	25	1.27	25	S	P	†		MC10H135FNR2	B MECLDUAL J-KMSFF	2	500	3.04	500	S	P				
MC10H105FN	B MECLTRPL2-3-2I/POR/NOR	2	46	2.12	46	S	P			MC10H135L	B MECLDUAL J-KMSFF	3	25	11.88	25	S	P				
MC10H105FNR2	B MECLTRPL2-3-2I/POR/NOR	2	500	1.27	500	S	P			MC10H135P	B MECLDUAL J-KMSFF	2	25	3.98	25	S	P	†			
MC10H105L	B MECLTRPL2-3-2I/POR/NOR	3	25	4.15	25	S	P			MC10H136FN	B MECLUNIVSLHEXDECMLCNTR	1	46	17.42	46	S	P				
MC10H105P	B MECLTRPL2-3-2I/POR/NOR	2	25	1.27	25	S	P	†		MC10H136FNR2	B MECLUNIVSLHEXDECMLCNTR	2	500	10.42	500	S	P				
MC10H106L	B MECLTRPL4-3-3I/PNOR	3	25	3.82	25	S	P			MC10H136L	B MECLUNIVSLHEXDECMLCNTR	2	25	21.12	25	S	P				
MC10H106P	B MECLTRPL4-3-3I/PNOR	N	25	1.20	25	S		†		MC10H136P	B MECLUNIVSLHEXDECMLCNTR	1	25	13.00	25	S	P	†			
MC10H107FN	B MECLTRPLEXCOR/NOR	2	46	2.12	46	S	P			MC10H141FN	B MECL4-BIT UNIVERSALSR	2	46	6.97	46	S	P				
MC10H107FNR2	B MECLTRPLEXCOR/NOR	2	500	1.26	500	S	P			MC10H141L	B MECL4-BIT UNIVERSALSR	2	25	6.53	25	S	P				
MC10H107L	B MECLTRPLEXCOR/NOR	3	25	4.15	25	S	P			MC10H141P	B MECL4-BIT UNIVERSALSR	2	25	3.98	25	S	P	†			
MC10H107P	B MECLTRPLEXCOR/NOR	2	25	1.27	25	S	P	†		MC10H145FN	B MECL16X4REGISTER FILE	N	46	15.27	46	S	P				
MC10H109FN	B MECLDL4-5I/POR/NOR	2	46	2.12	46	S	P			MC10H145L	B MECL16X4REGISTER FILE	3	25	21.65	25	S	P				
MC10H109L	B MECLDL4-5I/POR/NOR	3	25	4.15	25	S	P			MC10H145P	B MECL16X4REGISTER FILE	2	25	10.18	25	S	P	†			
MC10H109P	B MECLDL4-5I/POR/NOR	2	25	1.27	25	S	P	†		MC10H158FN	B MECLQD2I/P MULTIPLEXER	1	46	3.68	46	S	P				
MC10H113FN	B MECLQDEXCLUSIVE OR GATE	2	46	2.12	46	S	P			MC10H158FNR2	B MECLQD2I/P MULTIPLEXER	2	500	2.18	500	S	P				
MC10H113L	B MECLQDEXCLUSIVE OR GATE	3	25	4.15	25	S	P			MC10H158L	B MECLQD2I/P MULTIPLEXER	3	25	8.27	25	S	P				
MC10H113P	B MECLQDEXCLUSIVE OR GATE	2	25	1.27	25	S	P	†		MC10H158P	B MECLQD2I/P MULTIPLEXER	2	25	2.77	25	S	P	†			
MC10H115FN	B MECLQUADLINE RECEIVER	1	46	2.12	46	S	P			MC10H159L	B MECLQD2I/P MULTIPLEXER	3	25	8.70	25	S	P				
MC10H115FNR2	B MECLQUAD2I/P GATE	2	500	1.26	500	S	P			MC10H161FNR2	B MECLBIN TO1-OF-8DCDR	2	500	3.48	500	S	P				
MC10H115L	B MECLQUADLINE RECEIVER	3	25	4.15	25	S	P			MC10H164FN	B MECL8-LINE MULTIPLEXER	2	46	3.68	46	S	P				
MC10H115P	B MECLQUADLINE RECEIVER	1	25	1.27	25	S	P	†		MC10H164L	B MECL8-LINE MULTIPLEXER	3	25	8.27	25	S	P				
MC10H116D	B MECLTRIPLELINE RECEIVER	N	48	2.42	48	S	P			MC10H164P	B MECL8-LINE MULTIPLEXER	2	25	2.77	25	S	P	†			
MC10H116FN	B MECLTRIPLELINE RECEIVER	1	46	2.12	46	S	P			MC10H165L	B MECL8I/P PRIORITY ENCDR	3	25	25.63	25	S	P				
MC10H116FNR2	B MECLTRIPLELINE RECEIVER	2	500	1.26	500	S	P			MC10H166L	B MECL5-BIT MAG COMPARATOR	3	25	14.00	25	S	P				
MC10H116L	B MECLTRIPLELINE RECEIVER	2	25	2.28	25	S	P			MC10H172L	B MECLDLBIN/1-4DECDRHI	3	25	14.00	25	S	P				
MC10H116P	B MECLTRIPLELINE RECEIVER	1	25	1.27	25	S	P	†		MC10H174FN	B MECLDL4-TO-1MLTPLXR	2	46	3.68	46	S	P				
MC10H117FN	B MECLDL2WDOA/OAI	2	46	2.12	46	S	P			MC10H174FNR2	B MECLDL4-TO-1MLTPLXR	2	500	2.18	500	S	P				
MC10H117L	B MECLDL2WDOA/OAI	3	25	4.15	25	S	P			MC10H174L	B MECLDL4-TO-1MLTPLXR	3	25	8.27	25	S	P				
MC10H117P	B MECLDL2WDOA/OAI	2	25	1.27	25	S	P	†		MC10H174P	B MECLDL4-TO-1MLTPLXR	2	25	2.77	25	S	P	†			
MC10H123FN	B MECLTPL4-3-3I/PBUS DVR	2	46	2.53	46	S	P			MC10H175FN	B MECLQUINT LATCH	2	46	5.82	46	S	P				
MC10H123P	B MECLTPL4-3-3I/PBUS DVR	2	25	1.45	25	S	P	†		MC10H175L	B MECLQUINT LATCH	3	25	11.91	25	S	P				
MC10H124FN	B MECLQDTTL-TO-ECLXLTR	1	46	4.05	46	S	P			MC10H176FN	B MECLHEX DMSFF	2	46	6.27	46	S	P				
MC10H124FNR2	B MECLQDTTL-TO-ECLXLTR	2	500	2.42	500	S	P			MC10H176FNR2	B MECLHIFREQ	2	500	3.74	500	S	P				
MC10H124L	B MECLQDTTL-TO-ECLXLTR	2	25	5.00	25	S	P			MC10H176L	B MECLHEX DMSFF	3	25	11.91	25	S	P				
MC10H124P	B MECLQDTTL-TO-ECLXLTR	1	25	2.92	25	S	P	†		MC10H176P	B MECLHEX DMSFF	1	25	4.00	25	S	P	†			
MC10H125FN	B MECLQDECLTOTTLXLTR	1	46	4.05	46	S	P			MC10H179L	B MECLLOOKAHEAD CARRY BLK	3	25	11.91	25	S	P				
MC10H125FNR2	B MECLQDECLTOTTLXLTR	2	500	2.41	500	S	P			MC10H180L	B MECLDUAL2-BITADD/SUB	3	25	33.45	25	S	P				
MC10H125L	B MECLQDECLTOTTLXLTR	2	25	5.00	25	S	P			MC10H181P	B MECL4-BIT ALU/FUNCTNGEN	2	15	16.85	15	S	P	†			

A = OSPD/Power
B = Analog/Logic
J = Transportation
L = Consumer
N = Networking
V = Wireless

S = Proprietary Device
B = Motorola Blue Chip Program Device
P = Phoenix Program
★ = First Time in Book
† \$200 Minimum Waived

N = Key New Motorola Device
R = Key "Focus" Motorola Device

1 = Mature, Stable, High-Volume Device
2 = Moderate-Volume Device
3 = Low-Volume Device

EFFECTIVE DATE: JANUARY 10, 1998

COMMERCIAL COMPONENTS

Type No.	Grp/Description	Per Unit Sugg.			Factory		
		PC	Qty	Resale Price	Order	Incrmnt	
MC10H186FN	B MECLHEX-DFLIPFLOP	2	46	7.85	46	S	P
MC10H186P	B MECLHEX-DFLIPFLOP	2	25	6.03	25	S	P †
MC10H188FN	B MECLHEXBUFFERW/ENABLE	2	46	7.42	46	S	P
MC10H188L	B MECLHEXBUFFERW/ENABLE	2	25	6.55	25	S	P
MC10H188P	B MECLHEXBUFFERW/ENABLE	2	25	4.00	25	S	P †
MC10H189FN	B MECLHEXINVRTRW/ENABLE	2	46	7.42	46	S	P
MC10H189L	B MECLHEXINVRTRW/ENABLE	3	25	11.91	25	S	P
MC10H189P	B MECLHEXINVRTRW/ENABLE	2	25	4.00	25	S	P †
MC10H209L	B MECLDL4-5I/POR/NOR	3	25	8.09	25	S	P
MC10H209P	B MECLDL4-5I/POR/NOR	2	25	2.53	25	S	P †
MC10H210FN	B MECL3I/P3O/PORGATE	2	46	3.72	46	S	P
MC10H210L	B MECL3I/P3O/PORGATE	3	25	6.58	25	S	P
MC10H210P	B MECL3I/P3O/PORGATE	2	25	1.95	25	S	P †
MC10H211L	B MECL3I/P3O/PNORGATE	3	25	6.58	25	S	P
MC10H330FN	B MECL10HQUADMSTR	2	37	15.50	37	S	P
MC10H330L	B MECLQDBUSDRVR/RECEIVR	3	15	33.45	15	S	P
MC10H332L	B MECLDLBUSDRVR/RECEIVR	3	19	20.80	19	S	P
MC10H334L	B MECLQDBUSDRVR/RCVRT/R	3	19	23.94	19	S	P
MC10H350FN	B MECLTOTTLXLATOR	1	46	14.02	46	S	P
MC10H350FNR2	B MECLTOTTLXLATOR	2	500	14.10	500	S	P
MC10H350L	B MECLTOTTLXLATOR	2	25	16.92	25	S	P
MC10H350P	B MECLTOTTLXLATOR	1	25	10.07	25	S	P †
MC10H351FN	B TTL,NMOS TO ECL TRANSLTR	1	46	14.02	46	S	P
MC10H351L	B TTL,NMOS TO ECL TRANSLTR	3	19	26.80	19	S	P
MC10H351P	B TTL,NMOS TO ECL TRANSLTR	1	18	10.07	18	S	P †
MC10H352FN	B CMOS TO ECL TRANSLATOR	2	46	14.02	46	S	P
MC10H424FN	B MECLQDTTL-ECLXLATR	2	46	12.90	46	S	P
MC10H424L	B MECLQDTTL-ECLXLATR	3	25	26.80	25	S	P
MC10H424P	B MECLQDTTL-ECLXLATR	2	25	10.07	25	S	P †
MC10H600FN	B 9-BIT TTL-ECL TRANSLATOR	1	37	10.13	37		
MC10H601FN	B 9-BIT ECL-TTL TRANSLATOR	1	37	10.13	37		
MC10H602FN	B 9-BIT LATCH/TTL-ECLTRANS	1	37	11.43	37		
MC10H603FN	B 9-BIT LATCH/ECL-TTLTRANS	2	37	11.43	37		
MC10H604FN	B REG.TTL/ECLHEXTRANSLATR	N	37	11.43	37	S	P
MC10H605FN	B REGHEXECL/TTLTRNSLTR	N	37	11.43	37	S	P
MC10H606FN	B RGSTREDDTLPECLHEXTRNS	N	37	11.43	37	S	P
MC10H607FN	B REGHEXPECLTOTTLTRANS	N	37	11.43	37	S	P
MC10H640FN	B ECL/TTL CLOCK DRIVER	2	37	14.50	37		
MC10H640FNR2	B ECL/TTL CLOCK DRIVER	2	500	14.58	500		
MC10H641FN	B 1:9CLOCKDRIVER	1	37	10.00	37		
MC10H642FN	B ECL/TTL CLOCK DRIVER	N	37	14.50	37		
MC10H642FNR2	B ECL/TTL CLOCK DRIVER	2	500	8.14	500		
MC10H643FN	B 1:8CLOCKDRIVER	2	37	18.75	37		
MC10H644FN	B PECL/TTL CLOCK DRIVER	2	46	14.17	46		
MC10H645FN	B 1:9TTL CLOCK DRIVER	2	37	8.17	37		

Type No.	Grp/Description	Per Unit Sugg.			Factory		
		PC	Qty	Resale Price	Order	Incrmnt	
MC10H646FN	B PECL/TTL-TTL1:8DISTCHIP	N	37	11.67	37		
MC10H680FN	B QUADBUSTRS/RECECLDIFF	2	37	28.50	37	S	P
MC10SX1125D	B FIBEROPTICPOSTAMP	N	48	20.00	48	S	B
MC10SX1130D	B LEDDRIVER	N	48	5.95	48	S	B
MC10SX1189D	B FIBRECHANNELCIRCUIT	N	48	10.00	48		B
MC10SX1189DR2	B FIBRECHANNELCIRCUIT	2	2500	10.00	2500		B
MC100ELT20D	B TTL TO DIFF PECL TRANSLAT	N	98	6.78	98	S	P
MC100ELT21D	B DIFFRPECLTOTTLTRANS	N	98	6.78	98	S	P
MC100ELT22D	B DUAL TTL TO DIFF PECLTRS	2	98	6.78	98	S	P
MC100ELT22DR2	B DUAL TTL TO DIFF PECLTRS	2	2500	6.78	2500	S	P
MC100ELT23D	B DUALDIFFPECLTOTTLTRS	1	98	6.78	98	S	P
MC100ELT23DR2	B DUALDIFFPECLTOTTLTRS	2	2500	6.78	2500	S	P
MC100ELT24D	B DUAL TTL TO DIFF ECLTRAS	N	98	6.78	98	S	P
MC100ELT25D	B DIFFECLTOTTLTRANS	1	98	6.78	98	S	P
MC100ELT25DR2	B DIFFECLTOTTLTRANS	N	2500	6.78	2500	S	P
MC100ELT28D	B TTL/DIFPECLTRS DIFFPEC	N	98	6.78	98	S	P
MC100ELT28DR2	B TTL/DIFPECLTRS DIFFPEC	2	2500	6.78	2500	S	P
MC100EL01D	B 4-INPUTOR/NOR	2	98	8.33	98		
MC100EL01DR2	B 4-INPUTOR/NOR	2	2500	8.33	2500		
MC100EL04D	B 2-INPUTAND/NAND	2	98	8.33	98		
MC100EL04DR2	B 2-INPUTAND/NAND	2	2500	8.33	2500		
MC100EL05D	B 2-INPUTDIFFAND/NAND	2	98	8.33	98		
MC100EL05DR2	B 2-INPUTDIFFAND/NAND	2	2500	8.33	2500		
MC100EL07D	B 2-INPUTXOR/XNOR	2	98	8.33	98		
MC100EL07DR2	B 2-INPUTXOR/XNOR	2	2500	8.33	2500		
MC100EL11D	B 1:2DIFFERENTIALCLCKDVR	1	98	8.33	98		
MC100EL11DR2	B 1:2DIFFERENTIALCLCKDVR	2	2500	8.33	2500		
MC100EL12D	B DRIVER	2	98	8.33	98		
MC100EL12DR2	B DRIVER	2	2500	8.33	2500		
MC100EL13DW	B 2-BITDIFF/FN/BUF	N	38	10.72	38		
MC100EL13DWR2	B 2-BITDIFF/FN/BUF	2	1000	10.72	1000		
MC100EL14DW	B 1:5CLOCKDISTRIBCHIP	N	38	10.72	38		
MC100EL14DWR2	B 1:5CLOCKDISTRIBCHIP	2	1000	10.72	1000		
MC100EL15D	B 1:4CLOCKDISTRIBUTONCHIP	N	48	8.33	48		
MC100EL15DR2	B 1:4CLOCKDISTRIBUTONCHIP	2	2500	8.33	2500		
MC100EL16D	B DIFFERENTIALRECEIVER	1	98	8.33	98		
MC100EL16DR2	B DIFFERENTIALRECEIVER	2	2500	8.33	2500		
MC100EL17DW	B QUADDIFFERENTIALRECIVER	N	38	10.72	38		
MC100EL17DWR2	B QUADDIFFERENTIALRECIVER	2	1000	10.72	1000		
MC100EL29DW	B 2-BITDIFF.F/FW/REST/SET	N	38	10.72	38		
MC100EL29DWR2	B 2-BITDIFF.F/FW/REST/SET	2	1000	10.72	1000		
MC100EL30DW	B 3-BIT S.E. RESET D/F/W	N	38	10.72	38		
MC100EL30DWR2	B 3-BIT S.E. RESET D/F/W	2	1000	10.72	1000		
MC100EL31D	B DFLIPFLOPSET&RESET	2	98	8.33	98		
MC100EL31DR2	B DFLIPFLOPSET&RESET	2	2500	8.33	2500		

A = OSPD/Power
 B = Analog/Logic
 J = Transportation
 L = Consumer
 N = Networking
 V = Wireless

S = Proprietary Device
 B = Motorola Blue Chip Program Device
 P = Phoenix Program
 * = First Time in Book
 † \$200 Minimum Waived

N = Key New Motorola Device
 R = Key "Focus" Motorola Device

1 = Mature, Stable, High-Volume Device
 2 = Moderate-Volume Device
 3 = Low-Volume Device

COMMERCIAL COMPONENTS

Type No.	Grp/Description	Per Unit Sugg. Factory		Order		Type No.	Grp/Description	Per Unit Sugg. Factory		Order					
		PC	Qty					Price	Price			PC	Qty	Price	Price
MC100EL32D	B +2 DIVIDER DIFRNTAL INPUT	2	98	8.33	98	MC100E151FNR2	B 6-BIT D REGISTER	2	500	25.67	500				
MC100EL32DR2	B +2 DIVIDER DIFRNTAL INPUT	2	2500	8.33	2500	MC100E155FN	B 6-BIT 2:1 MUX-LATCH	2	37	25.67	37				
MC100EL33D	B +4 DIVIDER DIFRNTAL INPUT	2	98	8.33	98	MC100E155FNR2	B 6-BIT 2:1 MUX-LATCH	2	500	25.67	500				
MC100EL33DR2	B +4 DIVIDER DIFRNTAL INPUT	2	2500	8.33	2500	MC100E156FN	B 3-BIT 4:1 MUX-LATCH	2	37	25.67	37				
MC100EL34D	B DIVIDE BY 2, 4, 8 CLOCK	N	48	8.33	48	MC100E157FN	B 4-BIT 2:1 MULTIPLEXER	2	37	21.92	37				
MC100EL35D	B JK FLIP-FLOP	N	98	8.33	98	MC100E158FN	B 5-BIT 2:1 MULTIPLEXER	N	37	21.92	37				
MC100EL35DR2	B JK FLIP-FLOP	2	98	8.33	98	MC100E160FN	B 12 BIT PARITY	2	37	25.67	37				
MC100EL38DW	B CLOCK GENERATION CHIP	N	38	8.33	38	MC100E160FNR2	B 12 BIT PARITY	2	500	25.67	500				
MC100EL38DWR2	B CLOCK GENERATION CHIP	2	1000	8.33	1000	MC100E163FN	B 2-BIT 8:1 MULTIPLEXER	N	37	21.92	37				
MC100EL39DW	B CLOCK GENERATION CHIP	N	38	10.72	38	MC100E163FNR2	B 2-BIT 8:1 MULTIPLEXER	2	500	21.92	500				
MC100EL39DWR2	B CLOCK GENERATION CHIP	2	1000	10.72	1000	MC100E164FN	B 16:1 MULTIPLEXER	2	37	21.92	37				
MC100EL51D	B DIFF CLOCK D FLIP FLOP	2	98	8.33	98	MC100E166FN	B 9-BIT MAGNITUDE COMP	2	37	25.67	37				
MC100EL51DR2	B DIFF CLOCK D FLIP FLOP	2	2500	8.33	2500	MC100E167FN	B 6-BIT 2:1 MUX-REGISTER	N	37	25.67	37				
MC100EL52D	B DIFF DATA/D FLIP FLOP	2	98	8.33	98	MC100E167FNR2	B 6-BIT 2:1 MUX-REGISTER	2	500	25.67	500				
MC100EL52DR2	B DIFF DATA/D FLIP FLOP	2	2500	8.33	2500	MC100E171FN	B 3-BIT 4:1 MULTIPLEXER	2	37	21.92	37				
MC100EL56DW	B 2-BIT DIFF 2:1 MULTIPLEXR	N	38	10.72	38	MC100E171FNR2	B 3-BIT 4:1 MULTIPLEXER	2	500	21.92	500				
MC100EL56DWR2	B 2-BIT DIFF 2:1 MULTIPLEXR	2	1000	10.72	1000	MC100E175FN	B 9-BIT LATCH WITH PARITY	2	37	25.67	37				
MC100EL57D	B 4:1 DIFRNTAL MULTIPLXER	1	48	8.33	48	MC100E195FN	B PROGRAMMABLE DELAY CHIP	2	37	29.17	37				
MC100EL57DR2	B 4:1 DIFRNTAL MULTIPLXER	2	2500	8.33	2500	MC100E196FN	B PROGRAMMABLE DELAY CHIP	2	37	29.17	37				
MC100EL58D	B 2:1 MULTIPLEXER	1	98	8.33	98	MC100E210FN	B DUAL CLOCK DRIVER	N	37	21.88	37				
MC100EL58DR2	B 2:1 MULTIPLEXER	2	2500	8.33	2500	MC100E210FNR2	B DUAL CLOCK DRIVER	2	500	21.97	500				
MC100EL59DW	B 3-BIT S.E. 2:1 MULTIPLXER	N	38	14.82	38 S P	MC100E211FN	B 6BIT DIFRNTL CLK DRVR	N	37	21.88	37				
MC100EL90DW	B 3-BIT MECL/PECL TRANSLATR	N	38	10.72	38	MC100E211FNR2	B 6-BIT DIFRNTAL CLK DRVER	2	500	21.97	500				
MC100EL90DWR2	B 3-BIT MECL/PECL TRANSLATR	2	1000	10.72	1000	MC100E212FN	B 3BIT SCAN REGIST ADD DRIV	N	37	18.33	37				
MC100E016FN	B 3-BIT 4:1 MUX LATCH	1	37	22.50	37	MC100E310FN	B 2:8 DIFF FANOUT BUFFER	N	37	21.88	37				
MC100E101FN	B 4-BIT INPUT OR/NOR GATE	2	37	18.33	37	MC100E310FNR2	B 2:8 DIFF FANOUT BUFFER	2	500	21.97	500				
MC100E104FN	B 5-BIT 2-IN AND/NAND GATE	N	37	18.33	37	MC100E337FN	B 3-BIT SCAN REGIST BUS TRA	N	37	21.92	37				
MC100E104FNR2	B 5-BIT 2-IN AND/NAND GATE	2	500	18.33	500	MC100E337FNR2	B 3-BIT SCAN REGIST BUS	2	500	21.92	500				
MC100E107FN	B 5-BIT 2-IN XOR/NOR GATE	N	37	18.33	37	MC100E404FN	B 4-B DIFFERENTIAL AND/NAND	2	37	18.33	37				
MC100E107FNR2	B 5-BIT 2-IN XOR/NOR GATE	2	500	18.33	500	MC100E416FN	B QUINT DIFF LINE RECVR	2	37	18.33	37				
MC100E111FN	B 1:9 DIFFERENTIAL CLOCK DR	1	37	21.88	37	MC100E416FNR2	B QUINT DIFF LINE RECVR	N	500	18.42	500 *				
MC100E111FNR2	B 1:9 DIFFERENTIAL CLOCK DR	N	500	21.97	500	MC100E431FN	B 3-BIT DIFFERENT FLIP/FLOP	2	37	21.92	37				
MC100E112FN	B 4-BIT DRVR COMMON ENABLE	N	37	18.33	37	MC100E445FN	B 4-BIT PARALLEL CONVERTER	N	37	29.17	37				
MC100E112FNR2	B 4-BIT DRVR COMMON ENABLE	2	500	18.33	500	MC100E445FNR2	B 4-BIT PARALLEL CONVERTER	2	500	29.17	500				
MC100E116FN	B 5-BIT DIFF LINE RECEIVER	1	37	18.33	37	MC100E446FN	B 4-BIT PARALLEL/SERIAL CONV	N	37	29.17	37				
MC100E122FN	B 9-BIT BUFFER	2	37	18.33	37	MC100E452FN	B 5-BIT DIFFERENTIAL REGIST	2	37	25.67	37				
MC100E131FN	B 4-BIT D FLIP/FLOP	1	37	21.92	37	MC100E457FN	B 3-B DIF 2:1 MULTIPLEXER	2	37	21.92	37				
MC100E136FN	B 6-BIT UNIV COUNTER	2	37	29.17	37	MC100H600FN	B 9-BIT TTL-ECL TRANSLATOR	2	37	13.75	37				
MC100E137FN	B 8-BIT RIPPLE COUNTER	2	37	29.17	37	MC100H601FN	B 9-BIT ECL-TTL TRANSLATOR	2	37	13.75	37				
MC100E137FNR2	B 8-BIT RIPPLE COUNTER	2	500	29.17	500	MC100H602FN	B 9-BIT LATCH/TTL-ECL TRANS	2	37	15.52	37				
MC100E141FN	B 8-BIT SHIFT REGISTER	1	37	25.67	37	MC100H602FNR2	B 9-BIT LATCH/TTL-ECL TRANS	2	500	15.60	500				
MC100E141FNR2	B 8-BIT SHIFT REGISTER	N	500	25.67	500	MC100H603FN	B 9-BIT LATCH/ECL-TTL TRANS	2	37	15.52	37				
MC100E142FN	B 9-BIT SHIFT REGISTER	1	37	29.17	37	MC100H604FN	B REG. TTL/ECL HEX TRANSLATR	N	37	11.43	37 S P				
MC100E143FN	B 9-BIT HOLD REGISTER	N	37	29.17	37	MC100H605FN	B REG HEX ECL/TTL TRNSLTR	N	37	11.43	37 S P				
MC100E151FN	B 6-BIT D REGISTER	2	37	25.67	37	MC100H606FN	B RGSTRED TTL PECL HEX TRNS	N	37	11.43	37 S P				

A = OSPD/Power
 B = Analog/Logic
 J = Transportation
 L = Consumer
 N = Networking
 V = Wireless

S = Proprietary Device
 B = Motorola Blue Chip Program Device
 P = Phoenix Program
 * = First Time in Book
 † = \$200 Minimum Waived

N = Key New Motorola Device
 R = Key "Focus" Motorola Device

1 = Mature, Stable, High-Volume Device
 2 = Moderate-Volume Device
 3 = Low-Volume Device

EFFECTIVE DATE: JANUARY 10, 1998

COMMERCIAL COMPONENTS

Type No.	Grp/Description	Per Unit Sugg. Factory					
		Resale Price	Price	Order			
PC	Qty	Price	Incrmnt				
MC100H607FN	B REGHEXPECL TO TTL TRANS	N	37	11.43	37	S	P
MC100H607FNR2	B REGHEXPECL TO TTL TRANS	2	500	11.52	500		
MC100H640FN	B ECL/TTL CLOCK DRIVER	2	37	14.50	37		
MC100H640FNR2	B ECL/TTL CLOCK DRIVER	2	500	14.58	500		
MC100H641FN	B 1:9 CLOCK DRIVER	2	37	10.00	37		
MC100H643FN	B 1:8 CLOCK DRIVER	2	37	18.75	37		
MC100H644FN	B PECL/TTL CLOCK DRIVER	N	46	14.17	46		
MC100H646FN	B PECL/TTL-TTL1:8DISTCHIP	N	37	11.67	37		
MC100H646FNR2	B PECL/TTL-TTL1:8DISTCHIP	N	500	11.75	500		
MC100H680FN	B QUAD BUS TRS/REC ECL DIFF	2	37	28.50	37	S	P
MC100H680FNR2	B QUAD BUS TRS/REC ECL DIFF	N	500	28.58	500	S	P
MC100H681FN	B HEX TTL BUS/ECL/TRS/W/LAC	2	37	28.50	37	S	P
MC100H681FNR2	B HEX TTL BWS/ECL/TRS/W/LAC	N	500	28.58	500	S	P
MC100LVEL01D	B LOW VOLT4-INPTOR/NOR	N	98	9.00	98	S	P
MC100LVEL01DR2	B LOW VOLT4-INPTOR/NOR	2	2500	9.00	2500	S	P
MC100LVEL11D	B 1:2 DIFF LOW VOLT FAN BUF	N	98	8.33	98		
MC100LVEL11DR2	B 1:2 DIFF LOW VOLT FAN BUF	2	2500	8.33	2500		
MC100LVEL13DW	B LO/VOLT2-BIT DIFF/FN/BUF	N	38	14.82	38	S	P
MC100LVEL13DWR2	B LO/VOLT2-BIT DIFF/FN/BUF	2	1000	14.82	1000	S	P
MC100LVEL14DW	B LOW VOLT1:5 CLCK DISCHP	N	38	14.82	38	S	P
MC100LVEL14DWR2	B LOW VOLT1:5 CLCK DISCHP	2	1000	14.82	1000	S	P
MC100LVEL16D	B LOW VOLT DIFFERENTIAL RECVR	N	98	8.33	98		
MC100LVEL16DR2	B LOW VOLT DIFFERENTIAL RECVR	2	2500	8.33	2500		
MC100LVEL17DW	B LOW VOLT QUAD DIFFNTAL	N	38	14.82	38	S	P
MC100LVEL17DWR2	B LOW VOLT QUAD DIFFNTAL	2	1000	14.82	1000	S	P
MC100LVEL29DW	B LOW VOLT2-BIT DIFF	N	38	14.82	38	S	P
MC100LVEL29DWR2	B LOW VOLT2-BIT DIFF	2	1000	14.82	1000	S	P
MC100LVEL30DW	B LOW VOLT3-BIT S.E.RESET	N	38	14.82	38	S	P
MC100LVEL30DWR2	B LOW VOLT3-BIT S.E.RESET	2	1000	14.82	1000	S	P
MC100LVEL31D	B LOW VOLT D/F/W/SET/RES	N	98	8.33	98		
MC100LVEL31DR2	B LOW VOLT D/F/W/SET/RES	2	2500	8.33	2500		
MC100LVEL32D	B LOW VOL/2 DIVIDER	N	98	9.00	98	S	P
MC100LVEL32DR2	B LOW VOL/2 DIVIDER	2	2500	9.00	2500	S	P
MC100LVEL33D	B LOW VOL DIV BY4 DIVIDER	N	98	9.00	98	S	P
MC100LVEL33DR2	B LOW VOL DIV BY4 DIVIDER	2	2500	9.00	2500	S	P
MC100LVEL38DW	B +2+4/6 CLCK GENCHIP	N	38	8.33	38		
MC100LVEL38DWR2	B +2+4/6 CLCK GENCHIP	2	1000	8.33	1000		
MC100LVEL39DW	B LOW VOT CLOCK GENRAT CHIP	N	38	14.82	38	S	P
MC100LVEL39DWR2	B LOW VOT CLOCK GENRAT CHIP	2	1000	14.82	1000	S	P
MC100LVEL51D	B LOW VOLT DIFF CLOCK D/F/F	N	98	9.00	98	S	P
MC100LVEL51DR2	B LOW VOLT DIFF CLOCK D/F/F	2	2500	9.00	2500	S	P
MC100LVEL56DW	B LOW VOLT2-BIT DIFF2:1	N	38	14.82	38	S	P
MC100LVEL56DWR2	B LOW VOLT2-BIT DIFF2:1	2	1000	14.82	1000	S	P
MC100LVEL59DW	B 3-BIT S.E.2:1 MULTIPLEXR	N	38	14.82	38	S	P
MC100LVEL59DWR2	B 3-BIT S.E.2:1 MULTIPLEXR	2	1000	14.82	1000	S	P

Type No.	Grp/Description	Per Unit Sugg. Factory					
		Resale Price	Price	Order			
PC	Qty	Price	Incrmnt				
MC100LVEL90DW	B LOW VOLT3-BT ME/PE TRSLT	N	38	14.82	38	S	P
MC100LVEL90DWR2	B LOW VOLT3-BT ME/PE TRSLT	2	1000	14.82	1000	S	P
MC100LVE111FN	B LOW VOLT1:9 DIF CLOCK DR	N	37	21.88	37		
MC100LVE111FNR2	B LOW VOLT1:9 DIF CLOCK DR	2	500	21.97	500		
MC100LVE164FA	B 16:1 MULTIPLEXER	N	250	29.73	250	S	P
MC100LVE210FN	B DUAL CLOCK DRIVER	N	37	21.88	37		
MC100LVE210FNR2	B DUAL CLOCK DRIVER	2	500	21.97	500		
MC100LVE310FN	B LOW VOLT2:8 DIFF FAN BUF	N	37	21.88	37		
MC100LVE310FNR2	B LOW VOLT2:8 DIFF FAN BUF	2	500	21.97	500		
MC100SX1230FN	B CMICODER/DECODER	N	37	36.68	37	S	B
MC10101FNR2	B MECL QUAD OR/NOR GATE	2	500	1.43	500	S	P
MC10101L	B MECL QUAD OR/NOR GATE	3	25	3.76	500	S	P
MC10101P	B MECL QUAD OR/NOR GATE	2	25	.73	500	S	P
MC10102FN	B MECL QUAD2 I/P NOR GATE	2	46	2.07	46	S	P
MC10102L	B MECL QUAD2 I/P NOR GATE	2	25	2.07	500	S	P
MC10102P	B MECL QUAD2 I/P NOR GATE	2	25	.87	500	S	P
MC10103FN	B MECL QUAD2 I/P OR GATE	N	46	2.07	46	S	P
MC10103L	B MECL QUAD2 I/P OR GATE	3	25	3.76	500	S	P
MC10103P	B MECL QUAD2 I/P OR GATE	2	25	.87	500	S	P
MC10104L	B MECL QUAD2 I/P AND GATE	2	25	2.07	500	S	P
MC10104P	B MECL QUAD2 I/P AND GATE	2	25	.73	500	S	P
MC10105FN	B MECL TRPL2-3-2 I/P OR/NOR	N	46	2.07	46	S	P
MC10105FNR2	B MECL QUAD ECL/TTL XLTR	2	500	1.42	500	S	P
MC10105L	B MECL TRPL2-3-2 I/P OR/NOR	3	25	3.76	500	S	P
MC10105P	B MECL TRPL2-3-2 I/P OR/NOR	2	25	.87	500	S	P
MC10106L	B MECL TRPL4-3-3 I/P NOR	3	25	3.76	500	S	P
MC10107FN	B MECL TRPLEXCOR/NOR	2	46	2.07	46	S	P
MC10107L	B MECL TRPLEXCOR/NOR	3	25	3.88	500	S	P
MC10107P	B MECL TRPLEXCOR/NOR	2	25	.87	500	S	P
MC10109P	B MECL DUAL4-5 I/P OR/NOR	2	25	.82	500	S	P
MC10111P	B LAST ORDER DATE:12/02/98	N	25	.87	500	S	P
MC10113L	B MECL QUAD EXC OR GATE	3	25	3.58	500	S	P
MC10113P	B MECL QUAD EXC OR GATE	2	25	.87	500	S	P
MC10114FN	B MECL TRIPLE LINE RECEIVER	2	46	2.07	46	S	P
MC10114FNR2	B MECL TRIPLE LINE RECEIVER	2	500	1.51	500	S	P
MC10114L	B MECL TRIPLE LINE RECEIVER	3	25	3.79	500	S	P
MC10114P	B MECL TRIPLE LINE RECEIVER	2	25	.87	500	S	P
MC10115FN	B MECL QUAD LINE RECIEVER	2	46	2.07	46	S	P
MC10115FNR2	B MECL QUAD LINE RECIEVER	2	500	2.15	500	S	P
MC10115L	B MECL QUAD LINE RECIEVER	2	25	2.02	500	S	P
MC10115P	B MECL QUAD LINE RECIEVER	2	25	.87	500	S	P
MC10116FN	B MECL TRIPLE LINE RECEIVER	1	46	2.07	46	S	P
MC10116FNR2	B MECL TRIPLE LINE RECEIVER	2	500	1.51	500	S	P
MC10116L	B MECL TRIPLE LINE RECEIVER	2	25	1.20	500	S	P
MC10116P	B MECL TRIPLE LINE RECEIVER	1	25	.87	500	S	P

A = OSPD/Power
 B = Analog/Logic
 J = Transportation
 L = Consumer
 N = Networking
 V = Wireless

S = Proprietary Device
 B = Motorola Blue Chip Program Device
 P = Phoenix Program
 * = First Time in Book
 † = \$200 Minimum Waived

N = Key New Motorola Device
 R = Key "Focus" Motorola Device

1 = Mature, Stable, High-Volume Device
 2 = Moderate-Volume Device
 3 = Low-Volume Device

COMMERCIAL COMPONENTS

Type No.	Grp/Description	Per Unit Sugg. Factory				PC	Qty	Price	Order	Incrrmnt	Type No.	Grp/Description	Per Unit Sugg. Factory				PC	Qty	Price	Order	Incrrmnt
		Resale	Price	Order	Incrrmnt								Resale	Price	Order	Incrrmnt					
MC10117FN	B MECLDL2WDOA/OAI	N	46	2.07	46	S	P			MC10175L	B MECLQUINT LATCH	3	25	9.24	25	S	P				
MC10117L	B MECLDL2WDOA/OAI	3	25	3.11	500	S	P			MC10176L	B MECLHEX"D"MSTRSLVFF	2	25	6.55	25	S	P				
MC10117P	B MECLDL2WDOA/OAI	2	25	.80	500	S	P			MC10176P	B MECLHEX"D"MSTRSLVFF	2	25	4.00	25	S	P				
MC10121L	B MECL4WDO-A/O-A-INVRT	3	25	3.18	500	S	P			MC10178L	B MECLBINARY COUNTER	3	25	18.27	25	S	P				
MC10123L	B MECLTRPL4-3-3I/PBUSDR	3	25	3.24	500	S	P			MC10178P	B MECLBINARY COUNTER	2	25	7.35	25	S	P				
MC10123P	B MECLTRPL4-3-3I/PBUSDR	2	25	.92	500	S	P			MC10186L	B MECLHEXDMSTRSLVFF/RS	3	25	13.70	25	S	P				
MC10124FN	B MECLQUAD TTL/ECLXLTR	2	46	3.05	46	S	P			MC10186P	B MECLHEXDMSTRSLVFF/RS	2	25	4.57	25	S	P				
MC10124FNR2	B MECLQUADECL/TTLXLTR	2	500	1.82	500	S	P			MC10188FN	B MECLHEXBUFFER/WENABLE	N	46	5.37	46	S	P				
MC10124L	B MECLQUAD TTL/ECLXLTR	2	25	3.25	25	S	P			MC10188L	B MECLHEXBUFFER/WENABLE	3	25	7.42	25	S	P				
MC10124P	B MECLQUAD TTL/ECLXLTR	1	25	1.92	25	S	P			MC10188P	B MECLHEXBUFFER/WENABLE	2	25	2.48	25	S	P				
MC10125FN	B MECLQUADECL/TTLXLTR	1	46	3.05	46	S	P			MC10189L	B MECLHEXINVRTW/ENABLE	3	25	7.42	25	S	P				
MC10125FNR2	B MECLQUADECL/TTLXLTR	2	500	1.82	500	S	P			MC10189P	B MECLHEXINVRTW/ENABLE	2	25	2.48	25	S	P				
MC10125L	B MECLQUADECL/TTLXLTR	2	25	3.25	25	S	P			MC10192FN	B MECLQUADBUS DRIVER	2	46	5.32	46	S	P				
MC10125P	B MECLQUADECL/TTLXLTR	1	25	1.92	25	S	P			MC10192L	B MECLQUADBUS DRIVER	3	25	11.54	25	S	P				
MC10131FN	B MECLDL TYP DMSTRSLVFF	2	46	3.40	46	S	P			MC10192P	B MECLQUADBUS DRIVER	2	25	4.07	25	S	P				
MC10131L	B MECLDL TYP DMSTRSLVFF	2	25	3.67	25	S	P			MC10195L	B MECLHEXINVRTR/BUFFER	3	25	5.64	25	S	P				
MC10131P	B MECLDL TYP DMSTRSLVFF	1	25	2.17	25	S	P			MC10197L	B MECLHEX"AND" GATE	3	25	5.61	25	S	P				
MC10135FNR2	B MECLDLJ-KMSTRSLVFF	2	500	2.40	500	S	P			MC10198FN	B MECLMONOSTBLEMULTIVBRTR	2	46	18.82	46	S	P				
MC10135L	B MECLDLJ-KMSTRSLVFF	3	25	7.48	25	S	P			MC10198L	B MECLMONOSTBLEMULTIVBRTR	2	25	25.10	25	S	P				
MC10135P	B MECLDLJ-KMSTRSLVFF	2	25	2.62	25	S	P			MC10198P	B MECLMONOSTBLEMULTIVBRTR	1	25	16.00	25	S	P				
MC10136FN	B MECLUNIVRSLHXADCMLCNTR	2	46	14.13	46	S	P			MC10210L	B MECLDL3I/P3O/PORGATE	3	25	4.79	25	S	P				
MC10136L	B MECLUNIVRSLHXADCMLCNTR	2	25	16.75	25	S	P			MC10216FN	B MECLHISPDRPLNE RCVR	2	46	2.68	46	S	P				
MC10136P	B MECLUNIVRSLHXADCMLCNTR	2	25	10.18	25	S	P			MC10216L	B MECLHISPDRPLNE RCVR	3	25	4.79	25	S	P				
MC10137L	B MECLUNIVERSLDECADE CNTR	3	25	26.53	25	S	P			MC10216P	B MECLHISPDRPLNE RCVR	2	25	1.43	25	S	P				
MC10137P	B MECLUNIVERSLDECADE CNTR	2	25	10.75	25	S	P			MC10231P	B MECLHISPDDLMSFF	2	25	4.30	25	S	P				
MC10138L	B MECLBI-QUINARY COUNTER	3	25	19.56	25	S	P			MC12002L	V LAST ORDER DATE:12/01/98	3	25	16.29	25	S					
MC10138P	B MECLBI-QUINARY COUNTER	1	25	7.92	25	S	P			MC12002P	V MECLANALOG MIXER	2	25	8.54	25	S	P				
MC10141L	B MECL4-BIT UNIV SHFT REG	2	25	6.53	25	S	P			MC12009D	V TWOMODULUSPRESCALER	N	48	10.71	48	★					
MC10141P	B MECL4-BIT UNIV SHFT REG	2	25	3.98	25	S	P			MC12009L	V LAST ORDER DATE:12/01/98	2	25	18.47	25						
MC10153L	B MECLQUAD LATCH	3	25	7.91	25	S	P			MC12009P	V MECL2-MODULUSPRESCALER	2	25	10.71	25						
MC10158FNR2	B MECLQD2I/PMULTIPLXR	2	500	2.71	500	S	P			MC12011FN	V MECL2-MODULUSPRESCALER	2	46	13.80	46						
MC10158L	B MECLQD2I/PMULTIPLXR	3	25	8.27	25	S	P			MC12011P	V MECL2-MODULUSPRESCALER	2	25	11.33	25						
MC10158P	B MECLQD2I/PMULTIPLXR	2	25	2.77	25	S	P			MC12013D	V TWOMODULUSPRESCALER	N	48	14.62	48						
MC10159L	B MECLQD2I/PMULTIPLXR	3	25	8.27	25	S	P			MC12013FN	V MECL2-MODULUSPRESCALER	2	46	13.95	46						
MC10161L	B MECLBINARY/1-8DECDRLO	3	25	8.27	25	S	P			MC12013L	V LAST ORDER DATE:12/01/98	2	25	17.43	25						
MC10161P	B MECLBINARY/1-8DECDRLO	2	25	2.77	25	S	P			MC12013P	V MECL2-MODULUSPRESCALER	1	25	14.62	25						
MC10162L	B MECLBINARY/1-8DECDRHI	3	25	8.27	25	S	P			MC12015D	V LOWPOWERPRESCALER	2	98	7.50	98	S	P				
MC10164L	B MECL8-LINEMULTIPLXER	2	25	4.55	25	S	P			MC12015P	V MECLLOPWR2-MODPRSCLR	2	50	7.96	50	S	P				
MC10164P	B MECL8-LINEMULTIPLXER	2	25	2.77	25	S	P			MC12016D	V LOWPOWERPRESCALER	2	98	7.96	98	S	P				
MC10166L	B MECL5-BITMAG COMPARATOR	3	25	14.00	25	S	P			MC12016P	V MECLLOPWR2-MODPRSCLR	2	50	7.96	50	S	P				
MC10171L	B MECLBINARY/1-4DECDRLO	3	25	10.09	25	S	P			MC12017D	V LOWPOWERPRESCALER	2	98	7.96	98	S	P				
MC10173L	B MECLQD2I/MLTPLXR/LTCH	3	25	8.27	25	S	P			MC12017DR2	V MECLLOPWR2-MODPRSCLR	2	2500	8.00	2500	S	P				
MC10174L	B MECLDL4TO1MULTIPLXR	3	25	8.27	25	S	P			MC12017P	V MECLLOPWR2-MODPRSCLR	1	50	7.96	50	S	P				
MC10174P	B MECLDL4TO1MULTIPLXR	2	25	2.77	25	S	P			MC12018DR2	V MECL%128/129LOPWRPSCL	2	2500	21.29	2500	S	P				
MC10175FN	B MECLQUINT LATCH	N	46	4.78	46	S	P			MC12018P	V MECL%128/129LOPWRPSCL	2	50	21.24	50	S	P				

A = OSPD/Power
 B = Analog/Logic
 J = Transportation
 L = Consumer
 N = Networking
 V = Wireless

S = Proprietary Device
 B = Motorola Blue Chip Program Device
 P = Phoenix Program
 ★ = First Time in Book
 † \$200 Minimum Waived

N = Key New Motorola Device
 R = Key "Focus" Motorola Device

1 = Mature, Stable, High-Volume Device
 2 = Moderate-Volume Device
 3 = Low-Volume Device

EFFECTIVE DATE: JANUARY 10, 1998

COMMERCIAL COMPONENTS

Type No.	Grp/Description	Per Unit Sugg.			Factory Order
		PC Qty	Resale Price	Price Incrmt	
MC12019D	V PLLLOPOWER2MODPRESCLR	2	98	7.96	98 S P
MC12019P	V MECL%20/21LOPWRPRSCLR	2	50	7.96	50 S P
MC12022AD	V LWPWR2-MODULRPRESALER	1	98	5.35	98
MC12022ADR2	V LWPWR2-MODPRESALER	2	2500	5.38	2500
MC12022AP	V LWPWR2-MODULRPRESALER	2	50	5.35	50
MC12022BDR2	V LWPWR2-MODPRESALER	2	2500	5.38	2500
MC12022LVAD	V LWPWR2-MODULRPRESALER	N	98	6.15	98
MC12022LVAP	V LOWVOLT2-MODPRESALER	N	50	6.15	50
MC12022LVBD	V LWPWR2-MODULRPRESALER	N	98	6.15	98
MC12022LVBP	V LOWVOLT2-MODPRESALER	N	50	6.15	50
MC12022TSAD	V LASTORDERDATE:12/01/98	N	98	6.15	98
MC12022TSAP	V LASTORDERDATE:12/01/98	N	50	6.15	50
MC12022TVAD	V LASTORDERDATE:12/01/98	N	98	6.15	98
MC12022TVAP	V LASTORDERDATE:12/01/98	N	50	6.15	50
MC12023D	V PLLLOPOWERPRESALER	2	98	9.63	98 S P
MC12025P	V LASTORDERDATE:12/01/98	N	50	7.48	50 S
MC12026AD	V 2-MODPRESCER6/7&16/17	1	98	8.13	98 S P
MC12026ADR2	V 2-MODPRESCER6/7&16/17	2	2500	8.17	2500 S
MC12026AP	V 2-MODPRESCER6/7&16/17	N	50	8.13	50 S P
MC12026ASD	V 2-MODPRESCER6/7&16/17	N	156	7.02	156 S P
MC12026BD	V 2-MODPRESCER6/7&16/17	N	98	6.68	98 S P
MC12026BP	V 2-MODPRESCER6/7&16/17	N	50	6.68	50 S P
MC12026BSD	V 2-MODPRESCER6/7&16/17	N	156	7.02	156 S P
MC12028AD	V LOWPOWER2-MODULUSPRESC	1	98	6.33	98 S P
MC12028AP	V LOWPOWER2-MODULUSPRESC	2	50	6.33	50 S P
MC12032AD	V LWPWR2-MODULRPRESALER	N	98	7.33	98 S
MC12033AD	V LOWPOWERHIFREQPRESCAL	N	98	8.56	98 S P
MC12033AP	V LOWPOWERHIFREQPRESCAL	N	50	8.56	50 S P
MC12033BD	V LOWPOWERHIFREQPRESCAL	N	98	7.48	98 S P
MC12033BP	V LOWPOWERHIFREQPRESCAL	N	50	7.48	50 S P
MC12034AD	V LWPWR2-MODHIFREQPRS	2	98	7.48	98 S P
MC12034ADR2	V LWPWR2-MODHIFREQPRS	2	2500	7.53	2500 S
MC12038AD	V LOWPOW2MODULUSPRESCAL	N	98	8.02	98
MC12038AP	V LOWPOW2MODULUSPRESCAL	N	50	8.02	50
MC12040FN	V MECLPHASE-FREQ.DETCETOR	2	46	12.10	46 S
MC12040FNR2	V MECLPHASE-FREQ.DETCETOR	2	1000	12.13	1000 S
MC12040L	V LASTORDERDATE:12/01/98	2	25	15.33	25 S
MC12040P	V MECLPHASE-FREQ.DETCETOR	1	25	10.75	25 S P
MC12052AD	V LOWPOWER2-MODPRESALER	N	98	4.26	98 S B
MC12053AD	V 2-MODPRSLR64/65&128/129	N	98	4.26	98 S P
MC12054AD	V LOWPOW2MODHIFRQPSLR	N	98	4.26	98 S P
MC12058D	V 2MODPSLR126/128/254/256	N	98	6.88	98 S P
MC12061L	V LASTORDERDATE:12/01/98	3	25	13.39	25 S P
MC12061P	V MECLCRYSTALOSCILLATOR	2	25	5.38	25 S P
MC12066D	V DIV64-256PRESCLLOWHAR	N	98	5.72	98 *S P

Type No.	Grp/Description	Per Unit Sugg.			Factory Order
		PC Qty	Resale Price	Price Incrmt	
MC12066DR2	V DIV64-256PRESCLLOWHAR	N	2500	6.88	2500 *S P
MC12066P	V DIV64-256PRESCLLOWHAR	N	50	6.84	50 *S P
MC12073D	V LASTORDERDATE:12/01/98	N	98	8.48	98
MC12073P	V LASTORDERDATE:12/01/98	2	50	7.92	50
MC12074D	V LASTORDERDATE:12/01/98	2	98	8.48	98 S
MC12075D	V LASTORDERDATE:12/01/98	N	98	6.88	98
MC12076D	V LASTORDERDATE:12/01/98	2	98	6.88	98
MC12079D	V LOWPOWMUL-MODHIFREQP	2	98	6.41	98
MC12079DR2	V LOWPOWMUL-MODHIFREQP	N	2500	5.00	2500
MC12079P	V LOWPOWMUL-MODHIFREQP	N	50	6.41	50
MC12080D	V LOWPOWMULTMODHIFREQUE	N	98	10.71	98 S P
MC12080P	V LOWPOWMULTMODHIFREQUE	N	50	10.71	50 S P
MC12083D	V LOWPOWPRESALER%2	N	98	6.15	98 S
MC12083P	V LASTORDERDATE:12/01/98	N	50	6.15	50 S
MC12089D	V 64/1282.8GHZPRESALER	N	98	6.41	98
MC12089P	V 64/1282.8GHZPRESALER	N	50	6.41	50
MC12090L	V LASTORDERDATE:12/01/98	3	25	14.34	25 S
MC12093D	V LOWPOWPRESCLER%2,4,8	N	98	7.48	98 B
MC12093DR2	V LOWPOWPRESCLER%2,4,8	N	2500	7.53	2500 * B
MC12095D	V LOWPOWPRESCLDIVBY2,4	N	96	7.48	96
MC12095DR2	V LOWPOWPRESCLDIVBY2,4	N	2500	7.53	2500 *
MC12095SD	V LOWPOWPRESCLDIVBY2,4	N	96	7.48	96 *
MC12100FN	V HIACCURHIFREQVCO	2	46	13.92	46 S
MC12101FN	V LASTORDERDATE:12/01/98	2	46	13.13	46 S
MC12147D	V 1.1GHZVCO	N	98	4.21	98 P
MC12148D	V VOLTCONTROLOSCILLATOR	2	98	4.26	98 P
MC12148P	V VOLTCONTROLOSCILLATOR	N	50	2.08	50 P
MC12148SD	V VOLTCONTROLOSCILLATOR	N	156	4.43	156 P
MC12149D	V 1.1GHZVCO	N	98	4.26	98 P
MC12179D	V FREQUENCYSYNTHESIZER	N	98	5.22	98 S P
MC12179DR2	V FREQUENCYSYNTHESIZER	2	2500	5.27	2500 S P
MC12181D	V 125-1000MHZFREQSYNTHZR	N	48	5.48	48 *
MC12202D	V SERINPUTFREQSYNTHSIZER	N	48	4.25	48
MC12202DT	V SERINPUTFREQSYNTHSIZER	N	75	4.75	75
MC12206D	V LASTORDERDATE:12/01/98	2	48	4.21	48
MC12206DT	V LASTORDERDATE:12/01/98	N	75	4.53	75 B
MC12210D	V SERIALINPUTFREQSNTHZER	2	48	7.33	48 P
MC12210DT	V SERIALINPUTFREQSNTHZER	N	75	5.42	75 B
MC12429FN	L CLOCKGENERATOR	N	37	21.90	37 B
MC12439FN	L CLOCKGENERATOR	N	37	21.90	37 B
MC13022ADWR3	J AMSTEREODECODER	2	1000	3.35	1000
MC13025D	J AMSTEREOPRONTEND	N	48	1.48	48 S
MC13025P	J AMSTEREOPRONTEND	2	25	1.48	500
MC13028AD	J AMSTEREODECODERIC	N	48	2.57	48
MC13028ADR2	J AMSTEREODECODERIC	2	2500	2.63	2500

A = OSPD/Power
 B = Analog/Logic
 J = Transportation
 L = Consumer
 N = Networking
 V = Wireless

S = Proprietary Device
 B = Motorola Blue Chip Program Device
 P = Phoenix Program
 * = First Time in Book
 † = \$200 Minimum Waived

N = Key New Motorola Device
 R = Key "Focus" Motorola Device

1 = Mature, Stable, High-Volume Device
 2 = Moderate-Volume Device
 3 = Low-Volume Device

COMMERCIAL COMPONENTS

Type No.	Grp/Description	Per Unit Sugg. Factory			Type No.	Grp/Description	Per Unit Sugg. Factory									
		PC	Qty	Price			Order	PC	Qty	Price	Order					
MC13028AP	J AMSTEREODECODER	N	25	2.57	25	MC13176DR2	V UHF TRANSMITTER	2	2500	3.82	2500	S	P			
MC13030DW	J DUAL CONV AMRECEIVER	N	26	3.54	26	MC1350D	V LIN IF AMP	1	98	1.44	98	S				
MC13030DWR3	J DUAL CONV AMRECEIVER	2	1000	2.93	1000	MC1350DR2	V LIN RF/IF AMP	2	2500	1.48	2500	S				
MC13055D	V LIN WIDEBAND FSK RCVR	2	48	3.47	48	S	P	MC1350P	V LIN IF AMP	1	50	1.44	1000	S		
MC13055DR2	V LIN WIDEBAND FSK RCVR	2	2500	3.51	2500	S	P	MC1357D	L LIN IF AMP & QUAD DETCTR	2	55	1.16	55			
MC13055P	V LIN WIDEBAND FSK RCVR	2	25	3.47	500	S	P	MC1357P	L LIN IF AMP & QUAD DETCTR	2	25	1.16	500			
MC13060D	L LIN MINI-WATT AUDIO OUTPT	3	98	2.21	98	S	P	MC1374P	L LIN TV MODULATOR CIRCUIT	1	25	1.84	500	S	P	
MC13060DR2	L LIN ONE WATT AUDIO AMP	2	2500	1.15	2500	S	P	MC1377DW	L LIN RGB COLOR ENCDR	2	38	3.46	38	S	P	
MC13077DW	L LIN ADV PAL/NTSC ENCODER	N	38	5.13	38	S	P	MC1377DWR2	L LIN RGB COLOR ENCDR	2	1000	3.49	1000	S	P	
MC13077DWR2	L LIN ADV PAL/NTSC ENCODER	N	1000	5.17	1000	★	S	P	MC1377P	L LIN RGB TO PAL/NTSC ENCDR	2	18	3.28	360	S	P
MC13077P	L LIN ADV PAL/NTSC ENCODER	2	18	4.95	360	S	P	MC1378FN	L LIN COLOR TV VIDEO SYNCH	2	26	13.12	26	S	P	
MC13081XB	L MONITOR CHIP	N	9	6.48	9	S	P	MC1378P	L LIN COLOR TV VIDEO SYNCH	2	9	13.12	9	S	P	
MC13109FB	V COMBO	N	96	12.15	96	S	P	MC1391P	L LIN TV HORIZ PROCESSOR	2	50	.67	1000			
MC13109FTA	V COMBO	N	250	6.32	1250	S	P	MC14C88BD	B QDLOPWR RS232/562 LNDR	N	55	1.13	55	†		
MC13110FB	V COMBO3 CT1 PHONE CIRCUIT	N	96	11.88	480	S	P	MC14C88BDR2	B QDLOPWR RS232/562 LNDR	N	2500	1.02	2500	†		
MC13110FBR2	V COMBO3 CT1 PHONE CIRCUIT	N	750	11.92	750	★	S	P	MC14C88BP	B QDLOPWR RS232/562 LNDR	2	25	.99	500	†	
MC13111FB	V COMBO4 CT1 PHONE CIRCUIT	N	96	8.91	480	S		MC14C89ABD	B QDLOPWR RS232/562 RECVR	2	55	1.37	55	†		
MC13122DW	J AMSTEREODECODER	N	26	3.70	26	S		MC14C89ABDR2	B QDLOPWR RS232/562 RECVR	2	2500	1.40	2500	†		
MC13122DWR3	J AMSTEREODECODER	2	1000	3.76	1000	S		MC14C89ABP	B QDLOPWR RS232/562 RECVR	2	25	1.19	500	†		
MC13122P	J AMSTEREODECODER	N	13	3.70	13			MC14C5003FU	L 128 SEGMENT LCD DRIVER	N	96	2.66	96	★		
MC13135DW	V VHF RECEIVER	N	30	3.51	30	S	P	MC14C5447DW	N COST REDUCED CALLIER I.D.	N	47	1.88	47			
MC13135DWR2	V VHF RECEIVER	N	1000	2.41	1000	★	S	P	MC14C5447DWR2	N CLASS DEMODULATOR	N	1000	1.94	1000		
MC13135P	V VHF RECEIVER	N	15	3.51	15	S	P	MC14C5447P	N COST REDUCED CALLIER I.D.	N	25	1.88	25			
MC13136DW	V IF RECEIVER	N	30	3.51	30	S	P	MC14C5472FE	N ISDN "U" TRANSCEIVER	2	180	45.22	180			
MC13136DWR2	V IF RECEIVER	N	1000	2.41	1000	★	S	P	MC14C5472FU	N ISDN "U" TRANSCEIVER	2	390	30.92	390		
MC13136P	V IF RECEIVER	N	15	3.33	15	S	P	MC14C5480DW	N PCM CODEC/FILTER	N	38	2.68	38	B		
MC13142D	V LOPWR DC-1.8GHZ LN AMIXER	N	48	3.87	48			MC14C5480DWR2	N PCM CODEC/FILTER	2	1000	2.73	1000	B		
MC13143D	V LOPWR DC-1.8GHZ MIXER	N	98	3.87	98			MC14C5480P	N PCM CODEC/FILTER	N	18	2.68	18	B		
MC13143DR2	V LOPWR DC-1.8GHZ MIXER	N	2500	3.91	2500	★		MC14C5480SD	N PCM CODEC/FILTER	N	66	2.95	66	B		
MC13144D	V PROGRMABLE LO-NOISE AMPL	N	98	1.89	98	★	S	MC14C5480SDR2	N PCM CODEC/FILTER	N	1500	3.00	1500	B		
MC13144DR2	V PROGRMABLE LO-NOISE AMPL	N	2500	1.94	2500	★	S	MC14C5540DW	N ADPCM/CODEC	N	26	6.38	26	B		
MC13150FTA	V NBFM RCVR W/COILSS DTCTR	N	576	5.59	2880	★	S	P	MC14C5540DWR2	N ADPCM/CODEC	2	1000	6.43	1000	B	
MC13150FTAR2	V NBFM RCVR W/COILSS DTCTR	N	2000	5.63	2000	★	S	P	MC14C5540FU	N ADPCM/CODEC	N	90	7.34	90	B	
MC13150FTB	V NARBND FMRX COILESS DET	N	250	4.26	1250	S	P	MC14C5540P	N ADPCM/CODEC	N	13	6.38	13	B		
MC13150FTBR2	V NARBND FMRX COILESS DET	N	1800	4.30	1800	★	S	P	MC14001BCL	B CMOS QUAD2-INOR GATE	2	25	1.13	500	†	
MC13155D	V WIDEBAND IF	2	48	4.28	48	S	P	MC14001BCP	B CMOS QUAD2-INOR GATE	1	25	.27	500	†		
MC13155DR2	V WIDEBAND IF	2	2500	4.32	2500	S	P	MC14001BD	B CMOS QUAD2-INOR GATE	2	55	.29	55	†		
MC13156DW	V FM IF RECEIVER	N	30	5.02	30	S	P	MC14001BDR2	B QUAD2-INPUT NOR GATE	2	2500	.31	2500	†		
MC13156DWR2	V FM IF RECEIVER	2	1000	5.02	1000	S	P	MC14001UBCP	B CMOS QUAD2-1 NOR GATE	2	25	.27	500	†		
MC13156FB	V FM IF SYSTEM	N	250	4.84	1250	S	P	MC14001UBD	B CMOS QUAD2-INOR GATE	2	55	.29	55	†		
MC13158FTB	V IF RECEIVER	N	250	6.13	1250	S	P	MC14001UBDR2	B CMOS QUAD2-INOR GATE	2	2500	.31	2500	†		
MC13158FTBR2	V IF RECEIVER	N	1800	5.17	1800	★	S	P	MC14002BCP	B CMOS DUAL4-INOR GATE	2	25	.27	500	†	
MC13173FTB	V IR TRANSCEIVER	N	90	10.22	450	S	P	MC14002BDR2	B DUAL4-INPUT NOR GATE	2	2500	.31	2500	†		
MC13175D	V UHF TRANSMITTER	N	48	3.78	48	S	P	MC14006BCP	B CMOS 18-BIT STATIC S/R	2	25	.63	500	†		
MC13176D	V UHF TRANSMITTER	1	48	3.78	48	S	P	MC14007UBCP	B CMOS DUAL COMP PAIR/INV	2	25	.27	500	†		

A = OSPD/Power
 B = Analog/Logic
 J = Transportation
 L = Consumer
 N = Networking
 V = Wireless

S = Proprietary Device
 B = Motorola Blue Chip Program Device
 P = Phoenix Program
 ★ = First Time in Book
 † \$200 Minimum Waived

N = Key New Motorola Device
 R = Key "Focus" Motorola Device

1 = Mature, Stable, High-Volume Device
 2 = Moderate-Volume Device
 3 = Low-Volume Device

EFFECTIVE DATE: JANUARY 10, 1998

COMMERCIAL COMPONENTS

Type No.	Grp/Description	Per Unit Sugg. Factory			†	
		Resale Price	Price	Order		
PC	Qty	Price	Incrrmnt			
MC14007UBD	B CMOS DUAL COMP PAIR/INV	2	55	.29	55	†
MC14007UBDR2	B DUAL COMPL PR PLU INV	2	2500	.31	2500	†
MC14008BCL	B CMOS4-BIT FULL ADDER	3	25	3.15	500	†
MC14008BCP	B CMOS4-BIT FULL ADDER	2	25	.63	500	†
MC14008BDR2	B 4-BIT FULL ADDER	2	2500	.67	2500	†
MC14011BCL	B CMOS QUAD2-I NAND GATE	2	25	1.13	500	†
MC14011BCP	B CMOS QUAD2-I NAND GATE	1	25	.27	500	†
MC14011BD	B CMOS QUAD2-I NAND GATE	1	55	.29	55	†
MC14011BDR2	B QUAD2-INPUT NAND GATE	2	2500	.31	2500	†
MC14011UBCP	B CMOS QUAD2-I NAND GATE	2	25	.27	500	†
MC14011UBD	B CMOS QUAD2-I NAND GATE	2	55	.29	55	†
MC14011UBDR2	B QUAD2-INPUT NAND GATE	2	2500	.31	2500	†
MC14012BCL	B CMOS DUAL4-1 NAND GATE	3	25	2.24	500	†
MC14012BCP	B CMOS DUAL4-1 NAND GATE	2	25	.27	500	†
MC14012BDR2	B DUAL4-INPUT NAND GATE	2	2500	.31	2500	†
MC14013BCL	B CMOS DUAL D-TYPE FF	1	25	1.17	500	†
MC14013BCP	B CMOS DUAL D-TYPE FF	1	25	.29	500	†
MC14013BD	B CMOS DUAL D-TYPE FF	1	55	.31	55	†
MC14013BDR2	B DUAL D FLIP-FLOP	2	2500	.32	2500	†
MC14014BCL	B CMOS8-BIT STATIC S/R	3	25	3.06	500	†
MC14014BCP	B CMOS8-BIT STATIC S/R	2	25	.68	500	†
MC14014BDR2	B 8-BIT STATIC SHFT REG	2	2500	.58	2500	†
MC14015BCL	B CMOS DUAL4-BIT STAT S/R	2	25	2.39	500	†
MC14015BCP	B CMOS DUAL4-BIT STAT S/R	1	25	.61	500	†
MC14015BD	B CMOS DUAL4-BIT STAT S/R	2	48	.63	48	†
MC14015BDR2	B DUAL5-BIT STATIC SFT REG	2	2500	.65	2500	†
MC14016BCL	B CMOS QUAD ANALOG SW/MUX	3	25	2.28	500	†
MC14016BCP	B CMOS QUAD ANALOG SW/MUX	1	25	.36	500	†
MC14016BD	B CMOS QUAD ANALOG SW/MUX	2	55	.38	55	†
MC14016BDR2	B QD ANALOG STCH/QD MULTIPL	2	2500	.40	2500	†
MC14017BCL	B CMOS DECADE CNTR/DIVIDER	2	25	2.39	500	†
MC14017BCP	B CMOS DECADE CNTR/DIVIDER	1	25	.61	500	†
MC14017BD	B CMOS DECADE CNTR/DIVIDER	2	48	.63	48	†
MC14017BDR2	B DECADE COUNTER/DIVIDER	2	2500	.65	2500	†
MC14018BCP	B CMOS PRESET DIV BY N CNTR	2	25	.68	500	†
MC14020BCL	B CMOS14-BIT BINARY CNTR	2	25	2.03	500	†
MC14020BCP	B CMOS14-BIT BINARY CNTR	1	25	.59	500	†
MC14020BD	B CMOS14-BIT BINARY CNTR	2	48	.61	48	†
MC14020BDR2	B 14-BIT BINARY COUNTER	2	2500	.63	2500	†
MC14021BCL	B CMOS8-BIT STATIC S/R	2	25	1.80	500	†
MC14021BCP	B CMOS8-BIT STATIC S/R	1	25	.59	500	†
MC14021BD	B CMOS8-BIT STATIC S/R	2	48	.61	48	†
MC14021BDR2	B 8-BIT STATIC SHFT REG	2	2500	.63	2500	†
MC14022BCP	B CMOS OCTAL CNTR/DIV	2	25	.59	500	†
MC14022BDR2	B OCTAL COUNTER/DIVIDER	2	2500	.63	2500	†

Type No.	Grp/Description	Per Unit Sugg. Factory			†	
		Resale Price	Price	Order		
PC	Qty	Price	Incrrmnt			
MC14023BCL	B CMOS TRIPLE3-I NAND GATE	2	25	1.13	500	†
MC14023BCP	B CMOS TRIPLE3-I NAND GATE	1	25	.27	500	†
MC14023BD	B CMOS TRIPLE3-I NAND GATE	2	55	.29	55	†
MC14023BDR2	B TRIPLE3-INPUT NAND GATE	2	2500	.31	2500	†
MC14024BCL	B CMOS7-STGRIPPLE CNTR	2	25	1.58	500	†
MC14024BCP	B CMOS7-STGRIPPLE CNTR	1	25	.43	500	†
MC14024BD	B CMOS7-STGRIPPLE CNTR	2	55	.45	55	†
MC14024BDR2	B 7-STAGE RIPPLE COUNTER	2	2500	.47	2500	†
MC14025BCP	B CMOS TRIPLE3-I NOR GATE	1	25	.27	500	†
MC14025BDR2	B TRIPLE3-INPUT NOR GATE	2	2500	.31	2500	†
MC14027BCL	B CMOS DUAL J-K FF	2	25	1.55	500	†
MC14027BCP	B CMOS DUAL J-K FF	1	25	.32	500	†
MC14027BD	B CMOS DUAL J-K FF	2	48	.34	48	†
MC14027BDR2	B DUAL J-K FLIP-FLOP	2	2500	.36	2500	†
MC14028BCL	B CMOS BCD-TO-DECIMAL DEC	3	25	3.38	500	†
MC14028BCP	B CMOS BCD-TO-DECIMAL DEC	1	25	.59	500	†
MC14028BD	B CMOS BCD-TO-DECIMAL DEC	2	48	.61	48	†
MC14028BDR2	B BCD TO DECIMAL DECODER	2	2500	.63	2500	†
MC14029BCP	B CMOS BIN/DEC U/D CTR	2	25	.59	500	†
MC1403BD	B VOLT REG	2	98	1.80	98	†
MC1403BDR2	B VOLT REG	N	2500	1.83	2500 *	†
MC1403BP1	B LIN LOW VOLT REF NCE	N	50	2.00	1000 *	†
MC1403D	B LIN PREC LOW VOLT REFR NCE	1	98	1.50	98	†
MC1403DR2	B PREC LO VOLT REF	2	2500	1.53	2500	†
MC1403P1	B LIN LOW VOLT REF NCE	N	50	1.94	1000	†
MC14035BCP	B CMOS4-BIT S/R	2	25	.65	500	†
MC1404P5	B PRECISION VOLT REGULATOR	N	50	.87	1000	†
MC14040BCL	B CMOS12-BIT BINARY CNT	2	25	1.98	500	†
MC14040BCP	B CMOS12-BIT BINARY CNT	1	25	.59	500	†
MC14040BD	B CMOS12-BIT BINARY CNT	2	48	.61	48	†
MC14040BDR2	B 12 BIT BINARY COUNTER	2	2500	.63	2500	†
MC14042BCL	B CMOS QUAD LATCH	3	25	3.17	500	†
MC14042BCP	B CMOS QUAD LATCH	2	25	.45	500	†
MC14042BDR2	B QUAD LATCH	2	2500	.49	2500	†
MC14043BCL	B CMOS QUAD NOR R-S LATCH	2	25	2.03	500	†
MC14043BCP	B CMOS QUAD NOR R-S LATCH	1	25	.59	500	†
MC14043BD	B CMOS QUAD NOR R-S LATCH	2	48	.61	48	†
MC14043BDR2	B QUAD NOR R-S LATCH	2	2500	.63	2500	†
MC14044BCP	B CMOS QUAD NAND R-S LATCH	2	25	.59	500	†
MC14044BDR2	B QUAD NOR R-S LATCH	2	2500	.63	2500	†
MC14046BCL	B CMOS PHASE-LOCKED LOOP	2	25	2.25	500	†
MC14046BCP	B CMOS PHASE-LOCKED LOOP	1	25	.68	500	†
MC14046BDW	B PHASE LOCKED LOOP	2	47	.70	47	†
MC14046BDR2	B PHASE LOCKED LOOP	2	1000	.72	1000	†
MC14049BCP	B HEX INVERT/BUFFER	1	25	.32	500	†

A = OSPD/Power
 B = Analog/Logic
 J = Transportation
 L = Consumer
 N = Networking
 V = Wireless

S = Proprietary Device
 B = Motorola Blue Chip Program Device
 P = Phoenix Program
 * = First Time in Book
 † \$200 Minimum Waived

N = Key New Motorola Device
 R = Key "Focus" Motorola Device

1 = Mature, Stable, High-Volume Device
 2 = Moderate-Volume Device
 3 = Low-Volume Device

COMMERCIAL COMPONENTS

Type No.	Grp/Description	PC	Unit Qty	Sugg. Resale Price	Factory Order	Incrrmt	Type No.	Grp/Description	PC	Unit Qty	Sugg. Resale Price	Factory Order	Incrrmt
MC14049BD	B HEXINVERTER/BUFFER	2	48	.34	48	†	MC14071BCL	B CMOSQUAD2-IORGATE	2	25	1.13	500	†
MC14049BDR2	B HEXINVERTER/BUFFER	2	2500	.36	2500	†	MC14071BCP	B CMOSQUAD2-IORGATE	1	25	.27	500	†
MC14049UBCL	B CMOSHEXINVERTINGBUFFER	1	25	1.46	500	†	MC14071BD	B CMOSQUAD2-IORGATE	2	55	.29	55	†
MC14049UBCP	B CMOSHEXINVERTINGBUFFER	1	25	.32	500	†	MC14071BDR2	B QUAD2-INPUT OR GATE	2	2500	.31	2500	†
MC14049UBD	B CMOSHEXINVERTINGBUFFER	2	48	.34	48	†	MC14072BCP	B CMOSDUAL4-IORGATE	2	25	.27	500	†
MC14049UBDR2	B HEXINVERTER/BUFFER	2	2500	.36	2500	†	MC14073BCL	B CMOSTRIPLE3-IANDGATE	3	25	2.21	500	†
MC14050BCL	B CMOSHEXNON-INVBUFFER	2	25	1.39	500	†	MC14073BCP	B CMOSTRIPLE3-IANDGATE	1	25	.27	500	†
MC14050BCP	B CMOSHEXNON-INVBUFFER	1	25	.36	500	†	MC14073BDR2	B TRIPLE3-INPUT OR GATE	2	2500	.31	2500	†
MC14050BD	B CMOSHEXNON-INVBUFFER	2	48	.38	48	†	MC14075BCL	B CMOSTRIPLE3-IORGATE	3	25	1.60	500	†
MC14050BDR2	B HEXBUFFER	2	2500	.40	2500	†	MC14075BCP	B CMOSTRIPLE3-IORGATE	1	25	.27	500	†
MC14051BCL	B CMOS8-CHANNELMUX	2	25	1.58	500	†	MC14075BDR2	B TRIPLE3-INPUT OR GATE	2	2500	.31	2500	†
MC14051BCP	B CMOS8-CHANNELMUX	1	25	.50	500	†	MC14076BCP	B CMOSQUADD REGISTER	2	25	.63	500	†
MC14051BD	B CMOS8-CHANNELMUX	1	48	.52	48	†	MC14077BCP	B CMOSQUADEX-NORGATE	1	25	.27	500	†
MC14051BDR2	B 8-CHANNEL ANALOG MULTIPLEX	1	2500	.54	2500	†	MC14077BDR2	B QUAD EXCLUSIVE NOR GATE	2	2500	.31	2500	†
MC14051BDT	B CMOS8-CHANNELMUX	N	96	.86	96	†	MC14078BCP	B CMOS8-INOR GATE	2	25	.27	500	†
MC14052BCL	B CMOSDUAL4-CHANNELMUX	2	25	1.89	500	†	MC14078BDR2	B 8-INPUT NOR GATE	2	2500	.31	2500	†
MC14052BCP	B CMOSDUAL4-CHANNELMUX	1	25	.50	500	†	MC14081BCL	B CMOSQUAD2-IAND GATE	2	25	1.13	500	†
MC14052BD	B CMOSDUAL4-CHANNELMUX	1	48	.52	48	†	MC14081BCP	B CMOSQUAD2-IAND GATE	1	25	.27	500	†
MC14052BDR2	B DUAL4-CHL ANALOG MULTIPLX	2	2500	.52	2500	†	MC14081BD	B CMOSQUAD2-IAND GATE	2	55	.29	55	†
MC14053BCL	B CMOSTRIPLE2-CHANNELMUX	2	25	1.80	500	†	MC14081BDR2	B QUAD2-INPUT AND GATE	2	2500	.31	2500	†
MC14053BCP	B CMOSTRIPLE2-CHANNELMUX	1	25	.50	500	†	MC14082BCL	B CMOSDUAL4-IAND GATE	3	25	2.21	500	†
MC14053BD	B CMOSTRIPLE2-CHANNELMUX	1	48	.52	48	†	MC14082BCP	B CMOSDUAL4-IAND GATE	2	25	.27	500	†
MC14053BDR2	B TRIPLE2-CHLANLOGMULTIP	2	2500	.54	2500	†	MC14093BCL	B CMOSQUAD2-I NAND S.T.	2	25	1.13	500	†
MC14060BCL	B CMOS14-STGBINCTR/OSC	2	25	2.39	500	†	MC14093BCP	B CMOSQUAD2-I NAND S.T.	1	25	.34	500	†
MC14060BCP	B CMOS14-STGBINCTR/OSC	1	25	.58	500	†	MC14093BD	B CMOSQUAD2-I NAND S.T.	1	55	.36	55	†
MC14060BD	B CMOS14-STGBINCTR/OSC	1	48	.61	48	†	MC14093BDR2	B QUAD2-I NAND SCHMT TRIGR	2	2500	.38	2500	†
MC14060BDR2	B 14-BIT BINCOUNT & OSCIL	2	2500	.61	2500	†	MC14094BCL	B CMOS8-BIT SHIFT/ST REG.	3	25	3.15	500	†
MC14066BCL	B CMOSQUADANALOG SWITCH	2	25	1.15	500	†	MC14094BCP	B CMOS8-BIT SHIFT/ST REG.	1	25	.54	500	†
MC14066BCP	B CMOSQUADANALOG SWITCH	1	25	.36	500	†	MC14094BD	B CMOS8-BIT SHIFT/ST REG.	2	48	.56	48	†
MC14066BD	B CMOSQUADANALOG SWITCH	1	55	.38	55	†	MC14094BDR2	B 8-BIT COMPT SHT STORE LAT	2	2500	.58	2500	†
MC14066BDR2	B CMOSQUADANALOG SWITCH	2	2500	.40	2500	†	MC14099BCP	B CMOS8-BIT ADDRESS LATCH	2	25	.68	500	†
MC14066BDT	B CMOSQUADANALOG SWITCH	N	96	.72	96	†	MC14099BDW	B CMOS8-BIT ADDRESS LATCH	2	47	.72	47	†
MC14067BCP	B CMOS16-CHANALOGMUX/DEM	1	15	1.71	15	†	MC14099BDWR2	B 8-BIT ADDRESSBL LATCH	2	1000	.76	1000	†
MC14067BDWR2	B ANALOGMULTIPLEX/DEMULPL	2	1000	1.76	1000	†	MC14106BCL	B CMOSHEX SCHMITT TRIGGER	3	25	2.31	500	†
MC14068BCP	B CMOS8-INAND GATE	2	25	.27	500	†	MC14106BCP	B CMOSHEX SCHMITT TRIGGER	1	25	.36	500	†
MC14069UBCL	B CMOSHEXINVERTER	2	25	1.13	500	†	MC14106BD	B CMOSHEX SCHMITT TRIGGER	2	55	.38	55	†
MC14069UBCP	B CMOSHEXINVERTER	1	25	.27	500	†	MC14106BDR2	B HEXSCHMIDT TRIGGER	2	2500	.40	2500	†
MC14069UBD	B CMOSHEXINVERTER	2	55	.29	55	†	MC1413BD	B LIN PER DRVR ARRAY	2	48	.88	48	†
MC14069UBDR2	B HEXINVERTER	2	2500	.31	2500	†	MC1413BDR2	B LIN PER DRVR ARRAY	N	2500	.92	2500 *	†
MC14069UBDT	B CMOSHEXINVERTER	N	96	.63	96	†	MC1413BP	B LIN PER DRVR ARRAY	2	25	.77	500	†
MC14069UBDR2	B CMOSHEXINVERTER	N	2500	.63	2500	†	MC1413D	B LIN PERIPHERAL DRVR ARRAY	1	48	.70	48	†
MC14070BCL	B CMOSQUADEX-ORGATE	2	25	1.13	500	†	MC1413DR2	B PERIPHERAL DRVR ARRAY	1	2500	.73	2500	†
MC14070BCP	B CMOSQUADEX-ORGATE	1	25	.27	500	†	MC1413P	B LIN PERIPHERAL DRVR ARRAY	1	25	.61	500	†
MC14070BD	B CMOSQUADEX-ORGATE	2	55	.29	55	†	MC141540P4	L MONITOR ON SCREEN DISPLAY	N	25	2.66	25	
MC14070BDR2	B QUAD EXCLUSIVE OR GATE	2	2500	.31	2500	†	MC141541P	L MONITOR ON SCREEN DISPLAY	N	25	2.46	25	S

A = OSPD/Power
 B = Analog/Logic
 J = Transportation
 L = Consumer
 N = Networking
 V = Wireless

S = Proprietary Device
 B = Motorola Blue Chip Program Device
 P = Phoenix Program
 * = First Time in Book
 † \$200 Minimum Waived

N = Key New Motorola Device
 R = Key "Focus" Motorola Device

1 = Mature, Stable, High-Volume Device
 2 = Moderate-Volume Device
 3 = Low-Volume Device

EFFECTIVE DATE: JANUARY 10, 1998

COMMERCIAL COMPONENTS

Type No.	Grp/Description	PC	Qty	Per Unit Sugg.	Factory	Order	Incrmnt
				Resale Price			
MC141543P	L MONITOR ON SCREEN DISPLAY	N	25	2.46	25		
MC1416BD	B LIN PER DRVR ARRAY	2	48	.88	48	†	
MC1416BDR2	B LIN PER DRVR ARRAY	N	2500	.92	2500	★	†
MC1416BP	B LIN PER DRVR ARRAY	2	25	.77	500		†
MC1416D	B LIN PERIPHERAL DRVR ARRAY	N	48	.70	48		†
MC1416DR2	B LIN PERIPHERAL DRVR ARRAY	N	2500	.73	2500		†
MC1416P	B LIN PERIPHERAL DRVR ARRAY	1	25	.61	500		†
MC14161BCP	B CMOS4BIT BINARY CNTR	2	25	.61	500		†
MC141622AFT	L 2H COMB FILTER-NITSC	N	50	9.31	50		
MC141624FU	L 1H COMB FILTER	N	90	3.99	90		
MC141627FT	L ADVNCD PAL COMB FLTR-II	N	50	10.08	50		
MC14174BCL	B CMOS HEXD-FF	2	25	2.16	500		†
MC14174BCP	B CMOS HEXD-FF	2	25	.54	500		†
MC14174BDR2	B HEXD FLIP-FLOP	2	2500	.58	2500		†
MC14175BCL	B CMOS QUADD-TYPE FF	3	25	3.03	500		†
MC14175BCP	B CMOS QUADD-TYPE FF	2	25	.54	500		†
MC14175BDR2	B QUADD FLIP-FLOP	2	2500	.58	2500		†
MC143120B1DW	N NEURONIC	1	22	6.41	22	B	
MC143120E2DW	N NEURON DIST. CONTROLLER	N	22	7.66	22	★	B
MC143150B1FU1	N NEURON-EXTERNAL MEMORY	N	250	6.25	250		B
MC1436CDR2	B HIVOLT OP AMP	N	2500	.87	2500	★	†
MC1436CP1	B LIN HIVOLT/INT COMPO.A.	2	50	.64	1000		†
MC1436D	B LIN HIVOLT/INT COMPO.A.	3	98	1.84	98		†
MC1436DR2	B HIVOLT OP AMP	N	2500	1.03	2500	★	†
MC1436P1	B LIN HIVOLT/INT COMPO.A.	2	50	.67	1000		†
MC144111DW	V CMOS QUADD/A CONV6 BIT	2	47	3.81	47	S P	
MC144111P	V CMOS QUADD/A CONV6 BIT	2	25	3.81	25	S P	
MC144112D	V QUAD6-BIT D/A CONVERTER	N	55	2.58	55	★	S P
MC14447DW	V DATA CONVERTER	N	47	6.99	47	★	
MC14447P	V CMOS8-BIT A/D SUBSYSTEM	2	25	6.99	25		
MC14467P1	J CMOS SMOKE DETECTOR, ION	2	25	1.02	25		
MC14468P	J CMOS SMOKE DETECTOR, ION	N	25	1.09	25		
MC14469P	N CMOS ASYN RECEIVER/TRANS	1	9	3.99	9		
MC14489DW	L LED DISPLAY/LAMP DRIVER	1	38	2.26	38		
MC14489P	L LED DISPLAY/LAMP DRIVER	1	18	2.26	18		
MC14490DW	B CMOS HEXBOUNCE ELIMINAT	1	47	4.32	47	S	†
MC14490L	B CMOS HEXBOUNCE ELIMINAT	2	25	6.80	500	S	†
MC14490P	B CMOS HEXBOUNCE ELIMINAT	1	25	4.32	25	S	†
MC14495P1	L CMOS HEX TO7-SEG DRIVER	1	25	1.93	25		
MC14499P	L LAST ORDER DATE:03/04/98	1	20	2.26	20		
MC14500BCP	B CMOS1-BIT ICU	2	25	6.18	500	S P	†
MC145000FN	L CMOS LCD DISP DVR MASTER	2	37	4.52	37		
MC145000P	L CMOS LCD DISP DVR MASTER	2	15	3.86	15		
MC145001FN	L CMOS LCD DISP DVR SLAVE	2	37	3.84	37		
MC145001P	L CMOS LCD DISP DVR SLAVE	2	20	3.26	20		

Type No.	Grp/Description	PC	Qty	Per Unit Sugg.	Factory	Order	Incrmnt
				Resale Price			
MC145010DW	J SMOKE DET, PHOTO WITH I/O	N	47	1.89	47		
MC145010DWR2	J SMOKE DET, PHOTO WITH I/O	N	1000	1.96	1000	★	
MC145010P	J SMOKE DET, PHOTO WITH I/O	2	25	1.89	25		
MC145012DW	J PHOTO SMKE DET/NFPATONE	N	47	1.89	47		
MC145012P	J PHOTO SMKE DET/NFPATONE	N	25	1.89	25		
MC14502BCP	B CMOS STROBE HEX INV/BUFFR	2	25	.63	500		†
MC145026D	V CMOS REMOTE CONT ENCODER	1	48	1.51	48		
MC145026P	V CMOS REMOTE CONT ENCODER	1	25	1.51	25		
MC145027DW	V CMOS REMOTE CONT DECODER	2	47	2.15	47		
MC145027P	V CMOS REMOTE CONT DECODER	2	25	2.15	25		
MC145028P	V CMOS REMOTE CONT DECODER	2	25	2.15	25		
MC14503BCL	B CMOS HEX3-STATE BUFFER	2	25	2.16	500		†
MC14503BCP	B CMOS HEX3-STATE BUFFER	1	25	.52	500		†
MC14503BD	B CMOS HEX3-STATE BUFFER	2	48	.45	48		†
MC14503BDR2	B HEX3-STATE BUFFER	2	2500	.49	2500		†
MC14504BCL	B CMOS HEX LEVEL SHIFTER	2	25	2.27	500		†
MC14504BCP	B CMOS HEX LEVEL SHIFTER	1	25	1.17	500		†
MC14504BD	B CMOS HEX LEVEL SHIFTER	2	48	1.17	48	S P	†
MC14504BDR2	B HXTTL/CMOS-CMOS LEVLSHF	2	2500	1.20	2500	S P	†
MC145040DW	V CMOS8BIT A/D SERL INTERF	N	38	3.76	38		
MC145040DWR2	V CMOS8BIT A/D SERL INTERF	N	1000	3.76	1000	★	
MC145040P	V CMOS8-BIT A/D SERIAL INT	2	18	3.76	18		
MC145041DW	V CMOS8BIT A/D SERL INTERF	1	38	3.76	38		
MC145041DWR2	V CMOS8BIT A/D SERL INTERF	2	1000	3.76	1000		
MC145041P	V CMOS8-BIT A/D SERIAL INT	1	18	3.76	18		
MC145050DW	V 10-BIT A/D CONV W/SERIAL	N	38	3.27	38		
MC145050DWR2	V 10-BIT A/D CONV W/SERIAL	N	1000	3.27	1000	★	
MC145050P	V 10-BIT A/D CONV W/SERIAL	2	18	3.27	18		
MC145051DT	V 10-BIT11 CHANNEL SPI	N	66	3.87	66	★	
MC145051DW	V 10-BIT11 CHANNEL SPI	1	38	3.27	38		
MC145051DWR2	V 10-BIT11 CHANNEL SPI	N	1000	3.27	1000	★	
MC145051P	V 10-BIT11 CHANNEL SPI	1	18	3.27	18		
MC145053D	V 10-BIT5 CHANA/D	2	55	3.10	55		
MC145053DR2	V 10-BIT5 CHANA/D	N	2500	3.10	2500	★	
MC145053P	V 10-BIT5 CHANA/D	2	25	3.10	25		
MC14508BCL	B CMOS DUAL4-BIT LATCH	3	15	6.73	15		†
MC14508BCP	B CMOS DUAL4-BIT LATCH	2	15	1.76	15		†
MC14510BCP	B CMOS BCD U/D CTNR	2	25	.70	500		†
MC145106DW	V FREQ SYSN PHASE LOCK LOOP	2	38	3.76	38	S P	
MC145106P	V CMOS PLL FREQ SYNTHESIZER	2	20	3.76	20	S P	
MC14511BCL	B CMOS BCD TO7SEGL/DEC/DR	3	25	3.18	500		†
MC14511BCP	B CMOS BCD TO7SEGL/DEC/DR	1	25	.68	500		†
MC14511BDWR2	B BCD TO7SEGLTCH/DEC/DRI	2	1000	.76	1000		†
MC14512BCL	B CMOS8-CH DATA SELECT	3	25	3.06	500		†
MC14512BCP	B CMOS8-CH DATA SELECT	1	25	.63	500		†

A = OSPD/Power
 B = Analog/Logic
 J = Transportation
 L = Consumer
 N = Networking
 V = Wireless

S = Proprietary Device
 B = Motorola Blue Chip Program Device
 P = Phoenix Program
 ★ = First Time in Book
 † \$200 Minimum Waived

N = Key New Motorola Device
 R = Key "Focus" Motorola Device

1 = Mature, Stable, High-Volume Device
 2 = Moderate-Volume Device
 3 = Low-Volume Device

EFFECTIVE DATE: JANUARY 10, 1998

COMMERCIAL COMPONENTS

Type No.	Grp/Description	Per PC	Unit Qty	Sugg. Price	Factory Order Incrrmt		Type No.	Grp/Description	Per PC	Unit Qty	Sugg. Price	Factory Order Incrrmt	
MC14512BDR2	B 8-CHANNEL DATA SELECTOR	2	2500	.67	2500	†	MC14519BCP	B CMOS4-BIT AND/OR SELECT	2	25	.45	500	†
MC14513BCP	B CMOS BCD TO 7-SEG DRIVER	2	20	2.03	20	S P †	MC14519BDR2	B 4-BIT AND/OR SELECTOR	2	2500	.49	2500	†
MC14514BCP	B CMOS4-BIT LATCH/DECODER	1	15	1.22	15	†	MC145190DT	V 1.1GHZ PLL FREQ SYNTH	N	75	3.60	75	S P
MC145145P2	V CMOS4BIT PLL FREQ SYNTH	N	20	6.02	20	S P	MC145190EVK	V R1GHZ PLL FREQSYNEVK	N	1	360.00	1	★
MC145146P2	V PLL FREQ SYNTH INPUT	N	18	6.13	18	S P	MC145190F	V 1.1GHZ PLL FREQ SYNTH	N	40	3.60	40	S P
MC145149P	V SERIAL INPUT DUAL PLL	N	18	9.35	18	S P	MC145190FR2	V 1.1GHZ PLL	2	1000	3.69	1000	S P
MC14515BCP	B CMOS4-BIT LATCH/DECODER	2	15	1.22	15	†	MC145191DT	V 1.1GHZ PLL FREQ SYNTH	N	75	3.60	75	S P
MC145151DW2	V CMOS FREQ SYNTH PARALLEL	1	26	6.45	26		MC145191EVK	V PLLEVAL BOARD	N	1	430.00	1	
MC145151DW2R2	V CMOS FREQ SYNTH PARALLEL	N	1000	6.45	1000	★	MC145191F	V 1.1GHZ PLL FREQ SYNTH	1	40	3.60	40	S P
MC145151P2	V CMOS FREQ SYNTH PARALLEL	1	13	6.45	13		MC145191FR2	V 1.1GHZ PLL	2	1000	3.69	1000	S P
MC145152DW2	V CMOS FREQ SYNTH PARALLEL	1	26	8.39	26		MC145192DT	V 1.1GHZ PLL FREQ SYNTH	N	75	3.60	75	S P
MC145152P2	V CMOS FREQ SYNTH PARALLEL	1	13	8.39	13		MC145192DTR2	V 1.1GHZ PLL FREQ SYNTH	N	2500	3.60	2500	★ S P
MC145155DW2	V CMOS FREQ SYNTH SERIAL	N	38	5.05	38		MC145192F	V 1.1GHZ PLL FREQ SYNTH	N	40	3.60	40	S P
MC145155P2	V CMOS FREQ SYNTH SERIAL	1	20	4.52	20		MC145192FR2	V 1.1GHZ PLL	2	1000	3.69	1000	S P
MC145156DW2	V CMOS FREQ SYNTH SERIAL	2	38	5.05	38		MC14520BCL	B CMOS DUAL BINARY UP CNTR	2	25	2.43	500	†
MC145156P2	V CMOS FREQ SYNTH SERIAL	2	18	5.05	18		MC14520BCP	B CMOS DUAL BINARY UP CNTR	1	25	.63	500	†
MC145157DW2	V CMOS FREQ SYNTH SERIAL	2	47	5.16	47		MC14520BDWR2	B DUAL BINARY UP COUNTER	2	1000	.67	1000	†
MC145157DW2R2	V CMOS FREQ SYNTH SERIAL	2	1000	5.20	1000		MC145200DT	V 2.0GHZ PLL	N	75	5.56	75	S P
MC145157P2	V CMOS FREQ SYNTH SERIAL	1	25	5.16	25		MC145200EVK	V R3GHZ PLL FREQSYNEVK	N	1	504.00	1	★
MC145158DW2	V CMOS FREQ SYNTH SERIAL	1	47	5.16	47		MC145200F	V 2GHZ PLL FREQ SYNTH	N	40	5.56	40	S P
MC145158DW2R2	V FREQ SYNTH SER INPUT PLL	2	1000	5.20	1000		MC145201DT	V 2.0GHZ PLL	N	75	5.56	75	S P
MC145158P2	V CMOS FREQ SYNTH SERIAL	2	25	5.16	25		MC145201EVK	V 2.0GHZ PLL FREQSYNEVK	N	1	504.00	1	★
MC145159DW1	V CMOS PLL FREQ SYN SERIAL	2	38	9.89	38	S P	MC145201F	V 2GHZ PLL FREQ SYNTH	N	40	5.56	40	S P
MC14516BCL	B CMOS BINARY U/D CNTR	2	25	2.34	500	†	MC145202DT	V 2CHIP/2.0GHZ PLL	N	75	6.97	75	S P
MC14516BCP	B CMOS BINARY U/D CNTR	1	25	.59	500	†	MC145202DTR2	V 2CHIP/2GHZ PLL	N	2500	7.01	2500	★ S P
MC14516BDR2	B CMOS BINARY U/D CNTR	2	2500	.61	2500	†	MC145202F	V 2.0GHZ PLL-3V	N	38	5.83	38	S P
MC145162D	V UNIVERSAL DUAL PHASE	N	48	2.26	48	S P	MC14521BCL	B CMOS24-STG FREQ DIVIDER	3	25	3.39	500	†
MC145162D1	V UDPLL	N	48	2.60	48	S P	MC14521BCP	B CMOS24-STG FREQ DIVIDER	1	25	.61	500	†
MC145162P	V UNIVERSAL DUAL PHASE	N	25	2.26	500	S P	MC14521BD	B CMOS24-STG FREQ DIVIDER	2	48	.61	48	†
MC145163P	V BCD INPT FREQ SYNTHESIZER	N	13	8.06	13	S P	MC14521BDR2	B 24-STAGE FREQUENCY DIVIDE	2	2500	.63	2500	†
MC145165P	V PROGRAMMABLE DPLL	N	25	4.09	500	S P	MC14522BCP	B CMOS PROG. BCD DOWN CNTR	2	25	.86	500	†
MC145166P	V CMOS DUAL LOOP PLL BCD	N	25	3.74	500	S P	MC145220DT	V DUAL1.1GHZ PLL FREQ SYN	N	75	3.33	75	S P
MC145167P	V CMOS DUAL LOOP PLL SERIAL	N	25	1.61	500	S P	MC145220F	V DUAL1.1GHZ PLL FREQ SYNT	N	40	3.60	40	S P
MC145168P	V LAST ORDER DATE:12/01/98	N	25	3.12	500	S P	MC14526BCL	B CMOS PROG4-BIT BIN CTR	3	25	3.33	500	†
MC14517BCP	B CMOS DUAL 64-BIT STAT S/R	2	25	1.31	500	†	MC14526BCP	B CMOS PROG4-BIT BIN CTR	2	25	.81	500	†
MC14517BDW	B CMOS DUAL 64-BIT STAT S/R	2	47	1.33	47	†	MC14527BCP	B CMOS BCD RATE MULT	2	25	.72	500	†
MC145170DT1	V 185MHZ PLL	N	96	3.31	96	S P	MC14528BCL	B CMOS DUAL MONO MULTIVIB	2	25	1.87	500	†
MC145170DT1R2	V 185MHZ PLL	2	2500	4.06	2500		MC14528BCP	B CMOS DUAL MONO MULTIVIB	1	25	.72	500	†
MC145170D1	V 185MHZ PLL	N	48	3.66	48		MC14528BDR2	B DUAL MONOSTABLE MULTIVIBR	2	2500	.74	2500	†
MC145170D1R2	V 185MHZ PLL	2	2500	3.76	2500		MC14529BCP	B CMOS DUAL4-CH DATA SELEC	2	25	.99	500	†
MC145170P1	V 185MHZ PLL	N	25	3.06	25	S P	MC14529BD	B CMOS DUAL4-CH DATA SELEC	2	48	1.01	48	†
MC145173DW	J AM/FM FREQ SYNTH	N	30	2.93	30		MC14531BDR2	B 12-BIT PARITY TREE	2	2500	.92	2500	†
MC14518BCL	B CMOS DUAL BCD UP CNTR	2	25	2.39	500	†	MC14532BCP	B CMOS 8 BIT PRIORITY ENC	2	25	.72	500	†
MC14518BCP	B CMOS DUAL BCD UP CNTR	1	25	.68	500	†	MC14532BDR2	B 8-BIT PRIORITY ENCODER	2	2500	.76	2500	†
MC14518BDWR2	B DUAL BCD UP COUNTER	2	1000	.72	1000	†	MC14536BCL	B CMOS PROGRAMMABLE TIMER	2	25	2.79	500	†

A = OSPD/Power
B = Analog/Logic
J = Transportation
L = Consumer
N = Networking
V = Wireless

S = Proprietary Device
B = Motorola Blue Chip Program Device
P = Phoenix Program
★ = First Time in Book
† \$200 Minimum Waived

N = Key New Motorola Device
R = Key "Focus" Motorola Device

1 = Mature, Stable, High-Volume Device
2 = Moderate-Volume Device
3 = Low-Volume Device

EFFECTIVE DATE: JANUARY 10, 1998

COMMERCIAL COMPONENTS

Type No.	Grp/Description	Per Unit Sugg.		Factory Order	Incrmnt	
		Resale Price	Price			
MC14536BCP	B CMOS PROGRAMMABLE TIMER	1	25	1.15	500	†
MC14536BDW	B CMOS PROGRAMMABLE TIMER	2	47	1.17	47	†
MC14536BDR2	B PROGRAMMABLE COUNTER	2	1000	1.19	1000	†
MC14538BCL	B CMOS DUAL MONOMULTIVIB	1	25	1.85	500	†
MC14538BCP	B CMOS DUAL MONOMULTIVIB	1	25	.81	500	†
MC14538BD	B DUAL PRECISION MONOSTABLE	1	48	.83	48	†
MC14538BDR2	B DUAL PRECISION MONOSTABLE	2	2500	.85	2500	†
MC14538BDW	B CMOS DUAL MONOMULTIVIB	1	47	.83	47	†
MC14538BDR2	B DUAL PRECISION MONOSTABLE	2	1000	.85	1000	†
MC14539BCP	B CMOS DUAL 4-CH DATA SEL	2	25	.72	500	S †
MC14539BDR2	B DUAL 4-CHN DATA SEL/MULTI	2	2500	.76	2500	S †
MC145403DW	N 3X5RS232 DRIVER/RECEIVER	2	38	1.53	38	
MC145403P	N 3X5RS232 DRIVER/RECEIVER	2	18	1.53	18	
MC145404DW	N 4X4RS232 DRIVER/RECEIVER	2	38	1.53	38	
MC145404P	N 4X4RS232 DRIVER/RECEIVER	2	18	1.53	18	
MC145406DW	N RS232 DRIVER/RECEIVER	1	47	1.13	47	
MC145406DWR2	N RS-232-C DRIVERS/RECEIVER	1	1000	1.20	1000	
MC145406P	N RS-232 DRIVER/RECEIVER	1	25	1.13	25	
MC145406SD	N 3.3RS232 TRANSCEIVER	N	77	1.25	77	
MC145407DW	N RS232 DRVR/RCVR, 5V ONLY	1	38	2.06	38	
MC145407DWR2	N RS232 DRVR/REC 5V ONLY	2	1000	2.13	1000	
MC145407P	N RS232, DRVR/RCVR, 5V ONLY	1	18	2.06	18	
MC145408DW	N 5X3TS232 DRIVER/RECEIVER	2	30	1.69	30	
MC14541BCL	B CMOS PROG. OSC-TIMER	3	25	2.42	500	†
MC14541BCP	B CMOS PROG. OSC-TIMER	1	25	.52	500	†
MC14541BD	B CMOS PROG. OSC-TIMER	2	55	.52	55	†
MC14541BDR2	B PROGRAMMABLE OSCIL-TIMER	2	2500	.56	2500	†
MC145421DW	N 160KBPS UDLT2	N	30	9.06	30	
MC145421P	N 160KBPS UDLT2	N	15	9.06	15	
MC145422DW	N UNIV DIGT-LOOP TRANSCEIVER	N	30	8.23	30	
MC145422P	N 80KBPS UDLT1 MASTER	1	15	8.23	15	
MC145425DW	N 160KBPS UDLT2	N	30	9.06	30	
MC145425P	N 160KBPS UDLT2	N	15	9.06	15	
MC145426DW	N UNIV DIGT-LOOP TRANSCEIVER	N	30	8.23	30	
MC145426P	N 80KBPS UDLT1 SLAVE	N	15	8.23	15	
MC14543BCP	B CMOS BCD-TO-7SEGL/DE/DRV	1	25	.61	500	†
MC14543BD	B CMOS BCD-TO-7SEGL/DE/DRV	2	48	.63	48	†
MC14543BDR2	B BCD-TO-7SEGLTH/DEC/DRI	2	2500	.65	2500	†
MC145436ADW	N DTMF RECEIVER	1	47	1.60	47	
MC145436AP	N DTMF RECEIVER	1	25	1.60	25	
MC145442DW	N SINGLE CHIP 300BAUD MODEM	2	38	3.76	38	
MC145442P	N SNGL CHP 300BAUD MODEM	2	18	3.76	18	
MC145443ADW	N MODEMBELL103	1	38	3.76	38	
MC145443P	N SNGL CHP 300BAUD MODEM	1	18	3.76	18	
MC145444DW	N GASTELEMETER MODEM	N	38	6.72	38	

Type No.	Grp/Description	Per Unit Sugg.		Factory Order	Incrmnt	
		Resale Price	Price			
MC145444H	N GAS TELEMETER MODEM	N	18	6.72	18	
MC145453FN	L CMOS LCD33-SEG DR SERIAL	1	26	2.83	26	
MC145453P	L CMOS LCD33-SEG DR SERIAL	1	9	2.46	9	
MC145475DW	N ISDN "S&T" TRANSCEIVER	2	26	8.72	26	
MC145483DT	N 13BIT LINEAR CODEC/FILTER	N	66	3.35	66	★ B
MC145483DTR2	N 13BIT LINEAR CODEC/FILTER	N	66	3.40	66	★ B
MC145483DW	N 13BIT LINEAR CODEC/FILTER	N	38	3.22	38	★ B
MC145483DWR2	N 13BIT LINEAR CODEC/FILTER	N	1000	3.27	1000	★ B
MC145483SD	N 13BIT LINEAR CODEC/FILTER	N	66	3.35	66	★ B
MC145483SDR2	N 13BIT LINEAR CODEC/FILTER	N	1500	3.40	1500	★ B
MC145484DW	N 5V PCM CODEC/FILTER	N	38	2.68	38	B
MC145484DWR2	N 5V PCM CODEC/FILTER	2	1000	2.73	1000	B
MC145484SD	N 5V PCM CODEC/FILTER	N	66	2.95	66	B
MC145484SDR2	N 5V PCM CODEC/FILTER	2	1500	3.00	1500	B
MC14549BCL	B CMOS 8-BIT SARCASCADE EABL	3	25	14.04	25	S P †
MC14549BCP	B CMOS 8-BIT SARCASCADE EABL	2	25	8.53	25	S P †
MC1455BD	B TIMER	2	98	.42	98	†
MC1455BDR2	B TIMER	N	2500	.53	2500	★ †
MC1455BP1	B LINTIMER	1	50	.36	1000	†
MC1455D	B LINTIMING CIRCUIT (555)	2	98	.35	98	†
MC1455DR2	B LINTIMING CIRCUIT T/R	N	2500	.38	2500	†
MC1455P1	B LINTIMING CIRCUIT (555)	1	50	.30	1000	†
MC145502FN	N MONOCIRCUIT	2	37	7.26	37	
MC145502P	N 22PIN CODEC/FILTER	2	15	6.92	15	
MC145503DW	N CODEC-FILTER PCMMONOCRCT	1	47	5.13	47	
MC145503P	N 16PIN CODEC/FILTER	1	25	5.13	25	
MC145505DWR2	N FILTER PCMMONO-CIRCUIT	2	1000	5.20	1000	
MC145505P	N 16PIN PCMMONOCIRCUIT	1	25	5.13	25	
MC14551BCP	B CMOS QUAD2-IN ANALOG MUX	1	25	1.63	500	S P †
MC14551BD	B CMOS QUAD2-IN ANALOG MUX	2	48	1.63	48	S P †
MC14551BDR2	B QUAD2-CHANNEL ANALG MUX	2	2500	1.67	2500	S P †
MC14553BCP	B CMOS 3-DIGIT BCD CNTR	2	25	4.45	25	S †
MC145532DW	N ADAPTIVE DIFFERENTIAL PCM	1	47	7.71	47	
MC14555BCP	B CMOS DUAL BIN DECODER	2	25	.47	500	†
MC14555BDR2	B DUL BIN TO1-OF-4 DEC INV	2	2500	.49	2500	†
MC145554DW	N MONOCIRCUIT	2	47	2.86	47	
MC145554DWR2	N MONOCIRCUIT	2	1000	2.93	1000	
MC145554P	N MONOCIRCUIT	1	25	2.86	25	
MC145557DW	N PCM CODEC-FILTER	N	47	2.86	47	
MC145557DWR2	N PCM CODEC-FILTER	N	1000	2.93	1000	
MC145557P	N PCM CODEC-FILTER	N	25	2.86	25	
MC14556BCP	B CMOS DUAL BIN DECODER	2	25	.49	500	†
MC14556BDR2	B INDSTR TIME BASE GENRATR	2	2500	.50	2500	†
MC14557BCL	B CMOS 1 TO 64 BITS/R	3	25	5.24	500	†
MC14557BCP	B CMOS 1 TO 64 BITS/R	2	25	2.07	500	†

A = OSPD/Power
 B = Analog/Logic
 J = Transportation
 L = Consumer
 N = Networking
 V = Wireless

S = Proprietary Device
 B = Motorola Blue Chip Program Device
 P = Phoenix Program
 ★ = First Time in Book
 † = \$200 Minimum Waived

N = Key New Motorola Device
 R = Key "Focus" Motorola Device

1 = Mature, Stable, High-Volume Device
 2 = Moderate-Volume Device
 3 = Low-Volume Device

COMMERCIAL COMPONENTS

Type No.	Grp/Description	Per PC	Unit Qty	Sugg. Resale Price	Factory Order Price	Order Incrmnt	Type No.	Grp/Description	Per PC	Unit Qty	Sugg. Resale Price	Factory Order Price	Order Incrmnt
MC14557BDW	B CMOS1 TO64 BIT S/R	2	47	2.07	47	†	MC1489ADR2	B LIN RS232 RCVR	2	2500	.57	2500	†
MC145572FN	N ISDN2ND GENERATION UCHIP	N	26	20.63	26	B	MC1489AP	B LIN QUAD232D LINE RCVR	1	25	.46	500	†
MC145572FNR2	N ISDN2ND GENERATION UCHIP	2	500	20.68	450	B	MC1489D	B LIN RS232 RCVR	2	55	.53	55	†
MC145572PB	N ISDN2ND GENERATION UCHIP	1	160	17.19	160	B	MC1489DR2	B LIN QD232D LINE RCVR T/R	N	2500	.57	2500*	†
MC145572PBR2	N ISDN2ND GENERATION UCHIP	2	1500	17.24	1500	B	MC1489P	B LIN QUAD232D LINE RCVR	1	25	.46	500	†
MC145574DW	N ISDN SIT INTERFACE TRANSC	N	26	5.79	26	B	MC1490P	V LIN RF/IF/AUDIO AMPLIFIER	2	50	2.03	1000	S P
MC145574PB	N ISDN SIT INTERFACE TRANSC	N	250	5.79	250	B	MC1494P	B LIN4-QUADRNT MULTPLR	N	25	3.56	500	S P †
MC14559BCP	B CMOS1-8 BIT SAR CASCADE	2	25	8.53	25	S P †	MC1496BD	B LIN BAL MODULTR/DEMOLTR	N	55	.83	55	†
MC14562BCP	B CMOS128-BIT STAT S/R	2	25	5.72	25	S P †	MC1496BDR2	B MODULATOR/DEMULATOR	2	55	.83	55	†
MC14566BCP	B CMOS IND. TIME BASE GEN	2	25	1.39	500	†	MC1496BP	B LIN BAL MODULTR/DEMOLTR	N	25	.73	500	†
MC14568BCL	B CMOS PHASE COMP/PROG CTR	3	25	13.82	25	S P †	MC1496D	B LIN BAL MODULTR/DEMOLTR	2	55	.67	55	†
MC14568BCP	B CMOS PHASE COMP/PROG CTR	2	25	4.88	25	S P †	MC1496DR2	B BLNCD MOD DEMOD	N	2500	.57	2500*	†
MC14569BCP	B CMOS DUAL PRG BCD/BICNTR	2	25	2.17	500	S P †	MC1496P	B LIN BAL MODULTR/DEMOLTR	1	25	.58	500	†
MC14572UBCP	B CMOS HEX GATE	2	25	.59	500	†	MC16S2CPU20B1	J 8 BIT MCU	N	420	5.89	420*	B
MC14573D	V QUAD OP AMP	2	48	3.12	48		MC16V1CPU20B1	J 16 BIT MCU,GPT,100 TOFP	N	420	7.39	420	B
MC14573DR2	V QUAD OP AMP	2	2500	3.23	2500		MC16Z1CFC16B1	J 16 BIT MCU,RAM,10 BIT A/D	1	180	10.83	180	B
MC14573P	V QUAD OP AMP	2	25	3.12	25		MC16Z1CFC20B1	J 16 BIT MCU	N	180	11.37	180	B
MC14574P	V QUAD COMPARATOR	2	25	3.12	25		MC16Z1CFC25B1	J 16 BIT MCU,RAM,10 BIT A/D	N	180	11.91	180	B
MC145740F	N DTMF TRANSCEIVER	N	40	5.99	40		MC16Z1CPV16B1	J 16 BIT MCU RAM,10 BIT A/D	N	300	8.63	300	B
MC14575D	V DUAL OP AMP/COMPARATOR	2	48	3.12	48		MC16Z1CPV20B1	J 16 BIT MCU,RAM,10 BIT A/D	N	300	9.06	300	B
MC14575P	V DUAL OP AMP/COMPARATOR	1	25	3.12	25		MC16Z1CPV25B1	J 16 BIT MCU	N	300	9.49	300	B
MC145750VFU	N PAI/4 QPSK ENCODER	N	90	6.98	90		MC16Z2BFCF16B1	J AMCU16BIT MCU2KSRAM	N	180	16.27	180	B
MC14576CF	L DUAL VIDEO AMPLIFIER	N	94	.92	94		MC16Z2BFCF20B1	J AMCU16BIT 2K SRAM	N	180	17.42	180	B
MC14576CP	L DUAL VIDEO AMPLIFIER	N	50	.92	50		MC16Z2BCPV16B1	J AMCU16BIT MCU2KSRAM	N	300	14.08	300	B
MC14577CF	L DUAL VIDEO AMPLIFIER	N	94	.92	94		MC16Z2BCPV20B1	J AMCU16BIT 2K SRAM	N	300	14.88	300	B
MC14577CP	L DUAL VIDEO AMPLIFIER	N	50	.92	50		MC16Z3KACFC16	J 16 BIT MCU,W/RTEK,2KRAM,A/D	N	36	15.11	36*	B
MC1458CD	B LIN (DUAL MC1741) OP AMP	2	98	.38	98	†	MC16Z3KACFC16B1	J 16 BIT MCU,W/RTEK,2KRAM,A/D	N	36	14.33	36*	B
MC1458CDR2	B DUAL OP AMP	N	2500	.38	2500*	†	MC1648D	B MECL ULTGE-CNTRLLD OSCIL	1	98	3.55	98	†
MC1458CP1	B LIN (DUAL MC1741) OP AMP	1	50	.33	1000	†	MC1648FN	B DIG QD PLASTIC PKG	2	46	6.33	46	†
MC1458D	B LIN (DUAL MC1741) OP AMP	2	98	.43	98	†	MC1648L	B MECL VLTGE-CNTRLLD OSCIL	2	25	6.95	25	†
MC1458DR2	B LIN DUAL MC1741 O.A. T/R	2	2500	.47	2500	†	MC1648P	B MECL VLTGE-CNTRLLD OSCIL	1	25	3.52	25	†
MC1458P1	B LIN (DUAL MC1741) OP AMP	2	50	.38	1000	†	MC1650L	B MECL DUAL A/D COMPARATOR	2	25	19.90	25	†
MC14580BCP	B CMOS4X4 MULTIPORT REG	3	15	6.61	15	S †	MC1651L	B MECL DUAL A/D COMPARATOR	2	25	19.90	25	†
MC14584BCL	B CMOS HEX SCHMITT TRIG	2	25	1.15	500	†	MC1658D	B VOLTAGE CONTR MULTIVIBR	N	48	4.47	48	†
MC14584BCP	B CMOS HEX SCHMITT TRIG	1	25	.45	500	†	MC1658L	B MECL VOLT-CNTRLD MULTIVIB	3	25	9.64	25	†
MC14584BD	B CMOS HEX SCHMITT TRIG	2	55	.45	55	†	MC1658P	B MECL VOLT-CNTRLD MULTIVIB	2	25	4.47	25	†
MC14584BDR2	B HEX SCHMITT TRIGGER	2	2500	.49	2500	†	MC1660L	B MECL DUAL 4 INPUT GATE	2	25	11.42	25	†
MC14585BCL	B CMOS4-BIT MAG COMP	2	25	2.39	500	†	MC1662L	B MECL DUAL 4 INPUT GATE	2	25	10.65	25	†
MC14585BCP	B CMOS4-BIT MAG COMP	2	25	.68	500	†	MC1670L	B MECL MASTER-SLAVE FF	2	25	10.53	25	†
MC14585BDR2	B 4-BIT MAGNITUDE COMPARAT	2	2500	.72	2500	†	MC1692L	B MECL QUAD LINE RECEIVER	2	25	10.65	25	†
MC14599BCP	B CMOS8-BIT ADDR LATCH	2	20	4.20	20	S P †	MC1723BD	B VOLTAGE REGULATOR	2	55	.50	55	†
MC1488D	B LIN QUAD232D LINE DRVR	1	55	.53	55	†	MC1723BDR2	B VOLTAGE REGULATOR	N	2500	.48	2500*	†
MC1488DR2	B LIN QD232D LINE DRVR T/R	2	2500	.57	2500	†	MC1723CD	B LIN (723) VOLT REG	2	55	.42	55	†
MC1488P	B LIN QUAD232D LINE DRVR	1	25	.46	500	†	MC1723CDR2	B LIN ADJ POS/NEG REG T/R	N	2500	.42	2500*	†
MC1489AD	B LIN RS232 RCVR	2	55	.53	55	†	MC1723CP	B LIN (723) VOLT REG	2	25	.36	500	†

A = OSPD/Power
 B = Analog/Logic
 J = Transportation
 L = Consumer
 N = Networking
 V = Wireless

S = Proprietary Device
 B = Motorola Blue Chip Program Device
 P = Phoenix Program
 * = First Time in Book
 † = \$200 Minimum Waived

N = Key New Motorola Device
 R = Key "Focus" Motorola Device

1 = Mature, Stable, High-Volume Device
 2 = Moderate-Volume Device
 3 = Low-Volume Device

EFFECTIVE DATE: JANUARY 10, 1998

COMMERCIAL COMPONENTS

Type No.	Grp/Description	Per Unit Sugg. Factory				
		Resale Price	Price	Order		
PC	Qty	Price	Incrrmnt			
MC1741CP1	B LININT COMP/HI PERF O.A.	N	50	.67	1000	†
MC1776CD	B LINMCRPWR PROGRMBLO.A.	2	98	.70	98	†
MC1776CDR2	B PROG OP AMP	N	2500	.63	2500 *	†
MC1776CP1	B LINMCRPWR PROGRMBLO.A.	2	50	.61	1000	†
MC26C31D	N EIA422 LINE DRIVER	N	48	1.04	48	
MC26C32D	N EIA422 LINE DRIVER	N	48	1.04	48	
MC26LS30D	B EIA-422/423 DRIVER	2	48	1.22	48	†
MC26LS30DR2	B EIA-422/423 DRIVER	2	2500	1.25	2500	†
MC2830D	L VOICE ACTIVATED SWITCH	2	98	1.76	98	S P
MC2830DR2	L VOICE ACTIVATED SWITCH	2	2500	1.76	2500	S P
MC2833D	V FM TRANSMITTER IC	2	48	.76	48	S
MC2833DR2	V FM TRANSMITTER IC	2	2500	.76	2500	S
MC2833P	V LIN LOW PWR FM XMT SYS	2	25	.76	500	S
MC3302D	B LIN QUAD SNGL SPLY COMP	N	55	.58	55 *	†
MC3302DR2	B LIN QUAD COMP	2	2500	.50	2500	†
MC3302P	B LIN QUAD SNGL SPLY COMP	1	25	.44	500	†
MC33023DW	B HI-SPD PWM CONTROLLER	N	47	5.46	47	†
MC33023DWR2	B HI-SPD PWM CONTROLLER	2	1000	5.46	1000	†
MC33023P	B HI-SPD PWM CONTROLLER	N	25	5.46	500	†
MC33025P	B HI-SPD PWM CONTROLLER	N	25	6.08	500	†
MC3303D	B LIN QUAD DIFF INPT OP AMP	N	55	.48	55	†
MC3303DR2	B LIN QD DIFF INPT OP AMP	2	2500	.52	2500	†
MC3303P	B LIN QUAD DIFF INPT OP AMP	2	25	.42	500	†
MC33030DW	B CONTROLLER DRIVER	2	47	4.88	47	S P †
MC33030DWR2	B CONTROLLER DRIVER	2	1000	4.88	1000	S P †
MC33030P	B LIN DC SRVOMTR CNTR/DRVR	1	25	4.70	25	S P †
MC33033DW	B LIN BRSL DC MTR CNTRLR	N	38	2.84	38	S P †
MC33033DWR2	B LIN BRSL DC MTR CNTRLR	N	1000	2.92	1000 *	S P †
MC33033P	B LIN BRSL DC MTR CNTRLR	1	18	2.70	360	S P †
MC33035DW	B LIN BRSHLS DC MTR CNTRLR	2	30	3.35	30	S P †
MC33035DWR2	B LIN BRSHLS DC MTR CNTRLR	2	1000	3.74	1000	S P †
MC33035P	B BRSHLES DC MOTOR CNTRLR	1	15	2.88	15	S P †
MC33039D	B LIN CL-LOOP BRSHMTRADPT	2	98	1.28	98	S P †
MC33039DR2	B LIN CL-LOOP BRSHMTRADPT	2	2500	1.31	2500	S P †
MC33039P	B LIN CL-LOOP BRSHMTRADPT	1	50	1.28	1000	S P †
MC33060AD	B PWM POWER SUPPLY CONTROL	2	55	1.87	55	S P †
MC33060ADR2	B SWTCHMODE PWM CONTROL CKT	2	2500	1.91	2500	S P †
MC33060AP	B LIN SWTCHMODE PWM CNTR CKT	N	25	1.87	500	S P †
MC33063AD	B LIN PULSE WIDTH MOD	N	98	2.56	98	†
MC33063ADR2	B PULSE WIDTH MOD	2	2500	2.60	2500	†
MC33063AP1	B LIN PWM CNTRL CRCT	1	50	2.56	1000	†
MC33063AVD	B DC BRUSHLES MTR CNTRL CKT	N	98	2.56	98	†
MC33064D-005	B LIN UNDRVOLTAG SNSNG CRCT	1	98	1.10	98	†
MC33064D-5R2	B LIN UNDRVOLTAGE CRCT	N	2500	1.13	2500	†
MC33064P-005	B LIN UNDRVOLTAG SNSNG CRCT	1	2000	1.07	2000	†

Type No.	Grp/Description	Per Unit Sugg. Factory				
		Resale Price	Price	Order		
PC	Qty	Price	Incrrmnt			
MC33064P-5RA	B UNDERVOLT. CIRCUIT	2	2000	1.10	2000	†
MC33064P-5RP	B UNDERVOLT. CIRCUIT	2	2000	1.13	2000	†
MC33065DW	B LINDL CRNT-MODE CONTRLR	N	47	2.70	47	S P †
MC33065DW-H	B LINDL CRNT-MODE CONTRLR	N	47	2.70	47	S P †
MC33065DW-HR2	B LINDL CRNT-MODE CONTRLR	N	1000	2.72	1000 *	S P †
MC33065DW-L	B LINDL CRNT-MODE CONTRLR	N	47	2.70	47	S P †
MC33065DW-LR2	B LINDL CRNT-MODE CONTRLR	N	1000	3.25	1000 *	S P †
MC33065P	B LINDL CRNT-MODE CONTRLR	N	25	2.70	500	S P †
MC33065P-L	B LINDL CRNT-MODE CONTRLR	N	25	2.70	500	S P †
MC33066DW	B LIN RESONANT MDCNTRL	2	47	5.08	47	S P †
MC33066DWR2	B LIN RESONANT MDCNTRL	N	1000	5.08	1000 *	S †
MC33066P	B LIN RESONANT MDCNTRL	3	25	6.06	500	S P †
MC33067DW	B RESONANT SUPPLY CNTRL	2	47	3.98	47	S P †
MC33067DWR2	B RESONANT SUPPLY CNTRL	N	1000	2.83	1000 *	S P †
MC33067P	B RESONANT SUPPLY CNTRL	2	25	3.76	500	S P †
MC33071AD	B LIN HI PRF/SNGL SPLY O.A.	2	98	1.29	98	†
MC33071ADR2	B LIN HI PRF/SNGL SPLY O.A.	2	2500	1.33	2500	†
MC33071AP	B LIN HI PRF/SNGL SPLY O.A.	2	50	1.29	1000	†
MC33071D	B LIN HI PRF/SNGL SPLY O.A.	N	98	1.12	98	†
MC33071DR2	B OP AMP	2	2500	1.16	2500	†
MC33071P	B LIN HI PRF/SNGL SPLY O.A.	2	50	1.12	1000	†
MC33072AD	B LIN HI PRF/SNGL SPLY O.A.	N	98	1.72	98	†
MC33072ADR2	B LIN OP AMP	2	2500	1.76	2500	†
MC33072AP	B LIN HI PRF/SNGL SPLY O.A.	2	50	1.72	1000	†
MC33072D	B LIN HI PRF/SNGL SPLY O.A.	1	98	1.14	98	†
MC33072DR2	B LIN HI PRF/SNGL SPLY O.A.	2	2500	1.18	2500	†
MC33072P	B LIN HI PRF/SNGL SPLY O.A.	1	50	1.14	1000	†
MC33074AD	B LIN HI PRF/SNGL SPLY O.A.	2	55	2.49	55	†
MC33074ADR2	B LIN HI PRF/SNGL SPLY O.A.	2	2500	2.17	2500	†
MC33074AP	B LIN HI PRF/SNGL SPLY O.A.	2	25	2.17	500	†
MC33074D	B LIN HI PRF/SNGL SPLY O.A.	1	55	1.55	55	†
MC33074DR2	B LIN QUAD OP AMPS	2	2500	1.89	2500	†
MC33074P	B LIN HI PRF/SNGL SPLY O.A.	1	25	1.85	500	†
MC33076D	B DL BIPOLAR AMP	2	98	1.61	98	†
MC33076DR2	B DL BIPOLAR AMP	2	2500	1.61	2500	†
MC33076P1	B DL BIPOLAR AMP	2	50	1.61	1000	†
MC33076P2	B DUAL AMPLIFIER	2	25	1.61	500	†
MC33077D	B LIN HI PRF/SNGL SPLY O.A.	2	98	1.91	98	†
MC33077DR2	B LIN HI PRF/SNGL SPLY O.A.	2	2500	1.96	2500	†
MC33077P	B LIN DUAL/LOW NOISE OP AMP	2	50	1.91	1000	†
MC33078D	B LIN DUAL/LOW NOISE OP AMP	1	98	1.18	98	†
MC33078DR2	B LIN DUAL/LOW NOISE OP AMP	2	2500	1.23	2500	†
MC33078P	B LIN DUAL/LOW NOISE OP AMP	1	50	1.18	1000	†
MC33079D	B LIN QUAD/LOW NOISE OP AMP	2	55	2.04	55	†
MC33079DR2	B LIN QUAD/LOW NOISE OP AMP	2	2500	2.09	2500	†

A = OSPD/Power
 B = Analog/Logic
 J = Transportation
 L = Consumer
 N = Networking
 V = Wireless

S = Proprietary Device
 B = Motorola Blue Chip Program Device
 P = Phoenix Program
 * = First Time in Book
 † = \$200 Minimum Waived

N = Key New Motorola Device
 R = Key "Focus" Motorola Device

1 = Mature, Stable, High-Volume Device
 2 = Moderate-Volume Device
 3 = Low-Volume Device

COMMERCIAL COMPONENTS

Type No.	Grp/Description	Per PC	Unit Qty	Sugg. Resale Price	Factory Order Incrmt	
MC33079P	B LIN QUAD/LOW NOISE OP AMP	1	25	2.04	500	†
MC33091AD	J HI-SIDE T MOS DRIVER	N	98	1.48	98	S
MC33091ADR2	J HI-SIDE T MOS DRIVER	2	2500	1.53	2500	S
MC33091AP	J HI-SIDE T MOS DRIVER	N	50	1.48	1000	S
MC33102D	B DUAL SLEEP MODE AMP	2	98	1.48	98	S P †
MC33102DR2	B DUAL SLEEP MODE AMP	2	2500	1.53	2500	S P †
MC33102P	B DUAL SLEEP MODE AMP	2	50	1.48	1000	S P †
MC33110D	V COMPANDER	2	55	2.18	55	S P
MC33110DR2	V COMPANDER	N	2500	1.62	2500	★ S P
MC33110P	V COMPANDER	2	25	2.18	500	S P
MC33111D	V COMPANDAR II	N	48	1.98	48	S P
MC33111DR2	V COMPANDAR II	2	2500	1.98	2500	S P
MC33111P	V COMPANDAR II	N	25	1.98	500	S P
MC33120FN	L HIGH VOLTAGE SLIC	2	37	11.29	37	S P
MC33120P	L HIGH VOLTAGE SLIC	2	18	11.29	18	S P
MC33121FN	L SLIC III	2	37	11.29	37	S P
MC33121FNR2	L SLIC III	2	500	11.29	500	S P
MC33121P	L SLIC III	2	18	11.29	360	S P
MC33128D	V DECT POWER MGT IC	N	48	3.06	48	S P
MC33128DR2	V DECT POWER MGT IC	N	2500	3.10	2500	S P
MC33129D	L LIN HI PERF CUR MODE CNTR	2	55	3.33	55	S P
MC33129DR2	L LIN HI PERF CUR MODE CNTR	2	2500	3.37	2500	S P
MC33129P	L LIN HI PERF CUR MODE CNTR	2	25	3.33	500	S P
MC33143DW	J DUAL HIGH SIDE SWITCH	N	30	7.02	30	S
MC33143DWR2	J DUAL HIGH SIDE SWITCH	2	1000	7.06	1000	S
MC33151D	B LIN HI-SPD DL MOSFT DRVR	2	98	2.11	98	†
MC33151DR2	B DUAL MOSFET DRIVER	2	2500	2.15	2500	†
MC33151P	B LIN HI-SPD DL MOSFT DRVR	2	50	2.11	1000	†
MC33151VD	B HI SPD DUAL MOSFET DRIVER	N	98	2.11	98	†
MC33151VP	B HI SPD DUAL MOSFET DRIVER	N	50	2.11	1000	†
MC33152D	B LIN HI-SPD DL MOSFT DRVR	2	98	2.11	98	†
MC33152DR2	B MOSFET DRVR	2	2500	2.15	2500	†
MC33152P	B LIN HI-SPD DL MOSFT DRVR	2	50	2.11	1000	†
MC33153D	B IGBT GATE DRIVER IC	N	98	2.04	98	†
MC33153DR2	B IGBT GATE DRIVER IC	2	2500	2.04	2500	†
MC33153P	B SINGLE IGBT GATE DRIV. IC	N	50	2.04	1000	†
MC33154D	B IGBT GATE DRIVER	N	98	1.94	98	†
MC33154P	B IGBT GATE DRIVER	N	50	1.94	1000	†
MC33160DW	B LIN MCROPROSSOR VOLT REG	2	47	2.90	47	S P †
MC33160DWR2	B LIN MCROPROSSOR VOLT REG	2	1000	2.11	1000	S P †
MC33160P	B LIN MCROPROSSOR VOLT REG	2	25	2.07	500	S P †
MC33161D	B LIN UNIV VOLTAGE MONITOR	N	98	1.51	98	†
MC33161DR2	B LIN UNIV VOLT MONITOR	2	2500	1.55	2500	†
MC33161P	B LIN UNIV VOLTAGE MONITOR	N	50	1.51	1000	†
MC33163DW	B LIN POWER SW REG	2	47	3.82	47	S P †

Type No.	Grp/Description	Per PC	Unit Qty	Sugg. Resale Price	Factory Order Incrmt	
MC33163DWR2	B POWER SWITCHING REGULATOR	2	1000	3.82	1000	S P †
MC33163P	B LIN POWER SWITCHING REG	N	25	3.64	500	S P †
MC33164D-003	B MICROPWR UNDRVOLT SENSOR	2	98	1.46	98	†
MC33164D-005	B MICROPWR UNDRVOLT SENS	2	98	1.46	98	†
MC33164D-3R2	B MCRP PWR UNDRVOLT SENSOR	2	2500	1.51	2500	†
MC33164D-5R2	B MICROPWR UNDRVOLT SENSE	2	2500	1.51	2500	†
MC33164DM-003	B UNDER VOLTAGE CIRCUIT	N	2500	1.31	2500	†
MC33164DM-005	B UNDER VOLTAGE CIRCUIT	N	2500	1.31	2500	†
MC33164P-003	B MICROPWR UNDRVOLT SENSOR	2	2000	1.46	2000	†
MC33164P-005	B MICROPWR UNDRVOLT SENS	1	2000	1.46	2000	†
MC33164P-3RA	B UNDRVOLT SENSE	2	2000	1.44	2000	†
MC33164P-3RP	B UNDRVOLT SENSE	2	2000	1.44	2000	†
MC33164P-5RA	B UNDRVOLT SENSE	2	2000	1.44	2000	†
MC33164P-5RP	B UNDRVOLT SENSE	2	2000	1.44	2000	†
MC33165DW	B LAST ORDER DATE:06/30/98	2	47	3.16	47	†
MC33165DWR2	B LAST ORDER DATE:06/30/98	2	1000	3.18	1000	†
MC33165P	B LAST ORDER DATE:06/30/98	2	25	3.14	500	†
MC33166T	B LIN PWR SWITCHING REG	1	50	5.20	50	†
MC33166TH	B LIN PWR SWITCHING REG	N	50	5.44	50	†
MC33166TV	B 3AMP FIX FREQ DC-DC CNVRT	N	50	5.44	50	†
MC33167T	B LINEAR PWR SWITCHING REG	N	50	5.87	50	†
MC33167TV	B LIN PWR SWITCHING REG	N	50	6.08	50	†
MC33169DTB-004	B GAAS POW AMP SUPPIC	N	96	2.09	96	S P †
MC33171D	B LIN LO PWR/SNGL SPLY O.A.	N	98	1.70	98	†
MC33171DR2	B LO PWR SS OP AMP	2	2500	1.74	2500	†
MC33171P	B LIN LO PWR/SNGL SPLY O.A.	2	50	1.70	1000	†
MC33172D	B LIN LO PWR/SNGL SPLY O.A.	1	98	1.85	98	†
MC33172DR2	B LO PWR SS OP AMP	2	2500	1.89	2500	†
MC33172P	B LIN LO PWR/SNGL SPLY O.A.	1	50	1.85	1000	†
MC33174D	B LIN LO PWR/SNGL SPLY O.A.	1	55	2.80	55	†
MC33174DR2	B LO PWR SS OP AMP	2	2500	2.84	2500	†
MC33174P	B LIN LO PWR/SNGL SPLY O.A.	2	25	2.80	500	†
MC33174VD	B LIN LO PWR/SNGL SPLY O.A.	N	55	3.27	55	†
MC33174VDR2	B LIN LO PWR/SNGL SPLY O.A.	2	2500	2.47	2500	†
MC33178D	B DUAL LO POWER OP AMP	1	98	1.55	98	†
MC33178DR2	B QD/DUAL LO PWR OP AMP	2	2500	1.59	2500	†
MC33178P	B DUAL LO POWER OP AMP	1	50	1.55	1000	†
MC33179D	B QD LO-NOISE AMP	2	55	2.32	55	†
MC33179DR2	B QD/DUAL LO PWR OP AMP	2	2500	2.21	2500	†
MC33179P	B QD LO-NOISE AMP	2	25	2.17	500	†
MC33181D	B LIN LO PWR JFET INPT O.A.	N	98	1.33	98	†
MC33181DR2	B LIN OP AMP	N	2500	1.38	2500	★ †
MC33181P	B LIN LO PWR JFET INPT O.A.	N	50	1.33	1000	†
MC33182D	B LIN LO PWR JFET INPT O.A.	1	98	1.57	98	†
MC33182DR2	B LIN OP AMP	2	2500	1.61	2500	†

- A = OSPD/Power
- B = Analog/Logic
- J = Transportation
- L = Consumer
- N = Networking
- V = Wireless
- S = Proprietary Device
- B = Motorola Blue Chip Program Device
- P = Phoenix Program
- ★ = First Time in Book
- † = \$200 Minimum Waived
- N = Key New Motorola Device
- R = Key "Focus" Motorola Device
- 1 = Mature, Stable, High-Volume Device
- 2 = Moderate-Volume Device
- 3 = Low-Volume Device

EFFECTIVE DATE: JANUARY 10, 1998

COMMERCIAL COMPONENTS

Type No.	Grp/Description	Per Unit Sugg.		Factory Order	Incrmnt	
		Resale Price	Price			
MC33182P	B LINLOPWRJFETINPT.O.A.	2	50	1.57	1000	†
MC33184D	B LINLOPWRJFETINPT.O.A.	2	55	2.69	55	†
MC33184DR2	B LINLOPWRJFETINPT.O.A.	2	2500	2.73	2500	†
MC33184P	B LINLOPWRJFETINPT.O.A.	2	25	2.69	500	†
MC33193D	J AUTOMOTIVE DIRECTION INDI	N	98	.90	98	S
MC33193DR2	J AUTOMOTIVE DIRECTION INDI	2	2500	.94	2500	S
MC33193P	J AUTOMOTIVE DIRECTION INDI	N	50	.90	50	S
MC33199D	J SERIAL LINK DRIVER	N	55	1.55	55	S
MC33199DR2	J AUTO SERIAL LINK DRIVER	2	2500	1.58	2500	S
MC33201D	B SINGLE RAIL-RAIL AMP	R	98	1.31	98	†
MC33201DR2	B SINGLE RAIL-RAIL AMP	2	2500	1.35	2500	†
MC33201P	B SINGLE RAIL-RAIL AMP	R	50	1.31	1000	†
MC33201VD	B SINGLE RAIL-RAIL AMP	N	98	1.31	98	†
MC33201VP	B SINGLE RAIL-RAIL AMP	N	50	1.31	1000	†
MC33202D	B DUAL RAIL-RAIL AMPLIFIER	R	98	1.83	98	†
MC33202DR2	B DUAL RAIL-RAIL AMPLIFIER	2	2500	1.87	2500	†
MC33202P	B DUAL RAIL-RAIL AMPLIFIER	R	50	1.83	1000	†
MC33202VD	B RAIL TO RAIL OP AMPS	N	98	1.83	98	†
MC33202VP	B RAIL TO RAIL OP AMPS	N	50	1.83	1000	†
MC33204D	B QUAD RAIL-RAIL AMPLIFIER	R	55	2.24	55	†
MC33204DR2	B QUAD RAIL-RAIL AMPLIFIER	2	2500	2.28	2500	†
MC33204DTB	B QUAD RAIL TO RAIL AMP	N	96	2.24	96	†
MC33204P	B QUAD RAIL-RAIL AMPLIFIER	R	25	2.24	500	†
MC33204VD	B QUAD RAIL TO RAIL AMP	N	55	2.24	55	†
MC33204VP	B QUAD RAIL TO RAIL AMP	N	25	2.24	500	†
MC33206D	B DUAL RAIL TO RAIL DISABLE	N	55	2.02	55	†
MC33206DR2	B DUAL RAIL TO RAIL DISABLE	2	2500	2.02	2500	†
MC33206P	B DUAL RAIL TO RAIL DISABLE	N	25	2.02	500	†
MC33207D	B QUAD RAIL TO RAIL W/DISAB	N	48	2.45	48	†
MC33207DR2	B QUAD RAIL TO RAIL W/DISAB	2	2500	2.45	2500	†
MC33207P	B QUAD RAIL TO RAIL W/DISAB	N	25	2.45	500	†
MC33215B	L SPEAKERPHONE	N	1	5.51	1	S P
MC33218ADW	L SPEAKERPHONE WITH SPI	N	30	5.11	30	S P
MC33218ADWR2	L SPEAKERPHONE WITH SPI	2	1000	5.11	1000	S P
MC33218AP	L SPEAKERPHONE WITH SPI	N	15	5.11	15	S P
MC33219ADW	L SPEAKERPHONE IVA	N	30	4.23	30	S P
MC33219ADWR2	L SPEAKERPHONE IVA	2	1000	4.23	1000	S P
MC33219AP	L SPEAKERPHONE IVA	N	15	4.23	15	S P
MC33261D	B POWERFACTOR CORRECTION	N	98	1.98	98	†
MC33261DR2	B PFC	2	2500	2.60	2500	†
MC33261P	B POWERFACTOR CORRECTION	N	50	2.56	1000	†
MC33262D	B POWERFACTOR CORRECTION	N	98	1.98	98	†
MC33262DR2	B POWERFACTOR CORRECTION	N	2500	1.61	2500	†
MC33262P	B POWERFACTOR CORRECTION	N	50	1.57	1000	†
MC33264D-2.8	B LODRPOUT VOLT REG W/ENBL	N	98	1.46	98	†

Type No.	Grp/Description	Per Unit Sugg.		Factory Order	Incrmnt	
		Resale Price	Price			
MC33264D-3.0	B LOWDROPOUT VOLTAGE REG	N	98	1.46	98	S P †
MC33264D-3.3	B LOWDROPOUT VOLTAGE REG	N	98	1.46	98	†
MC33264D-3.8	B LODRPOUT VOLT REG W/ENBL	N	98	1.46	98	†
MC33264D-4.0	B LODRPOUT VOLT REG W/ENBL	N	98	1.46	98	†
MC33264D-4.75	B LODRPOUT VOLT REG W/ENBL	N	98	1.46	98	†
MC33264D-5.0	B LOWDROPOUT VOLTAGE REG	N	98	1.46	98	†
MC33264DM-2.8	B LODRPOUT VOLT REG W/ENBL	N	2500	1.61	2500	†
MC33264DM-3.0	B LODRPOUT VOLT REG W/ENBL	N	2500	1.61	2500	†
MC33264DM-3.3	B LODRPOUT VOLT REG W/ENBL	N	2500	1.61	2500	†
MC33264DM-3.8	B LODRPOUT VOLT REG W/ENBL	N	2500	1.61	2500	†
MC33264DM-4.0	B LODRPOUT VOLT REG W/ENBL	N	2500	1.61	2500	†
MC33264DM-4.75	B LODRPOUT VOLT REG W/ENBL	N	2500	1.61	2500	†
MC33264DM-5.0	B LODRPOUT VOLT REG W/ENBL	N	2500	1.61	2500	†
MC33267D2T	B LO DIFF POS+ VOLT REG	N	50	2.71	500	†
MC33267T	B LO DIFF POS+ VOLT REG	2	50	2.21	50	S P †
MC33269D	B LO DIF500MA POS/HDI POST	2	98	1.19	98	†
MC33269D-012	B LO DIF500MA POS/HDI POST	2	98	1.19	98	†
MC33269D-3.3	B LO DIF500MA POS/HDI POST	2	98	1.19	98	†
MC33269D-5.0	B LO DIF500MA POS/HDI POST	2	98	1.19	98	†
MC33269DR2	B LO DIF500MA POS/HDI POST	2	2500	1.23	2500	†
MC33269DR2-012	B LO DIF500MA POS/HDI POST	N	98	1.25	98	★ †
MC33269DR2-3.3	B LO DIF500MA POS/HDI POST	N	2500	1.25	2500	★ †
MC33269DR2-5.0	B LO DIF500MA POS/HDI POST	N	2500	1.25	2500	★ †
MC33269DT	B LO DIF500MA POS/HDI POST	2	75	1.35	75	†
MC33269DT-012	B LO DIF500MA POS/HDI POST	2	75	1.35	75	†
MC33269DT-3.3	B LO DIF500MA POS/HDI POST	2	75	1.35	75	†
MC33269DT-5.0	B LO DIF500MA POS/HDI POST	2	75	1.35	75	†
MC33269DTRK	B LO DIF500MA POS/HDI POST	2	2500	1.40	2500	†
MC33269DTRK-012	B LO DIF500MA POS/HDI POST	2	2500	1.40	2500	†
MC33269DTRK-3.3	B LO DIF500MA POS/HDI POST	2	2500	1.40	2500	†
MC33269DTRK-5.0	B LO DIF500MA POS/HDI POST	2	2500	1.40	2500	†
MC33269T	B LO DIF500MA POS/HDI POST	N	50	1.35	50	†
MC33269T-012	B LO DIF500MA POS/HDI POST	N	50	1.35	50	†
MC33269T-3.3	B LO DIF500MA POS/HDI POST	N	50	1.35	50	†
MC33269T-5.0	B LO DIF500MA POS/HDI POST	N	50	1.35	50	†
MC33272AD	B DUAL OP AMP	2	98	1.94	98	†
MC33272ADR2	B DUAL OP AMP	2	2500	1.98	2500	†
MC33272AP	B DUAL OP AMP	2	50	1.94	1000	†
MC33274AD	B QUAD OP AMP	2	55	2.49	55	†
MC33274ADR2	B QUAD OP AMP	2	2500	2.54	2500	†
MC33274AP	B QUAD OP AMP	2	25	2.49	500	†
MC33282D	B LINDUAL OP AMP	N	98	2.04	98	†
MC33282DR2	B OP AMP	2	2500	2.09	2500	†
MC33282P	B LINDUAL OP AMP	N	50	2.04	1000	†
MC33284D	B LINDUAL OP AMP	N	55	3.16	55	†

A = OSPD/Power
 B = Analog/Logic
 J = Transportation
 L = Consumer
 N = Networking
 V = Wireless

S = Proprietary Device
 B = Motorola Blue Chip Program Device
 P = Phoenix Program
 ★ = First Time in Book
 † \$200 Minimum Waived

N = Key New Motorola Device
 R = Key "Focus" Motorola Device

1 = Mature, Stable, High-Volume Device
 2 = Moderate-Volume Device
 3 = Low-Volume Device

COMMERCIAL COMPONENTS

Type No.	Grp/Description	Per Unit Sugg. Factory					Type No.	Grp/Description	Per Unit Sugg. Factory				
		PC	Qty	Price	Order				PC	Qty	Price	Order	
MC33284DR2	B LIN QD JFET OP AMP	N	2500	3.20	2500	†	MC33463H-50KT1	B DC-DC CONVERTER	2	1000	.64	1000	†
MC33284P	B LIN QD JFET OP AMP	2	25	3.16	500	†	MC33463H-50LT1	B DC-DC CONVERTER	2	1000	.64	1000	†
MC33290D	J ISO LINK IC	N	98	1.44	98	S	MC33464H-09AT1	B VOLTAGE DETECTOR	2	1000	.36	1000	†
MC33290DR2	J ISO LINK IC	N	2500	1.48	2500	S	MC33464H-09CT1	B VOLTAGE DETECTOR	2	1000	.36	1000	†
MC33290P	J ISO LINK IC	N	50	1.44	1000	S	MC33464H-20AT1	B VOLTAGE DETECTOR	2	1000	.36	1000	†
MC33298DWR2	J OCTAL SERIAL SWITCH (OSS)	2	1000	6.03	1000	S	MC33464H-20CT1	B VOLTAGE DETECTOR	2	1000	.36	1000	†
MC33298P	J OCTAL SERIAL SWITCH	N	18	5.99	360	S	MC33464H-27AT1	B VOLTAGE DETECTOR	2	1000	.36	1000	†
MC33304D	B QDRAIL-RAIL SLEEP MODE	N	55	2.16	55	S P †	MC33464H-27CT1	B VOLTAGE DETECTOR	2	1000	.36	1000	†
MC33304DR2	B QDRAIL-RAIL SLEEP MODE	2	2500	2.16	2500	S P †	MC33464H-30AT1	B VOLTAGE DETECTOR	2	1000	.36	1000	†
MC33304P	B QDRAIL-RAIL SLEEP MODE	N	25	2.16	500	S P †	MC33464H-30CT1	B VOLTAGE DETECTOR	2	1000	.36	1000	†
MC33340D	B BATTERY CHARGE CONTROLLER	N	98	3.20	98	†	MC33464H-45AT1	B VOLTAGE DETECTOR	2	1000	.36	1000	†
MC33340DR2	B BATTERY CHARGE CONTROLLER	N	2500	3.25	2500	★ †	MC33464H-45CT1	B VOLTAGE DETECTOR	2	1000	.36	1000	†
MC33340P	B BATTERY CHARGE CONTROLLER	N	50	3.10	1000	†	MC33464N-09ATR	B VOLTAGE DETECTOR	2	3000	.36	3000	†
MC33341D	B BATTERY CHARGER	N	98	1.01	98	S P †	MC33464N-09CTR	B VOLTAGE DETECTOR	2	3000	.36	3000	†
MC33341DR2	B BATTERY CHARGER	N	2500	1.04	2500	★ S P †	MC33464N-20ATR	B VOLTAGE DETECTOR	2	3000	.36	3000	†
MC33341P	B BATTERY CHARGER	N	50	1.20	1000	S P †	MC33464N-20CTR	B VOLTAGE DETECTOR	2	3000	.36	3000	†
MC33347D	B BATTERY CHARGE CONTROLLER	N	48	1.46	48	★ S P †	MC33464N-27ATR	B VOLTAGE DETECTOR	2	3000	.36	3000	†
MC33347DTB	B BATTERY CHARGE CONTROLLER	N	96	2.12	96	★ S P †	MC33464N-27CTR	B VOLTAGE DETECTOR	2	3000	.36	3000	†
MC33348D-001	B 1 CELL LITHIUM BAT PROTEC	N	98	1.33	98	†	MC33464N-30ATR	B VOLTAGE DETECTOR	2	3000	.36	3000	†
MC33348D-002	B 1 CELL LITHIUM BAT PROTEC	N	98	1.33	98	†	MC33464N-30CTR	B VOLTAGE DETECTOR	2	3000	.36	3000	†
MC33348D-003	B 1 CELL LITHIUM BAT PROTEC	N	98	1.33	98	†	MC33464N-45ATR	B VOLTAGE DETECTOR	2	3000	.36	3000	†
MC33348D-004	B 1 CELL LITHIUM BAT PROTEC	N	98	1.33	98	†	MC33464N-45CTR	B VOLTAGE DETECTOR	2	3000	.36	3000	†
MC33348D-005	B 1 CELL LITHIUM BAT PROTEC	N	98	1.33	98	†	MC33465N-09ATR	B VOLTAGE DETECTOR	2	3000	.31	3000	†
MC33348D-006	B 1 CELL LITHIUM BAT PROTEC	N	98	1.33	98	†	MC33465N-09CTR	B VOLTAGE DETECTOR	2	3000	.31	3000	†
MC3335P	V FM LOW POWER RECEIVER	N	18	2.02	18	S	MC33465N-20ATR	B VOLTAGE DETECTOR	2	3000	.31	3000	†
MC33362DW	B H IVOLT SWITCHING REG	N	47	2.07	47	S P †	MC33465N-20CTR	B VOLTAGE DETECTOR	2	3000	.31	3000	†
MC33362DWR2	B H IVOLT SWITCHING REG	N	1000	2.11	1000	★ S P †	MC33465N-27ATR	B VOLTAGE DETECTOR	2	3000	.31	3000	†
MC33362P	B OFF-LINE SWITCHING REG	N	47	2.07	47	S P †	MC33465N-27CTR	B VOLTAGE DETECTOR	2	3000	.31	3000	†
MC33363ADW	B H IVOLT SWITCH REG	N	47	2.45	47	S P †	MC33465N-30ATR	B VOLTAGE DETECTOR	2	3000	.31	3000	†
MC33363ADWR2	B H IVOLT SWITCH REG	N	1000	2.48	1000	★ S P †	MC33465N-30CTR	B VOLTAGE DETECTOR	2	3000	.31	3000	†
MC33363AP	B H IVOLT SWITCH REG	N	25	2.45	500	S P †	MC33465N-45ATR	B VOLTAGE DETECTOR	2	3000	.31	3000	†
MC33363DW	B H IVOLT SWITCH REGULATOR	N	47	2.36	47	S P †	MC33465N-45CTR	B VOLTAGE DETECTOR	2	3000	.31	3000	†
MC33363DWR2	B H IVOLT SWITCH REGULATOR	2	1000	2.38	1000	S P †	MC33466H-30JT1	B DC-DC CONVERTER	2	1000	.64	1000	†
MC33363P	B UNIVRSL OFF-LNSW TCH REG	N	25	2.36	500	S P †	MC33466H-30LT1	B DC-DC CONVERTER	2	1000	.64	1000	†
MC33368D	B OFF LN PFC IC W/VOLT REF	N	48	2.38	48	S P †	MC33466H-33JT1	B DC-DC CONVERTER	2	1000	.64	1000	†
MC33368DR2	B OFF LN PFC IC W/VOLT REF	2	2500	2.41	2500	S P †	MC33466H-33LT1	B DC-DC CONVERTER	2	1000	.64	1000	†
MC33368P	B OFF LN PFC IC W/VOLT REF	N	25	2.84	500	S P †	MC33466H-50JT1	B DC-DC CONVERTER	2	1000	.64	1000	†
MC3340P	L LINE ELECTRONIC ATTENUATOR	1	50	1.71	1000	S P	MC33466H-50LT1	B DC-DC CONVERTER	2	1000	.64	1000	†
MC3346D	B LIN GEN PUR XISTOR ARRAY	N	55	.80	55	†	MC33502D	B DUAL MOSFET 1V OP AMP	N	98	1.80	98	S †
MC3346DR2	B TRANSISTOR ARRAY	2	2500	.80	2500	†	MC33502DR2	B DUAL MOSFET 1V OP AMP	N	2500	1.34	2500	★ S †
MC3346P	B LIN GEN PUR XISTOR ARRAY	2	25	.70	500	†	MC33502P	B DUAL MOSFET 1V OP AMP	N	50	1.80	1000	S †
MC33463H-30KT1	B DC-DC CONVERTER	2	1000	.64	1000	†	MC3356DW	V LIN WIDE BAND FSK RECVR	2	38	1.75	38	S P
MC33463H-30LT1	B DC-DC CONVERTER	2	1000	.64	1000	†	MC3356DWR2	V LIN WIDE BAND FSK RECVR	2	1000	1.78	1000	S P
MC33463H-33KT1	B DC-DC CONVERTER	2	1000	.64	1000	†	MC3356P	V LIN WIDE BAND FSK RECEIVER	2	18	1.75	360	S P
MC33463H-33LT1	B DC-DC CONVERTER	2	1000	.64	1000	†	MC33560ADTB	L SMART CARD READER	N	1	2.65	1	★

A = OSPD/Power
B = Analog/Logic
J = Transportation
L = Consumer
N = Networking
V = Wireless

S = Proprietary Device
B = Motorola Blue Chip Program Device
P = Phoenix Program
★ = First Time in Book
† = \$200 Minimum Waived

N = Key New Motorola Device
R = Key "Focus" Motorola Device

1 = Mature, Stable, High-Volume Device
2 = Moderate-Volume Device
3 = Low-Volume Device

COMMERCIAL COMPONENTS

Type No.	Grp/Description	Per Unit Sugg. Factory			
		Resale Price	Price	Order	
PC	Qty	Price	Incrmnt		
MC33560ADW	L SMART CARD READER	N	30	2.44	30 *
MC33560DW	L SMART CARD READER	N	30	1.87	30 *
MC3357P	V LINLOPWRNARWBAND FMIF	2	25	1.22	500 S P
MC3358D	B LIN DUAL DIFF INPT OP AMP	3	98	1.73	98 †
MC3358P1	B LIN DUAL DIFF INPT OP AMP	2	50	1.08	1000 †
MC3359DW	V LIN HI GAIN/LO PWR FMIF	N	38	1.98	38
MC3359DWR2	V HI GAIN/LO PWR FMIF	2	1000	2.02	1000
MC3359P	V LIN HI GAIN/LO PWR FMIF	2	20	1.98	20
MC3361BD	V LINLOPWRNARWBAND FMIF	N	48	1.13	48 S
MC3361BDR2	V LOW VOLT. IF AMPLIFIER	N	2500	1.40	2500 *S
MC3361BP	V LINLOPWRNARWBAND FMIF	N	25	.97	500 S
MC3361CD	V LOW POWER NARROW FMIF	N	48	1.12	48 S
MC3361CDR2	V LOW POWER FMIF	2	2500	1.15	2500 S
MC3361CP	V LOW POWER NARROW FMIF	N	25	1.12	500 S
MC3362DW	V LINLOPWRDL CNV FMRCVR	2	30	3.28	30 S
MC3362DWR2	V FM RECEIVER	2	1000	3.31	1000 S
MC3362P	V LINLOPWRDL CNV FMRCVR	2	15	3.10	15 S
MC3363DW	V LINLOPWRDL CNV FMRCVR	2	26	4.37	26 S
MC3363DWR2	V SINGLE CHIP RECEIVER	2	1000	4.41	1000 S
MC3367DW	V LINLO-VOLTAGE FMIF/DET	2	26	3.61	26
MC3367DWR2	V LINLO-VOLTAGE FMIF/DET	2	1000	3.66	1000
MC3371D	V FMIFIC	1	48	2.56	48 S
MC3371DR2	V FM RECEIVER IC	2	2500	2.59	2500 S
MC3371P	V FMIFIC	N	25	2.56	500 S
MC3372D	V FMIFIC	2	48	2.56	48 S
MC3372DR2	V FM NARROW BAND IF	2	2500	2.59	2500 S
MC3372P	V FMIFIC	N	25	2.56	500 S
MC3373D	L LIN REMOTE CNTRL PRE AMP	N	98	1.17	98 S P
MC3373DR2	L LIN IR RECEIVER	2	2500	1.21	2500 S P
MC3373P	L LIN REMTE CONTROL AMP-DET	2	50	1.17	1000 S P
MC3374FTB	V FM RECEIVER	N	250	2.74	250 S
MC3399DWR2	J HISIDE DRIVER SW	N	1000	2.29	1000 S
MC34C86D	N EIA422 LINE DRIVER	N	48	1.04	48
MC34C86P	N EIA422 LINE DRIVER	N	25	1.04	25
MC34C87D	N EIA422 LINE DRIVER	N	48	1.04	48
MC34C87P	N EIA422 LINE DRIVER	N	25	1.04	25
MC34001BP	B LINSNGLJFET INPT OP AMP	3	50	1.28	1000 †
MC34001P	B LINSNGLJFET INPT OP AMP	N	50	.39	1000 †
MC34002BD	B LIN DUAL JFET INPT OP AMP	3	98	1.76	98 †
MC34002BDR2	B JFET INPT OP AMP	2	2500	.73	2500 †
MC34002BP	B LIN DUAL JFET INPT OP AMP	3	50	1.76	1000 †
MC34002P	B LIN DUAL JFET INPT OP AMP	2	50	.52	1000 †
MC34004BP	B LIN QUAD JFET INPT OP AMP	2	25	.78	500 †
MC34004P	B LIN QUAD JFET INPT OP AMP	2	25	.65	500 †
MC34010FN	L LINELECTRONIC PHONE CKT	N	26	12.71	26 S P

Type No.	Grp/Description	Per Unit Sugg. Factory			
		Resale Price	Price	Order	
PC	Qty	Price	Incrmnt		
MC34010FNR2	L LINELECTRONIC PHONE CKT	2	450	12.74	450 S P
MC34010P	L LINELECTRONIC PHONE CKT	2	9	12.71	9 S P
MC34012-1D	L LIN TELEPHONE TONE RINGER	N	98	2.15	98
MC34012-1DR2	L TELEPHNTNRNGR	N	2500	2.19	2500 *
MC34012-2D	L LIN TELEPHONE TONE RINGER	N	98	2.15	98
MC34012-2DR2	L TELEPHNTNRNGR	N	2500	2.19	2500 *
MC34012-3D	L LIN TELEPHONE TONE RINGER	N	98	2.15	98
MC34012-3DR2	L LIN TELEPHONE TONE RINGER	N	98	2.19	98 *
MC34014P	L LINS PCHNTWRK W/DLRINTF	2	20	2.39	20 S P
MC34016DW	V CORDLESS TELEPH INTERFACE	N	38	1.87	38 S P
MC34016DWR2	V CORDLESS TELEPH INTERFACE	2	1000	1.91	1000 S P
MC34016P	V CORDLESS TELEPH INTERFACE	N	18	1.48	360 S P
MC34017-1D	L LIN TELEPHONE TONE RINGER	2	98	1.76	98 S P
MC34017-1DR2	L TELEPHNTNRNGR	2	2500	1.80	2500 S P
MC34017-1P	L LIN TELEPHONE TONE RINGER	2	50	1.76	1000 S P
MC34017-2D	L LIN TELEPHONE TONE RINGER	N	98	1.76	98 S P
MC34017-2DR2	L TELEPHNTNRNGR	2	2500	1.80	2500 S P
MC34017-2P	L LIN TELEPHONE TONE RINGER	2	50	1.76	1000 S P
MC34018P	L LIN VCE SWTCH SPKRPHN CKT	1	13	5.38	13 S P
MC34023P	B HI-SPDPWM CONTROLLER	N	25	5.46	500 †
MC34025DW	B HI-SPDPWM CONTROLLER	N	47	5.05	47 †
MC34025DWR2	B HI-SPDPWM CONTROLLER	2	1000	5.10	1000 †
MC34025P	B HI-SPDPWM CONTROLLER	N	25	4.86	500 †
MC3403D	B LIN QUAD DIFF INPT OP AMP	2	55	.40	55 †
MC3403DR2	B LIN QD DIFF INPT O.A. T/R	2	2500	.40	2500 †
MC3403P	B LIN QUAD DIFF INPT OP AMP	1	25	.35	500 †
MC3405P	B LIN DUAL O.A. & DUAL COMP	2	25	1.14	500 †
MC34055DW	L LAST ORDER DATE:10/20/98	2	30	16.29	30 S P
MC34055DWR2	L LAST ORDER DATE:10/20/98	2	1000	16.33	1000 S P
MC34058FTA	L LAST ORDER DATE:10/20/98	N	250	23.40	250 S P
MC34059FTA	L LAST ORDER DATE:10/20/98	N	250	26.21	1250 S P
MC34060AD	B SWTCHMD PWM CNTRL CRCT	N	55	1.87	55 †
MC34060AP	B LINSWTCHMD PWR CONT CKT	1	25	1.87	500 †
MC34063AD	B LIN PULSE WIDTH MOD	1	98	2.13	98 †
MC34063ADR2	B LIN PULSE WIDTH MOD	2	2500	2.17	2500 †
MC34063AP1	B LIN PWM CNTRL CRCT	1	50	2.13	1000 †
MC34064D-005	B LIN UNDRVOLTAG SNSNG CRCT	1	98	.92	98 †
MC34064D-5R2	B LIN UNDRVOLTAGE CRCT	2	2500	.92	2500 †
MC34064DM-005	B UNDERVOLTAGE CIRCUIT	2	2500	1.27	2500 †
MC34064P-005	B LIN UNDRVOLTAG SNSNG CRCT	1	2000	.92	2000 †
MC34064P-5RA	B LIN UNDRVOLTAG SNSNG CRCT	2	2000	.92	2000 †
MC34064P-5RP	B UNDERVOLTAGE CIRCUIT	2	2000	.92	2000 †
MC34065DW-H	B LINDL CRNT-MODE CONTRLR	2	47	2.25	47 S P †
MC34065DW-L	B LINDL CRNT-MODE CONTRLR	N	47	2.25	47 S P †
MC34065P	B LINDL CRNT-MODE CONTRLR	N	25	2.69	500 S P †

A = OSPD/Power
 B = Analog/Logic
 J = Transportation
 L = Consumer
 N = Networking
 V = Wireless

S = Proprietary Device
 B = Motorola Blue Chip Program Device
 P = Phoenix Program
 * = First Time in Book
 † = \$200 Minimum Waived

N = Key New Motorola Device
 R = Key "Focus" Motorola Device

1 = Mature, Stable, High-Volume Device
 2 = Moderate-Volume Device
 3 = Low-Volume Device

COMMERCIAL COMPONENTS

Type No.	Grp/Description	Per PC	Unit Qty	Sugg. Price	Factory Order Incrmnt	Type No.	Grp/Description	Per PC	Unit Qty	Sugg. Price	Factory Order Incrmnt
MC34065P-H	B LIN DL CRNT-MODE CONTRLR	2	25	2.25	25 S P †	MC34115DW	V LAST ORDER DATE:12/01/98	2	47	4.01	47 S
MC34065P-L	B LIN DL CRNT-MODE CONTRLR	2	25	2.25	500 S P †	MC34115P	V LAST ORDER DATE:12/01/98	2	25	3.82	500 S
MC34066P	B LIN RESONANT MD CNTRL	N	25	3.13	500 S P †	MC34118DW	L LIN SPEAKERPHONE CKT	2	26	7.35	26
MC34067DW	B RESONANT SUPPLY CNTRL	2	47	3.31	47 S P †	MC34118DWR2	L LIN SPEAKERPHONE II	2	1000	7.40	1000
MC34067DWR2	B RESONANT SUPPLY CNTRL	2	1000	3.35	1000 S P †	MC34118DWR3	L LIN SPEAKERPHONE II	2	1000	7.40	1000
MC34067P	B RESONANT SUPPLY CNTRL	2	25	3.13	500 S P †	MC34118P	L LIN SPEAKERPHONE CKT	1	13	7.35	13
MC34071AD	B LIN OP AMP SOIC	N	98	1.18	98 †	MC34119ADTB	L LIN LOW PWR AUDIO AMPLER	N	156	1.18	156 *
MC34071ADR2	B HIPER SS OP AMP	2	2500	1.23	2500 †	MC34119D	L LIN LOW PWR AUDIO AMPLFR	1	98	1.46	98
MC34071AP	B LIN DC-DC CONVERTER CKT	N	50	1.18	1000 †	MC34119DR2	L LIN SPKR PHN AMP	2	2500	1.51	2500
MC34071D	B LIN HI PRF/SNGL SPLY O.A.	2	98	.92	98 †	MC34119DTB	L LIN LOW PWR AUDIO AMPLFR	N	156	1.14	156
MC34071DR2	B HIPER SS OP AMP	2	2500	.97	2500 †	MC34119DTBEL	L LIN LOW PWR AUDIO AMPLFR	N	2000	1.23	2000
MC34071P	B LIN HI PRF/SNGL SPLY O.A.	2	50	.92	1000 †	MC34119P	L LIN LOW PWR AUDIO AMPLFR	1	50	1.46	1000
MC34072AD	B LIN OP AMP SOIC	2	98	1.38	98 †	MC34129D	L LIN HI PRF CURR MODE CONT	2	55	2.77	55 S P
MC34072ADR2	B LIN OP AMP	2	2500	1.42	2500 †	MC34129DR2	L LIN HI PERF CURR MODE CNTR	2	2500	2.81	2500 S P
MC34072AP	B LIN HI PRF/SNGL SPLY O.A.	2	50	1.38	1000 †	MC34129P	L LIN HI PRF CURR MODE CONT	1	25	2.77	500 S P
MC34072D	B LIN HI PRF/SNGL SPLY O.A.	1	98	1.14	98 †	MC34151D	B LIN HI-SPD DL MOSFT DRVR	N	98	1.76	98 †
MC34072DR2	B LIN HI PRF/SNGL SPLY O.A.	1	2500	1.18	2500 †	MC34151P	B LIN HI-SPD DL MOSFT DRVR	2	50	1.76	1000 †
MC34072P	B LIN HI PRF/SNGL SPLY O.A.	1	50	1.08	1000 †	MC34152D	B LIN HI-SPD DL MOSFT DRVR	2	98	1.76	98 †
MC34072VD	B QUAD, SNGLE & DUAL OP AMP	N	98	.92	98 †	MC34152DR2	B MOSFET DRIVER	N	2500	1.76	2500 †
MC34072VP	B QUAD, SNGLE & DUAL OP AMP	N	50	.92	1000 †	MC34152P	B LIN HI-SPD DL MOSFT DRVR	2	50	1.76	1000 †
MC34074AD	B LIN HI PRF/SNGL SPLY O.A.	2	55	1.55	55 †	MC34156FN	L INKJET PRINTER DRIVER	N	26	4.99	26
MC34074ADR2	B LIN QUAD OP AMPS	2	2500	1.74	2500 †	MC34160DW	B LIN MICROPROCESSOR VOLT REG	N	47	2.67	47 S P †
MC34074AP	B LIN HI PRF/SNGL SPLY O.A.	1	25	1.70	500 †	MC34160DWR2	B LIN MICROPROCESSOR VOLT REG	2	1000	1.94	1000 S P †
MC34074D	B LIN HI PRF/SNGL SPLY O.A.	1	55	1.55	55 †	MC34160P	B LIN MICROPROCESSOR VOLT REG	2	25	1.73	500 S P †
MC34074DR2	B LIN QUAD OP AMPS	2	2500	1.59	2500 †	MC34161D	B LIN UNIV VOLTAGE MONITOR	2	98	1.25	98 †
MC34074P	B LIN HI PRF/SNGL SPLY O.A.	1	25	1.55	500 †	MC34161DR2	B LIN UNIV VOLT MONITOR	2	2500	1.29	2500 †
MC34074VD	B QUAD, SING & DUAL OP AMP.	N	55	1.55	55 †	MC34161P	B LIN UNIV VOLTAGE MONITOR	N	50	1.25	1000 †
MC34074VP	B QUAD OP AMP	N	25	1.53	500 †	MC34163DW	B LIN POWER SW REG	2	47	3.20	47 S P †
MC34080BD	B SINGLE JFET OP AMP	2	98	1.23	98 †	MC34163DWR2	B POWER SWITCHING REGULATOR	2	1000	3.24	1000 S P †
MC34080BDR2	B SINGLE JFET OP AMP	2	2500	1.27	2500 †	MC34163P	B LIN POWER SWITCHING REG	2	25	3.02	500 S P †
MC34080BP	B SINGLE JFET OP AMP	2	50	1.23	1000 †	MC34164D-003	B MICROPWR UNDRVOLT SENSOR	2	98	1.23	98 †
MC34081BD	B SINGLE JFET OP AMP	2	98	1.12	98 †	MC34164D-005	B MICROPWR UNDRVOLT SENS	1	98	1.23	98 †
MC34081BDR2	B SINGLE JFET OP AMP	2	2500	1.16	2500 †	MC34164D-3R2	B MCRP PWR UNDR VOLT SENSOR	2	2500	1.27	2500 †
MC34081BP	B SINGLE JFET OP AMP	2	50	1.12	1000 †	MC34164D-5R2	B UNDRVOLTAGE SENSE	2	2500	1.27	2500 †
MC34082P	B LIN HI PRF JFET INPT O.A.	1	50	1.46	1000 †	MC34164DM-003	B UNDRVOLTAGE CIRCUIT	N	2500	1.31	2500 †
MC34083BP	B LIN HI PRF JFET INPT O.A.	N	50	1.57	1000 †	MC34164DM-005	B UNDRVOLTAGE CIRCUIT	N	2500	1.31	2500 †
MC34084DW	B LIN HI PRF JFET INPT O.A.	1	47	2.67	47 †	MC34164P-003	B MICROPWR UNDRVOLT SENSOR	2	2000	1.23	2000 †
MC34084DWR2	B OP AMP	2	1000	2.71	1000 †	MC34164P-005	B MICROPWR UNDRVOLT SENS	1	2000	1.23	2000 †
MC34084P	B LIN HI PRF JFET INPT O.A.	1	25	2.45	500 †	MC34164P-3RA	B UNDRVOLT SENSE	2	2000	1.27	2000 †
MC34085BDW	B LIN HI PRF JFET INPT O.A.	N	47	2.67	47 †	MC34164P-3RP	B UNDRVOLT SENSE	2	2000	1.27	2000 †
MC34085BDWR2	B LIN HI PRF JFET INPT O.A.	2	1000	2.09	1000 †	MC34164P-5RA	B UNDRVOLT SENSE	2	2000	1.27	2000 †
MC34085BP	B LIN HI PRF JFET INPT O.A.	N	25	2.45	500 †	MC34164P-5RP	B UNDRVOLT SENSE	2	2000	1.27	2000 †
MC34114DW	L SPEECH NETWORK	2	38	2.59	38 S P	MC34165DW	B LAST ORDER DATE:06/30/98	2	47	2.84	47 †
MC34114DWR2	L SPEECH NETWORK	2	1000	2.57	1000 S P	MC34165DWR2	B LAST ORDER DATE:06/30/98	2	1000	2.28	1000 †
MC34114P	L TELEPHONE SPEECH NETWORK	2	20	2.39	20 S P	MC34165P	B LAST ORDER DATE:06/30/98	2	25	2.62	500 †

A = OSPD/Power
 B = Analog/Logic
 J = Transportation
 L = Consumer
 N = Networking
 V = Wireless

S = Proprietary Device
 B = Motorola Blue Chip Program Device
 P = Phoenix Program
 * = First Time in Book
 † \$200 Minimum Waived

N = Key New Motorola Device
 R = Key "Focus" Motorola Device

1 = Mature, Stable, High-Volume Device
 2 = Moderate-Volume Device
 3 = Low-Volume Device

EFFECTIVE DATE: JANUARY 10, 1998

COMMERCIAL COMPONENTS

Type No.	Grp/Description	Per Unit Sugg. Factory				
		Resale Price	Price	Order		
PC Qty				Incrmnt		
MC34166D2TR4	B LINPWR SWITCHING REG	2	800	3.83	800	†
MC34166T	B LINPWR SWITCHING REG	1	50	4.34	50	†
MC34166TV	B 3AMP FIX FREQ DC-DC CNVRT	N	50	4.56	50	†
MC34167D2TR4	B LINPWR SWITCHING REG	2	800	3.83	800	†
MC34167T	B LINEAR PWR SWITCHING REG	N	50	4.77	50	†
MC34167TH	B LINPWR SWITCHING REG	N	50	4.77	50	†
MC34167TV	B 5AMP FIX FREQ DC/DC CNVRT	N	50	4.99	50	†
MC3418DW	V LINAUDIO CVSD	2	47	2.92	47	S
MC3418DWR2	V LINAUDIO CVSD	2	1000	2.92	1000	S
MC3418P	V LINAUDIO CVSP	2	25	2.92	25	S
MC34181D	B LINLOPWR JFET INPT O.A.	2	98	1.12	98	†
MC34181DR2	B LINOP AMP	2	2500	1.16	2500	†
MC34181P	B LINLOPWR JFET INPT O.A.	2	50	1.12	1000	†
MC34182D	B LINLOPWR JFET INPT O.A.	1	98	1.51	98	†
MC34182DR2	B LINLOPWR JFET INPT O.A.	2	2500	1.55	2500	†
MC34182P	B LINLOPWR JFET INPT O.A.	1	50	1.51	1000	†
MC34184D	B LINLOPWR JFET INPT O.A.	1	55	2.34	55	†
MC34184DR2	B LINOP AMP	2	2500	2.39	2500	†
MC34184P	B LINLOPWR JFET INPT O.A.	2	25	2.34	500	†
MC34216ADWFR2	L SPEECH CIRCUIT	2	1000	6.71	1000	S
MC34216ADWR2	L SPEECH CIRCUIT	2	1000	6.57	1000	S
MC34217D	L TELEPHONE TONERINGER	N	98	1.17	98	S P
MC34217DR2	L TELEPHONE TONERINGER	2	2500	1.17	2500	S P
MC34217P	L TELEPHONE TONERINGER	N	50	1.17	50	S P
MC3423D	B LINOVRVLTG PROTECTN CKT	N	98	.70	98	★
MC3423DR2	B OVRVLTG SENSING CRKT	2	2500	.90	2500	†
MC3423P1	B LINOVRVOLTAGE SENS GCKT	1	50	.90	1000	†
MC3425P1	B LINPWR SPLY SUPVSRV CKT	1	50	2.09	1000	†
MC34261D	B POWERFACTOR CORRECTION	N	98	1.98	98	†
MC34261P	B POWERFACTOR CORRECTION	N	50	2.13	1000	†
MC34262D	B POWERFACTOR CORRECTION	N	98	1.98	98	†
MC34262DR2	B POWERFACTOR CORRECTION	2	2500	2.60	2500	†
MC34262P	B POWERFACTOR CORRECTION	N	50	1.59	1000	†
MC34268D	B SCSI-2 REGULATOR	N	98	1.76	98	†
MC34268DR2	B SCSI-2 REGULATOR	2	2500	1.70	2500	†
MC34268DT	B SCSI-2 REGULATOR	N	75	2.26	75	†
MC34268DT-001	B SCUSIREGULATOR	N	75	2.26	75	†
MC34268DTRK	B SCSI-2 REGULATOR	N	2500	2.30	2500	†
MC34270FB	B LCD/BCKLITE DPLSY DRVR	N	250	10.66	1250	S P
MC34271FB	B LCD/BCKLITE DPLSY DRVR	N	250	12.73	1250	S P
MC3456P	B LINDUAL TIMING CIRCUIT	2	25	.41	500	†
MC3458DR2	B DLLOPWR OPAMP	2	2500	1.12	2500	†
MC3458P1	B LINDUAL DIFF INPT OP AMP	2	50	1.08	1000	†
MC3476P1	B LINLO COST PRGRMB OP AMP	2	50	.57	1000	†
MC3479P	B LIN STEPPER MOTOR DRIVER	1	25	3.15	25	†

Type No.	Grp/Description	Per Unit Sugg. Factory				
		Resale Price	Price	Order		
PC Qty				Incrmnt		
MC3488AD	B LINDLRS423 DR	2	98	1.70	98	†
MC3488AP1	B LINQUAD SNG-END LNE DRVR	2	50	1.70	1000	†
MC44002P	L CHROMA4	N	9	19.89	9	S P
MC44007P	L CHROMA4	N	9	17.20	9	S P
MC44011FN	L VDEOPROCES DECODPL	N	260	20.43	260	S P
MC44131P	L TVSTEREO SOUND PROCESSOR	N	13	8.60	13	
MC44140DW	L CMOS DELAY LINE	N	47	3.57	47	S P
MC44140P	L CMOS DELAY LINE	2	25	3.57	25	S P
MC44144D	L SUBCARRIER REFERENCE	N	98	1.64	98	S P
MC44144DR2	L SUBCARRIER REFERENCE	2	2500	1.64	2500	S P
MC44144P	L SUBCARRIER REFERENCE	N	50	1.64	1000	S P
MC44301P	L LINSYSTEM4 VIDEO I.F.	2	15	5.76	15	S P
MC44460B	L COLOR PIP	N	9	29.25	9	S P
MC44461B	L COLOR PIP	N	9	29.25	9	S P
MC44602P2	B CURRENT MODE PWM CONTROLL	N	25	1.80	25	S P
MC44603AP	B UNIVERSAL CUR.MODE CNTRLR	N	25	2.27	500	S P
MC44603P	B UNIVERSAL CUR.MODE CNTRLR	N	25	2.16	25	S P
MC44604P	B OFF LINE PWN WITH STANBY	N	25	2.99	500	S P
MC44605P	B OFF LINE PWN GREEN CONTRO	N	25	3.15	500	S P
MC44817BD	L PLL TUNING CIRCUIT	N	48	4.02	48	
MC44817BDR2	L PLL TUNING CIRCUIT	2	2500	4.02	2500	
MC44817D	L PLL TUNING CIRCUIT	N	48	3.35	48	
MC44817DR2	L PLL TUNING CIRCUIT	2	2500	3.35	2500	
MC44818D	L PLL TUNING CIRCUIT	N	48	3.35	48	
MC44818DR2	L PLL TUNING CIRCUIT	2	2500	3.35	2500	
MC44829D	L SYSTEM4 PLL TUNING CIRCUIT	N	55	3.12	55	
MC44829DR2	L SYSTEM4 PLL TUNING CIRCUIT	2	2500	3.12	2500	
MC44864M	L PLL TUNING CIRCUIT	N	40	6.97	40	
MC44864MR2	L PLL TUNING CIRCUIT	2	1000	6.97	1000	
MC4558CD	B LINDUAL WDBANDWIDTH O.A.	N	98	.61	98	†
MC4558CP1	B LINDUAL WDBANDWIDTH O.A.	1	50	.61	1000	†
MC4741CD	B LIN(QUAD MC1741) OPAMP	3	55	1.20	55	†
MC4741CDR2	B QD OPAMP	2	2500	.46	2500	†
MC4741CP	B LIN(QUAD MC1741) OPAMP	2	25	.44	500	†
MC54HCT244AJ	B IC CHIP OCTAL3-ST	3	19	3.28	380	†
MC54HCT245AJ	B OCTL3-STNONINVRT BUS TR	2	19	1.62	380	†
MC54HCT374AJ	B OCTL3-STNONVRT D-TYPE	3	19	2.93	380	†
MC54HC00AJ	B GATE NAND GATE2-I	2	25	1.22	500	†
MC54HC02AJ	B NORQUAD2-INPUT	2	25	1.22	500	†
MC54HC04AJ	B HEX INVERTER	2	25	1.24	500	†
MC54HC08AJ	B QUAD2 INPUT & GATE	2	25	1.24	500	†
MC54HC132AJ	B QD2-INPT NAND GATE W/SCH	3	25	2.48	500	†
MC54HC138AJ	B DECODER/DEMULPLX10F8	2	25	1.31	500	†
MC54HC14AJ	B HEX SCHMITT INVERTER	2	25	1.26	500	†
MC54HC15AJ	B HSL1OF16 DECODER/DEMUX	2	15	2.52	15	†

A = OSPD/Power
 B = Analog/Logic
 J = Transportation
 L = Consumer
 N = Networking
 V = Wireless

S = Proprietary Device
 B = Motorola Blue Chip Program Device
 P = Phoenix Program
 ★ = First Time in Book
 † \$200 Minimum Waived

N = Key New Motorola Device
 R = Key "Focus" Motorola Device

1 = Mature, Stable, High-Volume Device
 2 = Moderate-Volume Device
 3 = Low-Volume Device

COMMERCIAL COMPONENTS

Type No.	Grp/Description	Per Unit Sugg.		Factory Order	PC Qty	Price	Incrrmnt	Type No.	Grp/Description	Per Unit Sugg.		Factory Order	PC Qty	Price	Incrrmnt
		Resale	Price							Resale	Price				
MC54HC157AJ	B DTASELCTOR/MLTIPLX2-IQ	3	25	2.73	500	†	MC68EC000FN16	L 8/16/32BIT EMBEDDED CTRL	2	18	8.30	18	S	B	
MC54HC161AJ	B CNTR,BINRY,4-BASYNCHR	3	25	2.79	500	†	MC68EC000FN20	L 8/16/32BIT EMBEDDED CTRL	2	18	10.04	18	B		
MC54HC163AJ	B COUNTER,DECADE,BCD	3	25	2.76	500	†	MC68EC000FN8	L 8/16/32-BIT EMBEDDED CTRL	1	18	4.32	18	S	B	
MC54HC165J	B HSL8BIT P/SOS/R	3	25	3.04	500	†	MC68EC000FU10	L 8/16/32BIT EMBEDDED CTAL	2	84	5.34	84	S	B	
MC54HC240AJ	B HSL OCT3-SINV BFR/DRVR	3	19	3.82	380	†	MC68EC000FU12	L 8/16/32BIT EMBEDDED CTAL	2	84	6.21	84	S	B	
MC54HC244AJ	B HSL QD3-SN-INV BFR/DRVR	2	19	2.25	380	†	MC68EC000FU16	L 8/16/32BIT EMBEDDED CTAL	2	84	7.59	84	S	B	
MC54HC245AJ	B HSL OCT3-SN-INV BUSTRAN	2	19	2.36	380	†	MC68EC000FU20	L 8/16/32BIT EMBEDDED CONT	N	84	9.67	84	S	B	
MC54HC259J	B HSL8-BIT ADLATCH1 OF8	3	25	3.04	500	†	MC68EC000FU8	L 8/1632BIT EMBEDDED CTAL	2	84	4.11	84	S	B	
MC54HC27J	B HSL TRIPLE3-INORGATE	3	25	2.59	500	†	MC68EC020FG16	L 32-BIT EMBEDDED CTRL PQFP	2	66	14.15	66	S	B	
MC54HC273AJ	B OCTLD-TYPE FLIP/FLOP	3	19	3.64	380	†	MC68EC020FG25	L 32-BIT EMBEDDED CTRL PQFP	1	66	16.77	66	S	B	
MC54HC32AJ	B 2-I QUAD ORGATE	2	25	1.24	500	†	MC68EC020RP16	L 32-BIT EMBEDDED CTRL PPGA	1	13	37.11	13	S	B	
MC54HC367J	B HSL HEX3-STNONINV.BUF	3	25	3.12	500	†	MC68EC020RP25	L 32-BIT EMBEDDED CTRL PPGA	2	13	44.32	13	S	B	
MC54HC373AJ	B OCT TRANSP L TCH3-ST	3	19	3.79	380	†	MC68EC030FE25C	L 32BIT EMBEDD CTRL,NOMMU	1	36	26.49	36	S	B	
MC54HC374AJ	B FLIP-FLOP,OCTD,3-ST	2	19	2.29	380	†	MC68EC030FE40C	L 32BIT EMBEDD CTRL,NOMMU	1	36	36.74	36	B		
MC54HC390J	B HSL DUAL4-STAGE BIN CNTR	3	25	3.14	500	†	MC68EC030PV25C	L LAST ORDER DATE:07/01/98	N	60	19.74	60			
MC54HC393J	B HSL DUAL4-STAGE BIN CNTR	2	25	1.60	500	†	MC68EC030RP25B	L 32BIT EMBEDD CTRL,NOMMU	1	1	42.50	1	S		
MC54HC4051J	B HSL8-CHANALOG MUX/DEMUX	2	25	2.20	500	†	MC68EC030RP25C	L 32BIT EMBEDD CTRL,NOMMU	N	14	40.37	14	B		
MC54HC4053J	B HSL TRIPLE2-CHANAMUX	2	25	2.12	500	†	MC68EC030RP40C	L 32BIT EMBEDD CTRL,NOMMU	N	14	54.13	14	B		
MC54HC4066J	B HSL QD ANALOG SWITCH MUX	3	25	3.11	500	†	MC68EC040FE20	L 32BIT MPU EMBEDDED	N	24	58.54	24	B		
MC54HC4538AJ	B MULTIVI PRECIS MONSTB DUA	3	25	2.90	500	†	MC68EC040FE25	L 32BIT MPU EMBEDDED	1	24	58.54	24	B		
MC54HC573AJ	B OCTL3-ST,NONINVRT-D-TYP	3	19	3.79	380	†	MC68EC040FE33	L 32BIT MPU EMBEDDED	1	24	86.26	24	B		
MC54HC595AJ	B SHIFT REG.3-STATE	2	25	1.89	500	†	MC68EC040FE40	L 32BIT MPU EMBEDDED	N	24	95.68	24	B		
MC54HC646J	B HSL OCTAL3-ST NIBUSTRAN	3	15	12.97	15	†	MC68EC040RC20	L 32BIT MPU EMBEDDED	N	10	87.21	10			
MC54HC688J	B HSL8-BIT EQUALITY COMPAR	3	19	4.09	380	†	MC68EC040RC25	L 32BIT MPU EMBEDDED	1	10	87.21	10			
MC54HC74AJ	B FFD TYPE DUAL	2	25	1.28	500	†	MC68EC040RC33	L 32BIT MPU EMBEDDED	1	10	123.00	10			
MC68A00CP	J 8 BIT MPU 1.5MHZ EXTEMP	N	9	7.53	9		MC68EC040RC40	L 32BIT MPU EMBEDDED	N	10	181.66	10			
MC68B00P	J 8 BIT MPU,2.0MHZ	2	9	6.67	9		MC68EN360EM25C	N 68360W/ETHERNET	N	24	48.55	24	S	B	
MC68B03P	J 8 BIT MPU,2MHZ	1	9	7.33	9		MC68EN360EM25VC	N 68360W/ETHERNET	N	24	57.48	24	S	B	
MC68B08P	J 8 BIT MPU + CLOCK	N	1	5.67	1		MC68EN360EM33C	N 68360W/ETHERNET	N	24	53.01	24	S	B	
MC68B09CP	J 8 BIT MCU	1	9	5.93	9		MC68EN360FE25C	N PLEASE USE EMPKG.	1	24	54.50	24	S		
MC68B09EP	J 8-BIT MPU W/EXTERNAL CLCK	1	9	6.13	9		MC68EN360FE25VC	N PLEASE USE EMPKG.	N	24	64.40	24	S		
MC68B21CP	J 8 BIT MCU	1	9	4.27	9		MC68EN360FE33C	N PLEASE USE EMPKG.	1	24	59.45	24	S		
MC68B40CP	J 8 BIT MCU	1	13	3.40	13		MC68EN360RC25C	N QUICC W/ETHERNET	1	1	89.08	1	S		
MC68B44P	J DMAC PLASTIC 2.0MHZ	2	9	10.20	9		MC68EN360RC33C	N QUICC W/ETHERNET	N	1	97.48	1	S		
MC68B45P	J LAST ORDER DATE:06/10/98	1	9	4.00	9		MC68EN360ZP25C	N QUICC	N	44	48.55	44	S	B	
MC68B488P	J LAST ORDER DATE:06/10/98	1	9	16.20	9		MC68EN360ZP25VC	N QUICC	N	44	57.48	44	S	B	
MC68B50CP	J ACIA	1	15	3.80	15		MC68EN360ZP33C	N 68360W/ETHERNET	N	44	53.01	44	S	B	
MC68B52P	J SSSA, PLASTIC 2.0MHZ	2	15	6.19	15		MC68HCB34FN	J LAST ORDER DATE:06/10/98	N	26	5.71	26	S		
MC68B701S	J 8BIT EPROM MCU 2K2.0MHZ	N	9	25.91	9	S	MC68HCP11A0CFN3	J 8 BIT MCU,256RAM,COP,A/D	N	23	7.71	23	★	B	
MC68CK331CFC16	J 32BIT HCMOS WIREBOND	N	36	14.38	36	★	B	MC68HCP11A0FN	J 8 BIT MCU,256RAM,COP,A/D	1	23	5.94	23	B	
MC68CK331CFC16B1	J 32BIT HCMOS WIREBOND	N	180	13.83	180	★	B	MC68HCP11A0FN2	J I/C MONOLITHIC MCU	N	450	7.75	450	★	B
MC68CK331CPV16	J 32BIT HCMOS WIREBOND	N	60	12.18	60	★	B	MC68HCP11A0FU	J 8BIT MCU W/ O ROM,EEPROM	N	50	7.50	50	★	B
MC68CK331CPV16B1	J 32BIT HCMOS WIREBOND	N	300	11.63	300	★	B	MC68HCP11A0P	J 8-BIT MCU,256RAM,COP,A/D	2	7	7.53	7	B	
MC68EC000FN10	L 8/16/32BIT EMBEDDED CTRL	2	18	5.33	18	S	B	MC68HCP11A1CFN3	J 8-BIT MCU, RAM, EE, COP, A/D	2	23	6.86	23	B	
MC68EC000FN12	L 8/16/32BIT EMBEDDED CTRL	2	18	6.59	18	S	B	MC68HCP11A1FN	J 8-BIT MCU, RAM, EE, COP, A/D	1	23	6.13	23	B	

A = OSPD/Power
 B = Analog/Logic
 J = Transportation
 L = Consumer
 N = Networking
 V = Wireless

S = Proprietary Device
 B = Motorola Blue Chip Program Device
 P = Phoenix Program
 ★ = First Time in Book
 † \$200 Minimum Waived

N = Key New Motorola Device
 R = Key "Focus" Motorola Device

1 = Mature, Stable, High-Volume Device
 2 = Moderate-Volume Device
 3 = Low-Volume Device

COMMERCIAL COMPONENTS

Type No.	Grp/Description	Per Unit Sugg.		Factory Order	Incrmnt
		Resale Price	Price		
MC68HCP11A1FNR2	J 8-BIT MCU	N	450	6.33	450 ★ B
MC68HCP11A1P	J 8-BIT MCU, RAM, EE, COP, A/D	2	7	7.72	7 B
MC68HCP11E1FNR2	J 8-BIT MCU	N	450	6.67	450 ★ B
MC68HCP11E1VFN2	J TSCS	N	23	6.79	23 ★ B
MC68HC000FN10	L 16BIT MPU HCMOS10MHZ PLCC	1	1	4.03	18
MC68HC000FN12	L 16BIT MPU HCMOS12MHZ PLCC	1	1	4.79	18
MC68HC000FN16	L 16-BIT MPU HCMOS16MHZ	1	1	7.01	18
MC68HC000FN20	L 16BIT MPU HCMOS20MHZ	N	1	8.77	18 S
MC68HC000FN8	L 16BIT MPU HCMOS8MHZ PLCC	1	1	3.30	18
MC68HC000RC10	L 16BIT MPU HCMOS10MHZ PGA	N	21	34.37	21
MC68HC000RC12	L 16BIT MPU HCMOS12MHZ PGA	N	21	35.97	21
MC68HC000RC16	L 16BIT MPU HCMOS16MHZ PGA	N	21	37.58	21
MC68HC000RC8	L 16BIT MPU HCMOS8MHZ PGA	N	21	21.95	21
MC68HC000R10	L LAST ORDER DATE:07/31/98	N	21	36.17	21
MC68HC000R12	L LAST ORDER DATE:07/31/98	N	21	37.87	21
MC68HC000R8	L LAST ORDER DATE:07/31/98	N	21	23.11	21
MC68HC05C0CB	J 8BIT MCU	N	13	2.15	13 B
MC68HC05C0CFN	J 8BIT MCU	N	26	2.15	26 B
MC68HC05C0CP	J 8BIT MCU	N	9	2.15	9 B
MC68HC11A0CFN3	J 8-BIT MCU, 768RAM, A/D, 3MHZ	1	23	6.65	23 B
MC68HC11A0FN	J 8-BIT MCU, 256RAM, A/D, 2MHZ	1	23	5.94	23 B
MC68HC11A0FU	J 8BIT MPU NO ROM & EEPROM	2	50	5.94	50 B
MC68HC11A0P	J 8-BIT MCU, 256RAM, A/D, 2MHZ	1	7	7.53	7 B
MC68HC11A0VP	J 8-BIT MCU	N	7	7.91	7 ★ B
MC68HC11A1CFN3	J 8-BIT MCU, 256RAM, A/D, EE	1	23	6.86	23 B
MC68HC11A1CFU3	J MCU-3MHZ DEVICE	N	500	6.85	500 ★ B
MC68HC11A1CP3	J 8-BIT MCU, 256RAM, A/D, EE	N	7	8.64	7 B
MC68HC11A1FN	J 8-BIT MCU, 256RAM, A/D, EE	1	23	6.13	23 B
MC68HC11A1FNR2	J 8-BIT MCU	N	450	6.33	450 ★ B
MC68HC11A1FU	J I/C MONOLITHIC 8 BIT MCU	N	50	6.12	50 B
MC68HC11A1MFN	J 8-BIT MCU	N	24	6.75	24 ★ B
MC68HC11A1MP	J 8-BIT MCU	N	7	8.49	7 ★ B
MC68HC11A1P	J 8-BIT MCU, 256RAM, A/D, EE	1	7	7.72	7 B
MC68HC11A1VFN	J 8-BIT MCU	N	23	6.43	23 ★ B
MC68HC11A1VP	J 8-BIT MCU	N	7	8.11	7 ★ B
MC68HC11A8P1	J 8-BIT MCU	N	7	6.36	7 ★ B
MC68HC11C0CFU2	J CMSD	N	500	6.47	500 ★ B
MC68HC11C0CFU3	J CMSD	N	500	7.24	500 ★ B
MC68HC11D0CFB3	J 8-BIT MCU, 192RAM, 3MHZ	N	480	3.36	480 ★ B
MC68HC11D0CFN2	J 8-BIT MCU	N	26	3.34	26 B
MC68HC11D0CFN3	J 8-BIT MCU, 192RAM, 3MHZ	1	26	3.74	26 B
MC68HC11D0CP2	J 8-BIT MCU	N	9	3.48	9 B
MC68HC11D0CP3	J 8-BIT MCU, 192RAM, 3MHZ	2	9	3.89	9 B
MC68HC11D0FB	J 8-BIT MCU, 192RAM, 2MHZ	2	480	3.00	480 B
MC68HC11D0FN	J 8-BIT MCU, 192RAM, 2MHZ	1	26	3.34	26 B

Type No.	Grp/Description	Per Unit Sugg.		Factory Order	Incrmnt
		Resale Price	Price		
MC68HC11D0FNR2	J MPG MCU	N	450	3.49	450 ★ B
MC68HC11D0P	J 8-BIT MCU, 192RAM, 2MHZ	1	9	3.48	9 B
MC68HC11ED0CFB2	J 8-BIT MCU, 512RAM, 2MHZ	N	480	3.63	96 B
MC68HC11ED0CFB3	J MCU	N	480	4.06	96 B
MC68HC11ED0CFN2	J 8-BIT MCU, 512RAM, 2MHZ	2	26	4.05	26 B
MC68HC11ED0CFN3	J MCU	N	26	4.54	26 B
MC68HC11ED0CP2	J 8-BIT MCU, 512RAM, 2MHZ	2	9	4.22	9 B
MC68HC11E0CFN2	J TSCS	N	23	6.28	23 ★ B
MC68HC11E0CFN2R2	J TSCS	N	450	6.48	450 ★
MC68HC11E0CFN3	J 8-BIT MCU, 512RAM, A/D, 3MHZ	N	23	7.03	23 B
MC68HC11E0FU	J 8BIT MPU W/O ROM W/O EE	N	50	6.27	50 ★ B
MC68HC11E0MFN2	J 8BIT E9MINUS ROM&EEPROM	N	23	6.91	23 ★ B
MC68HC11E0VFN2	J 8BIT E9MINUS ROM&EEPROM	N	23	6.59	23 ★ B
MC68HC11E0VFN3	J 8BIT E9MINUS ROM&EEPROM	N	23	7.39	23 ★ B
MC68HC11E1CFN3	J 8-BIT MCU, 512RAM, A/D, EE	1	23	7.24	23 B
MC68HC11E1CFU3	J MCU-3MHZ DEVICE	N	500	7.23	50 ★ B
MC68HC11E1FU	J 8BIT MCU WITH CSTMER ROM	N	50	6.46	50 ★ B
MC68HC11E9BCFN2	J 8-BIT MCU	N	23	7.02	23 B
MC68HC11F1CFN3	J 8-BIT MCU, 1KRAM, 512EE, A/D	1	18	7.76	18 B
MC68HC11F1CFN3R2	J MCU	N	250	7.96	250 ★ B
MC68HC11F1CFN4	J 8-BIT MCU, 1KRAM, 512EE, A/D	1	18	8.69	18 B
MC68HC11F1CPU3	J 8-BIT MCU	N	84	7.11	84 B
MC68HC11F1CPU4	J 8-BIT MCU	N	84	7.97	84 B
MC68HC11F1FN	J MPG8-BIT MCU	2	18	12.57	18 B
MC68HC11F1FNR2	J 8-BIT MCU	N	250	7.96	250 ★ B
MC68HC11KA0CFN3	J 8-BIT MCU, 768RAM, A/D, 3MHZ	N	18	9.04	18 B
MC68HC11KA0CFN4	J 8-BIT MCU, 768RAM, A/D, 4MHZ	N	18	10.13	18 B
MC68HC11KA1CFN3	J 8-BIT MCU, 768RAM, A/D, EE	N	18	9.32	18 B
MC68HC11KA1CFN4	J 8-BIT MCU, 768RAM, A/D, EE	N	18	10.43	18 B
MC68HC11KA2BCFN3	J MCU-HI PERF MCU BUFF ROM	N	18	9.76	18 B
MC68HC11KA4BCFN3	J 8-BIT MCU, 24K EPROM, RAM	N	18	8.13	18 B
MC68HC11KW1CPU4	J 8-BIT MCU, 768RAM, 640EEPR	N	450	12.89	450 B
MC68HC11K0CFN3	J 8-BIT MCU, 768RAM, A/D, 3MHZ	N	15	9.98	15 B
MC68HC11K0CFN4	J 8-BIT MCU, 768RAM, A/D, 4MHZ	N	15	11.17	15 B
MC68HC11K1CFN3	J 8-BIT MCU, 768RAM, A/D, EE	2	15	10.31	15 B
MC68HC11K1CFN4	J 8-BIT MCU, 768RAM, A/D, EE	2	15	11.54	15 B
MC68HC11L0CFN2	J 8-BIT MCU, 512RAM, A/D, 2MHZ	N	18	8.11	18 B
MC68HC11L0CFU3	J 8BIT MCU W/O ROM EEPROM	N	50	8.00	50 ★ B
MC68HC11L1CFN2	J 8-BIT MCU, 512RAM, A/D, EE	N	18	8.27	18 B
MC68HC11L1CFU2	J MCU	N	500	7.31	500 ★ B
MC68HC11L1CFU3	J 8BIT MCU W/O ROM W/EEPROM	N	50	8.18	50 ★ B
MC68HC11P1CFN3	J MCU	N	15	13.09	15 B
MC68HC11P1CFN4	J MCU	N	15	15.37	15 B
MC68HC16S2CPU20	J 8BIT MCU	N	84	6.43	84 ★ B
MC68HC16V1CPU20	J MCU-16 BIT, GPT, 100 TQFP	N	84	7.94	84 B

A = OSPD/Power
 B = Analog/Logic
 J = Transportation
 L = Consumer
 N = Networking
 V = Wireless

S = Proprietary Device
 B = Motorola Blue Chip Program Device
 P = Phoenix Program
 ★ = First Time in Book
 † \$200 Minimum Waived

N = Key New Motorola Device
 R = Key "Focus" Motorola Device

1 = Mature, Stable, High-Volume Device
 2 = Moderate-Volume Device
 3 = Low-Volume Device

COMMERCIAL COMPONENTS

Type No.	Grp/Description	Per PC	Unit Qty	Sugg. Resale Price	Factory Order Price	Order Incrmnt	Type No.	Grp/Description	Per PC	Unit Qty	Sugg. Resale Price	Factory Order Price	Order Incrmnt
MC68HC16Z1CFC16	J 16BIT MCU,RAM,10BITA/D	1	36	11.38	36	B	MC68HC705L16FU	L 8-BIT MCU WITH EPROM	N	50	14.51	50	B
MC68HC16Z1CFC20	J AMCU	N	36	11.95	36	B	MC68HC705L5FU	L 8BIT MCU WITH CSTMER ROM	1	50	7.95	50	B
MC68HC16Z1CFC25	J 16BIT MCU,RAM,10BITA/D	N	36	12.52	36	B	MC68HC705MC4CDW	J CSIC MCU	N	26	6.95	26 *	B
MC68HC16Z1CPV16	J 16-BITMCU,RAM,10BITA/D	N	60	9.18	60	B	MC68HC705MC4CP	J CSIC MCU	N	13	6.95	13 *	B
MC68HC16Z1CPV20	J 16 BIT MCU,RAM,10BITA/D	N	60	9.64	60	B	MC68HC705P6CDW	J 8-BIT MCU4K EPR-176 RAM	1	26	5.95	26	B
MC68HC16Z1CPV25	J AMCU	N	60	10.10	60	B	MC68HC705P6CP	J 8-BIT MCU4K EPR-176 RAM	1	13	5.95	13	B
MC68HC16Z2BCFC16	J AMCU16BITMCU2KSRAM	N	36	16.82	36	B	MC68HC705P6CS	J 8-BIT MCU4K EPR-176 RAM	N	13	31.59	13	S
MC68HC16Z2BCFC20	J AMCU16BIT2KSRAM	N	36	18.27	36	B	MC68HC705P9CDW	J 8-BIT MCU + RAM + 2K EPR	1	26	2.95	26	B
MC68HC16Z2BCPV16	J AMCU16BITMCU2KSRAM	N	60	14.62	60	B	MC68HC705P9CP	J 8-BIT MCU + RAM + 2K EPR	1	13	2.95	13	B
MC68HC16Z2BCPV20	J AMCU16BIT2KSRAM	N	60	15.73	60	B	MC68HC705P9CS	J 8-BIT MCU + RAM + 16KEPR	N	13	31.59	13	S
MC68HC24FN	J HC11 PORT REPLACEMENT	1	26	8.80	26	S	MC68HC705SR3CB	L 8BIT MCU	N	13	6.75	1	
MC68HC24P	J HC11 PORT REPLACEMENT	2	9	6.59	9	S	MC68HC705SR3CFB	L 8BIT MCU	N	50	6.75	1	
MC68HC68T1DW	L CMOS SERIAL REAL-TIME CLK	1	47	5.05	47		MC68HC705SR3CP	L 8BIT MCU	N	9	6.75	9	
MC68HC68T1DWR2	L SERIAL REAL TIME CLOCK	2	1000	5.16	1000		MC68HC711D3CFB2	L 8-BIT OTP,192RAM,2MHZ	1	480	6.23	480	B
MC68HC68T1P	L CMOS SERIAL REAL-TIME CLK	1	25	5.05	25		MC68HC711D3CFN2	J 8-BIT OTP,192RAM,2MHZ	1	26	5.95	26	B
MC68HC705BD3B	L 8 BIT MCU	N	13	10.00	1		MC68HC711D3CFN3	J 8-BIT OTP,192RAM,3MHZ	2	26	6.66	26	B
MC68HC705BD3P	L 8 BIT MCU	N	9	10.00	9		MC68HC711D3CP2	J 8-BIT OTP,192RAM,2MHZ	1	9	6.19	9	B
MC68HC705B16CB	J HC05 CORE +RAM,EPR,EEPR	N	9	7.95	9	B	MC68HC711D3CS2	J 8-BIT EPROM,192RAM,2MHZ	2	9	16.16	9	B
MC68HC705B16CFN	J HC05 CORE +RAM,EPR,EEPR	1	23	7.95	23	B	MC68HC711E20CFN2	J MPGAMCU	N	23	14.46	23	B
MC68HC705B16CFU	J HC05 CORE +RAM,EPR,EEPR	N	1	7.95	1	B	MC68HC711E20CFN3	J MPGAMCU	N	23	16.20	23 *	B
MC68HC705B5CB	L 8BIT MCU6K EPR176BT RAM	N	9	5.95	9	B	MC68HC711E20M2FN2	J MPGAMCU	N	23	15.90	23 *	B
MC68HC705B5CFN	L 8BIT MCU6K EPR176BT RAM	1	23	5.95	23	B	MC68HC711E20M3FN3	J MPGAMCU	N	23	17.81	23 *	B
MC68HC705C4ACB	L HCO5 CORE +4K RAM + EPR	N	13	4.45	13	B	MC68HC711E20VFN2	J MPGAMCU	N	23	15.18	23 *	B
MC68HC705C4ACFB	L HCO5 CORE +4K RAM + EPR	N	50	4.45	50	B	MC68HC711E20VFN3	J MPGAMCU	N	23	17.00	23 *	B
MC68HC705C4ACFN	L HCO5 CORE +4K RAM + EPR	1	26	4.45	26	B	MC68HC711E9CFN2	J 8-BIT OTP,512RAM,A/D,EE	1	23	10.57	23	B
MC68HC705C4ACP	L HCO5 CORE +4K RAM + EPR	1	9	4.45	9	B	MC68HC711E9CFN3	J 8-BIT OTP,512RAM,A/D,EE	1	23	11.84	23	B
MC68HC705C8ACB	L HCO5 CORE +8K RAM + EPR	N	13	4.95	13	B	MC68HC711E9CFU2	J 8-BIT OTP,512RAM,A/D,EE	N	500	9.58	50	B
MC68HC705C8ACFB	L HCO5 CORE +8K RAM + EPR	1	96	4.95	96	B	MC68HC711E9M2FN2	J 8-BIT AMCU	N	23	19.06	23 *	B
MC68HC705C8ACFN	L HCO5 CORE +8K RAM + EPR	1	26	4.95	26	B	MC68HC711E9VFN2	J 8-BIT AMCU	N	23	11.09	23 *	B
MC68HC705C8ACP	L HCO5 CORE +8K RAM + EPR	1	9	4.95	9	B	MC68HC711KA2CFN3	J AMCU-8BIT W/32K EPROM	N	18	18.28	18	B
MC68HC705C8ACS	L HCO5 CORE +8K RAM + EPR	1	9	44.22	9		MC68HC711KA2CFN4	J AMCU-8BIT W/32K EPROM	N	18	20.47	18	B
MC68HC705C9ACB	J CSIC MCU	N	13	5.95	13	B	MC68HC711K4CFN3	J AMCU	N	15	16.80	15	B
MC68HC705C9ACFB	J CSIC MCU	N	50	5.95	50	B	MC68HC711K4CFN4	J AMCU	N	15	18.82	15	B
MC68HC705C9ACFN	J CSIC MCU	N	26	5.95	26	B	MC68HC711L6CFN2	J 8-BIT OTP,512RAM,A/D,EE	N	18	13.49	18	B
MC68HC705C9ACP	J CSIC MCU	N	9	5.95	9	B	MC68HC711L6CFU2	J 8-BIT AMCU	N	500	11.92	500 *	B
MC68HC705G4CFU	L 8-BIT MCU WITH OTP ROM	N	50	21.00	50		MC68HC711L6CFU3	J 8BIT MCU W/BLANK EPROM	N	50	13.35	50 *	B
MC68HC705J1ACDW	L HCO5 CORE+1.2K RAM + EPR	1	38	1.27	38	B	MC68HC711P2CFN3	J AMCU	N	15	26.70	15	B
MC68HC705J1ACP	L HCO5 CORE+1.2K RAM + EPR	1	18	1.27	18	B	MC68HC711P2CFN4	J AMCU	N	15	29.90	15	B
MC68HC705J1ACS	L HCO5 CORE+1.2K RAM + EPR	N	19	25.01	19		MC68HC811E2CFN2	J TSCS	N	23	7.86	23 *	B
MC68HC705J2CDW	L 8-BIT MCU + RAM + 2K EPR	1	38	4.85	38	B	MC68HC811E2CP2	J TSCS	N	7	9.94	7 *	B
MC68HC705J2CP	L 8-BIT MCU + RAM + 2K EPR	1	20	4.95	20	B	MC68HC811E2FN	J 8-BIT MCU,2KEE,A/D,256RAM	1	23	7.86	23	B
MC68HC705J2CS	L 8-BIT MCU + RAM + 2K EPR	2	19	31.59	19	S	MC68HC811E2M2FN	J MCU WITH 2K EEPROM	N	23	8.65	23 *	B
MC68HC705K1CDW	J 8-BIT MCU + RAM +.5K EPR	1	47	2.75	47	B	MC68HC811E2M2FN2	J TSCS	N	23	8.65	23 *	B
MC68HC705K1CP	J 8-BIT MCU + RAM +.5K EPR	1	25	2.75	25	B	MC68HC811E2P	J 8-BIT MCU,2KEE,A/D,256RAM	1	7	9.55	7	B
MC68HC705K1CS	J 8-BIT MCU + RAM +.5K EPR	N	25	31.59	25		MC68HC811E2VFN	J MCU WITH 2K EEPROM	N	23	8.26	23 *	B

A = OSPD/Power
 B = Analog/Logic
 J = Transportation
 L = Consumer
 N = Networking
 V = Wireless

S = Proprietary Device
 B = Motorola Blue Chip Program Device
 P = Phoenix Program
 * = First Time in Book
 † = \$200 Minimum Waived

N = Key New Motorola Device
 R = Key "Focus" Motorola Device

1 = Mature, Stable, High-Volume Device
 2 = Moderate-Volume Device
 3 = Low-Volume Device

COMMERCIAL COMPONENTS

Type No.	Grp/Description	Per Unit Sugg.		Factory Order	Incrmnt
		Resale Price	Price		
MC68HC811E2VFN2	J 8-BIT MCU W/2K EEPROM	N	23	8.26	23 ★ B
MC68HC916R1CFC16	J 16BIT W/50K FLASH EEPROM	N	36	30.99	36 ★ B
MC68HRC705J1ACDW	L CSIC MCU	N	38	1.27	38 B
MC68HRC705J1ACP	L CSIC MCU	N	18	1.27	18 B
MC68HSC705C8ACB	L CSIC MCU	N	13	5.44	13 B
MC68HSC705C8ACFB	L CSIC MCU	N	50	6.88	50
MC68HSC705C8ACFN	L CSIC MCU	N	26	5.44	26 B
MC68HSC705C8ACP	L CSIC MCU	N	9	5.44	9 B
MC68HSC705J1ACDW	L CSIC MCU	N	38	1.40	38 B
MC68LC040FE20	L 32BIT MPU EMBEDDED	N	24	103.11	24 B
MC68LC040FE25	L 32BIT MPU EMBEDDED	N	24	103.11	24 B
MC68LC040FE33	L 32BIT MPU EMBEDDED	N	24	119.10	24 B
MC68LC040FE40	L 32BIT MPU EMBEDDED	N	24	151.09	24 B
MC68LC040RC20	L 32BIT MPU EMBEDDED	N	10	118.04	10
MC68LC040RC25	L 32BIT MPU EMBEDDED	N	10	118.04	10
MC68LC040RC33	L 32BIT MPU EMBEDDED	N	10	139.47	10
MC68LC040RC40	L 32BIT MPU EMBEDDED	N	10	165.63	10
MC68LK332ACFC16	J 32BIT,MCU,2KRAM,TPU,QSM	N	36	16.02	36 ★ B
MC68LK332ACPV16	J 32BIT,MCU,2KRAM,TPU,QSM	N	60	13.83	60 ★ B
MC68LK332GFCFC16	J 32BIT,2KRAM,TPU,QSM	N	36	16.02	36 ★ B
MC68LK332GCPV16	J 32BIT,MCU,2KRAM,TPU,QSM	N	60	13.83	60 ★ B
MC68L11A0FN2	J 8-BIT MCU,256RAM,A/D,LVDC	N	23	6.82	23 B
MC68L11A1FN2	J 8-BIT MCU,RAM,EE,A/D,LVDC	N	23	7.04	23 B
MC68L11A1FU2	J AMCU	N	500	7.03	500 ★ B
MC68L11D0FB2	J AMCU	N	480	3.58	480 ★ B
MC68L11D0FN2	J 8-BIT MCU,192RAM,LVDC	N	26	3.83	26 B
MC68L11D0P2	J 8-BIT MCU,192RAM,LVDC	N	9	4.00	9 B
MC68L11E0FN2	J 8-BIT MCU,512RAM,A/D,LVDC	N	23	7.22	23 B
MC68L11E0FU2	J AMCU	N	500	7.20	500 ★ B
MC68L11E1FN2	J 8-BIT MCU,RAM,EE,A/D,LVDC	N	23	7.43	23 B
MC68L11F1FN3	J 8-BIT MCU,RAM,EE,A/D,LVDC	N	18	8.92	18 ★ B
MC68L11K0FN3	J AMCU	N	15	11.47	15 ★ B
MC68L11K1FN3	J AMCU	N	15	11.84	15 ★ B
MC68MH360EM25E	N QUICC	N	24	52.55	24 S B
MC68MH360EM25VE	N HIGH END	N	2	63.28	24 S B
MC68MH360EM33E	N HIGH END	N	24	57.91	24 S B
MC68MH360FE25E	N PLEASE USE EMPKG.	N	24	59.50	24 S
MC68MH360FE25VE	N PLEASE USE EMPKG.	N	24	71.40	24 S
MC68MH360FE33E	N PLEASE USE EMPKG.	1	24	65.45	24 S
MC68MH360RC25E	N QUICC32	N	1	88.65	1 S
MC68MH360RC33E	N QUICC32	N	1	97.52	1 S
MC68MH360ZP25E	N QUICC32	N	44	52.55	44 S B
MC68MH360ZP25VE	N QUICC	N	44	63.28	44 ★ S B
MC68MH360ZP33E	N MULTIHDL QUICC32	N	44	57.91	44 S B
MC68SEC000FU10	L 8/16/32BIT EMBEDDED CONTL	N	84	4.66	84 B

Type No.	Grp/Description	Per Unit Sugg.		Factory Order	Incrmnt
		Resale Price	Price		
MC68SEC000FU16	L 8/16/32BIT EMBEDDED CONTL	N	84	6.24	84 B
MC68SEC000FU20	L 8/16/32BIT EMBEDDED CONTL	N	84	7.82	84 B
MC68SEC811E2FN	J 8-BIT MCU,2KEE,SECURED	2	23	10.40	23 B
MC68SEC811E2P	J 8-BIT MCU,2KEE,SECURED	N	7	12.19	7 B
MC68S711E9CFN2	J AMCU	N	23	13.21	23 ★ B
MC6802P	J 8BIT MPU W/CLK/RAM PLAS	1	9	5.27	9
MC68020FC16E	L 32-BIT MPU16MHZ PQFP	2	36	29.23	36 S B
MC68020FC20E	L 32-BIT MPU20MHZ PQFP	2	36	34.72	36 S B
MC68020FC25E	L 32-BIT MPU25MHZ PQFP	2	36	38.36	36 S B
MC68020FC33E	L 32-BIT MPU33MHZ PQFP	2	36	45.67	36 S B
MC68020FE16E	L 32BIT MPU16MHZ CQFP	2	36	55.62	36 S
MC68020FE20E	L 32BIT MPU20MHZ CQFP	2	36	63.50	36 S
MC68020FE25E	L 32BIT MPU25MHZ CQFP	2	36	70.89	36 S
MC68020FE33E	L 32BIT MPU33MHZ CQFP	N	36	110.72	36 ★
MC68020RC16E	L 32BIT MPU HCMOS16MHZ PGA	1	14	108.80	14 S
MC68020RC20E	L 32BIT MPU HCMOS20MHZ PGA	1	14	116.74	14 S
MC68020RC25E	L 32BIT HCMOS MPU25MHZ PGA	1	14	124.16	14 S
MC68020RC33E	L 32BIT MPU HCMOS33MHZ PGA	1	14	141.62	14 S
MC68020RP16E	L 32BIT MPU HCMOS16MHZ PGA	1	13	46.26	13 S
MC68020RP20E	L 32BIT MPU HCMOS20MHZ PGA	2	13	50.12	13 S
MC68020RP25E	L 32BIT MPU HCMOS25MHZ PGA	1	13	57.87	13 S
MC6803CP-001	J 8BIT MCU	N	9	10.00	9
MC68030FE16C	L 32BIT ON-CHIP CACHE & MMU	N	36	36.06	36 B
MC68030FE20C	L 32BIT,ON-CHIP CACHE & MMU	N	36	37.96	36 B
MC68030FE25C	L 32BIT,ON-CHIP CACHE & MMU	N	36	45.47	36 B
MC68030FE33C	L 32BIT,ON-CHIP CACHE & MMU	N	36	45.47	36 B
MC68030RC16C	L 32BIT,ON-CHIP CACHE & MMU	N	14	69.50	14 S
MC68030RC20C	L 32BIT ON-CHIP CACHE & MMU	N	14	69.50	14 S
MC68030RC25C	L 32BIT ON-CHIP CACHE & MMU	1	14	79.01	14 S
MC68030RC33C	L 32BIT ON-CHIP CACHE & MMU	1	14	79.01	14 S
MC68030RC40C	L 32BIT,ON-CHIP CACHE & MMU	N	14	87.78	14
MC68030RC50C	L 32BIT,ON-CHIP CACHE & MMU	1	14	97.30	14
MC68030RP16B	L 32BIT,ON-CHIP CACHE & MMU	N	1	76.49	1 S
MC68030RP20B	L 32BIT,ON-CHIP CACHE & MMU	N	1	72.47	1 S
MC68030RP20C	L HI END32-BIT	N	14	68.85	14
MC68030RP25B	L 32BIT,ON-CHIP CACHE & MMU	2	1	88.57	1 S
MC68030RP25C	L HI END32-BIT	N	14	84.14	14
MC68030RP33B	L 32BIT,ON-CHIP CACHE & MMU	1	1	88.57	1 S
MC68030RP33C	L HI END32-BIT	N	14	84.14	14
MC68040FE25	L 32BIT,FPU,CACHE,MMU	N	24	142.21	24 B
MC68040FE25V	L 25MHZ CQFP68040V	N	24	108.25	24 B
MC68040FE33	L 32BIT,FPU,CACHE,MMU	N	24	158.96	24 B
MC68040FE33V	L 33MHZ CQFP68040V	N	24	124.99	24 B
MC68040FE40	L 32BIT,FPU,CACHE,MMU	N	24	262.62	24 B
MC68040FE40V	L 40MHZ CQFP68040V	N	24	158.67	24 B

A = OSPD/Power
 B = Analog/Logic
 J = Transportation
 L = Consumer
 N = Networking
 V = Wireless

S = Proprietary Device
 B = Motorola Blue Chip Program Device
 P = Phoenix Program
 ★ = First Time in Book
 † \$200 Minimum Waived

N = Key New Motorola Device
 R = Key "Focus" Motorola Device

1 = Mature, Stable, High-Volume Device
 2 = Moderate-Volume Device
 3 = Low-Volume Device

COMMERCIAL COMPONENTS

Type No.	Grp/Description	Per Unit Sugg. Factory			PC	Qty	Price	Order	Incrrmnt	Type No.	Grp/Description	Per Unit Sugg. Factory			PC	Qty	Price	Order	Incrrmnt
		Resale	Price	Order								Resale	Price	Order					
MC68040RC25	L 32BIT,FPU,CACHE,MMU	1	10	183.04		10				MC68331CPV16	J MCU-LOWER COST 32-BIT	1	60	10.44	60	B			
MC68040RC25V	L 25MHZ PGA68040V	N	10	160.20		10				MC68331CPV16B1	J 32-BIT MCU,CPU32,SIM,QSM	N	300	9.89	300	B			
MC68040RC33	L 32BI,FPU,CACHE,MMU	1	10	212.53		10				MC68331CPV20	J 32-BIT MCU,CPU32,SIM,QSM	N	60	10.96	60	B			
MC68040RC33V	L 33MHZ PGA68040V	N	10	180.05		10				MC68331CPV20B1	J 32-BIT MCU,CPU32,SIM,QSM,	N	300	10.38	300	B			
MC68040RC40	L 32BIT,FPU,CACHE,MMU	2	10	328.45		10				MC68331CPV25	J MMCU	N	60	11.48	60	B			
MC68040RC40V	L 40MHZ PGA68040V	N	10	225.06		10				MC68331CPV25B1	J MMCU	N	300	10.88	300	B			
MC68150FN33	L 25/33MHZ BUS SIZER	2	18	12.00		18	B			MC68332ACFC16	J 32BIT MCU,2KRAM,TPU,QSM	1	36	13.81	36	B			
MC68150FN33R2	L 25/33MHZ BUS SIZER	2	250	12.00		250	B			MC68332ACFC16B1	J 32BIT MCU,2KRAM,TPU,QSM	N	180	13.26	180	B			
MC68150FN40	L 40MHZ BUS SIZER	2	18	12.72		18	B			MC68332ACFC20	J 32BIT MCU,2KRAM,TPU,QSM	1	36	14.50	36	B			
MC68160BFB	L NHANCD ETHRNT SER TRNSCVR	N	160	22.00		160	S P			MC68332ACFC20B1	J 32BIT MCU,2KRAM,TPU,QSM	N	180	13.92	180	B			
MC68160CFB	L NHANCD ETHRNT SER TRNSCVR	N	160	15.48		160	S P			MC68332ACFC25	J MMCU	N	36	15.19	36	B			
MC68160FB	L NHANCD ETHRNT SER TRNSCVR	1	160	21.29		160				MC68332ACFC25B1	J MMCU	N	180	14.59	180	B			
MC68194FJ	B CARRIER BAND MODEM (CBM)	N	20	133.34		20	S P			MC68332ACPV16	J 32-BIT MCU,CPU32,2KRAM,	N	60	11.61	60	B			
MC68195FN	N LOCAL TALK ADAPTOR	2	1	7.37		1	S			MC68332ACPV16B1	J 32-BIT MCU,CPU32,2K, RAM,T	N	300	11.06	300	B			
MC68302CFC16C	N MULTIPROTOCOL W/DMA, RAM	1	36	22.37		36	S B			MC68332ACPV20	J 32-BIT MCU.CPU32,2K RAM,T	N	60	12.19	60	B			
MC68302FC16C	N MULTIPROTOCOL W/DMA, RAM	1	36	18.65		36	S B			MC68332ACPV20B1	J 32-BIT MCU,CPU32,2KRAM TP	N	300	11.62	300	B			
MC68302FC20C	N MULTIPROTOCOL W/DMA, RAM	1	36	20.65		36	S B			MC68332ACPV25	J MMCU	N	60	12.77	60	B			
MC68302FC25C	N MULTIPROTOCOL W/DMA, RAM	1	36	22.65		36	S B			MC68332ACPV25B1	J MMCU	N	300	12.17	300	B			
MC68302PV16C	N MULTIPROTOCOL W/DMA, RAM	2	60	18.15		60	S B			MC68332GCFC16	J 32BIT MCU,2KRAM,TPU,QSM	2	36	13.81	36	B			
MC68302PV16VC	N MULTIPROTOCOL W/DMA, RAM	N	60	22.68		60	S B			MC68332GCFC16B1	J 32BIT MCU,2KRAM,TPU,QSM	N	180	13.26	180	B			
MC68302PV20C	N MULTIPROTOCOL W/DMA, RAM	2	60	20.15		60	S B			MC68332GCFC20	J 32BIT MCU,2KRAM,TPU,QSM	N	36	14.50	36	B			
MC68302PV25C	N 25MHZ68302144 TQFP	N	60	22.15		60	S B			MC68332GCFC20B1	J 32BIT MCU,2KRAM,TPU,QSM	N	180	13.92	180	B			
MC68302PV33C	N 33MHZ68302 BRICK QTY	N	60	24.15		60	S B			MC68332GCFC25	J MMCU	N	36	15.19	36	B			
MC68302RC16C	N MULTIPROTOCOL W/DMA, RAM	1	1	50.79		1	S B			MC68332GCFC25B1	J MMCU	N	180	14.59	180	B			
MC68302RC20C	N MULTIPROTOCOL W/DMA, RAM	1	1	63.49		1	S B			MC68332GCPV16	J 32-BIT MCU,CPU32,2KRAM,	N	60	11.61	60	B			
MC68302RC25C	N MULTIPROTOCOL W/DMA, RAM	2	1	79.36		1	S B			MC68332GCPV16B1	J 32-BIT MCU,CPU32,2KRAM T	N	300	11.06	300	B			
MC68306FC16	L EC000 W/DUART, DRAM CTRL	1	36	11.55		36	S B			MC68332GCPV20	J 32-BIT MCU, CPU32,2K RAM	N	60	12.19	60	B			
MC68306FC16A	L HI-PERF	N	36	11.55		36	B			MC68332GCPV20B1	J 32-BIT MCU, CPU32,2K RAM	N	300	11.62	300	B			
MC68306PV16	L EC000 W/DUART, DRAM CTRL	N	60	10.81		60	S			MC68332GCPV25	J MMCU	N	60	12.77	60	B			
MC68306PV16A	L HI-PERF	N	60	10.27		60	B			MC68332GCPV25B1	J MMCU	N	300	12.17	300	B			
MC68306PV20A	L HI-PERF	N	60	11.81		60	B			MC68340CFT16E	L INTEGRATED 32-BIT W/DMA	N	24	17.91	24	★	B		
MC68322FT16	L ISD	N	24	33.32		24	★	B		MC68340CFT25E	L INTEGRATED 32-BIT W/DMA	N	24	24.34	24	★	B		
MC68322FT20	L ISD	N	24	35.43		24	★	B		MC68340CPV16E	L CPU32 W/DMA,DURAT, TIMERS	N	60	19.50	60	★	B		
MC68322FT25	L FLEXCORE	N	24	46.62		24	★	B		MC68340CPV25E	L CPU32 W/DMA,DURAT, TIMERS	N	60	26.59	60	★	B		
MC68330PV16A	L CPU32 CORE,16BITS SIM	N	60	15.26		60	S B			MC68340FE16E	L CPU32 W/DMA,DURAT, TIMERS	1	24	26.00	24	B			
MC68330PV16VA	L CPU32 CORE,16BITS SIM	N	60	18.66		60	S B			MC68340FE16VE	L CPU32 W/DMA,DURAT, TIMERS	N	24	33.36	24	B			
MC68330PV25A	L CPU32 CORE,16BITS SIM	N	60	18.66		60	S B			MC68340FE25E	L CPU32 W/DMA,DURAT, TIMERS	1	24	35.10	24	B			
MC68331CFC16	J 32BIT MCU,GPT,SIM,QSM	1	36	12.63		36	B			MC68340FT16E	L CPU32 W/DMA,DURAT, TIMERS	N	24	15.57	24	B			
MC68331CFC16A	J MMCU32-BITHCMOS	N	36	14.67		36	B			MC68340FT25E	L CPU32 W/DMA,DURAT, TIMERS	N	24	21.17	24	B			
MC68331CFC16AB1	J 32-BITHCMOS MCU	N	180	13.89		180	B			MC68340PV16E	L CPU32 W/DMA,DURAT, TIMERS	N	60	15.96	60	B			
MC68331CFC16B1	J 32BIT MCU,GPT,SIM,QSM	2	180	12.08		180	B			MC68340PV16VE	L CPU32 W/DMA,DURAT, TIMERS	N	60	22.34	60	B			
MC68331CFC20	J 32-BIT MCU,CPU32, SIM,	2	36	13.27		36	B			MC68340PV25E	L CPU32 W/DMA,DURAT, TIMERS	N	60	22.34	60	B			
MC68331CFC20B1	J 32BIT MCU,CPU32,SIM,QSM	N	180	13.36		180	B			MC68349FT16A	L LAST ORDER DATE:07/01/98	N	24	47.06	24	S			
MC68331CFC25	J MMCU	N	36	13.90		36	B			MC68349FT16VA	L LAST ORDER DATE:07/01/98	N	24	56.67	24				
MC68331CFC25B1	J MMCU	N	180	13.29		180	B			MC68349FT25A	L LAST ORDER DATE:07/01/98	1	24	56.67	24	S			

A = OSPD/Power
 B = Analog/Logic
 J = Transportation
 L = Consumer
 N = Networking
 V = Wireless

S = Proprietary Device
 B = Motorola Blue Chip Program Device
 P = Phoenix Program
 ★ = First Time in Book
 † \$200 Minimum Waived

N = Key New Motorola Device
 R = Key "Focus" Motorola Device

1 = Mature, Stable, High-Volume Device
 2 = Moderate-Volume Device
 3 = Low-Volume Device

EFFECTIVE DATE: JANUARY 10, 1998

COMMERCIAL COMPONENTS

Type No.	Grp/Description	Per Unit Sugg.			Factory		
		PC	Qty	Resale Price	Order	Price	Incrmnt
MC68360EM25C	N QUICC	N	24	43.55	24	S	B
MC68360EM25VC	N HIGH END	N	24	52.46	24	S	B
MC68360EM33C	N HIGH END	N	24	48.01	24	S	B
MC68360FE25C	N PLEASE USE EMPKG.	1	24	49.50	24	S	
MC68360FE25VC	N PLEASE USE EMPKG.	N	24	59.40	24	S	
MC68360FE33C	N PLEASE USE EMPKG.	N	24	54.45	24	S	
MC68360RC25C	N QUICC	1	1	84.08	1	S	B
MC68360RC33C	N QUICC	N	1	92.48	1	S	B
MC68360ZP25C	N QUICC	N	44	43.55	44	S	B
MC68360ZP25VC	N QUICC	N	44	52.46	44	S	B
MC68360ZP33C	N QUAD. INT. COMM. CTRL	N	44	48.01	44	S	B
MC6845CP	J LAST ORDER DATE:06/10/98	3	9	11.36	9		
MC68605FN10	N X.25 PRTCL CTL10MHZ PLCC	2	1	43.66	1	S	
MC68605FN12	N X.25 PRTCL CTL12MHZ PLCC	N	1	53.88	1	S	
MC68605FN16	N X.25 PRTCL CTL16MHZ PLCC	N	1	73.33	1	S	
MC68605RC10	N X.25 PRTCL CTL10MHZ PGA	1	1	69.74	1	S	
MC68605RC12	N X.25 PRTCL CTL12MHZ PGA	N	1	79.97	1	S	
MC68605RC16	N X.25 PRTCL CTL16MHZ PGA	N	1	94.31	1	S	
MC68606FN12C	N MULTI-LINK LAPD PROTOCOL	N	1	105.16	1		
MC68606FN16C	N MULTI-LINK LAPD PROTOCOL	N	1	174.76	1		
MC68701CS-001	J MPU WITH EPROM	2	9	28.51	9	S	
MC68701U4CS	J 8-BIT MCU	2	9	37.84	9	S	
MC68701U4S-001	J 8-BIT MCU	1	9	38.00	9	S	
MC68824FN12H	N TOKEN BUS CONTROLLER	2	1	67.00	1	S	
MC68824RC12H	N TOKEN BUS CONTROLLER	2	1	94.45	1	S	
MC68824RC16H	N TOKEN BUS CONTROLLER	2	1	126.71	1	S	
MC68836FNB	N FDDI CLOCK GENERATOR	N	1	13.76	1	B	
MC68837FCE	N FDDI ELM CHIP	1	24	21.63	24	S	B
MC68838FCC	N MEDIA ACCESS CONTROLLER	2	24	32.97	24	S	B
MC68839FE	N FDDI SYSTEM INTERFACE	2	24	65.86	24	S	B
MC68840FE25B	N INTEGRATED FDDI	1	24	76.27	24	B	
MC68840FE33B	N INTEGRATED FDDI	N	24	99.16	24	B	
MC68882FN16A	L ENHANCED FPCP16MHZ PLCC	2	1	33.84	1	S	
MC68882FN20A	L ENHANCED FPCP20MHZ PLCC	2	1	37.40	1	S	
MC68882FN25A	L ENHANCED FPCP25MHZ PLCC	1	1	40.61	1	S	
MC68882FN33A	L ENHANCED FPCP33MHZ PLCC	1	1	43.94	1	S	
MC68882FN40A	L ENHANCED FPCP40MHZ PLCC	2	1	67.69	1	S	
MC68882RC16A	L ENHANCED FPCP16MHZ PGA	1	21	53.60	21	S	
MC68882RC20A	L ENHANCED FPCP20MHZ PGA	2	21	53.60	21	S	
MC68882RC25A	L ENHANCED FPCP25MHZ PGA	1	21	61.25	21	S	
MC68882RC33A	L ENHANCED FPCP33MHZ PGA	2	21	61.25	21	S	
MC68882RC40A	L ENHANCED FPCP40MHZ PGA	2	21	77.92	21	S	
MC68882RC50A	L ENHANCED FPCP50MHZ PGA	2	21	100.34	21	S	
MC74ACT00D	B QUAD2-INPUT NAND GATE	1	55	.23	55		†
MC74ACT00DR2	B QUAD2-INPT NAND GATE	2	2500	.23	2500		†

Type No.	Grp/Description	Per Unit Sugg.			Factory		
		PC	Qty	Resale Price	Order	Price	Incrmnt
MC74ACT00DT	B QUAD2-INPUT NAND GATE	N	96	.41	96		†
MC74ACT00N	B QUAD2-INPUT NAND GATE	2	25	.23	500		†
MC74ACT02D	B QUAD2-INPT NOR GATE	N	55	.23	55		†
MC74ACT02DR2	B MONO I/C QUAD2-INPT/GATE	2	2500	.23	2500		†
MC74ACT02DT	B QUAD2-INPT NOR GATE	N	96	.41	96		†
MC74ACT02N	B QUAD2-INPT NOR GATE	2	25	.23	500		†
MC74ACT04D	B HEX INVRTR W/LSTLL INPTS	1	55	.23	55		†
MC74ACT04DR2	B HEX INVRTR W/LSTLL INPTS	1	2500	.23	2500		†
MC74ACT04DT	B HEX INVRTR W/LSTLL INPTS	N	96	.41	96		†
MC74ACT04N	B HEX INVRTR W/LSTLL INPTS	1	25	.23	500		†
MC74ACT05D	B HEX INVERTER	2	55	.23	55		†
MC74ACT05DR2	B HEX INVERTER	2	2500	.23	2500		†
MC74ACT05DT	B HEX INVRT OP DRAN OUTPUT	N	96	.41	96	*	†
MC74ACT05N	B HEX INVERTER	2	25	.23	500		†
MC74ACT08D	B QUAD2-INPUT AND	1	55	.23	55		†
MC74ACT08DR2	B QUAD2-INPUT AND GATE	1	2500	.23	2500		†
MC74ACT08DT	B QUAD2-INPUT AND	N	96	.41	96		†
MC74ACT08N	B QUAD2-INPUT AND	2	25	.23	500		†
MC74ACT10N	B TRIPLE3-INPT NAND	N	25	.23	500		†
MC74ACT109D	B DUAL J-K FLIP FLOP	N	48	.56	48		†
MC74ACT109DR2	B DUAL J-K FLIP FLOP	2	2500	.59	2500		†
MC74ACT109N	B DUAL J-K FLIP FLOP	N	25	.56	500		†
MC74ACT11N	B TRIPLE3-INPT AND GATE	N	25	.23	500		†
MC74ACT112D	B DUL JK NEGE EDGE-TRG FL-FP	N	48	.88	48		†
MC74ACT112N	B DUL JK NEGE EDGE-TRG FL-FP	N	25	.86	500		†
MC74ACT113D	B DUAL J-K NEGE/TRIG F F	N	55	1.22	55	S P	†
MC74ACT113N	B DUAL J-K NEGE/TRIG F F	N	25	1.18	500	S P	†
MC74ACT125D	B QUAD BUFFER/LINE DR	1	55	.76	55		†
MC74ACT125DR2	B QUAD BUFFER/LINE DR	2	2500	.77	2500		†
MC74ACT125DT	B QUAD BUFFER/LINE DR	N	96	.87	96		†
MC74ACT125DR2	B QUAD BUFFER/LINE DR	N	2500	1.12	2500	*	†
MC74ACT125N	B QUAD BUFFER/LINE DR	2	25	.72	500		†
MC74ACT132D	B QUAD2-INPT NDSCHM TRIGG	2	55	.90	55	S	†
MC74ACT132DR2	B QUAD2-INPT NDSCHM TRIGG	2	2500	.92	2500	S	†
MC74ACT138D	B 1-OF-8 DECDR/DEMULPLXR	1	48	.72	48		†
MC74ACT138DR2	B 1-OF-8 DECOD/DEMULPLEXR	2	2500	.76	2500		†
MC74ACT138N	B 1-OF-8 DECDR/DEMULPLXR	2	25	.72	500		†
MC74ACT139D	B DUAL 1OF4 DECOD/DEMULPLX	2	48	.72	48		†
MC74ACT139DR2	B DUAL 1OF4 DECOD/DEMULPLX	2	2500	.76	2500		†
MC74ACT14D	B HEX SCHMITT TRGR INVRTR	1	55	.36	55		†
MC74ACT14DR2	B HEX INVERT SCHMITT TRIGGR	2	2500	.38	2500		†
MC74ACT14N	B HEX SCHMITT TRGR INVRTR	2	25	.36	500		†
MC74ACT151D	B 1-OF-8 DECDR/DEMULPLXR	2	48	.72	48		†
MC74ACT151DR2	B 1-OF-8 DECODER/DEMULPLXR	2	2500	.76	2500		†
MC74ACT151N	B 1-OF-8 DECDR/DEMULPLXR	2	25	.72	500		†

A = OSPD/Power
 B = Analog/Logic
 J = Transportation
 L = Consumer
 N = Networking
 V = Wireless

S = Proprietary Device
 B = Motorola Blue Chip Program Device
 P = Phoenix Program
 * = First Time in Book
 † = \$200 Minimum Waived

N = Key New Motorola Device
 R = Key "Focus" Motorola Device

1 = Mature, Stable, High-Volume Device
 2 = Moderate-Volume Device
 3 = Low-Volume Device

COMMERCIAL COMPONENTS

Type No.	Grp/Description	Per Unit		Sugg. Price	Factory Order	†	Type No.	Grp/Description	Per Unit		Sugg. Price	Factory Order	†	
		PC	Qty						PC	Qty				PC
MC74ACT153D	B DUAL4-INPUT MULTIPLEXER	2	48	.72	48	†	MC74ACT251D	B 8-INPUT MULTIPLEXER	2	48	.72	48	†	
MC74ACT153DR2	B DUAL4-INPUT MULTIPLEXER	2	2500	.76	2500	†	MC74ACT251DR2	B 8-INPUT MULTIPLEXER	2	2500	.76	2500	†	
MC74ACT153N	B DUAL4-INPUT MULTIPLEXER	N	25	.86	500	★	MC74ACT253D	B DU4-INPT MUXW3-STOTPT	2	48	.72	48	†	
MC74ACT157D	B QUAD2-INPUT MUX	1	48	.72	48	†	MC74ACT253DR2	B DU4-INPT MUXW3-STOTPT	2	2500	.76	2500	†	
MC74ACT157DR2	B QUAD2-INPUT MUX	2	2500	.74	2500	†	MC74ACT257D	B QUAD2-INPT MUX3-STOTPT	N	48	.72	48	†	
MC74ACT157N	B QUAD2-INPUT MUX	2	25	.72	500	†	MC74ACT257DR2	B QUAD2-INPT MUX3-STOTPT	N	2500	.76	2500	†	
MC74ACT158D	B QUAD2-INPUT MUX	N	48	.76	48	†	MC74ACT257N	B QUAD2-INPT MUX3-STOTPT	N	25	.72	500	†	
MC74ACT158N	B QUAD2-INPUT MUX	N	25	.72	500	†	MC74ACT258D	B QUAD2-INPT MUX3-STOTPT	2	48	.72	48	†	
MC74ACT160D	B SYNCHRONOUS PRE-SET BCD DC	N	48	1.44	48	★	MC74ACT258DR2	B QUAD2-INPT MUX3-STOTPT	2	2500	.76	2500	†	
MC74ACT160DR2	B PRESETTL BCD DECADE CNTR	N	2500	1.46	2500	★	MC74ACT259D	B 8BIT ADD.LATCH/10R8 DECOD	N	48	2.30	48	S	†
MC74ACT160N	B SYNCHRONOUS PRE-SET BCD DC	N	25	1.40	500	★	MC74ACT273DT	B OCT D F/F CMOS CMPTB-IN	N	75	.90	75	†	
MC74ACT161D	B PRESETTABLE BINARY COUNTR	2	48	1.10	48	†	MC74ACT273DTR2	B OCT D F/F CMOS CMPTB-IN	2	2500	.92	2500	†	
MC74ACT161DR2	B PRESETTABLE BINARY COUNTR	2	2500	1.13	2500	†	MC74ACT273DW	B OCTAL FLIP/FLOP	1	38	.44	38	†	
MC74ACT161N	B PRESETTABLE BINARY COUNTR	2	25	1.08	500	†	MC74ACT273DWR2	B OCTAL FLIP/FLOP	2	1000	.44	1000	†	
MC74ACT162N	B SYNCHRONOUS PRESET BCD	N	25	1.40	500	★S	MC74ACT273N	B OCTAL FLIP/FLOP	2	18	.44	360	†	
MC74ACT163D	B MONO I/C SYNC PRESET BINA	2	48	1.10	48	†	MC74ACT299DW	B 8INPUT SHIFT REG I/O PIN	2	38	1.82	38	†	
MC74ACT163DR2	B MONO I/C SYNC PRESET BINA	2	2500	1.13	2500	†	MC74ACT299DWR2	B 8INPUT SHIFT REG I/O PIN	2	1000	1.84	1000	†	
MC74ACT163N	B MONO I/C SYNC PRESET BINA	2	25	1.08	500	†	MC74ACT299N	B 8INPUT SHIFT REG I/O PIN	2	18	1.80	360	†	
MC74ACT174D	B HEX D F/F W/MR	2	48	.72	48	†	MC74ACT32D	B QUAD2-INPT OR GATE W/TTL	1	55	.23	55	†	
MC74ACT174DR2	B HEX D F/F W/MR	2	2500	.76	2500	†	MC74ACT32DR2	B QUAD2-INPUT OR GATE	1	2500	.23	2500	†	
MC74ACT174N	B HEX D F/F W/MR	2	25	.72	500	†	MC74ACT32DT	B QUAD2-INPT OR GATE W/TTL	N	96	.41	96	†	
MC74ACT175D	B MONOLITHIC QUADD FLP-FLO	N	48	.72	48	†	MC74ACT32N	B QUAD2-INPT OR GATE W/TTL	2	25	.23	500	†	
MC74ACT175DR2	B MONOLITHIC QUADD FLP-FLO	2	2500	.76	2500	†	MC74ACT323DW	B 8-I UNV SHFT/STORAGE REG	2	38	2.27	38	†	
MC74ACT175N	B MONOLITHIC QUADD FLP-FLO	N	25	.72	500	†	MC74ACT323DWR2	B 8-I UNV SHFT/STORAGE REG	2	1000	2.29	1000	†	
MC74ACT20DR2	B DUAL4-INPUT NAND GATE	2	2500	.23	2500	†	MC74ACT323N	B 8-I UNV SHFT/STORAGE REG	2	18	2.25	360	†	
MC74ACT20N	B DUAL4-INPUT NAND GATE	N	25	.23	500	†	MC74ACT373DT	B OCTL TRANSPRNT LTCH W/3ST	N	75	.90	75	†	
MC74ACT240DT	B OCT BUF/LN DRVR TTL CMPTB	N	75	.90	75	†	MC74ACT373DTR2	B OCTL TRANSPRNT LTCH W/3ST	2	2500	.92	2500	†	
MC74ACT240DTR2	B OCTL BUF R LINE DRVR W/3ST	2	2500	.92	2500	†	MC74ACT373DW	B OCTL TRANSPRNT LTCH W/3ST	1	38	.44	38	†	
MC74ACT240DW	B OCT BUF/LN DRVR TTL CMPTB	2	38	.44	38	†	MC74ACT373DWR2	B OCTL TRANSPRNT LTCH W/3ST	2	1000	.44	1000	†	
MC74ACT240DWR2	B OCTL3-ST BUF/LINE DRVR/RE	2	1000	.44	1000	†	MC74ACT373N	B OCTL TRANSPRNT LATCH W/3S	2	18	.44	360	†	
MC74ACT240N	B MOS OCT3-STATE	2	18	.44	360	†	MC74ACT373SD	B OCT D LTCH TTL CMPTBL-IN	N	66	.83	66	†	
MC74ACT241DW	B OCTAL LINE DRIVER	N	38	.44	38	†	MC74ACT374DT	B OCTLD-TYP FLIP/FLOP W/3S	N	75	.90	75	†	
MC74ACT241DWR2	B OCTAL LINE DRIVER	2	1000	.44	1000	†	MC74ACT374DTR2	B OCTLD-TYP FLIP/FLOP W/3S	2	2500	.92	2500	†	
MC74ACT244DT	B OCTL LINE DRVR W/3-STATE	N	75	.90	75	†	MC74ACT374DW	B OCTLD-TYP FLIP/FLOP W/3S	1	38	.44	38	†	
MC74ACT244DTR2	B OCTL LINE DRVR W/3-STATE	2	2500	.92	2500	†	MC74ACT374DWR2	B OCTLD-TYP FLIP/FLOP	2	1000	.44	1000	†	
MC74ACT244DW	B OCTL LINE DRVR W/3-STATE	1	38	.44	38	†	MC74ACT374N	B OCTLD-TYP FLIP/FLOP W/3S	2	18	.44	360	†	
MC74ACT244DWR2	B OCTL3-ST BUF/LINE DRV	1	1000	.44	1000	†	MC74ACT374SD	B OCT D LTCH TTL CMPTBL-IN	N	66	.83	66	†	
MC74ACT244N	B OCTL LINE DRVR W/3-STATE	1	18	.44	360	†	MC74ACT377DW	B OCTAL FLIP/FLOP CLK ENABL	2	38	1.62	38	†	
MC74ACT244SD	B OCT BUF/LN DRVR TTL CMPTB	N	66	.83	66	†	MC74ACT377DWR2	B OCTAL FLIP/FLOP CLK ENABL	2	1000	1.66	1000	†	
MC74ACT245DT	B OCTL BI-DIR TRANSC W/3-ST	N	75	.90	75	†	MC74ACT377N	B OCTAL FLIP/FLOP CLK ENABL	2	18	1.62	360	†	
MC74ACT245DTR2	B OCTL BI-DIR TRANSC W/3-ST	2	2500	.92	2500	†	MC74ACT378D	B PARDREG WITH ENABLE	2	48	1.57	48	S	†
MC74ACT245DW	B OCTL BI-DIR TRANSC W/3-ST	1	38	.44	38	†	MC74ACT378DR2	B PARDREG WITH ENABLE	2	2500	1.58	2500	S	†
MC74ACT245DWR2	B OCTL BI-DIR TRANSC3-ST	1	1000	.44	1000	†	MC74ACT533DW	B OCTAL TRANSPARENT LATCH	2	38	1.21	38	†	
MC74ACT245N	B OCTL BI-DIR CNTRL TRANSC	1	18	.44	360	†	MC74ACT533N	B OCTAL TRANSPARENT LATCH	2	18	1.17	360	†	
MC74ACT245SD	B OCT XCVR:TTL CMPTBL-IN	N	66	.83	66	†	MC74ACT534DW	B D-TYPE FF WITH 3ST OUTPUT	N	38	1.44	38	★	†

A = OSPD/Power
B = Analog/Logic
J = Transportation
L = Consumer
N = Networking
V = Wireless

S = Proprietary Device
B = Motorola Blue Chip Program Device
P = Phoenix Program
★ = First Time in Book
† = \$200 Minimum Waived

N = Key New Motorola Device
R = Key "Focus" Motorola Device

1 = Mature, Stable, High-Volume Device
2 = Moderate-Volume Device
3 = Low-Volume Device

EFFECTIVE DATE: JANUARY 10, 1998

COMMERCIAL COMPONENTS

Type No.	Grp/Description	Per Unit Sugg.		Factory Order	Incrmnt
		Resale Price	Price		
MC74ACT534DWR2	B D-TYPE FF WITH3ST OUTPUT	N	1000	1.46	1000 ★ †
MC74ACT534N	B D-TYPE FF WITH3ST OUTPUT	N	18	1.40	360 ★ †
MC74ACT540DT	B 3-ST;OCTL LINE DRV/NON-IN	N	75	1.01	75 ★ †
MC74ACT540DW	B 3-ST;OCTL LINE DRV/NON-IN	2	38	1.13	38 †
MC74ACT540DWR2	B 3-ST;OCTL LINE DRV/NON-IN	2	1000	1.17	1000 †
MC74ACT540N	B 3-ST;OCTL LINE DRV/NON-IN	2	18	1.12	360 †
MC74ACT541DT	B OCTL LINE DRVR/NON-INVRT	N	75	1.40	75 ★ †
MC74ACT541DTR2	B 3-ST NON-INVRT BUFFER,OCTL	N	2500	1.40	2500 ★ †
MC74ACT541DW	B OCTL LINE DRVR/NON-INVRT	1	38	1.13	38 †
MC74ACT541DWR2	B OCTL LINE DRVR/NON-INVRT	1	1000	1.15	1000 †
MC74ACT541N	B OCTL LINE DRVR/NON-INVRT	1	18	1.12	360 †
MC74ACT564DW	B OCTAL D F/F	N	38	1.44	38 ★ †
MC74ACT564DWR2	B OCTAL D F/F	N	1000	1.46	1000 ★ †
MC74ACT564N	B OCTAL F/F	2	18	1.17	360 †
MC74ACT573DT	B OCTAL LATCH W/3 STATE	N	75	.90	75 †
MC74ACT573DW	B OCTAL LATCH W/3 STATE	2	38	.72	38 †
MC74ACT573DWR2	B OCTAL LATCH W/3 STATE	2	1000	.74	1000 †
MC74ACT573N	B OCTAL LATCH W/3 STATE	1	18	.72	360 †
MC74ACT574DT	B OCTAL F/F W/3 STATE	N	75	.90	75 †
MC74ACT574DW	B OCTAL F/F W/3 STATE	1	38	.72	38 †
MC74ACT574DWR2	B OCTAL F/F W/3 STATE	2	1000	.74	1000 †
MC74ACT574N	B OCTAL F/F W/3 STATE	1	18	.72	360 †
MC74ACT640DW	B OCTL BIDIRECTNL TRANSC	N	38	3.27	38 ★ S †
MC74ACT640N	B OCTL BIDIRECTNL TRANSC	2	18	2.70	360 S †
MC74ACT643DWR2	B OCT BIDIRECTION TRANS	2	1000	2.75	1000 S †
MC74ACT643N	B OCT BIDIRECTION TRANS	2	18	2.70	360 S †
MC74ACT646DW	B OCTAL TRANSCEIVER/REGISTR	2	30	2.88	30 †
MC74ACT646DWR2	B OCTAL TRANSCEIVER/REGISTR	2	1000	2.88	1000 †
MC74ACT646N	B OCTAL TRANSCEIVER/REGISTR	2	15	2.88	15 †
MC74ACT652DW	B OCT BUS TRNSCVER/REGSTER	2	30	3.37	30 †
MC74ACT652DWR2	B OCT BUS TRNSCVER/REGSTER	2	1000	3.38	1000 †
MC74ACT652N	B OCT BUS TRNSCVER/REGSTER	2	15	3.33	15 †
MC74ACT74D	B DUAL D-TYP POS EDG TRGR	1	55	.40	55 †
MC74ACT74DR2	B DUAL D-TYP POS EDG TRGGR	1	2500	.41	2500 †
MC74ACT74DT	B DUAL D-TYP POS EDG TRGR	N	96	.83	96 †
MC74ACT74N	B DUAL D-TYP POS EDG TRGR	1	25	.40	500 †
MC74ACT86D	B QUAD2-IN EXCLOR GATE	2	55	.40	55 †
MC74ACT86DR2	B QUAD2-INPT EXCLOR GATE	2	2500	.41	2500 †
MC74ACT86DT	B QUAD2-IN EXCLOR GATE	N	96	.90	96 †
MC74ACT86DTR2	B QUAD2-IN EXCLOR GATE	2	2500	.92	2500 †
MC74ACT86N	B QUAD2-IN EXCLOR GATE	2	25	.40	500 †
MC74AC00D	B QUAD2-INPUT NAND GATE	2	55	.23	55 †
MC74AC00DR2	B QUAD2-IN NAND	2	2500	.23	2500 †
MC74AC00DT	B QUAD2-INPUT NAND GATE	N	96	.41	96 †
MC74AC00N	B MOS GATE, NAND, QUAD,2-I	2	25	.23	500 †

Type No.	Grp/Description	Per Unit Sugg.		Factory Order	Incrmnt
		Resale Price	Price		
MC74AC02D	B QUAD2-INPUT NOR GATE	2	55	.23	55 †
MC74AC02DR2	B QUAD2-IN NOR GATE	2	2500	.23	2500 †
MC74AC02DT	B QUAD2-INPUT NOR GATE	N	96	.41	96 †
MC74AC02N	B QUAD2-INPUT NOR GATE	2	25	.23	500 †
MC74AC04D	B HEX INVERTER	1	55	.23	55 †
MC74AC04DR2	B HEX INVERTER	2	2500	.23	2500 †
MC74AC04DT	B HEX INVERTER	N	96	.41	96 †
MC74AC04N	B HEX INVERTER	2	25	.23	500 †
MC74AC05D	B HEX INVERTER OPEN-DRAIN	2	55	.23	55 †
MC74AC05DR2	B HEX INVERTER OPEN-DRAIN	2	2500	.23	2500 †
MC74AC05N	B HEX INVERTER OPEN-DRAIN	2	25	.23	500 †
MC74AC08D	B QUAD2-IN AND	2	55	.23	55 †
MC74AC08DR2	B QUAD2-INPUT AND GATE	2	2500	.23	2500 †
MC74AC08DT	B QUAD2-INPUT AND GATE	N	96	.41	96 †
MC74AC08N	B QUAD2-IN AND	2	25	.23	500 †
MC74AC10DR2	B TRIPLE3-INPT NAND GATE	2	2500	.23	2500 †
MC74AC10N	B OCTLD-TYP FLP/FLP W/3ST	N	25	.23	500 †
MC74AC109DR2	B DUAL J/K FLIP-FLOP	2	2500	.58	2500 †
MC74AC11D	B TRIPLE3-INPT AND	N	55	.23	55 †
MC74AC11DR2	B TRIPLE3-INPUT AND GATE	2	2500	.23	2500 †
MC74AC11N	B TRIPLE3-INPT AND	N	25	.23	500 †
MC74AC112D	B DUAL NEG EDGE-TRIGG F PFO	N	48	.88	48 †
MC74AC112N	B DUAL NEG EDGE-TRIGG FLIP	N	25	.86	500 †
MC74AC113D	B DUAL J-K NEG E TRIG F F	N	55	1.22	55 S P †
MC74AC113N	B DUAL J-K NEG E TRIG F F	N	25	1.18	500 S P †
MC74AC125D	B OCT BUF/LNDR3-ST OUTPUT	2	55	.76	55 †
MC74AC125DR2	B OCT BUF/LNDR3-ST OUTPUT	2	2500	.77	2500 †
MC74AC125DT	B OCT BUF/LNDR3-ST OUTPUT	N	96	.87	96 †
MC74AC125N	B OCT BUF/LNDR3-ST OUTPUT	2	25	.72	500 †
MC74AC138D	B 1-OF-8 DECDR/DEMUTPLXR	2	48	.72	48 †
MC74AC138DR2	B 1-OF-8 DECDR/DEMUTPLXR	1	2500	.76	2500 †
MC74AC138N	B 1-OF-8 DECDR/DEMUTPLXR	2	25	.72	500 †
MC74AC139D	B DUAL1-OF-4 DECDR/DEMUXIP	2	48	.72	48 †
MC74AC139DR2	B DUAL1 OF4 DECODER/DEMUX	2	2500	.76	2500 †
MC74AC139N	B DUAL1-OF-4 DECDR/DEMUXIP	2	25	.72	500 †
MC74AC14D	B HEX INVERTR SCHMITT TRIGR	2	55	.36	55 †
MC74AC14DR2	B HEX INVRTR SCHMITT TRGGR	2	2500	.38	2500 †
MC74AC14N	B HEX INVERTR SCHMITT TRIGR	1	25	.36	500 †
MC74AC151D	B 1-OF-8 DECDR/DEMUTPLXR	2	48	.72	48 †
MC74AC151DR2	B 1-OF-8 DECDR/DEMUTPLXR	2	2500	.76	2500 †
MC74AC151N	B 1-OF-8 DECDR/DEMUTPLXR	2	25	.72	500 †
MC74AC153DR2	B DUAL4-INPT MULTIPLXR	2	2500	.76	2500 †
MC74AC157D	B QUAD2-INPT MULTIPLXR	2	48	.72	48 †
MC74AC157DR2	B QUAD2-INPT DATA SELCTR	2	2500	.76	2500 †
MC74AC157N	B QUAD2-INPT MULTIPLXR	2	25	.72	500 †

A = OSPD/Power
 B = Analog/Logic
 J = Transportation
 L = Consumer
 N = Networking
 V = Wireless

S = Proprietary Device
 B = Motorola Blue Chip Program Device
 P = Phoenix Program
 ★ = First Time in Book
 † \$200 Minimum Waived

N = Key New Motorola Device
 R = Key "Focus" Motorola Device

1 = Mature, Stable, High-Volume Device
 2 = Moderate-Volume Device
 3 = Low-Volume Device

EFFECTIVE DATE: JANUARY 10, 1998

COMMERCIAL COMPONENTS

Type No.	Grp/Description	Per Unit Sugg. Factory			PC	Qty	Price	Order	Incrrmt	Type No.	Grp/Description	Per Unit Sugg. Factory			PC	Qty	Price	Order	Incrrmt	
		Resale	Price	Order								Resale	Price	Order						
MC74AC160D	B BCDDECADECOUNTER	2	48	1.21	48	S	†		MC74AC273N	B OCTALD-FLIP FLOP	2	18	.44	360	†					
MC74AC160DR2	B BCDDECADECOUNTER	2	2500	1.22	2500	S	†		MC74AC32D	B QUAD2-INPUT OR GATE	1	55	.23	55	†					
MC74AC160N	B BCDDECADECOUNTER	2	25	1.17	500	S	†		MC74AC32DR2	B QUAD2-INPUT OR GATE	2	2500	.23	2500	†					
MC74AC161D	B SNYCHPRSETTABLE BIN CNTR	2	48	1.08	48		†		MC74AC32DT	B QUAD2-INPUT OR GATE	N	96	.41	96	†					
MC74AC161DR2	B SNYCHPRSETTABLE BIN CNTR	2	2500	1.12	2500		†		MC74AC32N	B QUAD2-INPUT OR GATE	2	25	.23	500	†					
MC74AC161N	B SNYCHPRSETTABLE BIN CNTR	2	25	1.08	500		†		MC74AC373DT	B MOS OCT TRANSPARENT LTCH	N	75	.90	75	†					
MC74AC163D	B SYNCHRONOUS PRESETBL BINA	2	48	1.08	48		†		MC74AC373DTR2	B OCTLD-TYP FLIP/FLOP W/3S	2	2500	.92	2500	†					
MC74AC163DR2	B SYNCHRONOUS PRESETTBL	2	2500	1.12	2500		†		MC74AC373DW	B MOS OCT TRANSPARENT LTCH	2	38	.44	38	†					
MC74AC163N	B SYNCHRONOUS PRESETBL BINA	2	25	1.08	500		†		MC74AC373DWR2	B OCTL TRANSPARENT LATCH	2	1000	.44	1000	†					
MC74AC174D	B HEXD-FLP/FLP W/MSTR REST	2	48	.72	48		†		MC74AC373N	B MOS OCT TRANSPARENT LTCH	2	18	.44	360	†					
MC74AC174DR2	B HEXD-TYP FLIP/FLOP W/MST	2	2500	.76	2500		†		MC74AC374DT	B OCTLD-TYP FLIP-FLOP W/3S	N	75	.90	75	†					
MC74AC174N	B HEXD-FLP/FLP W/MSTR REST	2	25	.72	500		†		MC74AC374DTR2	B OCTLD-TYP FLIP-FLOP W/3S	2	2500	.92	2500	†					
MC74AC175D	B QUARD FLIP-FLOP	N	48	.72	48		†		MC74AC374DW	B OCTLD-TYP FLIP-FLOP W/3S	2	38	.44	38	†					
MC74AC175DR2	B QUARD FLIP-FLOP	2	2500	.76	2500		†		MC74AC374DWR2	B MOS OCTAL4-TYPE FLIP-FLO	2	1000	.44	1000	†					
MC74AC175N	B QUARD FLIP-FLOP	N	25	.72	500		†		MC74AC374N	B OCTLD-TYP FLIP/FLP W/3ST	2	18	.44	360	†					
MC74AC20D	B DUAL4 INPUT NAND GATE	2	55	.40	55		†		MC74AC4040N	B 12-STAGE BINARY RIPL CNTR	2	25	1.73	500	S	†				
MC74AC20DR2	B DUAL4 INPUT NAND GATE	2	2500	.41	2500		†		MC74AC533DW	B OCTAL TRANSPARENT LATCH	2	38	1.21	38	†					
MC74AC20N	B DUAL4 INPUT NAND GATE	2	25	.36	500		†		MC74AC533DWR2	B OCTAL TRANSPARENT LATCH	2	1000	1.22	1000	†					
MC74AC240DT	B OCTL BUFR LINE DRVR W/3ST	N	75	.90	75		†		MC74AC534DW	B OCTALD FLIP-FLOP	2	38	1.21	38	†					
MC74AC240DTR2	B OCTL BUFR LINE DRVR W/3ST	2	2500	.92	2500		†		MC74AC534DWR2	B OCTALD FLIP-FLOP	2	1000	1.21	1000	†					
MC74AC240DW	B OCTL BUFR LINE DRVR W/3ST	N	38	.44	38		†		MC74AC534N	B OCTALD FLIP-FLOP	2	18	1.17	360	†					
MC74AC240DWR2	B OCTL3-ST BUFR/LINE DRVR/RE	2	1000	.44	1000		†		MC74AC540DWR2	B OCTL INVRT LN DRVR W/3-ST	2	1000	1.15	1000	†					
MC74AC240N	B OCTL BUFR LINE DRVR W/3ST	2	18	.44	360		†		MC74AC540N	B OCTL BUFFER LINE DRVR	2	18	1.12	360	†					
MC74AC241DW	B OCTAL LINE DRIVER	2	38	.44	38		†		MC74AC541DTR2	B 3-ST NON-INVRT BUFR, OCTL	2	2500	1.49	2500	†					
MC74AC241DWR2	B OCTAL LINE DRIVER	2	1000	.44	1000		†		MC74AC541DW	B 3-ST NON-INVRT BUFR, OCTL	2	38	1.13	38	†					
MC74AC241N	B OCTAL LINE DRIVER	2	18	.44	360		†		MC74AC541DWR2	B 3-ST NON-INVRT BUFR, OCTL	2	1000	1.15	1000	†					
MC74AC244DT	B OCTL LINE DRVR W/3-STATE	N	75	.90	75		†		MC74AC541N	B OCTL LINE DRVR W/INVRT3ST	2	18	1.12	360	†					
MC74AC244DTR2	B OCTL LINE DRVR W/3-STATE	2	2500	.92	2500		†		MC74AC573DT	B OCTAL LATCH W/TRI STATE	N	75	.90	75	†					
MC74AC244DW	B OCTL LINE DRVR W/3-STATE	2	38	.44	38		†		MC74AC573DW	B OCTAL LATCH W/TRI STATE	2	38	.72	38	†					
MC74AC244DWR2	B OCTL LINE DRVR W/3-ST	2	1000	.44	1000		†		MC74AC573DWR2	B OCTAL LATCH W/TRI STATE	2	1000	.74	1000	†					
MC74AC244N	B OCTL LINE DRVR W/3-STATE	1	18	.44	360		†		MC74AC573N	B OCTAL LATCH W/TRI STATE	1	18	.72	360	†					
MC74AC244SD	B OCTL LINE DRVR W/3-STATE	N	66	.83	66		†		MC74AC574DT	B OCTALD F/F W/3 STATE	N	75	.90	75	†					
MC74AC245DT	B OCTL BI-DIR TRANSC W/3-ST	N	75	.90	75		†		MC74AC574DW	B OCTALD F/F W/3 STATE	2	38	.72	38	†					
MC74AC245DTR2	B OCTL BI-DIR TRANSC W/3-ST	2	2500	.92	2500		†		MC74AC574DWR2	B OCTALD F/F W/3 STATE	2	1000	.74	1000	†					
MC74AC245DW	B OCTL BI-DIR TRANSC W/3-ST	1	38	.44	38		†		MC74AC574N	B OCTALD F/F W/3 STATE	2	18	.72	360	†					
MC74AC245DWR2	B OCTL BIDIR TRANSC V W/3-ST	2	1000	.44	1000		†		MC74AC646N	B OCTL TRANS/REG W/3-ST	N	15	2.88	15	†					
MC74AC245N	B OCTL BI-DIRECTIONL TRANSC	2	18	.44	360		†		MC74AC652DW	B OCTAL BUS TRNSCVER/REGSTR	2	30	3.37	30	†					
MC74AC251D	B 8-INPUT MULTIPLEXER	2	48	.72	48		†		MC74AC652DWR2	B OCTAL BUS TRNSCVER/REGSTR	2	1000	3.38	1000	†					
MC74AC251DR2	B 8-INPUT MULTIPLEXER	2	2500	.76	2500		†		MC74AC652N	B OCTAL BUS TRNSCVER/REGSTR	2	15	3.35	15	†					
MC74AC251N	B 8-INPUT MULTIPLEXER	2	25	.72	500		†		MC74AC74D	B DUALD-TYP POS EDG TRGGR	1	55	.40	55	†					
MC74AC257DR2	B QUAD2-INPT MUX3 ST OTPT	2	2500	.76	2500		†		MC74AC74DR2	B DUALD-TYP POSTV EDG TRGG	2	2500	.41	2500	†					
MC74AC273DT	B OCT D F/F CMOS CMTB-IN	N	75	.90	75		†		MC74AC74DT	B DUALD-TYP POS EDG TRGGR	N	96	.83	96	†					
MC74AC273DTR2	B OCT D F/F CMOS CMTB-IN	2	2500	.92	2500		†		MC74AC74N	B DUALD-TYP POS EDG TRGGR	2	25	.40	500	†					
MC74AC273DW	B OCTALD-TYPE FLIP/FLOP	2	38	.44	38		†		MC74AC86D	B QUAD2-IN EXCL OR GATE	2	55	.40	55	†					
MC74AC273DWR2	B OCTLD FLIP/FLOP	2	1000	.44	1000		†		MC74AC86DR2	B QUAD2 INPUT EXCL OR GATE	2	2500	.41	2500	†					

A = OSPD/Power
 B = Analog/Logic
 J = Transportation
 L = Consumer
 N = Networking
 V = Wireless

S = Proprietary Device
 B = Motorola Blue Chip Program Device
 P = Phoenix Program
 ★ = First Time in Book
 † \$200 Minimum Waived

N = Key New Motorola Device
 R = Key "Focus" Motorola Device

1 = Mature, Stable, High-Volume Device
 2 = Moderate-Volume Device
 3 = Low-Volume Device

COMMERCIAL COMPONENTS

Type No.	Grp/Description	Per Unit Sugg. Factory			†	
		PC	Qty	Price		
MC74AC86N	B QUAD2-IN EXCLOR GATE	2	25	.40	500	†
MC74F00D	B FAST QD2I/P NAND GATE	1	55	.19	55	†
MC74F00DR2	B FAST QD2I/P NAND GATE	2	2500	.19	2500	†
MC74F00N	B FAST QD2I/P NAND GATE	1	25	.19	500	†
MC74F02D	B FAST QD2I/P NOR GATE	2	55	.19	55	†
MC74F02DR2	B FAST QD2I/P NOR GATE	2	2500	.19	2500	†
MC74F02N	B FAST QD2I/P NOR GATE	2	25	.19	500	†
MC74F04D	B FAST HEX INVERTER	1	55	.19	55	†
MC74F04DR2	B FAST HEX INVERTER	2	2500	.19	2500	†
MC74F04N	B FAST HEX INVERTER	1	25	.19	500	†
MC74F08D	B FAST QD2I/P AND GATE	1	55	.19	55	†
MC74F08DR2	B FAST QD2I/P AND GATE	2	2500	.19	2500	†
MC74F08N	B FAST QD2I/P AND GATE	1	25	.19	500	†
MC74F10D	B FAST3I/P NAND GATE	2	55	.19	55	†
MC74F10DR2	B FAST3I/P NAND GATE	2	2500	.19	2500	†
MC74F10N	B FAST3I/P NAND GATE	2	25	.19	500	†
MC74F109D	B FAST DL JK POS EDG-TRG FF	2	48	.45	48	†
MC74F109DR2	B FAST DL JK POS EDG-TRG FF	2	2500	.49	2500	†
MC74F109N	B FAST DL JK POS EDG-TRG FF	2	25	.45	500	†
MC74F11D	B FAST TRPL3I/P AND GATE	2	55	.19	55	†
MC74F11DR2	B FAST TRPL3I/P AND GATE	2	2500	.19	2500	†
MC74F11N	B FAST TRPL3I/P AND GATE	2	25	.19	500	†
MC74F112D	B FAST DL J-K NEG EDGE FF	2	48	.52	48	†
MC74F112DR2	B FAST DL J-K NEG EDGE FF	2	2500	.54	2500	†
MC74F112N	B FAST DL J-K NEG EDGE FF	2	25	.52	500	†
MC74F1245N	B OCTAL TRANSCEIVER3-STATE	2	18	2.34	360	†
MC74F125D	B FAST QD BUFFER	1	55	.54	55	†
MC74F125DR2	B FAST QUAD BUFFER3-S	2	2500	.58	2500	†
MC74F125N	B FAST QD BUFFER	1	25	.54	500	†
MC74F126D	B FAST QD BUFFER	2	55	.54	55	†
MC74F126DR2	B FAST QUAD BUFFER	2	2500	.58	2500	†
MC74F126N	B FAST QD BUFFER	2	25	.54	500	†
MC74F132DR2	B FAST QD2-INP ND SCHMT TR	2	2500	.61	2500	†
MC74F132N	B FAST QD2IN ND SHMT TRGR	2	25	.43	500	†
MC74F138D	B FAST1-OF-8DEC/DEMUX	1	48	.45	48	†
MC74F138DR2	B FAST1-OF-8DEC/DEMUX	2	2500	.49	2500	†
MC74F138N	B FAST1-OF-8DEC/DEMUX	1	25	.45	500	†
MC74F139D	B FAST DL1-OF-4 DECODER	2	48	.54	48	†
MC74F139DR2	B FAST DL1-OF-4 DECODER	2	2500	.58	2500	†
MC74F139N	B FAST DL1-OF-4 DECODER	1	25	.54	500	†
MC74F14D	B FAST HEX INVRTR SCHM TRGR	1	55	.41	55	†
MC74F14DR2	B HEX INVRTR SCH TRGR	2	2500	.43	2500	†
MC74F14N	B FAST HEX INV SHMT TRGR	2	25	.41	500	†
MC74F148D	B FAST8LN TO3LN DECODER	2	48	.81	48	†
MC74F148DR2	B FAST8LN TO3LN DECODER	2	2500	.85	2500	†

Type No.	Grp/Description	Per Unit Sugg. Factory			†	
		PC	Qty	Price		
MC74F148N	B FAST8LN TO3LN DECODER	2	25	.81	500	†
MC74F151D	B FAST8 I/P MUX	2	48	.47	48	†
MC74F151DR2	B FAST8 I/P MUX	2	2500	.49	2500	†
MC74F151N	B FAST8 I/P MUX	2	25	.45	500	†
MC74F153D	B FAST DL4I/P MUX	2	48	.45	48	†
MC74F153DR2	B FAST DL4I/P MUX	2	2500	.49	2500	†
MC74F153N	B FAST DL4I/P MUX	2	25	.45	500	†
MC74F157AD	B FAST QD2I/P MUX	1	48	.45	48	†
MC74F157ADR2	B FAST QD2I/P MUX	2	2500	.49	2500	†
MC74F157AN	B FAST QD2I/P MUX	1	25	.45	500	†
MC74F158AD	B FAST QD2I/P MUX	2	48	.45	48	†
MC74F158ADR2	B FAST QUAD2-1 MUX	2	2500	.49	2500	†
MC74F158AN	B FAST QD2I/P MUX	2	25	.45	500	†
MC74F161AD	B FAST SYNC PRESET BIN CNTR	2	48	.67	48	†
MC74F161ADR2	B FAST SYNC PRESET BIN CNTR	2	2500	.70	2500	†
MC74F161AN	B FAST SYNC PRESET BIN CNTR	1	25	.63	500	†
MC74F163AD	B FAST SYNC PRESET BIN CNTR	2	48	.67	48	†
MC74F163ADR2	B FAST SYNC PRESET BIN CNTR	2	2500	.70	2500	†
MC74F163AN	B FAST SYNC PRESET BIN CNTR	1	25	.63	500	†
MC74F164D	B 8BIT SER IN-SER OUT SHFT	2	55	.68	55	†
MC74F164DR2	B 8BIT SER IN-SER OUT SHFT	2	2500	.70	2500	†
MC74F164N	B 8BIT SER IN-SER OUT SHFT	1	25	.63	500	†
MC74F169D	B FAST UP/DOWN BINARY CNTR	2	48	1.44	48	†
MC74F169DR2	B FAST UP/DOWN BINARY CNTR	2	2500	1.46	2500	†
MC74F169N	B FAST UP/DOWN BINARY CNTR	2	25	1.44	500	†
MC74F174D	B FAST HEX DFF W/MSTR RS	2	48	.65	48	†
MC74F174DR2	B FAST HEX DFF W/MSTR RS	2	2500	.67	2500	†
MC74F174N	B FAST HEX DFF W/MSTR RS	2	25	.65	500	†
MC74F175D	B FAST QD D FLIP FLOP	2	48	.50	48	†
MC74F175DR2	B FAST QD D FLIP FLOP	2	2500	.54	2500	†
MC74F175N	B FAST QD D FLIP FLOP	2	25	.50	500	†
MC74F1803D	B CLOCK DRIVER	2	55	5.13	55 S P	†
MC74F1803N	B QUAD DTYPE FLIP FLOP	2	25	5.10	500 S P	†
MC74F182DR2	B FAST CARRY LKAHEAD GEN	2	2500	1.49	2500	†
MC74F194D	B FAST16LD SOIC	2	48	1.53	48	†
MC74F194DR2	B FAST UNIVRSL SHIFT REGSTR	2	2500	1.55	2500	†
MC74F194N	B UNIVERSAL SHIFT REG	2	25	1.53	500	†
MC74F20D	B FAST DL4I/P NAND GATE	2	55	.19	55	†
MC74F20DR2	B FAST DL4I/P NAND GATE	2	2500	.19	2500	†
MC74F20N	B FAST DL4I/P NAND GATE	2	25	.19	500	†
MC74F2245DW	B FAST OCTAL BDIR XCEIVER	N	38	.58	38	†
MC74F2245DWR2	B FAST OCTAL BDIR XCEIVER	N	1000	.60	1000	†
MC74F2245SD	B FAST OCTAL BDIR XCEIVER	N	66	.75	66	†
MC74F2245SDR2	B FAST OCTAL BDIR XCEIVER	N	1000	.77	1000	†
MC74F240DW	B FAST OCTAL BUFF/LNE DRVR	2	38	.32	38	†

A = OSPD/Power
 B = Analog/Logic
 J = Transportation
 L = Consumer
 N = Networking
 V = Wireless

S = Proprietary Device
 B = Motorola Blue Chip Program Device
 P = Phoenix Program
 * = First Time in Book
 † \$200 Minimum Waived

N = Key New Motorola Device
 R = Key "Focus" Motorola Device

1 = Mature, Stable, High-Volume Device
 2 = Moderate-Volume Device
 3 = Low-Volume Device

EFFECTIVE DATE: JANUARY 10, 1998

COMMERCIAL COMPONENTS

Type No.	Grp/Description	Per Unit Sugg. Factory			†	Type No.	Grp/Description	Per Unit Sugg. Factory			†		
		PC	Qty	Price				Order	PC	Qty		Price	Order
MC74F240DWR2	B FAST OCTAL BUFF/LNE DRVR	2	1000	.32	1000	†	MC74F365D	B FASTHEXBUFFER	2	48	1.08	48	†
MC74F240N	B FAST OCTAL BUFF/LNE DRVR	2	18	.32	360	†	MC74F367D	B FASTHEXBUFFER	2	48	1.08	48	†
MC74F240SD	B OCTALBUS/LINE DRIVERINV	N	66	.75	66	†	MC74F367DR2	B FASTHEXBUFFER	2	2500	1.10	2500	†
MC74F240SDR2	B OCTALBUS/LINE DRIVERINV	2	1000	.77	1000	†	MC74F367N	B FASTHEXBUFFER	2	25	1.08	500	†
MC74F241DW	B FAST OCTAL BUFF/LNE DRVR	2	38	.65	38	†	MC74F373DW	B FASTOCTALXPRNT LATCH	2	38	.32	38	†
MC74F241DWR2	B FAST OCTAL BUFF/LNE DRVR	2	1000	.67	1000	†	MC74F373DWR2	B FASTOCTALXPRINT LATCH	1	1000	.32	1000	†
MC74F241N	B FAST OCTAL BUFF/LNE DRVR	2	18	.61	360	†	MC74F373N	B FASTOCTALXPRNT LATCH	1	18	.32	360	†
MC74F244DW	B FAST OCTAL BUFF/LNE DRVR	1	38	.32	38	†	MC74F373SD	B OCTALTRANSPARENT LATCH/3	N	66	.75	66	†
MC74F244DWR2	B FAST OCTAL BUFF/LNE DRVR	1	1000	.32	1000	†	MC74F373SDR2	B OCTALTRANSPARENT LATCH/3	2	1000	.77	1000	†
MC74F244N	B FAST OCTAL BUFF/LNE DRVR	1	18	.32	360	†	MC74F374DW	B FASTOCTALDTYPE FF	1	38	.32	38	†
MC74F244SD	B OCTALBUS DRIVER/NON/INVR	N	66	.75	66	†	MC74F374DWR2	B FASTOCTALDTYPE FF	2	1000	.32	1000	†
MC74F244SDR2	B OCTALBUS DRIVER/NON/INVR	2	1000	.77	1000	†	MC74F374N	B FASTOCTALDTYPE FF	1	18	.32	360	†
MC74F245DW	B FASTOCTALBDIRXCEIVER	1	38	.65	38	†	MC74F374SD	B OCTALDTYPE FLIP-FLOP	N	66	.75	66	†
MC74F245DWR2	B FASTOCTALBDIRXCEIVER	1	1000	.74	1000	†	MC74F374SDR2	B OCTALDTYPE FLIP-FLOP	2	1000	.77	1000	†
MC74F245N	B FASTOCTALBDIRXCEIVER	1	18	.32	360	†	MC74F377DW	B OCTLDFFW/CLK ENABLE	2	38	1.80	38	†
MC74F245SD	B OCTALBUS TRANSCEIVER	N	66	.75	66	†	MC74F377N	B FASTOCTALDFFW/CLK ENA	2	18	1.80	360	†
MC74F245SDR2	B OCTALBUS TRANSCEIVER	2	1000	.77	1000	†	MC74F378D	B FASTPARADREGW/ENABLE	2	48	1.01	48	†
MC74F251D	B FAST8I/PMUX	2	48	.59	48	†	MC74F378DR2	B FASTPARADREGW/ENABLE	2	2500	1.03	2500	†
MC74F251DR2	B FAST8I/PMUX	3	2500	1.40	2500	†	MC74F378N	B FASTPARADREGW/ENABLE	2	25	1.01	500	†
MC74F251N	B FAST8I/PMUX	2	25	.59	500	†	MC74F379DR2	B FASTODPARAREGW/ENABLE	2	2500	1.06	2500	†
MC74F253D	B FASTDL4I/PMUX3ST	2	48	.49	48	†	MC74F379N	B FASTODPARAREGW/ENABLE	2	25	1.01	500	†
MC74F253DR2	B FASTDL4I/PMUX3ST	2	2500	.52	2500	†	MC74F38D	B QUAD2INPUT NAND BUFFER	1	55	.40	55	†
MC74F253N	B FASTDL4I/PMUX3ST	2	25	.49	500	†	MC74F38DR2	B QUAD2INPUT NAND BUFFER	2	2500	.43	2500	†
MC74F257AD	B FASTQD3I/PMUX	2	48	.49	48	†	MC74F38N	B QUAD2INPUT NAND BUFFER	2	25	.40	500	†
MC74F257ADR2	B FASTQD3I/PMUX	2	2500	.52	2500	†	MC74F399D	B FASTQD2-PORT REGISTER	2	48	1.26	48	†
MC74F257AN	B FASTQD3I/PMUX	1	25	.49	500	†	MC74F399DR2	B FASTQD2-PORT REGISTER	2	2500	1.30	2500	†
MC74F258AD	B FASTQD2I/PMUX	2	48	.49	48	†	MC74F399N	B FASTQD2-PORT REGISTER	2	25	1.26	500	†
MC74F258ADR2	B FASTQUAD2-1MUXINV3-S	2	2500	.52	2500	†	MC74F521DW	B FASTOCTALCOMPARATOR	2	38	.90	38	†
MC74F258AN	B FASTQD2I/PMUX	2	25	.49	500	†	MC74F521DWR2	B FASTOCTALCOMPARATOR	2	1000	.92	1000	†
MC74F259D	B FAST16LDSOIC	2	48	2.43	48	†	MC74F521N	B FASTOCTALCOMPARATOR	1	18	.53	360	†
MC74F259DR2	B FASTDL8-BITADRSBL LAT	N	2500	2.45	2500	†	MC74F533DW	B FASTOCTALXPRNT LATCH	2	38	1.08	38	†
MC74F259N	B TTL8BITADRESSABLE LATCH	2	25	2.43	500	†	MC74F533N	B FASTOCTALXPRNT LATCH	2	18	1.06	360	†
MC74F269DW	B 8-BIT COUNTER	1	30	3.60	30	†	MC74F534N	B FASTOCTALD-TYPE FF	2	18	1.17	360	†
MC74F269DWR2	B 8-BIT COUNTER	N	1000	3.60	1000	†	MC74F543DW	B OCTALREGTRANSC	2	30	1.62	30	†
MC74F269N	B 8-BIT COUNTER	1	15	3.60	15	†	MC74F543DWR2	B OCTALREGTRANSC	2	1000	1.62	1000	†
MC74F280D	B FAST9-BITPARITY GEN/CHK	2	55	.45	55	†	MC74F543N	B OCTALREGTRANSCEIVER	2	15	1.62	15	†
MC74F280DR2	B FAST9-BITPARITY GEN/CHK	2	2500	.49	2500	†	MC74F544DW	B OCTREGTRANINV3-ST	2	30	1.62	30	†
MC74F280N	B FAST9-BITPARITY GEN/CHK	2	25	.45	500	†	MC74F544N	B OCTALREGISTER TRANSCEIVR	2	15	1.62	15	†
MC74F283D	B FAST4-BITFULL ADDER	2	48	.90	48	†	MC74F569DW	B BINARYUP/DOWN COUNTR3-S	2	38	1.80	38	†
MC74F283DR2	B FAST4-BITFULL ADDER	2	2500	.94	2500	†	MC74F569DWR2	B BINARYUP/DOWN COUNTR3-S	2	1000	1.80	1000	†
MC74F283N	B FAST4-BITFULL ADDER	1	25	.90	500	†	MC74F569N	B FASTUP/DN BIN CNTR3-ST	2	18	1.80	360	†
MC74F299DW	B 8-BIT UNIV SHFT REG	2	38	4.05	38	†	MC74F574DW	B OCTDFLIP/FLOP3 STATE	2	38	.83	38	†
MC74F32D	B FASTQD2I/PORGATE	1	55	.19	55	†	MC74F574DWR2	B OCTDFLIP/FLOP3 STATE	2	1000	.85	1000	†
MC74F32DR2	B FASTQD2I/PORGATE	2	2500	.19	2500	†	MC74F574N	B OCTALD FLIP-FLOP3-STATE	2	18	.81	360	†
MC74F32N	B FASTQD2I/PORGATE	1	25	.19	500	†	MC74F579DW	B 8BIT BIDIR BINARY COUNT	2	38	3.24	38	†

A = OSPD/Power
 B = Analog/Logic
 J = Transportation
 L = Consumer
 N = Networking
 V = Wireless

S = Proprietary Device
 B = Motorola Blue Chip Program Device
 P = Phoenix Program
 ★ = First Time in Book
 † \$200 Minimum Waived

N = Key New Motorola Device
 R = Key "Focus" Motorola Device

1 = Mature, Stable, High-Volume Device
 2 = Moderate-Volume Device
 3 = Low-Volume Device

COMMERCIAL COMPONENTS

Type No.	Grp/Description	Per Unit Sugg. Factory			†	
		Resale Price	Price	Order		
PC	Qty			Incrrmnt		
MC74F579DWR2	B 8BIT BIDIR BINARY COUNT	2	1000	3.24	1000	†
MC74F579N	B 8-BIT BIDIR BINARY CNTR	1	18	3.24	360	†
MC74F623DW	B OCTAL BUS TRANSCEIVER	N	38	1.08	38	†
MC74F623N	B OCTAL BUS TRANSCEIVERS	2	18	1.08	360	†
MC74F640N	B OCTAL BUS TRANSCEIVERS	2	18	1.17	360	†
MC74F646DW	B OCT TRNSCEVR/REGNO-INV3	N	30	2.70	30	†
MC74F646DWR2	B OCT TRNSCEVR/REGNO-INV3	N	1000	2.88	1000	†
MC74F646N	B OCT TRNSCEVR/REGNO-INV3	N	15	2.88	15	†
MC74F657ADW	B OCTAL BIDIRECT TRANSCEIVE	2	30	2.70	30	†
MC74F657AN	B OCTAL REGIST TRANSCEIVER	2	15	2.70	15	†
MC74F74D	B FAST DL POS EDG-TRIG FF	1	55	.34	55	†
MC74F74DR2	B FAST DL POS EDG-TRIG FF	1	2500	.36	2500	†
MC74F74N	B FAST DL POS EDG-TRIG FF	1	25	.31	500	†
MC74F779D	B 8BIT BIDIRECT BINARY	2	48	3.78	48	†
MC74F779DR2	B 8-BIT BIDIRECT BINARY CNT	2	2500	3.78	2500	†
MC74F779N	B 8-BIT BIN BIDIR CNTR	2	25	3.78	500	†
MC74F803D	B QUADD-TYP FLIP/FLOP	2	55	7.68	55	S P †
MC74F803DR2	B D-TYPE FLIP/FLOP	2	2500	7.72	2500	S †
MC74F803N	B QDD-TYPE FLIP/FLOP	2	25	7.65	500	S P †
MC74F823DW	B 9-BIT BUS INTERFACE	2	30	2.20	30	†
MC74F823DWR2	B 9-BIT BUS INTERFACE	2	1000	2.20	1000	†
MC74F823N	B 9-BIT BUS INTERFACEREG	2	15	2.20	15	†
MC74F827DW	B 10 BIT BUF/LINE DRW3 ST	2	30	2.20	30	†
MC74F827N	B 10-BIT BUF/LNDR	2	15	2.20	15	†
MC74F85D	B 4-BIT MAGNITUDE COMP	2	48	1.35	48	†
MC74F85DR2	B 4-BIT MAGNITUDE COMP	2	2500	1.37	2500	†
MC74F85N	B 4-BIT MAGNITUDE COMP	2	25	1.35	500	†
MC74F86D	B FAST QD2/PEXC OR	2	55	.43	55	†
MC74F86DR2	B FAST QD2/PEXC OR R	2	2500	.43	2500	†
MC74F86N	B FAST QD2/PEXC OR	1	25	.43	500	†
MC74HCT00AD	B QUAD2-I NAND GATE W/LSTT	2	55	.17	55	†
MC74HCT00ADR2	B QUAD2 INPUT NOR GATE	2	2500	.17	2500	†
MC74HCT00AN	B QUAD2-I NAND GATE W/LSTT	1	25	.17	500	†
MC74HCT04AD	B HEX INV WTH LSTTL COMP IP	2	55	.17	55	†
MC74HCT04ADR2	B HEX INVERTER	2	2500	.17	2500	†
MC74HCT04AN	B HEX INV WTH LSTTL COMP IP	1	25	.17	500	†
MC74HCT08ADR2	B QUAD2 INPUT AND GATE	N	2500	.17	2500	★ †
MC74HCT08ADT	B QUAD2-INPUT AND GATE	N	96	.17	96	†
MC74HCT08ADTR2	B QUAD2-INPUT AND GATE	2	2500	.19	2500	†
MC74HCT08AN	B QUAD2-I AND GATE W/LSTTL	2	25	.17	500	†
MC74HCT138AD	B DECODER/DEMULTIPLXR1OF8	2	48	.38	48	†
MC74HCT138ADT	B 1-OF-8 DECODER/DEMUX	N	96	.43	96	†
MC74HCT138ADTR2	B 1-OF-8 DECODER/DEMUX	2	2500	.45	2500	†
MC74HCT138AN	B DECODER/DEMULTIPLXR1OF8	1	25	.36	500	†
MC74HCT14AD	B HEXSCHMITT-TRGGR INVRTR	1	55	.32	55	†

Type No.	Grp/Description	Per Unit Sugg. Factory			†	
		Resale Price	Price	Order		
PC	Qty			Incrrmnt		
MC74HCT14ADR2	B HEXSCHMITT-TRGGR INVRTR	2	2500	.34	2500	†
MC74HCT14AN	B HEXSCHMITT-TRGGR INVRTR	1	25	.31	500	†
MC74HCT157ADR2	B SELCTR/MULTIPLXR2-INPT	2	2500	.43	2500	†
MC74HCT157AN	B SELCTR/MULTIPLXR2-INPT	2	25	.40	500	†
MC74HCT163ADR2	B PRESET BINARY SNYCHR CTR	2	2500	.47	2500	†
MC74HCT163AN	B PRESET BINARY SNYCHR CTR	2	25	.43	500	†
MC74HCT174AD	B FLIP/FLOP HEX DW/CLK RST	2	48	.41	48	†
MC74HCT174ADR2	B HEX D FL/FLW/CLK&RESET	2	2500	.43	2500	†
MC74HCT174AN	B FLIP/FLOP HEX DW/CLK RST	2	25	.40	500	†
MC74HCT240ADT	B OCT3 S INV BFR/LN	N	75	.72	75	†
MC74HCT240ADTR2	B OCTAL BUFFER	2	2500	.74	2500	†
MC74HCT240ADW	B IC OCTAL3-ST	2	38	.32	38	†
MC74HCT240ADWR2	B IC OCTAL3-ST	2	1000	.32	1000	†
MC74HCT240AN	B IC OCTAL3-ST	2	18	.32	360	†
MC74HCT244ADT	B QUAD3-S N INV BFR/LN	N	75	.72	75	†
MC74HCT244ADW	B IC CHIP OCTAL3-ST	1	38	.32	38	†
MC74HCT244ADWR2	B IC CHIP OCTAL3-ST	2	1000	.32	1000	†
MC74HCT244AN	B IC CHIP OCTAL3-ST	1	18	.32	360	†
MC74HCT245ADT	B OCT3-S-N INV BUS/TRANS	N	75	.72	75	†
MC74HCT245ADTR2	B OCT3-S-N INV BUS/TRANS	2	2500	.74	2500	†
MC74HCT245ADW	B OCTL3-STNONINVRT BUS TR	1	38	.32	38	†
MC74HCT245ADWR2	B OCTL3-STNONINVRT BUS TR	2	1000	.32	1000	†
MC74HCT245AN	B OCTL3-STNONINVRT BUS TR	1	18	.32	360	†
MC74HCT273ADW	B FLIP-FLOP,D-TYPE, OCTAL	1	38	.32	38	†
MC74HCT273ADWR2	B FLIP-FLOP,D-TYPE, OCTAL	2	1000	.32	1000	†
MC74HCT273AN	B FLIP-FLOP,D-TYPE, OCTAL	1	18	.32	360	†
MC74HCT32AD	B QUAD2-I OR GATE W/LSTTL	2	55	.17	55	†
MC74HCT32ADR2	B QUAD2-I OR GATE W/LSTTL	2	2500	.17	2500	†
MC74HCT32AN	B QUAD2-I OR GATE W/LSTTL	2	25	.17	500	†
MC74HCT373ADT	B OCT3-S-N INV TRANS/LATCH	N	75	.72	75	†
MC74HCT373ADTR2	B OCTAL LATCH	2	2500	.74	2500	†
MC74HCT373ADW	B MONOLITHIC OCT3-STNONIN	1	38	.32	38	†
MC74HCT373ADWR2	B LATCHD-NONINVRT3-ST OCT	2	1000	.32	1000	†
MC74HCT373AN	B MONOLITHIC OCT3-STNONIN	1	18	.32	360	†
MC74HCT374ADT	B OCT3-S-N INV FLIP FLOP	N	75	.72	75	†
MC74HCT374ADTR2	B OCT3-S-N INV FLIP FLOP	2	2500	.74	2500	†
MC74HCT374ADW	B OCTL3-STNONINVRT D-TYPE	2	38	.32	38	†
MC74HCT374ADWR2	B FLIP/FLOP NONINVRT3-ST	2	1000	.32	1000	†
MC74HCT374AN	B HSL OCTLD-FF3ST TTL COMP	1	18	.32	360	†
MC74HCT541ADW	B OT3-ST NVRT/BFL/DR/LRC	N	38	.70	38	†
MC74HCT541ADWR2	B OT3-ST NVRT/BFL/DR/LRC	N	1000	.72	1000	†
MC74HCT541AN	B OT3-ST NVRT/BFL/DR/LRC	1	18	.68	360	†
MC74HCT573ADW	B OCTL3-STNONINVRT D-TYP	2	38	.74	38	†
MC74HCT573ADWR2	B OCTL3-STNONINVRT D-TYPE	2	1000	.76	1000	†
MC74HCT573AN	B OCTL3-STNONINVRT D-TYP	1	18	.72	360	†

A = OSPD/Power
 B = Analog/Logic
 J = Transportation
 L = Consumer
 N = Networking
 V = Wireless

S = Proprietary Device
 B = Motorola Blue Chip Program Device
 P = Phoenix Program
 ★ = First Time in Book
 † \$200 Minimum Waived

N = Key New Motorola Device
 R = Key "Focus" Motorola Device

1 = Mature, Stable, High-Volume Device
 2 = Moderate-Volume Device
 3 = Low-Volume Device

COMMERCIAL COMPONENTS

Type No.	Grp/Description	Per Unit Sugg. Factory		Order	Incmt		Type No.	Grp/Description	Per Unit Sugg. Factory		Order	Incmt	
		PC	Qty						Price	Price			PC
MC74HCT574ADW	B OCTL3-SN-INVTD FL/FL	2	38	.70	38	†	MC74HC126AD	B QUAD3STNONINVERTING BUF	2	55	.47	55	†
MC74HCT574ADWR2	B OCTL3-ST FL/FLNONINVRT	2	1000	.72	1000	†	MC74HC126ADR2	B QUAD3STNONINVERTIN BUF	2	2500	.49	2500	†
MC74HCT574AN	B OCTL3-SN-INVTD FL/FL	1	18	.68	360	†	MC74HC126AN	B QUAD3STNONINVERTING BUF	1	25	.45	500	†
MC74HCT74AD	B DUAL FL/FL W/SET & RESET	2	55	.29	55	†	MC74HC132AD	B QD2-INPT NAND GATE W/SCH	1	55	.52	55	†
MC74HCT74ADR2	B DUAL FL/FL W/SET & RESET	2	2500	.31	2500	†	MC74HC132ADR2	B QD2-INPT NAND GATE W/SCH	2	2500	.54	2500	†
MC74HCT74AN	B DUAL FL/FL W/SET & RESET	1	25	.27	500	†	MC74HC132ADT	B QD2-INPUT NAND GATE W/SC	N	96	.86	96	†
MC74HC004AD	B HSL HEX UNBUFFERED INV	N	55	.17	55	†	MC74HC132AN	B QD2-INPT NAND GATE W/SCH	1	25	.50	500	†
MC74HC004ADR2	B HSL HEX UNBUFFERED INV	2	2500	.17	2500	†	MC74HC133N	B HSL13-INAND GATE	2	25	.50	500	†
MC74HC004AN	B HSL HEX UNBUFFERED INV	N	25	.17	500	†	MC74HC137D	B HSL1OF8DEC/DEMUXAD/LAT	2	48	.52	48	†
MC74HC00AD	B GATE NAND GATE2-I	1	55	.17	55	†	MC74HC137N	B HSL1OF8DEC/DEMUXAD/LAT	2	25	.50	500	†
MC74HC00ADR2	B QUAD,2-INPUT NAND GATE	1	2500	.17	2500	†	MC74HC138AD	B DECODER/DEMULTIPLX1OF8	1	48	.38	48	†
MC74HC00ADT	B NAND GATE	N	96	.17	96	†	MC74HC138ADR2	B DECDR/DEMULTIPLXR1OF8	2	2500	.40	2500	†
MC74HC00ADTR2	B NAND GATE	2	2500	.19	2500	†	MC74HC138AN	B DECODER/DEMULTIPLX1OF8	1	25	.36	500	†
MC74HC00AN	B GATE NAND GATE2-I	1	25	.17	500	†	MC74HC139AD	B DECODER,10F4DUAL	2	48	.40	48	†
MC74HC02AD	B QUAD2-INNOR GATE	1	55	.17	55	†	MC74HC139ADR2	B DECODER/DEMULTIPLXER	2	2500	.41	2500	†
MC74HC02ADR2	B QUAD,2-INPUT NOR GATE	1	2500	.17	2500	†	MC74HC139AN	B DECODER,10F4DUAL	1	25	.38	500	†
MC74HC02ADT	B NORQUAD2-INPUT	N	96	.17	96	†	MC74HC14AD	B HEXSCHMITT INVERTER	1	55	.32	55	†
MC74HC02ADTR2	B NORQUAD2-INPUT	2	2500	.19	2500	†	MC74HC14ADR2	B HEXSCHMITT INVERTER	1	2500	.34	2500	†
MC74HC02AN	B NORQUAD2-INPUT	1	25	.17	500	†	MC74HC14ADT	B HEXSCHMITT TRGGER INVERT	N	96	.67	96	†
MC74HC03AD	B QD2-IN NAND GATE W/DRAIN	1	55	.17	55	†	MC74HC14AN	B HEXSCHMITT INVERTER	1	25	.31	500	†
MC74HC03ADR2	B QD2-IN NAND GATE W/DRAIN	2	2500	.17	2500	†	MC74HC147D	B DEC. TOBCPPRIORITY ENCD	2	48	.50	48	†
MC74HC03AN	B GATE,NAND,2-IQUAD	1	25	.17	500	†	MC74HC147N	B HSL DEC TOBCDPRIORIENC	2	25	.49	500	†
MC74HC04AD	B HSL HEX INVERTER	1	55	.17	55	†	MC74HC151DR2	B HSL8-INPT DATA SEL/MUX	2	2500	.52	2500	†
MC74HC04ADR2	B HEX INVRTR	1	2500	.17	2500	†	MC74HC151N	B HSL8-I DATA SEL/MUX	1	25	.38	500	†
MC74HC04ADT	B HEX INVERTER	N	96	.17	96	†	MC74HC153D	B HSL DUAL4-I DATA SEL/MUX	2	48	.41	48	†
MC74HC04ADTR2	B HEX INVERTER	2	2500	.19	2500	†	MC74HC153DR2	B HSL DL4-INP DATA SEL/MUX	2	2500	.43	2500	†
MC74HC04AN	B HSL HEX INVERTER	1	25	.17	500	†	MC74HC153N	B HSL DUAL4-I DATA SEL/MUX	1	25	.40	500	†
MC74HC08AD	B QUAD,2-INPUT NAND GATE	1	55	.17	55	†	MC74HC154DW	B HSL1-16DECODER/DEMUX	1	30	1.71	30	†
MC74HC08ADR2	B QUAD,2-INPUT NAND GATE	1	2500	.17	2500	†	MC74HC154DWR2	B HSL1-16DECODER/DEMUX	2	1000	1.73	1000	†
MC74HC08ADT	B QUAD2-INPUT AND GATE	N	96	.17	96	†	MC74HC154N	B HSL1-16DECODER/DEMUX	1	15	1.35	15	†
MC74HC08ADTR2	B QUAD2-INPUT AND GATE	2	2500	.19	2500	†	MC74HC157AD	B DTA SELECTOR/MLTIPLX2-IQ	2	48	.41	48	†
MC74HC08AN	B QUAD2 INPUT & GATE	1	25	.17	500	†	MC74HC157ADR2	B DTA SELECTOR/MLTIPLX2-1 Q	2	2500	.43	2500	†
MC74HC10D	B HSL TRIPLE3-INAND GATE	2	55	.17	55	†	MC74HC157ADT	B DATA SELECTOR	N	96	.70	96	†
MC74HC10DR2	B TRIPLE3-IN AND GATE	2	2500	.17	2500	†	MC74HC157ADTR2	B DATA SELECTOR	2	2500	.72	2500	†
MC74HC10N	B HSL TRIPLE3-INAND GATE	1	25	.17	500	†	MC74HC157AN	B DTA SELECTOR/MLTIPLX2-IQ	1	25	.40	500	†
MC74HC107D	B DUAL4-BBINARY CNTR	2	55	.43	55	†	MC74HC161AD	B CNTR, BINRY,4-BASYNCHR	2	48	.47	48	†
MC74HC107DR2	B DUAL4-BBINARY CNTR	2	2500	.45	2500	†	MC74HC161ADR2	B CNTR, BINRY,4-BASYNCHR	2	2500	.49	2500	†
MC74HC107N	B HSL DUAL JK-FF W/RESET	2	25	.41	500	†	MC74HC161AN	B CNTR, BINRY,4-BASYNCHR	1	25	.45	500	†
MC74HC11D	B HSL TRIPLE3-IAND GATE	2	55	.17	55	†	MC74HC163AD	B COUNTER,DECADE,BCD	2	48	.47	48	†
MC74HC11DR2	B HSL TRIPLE3-1 AND GATE	2	2500	.17	2500	†	MC74HC163ADR2	B COUNTER,DECADE,BCD	2	2500	.49	2500	†
MC74HC11N	B HSL TRIPLE3-IAND GATE	1	25	.17	500	†	MC74HC163AN	B COUNTER,DECADE,BCD	1	25	.45	500	†
MC74HC125AD	B BUF,NON-INVERTING3-ST	1	55	.40	55	†	MC74HC164AD	B SHIFT8BIT SERINPT/OTPT	N	55	.41	55	†
MC74HC125ADR2	B BUFFERNON-INVRT3-ST	2	2500	.41	2500	†	MC74HC164ADR2	B SHIFT8BIT SERINPT/OTPT	2	2500	.41	2500	†
MC74HC125ADT	B QUADBUFFER	N	96	.74	96	†	MC74HC164AN	B HSL8-BIT SI/PO S/R	N	25	.41	500	†
MC74HC125AN	B BUF,NON-INVERTING3-ST	1	25	.38	500	†	MC74HC165D	B HSL8-BIT SI/PO S/R	1	48	.47	48	†

A = OSPD/Power
 B = Analog/Logic
 J = Transportation
 L = Consumer
 N = Networking
 V = Wireless

S = Proprietary Device
 B = Motorola Blue Chip Program Device
 P = Phoenix Program
 * = First Time in Book
 † \$200 Minimum Waived

N = Key New Motorola Device
 R = Key "Focus" Motorola Device

1 = Mature, Stable, High-Volume Device
 2 = Moderate-Volume Device
 3 = Low-Volume Device

EFFECTIVE DATE: JANUARY 10, 1998

COMMERCIAL COMPONENTS

Type No.	Grp/Description	Per Unit Sugg.		Factory Order		
		Resale Price	Price			
PC	Qty		Incrrmnt			
MC74HC165DR2	B 8BIT SER-IN/PAR-OUT SHIFT	2	2500	.49	2500	†
MC74HC165N	B HSL8-BIT SI/PO/S/R	1	25	.45	500	†
MC74HC173D	B HSLQUAD3-ST D-FF	2	48	.52	48	†
MC74HC173N	B HSLQUAD3-ST D-FF	2	25	.50	500	†
MC74HC174AD	B FLIP/FLOP HEX DW/CLOCK	2	48	.41	48	†
MC74HC174ADR2	B FLIP/FLOP HEX DW/CLOCK	2	2500	.43	2500	†
MC74HC174AN	B FLIP/FLOP HEX DW/CLOCK	1	25	.40	500	†
MC74HC175D	B HSLQUADD-FF	1	48	.40	48	†
MC74HC175DR2	B HSLQDD-FF CLK/RESET	2	2500	.41	2500	†
MC74HC175N	B HSLQUADD-FF	1	25	.38	500	†
MC74HC20N	B HSLDUAL4-INAND GATE	1	25	.17	500	†
MC74HC237N	B HSL1-OF-8DEC/DEMUX/LAT	1	25	.54	500	†
MC74HC240ADT	B OCTAL BUFFER	N	75	.72	75	†
MC74HC240ADTR2	B OCTAL BUFFER	2	2500	.74	2500	†
MC74HC240ADW	B HSL OCTAL3-ST DRVR	2	38	.32	38	†
MC74HC240ADWR2	B OCTAL BUF/LINE DRV	2	1000	.32	1000	†
MC74HC240AN	B HSL OCTAL3-ST DRVR	1	18	.32	360	†
MC74HC241ADW	B HSL OCTAL3-ST DRVR	2	38	.32	38	†
MC74HC241ADWR2	B HSL OCTL3-ST DRVR	2	1000	.32	1000	†
MC74HC241AN	B HSL OCTAL3-ST DRVR	2	18	.32	360	†
MC74HC244ADT	B OCTAL BUFFER	N	75	.72	75	†
MC74HC244ADW	B HSL OCTAL3-ST DRVR	1	38	.32	38	†
MC74HC244ADWR2	B QUAD3SIN-INV BFR/LN DRVR	1	1000	.32	1000	†
MC74HC244AN	B HSL OCTAL3-ST DRVR	1	18	.32	360	†
MC74HC245ADT	B OCT3-S-NINVBUS/TRANS	N	75	.72	75	†
MC74HC245ADTR2	B OCT3-S-NINVBUS/TRANS	2	2500	.74	2500	†
MC74HC245ADW	B HSL OCTAL3-ST BUS TRANSC	1	38	.32	38	†
MC74HC245ADWR2	B HSL OCT3-SN-INV BUSTRAN	2	1000	.32	1000	†
MC74HC245AN	B HSL OCTAL3-ST BUS TRANSC	1	18	.32	360	†
MC74HC251D	B HSL8-I3-ST DATA SEL/MUX	2	48	.41	48	†
MC74HC251DR2	B HSL8-I3-ST DATA SEL/MUX	2	2500	.43	2500	†
MC74HC251N	B HSL8-I3-ST DATA SEL/MUX	1	25	.40	500	†
MC74HC253D	B HSL DUAL4-I3-ST MUX	2	48	.49	48	†
MC74HC253DR2	B HSL DUAL4-I3-ST MUX	2	2500	.50	2500	†
MC74HC253N	B HSL DUAL4-I3-ST MUX	2	25	.47	500	†
MC74HC257D	B HSLQUAD2-IDATA SEL/MUX	2	48	.45	48	†
MC74HC257DR2	B QUAD2-INMUX	2	2500	.47	2500	†
MC74HC257N	B HSLQUAD2-IDATA SEL/MUX	2	25	.43	500	†
MC74HC259D	B HSL8-BIT LATCH/DECODER	1	48	.58	48	†
MC74HC259DR2	B 8-BIT ADDRESS-LTCH	2	2500	.59	2500	†
MC74HC259N	B HSL8-BIT LATCH/DECODER	1	25	.56	500	†
MC74HC27N	B HSL TRIPLE3-INOR GATE	1	25	.17	500	†
MC74HC273ADW	B OCTLD-TYPE FLIP/FLOP	1	38	.32	38	†
MC74HC273ADWR2	B OCTALD-TYPE FLIP/FLOP	1	1000	.32	1000	†
MC74HC273AN	B OCTLD-TYPE FLIP/FLOP	1	18	.32	360	†

Type No.	Grp/Description	Per Unit Sugg.		Factory Order		
		Resale Price	Price			
PC	Qty		Incrrmnt			
MC74HC280D	B HSL9-BIT PARITY GEN/CHK	2	55	.56	55	†
MC74HC280DR2	B HSL9-BIT PARITY GEN/CHK	2	2500	1.21	2500	†
MC74HC280N	B HSL9-BIT PARITY GEN/CHK	2	25	.54	500	†
MC74HC299DW	B HSL8-BIT PARITY GEN/CHK	2	38	.88	38	†
MC74HC299DWR2	B HSL8-BIT PARITY GEN/CHK	2	1000	.90	1000	†
MC74HC299N	B HSL8BIT BIDIRECT UNIVS/R	2	18	.86	360	†
MC74HC30D	B HSL8-INAND GATE	2	55	.17	55	†
MC74HC30DR2	B 8-IN NAND GATE	2	2500	.17	2500	†
MC74HC30N	B HSL8-INAND GATE	1	25	.17	500	†
MC74HC32AD	B 2-I, QUAD OR GATE	1	55	.17	55	†
MC74HC32ADR2	B QUAD,2-INPUT OR GATE	1	2500	.17	2500	†
MC74HC32ADT	B 2-INPUT OR GATE	N	96	.17	96	†
MC74HC32ADTR2	B 2-INPUT OR GATE	2	2500	.19	2500	†
MC74HC32AN	B 2-I, QUAD OR GATE	1	25	.17	500	†
MC74HC365N	B HSL HEX3-ST BUFFER	1	25	.58	500	†
MC74HC367N	B HSL HEX3-ST BUFFER	2	25	.54	500	†
MC74HC373ADT	B OCTAL LATCH	N	75	.72	75	†
MC74HC373ADTR2	B OCTAL LATCH	2	2500	.74	2500	†
MC74HC373ADW	B OCT TRANSP LTCH3-ST	1	38	.32	38	†
MC74HC373ADWR2	B OCTL3-ST LTCH, NONINVRT	1	1000	.32	1000	†
MC74HC373AN	B OCT TRANSP LTCH3-ST	1	18	.32	360	†
MC74HC374ADT	B OCTAL DFF	N	75	.72	75	†
MC74HC374ADTR2	B OCTAL DFF	2	2500	.74	2500	†
MC74HC374ADW	B FLIP-FLOP, OCT D,3-ST	1	38	.32	38	†
MC74HC374ADWR2	B OCTL3-ST FL/FLNONINVRT	2	1000	.32	1000	†
MC74HC374AN	B FLIP-FLOP, OCT D,3-ST	1	18	.32	360	†
MC74HC390D	B BIN CNTR WITH 2&5 SECT	2	48	.58	48	†
MC74HC390DR2	B BIN CNTR WITH 2&5 SECT	2	2500	.58	2500	†
MC74HC390N	B HSL DUAL BIN RIPPLE CNTR	1	25	.54	500	†
MC74HC393D	B DUAL4-B BINARY CNTR	1	55	.56	55	†
MC74HC393DR2	B DUAL4-B BINARY CNTR	2	2500	.58	2500	†
MC74HC393N	B HSL DUAL BIN RIPPLE CNTR	1	25	.54	500	†
MC74HC4002D	B HSL DUAL4-INOR GATE	2	55	.31	55	†
MC74HC4002DR2	B HSL DUAL4-1 NOR GATE	2	2500	.32	2500	†
MC74HC4002N	B HSL DUAL4-INOR GATE	2	25	.29	500	†
MC74HC4017D	B HSL DECADE CNTR/DVDR	2	48	.58	48	†
MC74HC4017DR2	B HSL DECADE CNTR/DVDR	2	2500	.59	2500	†
MC74HC4017N	B HSL DECADE CNTR/DVDR	1	25	.56	500	†
MC74HC4020AD	B MONOLITHIC WFR, BINRY CNTR	N	48	.49	48	†
MC74HC4020AN	B MONOLITHIC WFR, BIN14BIT	1	25	.61	500	†
MC74HC4024D	B HSL7-ST BIN RIPPLE CNTR	2	55	.49	55	†
MC74HC4024DR2	B HSL7-STG BIN RIPPLE CNTR	2	2500	.50	2500	†
MC74HC4024N	B HSL7-ST BIN RIPPLE CNTR	1	25	.47	500	†
MC74HC4040AD	B MONOLITHIC WFR, CNTR, BINAR	N	48	.58	48	†
MC74HC4040AN	B MONOLITHIC WFR, BIN12BIT	1	25	.58	500	†

A = OSPD/Power
 B = Analog/Logic
 J = Transportation
 L = Consumer
 N = Networking
 V = Wireless

S = Proprietary Device
 B = Motorola Blue Chip Program Device
 P = Phoenix Program
 * = First Time in Book
 † \$200 Minimum Waived

N = Key New Motorola Device
 R = Key "Focus" Motorola Device

1 = Mature, Stable, High-Volume Device
 2 = Moderate-Volume Device
 3 = Low-Volume Device

COMMERCIAL COMPONENTS

Type No.	Grp/Description	Per Unit Sugg. Factory		PC	Qty	Price	Order	Incrrmnt	Type No.	Grp/Description	Per Unit Sugg. Factory		PC	Qty	Price	Order	Incrrmnt	
		Resale	Price								Resale	Price						
MC74HC4046AD	B PHASELOCKED LOOP W/VCO	1	48	1.04	48	†			MC74HC4538ADR2	B MULTIVI PRECIS MONSTB DUA	2	2500	.72	2500	†			
MC74HC4046ADR2	B PHASELOCKED LOOP W/VCO	2	2500	1.06	2500	†			MC74HC4538AN	B MULTIVI PRECIS MONSTB DUA	1	25	.68	500	†			
MC74HC4046AN	B PHASELOCKED LOOP W/VCO	1	25	1.03	500	†			MC74HC4851AD	B 8:1 MUX/DEMUX W/INJ/CU/CON	N	48	1.44	48	S	†		
MC74HC4049D	B HSL HEX LOGIC LEVEL CONV	2	48	.52	48	†			MC74HC4852AD	B DUAL 4:1 MUX/DEMUX W/INJ.	N	48	1.44	48	S	†		
MC74HC4049DR2	B HSL HEX LOGIC LEVEL CONV.	2	2500	.54	2500	†			MC74HC534AN	B FFD OCTAL 3-ST INV	2	18	.68	360	†			
MC74HC4049N	B HSL HEX LOGIC LEVEL CONV	2	25	.50	500	†			MC74HC540ADW	B OT3-ST NVRT/BFL/DR/L/RC	N	38	.68	38	†			
MC74HC4050D	B HSL HEX LOGIC LEVEL CONV	2	48	.52	48	†			MC74HC540ADWR2	B OT3-ST NVRT/BFL/DR/L/RC	N	1000	.70	1000	†			
MC74HC4050DR2	B HSL HEX LOGIC LEVEL CONV.	2	2500	.54	2500	†			MC74HC540AN	B OT3-ST NVRT/BFL/DR/L/RC	N	18	.67	360	†			
MC74HC4050N	B HSL HEX LOGIC LEVEL CONV	1	25	.50	500	†			MC74HC541ADW	B OT3-ST NVRT/BFL/DR/L/RC	N	38	.70	38	†			
MC74HC4051D	B HSL 8-CHANALOG MUX/DEMUX	N	48	.90	48	†			MC74HC541ADWR2	B OT3-ST NVRT/BFL/DR/L/RC	1	1000	.72	1000	†			
MC74HC4051DR2	B HSL 8-CHANALOG MUX/DEMUX	N	2500	.94	2500	†			MC74HC541AN	B OT3-ST NVRT/BFL/DR/L/RC	1	18	.68	360	†			
MC74HC4051DW	B HSL 8-CHANALOG MUX/DEMUX	1	47	.67	47	†			MC74HC563ADW	B OCT3 ST INVERT TRANSLCH	N	38	.65	38	†			
MC74HC4051DWR2	B HSL 8-CHANALOG MUX/DEMUX	2	1000	.68	1000	†			MC74HC563ADWR2	B OCT3 ST INVERT TRANSLCH	2	1000	.65	1000	†			
MC74HC4051N	B HSL 8-CHANALOG MUX/DEMUX	1	25	.65	500	†			MC74HC563AN	B OCT3 STATE INVERT TRAN LCH	N	18	.65	360	†			
MC74HC4052D	B HSL DL4-CHALG MUX/DEMUX	N	48	.90	48	†			MC74HC573ADT	B OCT3-S-INV TRANS/LTCH	N	75	.72	75	†			
MC74HC4052DR2	B HSL DL4-CHALG MUX/DEMUX	N	2500	.94	2500	†			MC74HC573ADTR2	B OCT3-S-INV TRANS/LTCH	2	2500	.74	2500	†			
MC74HC4052DT	B DUAL 4-CHANALOG MUX/DEMUX	N	96	.99	96	†			MC74HC573ADW	B OCTL3-ST, NONINV RT-D-TYP	1	38	.68	38	†			
MC74HC4052DW	B HSL DL4-CHALG MUX/DEMUX	1	47	.65	47	†			MC74HC573ADWR2	B OCTL3-ST, NONINV RT-D-TYP	2	1000	.70	1000	†			
MC74HC4052DWR2	B HSL DL4-CHALG MUX/DEMUX	2	1000	.67	1000	†			MC74HC573AN	B OCTL3-ST, NONINV RT-D-TYP	1	18	.67	360	†			
MC74HC4052N	B HSL DL4-CHALG MUX/DEMUX	1	25	.63	500	†			MC74HC574ADW	B OCTL3-ST N-INV RT D FL/FL	1	38	.70	38	†			
MC74HC4053D	B MULTIPLEXER/DEMULTIPLEXER	N	48	.90	48	†			MC74HC574ADWR2	B OCTL3-ST FL/FL NONINV RT	2	1000	.72	1000	†			
MC74HC4053DT	B TRIPLE 2 CH ANALOG MUX	N	96	1.01	96	†			MC74HC574AN	B OCTL3-ST N-INV RT D FL/FL	1	18	.68	360	†			
MC74HC4053DW	B HSL TRPL 2CH ALG MUX/DEMUX	1	47	.67	47	†			MC74HC589AD	B 8/BIT SHIFT REGISTER	N	48	1.17	48	†			
MC74HC4053DWR2	B HSL TRPL 2CH ALG MUX/DMUX	2	1000	.68	1000	†			MC74HC589ADR2	B 8/BIT SHIFT REGISTER	2	2500	1.17	2500	†			
MC74HC4053N	B HSL TRPL 2CH ALG MUX/DEMUX	1	25	.65	500	†			MC74HC589AN	B 8/BIT SHIFT REGISTER	N	25	1.17	500	†			
MC74HC4060AD	B HSL 14-ST BINARY CNTR/OSC	N	48	.61	48	†			MC74HC595AD	B SHIFT REG. 3-STATE	1	48	.74	48	†			
MC74HC4060ADR2	B 14-STG BINARY RIPPLE COUN	2	2500	.63	2500	†			MC74HC595ADR2	B SHIFT REG. 3-STATE	1	2500	.76	2500	†			
MC74HC4060AN	B HSL 14-ST BINARY CNTR/OSC	N	25	.58	500	†			MC74HC595AN	B SHIFT REG. 3-STATE	1	25	.72	500	†			
MC74HC4066D	B HSL QD ANALOG SWITCH MUX	1	55	.52	55	†			MC74HC597AD	B 8/BIT SHIFT REGISTER	N	48	.47	48	†			
MC74HC4066DR2	B HSL QD ANALOG SWITCH MUX	1	2500	.54	2500	†			MC74HC597ADR2	B 8/BIT SHIFT REGISTER	N	2500	.47	2500	†			
MC74HC4066N	B HSL QD ANALOG SWITCH MUX	1	25	.50	500	†			MC74HC597AN	B 8/BIT SHIFT REGISTER	N	25	.47	500	†			
MC74HC4075D	B HSL TRIPLE 3-1 OR GATE	2	55	.34	55	†			MC74HC640ADW	B HSL OCTAL 3-ST INV TRANS	2	38	.92	38	†			
MC74HC4075DR2	B HSL TRIPLE 3-1 OR GATE	2	2500	.36	2500	†			MC74HC640ADWR2	B TRANSCVR, BUS, INVERT 3-ST	2	1000	.94	1000	†			
MC74HC4075N	B HSL TRIPLE 3-1 OR GATE	2	25	.32	500	†			MC74HC640AN	B HSL OCTAL 3-ST INV TRANS	N	18	.83	360	†			
MC74HC4078D	B HSL 8-1 NOR/OR GATE	2	55	.45	55	†			MC74HC646N	B HSL OCTAL 3-ST NI TRANS	2	15	2.66	15	†			
MC74HC4078DR2	B HSL 8-1 NOR/OR GATE	2	2500	.47	2500	†			MC74HC688DW	B HSL 8-BIT EQUALITY COMPAR	2	38	.72	38	†			
MC74HC4078N	B HSL 8-1 NOR/OR GATE	1	25	.41	500	†			MC74HC688DWR2	B HSL 8-BIT EQUAL COMPARAT	2	1000	.74	1000	†			
MC74HC42N	B HSL 10F10 DECODER	2	25	.47	500	†			MC74HC688N	B HSL 8-BIT EQ COMP	1	18	.70	360	†			
MC74HC4316D	B HSL QD ANALOG SWITCH MUX	2	48	.56	48	†			MC74HC73N	B HSL DUAL JK-FW/RESET	2	25	.47	500	†			
MC74HC4316DR2	B MOS QD W/LEVEL XLATOR	2	2500	.58	2500	†			MC74HC74AD	B FFD TYPE DUAL	1	55	.29	55	†			
MC74HC4316N	B HSL QD ANALOG SWITCH MUX	2	25	.54	500	†			MC74HC74ADR2	B FFD-TYPE DUAL	1	2500	.31	2500	†			
MC74HC4351N	B HSL 8-CHALG MUX/DEMUX	2	18	.68	360	†			MC74HC74ADT	B D FLIP FLOP	N	96	.35	96	†			
MC74HC4514DWR2	B HSL 1 OF 16 DECODER/DEMUX	2	1000	1.49	1000	†			MC74HC74ADTR2	B D FLIP FLOP	2	2500	.37	2500	†			
MC74HC4514N	B HSL 1 OF 16 DECODER/DEMUX	1	15	1.46	15	†			MC74HC74AN	B FFD TYPE DUAL	1	25	.27	500	†			
MC74HC4538AD	B MULTIVI PRECIS MONSTB DUA	1	48	.70	48	†			MC74HC75N	B HSL DUAL 2-BIT TRANSLAT	2	25	.41	500	†			

A = OSPD/Power
 B = Analog/Logic
 J = Transportation
 L = Consumer
 N = Networking
 V = Wireless

S = Proprietary Device
 B = Motorola Blue Chip Program Device
 P = Phoenix Program
 * = First Time in Book
 † = \$200 Minimum Waived

N = Key New Motorola Device
 R = Key "Focus" Motorola Device

1 = Mature, Stable, High-Volume Device
 2 = Moderate-Volume Device
 3 = Low-Volume Device

EFFECTIVE DATE: JANUARY 10, 1998

COMMERCIAL COMPONENTS

Type No.	Grp/Description	Per Unit Sugg.		Factory Order	Incrmnt	
		Resale Price	Price			
MC74HC85N	B HSL4-BIT MAG COMP	1	25	.63	500	†
MC74HC86AD	B HSLQUAD2-1EX-ORGATE	N	55	.32	55	†
MC74HC86ADR2	B HSLQUAD2-1EX-ORGATE	2	2500	.32	2500	†
MC74HC86AN	B HSLQUAD2-1EX-ORGATE	N	25	.32	25	†
MC74LCX00D	B 3.3VQUAD2-INPUT NANDGT	N	55	.50	55	†
MC74LCX00DR2	B 3.3VQUAD2-INPUT NANDGT	2	2500	.50	2500	†
MC74LCX00DT	B 3.3VQUAD2-INPUT NANDGT	N	96	.50	96	†
MC74LCX00DTR2	B 3.3VQUAD2-INPUT NANDGT	N	2500	.92	2500 *	†
MC74LCX02D	B 3.3VQUAD2-INPT NAND GATE	N	55	.50	55	†
MC74LCX02DR2	B 3.3VQUAD2-INPT NAND GATE	2	2500	.50	2500	†
MC74LCX02DT	B 3.3VQUAD2-INPT NAND GATE	N	96	.50	96	†
MC74LCX02DTR2	B 3.3VQUAD2-INPT NAND GATE	N	2500	.92	2500 *	†
MC74LCX04D	B 3.3VHEXINVERTER	N	55	.50	55	†
MC74LCX04DR2	B 3.3VHEXINVERTER	2	2500	.50	2500	†
MC74LCX04DT	B 3.3VHEXINVERTER	N	96	.50	96	†
MC74LCX04DTR2	B 3.3VHEXINVERTER	N	2500	.92	2500 *	†
MC74LCX08D	B 3.3VQUAD2-INPT NAND GATE	N	55	.50	55	†
MC74LCX08DR2	B 3.3VQUAD2-INPT NAND GATE	2	2500	.50	2500	†
MC74LCX08DT	B 3.3VQUAD2-INPT NAND GATE	N	96	.50	96	†
MC74LCX08DTR2	B 3.3VQUAD2-INPT NAND GATE	N	2500	.92	2500 *	†
MC74LCX125D	B 3.3VQUAD BUFF	N	55	.67	55	†
MC74LCX125DR2	B 3.3VQUAD BUFF	2	2500	.67	2500	†
MC74LCX125DT	B 3.3VQUAD BUFF	N	96	.83	96	†
MC74LCX125DTR2	B 3.3VQUAD BUFF	2	2500	.83	2500	†
MC74LCX138D	B 3.3V1/8DECODR/DEMULPLX	N	48	.58	48	†
MC74LCX138DT	B 3.3V1/8DECODR/DEMULPLX	N	96	.58	96	†
MC74LCX157D	B 3.3VQUAD2-INPT MULT PLX	N	48	.58	48	†
MC74LCX157DT	B 3.3VQUAD2-INPT MULT PLX	N	96	.58	96	†
MC74LCX16240ADT	B 16B BUF INPT OUP T	N	39	2.16	39	†
MC74LCX16244DT	B 3.3V16-BIT TRANSCVER	N	39	2.16	39	†
MC74LCX16244DTR2	B 3.3V16-BIT TRANSCVER	2	2500	2.16	2500	†
MC74LCX16245DT	B 3.3V16BIT TRANSCIEVER	N	39	2.16	39	†
MC74LCX16245DTR2	B 3.3V16BIT TRANSCIEVER	2	2500	2.16	2500	†
MC74LCX16373DT	B 16B NNV3S3.3V TRSPRNT	N	39	2.16	39	†
MC74LCX16373DTR2	B 16B NNV3S3.3V TRSPRNT	2	2500	2.16	2500	†
MC74LCX16374DT	B 16B NNV3S3.3V DFLP/FOP	N	39	2.16	39	†
MC74LCX16374DTR2	B 16B NNV3S3.3V DFLP/FOP	2	2500	2.16	2500	†
MC74LCX16543ADT	B 16B NNV3S3.3V LTCH/RECV	N	35	4.23	35	†
MC74LCX16543ADTR	B 16B NNV3S3.3V LTCH/RECV	N	2500	4.23	2500	†
MC74LCX16646DT	B 16B NNV3S3.3V TRSCVRRV	N	35	4.42	35	†
MC74LCX240DT	B 8BINV3S3.3V	N	75	.90	75	†
MC74LCX240DW	B 8BINV3S3.3V	N	38	.90	38	†
MC74LCX244DT	B 8BINV3S3.3V BUFFER	N	75	.90	75	†
MC74LCX244DW	B 8BINV3S3.3V BUFFER	N	38	.90	38	†
MC74LCX245DT	B 8BINV3S3.3V XCVR	N	75	.90	75	†

Type No.	Grp/Description	Per Unit Sugg.		Factory Order	Incrmnt	
		Resale Price	Price			
MC74LCX245DW	B 8BINV3S3.3V XCVR	N	38	.99	38	†
MC74LCX32D	B 3.3VQUAD2-INPT OR GATE	N	55	.50	55	†
MC74LCX32DR2	B 3.3VQUAD2-INPT OR GATE	2	2500	.50	2500	†
MC74LCX32DT	B 3.3VQUAD2-INPT OR GATE	N	96	.50	96	†
MC74LCX32DTR2	B 3.3VQUAD2-INPT OR GATE	N	2500	.92	2500 *	†
MC74LCX373DT	B 8BINV3S3.3V LATCH	N	75	.90	75	†
MC74LCX373DW	B 8BINV3S3.3V	N	38	.90	38	†
MC74LCX374DT	B 8BINV3S3.3V FLIP FLOP	N	75	.90	75	†
MC74LCX374DW	B 8BINV3S3.3V FLIP FLOP	N	38	.90	38	†
MC74LCX540DT	B 8BINV3S3.3V BUFFER	N	75	.90	75	†
MC74LCX540DW	B 8BINV3S3.3V BUFFER	N	38	.90	38	†
MC74LCX541DT	B 8BINV3S3.3V BUFFER	N	75	.90	75	†
MC74LCX541DW	B 8BINV3S3.3V BUFFER	N	38	.90	38	†
MC74LCX573DT	B 8BINV3S3.3V FLIP FLOP	N	75	.90	75	†
MC74LCX573DW	B 8BINV3S3.3V FLIP FLOP	N	38	.90	38	†
MC74LCX574DT	B 8BINV3S3.3V FLIP FLOP	N	75	.90	75	†
MC74LCX574DW	B 8BINV3S3.3V FLIP FLOP	N	38	.90	38	†
MC74LCX652DW	B 8BINV3S3.3V FLIP FLOP	N	30	2.34	30	†
MC74LCX652DWR2	B 8BINV3S3.3V FLIP FLOP	N	1000	2.34	1000	†
MC74LCX74D	B 3.3V DUAL D TYP FLIP FLOP	N	55	.72	55	†
MC74LCX74DR2	B 3.3V DUAL D TYP FLIP FLOP	2	2500	.72	2500	†
MC74LCX74DT	B 3.3V DUAL D TYP FLIP FLOP	N	96	.81	96	†
MC74LCX74DTR2	B 3.3V DUAL D TYP FLIP FLOP	2	2500	.81	2500	†
MC74LVQ00D	B LOW VOL Q2 NAND GATE	N	55	.37	55	†
MC74LVQ00DT	B LOW VOL Q2 NAND GATE	N	96	.62	96	†
MC74LVQ04D	B LOW VOL HEXINVERTER	N	55	.37	55	†
MC74LVQ04DT	B LOW VOL HEXINVERTER	N	96	.62	96	†
MC74LVQ125D	B LOW VOL QBUF TRIST OUTPT	N	55	.70	55	†
MC74LVQ125DT	B LOW VOL QBUF TRIST OUTPT	N	96	.95	96	†
MC74LVQ138D	B LOW VOLT OCTAL BUF L/DRVR	N	48	.67	48	†
MC74LVQ138DT	B LOW VOLT OCTAL BUF L/DRVR	N	96	1.00	96	†
MC74LVQ240DT	B LOW VOL BUFF/LNE DRIVER	N	75	1.25	75	†
MC74LVQ240DW	B LOW VOL BUFF/LNE DRIVER	N	38	1.00	38	†
MC74LVQ244DT	B LOW VOL OCT BUF DRIVER	N	75	1.25	75	†
MC74LVQ244DW	B LOW VOL OCT BUF DRIVER	N	38	1.00	38	†
MC74LVQ245DT	B LOW VOL OCT BID TRN IN/OT	N	75	1.28	75	†
MC74LVQ245DW	B LOW VOL OCT BID TRN IN/OT	N	38	1.03	38	†
MC74LVQ373DT	B LOW VOLT OCT BUF L/DRIVER	N	75	1.25	75	†
MC74LVQ373DW	B LOW VOLT OCT BUF L/DRIVER	N	38	1.00	38	†
MC74LVQ374DT	B LOW VOLT OCT BUF L/DRIVER	N	75	1.25	75	†
MC74LVQ374DW	B LOW VOLT OCT BUF L/DRIVER	N	38	1.00	38	†
MC74LVQ541DT	B LOW VOLT OCT BUF L/DRIVER	N	75	1.30	75	†
MC74LVQ541DW	B LOW VOLT OCT BUF L/DRIVER	N	38	1.05	38	†
MC74LVQ573DT	B LOW VOLT OCT BUF L/DRIVER	N	75	1.25	75	†
MC74LVQ573DW	B LOW VOLT OCT BUF L/DRIVER	N	38	1.00	38	†

A = OSPD/Power
 B = Analog/Logic
 J = Transportation
 L = Consumer
 N = Networking
 V = Wireless

S = Proprietary Device
 B = Motorola Blue Chip Program Device
 P = Phoenix Program
 * = First Time in Book
 † \$200 Minimum Waived

N = Key New Motorola Device
 R = Key "Focus" Motorola Device

1 = Mature, Stable, High-Volume Device
 2 = Moderate-Volume Device
 3 = Low-Volume Device

COMMERCIAL COMPONENTS

Type No.	Grp/Description	Per Unit Sugg. Factory				Type No.	Grp/Description	Per Unit Sugg. Factory					
		PC	Qty	Resale Price	Order Incrmt			PC	Qty	Resale Price	Order Incrmt		
MC74LVQ574DT	B LOWVOLT OCTAL BUF L/DRIVER	N	75	1.25	75	†	MC74LVX244DWR2	B OCTAL3-ST DRVR	N	1000	.43	1000	†
MC74LVQ574DW	B LOWVOLT OCTAL BUF L/DRIVER	N	38	1.00	38	†	MC74LVX245DT	B OCTAL3-ST	N	75	.43	75	†
MC74LVQ646DT	B LOWVOLT OCTAL BUF L/DRVR	N	62	3.25	62	†	MC74LVX245DTR2	B OCTAL3-ST	N	2500	.43	2500	†
MC74LVQ646DW	B LOWVOLT OCTAL BUF L/DRVR	N	30	3.00	30	†	MC74LVX245DW	B OCTAL3-ST	N	38	.43	38	†
MC74LVQ652DT	B LOWVOLT OCTAL BUF L/DR	N	62	3.35	62	†	MC74LVX245DWR2	B OCTAL3-ST	N	1000	.43	1000	†
MC74LVQ652DW	B LOWVOLT OCTAL BUF L/DR	N	30	3.10	30	†	MC74LVX32D	B 2-1 QUAD OR GATE	N	55	.25	55	†
MC74LVX00D	B NAND GATE	N	55	.25	55	†	MC74LVX32DT	B 2-1 QUAD OR GATE	N	96	.25	96	†
MC74LVX00DR2	B NAND GATE	N	2500	.25	2500	†	MC74LVX32DTR2	B 2-1 QUAD OR GATE	N	2500	.25	2500	†
MC74LVX00DT	B NAND GATE	N	96	.25	96	†	MC74LVX373DT	B OCT TRANSP LTCH3 ST	N	75	.43	75	†
MC74LVX00DTR2	B NAND GATE	N	2500	.25	2500	†	MC74LVX373DTR2	B OCT TRANSP LTCH3 ST	N	2500	.43	2500	†
MC74LVX02D	B NORQUAD2 INPUT	N	55	.25	55	†	MC74LVX373DW	B OCT TRANSP LTCH3 ST	N	38	.43	38	†
MC74LVX02DR2	B NORQUAD2 INPUT	N	2500	.25	2500	†	MC74LVX373DWR2	B OCT TRANSP LTCH3 ST	N	1000	.43	1000	†
MC74LVX02DT	B NORQUAD2 INPUT	N	96	.25	96	†	MC74LVX374DT	B FLIP FLOP OCT D3-ST	N	75	.43	75	†
MC74LVX02DTR2	B NORQUAD2 INPUT	N	2500	.25	2500	†	MC74LVX374DTR2	B FLIP FLOP OCT D3-ST	N	2500	.43	2500	†
MC74LVX04D	B HEX INVERTER	N	55	.25	55	†	MC74LVX374DW	B FLIP FLOP OCT D3-ST	N	38	.43	38	†
MC74LVX04DR2	B HEX INVERTER	N	2500	.25	2500	†	MC74LVX374DWR2	B FLIP FLOP OCT D3-ST	N	1000	.43	1000	†
MC74LVX04DT	B HEX INVERTER	N	96	.25	96	†	MC74LVX4245DT	B 8BIT NNV3S DUAL SUPPLY	N	62	1.01	62	†
MC74LVX04DTR2	B HEX INVERTER	N	2500	.25	2500	†	MC74LVX4245DTR2	B 8BIT NNV3S DUAL SUPPLY	N	2500	1.01	2500	†
MC74LVX08D	B QUAD2-INPUT GATE	N	55	.25	55	†	MC74LVX4245DW	B 8BIT NNV3S DUAL SUPPLY	N	30	1.01	30	†
MC74LVX08DR2	B QUAD2-INPUT GATE	N	2500	.25	2500	†	MC74LVX4245DWR2	B 8BIT NNV3S DUAL SUPPLY	N	1000	1.01	1000	†
MC74LVX08DT	B QUAD2-INPUT GATE	N	96	.25	96	†	MC74LVX573DT	B OCTL3-ST NONINVRT -D	N	75	.43	75	†
MC74LVX08DTR2	B QUAD2-INPUT GATE	N	2500	.25	2500	†	MC74LVX573DTR2	B OCTL3-ST NONINVRT -D	N	2500	.43	2500	†
MC74LVX125D	B 3ST NONINVERT BUFFER	N	55	.36	55	†	MC74LVX573DW	B OCTL3-ST NONINVRT -D	N	38	.43	38	†
MC74LVX125DR2	B 3ST NONINVERT BUFFER	N	2500	.36	2500	†	MC74LVX573DWR2	B OCTL3-ST NONINVRT -D	N	1000	.43	1000	†
MC74LVX125DT	B 3ST NONINVERT BUFFER	N	96	.36	96	†	MC74LVX74D	B FLP FLOP D TYPE DUAL	N	55	.25	55	†
MC74LVX125DTR2	B 3ST NONINVERT BUFFER	N	2500	.36	2500	†	MC74LVX74DT	B FLP FLOP D TYPE DUAL	N	96	.25	96	†
MC74LVX138D	B DECODER/DEMULTIPLX	N	48	.36	48	†	MC74LVX74DTR2	B FLP FLOP D TYPE DUAL	N	2500	.25	2500	†
MC74LVX138DR2	B DECODER/DEMULTIPLX	N	2500	.36	2500	†	MC74VHCT00AD	B QUAD2-1 NAND GATE	N	55	.25	55	†
MC74LVX138DT	B DECODER/DEMULTIPLX	N	96	.36	96	†	MC74VHCT00ADR2	B QUAD2-1 NAND GATE	N	2500	.25	2500	†
MC74LVX138DTR2	B DECODER/DEMULTIPLX	N	2500	.36	2500	†	MC74VHCT00ADT	B QUAD2-1 NAND GATE	N	96	.25	96	†
MC74LVX14D	B SCHMITT INVERTER	N	55	.25	55	†	MC74VHCT00ADTR2	B QUAD2-1 NAND GATE	N	2500	.25	2500	†
MC74LVX14DR2	B SCHMITT INVERTER	N	2500	.25	2500	†	MC74VHCT04AD	B HEX INVERTOR W/STT	N	55	.25	55	†
MC74LVX14DT	B SCHMITT INVERTER	N	96	.25	96	†	MC74VHCT04ADR2	B HEX INVERTOR W/STT	N	2500	.25	2500	†
MC74LVX14DTR2	B SCHMITT INVERTER	N	2500	.25	2500	†	MC74VHCT04ADT	B HEX INVERTOR W/STT	N	96	.25	96	†
MC74LVX157D	B DTASELECTOR/MLTIPLX2-1	N	48	.36	48	†	MC74VHCT04ADTR2	B HEX INVERTOR W/STT	N	2500	.25	2500	†
MC74LVX157DR2	B DTASELECTOR/MLTIPLX2-1	N	2500	.36	2500	†	MC74VHCT138AD	B DECODER DEMULTIPLX	N	48	.36	48	†
MC74LVX157DT	B DTASELECTOR/MLTIPLX2-1	N	96	.36	96	†	MC74VHCT138ADR2	B DECODER DEMULTIPLX	N	2500	.36	2500	†
MC74LVX157DTR2	B DTASELECTOR/MLTIPLX2-1	N	2500	.36	2500	†	MC74VHCT138ADT	B DECODER DEMULTIPLX	N	96	.36	96	†
MC74LVX240DT	B OCTAL3-ST DRVR	N	75	.43	75	†	MC74VHCT138ADTR2	B DECODER DEMULTIPLX	N	2500	.36	2500	†
MC74LVX240DTR2	B OCTAL3-ST DRVR	N	2500	.43	2500	†	MC74VHCT240ADT	B OCTAL3-ST DRVR W/STTI	N	75	.43	75	†
MC74LVX240DW	B OCTAL3-ST DRVR	N	38	.43	38	†	MC74VHCT240ADTR2	B OCTAL3-ST DRVR W/STTI	N	2500	.43	2500	†
MC74LVX240DWR2	B OCTAL3-ST DRVR	N	1000	.43	1000	†	MC74VHCT240ADW	B OCTAL3-ST DRVR W/STTI	N	38	.43	38	†
MC74LVX244DT	B OCTAL3-ST DRVR	N	75	.43	75	†	MC74VHCT240ADWR2	B OCTAL3-ST DRVR W/STTI	N	1000	.43	1000	†
MC74LVX244DTR2	B OCTAL3-ST DRVR	N	2500	.43	2500	†	MC74VHCT244ADT	B OCTAL3-ST WTH STTL	N	75	.43	75	†
MC74LVX244DW	B OCTAL3-ST DRVR	N	38	.43	38	†	MC74VHCT244ADTR2	B OCTAL3-ST WTH STTL	N	2500	.43	2500	†

A = OSPD/Power
 B = Analog/Logic
 J = Transportation
 L = Consumer
 N = Networking
 V = Wireless

S = Proprietary Device
 B = Motorola Blue Chip Program Device
 P = Phoenix Program
 * = First Time in Book
 † \$200 Minimum Waived

N = Key New Motorola Device
 R = Key "Focus" Motorola Device

1 = Mature, Stable, High-Volume Device
 2 = Moderate-Volume Device
 3 = Low-Volume Device

EFFECTIVE DATE: JANUARY 10, 1998

COMMERCIAL COMPONENTS

Type No.	Grp/Description	Per Unit Sugg. Factory				
		Resale Price	Price	Order		
PC	Qty	Price	Incrrmnt			
MC74VHCT244ADW	B OCTAL3-ST WTHSTTL	N	38	.43	38	†
MC74VHCT244ADWR2	B OCTAL3-ST WTHSTTL	N	1000	.43	1000	†
MC74VHCT245ADT	B OCTAL3-ST WTHSTTL	N	75	.43	75	†
MC74VHCT245ADTR2	B OCTAL3-ST WTHSTTL	N	2500	.43	2500	†
MC74VHCT245ADW	B OCTAL3-ST WTHSTTL	N	38	.43	38	†
MC74VHCT245ADWR2	B OCTAL3-ST WTHSTTL	N	1000	.43	1000	†
MC74VHCT373ADT	B OCT TRANSPLTCH3-ST	N	75	.43	75	†
MC74VHCT373ADTR2	B OCT TRANSPLTCH3-ST	N	2500	.43	2500	†
MC74VHCT373ADW	B OCT TRANSPLTCH3-ST	N	38	.43	38	†
MC74VHCT373ADWR2	B OCT TRANSPLTCH3-ST	N	1000	.43	1000	†
MC74VHCT541ADT	B OT3-ST NVRT/BF	N	75	.43	75	†
MC74VHCT541ADTR2	B OT3-ST NVRT/BF	N	2500	.43	2500	†
MC74VHCT541ADW	B OT3-ST NVRT/BF	N	38	.43	38	†
MC74VHCT541ADWR2	B OT3-ST NVRT/BF	N	1000	.43	1000	†
MC74VHCT573ADT	B OCTL3-STNONINVRT-D-TYP	N	75	.43	75	†
MC74VHCT573ADTR2	B OCTL3-STNONINVRT-D-TYP	N	2500	.43	2500	†
MC74VHCT573ADW	B OCTL3-STNONINVRT-D-TYP	N	38	.43	38	†
MC74VHCT573ADWR2	B OCTL3-STNONINVRT-D-TYP	N	1000	.43	1000	†
MC74VHCT574ADT	B OCTL3-STN-INVRT D	N	75	.43	75	†
MC74VHCT574ADTR2	B OCTL3-STN-INVRT D	N	2500	.43	2500	†
MC74VHCT574ADW	B OCTL3-STN-INVRT D	N	38	.43	38	†
MC74VHCT574ADWR2	B OCTL3-STN-INVRT D	N	1000	.43	1000	†
MC74VHC00D	B NANDGATE	N	55	.25	55	†
MC74VHC00DR2	B NANDGATE	N	2500	.25	2500	†
MC74VHC00DT	B NANDGATE	N	96	.25	96	†
MC74VHC00DTR2	B NANDGATE	N	2500	.25	2500	†
MC74VHC125D	B 3STNONINVERT BUF	N	55	.36	55	†
MC74VHC125DR2	B 3STNONINVERT BUF	N	2500	.36	2500	†
MC74VHC125DT	B 3STNONINVERT BUF	N	96	.36	96	†
MC74VHC125DTR2	B 3STNONINVERT BUF	N	2500	.36	2500	†
MC74VHC126D	B QUAD3STNONINVERT	N	55	.36	55	†
MC74VHC126DR2	B QUAD3STNONINVERT	N	2500	.36	2500	†
MC74VHC126DT	B QUAD3STNONINVERT	N	96	.36	96	†
MC74VHC126DTR2	B QUAD3STNONINVERT	N	2500	.36	2500	†
MC74VHC132D	B QD2-INPT NANDGATE	N	55	.40	55	†
MC74VHC132DR2	B QD2-INPT NANDGATE	N	2500	.40	2500	†
MC74VHC132DT	B QD2-INPT NANDGATE	N	96	.40	96	†
MC74VHC132DTR2	B QD2-INPT NANDGATE	N	2500	.40	2500	†
MC74VHC138D	B DECODER/DEMULTIPLX	N	48	.36	48	†
MC74VHC138DR2	B DECODER/DEMULTIPLX	N	2500	.36	2500	†
MC74VHC138DT	B DECODER/DEMULTIPLX	N	96	.36	96	†
MC74VHC138DTR2	B DECODER/DEMULTIPLX	N	2500	.36	2500	†
MC74VHC139D	B DECODER10F4DUAL	N	55	.36	48	†
MC74VHC139DR2	B DECODER10F4DUAL	N	2500	.36	2500	†
MC74VHC139DT	B DECODER10F4DUAL	N	96	.36	96	†

Type No.	Grp/Description	Per Unit Sugg. Factory				
		Resale Price	Price	Order		
PC	Qty	Price	Incrrmnt			
MC74VHC139DTR2	B DECODER10F4DUAL	N	2500	.36	2500	†
MC74VHC14D	B SCHMITT INVERTER	N	55	.25	55	†
MC74VHC14DR2	B SCHMITT INVERTER	N	2500	.25	2500	†
MC74VHC14DT	B SCHMITT INVERTER	N	96	.25	96	†
MC74VHC14DTR2	B SCHMITT INVERTER	N	2500	.25	2500	†
MC74VHC157D	B DTASELCTOR/MLTIPLX2-I	N	48	.36	48	†
MC74VHC157DR2	B DTASELCTOR/MLTIPLX2-I	N	2500	.36	2500	†
MC74VHC157DT	B DTASELCTOR/MLTIPLX2-I	N	96	.36	96	†
MC74VHC157DTR2	B DTASELCTOR/MLTIPLX2-I	N	2500	.36	2500	†
MC74VHC240DT	B OCTAL3-ST DRVR	N	25	.43	500	†
MC74VHC240DTR2	B OCTAL3-ST DRVR	N	2500	.43	2500	†
MC74VHC240DW	B OCTAL3-ST DRVR	N	38	.43	38	†
MC74VHC240DWR2	B OCTAL3-ST DRVR	N	1000	.43	1000	†
MC74VHC244DT	B OCTAL3ST DRVR	N	75	.43	75	†
MC74VHC244DTR2	B OCTAL3ST DRVR	N	2500	.43	2500	†
MC74VHC244DW	B OCTAL3-ST DRVR	N	38	.43	38	†
MC74VHC244DWR2	B OCTAL3-ST DRVR	N	1000	.43	1000	†
MC74VHC245DT	B OCTAL3-ST	N	75	.43	75	†
MC74VHC245DTR2	B OCTAL3-ST	N	2500	.43	2500	†
MC74VHC245DW	B OCTAL3-ST	N	38	.43	38	†
MC74VHC245DWR2	B OCTAL3-ST	N	1000	.43	1000	†
MC74VHC32D	B 2-1QUAD ORGATE	N	55	.25	55	†
MC74VHC32DR2	B 2-1QUAD ORGATE	N	2500	.25	2500	†
MC74VHC32DT	B 2-1QUAD ORGATE	N	96	.25	96	†
MC74VHC32DTR2	B 2-1QUAD ORGATE	N	2500	.25	2500	†
MC74VHC373DT	B OCT TRANSPLTCH3-ST	N	75	.43	75	†
MC74VHC373DTR2	B OCT TRANSPLTCH3-ST	N	2500	.43	2500	†
MC74VHC373DW	B OCT TRANSPLTCH3-ST	N	38	.43	38	†
MC74VHC373DWR2	B OCT TRANSPLTCH3-ST	N	1000	.43	1000	†
MC74VHC374DT	B FLIP FLOP OCT D3-ST	N	75	.43	75	†
MC74VHC374DTR2	B FLIP FLOP OCT D3-ST	N	2500	.43	2500	†
MC74VHC374DW	B FLIP FLOP OCT D3-ST	N	38	.43	38	†
MC74VHC374DWR2	B FLIP FLOP OCT D3-ST	N	1000	.43	1000	†
MC74VHC393D	B DUAL BIN RIPPLE CNTR	N	25	.43	500	†
MC74VHC393DR2	B DUAL BIN RIPPLE CNTR	N	1000	.43	1000	†
MC74VHC393DT	B DUAL BIN RIPPLE CNTR	N	75	.43	75	†
MC74VHC393DTR2	B DUAL BIN RIPPLE CNTR	N	2500	.43	2500	†
MC74VHC540DT	B OT3-ST NVRT/BFL/DR/L/RC	N	75	.43	75	†
MC74VHC540DTR2	B OT3-ST NVRT/BFL/DR/L/RC	N	2500	.43	2500	†
MC74VHC540DW	B OT3-ST NVRT/BFL/DR/L/RC	N	38	.43	38	†
MC74VHC540DWR2	B OT3-ST NVRT/BFL/DR/L/RC	N	1000	.43	1000	†
MC74VHC541DT	B OT3-ST NVRT/BFL/DR/L/R	N	75	.43	75	†
MC74VHC541DTR2	B OT3-ST NVRT/BFL/DR/L/R	N	2500	.43	2500	†
MC74VHC541DW	B OT3-ST NVRT/BFL/DR/L/R	N	38	.43	38	†
MC74VHC541DWR2	B OT3-ST NVRT/BFL/DR/L/R	N	1000	.43	1000	†

A = OSPD/Power
 B = Analog/Logic
 J = Transportation
 L = Consumer
 N = Networking
 V = Wireless

S = Proprietary Device
 B = Motorola Blue Chip Program Device
 P = Phoenix Program
 * = First Time in Book
 † = \$200 Minimum Waived

N = Key New Motorola Device
 R = Key "Focus" Motorola Device

1 = Mature, Stable, High-Volume Device
 2 = Moderate-Volume Device
 3 = Low-Volume Device

COMMERCIAL COMPONENTS

Type No.	Grp/Description	PC	Unit Qty	Sugg. Resale Price	Factory Order Incrmt
MC74VHC573DT	B OCT3STNONINVRT DTYPE	N	75	.43	75 †
MC74VHC573DTR2	B OCT3STNONINVRT DTYPE	N	2500	.43	2500 †
MC74VHC573DW	B OCT3STNONINVRT DTYPE	N	38	.43	38 †
MC74VHC573DWR2	B OCT3STNONINVRT DTYPE	N	1000	.43	1000 †
MC74VHC574DT	B OCTL3-STN-INVRTDFL/FL	N	75	.43	75 †
MC74VHC574DTR2	B OCTL3-STN-INVRTDFL/FL	N	2500	.43	2500 †
MC74VHC574DW	B OCTL3-STN-INVRTDFL/FL	N	38	.43	38 †
MC74VHC574DWR2	B OCTL3-STN-INVRTDFL/FL	N	1000	.43	1000 †
MC74VHC595D	B SHIFT REG.3STATE	N	25	1.35	500 †
MC74VHC595DR2	B SHIFT REG.3STATE	N	2500	1.35	2500 †
MC74VHC595DT	B SHIFT REG.3STATE	N	96	1.35	96 †
MC74VHC595DTR2	B SHIFT REG.3STATE	N	2500	1.35	2500 †
MC74VHC74D	B FFDTYPE DUAL	N	55	.25	55 †
MC74VHC74DR2	B FFDTYPE DUAL	N	2500	.25	2500 †
MC74VHC74DT	B FFDTYPE DUAL	N	96	.25	96 †
MC74VHC74DTR2	B FFDTYPE DUAL	N	2500	.25	2500 †
MC75172BDW	B RS-485 QD DIFF LINE DRVR	2	38	2.08	38 †
MC75172BDWR2	B RS-485 QD DIFF LINE DRVR	N	1000	2.08	1000 ★ †
MC75174BDW	B RS-485 QD DIFF LINE DRVR	2	38	1.81	38 †
MC75174BDWR2	B RS-485 QD DIFF LINE DRVR	2	1000	1.81	1000 †
MC75174BP	B RS-485 QD DIFF LINE DRVR	2	25	1.74	500 †
MC78BC30NTR	B LOPWR VOLTAGE REGULATOR	2	3000	.37	3000 †
MC78BC33NTR	B LOPWR VOLTAGE REGULATOR	2	3000	.37	3000 †
MC78BC40NTR	B LOPWR VOLTAGE REGULATOR	2	3000	.37	3000 †
MC78BC50NTR	B LOPWR VOLTAGE REGULATOR	2	3000	.37	3000 †
MC78FC30HT1	B LOPWR VOLTAGE REGULATOR	2	1000	.39	1000 †
MC78FC33HT1	B LOPWR VOLTAGE REGULATOR	2	1000	.39	1000 †
MC78FC40HT1	B LOPWR VOLTAGE REGULATOR	2	1000	.39	1000 †
MC78FC50HT1	B LOPWR VOLTAGE REGULATOR	2	1000	.39	1000 †
MC78LC30HT1	B LOPWR VOLTAGE REGULATOR	2	1000	.34	1000 †
MC78LC30NTR	B LOPWR VOLTAGE REGULATOR	2	3000	.30	3000 †
MC78LC33HT1	B LOPWR VOLTAGE REGULATOR	2	1000	.34	1000 †
MC78LC33NTR	B LOPWR VOLTAGE REGULATOR	2	3000	.30	3000 †
MC78LC40HT1	B LOPWR VOLTAGE REGULATOR	2	1000	.34	1000 †
MC78LC40NTR	B LOPWR VOLTAGE REGULATOR	2	3000	.30	3000 †
MC78LC50HT1	B LOPWR VOLTAGE REGULATOR	2	1000	.34	1000 †
MC78LC50NTR	B LOPWR VOLTAGE REGULATOR	2	3000	.30	3000 †
MC78L05ABD	B FIXED VOLTAGE REG	2	98	.44	98 †
MC78L05ABDR2	B FIXED VOLT REG	2	2500	.46	2500 †
MC78L05ABP	B FIXED VOLTAGE REG	2	2000	.44	2000 †
MC78L05ABPRA	B FIXED VOLTAGE REG	2	2000	.46	2000 †
MC78L05ACD	B LIN LOW CURR POS5V REG	1	98	.36	98 †
MC78L05ACDR2	B LIN LO-CUR POS5V REG T/R	1	2500	.39	2500 †
MC78L05ACP	B LIN LOW CURR POS5V REG	1	2000	.36	2000 †
MC78L08ABD	B FIXED VOLTAGE REG	2	98	.44	98 †

Type No.	Grp/Description	PC	Unit Qty	Sugg. Resale Price	Factory Order Incrmt
MC78L08ABDR2	B FIXED VOLT REG	2	2500	.46	2500 †
MC78L08ABP	B FIXED VOLTAGE REG	2	2000	.44	2000 †
MC78L08ABPRA	B FIXED VOLTAGE REGULATOR	N	2000	.46	2000 †
MC78L08ACD	B LIN LOW CURR POS8V REG	2	98	.36	98 †
MC78L08ACDR2	B LIN LO-CUR POS8V REG T/R	2	2500	.39	2500 †
MC78L08ACP	B LIN LOW CURR POS8V REG	1	2000	.36	2000 †
MC78L09ABD	B LIN LOW CURR POS9V REG	N	98	.44	98 †
MC78L09ACD	B LIN LOW CURR POS9V REG	2	98	.36	98 †
MC78L09ACDR2	B LIN LO CUR POS9V REG T/R	2	2500	.39	2500 †
MC78L09ACP	B LIN LOW CURR POS9V REG	2	2000	.36	2000 †
MC78L12ABD	B FIXED VOLTAGE REG	2	98	.44	98 †
MC78L12ABDR2	B FIXED VOLT REG	2	2500	.46	2500 †
MC78L12ABP	B FIXED VOLTAGE REG	2	2000	.44	2000 †
MC78L12ABPRA	B FIXED VOLTAGE REG	2	2000	.46	2000 †
MC78L12ABPRE	B FIXED VOLTAGE REG	N	2000	.69	2000 †
MC78L12ACD	B LIN LOW CURR POS12V REG	2	98	.36	98 †
MC78L12ACDR2	B LIN LO-CUR POS12V RG T/R	2	2500	.39	2500 †
MC78L12ACP	B LIN LOW CURR POS12V REG	1	2000	.36	2000 †
MC78L15ABD	B FIXED VOLTAGE REG	2	98	.44	98 †
MC78L15ABDR2	B FIXED VOLT REG	2	2500	.46	2500 †
MC78L15ABP	B FIXED VOLTAGE REG	2	2000	.44	2000 †
MC78L15ABPRA	B FIXED VOLTAGE REG	2	2000	.46	2000 †
MC78L15ACD	B LIN LOW CURR POS15V REG	N	98	.36	98 †
MC78L15ACDR2	B LIN LO-CUR POS15V RG T/R	2	2500	.39	2500 †
MC78L15ACP	B LIN LOW CURR POS15V REG	1	2000	.36	2000 †
MC78L18ABP	B FIXED VOLTAGE REG	2	2000	.65	2000 †
MC78L18ACP	B LIN LOW CURR POS18V REG	2	2000	.36	2000 †
MC78L24ABP	B FIXED VOLTAGE REG	2	2000	.44	2000 †
MC78L24ABPRA	B FIXED VOLTAGE REG	2	2000	.69	2000 †
MC78L24ACP	B LIN LOW CURR POS24V REG	2	2000	.36	2000 †
MC78M05ACDT	B MEDIUM POWER VOLT REG	2	75	1.14	75 †
MC78M05ACDTRK	B MEDIUM POWER VOLT REG	N	2500	1.18	2500 †
MC78M05BDT	B 3T1/2A POS REG	N	75	1.20	75 †
MC78M05BDT-001	B MED CURRENT POS5V REG	N	75	1.20	75 †
MC78M05BDTRK	B DPAK POS VOLTAGE REG	N	2500	1.25	2500 †
MC78M05BT	B LIN MED CURR POS5V REG	2	50	.59	50 †
MC78M05CDT	B LIN MED CUR POS5V REG	1	75	.82	75 †
MC78M05CDT-001	B LIN MED CUR POS5V REG	N	75	.82	75 †
MC78M05CDTRK	B POS VOLTAGE REG	1	2500	1.05	2500 †
MC78M05CT	B LIN MED CURR POS5V REG	1	50	.46	50 †
MC78M06BT	B LIN MED CURR POS6V REG	2	50	.59	50 †
MC78M06CDT	B POS VOLT REG	2	75	.82	75 †
MC78M06CDTRK	B POS VOLT REG	N	2500	.86	2500 †
MC78M06CT	B LIN MED CURR POS6V REG	2	50	.46	50 †
MC78M08BDT	B 3T1/2A POS REG	2	75	1.20	75 †

A = OSPD/Power
 B = Analog/Logic
 J = Transportation
 L = Consumer
 N = Networking
 V = Wireless

S = Proprietary Device
 B = Motorola Blue Chip Program Device
 P = Phoenix Program
 ★ = First Time in Book
 † \$200 Minimum Waived

N = Key New Motorola Device
 R = Key "Focus" Motorola Device

1 = Mature, Stable, High-Volume Device
 2 = Moderate-Volume Device
 3 = Low-Volume Device

COMMERCIAL COMPONENTS

Type No.	Grp/Description	Per Unit Sugg. Factory				
		Resale Price	Price	Order		
PC	Qty	Price	Incrmnt			
MC78M08BDTRK	B DPAK POS VOLTAGE REG	N	2500	1.25	2500	†
MC78M08BT	B LIN MED CURR POS8V REG	2	50	.59	50	†
MC78M08CDT	B LIN MED CURR POS8V REG	1	75	.82	75	†
MC78M08CDT-001	B LIN MED CURR POS8V REG	3	75	1.88	75	†
MC78M08CDTRK	B POS VOLTAGE REG	N	2500	1.05	2500	†
MC78M08CT	B LIN MED CURR POS8V REG	1	50	.46	50	†
MC78M09BDT	B 9V POSITIVE VOLTAGE REG	N	75	1.20	75	†
MC78M09BT	B 9V POSITIVE VOLTAGE REG	N	50	.88	50	†
MC78M09CDT	B 9V POSITIVE VOLTAGE REG	2	75	1.01	75	†
MC78M09CDTRK	B 9V POSITIVE VOLTAGE REG	N	2500	1.05	2500	†
MC78M09CT	B 9V POSITIVE VOLTAGE REG	2	50	.69	50	†
MC78M12BDT	B 3T1/2A POS REG	2	75	1.20	75	†
MC78M12BDTRK	B DPAK POS VOLTAGE REG	N	2500	1.25	2500	†
MC78M12BT	B LIN MED CURR POS12V REG	2	50	.59	50	†
MC78M12CDT	B LIN MED CURR POS12V REG	1	75	.82	75	†
MC78M12CDT-001	B LIN MED CURR POS12V REG	3	75	1.88	75	†
MC78M12CDTRK	B POS VOLTAGE REG	2	2500	1.05	2500	†
MC78M12CT	B LIN MED CURR POS12V REG	1	50	.69	50	†
MC78M15BDT	B 3T1/2A POS REG	2	75	1.20	75	†
MC78M15BDTRK	B DPAK POS VOLTAGE REG	N	2500	1.25	2500	†
MC78M15BT	B LIN MED CURR POS15V REG	2	50	.88	50	†
MC78M15CDT	B LIN MED CURR POS15V REG	2	75	.82	75	†
MC78M15CDT-001	B LIN MED CURR POS15V REG	N	75	.82	75	†
MC78M15CDTRK	B POS VOLTAGE REG	N	2500	1.05	2500	†
MC78M15CT	B LIN MED CURR POS15V REG	2	50	.46	50	†
MC78M18BT	B LIN MED CURR POS18V REG	3	50	1.64	50	†
MC78M18CT	B LIN MED CURR POS18V REG	N	50	.46	50	†
MC78M20BT	B LIN MED CURR POS20V REG	3	50	1.64	50	†
MC78M20CT	B LIN MED CURR POS20V REG	2	50	.46	50	†
MC78M24BT	B LIN MED CURR POS24V REG	2	50	.59	50	†
MC78M24CT	B LIN MED CURR POS24V REG	2	50	.46	50	†
MC78T05ABT	B LIN3-AMP POS5V REG	2	50	2.33	50	†
MC78T05ACT	B LIN3-AMP POS5V REG	1	50	1.97	50	†
MC78T05BT	B LIN3-AMP POS5V REG	2	50	2.10	50	†
MC78T05CT	B LIN3-AMP POS5V REG	1	50	1.77	50	†
MC78T08CT	B LIN3-AMP POS8V REG	2	50	1.77	50	†
MC78T12ACT	B LIN3-AMP POS12V REG	2	50	1.97	50	†
MC78T12BT	B LIN VOLTAGE REGULATOR	2	50	2.10	50	†
MC78T12CT	B LIN3-AMP POS12V REG	2	50	1.77	50	†
MC78T15ABT	B LIN3-AMP POS15V REG	2	50	2.33	50	†
MC78T15ACT	B LIN3-AMP POS15V REG	N	50	2.92	50	†
MC78T15CT	B LIN3-AMP POS15V REG	2	50	1.77	50	†
MC7805.2CT	B LIN3-TERM POS5V REG	2	50	.55	50	†
MC7805ACD2T	B 5V2% SURFACE MT	N	50	1.05	500	†
MC7805ACD2TR4	B 5V2% SURFACE MT	N	800	1.03	800	†

Type No.	Grp/Description	Per Unit Sugg. Factory				
		Resale Price	Price	Order		
PC	Qty	Price	Incrmnt			
MC7805ACT	B LIN3-TERM POS5V REG	1	50	.64	50	†
MC7805BD2T	B POS1.5A3-TERM VOLT REG	N	50	1.14	500	†
MC7805BD2TR4	B POS1.5A3-TERM VOLT REG	N	800	1.08	800	†
MC7805BT	B LIN3-TERM POS5V REG	1	50	.67	50	†
MC7805CD2T	B POS1.5A3-TERM VOLT REG	N	50	.95	500	†
MC7805CD2TR4	B POS1.5A3-TERM VOLT REG	2	800	.99	800	†
MC7805CT	B LIN3-TERM POS5V REG	1	50	.55	50	†
MC7806ACT	B LIN3-TERM POS6V REG	N	50	.64	50	†
MC7806BD2T	B POS1.5A3-TERM VOLT REG	N	50	1.14	500	†
MC7806BD2TR4	B POS1.5A3-TERM VOLT REG	N	800	1.08	800	†
MC7806BT	B LIN3-TERM POS6V REG	N	50	.67	50	†
MC7806CD2T	B POS1.5A3-TERM VOLT REG	N	50	.95	500	†
MC7806CD2TR4	B POS1.5A3-TERM VOLT REG	2	800	.99	800	†
MC7806CT	B LIN3-TERM POS6V REG	2	50	.55	50	†
MC7808ABT	B POS.8VOLT REGULATOR	N	50	.75	50	★
MC7808ACT	B LIN3-TERM POS8V REG	N	50	.64	50	†
MC7808BD2T	B POS1.5A3-TERM VOLT REG	N	50	1.14	500	†
MC7808BD2TR4	B POS1.5A3-TERM VOLT REG	N	800	1.08	800	†
MC7808BT	B LIN3-TERM POS8V REG	2	50	.67	50	†
MC7808CD2T	B POS1.5A3-TERM VOLT REG	N	50	.95	500	†
MC7808CD2TR4	B POS1.5A3-TERM VOLT REG	2	800	.99	800	†
MC7808CT	B LIN3-TERM POS8V REG	1	50	.55	50	†
MC7809ACT	B LIN3-TERM POS9V REG	N	50	.64	50	†
MC7809BD2T	B POS1.5A3-TERM VOLT REG	N	50	1.14	500	†
MC7809BD2TR4	B POS1.5A3-TERM VOLT REG	N	800	1.08	800	†
MC7809CD2T	B POS1.5A3-TERM VOLT REG	N	50	.95	500	†
MC7809CD2TR4	B POS1.5A3-TERM VOLT REG	2	800	.99	800	†
MC7809CT	B LIN3-TERM POS9V REG	2	50	.55	50	†
MC7812ACD2T	B 5V2% SURFACE MT	N	50	1.05	500	†
MC7812ACD2TR4	B 5V2% SURFACE MT	N	800	1.03	800	†
MC7812ACT	B LIN3-TERM POS12V REG	1	50	.64	50	†
MC7812BD2T	B POS1.5A3-TERM VOLT REG	N	50	1.14	500	†
MC7812BD2TR4	B POS1.5A3-TERM VOLT REG	N	800	1.08	800	†
MC7812BT	B LIN3-TERM POS12V REG	2	50	.67	50	†
MC7812CD2T	B POS1.5A3-TERM VOLT REG	N	50	.95	500	†
MC7812CD2TR4	B POS1.5A3-TERM VOLT REG	2	800	.99	800	†
MC7812CT	B LIN3-TERM POS12V REG	1	50	.55	50	†
MC7815ACD2T	B 5V2% SURFACE MT	N	50	1.05	500	†
MC7815ACD2TR4	B 5V2% SURFACE MT	N	800	1.03	800	†
MC7815ACT	B LIN3-TERM POS15V REG	2	50	.64	50	†
MC7815BD2T	B POS1.5A3-TERM VOLT REG	N	50	1.14	500	†
MC7815BD2TR4	B POS1.5A3-TERM VOLT REG	N	800	1.08	800	†
MC7815BT	B LIN3-TERM POS15V REG	2	50	.67	50	†
MC7815CD2T	B POS1.5A3-TERM VOLT REG	N	50	.95	500	†
MC7815CD2TR4	B POS1.5A3-TERM VOLT REG	2	800	.99	800	†

A = OSPD/Power
 B = Analog/Logic
 J = Transportation
 L = Consumer
 N = Networking
 V = Wireless

S = Proprietary Device
 B = Motorola Blue Chip Program Device
 P = Phoenix Program
 ★ = First Time in Book
 † \$200 Minimum Waived

N = Key New Motorola Device
 R = Key "Focus" Motorola Device

1 = Mature, Stable, High-Volume Device
 2 = Moderate-Volume Device
 3 = Low-Volume Device

COMMERCIAL COMPONENTS

Type No.	Grp/Description	Per Unit Sugg. Factory					Type No.	Grp/Description	Per Unit Sugg. Factory				
		PC	Qty	Resale Price	Order Price				PC	Qty	Resale Price	Order Price	
MC7815CT	B LIN3-TERMPOS15VREG	1	50	.55	50	†	MC79M05BT	B 3T1/2A.NEGREG	2	50	.59	50	†
MC7818ACT	B LIN3-TERMPOS18VREG	3	50	1.92	50	†	MC79M05CDT	B LINMEDCURNEG5VREG	1	75	.82	75	†
MC7818BD2T	B POS1.5A3-TERMVOLTREG	N	50	1.14	500	†	MC79M05CDT-001	B LINMEDCURNEG5VREG	N	75	.82	75	†
MC7818BD2TR4	B POS1.5A3-TERMVOLTREG	N	800	1.08	800	†	MC79M05CDTRK	B NEG VOLTAGE REG	N	2500	.71	2500	†
MC7818BT	B LIN3-TERMPOS18VREG	3	50	2.17	50	†	MC79M05CT	B LINMEDCURRNEG5VREG	2	50	.46	50	†
MC7818CD2T	B POS1.5A3-TERMVOLTREG	N	50	.95	500	†	MC79M08BDT	B 3-TERMNEG VOLT REG	N	75	1.20	75	†
MC7818CD2TR4	B POS1.5A3-TERMVOLTREG	2	800	.99	800	†	MC79M08CDT	B 3-TERMNEG VOLT REG	N	75	.82	75	†
MC7818CT	B LIN3-TERMPOS18VREG	2	50	.55	50	†	MC79M08CT	B 3-TERMNEG VOLT REG	N	50	.46	50	†
MC7824ACT	B LIN3-TERMPOS24VREG	N	50	.64	50	†	MC79M12BDT	B 3T1/2A.NEGREG	2	75	1.20	75	†
MC7824BD2T	B POS1.5A3-TERMVOLTREG	N	50	1.14	500	†	MC79M12BDT-001	B 3T1/2A.NEGREG	N	75	1.20	75	†
MC7824BD2TR4	B POS1.5A3-TERMVOLTREG	N	800	1.08	800	†	MC79M12BDTRK	B NEG VOLT REG	N	2500	1.25	2500	†
MC7824BT	B LIN3-TERMPOS24VREG	2	50	.99	50	†	MC79M12BT	B 3T1/2A.NEGREG	2	50	.59	50	†
MC7824CD2T	B POS1.5A3-TERMVOLTREG	N	50	.95	500	†	MC79M12CDT	B LINMEDCURNEG12VREG	2	75	.82	75	†
MC7824CD2TR4	B POS1.5A3-TERMVOLTREG	2	800	.99	800	†	MC79M12CDT-001	B LINMEDCURNEG12VREG	3	75	1.96	75	†
MC7824CT	B LIN3-TERMPOS24VREG	1	50	.82	50	†	MC79M12CDTRK	B NEG VOLTAGE REG	N	2500	1.05	2500	†
MC79L05ABD	B FIXEDVOLTAGE REG	2	98	.44	98	†	MC79M12CT	B LINMEDCURRNEG12VREG	2	50	.46	50	†
MC79L05ABDR2	B 3TERMNEG VOLT REG	2	2500	.46	2500	†	MC79M15BDT	B 3T1/2A.NEGREG	N	75	1.20	75	†
MC79L05ABP	B FIXEDVOLTAGE REG	2	2000	.44	2000	†	MC79M15BDT-001	B 3T1/2A.NEGREG	N	75	1.20	75	†
MC79L05ABPRA	B FIXEDVOLTAGE REG	2	2000	.46	2000	†	MC79M15BDTRK	B NEG VOLT REG	N	2500	1.25	2500	†
MC79L05ACD	B LINLOWCURRNEG5VREG	1	98	.36	98	†	MC79M15BT	B 3T1/2A.NEGREG	2	50	.59	50	†
MC79L05ACDR2	B LINLO-CURNEG5VREG T/R	2	2500	.39	2500	†	MC79M15CDT	B LINMEDCURNEG15VREG	2	75	.82	75	†
MC79L05ACP	B LINLOWCURRNEG5VREG	1	2000	.36	2000	†	MC79M15CDT-001	B LINMEDCURNEG15VREG	3	75	1.88	75	†
MC79L12ABD	B FIXEDVOLTAGE REG	2	98	.44	98	†	MC79M15CDTRK	B NEG VOLTAGE REG	N	2500	1.05	2500	†
MC79L12ABDR2	B 3TERMNEG VOLT REG	2	2500	.69	2500	†	MC79M15CT	B LINMEDCURRNEG15VREG	2	50	.46	50	†
MC79L12ABP	B FIXEDVOLTAGE REG	2	2000	.44	2000	†	MC7905.2CT	B LIN3-TERMNEG5.2VREG	2	50	.55	50	†
MC79L12ABPRA	B FIXEDVOLTAGE REG	2	2000	.46	2000	†	MC7905ACD2T	B D2PAK NEG VOLT REG	N	50	1.05	500	†
MC79L12ACD	B LINLOWCURRNEG12VREG	2	98	.36	98	†	MC7905ACD2TR4	B D2PAK NEG VOLT REG	N	800	1.03	800	†
MC79L12ACDR2	B LINLO-CURNEG12V RGT/R	2	2500	.58	2500	†	MC7905ACT	B LIN3-TERMNEG5VREG	2	50	.64	50	†
MC79L12ACP	B LINLOWCURRNEG12VREG	1	2000	.36	2000	†	MC7905BD2T	B D2PAK NEG VOLT REG	N	50	1.14	500	†
MC79L15ABD	B FIXEDVOLTAGE REG	2	98	.44	98	†	MC7905BD2TR4	B D2PAK NEG VOLT REG	N	800	1.08	800	†
MC79L15ABDR2	B 3TERMNEG VOLT REG	2	2500	.69	2500	†	MC7905BT	B LIN NEG SPOT VOLT REG	2	50	.67	50	†
MC79L15ABP	B FIXEDVOLTAGE REG	2	2000	.44	2000	†	MC7905CD2T	B D2PAK NEG VOLT REG	N	50	.95	500	†
MC79L15ABPRA	B FIXEDVOLTAGE REG	2	2000	.46	2000	†	MC7905CD2TR4	B D2PAK NEG VOLT REG	N	800	.99	800	†
MC79L15ACD	B LINLOWCURRNEG15VREG	N	98	.36	98	†	MC7905CT	B LIN3-TERMNEG5VREG	1	50	.55	50	†
MC79L15ACDR2	B LINLO-CURNEG15V RGT/R	2	2500	.39	2500	†	MC7906CD2T	B D2PAK NEG VOLT REG	N	50	.95	500	†
MC79L15ACP	B LINLOWCURRNEG15VREG	2	2000	.36	2000	†	MC7906CD2TR4	B D2PAK NEG VOLT REG	N	800	.99	800	†
MC79L18ABP	B FIXEDVOLTAGE REG	2	2000	.44	2000	†	MC7906CT	B LIN3-TERMNEG6VREG	2	50	.55	50	†
MC79L18ABPRA	B FIXEDVOLTAGE REG	2	2000	.46	2000	†	MC7908ACT	B NEGATIVE VOLT REG	N	50	.64	50	†
MC79L18ACP	B LINLOWCURRNEG18VREG	N	2000	.36	2000	†	MC7908CD2T	B D2PAK NEG VOLT REG	N	50	.95	500	†
MC79L24ABP	B FIXEDVOLTAGE REG	2	2000	.44	2000	†	MC7908CD2TR4	B D2PAK NEG VOLT REG	N	800	.99	800	†
MC79L24ABPRA	B FIXEDVOLTAGE REG	2	2000	.46	2000	†	MC7908CT	B LIN3-TERMNEG8VREG	1	50	.55	50	†
MC79L24ACP	B LINLOWCURRNEG24VREG	3	2000	1.00	2000	†	MC7912ACD2T	B D2PAK NEG VOLT REG	N	50	1.05	500	†
MC79M05BDT	B 3T1/2A.NEGREG	2	75	1.20	75	†	MC7912ACD2TR4	B D2PAK NEG VOLT REG	N	800	1.03	800	†
MC79M05BDT-001	B 3T1/2A.NEGREG	N	75	1.20	75	†	MC7912ACT	B LIN3-TERMNEG12VREG	2	50	.64	50	†
MC79M05BDTRK	B NEG VOLT REG	N	2500	1.25	2500	†	MC7912BD2T	B D2PAK NEG VOLT REG	N	50	1.14	500	†

A = OSPD/Power
 B = Analog/Logic
 J = Transportation
 L = Consumer
 N = Networking
 V = Wireless

S = Proprietary Device
 B = Motorola Blue Chip Program Device
 P = Phoenix Program
 * = First Time in Book
 † \$200 Minimum Waived

N = Key New Motorola Device
 R = Key "Focus" Motorola Device

1 = Mature, Stable, High-Volume Device
 2 = Moderate-Volume Device
 3 = Low-Volume Device

EFFECTIVE DATE: JANUARY 10, 1998

COMMERCIAL COMPONENTS

Type No.	Grp/Description	Per Unit Sugg. Factory				
		Resale Price	Price	Order Incrmt		
PC	Qty					
MC7912BD2TR4	B D2PAK NEG VOLT REG	N	800	1.08	800	†
MC7912BT	B LIN NEG SPOT VOLT REG	2	50	.67	50	†
MC7912CD2T	B D2PAK NEG VOLT REG	N	50	.95	500	†
MC7912CD2TR4	B D2PAK NEG VOLT REG	N	800	.99	800	†
MC7912CT	B LIN3-TERM NEG12V REG	1	50	.55	50	†
MC7915ACD2T	B D2PAK NEG VOLT REG	N	50	1.05	500	†
MC7915ACD2TR4	B D2PAK NEG VOLT REG	N	800	1.03	800	†
MC7915ACT	B LIN3-TERM NEG15V REG	2	50	.64	50	†
MC7915BD2T	B D2PAK NEG VOLT REG	N	50	1.14	500	†
MC7915BD2TR4	B D2PAK NEG VOLT REG	N	800	1.08	800	†
MC7915BT	B LIN NEG SPOT VOLT REG	2	50	.67	50	†
MC7915CD2T	B D2PAK NEG VOLT REG	N	50	.95	500	†
MC7915CT	B LIN3-TERM NEG15V REG	1	50	.55	50	†
MC7918CD2T	B D2PAK NEG VOLT REG	N	50	.95	500	†
MC7918CT	B LIN3-TERM NEG18V REG	2	50	.55	50	†
MC7924BD2T	B D2PAK NEG VOLT REG	N	50	1.14	500	†
MC7924BD2TR4	B D2PAK NEG VOLT REG	N	800	1.08	800	†
MC7924BT	B LIN NEG SPOT VOLT REG	N	50	.67	50	†
MC7924CD2T	B D2PAK NEG VOLT REG	N	50	.95	500	†
MC7924CD2TR4	B D2PAK NEG VOLT REG	N	800	.99	800	†
MC7924CT	B LIN3-TERM NEG24V REG	2	50	.55	50	†
MC88LV915TFN	L LOW VOLT CLOCK DRIVER	N	37	21.42	37	
MC88LV926DW	L PLL CLOCK DRIVER	N	38	12.17	38	S B
MC88LV926DWR2	L PLL CLOCK DRIVER	2	1000	12.17	1000	S B
MC88PL117FN	L PLL CMOS CLOCK DR	1	23	32.85	23	B
MC88100RC20	N LAST ORDER DATE:05/02/98	2	1	95.80	1	S B
MC88100RC25	N LAST ORDER DATE:05/02/98	2	1	127.38	1	S B
MC88100RC33	N LAST ORDER DATE:05/02/98	2	1	189.49	1	S B
MC88200RC20	N LAST ORDER DATE:05/02/98	2	1	136.85	1	S B
MC88200RC25	N LAST ORDER DATE:05/02/98	2	1	185.28	1	S B
MC88200RC33	N LAST ORDER DATE:05/02/98	2	1	273.70	1	S B
MC88913D	L FLIP/FLOP MATCH PROP DELA	2	55	10.67	55	S P
MC88913DR2	L FLIP/FLOP MATCH PROP DELA	2	2500	10.75	2500	S P
MC88913N	L FLIP/FLOP MATCH PROP DELA	2	25	10.63	25	S P
MC88914D	L HEX DIVIDE BY2F/F	2	55	10.67	55	S P
MC88914N	L HEX DIVIDE BY2F/F	2	25	10.63	25	S P
MC88915FN55	L LOW SKEW PLL CLOCK	1	37	6.75	37	
MC88915FN55R2	L LOW SKEW PLL CLOCK	1	500	6.57	500	
MC88915FN70	L LOW SKEW PLL CLOCK DR	1	37	6.75	37	
MC88915FN70R2	L LOW SKEW PLL CLOCK DR	N	500	6.57	500	
MC88915TFN100	L I/C LOW SKEW CLOCK DRIVER	1	37	7.83	37	
MC88915TFN100R2	L I/C LOW SKEW CLOCK DRIVER	N	500	7.83	500	
MC88915TFN133	L PLL CLOCK DRIVER	2	37	8.92	37	
MC88915TFN160	L PLL CLOCK DRIVER	N	37	11.67	37	S P
MC88915TFN55	L CMOS LOW SKEW CLOCK DRIVER	N	37	6.75	37	

Type No.	Grp/Description	Per Unit Sugg. Factory				
		Resale Price	Price	Order Incrmt		
PC	Qty					
MC88915TFN55R2	L CMOS LOW SKEW CLOCK DRIVER	N	500	6.57	500	
MC88915TFN70	L CMOS LOW SKEW CLOCK DRIVER	1	37	6.75	37	
MC88915TFN70R2	L CMOS LOW SKEW CLOCK DRIVER	N	500	6.57	500	
MC88916DW70	L I/C LOW SKEW CLOCK DR PLL	1	38	14.63	38	S P
MC88916DW80	L I/C LOW SKEW CLOCK DR PLL	1	38	18.78	38	S P
MC88920DW	L LOW SKEW CMOS CLOCK DR.	2	38	10.15	38	B
MC88920DWR2	L LOW SKEW CMOS CLOCK DR.	2	1000	10.17	1000	B
MC88921DW	L PLL CLOCK DRIVER	N	38	9.84	38	S B
MC916Y3CFT16	J AMCU16BIT MCU	N	24	53.65	24	★ B
MC916Y3CFT16B1	J AMCU16BIT MCU	N	120	53.13	120	★ B
MC92500ZQ	N ATMC PROCESSOR	N	1	131.01	1	B
MDC1000BLT1	A SMBLK SOT23 MOST TURN OFF	2	3000	.30	3000	†
MDC1000CT1	A SMBLK SOT223 T/R	2	1000	.53	1000	†
MDC3105LT1	A SS XSTR	N	3000	.28	3000	†
MGP20N35CL	A TMOS20A350V1GBT NCHAN	N	50	3.20	50	†
MGP20N40CL	A 20AMP400VIGBT	N	50	3.20	50	†
MGP20N60	A 20A600VIGBT	N	50	3.25	50	†
MGRB1018	A SCHOTTKY RECT,10AMP,180V	R	50	6.60	50	†
MGRB1018T4	A SCHOTTKY RECT,10AMP,180V	2	800	4.08	800	†
MGRB2018CT	A SCHOTTKY RECT,20AMP,180V	N	50	13.80	50	†
MGRB2018CTT4	A SCHOTTKY RECT,20AMP,180V	2	800	8.87	800	†
MGRB2025CT	A SCHOTTKY RECT,20AMP,250V	R	50	18.72	50	†
MGRB2025CTT4	A SCHOTTKY RECT,20AMP,250V	2	800	18.14	800	†
MGR1018	A REC,10A,180V,GAAS0-220	R	50	6.40	50	†
MGR2018CT	A TO220,GAAS SCHOTTKY	R	50	13.60	50	†
MGR2025CT	A REC,20A,250V,GAAS0-220	R	50	16.64	50	†
MGSF1N02LT1	A NCHAN SOT23 HDTMOS	2	3000	.50	3000	†
MGSF1N03LT1	A NCHAN SOT23 HDTMOS	2	3000	.50	3000	†
MGSF1P02LT1	A NCHAN SOT23 HDTMOS	2	3000	.54	3000	†
MGSF3441VT1	A P-CHANNEL MOSFET, SMSIG	N	3000	.66	3000	★ †
MGS05N60D	A POWERLUX IGBT (0.5A,600V)	N	1	.67	1	★ †
MGW12N120	A PWR XSTR,12A,1200V,IGBT	N	29	4.20	29	†
MGW12N120D	A XSTRPWR,12A,1200V,IGBT	N	29	5.38	29	†
MGW20N60D	A 20A600VIGBT, DIODE	N	29	5.83	29	†
MGW30N60	A XSTRPWR30A,600V,IGBT	N	29	9.70	29	†
MGY25N120	A PWR XSTR,25A,1200V	N	25	9.90	25	†
MGY30N60D	A XSTRPWR30A,600V,IGBT	N	25	12.60	25	†
MGY40N60	A XSTRPWR40A,600V,IGBT	N	29	18.12	25	†
MGY40N60D	A XSTRPWR40A,600V,IGBT	N	29	19.36	25	†
MHC05SASMXXBBX12	J AMCU	N	1	400.00	1	S
MHC08SASMXXBBX12	J AMCU	N	1	400.00	1	S
MHC11SASMXXBBX12	J AMCU	N	1	400.00	1	S
MHC11SRTEKHXD20	L RTEK2.0 KERNEL	N	1	4000.00	1	★ S
MHC12SASMXXBBX12	J AMCU	N	1	400.00	1	S
MHC12SRTEKHXD20	L RTEK2.0 KERNEL	N	1	4250.00	1	★ S

A = OSPD/Power
 B = Analog/Logic
 J = Transportation
 L = Consumer
 N = Networking
 V = Wireless

S = Proprietary Device
 B = Motorola Blue Chip Program Device
 P = Phoenix Program
 ★ = First Time in Book
 † \$200 Minimum Waived

N = Key New Motorola Device
 R = Key "Focus" Motorola Device

1 = Mature, Stable, High-Volume Device
 2 = Moderate-Volume Device
 3 = Low-Volume Device

COMMERCIAL COMPONENTS

Type No.	Grp/Description	PC	Unit Qty	Sugg. Resale Price	Factory Order Incrmt
MHC16SASMXBBX12	J AMCU	N	1	400.00	1 S
MHC16SRTEKHDX20	J RTEK2.0FORM68HC1623	N	1	4500.00	1 * S
MHL8015	N RF HYBRIDL N	N	10	52.36	10
MHL8018	N RF HYBRIDL N	N	10	52.36	10
MHL8115	N RF HYBRIDL N	N	10	77.00	10
MHL8118	N RFL HYBRIDL N	N	1	77.00	1
MHL9125	N RFLAMP20DBM-STRIP	N	10	80.08	10
MHL9128	N RF LINEAR AMP FLG PKG	N	10	80.08	10
MHPM6B10A120D	J IGBT PWR MOD,10A,1200V	N	1	42.25	1
MHPM6B10A60D	J IGBT PWR MOD,10A,600V	N	1	23.84	1
MHPM6B10A60D1	J IGBT,PWR MOD,10A,600V	N	1	29.35	1
MHPM6B15A120D	J IGBT PWR MOD,15A,1200V	N	1	52.63	1
MHPM6B20A60D	J IGBT PWR MOD,20A,600V	N	1	32.37	1
MHPM6B5A120D	J IGBT PWR MOD,5A,1200V	N	1	32.49	1
MHPM6B5A120D1	J IGBT,PWR MOD,5.0A,1200V	N	1	36.81	1
MHPM7A12A120A	J IGBT PWR MOD,12A,1200V	N	1	46.24	1
MHPM7A15A60A	J IGBT PWR MOD,15A,600V	N	1	42.12	1
MHPM7A16A120B	J 16A,1200V IGBT PWR MOD	N	1	58.15	1
MHPM7A20A60A	J IGBT PWR MOD,20A,600V	N	1	49.40	1
MHPM7A25A120B	J IGBT PWR MODULE,25A,1200V	N	1	80.56	1
MHPM7A30A60B	J IGBT PWR MOD,30A,600V	N	1	54.43	1
MHPM7A8A120A	J IGBT PWR MOD,8A,1200V	N	1	29.51	1
MHPM7B12A120A	J IGBT PWR MODULE	N	1	44.66	1
MHPM7B15A60A	J IGBT PWR MODULE,15A,600	N	1	42.12	1
MHPM7B16A120B	J IGBT PWR MODULE,16A,1200V	N	1	55.99	1
MHPM7B20A60A	J IGBT PWR MODULE,20A,600V	N	1	38.42	1
MHPM7B25A120B	J IGBT PWR MOD,25A,1200V	N	1	78.72	1
MHPM7B30A60B	J IGBT PWR MODULE	N	1	52.96	1
MHPM7B8A120A	J IGBT PWR MODULE,8A,1200V	N	1	27.96	1
MHW1184L	N LAST ORDER DATE:05/10/98	N	1	25.74	1
MHW1224	N RF LINEAR AMPL FLANGE PKG	N	1	27.17	1 *
MHW1254L	N RF LINEAR AMP FLANGE PKG	N	1	28.60	1
MHW1304L	N RF LINEAR AMP FLANGE PKG	N	1	31.46	1
MHW1815	N RF PWR MOD	N	7	171.60	7
MHW1915	N UHF SILICON FET PWR AMP	N	7	171.60	7
MHW1916	N RF PWR MODULE	N	7	171.60	7
MHW2707-001	V RF POWER MODULE	N	11	30.03	11
MHW2707A1	V RF PWR MODULE	N	11	35.75	11 *
MHW2821-001	V RF LINEAR AMP FLG PKG	N	10	42.90	10
MHW2821-002	V RF LINEAR AMP FLG PKG	N	10	42.90	10
MHW3342	N RF LINEAR AMPL FLANGE PKG	2	50	30.80	50
MHW5182	N RF LINEAR AMPL FLANGE PKG	2	50	27.17	50
MHW5182A	N RF LINEAR AMPL FLANGE PKG	N	50	27.17	50
MHW5185	N RF LINEAR AMPL FLANGE PKG	2	50	35.75	50
MHW5185B	N RF LINEAR AMPL FLANGE PKG	N	1	35.75	1

Type No.	Grp/Description	PC	Unit Qty	Sugg. Resale Price	Factory Order Incrmt
MHW5222A	N RF LINEAR AMPL FLANGE PKG	2	50	27.17	50
MHW5342A	N RF LINEAR AMPL FLANGE PKG	1	50	32.89	50
MHW590	N RF LINEAR AMPL FLANGE PKG	2	50	32.34	50
MHW591	N LAST ORDER DATE:05/10/98	2	50	38.50	50
MHW592	N LAST ORDER DATE:05/10/98	2	1	41.60	1
MHW593	N LAST ORDER DATE:05/10/98	2	1	41.60	1
MHW607-001	V RF PWR MODULE	2	11	36.96	11
MHW6182	N RF LINEAR AMPL FLANGE PKG	2	50	27.89	50
MHW6182-006	N RF LINEAR AMP FLG PKG	N	1	32.89	1
MHW6185	N RF LINEAR AMPL FLANGE PKG	2	50	38.61	50
MHW6185-6A	N RF LINEAR AMPL FLANGE PKG	N	50	41.47	50
MHW6185B	N RF LINEAR AMPL FLANGE PKG	N	1	38.61	1
MHW6205	N LAST ORDER DATE:05/10/98	N	1	44.33	1
MHW6205-6A	N RF LINEAR AMP FLANGE PKG	N	50	41.47	50
MHW6222	N RF LINEAR AMPL FLANGE PKG	2	1	30.03	1
MHW6222-006	N RF LINEAR AMP FLG PKG	N	1	31.46	1
MHW6225	N LAST ORDER DATE:05/10/98	N	1	47.19	1
MHW6272	N CATV F-AMPL550MHZ27DB	2	1	35.75	1
MHW6342	N RF MODULE	2	1	38.61	1
MHW7142	N RF LINEAR AMPL FLNG PKG	N	1	37.18	1
MHW7182	N RF LINEAR AMP FLG PKG	N	1	37.18	1
MHW7185A	N LAST ORDER DATE:11/05/98	N	1	58.63	1
MHW7185C	N RF LINEAR MODULE	N	1	45.76	1 *
MHW7205A	N LAST ORDER DATE:11/05/98	N	50	62.92	50
MHW7205C	N RF LINEAR AMPLIFIER	N	1	48.62	1 *
MHW7222	N RF LINEAR AMP-FLANGE PKG	N	1	40.04	1
MHW7242	N RF LINEAR POWER MOD	N	50	42.90	50
MHW7272	N RF LINEAR AMP FLG PKG	N	50	45.76	50
MHW7292	N RF LINEAR AMP FLG PKG	N	50	48.62	50
MHW803-003	V RF POWER AMPLIFIER	2	11	49.73	11
MHW808A3	V 800MHZ PWR AMPL7.5W,04W	2	10	70.07	10
MHW812A3	V RF MODULE	2	10	41.60	10
MHW8142	N RF LINEAR AMPL FLG PKG	N	1	42.90	1
MHW8182	N RF POWER AMPL	N	1	42.90	1
MHW8185	N RF LINEAR MODULE	N	1	51.48	1 *
MHW820-003	V LAST ORDER DATE:11/05/98	2	8	80.10	8
MHW8205	N RF LINEAR AMPLIFIER	N	1	54.34	1 *
MHW8222	N RF LINEAR AMPL FLANGE PKG	N	50	45.76	50
MHW8242	N RF LINEAR AMP FLG PKG	N	50	48.62	50
MHW8272	N RF LINEAR AMP FLG PKG	N	50	51.48	50
MHW8292	N RF LINEAR AMP FLG PKG	N	50	54.34	50
MHW913	V RF PWR AMPL FLANGE PKG	N	10	42.90	10
MHW914	V RF POWER AMPL FLANGE PKG	2	8	60.80	8
MHW9142	N RF LINEAR AMPL FLG PKG	N	1	48.62	1
MHW916	N RF PWR AMP FLANGE PKG	N	10	62.92	10

A = OSPD/Power
 B = Analog/Logic
 J = Transportation
 L = Consumer
 N = Networking
 V = Wireless

S = Proprietary Device
 B = Motorola Blue Chip Program Device
 P = Phoenix Program
 * = First Time in Book
 † \$200 Minimum Waived

N = Key New Motorola Device
 R = Key "Focus" Motorola Device

1 = Mature, Stable, High-Volume Device
 2 = Moderate-Volume Device
 3 = Low-Volume Device

EFFECTIVE DATE: JANUARY 10, 1998

COMMERCIAL COMPONENTS

Type No.	Grp/Description	Per Unit Sugg. Factory			
		Resale Price	Price	Order	
PC	Qty	Price	Incrmnt		
MHW9182	N RF POWERAMPL	N	1	48.62	1
MHW9242	N RF MODULES	N	50	54.34	50
MHW927B	V RF POWERAMPL FLANG PKG	2	9	56.24	9
MHW930	N SILICON,UHF FET PWR AMP	N	10	85.80	10 *
MJD112	A PWR2A100V DARNPN DPAK	2	75	.62	75
MJD112-001	A PWR STRAIGHT LEAD MJD112	2	75	.70	75
MJD112T4	A PWR TAPE AND REEL MJD112	N	2500	.66	2500
MJD117	A PWR2A100V DARNPN DPAK	2	75	.62	75
MJD117-001	A PWR STRAIGHT LEAD MJD117	2	75	.70	75
MJD117T4	A PWR TAPE AND REEL MJD117	2	2500	.47	2500
MJD122	A PWR8A100V NPND DPAK	3	75	1.56	75
MJD122T4	A PWR TAPE AND REEL MJD122	2	2500	.56	2500
MJD127	A PWR8A100V DARNPN	2	75	.78	75
MJD127T4	A PWR TAPE AND REEL MJD127	2	2500	.46	2500
MJD200	A PWR5A25V DISNPN DPAK	3	75	1.83	75
MJD200-001	A PWR STRAIGHT LEAD MJD200	2	75	1.14	75
MJD200RL	A PWR TAPE AND REEL MJD200	2	1800	.72	1800
MJD200T4	A PWR TAPE AND REEL MJD200	N	2500	1.90	2500
MJD210	A PWR5A25V DISNPN DPAK	2	75	.70	75
MJD210RL	A PWR TAPE AND REEL MJD210	2	1800	.72	1800
MJD210T4	A PWR TAPE AND REEL MJD210	2	2500	.57	2500
MJD243	A PWR4A100V DISNPN DPAK	2	75	1.54	75
MJD243T4	A PWR TAPE AND REEL MJD243	2	2500	.64	2500
MJD253T4	A PWR TAPE AND REEL MJD253	2	2500	.67	2500
MJD2955	A PWR10A60V DISNPN DPAK	2	75	.64	75
MJD2955-001	A PWR STRAIGHT LEAD MJD2955	3	75	1.79	75
MJD2955T4	A PWR TAPE AND REEL MJD2955	2	2500	.50	2500
MJD3055	A PWR10A60V DISNPN DPAK	2	75	.62	75
MJD3055T4	A PWR TAPE AND REEL MJD3055	2	2500	.47	2500
MJD31C	A PWR3A100V DISNPN DPAK	2	75	.42	75
MJD31CRL	A PWR TAPE AND REEL MJD31C	3	1800	1.24	1800
MJD31CT4	A PWR TAPE AND REEL MJD31C	2	2500	.33	2500
MJD31C1	A PWR STRAIGHT LEAD MJD31C	N	75	.50	75
MJD31T4	A PWR TAPE AND REEL MJD31	2	2500	.33	2500
MJD32C	A PWR3A100V DISNPN DPAK	3	75	1.00	75
MJD32CRL	A PWR TAPE AND REEL MJD32C	3	1800	1.24	1800
MJD32CT4	A PWR TAPE AND REEL MJD32C	N	2500	.36	2500
MJD32C1	A PWR STRAIGHT LEAD MJD32C	3	75	1.00	75
MJD32RL	A PWR TAPE AND REEL MJD32	2	1800	.49	1800
MJD32T4	A PWR TAPE AND REEL MJD32	2	2500	.36	2500
MJD340	A PWR.5A300V NPN DPAK	3	75	2.04	75
MJD340RL	A PWR TAPE AND REEL MJD340	3	1800	2.38	1800
MJD340T4	A PWR TAPE AND REEL MJD340	2	2500	.69	2500
MJD350	A PWR.5A300V DISPNDPAK	2	75	1.08	75
MJD350T4	A PWR TAPE AND REEL MJD350	2	2500	.86	2500

Type No.	Grp/Description	Per Unit Sugg. Factory			
		Resale Price	Price	Order	
PC	Qty	Price	Incrmnt		
MJD41CRL	A PWR TAPE AND REEL MJD41C	3	1800	1.90	1800
MJD41CT4	A PWR TAPE AND REEL MJD41C	N	2500	.66	2500
MJD41C1	A PWR STRAIGHT LEAD MJD41C	3	75	1.96	75
MJD42C	A PWR6A100V PNP DPAK	3	75	1.36	75
MJD42CRL	A PWR TAPE AND REEL MJD42C	3	1800	1.76	1800
MJD42CT4	A PWR TAPE AND REEL MJD42C	2	2500	.51	2500
MJD42C1	A PWR STRAIGHT LEAD MJD42C	3	75	1.52	75
MJD44E3T4	A PWR TAPE AND REEL MJD44E3	N	2500	1.28	2500
MJD44H1	A PWR10A80V PLANPN DPAK	2	75	1.24	75
MJD44H1-001	A PWR ST LEAD MJD44H1	2	75	1.32	75
MJD44H1RL	A PWR TAPE & REEL MJD44H1	3	1800	2.48	1800
MJD44H1T4	A PWR TAPE & REEL MJD44H1	2	2500	.92	2500
MJD45H1	A PWR10A80V PLANPN DPAK	2	75	1.30	75
MJD45H1-001	A PWR ST LEAD MJD45H1	2	75	1.38	75
MJD45H1RL	A PWR TAPE & REEL MJD45H1	3	1800	2.86	1800
MJD45H1T4	A PWR TAPE & REEL MJD45H1	2	2500	.93	2500
MJD47	A PWR1A250V SMNPN DPAK	2	75	.68	75
MJD47T4	A PWR TAPE & REEL MJD47	N	2500	.98	2500
MJD50	A PWR1A400V SMNPN DPAK	2	75	.72	75
MJD50T4	A PWR TAPE AND REEL MJD50	2	2500	.57	2500
MJD5731T4	A PWR TAPE AND REEL MJD5731	2	2500	.96	2500
MJD6039T4	A PWR TAPE AND REEL MJD6039	N	2500	.74	2500
MJE13003	A PWR2A400V SMNPN C77	2	500	.62	500
MJE13005	A PWR4A400V SM1 NPN TO220	2	50	1.20	50
MJE13007	A PWR8A400V SM1 NPN TO220	1	50	1.40	50
MJE13009	A PWR12A400V NPNTO220	1	50	2.00	50
MJE1320	A PWR2A900V SMNPNTO220	2	50	2.70	50
MJE15028	A PWR8A120V PLANPN TO220	2	50	1.39	50
MJE15029	A PWR8A120V PLANPN TO220	2	50	1.60	50
MJE15030	A PWR8A150V PLANPN TO220	1	50	1.34	50
MJE15031	A PWR8A150V PLANPN TO220	1	50	1.40	50
MJE15032	A XSTR,PWR NPN,AUDIO DRIVER	N	50	1.60	50
MJE15033	A XSTR,PNP PWR,AUDIO DRIVER	N	50	1.60	50
MJE16002	A PWR5A450V SM3 NPN TO220	1	50	1.38	50
MJE16004	A PWR5A450V SM3 NPN TO220	2	50	1.60	50
MJE16204	A PWR5A550V HRM NPN TO220	3	50	2.76	50
MJE170	A PWR3A40V PNP C77	2	500	.29	500
MJE171	A PWR3A60V PNP C77	2	500	.29	500
MJE172	A PWR3A80V PNP C77	1	500	.29	500
MJE180	A PWR3A40V NPN C77	1	500	.31	500
MJE18002	A PWR2A450V NPN TO220	2	50	.64	50
MJE18004	A PWR5A1000V SMNPN TO220	2	50	.74	50
MJE18006	A PWR8A450V NPN TO220	2	50	.82	50
MJE18008	A PWR10A450V NPNTO220	2	50	1.05	50
MJE18009	A (10A,100V) SWITCHMODE NPN	N	50	1.84	50

A = OSPD/Power
 B = Analog/Logic
 J = Transportation
 L = Consumer
 N = Networking
 V = Wireless

S = Proprietary Device
 B = Motorola Blue Chip Program Device
 P = Phoenix Program
 * = First Time in Book
 † = \$200 Minimum Waived

N = Key New Motorola Device
 R = Key "Focus" Motorola Device

1 = Mature, Stable, High-Volume Device
 2 = Moderate-Volume Device
 3 = Low-Volume Device

COMMERCIAL COMPONENTS

Type No.	Grp/Description	Per Unit Sugg. Factory			Type No.	Grp/Description	Per Unit Sugg. Factory					
		PC	Qty	Price			Order	PC	Qty	Price	Order	
MJE181	A PWR3A60V NPN C77	2	500	.29	500	MJF45H11	A PWR10A60V NPNT0220FP	2	50	1.54	50	
MJE182	A PWR3A80V NPN C77	1	500	.29	500	MJF47	A PWR1A250V NPNT0220FP	2	50	1.20	50	
MJE18204	A 5A,1200V) NPN PWR TRANS	N	50	1.28	50	MJF6107	A PWR8A80V PNP TO220FP	3	50	1.94	50	
MJE18206	A (8A,1200V) NPN POWER TRANS	N	50	1.48	50	MJF6388	A PWR10A100V NPND TO220FP	2	50	1.00	50	
MJE200	A PWR5A25V NPN C77	1	500	.47	500	MJF6668	A PWR10A100V PNPDP TO220FP	2	50	1.30	50	
MJE210	A PWR5A25V PNP C77	1	50	.40	50	MJH10012	A PW10A400V DAR NPNT0218	2	30	3.50	30	
MJE243	A PWR4A100V NPNC77	1	500	.62	500	MJH11017	A PWR15A150V DAPNP TO218	2	30	7.50	30	
MJE253	A PWR4A100V PNPC77	1	500	.67	500	MJH11018	A PW20A150V DAR NPNT0218	2	30	6.60	30	
MJE270	A PWR2A100V NPND C77	2	500	.85	500	MJH11019	A PW20A200V DAR NPNT0218	2	30	8.20	30	
MJE271	A PWR2A100V PNPDC77	2	500	.82	500	MJH11020	A PW20A200V DAR NPNT0218	2	30	4.50	30	
MJE2955T	A PWR10A60V DIS PNP TO220	1	50	.72	50	†	MJH11021	A PW20A250V DAR PNP TO218	2	30	5.20	30
MJE3055T	A PWR10A60V DIS NPN TO220	1	50	.70	50	†	MJH11022	A PWR20A250V NPN TO218	2	30	8.25	30
MJE340	A PWR1A300V NPNC77	1	500	.45	500	MJH16006A	A PWR8A500V SM3 NPN TO218	2	30	4.00	30	
MJE3439	A PWR1A350V NPNC77	2	500	.54	500	MJH6284	A PW20A100V DAR NPNT0218	2	30	5.04	30	
MJE344	A PWR1A200V NPNC77	2	500	.60	500	MJH6287	A PW20A100V DAR PNP TO218	1	30	5.24	30	
MJE350	A PWR1A300V PNPC77	1	500	.54	500	MJL1302A	A PWR15A200V PNP TO3PBL	1	25	5.40	25	
MJE371	A PWR4A40V PNP C77	1	500	.54	500	MJL21193	A PWR16A250V PNP TO3PBL	1	25	5.00	25	
MJE4343	A PWR16A160V DINPNT0218	2	30	4.74	30	MJL21194	A PWR16A250V NPN TO3PBL	1	25	5.00	25	
MJE4353	A PWR16A160V DIPNP TO218	2	30	3.04	30	MJL3281A	A PWR15A200V NPN TO3PBL	1	25	5.40	25	
MJE521	A PWR4A40V NPNC77	1	500	.42	500	MJW16010	A PWR15A200V NPN TO247	2	30	4.68	30	
MJE5731	A PWR1A350V DIS PNP TO220	2	50	1.50	50	MJW16010A	A PWR15A500V NPN TO247	2	30	5.76	30	
MJE5731A	A PWR1A375V PNP TO220	3	50	3.11	50	MJW16012	A PWR15A450V NPN TO247	2	30	6.24	30	
MJE5740	A PWR8A300V DAR NPNT0220	2	50	1.58	50	MJW16018	A PWR10A800V NPN TO247	1	30	7.20	30	
MJE5742	A PWR8A400V DAR NPNT0220	1	50	2.16	50	MJW16206	A PWR12A500V NPN TO247	2	30	6.00	30	
MJE5850	A PWR8A300V DIS PNP TO220	1	50	5.18	50	MJW16212	A PWR10A650V NPN TO247	2	30	10.60	30	
MJE5851	A PWR8A350V DIS PNP TO220	2	50	5.18	50	MJW21191	A XSTR,PNP AUDIO OUTPUT	N	30	2.50	30 *	
MJE5852	A PWR8A400V DIS PNP TO220	1	50	3.10	50	MJW21192	A XSTR,NPN COMPAUDIO OUTPT	N	30	2.50	30 *	
MJE700	A PWR4A60V PNPDC77	1	500	.50	500	MJ10005	A PWR20A400V DAR NPNT03	1	100	4.34	100	
MJE702	A PWR4A80V PNPDC77	2	500	.43	500	MJ10007	A PWR10A400V DAR NPNT03	2	100	5.90	100	
MJE703	A PWR4A80V PNPDC77	2	500	.43	500	MJ10009	A PWR20A500V DAR NPNT03	2	100	9.50	100	
MJE800	A PWR4A60V NPND C77	1	500	.33	500	MJ10012	A PWR10A400V DAR NPNT03	1	100	2.51	100	
MJE802	A PWR4A80V NPND C77	1	500	.33	500	MJ10015	A PWR50A400V DAR NPNT03	2	100	17.05	100	
MJE803	A PWR4A80V NPND C77	2	500	.33	500	MJ10016	A PWR50A500V DAR NPNT03	1	100	20.90	100	
MJE9780	A PWR3A150V PNP TO220	2	50	1.50	50	†	MJ10020	A PWR60A200V DAR NPNT03	2	100	10.10	100
MJF122	A PWR5A100V DAR NPNT220FP	1	50	.74	50	MJ10021	A PWR60A250V DAR NPNT03	2	100	11.60	100	
MJF127	A PWR5A100V PNP TO220FP	1	50	.74	50	MJ10023	A PWR40A400V DAR NPNT03	2	100	12.10	100	
MJF13007	A PWR8A400V NPNT0220FP	2	50	1.54	50	MJ11012	A PWR30A60V DAR NPNT03	2	100	3.10	100	
MJF15030	A PWR8A150V NPN TO220FP	2	50	2.64	50	MJ11015	A PWR30A120V DAR PNP TO3	2	100	6.20	100	
MJF15031	A PWR8A150V PNP TO220FP	2	50	2.64	50	MJ11016	A PWR30A120V DAR NPNT03	2	100	3.64	100	
MJF18004	A PWR5A450V NPNT0220FP	2	50	1.49	50	MJ11021	A PWR15A250V DAR PNP TO3	2	100	7.81	100	
MJF2955	A PWR10A60V PNP TO220FP	2	50	1.24	50	MJ11022	A PWR15A250V DAR NPNT03	2	100	6.91	100	
MJF3055	A PWR10A60V NPN TO220FP	2	50	.90	50	MJ11028	A PWR50A60V DAR NPNT03	2	100	4.96	100	
MJF31C	A PWR3A100V NPN TO220FP	2	50	.78	50	MJ11029	A PWR50A60V DAR PNP TO3	2	100	6.82	100	
MJF32C	A PWR3A100V PNPT0220FP	3	50	1.68	50	MJ11030	A PWR50A90V DAR NPNT03	2	100	6.63	100	
MJF44H11	A PWR10A60V NPNT0220FP	2	50	1.40	50	MJ11032	A PWR50A120V DAR NPNT03	1	100	6.20	100	

A = OSPD/Power
 B = Analog/Logic
 J = Transportation
 L = Consumer
 N = Networking
 V = Wireless

S = Proprietary Device
 B = Motorola Blue Chip Program Device
 P = Phoenix Program
 * = First Time in Book
 † \$200 Minimum Waived

N = Key New Motorola Device
 R = Key "Focus" Motorola Device

1 = Mature, Stable, High-Volume Device
 2 = Moderate-Volume Device
 3 = Low-Volume Device

COMMERCIAL COMPONENTS

Type No.	Grp/Description	Per Unit Sugg. Factory			
		Resale Price	Price	Order	
PC	Qty	Price	Incrrmnt		
MJ11033	A PWR50A120V DAR PNP TO3	1	100	6.67	100
MJ13333	A PWR20A400V SM1 NPN TO3	2	100	4.65	100
MJ14001	A PWR60A60V DIS PNP TO3	2	100	12.80	100
MJ14002	A PWR60A80V DIS NPNTO3	2	100	6.59	100
MJ14003	A PWR60A80V DIS PNP TO3	2	100	13.95	100
MJ15001	A PWR15A140V DIS NPN TO3	2	100	2.73	100
MJ15002	A PWR15A140V DIS PNP TO3	2	100	2.73	100
MJ15003	A PWR20A140V DIS NPN TO3	1	100	2.64	100
MJ15004	A PWR20A140V DIS PNP TO3	1	100	3.41	100
MJ15011	A PWR10A250V DIS NPN TO3	2	100	2.98	100
MJ15015	A PWR15A120V DIS NPN TO3	2	100	1.57	100
MJ15016	A PWR15A120V DIS PNP TO3	2	100	1.66	100
MJ15020	A PWR4A250V DIS NPNTO3	2	100	3.44	100
MJ15021	A PWR4A250V DIS PNP TO3	2	100	3.64	100
MJ15022	A PWR16A200V DIS NPN TO3	1	100	3.02	100
MJ15023	A PWR16A200V DIS PNP TO3	1	100	3.30	100
MJ15024	A PWR16A250V DIS NPN TO3	1	100	3.02	100
MJ15025	A PWR16A250V DIS PNP TO3	1	100	3.66	100
MJ16010	A PWR15A450V SM3 NPN TO3	2	100	3.72	100
MJ16012	A PWR15A450V SM3 NPN TO3	2	100	5.04	100
MJ16018	A PWR10A800V SM3 NPN TO3	1	100	5.74	100
MJ16020	A PWR30A450V NPN TO204	2	100	9.15	100
MJ16022	A PWR30A450V NPN TO204	2	100	10.10	100
MJ16110	A PWR15A400V SM3 NPN TO3	2	100	4.65	100
MJ21193	A PWR16A250V PNP TO3	2	100	3.95	100
MJ21194	A PWR16A250V NPN TO3	2	100	3.95	100
MJ2501	A PWR10A80V DAR PNP TO3	2	100	2.56	100
MJ2955	A PWR15A60V DIS PNP TO3	2	100	1.29	100
MJ3001	A PWR10A80V DIS NPN TO3	2	100	2.33	100
MJ423	A PWR10A325V DIS NPN TO3	2	100	3.80	100
MJ4502	A PWR30A100V DIS PNP TO3	2	100	2.64	100
MJ802	A PWR30A90V DIS NPNTO3	2	100	2.02	100
MLP1N06CL	A SMRT DISC0.75R60V TO220	N	50	9.61	50 S †
MMAD1103	A LAST ORDER DATE:09/20/98	1	55	3.04	55 †
MMAD1103R2	A LAST ORDER DATE:09/20/98	2	2500	3.12	2500 †
MMAD1107	A LAST ORDER DATE:09/20/98	3	55	9.82	55 †
MMAD1107R1	A LAST ORDER DATE:09/20/98	3	500	5.03	500 †
MMAD1108	A LAST ORDER DATE:09/20/98	1	48	2.82	48 †
MMAD1108R1	A LAST ORDER DATE:09/20/98	1	500	2.90	500 †
MMAD1108R2	A LAST ORDER DATE:09/20/98	3	2500	4.39	2500 †
MMAD1109	A LAST ORDER DATE:09/20/98	2	55	2.82	55 †
MMAD130	A LAST ORDER DATE:09/20/98	3	55	13.20	55 †
MMAS40G10D	J ACCELEROMETER +-40G	N	25	17.90	25 B
MMBD1000LT1	A DIODE SWITCHING	2	3000	.16	3000 †
MMBD1005LT1	A MINI SWIT DI COMANODE	2	3000	.16	3000 †

Type No.	Grp/Description	Per Unit Sugg. Factory			
		Resale Price	Price	Order	
PC	Qty	Price	Incrrmnt		
MMBD101LT1	A SS DIODE SOT23 T/R3K	2	3000	.44	3000 †
MMBD1010LT1	A MINI SWIT DIODE COMM CATH	2	3000	.16	3000 †
MMBD2000T1	A DIODE SWITCHING	2	3000	.16	3000 †
MMBD2005T1	A MINI SWIT DI COMANODE	2	3000	.16	3000 †
MMBD2010T1	A MINI SWIT DIODE COMM CATH	2	3000	.16	3000 †
MMBD2837LT1	A SS SWIT DIO SOT23 T/R3K	2	3000	.14	3000 †
MMBD301LT1	A SS DIODE SOT23 T/R3K	1	3000	.44	3000 †
MMBD352LT1	A SS DIODE SOT23 T/R3K	1	3000	.66	3000 †
MMBD352WT1	A DUSERSCHOTDIO,SOT-323	N	3000	.11	3000 †
MMBD353LT1	A SS DIODE SOT23 T/R3K	3	3000	1.32	3000 †
MMBD355LT1	A SOT23 DUAL SCHOTTKY DIODE	2	3000	.26	3000 †
MMBD452LT1	A SOT23 DUAL SCHOTTKY DIODE	2	3000	.26	3000 †
MMBD6050LT1	A SS DIODE SOT23 T/R3K	1	3000	.14	3000 †
MMBD6100LT1	A SS DL DIODE SOT23 T/R3K	2	3000	.14	3000 †
MMBD7000LT1	A SS DL DIODE SOT23 T/R3K	1	3000	.14	3000 †
MMBD701LT1	A SS DIODE SOT23 T/R3K	1	3000	.44	3000 †
MMBD770T1	A DIODE SCHOTTKY SC70 PKG	N	3000	.44	3000 †
MMBD914LT1	A SS DIODE SOT23 T/R3K	1	3000	.13	3000 †
MMBFJ175LT1	A SS JFET P-CHAN SOT23 T/R	2	3000	.40	3000 †
MMBFJ177LT1	A SS JFET SOT23 T/R3K	1	3000	.40	3000 †
MMBFJ309LT1	A SS JFET SOT23 T/R3K	2	3000	.34	3000 †
MMBFJ310LT1	A SS JFET SOT23 T/R3K	1	3000	.34	3000 †
MMBFU310LT1	A SS JFET SOT23 T/R3K	2	3000	.34	3000 †
MMBF0201NLT1	A N-CHAN, MOS PWR FET	2	3000	.54	3000 †
MMBF0202PLT1	A P-CHAN, MOS PWR FET	2	3000	.60	3000 †
MMBF170LT1	A SSTMOS SOT23 T/R3K	1	3000	.70	3000 †
MMBF2201NT1	A N-CHAN MOS PWR FET	N	3000	.38	3000 †
MMBF2202PT1	A P-CHAN MOS PWR FET	N	3000	.44	3000 †
MMBF4391LT1	A SS JFET SOT23 T/R3K	2	3000	.40	3000 †
MMBF4392LT1	A SS JFET SOT23 T/R3K	2	3000	.40	3000 †
MMBF4393LT1	A SS JFET SOT23 T/R3K	1	3000	.34	3000 †
MMBF4416LT1	A SS JFET SOT23 T/R3K	2	3000	.34	3000 †
MMBF4860LT1	A LAST ORDER DATE:06/26/98	N	3000	.54	3000 †
MMBF5457LT1	A SS JFET SOT-23 T/R3K	N	3000	.96	3000 †
MMBF5459LT1	A LAST ORDER DATE:06/26/98	2	3000	.54	3000 †
MMBF5460LT1	A SS JFET SOT-23 T/R3K	2	3000	.40	3000 †
MMBF5484LT1	A SS JFET SOT23 T/R3K	2	3000	.34	3000 †
MMBR2857LT1	V RF NPN LO PWR SOT-23	2	3000	.37	3000
MMBR5031LT1	V RF NPN LO PWR SOT-23 T/R	2	3000	.49	3000
MMBR5179LT1	V RF NPN LO PWR SOT-23 T/R	1	3000	.37	3000
MMBR521LT1	V RF PNP LO PWR SOT23	2	3000	.82	3000
MMBR571LT1	V RF NPN LO PWR SOT-23 T/R	2	3000	.51	3000
MMBR901LT1	V RF NPN LO PWR SOT-23 T/R	1	3000	.26	3000
MMBR911LT1	V RF NPN LO PWR SOT-23 T/R	2	3000	.34	3000
MMBR931LT1	V RF NPN LO PWR SOT-23 T/R	2	3000	.54	3000

A = OSPD/Power
 B = Analog/Logic
 J = Transportation
 L = Consumer
 N = Networking
 V = Wireless

S = Proprietary Device
 B = Motorola Blue Chip Program Device
 P = Phoenix Program
 * = First Time in Book
 † \$200 Minimum Waived

N = Key New Motorola Device
 R = Key "Focus" Motorola Device

1 = Mature, Stable, High-Volume Device
 2 = Moderate-Volume Device
 3 = Low-Volume Device

COMMERCIAL COMPONENTS

Type No.	Grp/Description	Per PC	Unit Qty	Sugg. Resale Price	Factory Order Incrrmnt
MMBR941BLT1	V RFLPWRSOT23	2	3000	.64	3000
MMBR941LT1	V RFNPNLOPWR SOT-23 T/R	2	3000	.32	3000
MMBR951LT1	V RFNPNLOPWR SOT-23 T/R	2	3000	.34	3000
MMBTA05LT1	A SSDRIVER SOT23 T/R3K	3	3000	.42	3000 †
MMBTA06LT1	A SSDRIVER SOT23 T/R3K	1	3000	.17	3000 †
MMBTA13LT1	A SSDARL NPN SOT23 T/R3K	2	3000	.16	3000 †
MMBTA14LT1	A SSDARL NPN SOT23 T/R3K	1	3000	.16	3000 †
MMBTA42LT1	A SSHIVOLT SOT23 T/R3K	1	3000	.19	3000 †
MMBTA55LT1	A SSDRIVER SOT23 T/R3K	3	3000	.42	3000 †
MMBTA56LT1	A SSDRIVER SOT23 T/R3K	1	3000	.17	3000 †
MMBTA63LT1	A SSDARL SOT23 T/R3K	2	3000	.16	3000 †
MMBTA64LT1	A SSDARL SOT23 T/R3K	2	3000	.16	3000 †
MMBTA92LT1	A SSHIVOLT SOT23 T/R3K	1	3000	.19	3000 †
MMBTA93LT1	A SSHIVOLT SOT23 T/R3K	3	3000	.49	3000 †
MMBTH10LT1	A SSVHFMIXER SOT23 T/R3K	1	3000	.26	3000 †
MMBTH17LT1	A SSCATV NPN SOT23 T/R3K	3	3000	.65	3000 †
MMBTH24LT1	A SSVHF MIXER SOT23 T/R3K	2	3000	.28	3000 †
MMBTH69LT1	A LAST ORDER DATE:09/20/98	2	3000	.36	3000 †
MMBTH81LT1	A LAST ORDER DATE:09/20/98	1	3000	.28	3000 †
MMBT1010LT1	A LOWPWR XSTR	2	3000	.17	3000 †
MMBT2222ALT1	A SSGPNPN SOT23 T/R3K	1	3000	.15	3000 †
MMBT2222ALT1S	A SSP SOT23 NPN	1	3000	.15	3000 †
MMBT2222LT1	A SSGPNPN SOT23 T/R3K	2	3000	.15	3000 †
MMBT2369ALT1	A SSGPNPN SOT23 T/R3K	1	3000	.19	3000 †
MMBT2369LT1	A SSGPNPN SOT23 T/R3K	2	3000	.19	3000 †
MMBT2484LT1	A SSGPNPN SOT23 T/R3K	3	3000	.36	3000 †
MMBT2907ALT1	A SSGENPURPNP SOT-23 T/R	1	3000	.15	3000 †
MMBT2907LT1	A SSGPNPN SOT23 T/R3K	2	3000	.15	3000 †
MMBT3640LT1	A SSWITCH SOT23 T/R3K	2	3000	.28	3000 †
MMBT3904LT1	A SSGPNPN SOT23 T/R3K	1	3000	.14	3000 †
MMBT3904LT1S	A SSP SOT23 NPN	2	3000	.14	3000 †
MMBT3904LT3	A SMSIGXSTRMINIBLOC	210000		.14	10000 †
MMBT3906LT1	A SSGPNPN SOT23 T/R3K	1	3000	.14	3000 †
MMBT404ALT1	A XSTR SMSIG SOT23 PNP	2	3000	.36	3000 †
MMBT4124LT1	A SSGPNPN SOT23 T/R3K	3	3000	.34	3000 †
MMBT4125LT1	A SSGPNPN SOT23 T/R3K	3	3000	.34	3000 †
MMBT4401LT1	A SSWITCH SOT23 T/R3K	1	3000	.15	3000 †
MMBT4403LT1	A SSWITCH SOT23 T/R3K	1	3000	.15	3000 †
MMBT4403LT1S	A SSP SOT23 PNP	2	3000	.15	3000 †
MMBT5087LT1	A SLOWNOISE SOT23 T/R3K	1	3000	.13	3000 †
MMBT5088LT1	A SLOWNOISE SOT23 T/R3K	2	3000	.14	3000 †
MMBT5089LT1	A SLOWNOISE SOT23 T/R3K	1	3000	.14	3000 †
MMBT5401LT1	A SSHIVOLT SOT23 T/R3K	2	3000	.23	3000 †
MMBT5550LT1	A SSHIVOLT SOT23 T/R3K	2	3000	.23	3000 †
MMBT5551LT1	A SSNPN SOT23 TAPE/REEL3K	1	3000	.23	3000 †

Type No.	Grp/Description	Per PC	Unit Qty	Sugg. Resale Price	Factory Order Incrrmnt
MMBT6427LT1	A SSDARL SOT23 T/R3K	2	3000	.16	3000 †
MMBT6429LT1	A SSNPN SOT23 T/R3K	2	3000	.14	3000 †
MMBT6517LT1	A SSHIVOLT SOT23 T/R3K	2	3000	.30	3000 †
MMBT6520LT1	A SSHIVOLT SOT23 T/R3K	3	3000	.68	3000 †
MMBT918LT1	A SSNPN SOT23 T/R3K	2	3000	.26	3000 †
MMBV105GLT1	A SSDIODE SOT23 T/R3K	1	3000	.46	3000 †
MMBV109LT1	A SSDIO SOT23 TAPE/REEL3K	1	3000	.46	3000 †
MMBV2101LT1	A SSGPDIODE SOT23 T/R3K	2	3000	.46	3000 †
MMBV2105LT1	A SSGPDIODE SOT23 T/R3K	3	3000	1.05	3000 †
MMBV2107LT1	A SSGPDIODE SOT23 T/R3K	3	3000	1.05	3000 †
MMBV2108LT1	A SSGPDIODE SOT23 T/R3K	3	3000	1.05	3000 †
MMBV2109LT1	A SSGPDIODE SOT23 T/R3K	3	3000	1.05	3000 †
MMBV3102LT1	A SSDIODE SOT23 T/R3K	2	3000	.46	3000 †
MMBV3401LT1	A SSDIODE SOT23 T/R3K	1	3000	.46	3000 †
MMBV3700LT1	A SSDIODE SOT23 T/R3K	3	3000	1.56	3000 †
MMBV409LT1	A SSDIODE SOT23 T/R3K	2	3000	.46	3000 †
MMBV432LT1	A SSDIODE SOT-23 T&R3K	2	3000	.70	3000 †
MMBV609LT1	A SSDUAL SOT-23 T/R3K	2	3000	.70	3000 †
MMBV809LT1	A SSDIODE SOT-23 T/R3K	3	3000	1.05	3000 †
MMBZ15VALT1	A ZENCOMMONANODE15V	2	3000	.16	3000 †
MMBZ15VDLT1	A ZENDIO15V COMCATH DUAL	1	3000	.26	3000 †
MMBZ20VALT1	A ZENCOMMONANODE20V	2	3000	.16	3000 †
MMBZ27VCLT1	A ZNR TANSIENT SUPPRESSOR	2	3000	.16	3000 †
MMBZ5V6ALT1	A ZENCOMMONANODE5.6V	N	3000	.24	3000 †
MMBZ5221BLT1	A 2.4V ZENER SOT23	2	3000	.15	3000 †
MMBZ5226BLT1	A SS3.3V5% SOT23 T/R3K	2	3000	.15	3000 †
MMBZ5228BLT1	A SS3.9V5% SOT23 T/R3K	2	3000	.15	3000 †
MMBZ5229BLT1	A SS4.3V5% SOT23 T/R3K	2	3000	.15	3000 †
MMBZ5230BLT1	A SS4.7V5% SOT23 T/R3K	1	3000	.15	3000 †
MMBZ5231BLT1	A SS5.1V5% SOT23 T/R3K	1	3000	.15	3000 †
MMBZ5232BLT1	A SS5.6V5% SOT23 T/R3K	1	3000	.15	3000 †
MMBZ5233BLT1	A SS6.0V5% SOT23 T/R3K	2	3000	.15	3000 †
MMBZ5234BLT1	A SS6.2V5% SOT23 T/R3K	1	3000	.15	3000 †
MMBZ5235BLT1	A SS6.8V5% SOT23 T/R3K	1	3000	.15	3000 †
MMBZ5236BLT1	A SS7.5V5% SOT23 T/R3K	1	3000	.15	3000 †
MMBZ5237BLT1	A SS8.2V5% SOT23 T/R3K	2	3000	.15	3000 †
MMBZ5239BLT1	A SS9.1V5% SOT23 T/R3K	2	3000	.15	3000 †
MMBZ5240BLT1	A SS10V5% SOT23 T/R3K	1	3000	.15	3000 †
MMBZ5241BLT1	A SS11V5% SOT23 T/R3K	2	3000	.15	3000 †
MMBZ5242BLT1	A SS12V5% SOT23 T/R3K	1	3000	.15	3000 †
MMBZ5243BLT1	A SS13V5% SOT23 T/R3K	2	3000	.15	3000 †
MMBZ5244BLT1	A SS14V5% SOT23 T/R3K	2	3000	.15	3000 †
MMBZ5245BLT1	A SS15V5% SOT23 T/R3K	1	3000	.15	3000 †
MMBZ5246BLT1	A SS16V5% SOT23 T/R3K	2	3000	.15	3000 †
MMBZ5248BLT1	A SS18V5% SOT23 T/R3K	2	3000	.15	3000 †

A = OSPD/Power
 B = Analog/Logic
 J = Transportation
 L = Consumer
 N = Networking
 V = Wireless

S = Proprietary Device
 B = Motorola Blue Chip Program Device
 P = Phoenix Program
 * = First Time in Book
 † \$200 Minimum Waived

N = Key New Motorola Device
 R = Key "Focus" Motorola Device

1 = Mature, Stable, High-Volume Device
 2 = Moderate-Volume Device
 3 = Low-Volume Device

COMMERCIAL COMPONENTS

Type No.	Grp/Description	Per Unit Sugg. Factory			
		Resale Price	Price	Order Incrmt	
PC	Qty				
MMBZ5249BLT1	A SS19V5% SOT23 T/R3K	2	3000	.15 3000	†
MMBZ5250BLT1	A SS20V5% SOT23 T/R3K	N	3000	.15 3000	†
MMBZ5251BLT1	A SS22V5% SOT23 T/R3K	2	3000	.15 3000	†
MMBZ5252BLT1	A SS24V5% SOT23 T/R3K	3	3000	.38 3000	†
MMBZ5253BLT1	A SS25V5% SOT23 T/R3K	2	3000	.15 3000	†
MMBZ5254BLT1	A SS27V5% SOT23 T/R3K	2	3000	.15 3000	†
MMBZ5255BLT1	A SS28V5% SOT23 T/R3K	2	3000	.15 3000	†
MMBZ5256BLT1	A SS30V5% SOT23 T/R3K	3	3000	.38 3000	†
MMBZ5257BLT1	A SS33V5% SOT23 T/R3K	2	3000	.15 3000	†
MMBZ5259BLT1	A 39V ZENER SOT23 T/R	2	3000	.15 3000	†
MMBZ6V2ALT1	A ZN, COMMAN, DL MONO6.2V	2	3000	.16 3000	†
MMDF1N05ER2	A TMOS FET DUAL NCHAN	N	2500	.67 2500	†
MMDF2C01HDR2	A DUAL COMPLEMENTARY 12V	N	2500	.72 2500	†
MMDF2C02ER2	A DUAL COMP 20V MOSFET	N	2500	.67 2500	†
MMDF2C02HDR2	A DUAL COMPLEMENTARY 20V	N	2500	.67 2500	†
MMDF2C03HDR2	A DUAL COMPLEMENTARY 30V	N	2500	.72 2500	†
MMDF2N02ER2	A TMOS FET DUAL NCHAN	2	2500	.67 2500	†
MMDF2N05ZR2	A DUAL SO8, HD TMOS, 50V	2	2500	.75 2500	†
MMDF2P01HDR2	A DLP/CHAN 12V, SOIC-08PKG	N	2500	.67 2500	†
MMDF2P02ER2	A DUAL P-CHAN 20V MOSFET	N	2500	.67 2500	†
MMDF2P02HDR2	A TMOS PWR FET 20V, 0.16OHM	N	2500	.72 2500	†
MMDF2P03HDR2	A TMOS PWR FET 30V, 0.22OHM	N	2500	.72 2500	†
MMDF3N02HDR2	A TMOS PWR FET	N	2500	.72 2500	†
MMDF3N03HDR2	A DUAL N-CHAN 30V MOSFET	N	2500	.67 2500	†
MMDF3N04HDR2	A DUAL NCHAN 40V, 3.4A, 80MOM	2	2500	.67 2500	†
MMDF4N01HDR2	A HDTMOS SINGLE N-CHAN	N	2500	.72 2500	†
MMDF5N02ZR2	A TMOS PWR FET, 20V	N	2500	1.00 2500	†
MMDF6N02HDR2	A DUAL N-CH 20V MOSFET	N	2500	1.14 2500	†
MMDF6N03HDR2	A TMOS FET, NCHN	N	2500	1.08 2500	†
MMDJ3P03BJTR2	A PWR BPLR JUNC XSTR, DUAL	N	2500	.76 2500 *	
MMFT1N10ET1	A PWR TMOS NCHAN 100V	N	1000	1.70 1000	†
MMFT1N10ET3	A PWR TMOS NCHAN 100V	N	4000	1.70 4000	†
MMFT107T1	A SS SOT223 TMOS FET T&R1K	2	1000	.85 1000	†
MMFT2N02ELT1	A PWR TMOS NCHAN 20V LL	N	1000	1.02 1000	†
MMFT2406T1	A SPP FET NCHAN	N	1000	.846 1000	†
MMFT2955ET1	A TMOS PWR FET, 60V, 300MICROA	N	1000	1.36 1000	†
MMFT2955ET3	A TMOS PWR FET, 60V, 300MICROA	N	4000	1.36 4000	†
MMFT3055ELT1	A MED PWR LL NCHAN 60V TMOS	1	1000	1.02 1000	†
MMFT3055ELT3	A MED PWR LL NCHAN 60V TMOS	N	4000	1.02 4000	†
MMFT3055ET1	A MED PWR NCHAN 60V TMOS	N	1000	.92 1000	†
MMFT3055ET3	A MED PWR NCHAN 60V TMOS	N	4000	.92 4000	†
MMFT3055VT3	A TMOS V FET, 60V, 0.130 OHM	N	4000	.70 4000	†
MMFT6661T1	A SS SOT223 TMOS FET T&R1K	2	1000	.75 1000	†
MMFT960T1	A SS SOT223 TMOS FET T&R1K	2	1000	.85 1000	†
MMG05N60D	A POWERLUX IGBT (0.5A, 600V)	N	1	.68 1 *	†

Type No.	Grp/Description	Per Unit Sugg. Factory			
		Resale Price	Price	Order Incrmt	
PC	Qty				
MMJT9435T1	A XSTR SOT223 PNP	N	1000	.52 1000 *	
MMJT9435T3	A XSTR SOT223 PNP	N	4000	.52 4000 *	
MMMQ2222	A LAST ORDER DATE: 08/28/98	3	48	3.12 48	†
MMMQ2222A	A SS GP QUAD AMP NPN SO-16	1	48	2.24 48	†
MMMQ2222AR1	A SS SO-16 TAPE/REEL 500	1	500	2.32 500	†
MMMQ2369	A SS GP QUAD AMP NPN SO-16	2	48	3.72 48	†
MMMQ2907	A LAST ORDER DATE: 08/28/98	2	48	4.12 48	†
MMMQ2907A	A SS GP QUAD AMP PNP SO-16	1	48	2.24 48	†
MMMQ2907AR1	A SS SO-16 TAPE/REEL 500	2	500	4.12 500	†
MMMQ3467	A SS QUAD DRIV PNP SO-16	2	48	3.68 48	†
MMMQ3467R2	A LAST ORDER DATE: 08/28/98	3	2500	3.31 2500	†
MMMQ3725	A SS QUAD DRIV NPN SO-16	3	48	5.58 48	†
MMMQ3904	A SS GP QUAD AMP NPN SO-16	2	48	4.72 48	†
MMMQ3904R1	A SS SO-16 TAPE/REEL 500	1	500	2.44 500	†
MMMQ3906	A SS GP QUAD AMP PNP SO-16	2	48	2.36 48	†
MMMQ3906R1	A SS SO-16 TAPE/REEL 500	2	500	2.44 500	†
MMMQ6700	A SS QUAD PAIR PNP/NPN SO16	2	48	2.54 48	†
MMMQ6842	A LAST ORDER DATE: 08/28/98	3	48	7.15 48	†
MMQA20VT1	A ZN COMMAN DUAL QUAD	2	3000	.30 3000	†
MMQA5V6T1	A ZN COMMAN DUAL QUAD	N	3000	.30 3000	†
MMSD1000T1	A MINIBLOC SWIT DIODE	2	3000	.16 3000	†
MMSD103T1	A DIODE SWITCHING	N	3000	.14 3000 *	†
MMSD301T1	A SCHOTTKY BARRIER DIODE	N	3000	.26 3000 *	†
MMSD4148T1	A HI SPEED SWIT DIODE	N	3000	.13 3000 *	†
MMSD701T1	A SCH BAR DI/SOD123	N	3000	.15 3000 *	†
MMSD914T1	A H S SW DI/SOD123	N	3000	.13 3000	†
MMSF10N02ZR2	A SNL CHN 20V, 10A, 40MOHM	N	2500	1.00 2500	†
MMSF2P02ER2	A DUAL P-CHANNEL 20V MOSFET	N	2500	.67 2500	†
MMSF3P02HDR2	A TMOS PWR FET 20V, 0.100HM	N	2500	.72 2500	†
MMSF3P03HDR2	A TMOS PWR 30V, 0.001OHM	2	2500	.72 2500	†
MMSF4P01HDR2	A SGP/CHAN 12V, SOIC-08PKG	N	2500	.72 2500	†
MMSF5N02HDR2	A TMOS PWR 20V, 25 MOHMS	N	2500	.75 2500	†
MMSF5N03HDR2	A TMOS PWR FET 30V, 0.45OHM	N	2500	.71 2500	†
MMSF5P02HDR2	A P-CH, 20V, 8.7A, 30MOHM	N	2500	1.00 2500	†
MMSF7N03HDR2	A TMOS PWR FET, 30V, 25MOHM	2	2500	.71 2500	†
MMSF7N03ZR2	A SNL NCHN 30V, 7.0A, 40MOHM	N	2500	1.00 2500	†
MMSZ10T1	A ZENER REG SOD123 T/R	2	3000	.088 3000	†
MMSZ11T1	A ZENER REG SOD123 T/R	2	3000	.088 3000	†
MMSZ12T1	A ZENER REG SOD123 T/R	2	3000	.088 3000	†
MMSZ13T1	A ZENER REG SOD123 T/R	2	3000	.088 3000	†
MMSZ15T1	A ZENER REG SOD123 T/R	2	3000	.088 3000	†
MMSZ16T1	A ZENER REG SOD123 T/R	2	3000	.088 3000	†
MMSZ2V4T1	A ZEN REG SOD1232.4V	2	3000	.088 3000	†
MMSZ2V7T1	A ZENER REG SOD123 T/R	2	3000	.088 3000	†
MMSZ20T1	A ZENER REG SOD123 T/R	2	3000	.088 3000	†

A = OSPD/Power
 B = Analog/Logic
 J = Transportation
 L = Consumer
 N = Networking
 V = Wireless

S = Proprietary Device
 B = Motorola Blue Chip Program Device
 P = Phoenix Program
 * = First Time in Book
 † \$200 Minimum Waived

N = Key New Motorola Device
 R = Key "Focus" Motorola Device

1 = Mature, Stable, High-Volume Device
 2 = Moderate-Volume Device
 3 = Low-Volume Device

EFFECTIVE DATE: JANUARY 10, 1998

COMMERCIAL COMPONENTS

Type No.	Grp/Description	Per Unit Sugg. Factory			†	Type No.	Grp/Description	Per Unit Sugg. Factory			†		
		PC	Qty	Price				Order	PC	Qty		Price	Order
MMSZ22T1	A ZENER REG SOD123 T/R	2	3000	.088	3000	†	MMSZ5222BT1	A ZEN REG SOD1232.5V	2	3000	.088	3000	†
MMSZ24T1	A ZENER REG SOD123 T/R	2	3000	.088	3000	†	MMSZ5223BT1	A ZEN REG SOD1232.7V	2	3000	.088	3000	†
MMSZ3V0T1	A ZENER REG SOD123 T/R	2	3000	.088	3000	†	MMSZ5224BT1	A ZENER REG SOD123 T/R	2	3000	.088	3000	†
MMSZ3V3T1	A ZENER REG SOD123 T/R	2	3000	.088	3000	†	MMSZ5225BT1	A ZEN REG SOD1233.0V	2	3000	.088	3000	†
MMSZ3V6T1	A ZENER REG SOD123 T/R	2	3000	.088	3000	†	MMSZ5226BT1	A ZENER REG SOD123 T/R	2	3000	.088	3000	†
MMSZ3V9T1	A ZENER REG SOD123 T/R	2	3000	.088	3000	†	MMSZ5227BT1	A ZENER REG SOD123 T/R	2	3000	.088	3000	†
MMSZ39T1	A ZENER REG SOD123 T/R	2	3000	.088	3000	†	MMSZ5228BT1	A ZENER REG SOD123 T/R	2	3000	.088	3000	†
MMSZ4V3T1	A ZENER REG SOD123 T/R	2	3000	.088	3000	†	MMSZ5229BT1	A ZENER REGULATOR SOD123	2	3000	.088	3000	†
MMSZ4V7T1	A ZENER REG SOD123 T/R	2	3000	.088	3000	†	MMSZ5230BT1	A ZEN REG SOD1234.7V	2	3000	.088	3000	†
MMSZ43T1	A ZENER REG SOD123 T/R	2	3000	.088	3000	†	MMSZ5231BT1	A ZEN REG SOD1235.1V	1	3000	.088	3000	†
MMSZ4678T1	A ZEN REG SOD1231.8V	2	3000	.14	3000	†	MMSZ5232BT1	A ZEN REG SOD1235.6V	2	3000	.088	3000	†
MMSZ4679T1	A ZENER REG SOD123 T/R	2	3000	.14	3000	†	MMSZ5233BT1	A ZEN REG SOD1236.0V	2	3000	.088	3000	†
MMSZ4680T1	A ZENER REG SOD123 T/R	2	3000	.14	3000	†	MMSZ5234BT1	A ZEN REG SOD1236.2V	2	3000	.088	3000	†
MMSZ4681T1	A ZENER REG SOD123 T/R	2	3000	.14	3000	†	MMSZ5235BT1	A ZEN REG SOD1236.8V	2	3000	.088	3000	†
MMSZ4683T1	A ZENER REG SOD123 T/R	2	3000	.14	3000	†	MMSZ5235BT3	A ZEN REG SOD1236.8V	2	10000	.088	10000	†
MMSZ4684T1	A ZENER REG SOD123 T/R	2	3000	.14	3000	†	MMSZ5236BT1	A ZENER REG SOD123 T/R	2	3000	.088	3000	†
MMSZ4685T1	A ZENER REG SOD123 T/R	2	3000	.14	3000	†	MMSZ5237BT1	A ZENER REG SOD123 T/R	2	3000	.088	3000	†
MMSZ4686T1	A ZENER REG SOD123 T/R	2	3000	.14	3000	†	MMSZ5238BT1	A ZENER REG SOD123 T/R	2	3000	.088	3000	†
MMSZ4687T1	A ZENER REG SOD123 T/R	2	3000	.14	3000	†	MMSZ5239BT1	A ZEN REG SOD1239.1V	2	3000	.088	3000	†
MMSZ4688T1	A ZENER REG SOD123 T/R	2	3000	.14	3000	†	MMSZ5240BT1	A ZEN REG SOD12310V	2	3000	.088	3000	†
MMSZ4689T1	A ZENER REGULATOR SOD123	2	3000	.14	3000	†	MMSZ5241BT1	A ZENER REG SOD123 T/R	2	3000	.088	3000	†
MMSZ4690T1	A ZENER REG SOD123 T/R	2	3000	.14	3000	†	MMSZ5242BT1	A ZEN REG SOD12312V	2	3000	.088	3000	†
MMSZ4691T1	A ZENER REG SOD123 T/R	2	3000	.14	3000	†	MMSZ5243BT1	A ZENER REG SOD123 T/R	2	3000	.088	3000	†
MMSZ4692T1	A ZENER REG SOD123 T/R	2	3000	.14	3000	†	MMSZ5244BT1	A ZEN REG SOD12314V	2	3000	.088	3000	†
MMSZ4693T1	A ZENER REG SOD123 T/R	2	3000	.14	3000	†	MMSZ5245BT1	A ZEN REG SOD12315V	1	3000	.088	3000	†
MMSZ4694T1	A ZENER REG SOD123 T/R	2	3000	.14	3000	†	MMSZ5245BT3	A ZEN REG SOD12315V	2	10000	.088	10000	†
MMSZ4695T1	A ZENER REG SOD123 T/R	2	3000	.14	3000	†	MMSZ5246BT1	A ZEN REG SOD12316V	2	3000	.088	3000	†
MMSZ4696T1	A ZENER REG SOD123 T/R	2	3000	.14	3000	†	MMSZ5247BT1	A ZENER REG SOD123 T/R	2	3000	.088	3000	†
MMSZ4697T1	A ZENER REG SOD123 T/R	2	3000	.14	3000	†	MMSZ5248BT1	A ZEN REG SOD12318V	2	3000	.088	3000	†
MMSZ4699T1	A ZENER REG SOD123 T/R	2	3000	.14	3000	†	MMSZ5250BT1	A ZENER REG SOD123 T/R	2	3000	.088	3000	†
MMSZ4700T1	A ZENER REG SOD123 T/R	2	3000	.14	3000	†	MMSZ5251BT1	A ZENER REG SOD123 T/R	2	3000	.088	3000	†
MMSZ4701T1	A ZENER REG SOD123 T/R	2	3000	.14	3000	†	MMSZ5252BT1	A ZEN REG SOD12324V	2	3000	.088	3000	†
MMSZ4702T1	A ZENER REG SOD123 T/R	2	3000	.14	3000	†	MMSZ5253BT1	A ZENER REG SOD123 T/R	2	3000	.088	3000	†
MMSZ4703T1	A ZENER REG SOD123 T/R	2	3000	.14	3000	†	MMSZ5254BT1	A ZEN REG SOD12327V	2	3000	.088	3000	†
MMSZ4705T1	A ZENER REG SOD123 T/R	2	3000	.14	3000	†	MMSZ5255BT1	A ZENER REGULATOR SOD123	2	3000	.088	3000	†
MMSZ4707T1	A ZENER REG SOD123 T/R	2	3000	.14	3000	†	MMSZ5256BT1	A ZEN REG SOD12330V	2	3000	.088	3000	†
MMSZ4708T1	A ZENER REG SOD123 T/R	2	3000	.14	3000	†	MMSZ5257BT1	A ZENER REG SOD123 T/R	2	3000	.088	3000	†
MMSZ4709T1	A ZENER REG SOD123 T/R	2	3000	.14	3000	†	MMSZ5258BT1	A ZEN REG SOD12336V	2	3000	.088	3000	†
MMSZ4712T1	A ZENER REG SOD123 T/R	2	3000	.14	3000	†	MMSZ5259BT1	A ZENER REG SOD123 T/R	2	3000	.088	3000	†
MMSZ4715T1	A ZENER REG SOD123 T/R	2	3000	.14	3000	†	MMSZ5260BT1	A ZENER REG SOD123 T/R	2	3000	.088	3000	†
MMSZ4716T1	A ZENER REG SOD123 T/R	2	3000	.14	3000	†	MMSZ5261BT1	A ZEN REG SOD12347V	2	3000	.088	3000	†
MMSZ4717T1	A ZENER REG SOD123 T/R	2	3000	.14	3000	†	MMSZ5262BT1	A ZEN REG SOD12351V	2	3000	.088	3000	†
MMSZ5V1T1	A ZENER REG SOD123 T/R	2	3000	.088	3000	†	MMSZ5263BT1	A ZENER REG SOD123 SAMP	N	3000	.088	3000	†
MMSZ5V6T1	A ZENER REG SOD123 T/R	2	3000	.088	3000	†	MMSZ5265BT1	A ZEN REG SOD12362V	N	3000	.088	3000	†
MMSZ5221BT1	A ZEN REG SOD1232.4V	2	3000	.088	3000	†	MMSZ5266BT1	A ZENER DIODE T/R	N	3000	.088	3000	†

A = OSPD/Power
 B = Analog/Logic
 J = Transportation
 L = Consumer
 N = Networking
 V = Wireless

S = Proprietary Device
 B = Motorola Blue Chip Program Device
 P = Phoenix Program
 ★ = First Time in Book
 † \$200 Minimum Waived

N = Key New Motorola Device
 R = Key "Focus" Motorola Device

1 = Mature, Stable, High-Volume Device
 2 = Moderate-Volume Device
 3 = Low-Volume Device

EFFECTIVE DATE: JANUARY 10, 1998

COMMERCIAL COMPONENTS

Type No.	Grp/Description	Per Unit Sugg. Factory				
		Resale Price	Price	Order		
PC	Qty	Price	Incrrmnt			
MMSZ5267BT1	A ZENREGSOD12375V	N	3000	.088	3000	†
MMSZ5268BT1	A ZENREGSOD12382V	N	3000	.088	3000	†
MMSZ5270BT1	A ZENREGSOD12391V	N	3000	.088	3000	†
MMSZ56T1	A ZENERREGSOD123 T/R	2	3000	.088	3000	†
MMSZ6V2T1	A ZENERREGSOD123 T/R	2	3000	.088	3000	†
MMSZ6V8T1	A ZENERREGSOD123 T/R	2	3000	.088	3000	†
MMSZ7V5T1	A ZENERREGSOD123 T/R	2	3000	.088	3000	†
MMSZ8V2T1	A ZENERREGSOD123 T/R	2	3000	.088	3000	†
MMSZ9V1T1	A ZENERREGSOD123 T/R	2	3000	.088	3000	†
MMT10V275	A THYBI-DIRECTNL SURG SUPP	N	1200	.78	1200	†
MMT10V400	A THYBI-DIRECTNL SURG SUPP	N	1200	.84	1200	†
MMUN2111LT1	A BIASRESISTORXSTRSOT23	2	3000	.12	3000	†
MMUN2113LT1	A LASTORDERDATE:08/28/98	2	3000	.12	3000	†
MMUN2211LT1	A BIASRESISTORXSTRSOT23	2	3000	.12	3000	†
MMUN2212LT1	A BIASRESISTORXSTRSOT23	2	3000	.12	3000	†
MMUN2213LT1	A BIASRESISTORXSTRSOT23	2	3000	.12	3000	†
MM4209	A XSTRSILICON	2	1000	1.80	1000	†
MOCD207	A S08DUALXSTRISOLATOR	N	50	1.22	50	†
MOCD207R2	A S08DUALXSTRISOLATOR TR	2	2500	1.22	2500	†
MOCD208	A S08DUALXSTRISOLATOR	N	50	1.22	50	†
MOCD208R2	A S08DUALXSTRISOLATOR	2	2500	1.22	2500	†
MOCD211	A DUALXSTRISOLATOR	N	50	.86	50	†
MOCD213	A S08DUALXSTRISOLATOR	N	50	1.22	50	†
MOCD213R2	A S08DUALXSTRISOLATOR TR	2	2500	1.22	2500	†
MOCD217	A SMOUTLINE DCHAN OPTOISO	N	50	1.22	50	†
MOCD217R2	A SMOUTLINE DCHAN OPTOISO	2	2500	1.22	2500	†
MOCD223	A S08DUALDARLISOLATOR	N	50	1.38	50	†
MOCD223R2	A S08DUALDARLISOLATOR TR	2	2500	1.44	2500	†
MOCZ500	A OPTOCOUPPLERLN	N	50	1.20	50	†
MOCZ500S	A OPTOCOUPPLERLN	N	50	1.26	50	†
MOCZ500SR2	A OPTOCOUPPLERLN	N	50	1.32	50	†
MOCZ500SR2V	A OPTOCOUPPLERLN	N	50	1.38	50	†
MOCZ500SV	A OPTOCOUPPLERLN	N	50	1.32	50	†
MOCZ500T	A OPTOCOUPPLERLN	N	50	1.26	50	†
MOCZ500TV	A OPTOCOUPPLERLN	N	50	1.32	50	†
MOCZ500V	A OPTOCOUPPLERLN	N	50	1.26	50	†
MOC119	A OPTOISO DARL6-PINDIP	2	50	.96	50	†
MOC119T	A OPTOISO VDE (0.400) LIF	N	50	1.04	50	†
MOC2A40-005	A OPTOCOUPPLER	2	20	4.00	20	†
MOC2A40-010	A OPTOCOUPPLER	1	20	4.00	20	†
MOC2A60-005	A PWR OPTO ISO2 AMP	N	20	4.00	20	†
MOC2A60-010	A PWR OPTO ISO2 AMP	2	20	4.00	20	†
MOC2A60-10F	A OPTO-ISOLATOR	N	20	5.00	20	†
MOC2A60-5C	A PWR OPTO ISO2 AMP	N	20	5.00	20	†
MOC2A60-5F	A OPTO-ISOLATOR	N	20	5.00	20	†

Type No.	Grp/Description	Per Unit Sugg. Factory				
		Resale Price	Price	Order		
PC	Qty	Price	Incrrmnt			
MOC2R60-010	A PWR OPTO-ISOLATOR	N	20	5.00	20	†
MOC2R60-015	A PWR OPTO-ISOLATOR	N	20	5.00	20	†
MOC2R60-10C	A PWR OPTO-ISOLATOR	N	20	5.00	20	†
MOC2R60-10CV	A PWR OPTO-ISOLATOR	N	20	5.00	20	†
MOC2R60-10F	A PWR OPTO-ISOLATOR	N	20	5.00	20	†
MOC2R60-10FV	A PWR OPTO-ISOLATOR	N	20	5.00	20	†
MOC205	A OPTOISO XSTR SO-8	2	50	.78	50	†
MOC205R1	A OPTOISO XSTR SO-8 T/R	2	500	.90	500	†
MOC205R2	A OPTOISO XSTR SO-8 T/R	2	2500	.90	2500	†
MOC206	A OPTOISO XSTR SO-8	2	50	.78	50	†
MOC206R1	A OPTOISO XSTR SO-8 T/R	2	500	.78	500	†
MOC206R2	A OPTOISO XSTR SO-8 T/R	N	2500	.78	2500	†
MOC207	A OPTOISO XSTR SO-8	2	50	.80	50	†
MOC207R1	A OPTOISO XSTR SO-8 T/R	2	500	.92	500	†
MOC207R2	A OPTOISO XSTR SO-8 T/R	2	2500	.92	2500	†
MOC211	A OPTOISO XSTR SO-8	2	50	.78	50	†
MOC211R1	A OPTOISO XSTR SO-8 T/R	2	500	.90	500	†
MOC211R2	A OPTOISO XSTR SO-8 T/R	2	2500	.82	2500	†
MOC212	A OPTOISO XSTR SO-8	N	50	.78	50	†
MOC212R1	A OPTOISO XSTR SO-8 T/R	2	500	.78	500	†
MOC212R2	A OPTOISO XSTR SO-8 T/R	2	2500	.82	2500	†
MOC213	A OPTOISO XSTR SO-8	2	50	.78	50	†
MOC213R1	A OPTOISO XSTR SO-8 T/R	3	500	1.56	500	†
MOC213R2	A OPTOISO XSTR SO-8 T/R	2	2500	.86	2500	†
MOC215	A OPTOISO XSTR SO-8	N	50	.90	50	†
MOC215R1	A OPTOISO XSTR SO-8 T/R	2	500	.90	500	†
MOC215R2	A OPTOISO XSTR SO-8 T/R	N	2500	.90	2500	†
MOC216	A OPTOISO XSTR SO-8	N	50	.78	50	†
MOC216R1	A OPTOISO XSTR SO-8 T/R	2	500	.78	500	†
MOC217	A OPTOISO XSTR SO-8	2	50	.80	50	†
MOC217R1	A OPTOISO XSTR SO-8 T/R	2	500	.92	500	†
MOC217R2	A OPTOISO XSTR SO-8 T/R	2	2500	.92	2500	†
MOC223	A OPTOISO DARL SO-8	2	50	.86	50	†
MOC223R1	A OPTOISO DARL SO-8 T/R	2	500	.86	500	†
MOC223R2	A OPTOISO DARL SO-8 T/R	2	2500	.86	2500	†
MOC256	A S08 AC INPUT XSTR OPTO	N	50	.92	50	†
MOC256R2	A S08 AC INPUT XSTR OPTO	2	2500	.92	2500	†
MOC3010	A OPTOISO TRIAC6-PIN DIP	1	50	.70	50	†
MOC3011	A OPTOISO TRIAC6-PIN DIP	1	50	.70	50	†
MOC3011S	A OPTOISO TRIAC SURF MOUNT	N	50	1.36	50	†
MOC3012	A OPTOISO TRIAC6-PIN DIP	1	50	.70	50	†
MOC3012S	A OPTOISO TRIAC SURF MOUNT	2	50	.80	50	†
MOC3020	A OPTOISO TRIAC6-PIN DIP	2	50	.72	50	†
MOC3021	A OPTOISO TRIAC6-PIN DIP	1	50	.74	50	†
MOC3022	A OPTOISO TRIAC6-PIN DIP	1	50	.76	50	†

A = OSPD/Power
 B = Analog/Logic
 J = Transportation
 L = Consumer
 N = Networking
 V = Wireless

S = Proprietary Device
 B = Motorola Blue Chip Program Device
 P = Phoenix Program
 * = First Time in Book
 † = \$200 Minimum Waived

N = Key New Motorola Device
 R = Key "Focus" Motorola Device

1 = Mature, Stable, High-Volume Device
 2 = Moderate-Volume Device
 3 = Low-Volume Device

EFFECTIVE DATE: JANUARY 10, 1998

COMMERCIAL COMPONENTS

Type No.	Grp/Description	Per Unit Sugg. Factory				Type No.	Grp/Description	Per Unit Sugg. Factory					
		PC	Qty	Price	Order			PC	Qty	Price	Order		
MOC3022S	A OPTOISO TRIAC SURF MOUNT	N	50	.84	50	†	MOC5007	A 6-PIN SCHMIT TRIGGER OPTO	2	50	2.00	50	†
MOC3022SR2	A OPTOISO TRIAC S/M T/R	2	1000	1.00	1000	†	MOC5008	A 6-PIN SCHMIT TRIGGER OPTO	2	50	1.42	50	†
MOC3022V	A OPTOISOLATOR 6-PIN DIP	N	50	1.00	50	†	MOC5009	A 6-PIN SCHMIT TRIGGER OPTO	2	50	1.42	50	†
MOC3023	A OPTOISO TRIAC 6-PIN DIP	1	50	.78	50	†	MOC8020	A OPTOISO DARL 6-PIN DIP	2	50	1.20	50	†
MOC3023S	A OPTOISO TRIAC SURF MOUNT	N	50	.86	50	†	MOC8020SR2	A OPTOISO DARL 6-PIN DIP	2	1000	1.20	1000	†
MOC3023SR2	A OPTOISO TRIAC S/M T/R	2	1000	1.02	1000	†	MOC8021	A OPTOISO DARL 6-PIN DIP	1	50	1.20	50	†
MOC3023SR2V	A OPTOISO SURF MOUNT T/R	2	1000	1.02	1000	†	MOC8030	A OPTOISO DARL 6-PIN DIP	2	50	1.20	50	†
MOC3023T	A OPTOISO VDE (0.400) L/F	N	50	1.02	50	†	MOC8030S	A OPTOISO DARL SURF MOUNT	N	50	1.20	50	†
MOC3023TV	A OPTOISO VDE (0.400) L/F	N	50	1.02	50	†	MOC8050	A OPTOISO DARL 6-PIN DIP	1	50	1.20	50	†
MOC3031	A OPTOISO TRIAC 6-PIN DIP	1	50	1.26	50	†	MOC8050S	A OPTOISO DARL SURF MOUNT	N	50	1.20	50	†
MOC3032	A OPTOISO TRIAC 6-PIN DIP	1	50	1.30	50	†	MOC8050SR2	A OPTOELECTRONIC-COUPLER	2	1000	1.20	1000	†
MOC3033	A OPTOISO TRIAC 6-PIN DIP	2	50	1.34	50	†	MOC8050T	A OPTO-ELECTRONIC COUPLER	N	50	1.20	50	†
MOC3041	A OPTOISO TRIAC 6-PIN DIP	1	50	1.38	50	†	MOC8050TV	A OPTO-ELECTRONIC COUPLER	N	50	1.20	50	†
MOC3041T	A OPTOISO VDE (0.400) L/F	N	50	1.50	50	†	MOC8050V	A OPTOELECTRONIC-COUPLER	N	50	1.20	50	†
MOC3042	A OPTOISO TRIAC 6-PIN DIP	1	50	1.42	50	†	MOC8080	A OPTOISO DARL 6-PIN DIP	2	50	1.80	50	†
MOC3043	A OPTOISO TRIAC 6-PIN DIP	1	50	1.46	50	†	MOC8100	A OPTOISO XTR 6-PIN DIP	2	50	1.00	50	†
MOC3043T	A OPTO TRIAC 6-PIN DIP	N	50	1.96	50	†	MOC8106	A OPTOISOLATOR XSTR OUTPUT	N	50	.78	50	†
MOC3051	A OPTOCOUPLER PNP	N	50	1.06	50	†	MOC8106SR2	A OPTOISOLATOR XSTR OUTPUT	N	1000	.88	1000	†
MOC3052	A OPTOCOUPLER PNP	N	50	1.06	50	†	MOC8106TV	A OPTOISOLATOR XSTR OUTPUT	N	50	.84	50	†
MOC3052T	A OPTOCOUPLER PNP	N	50	1.16	50	†	MOC8107	A OPTOISOLATOR XSTR OUTPUT	N	50	.78	50	†
MOC3052TV	A OPTOCOUPLER PNP	N	50	1.16	50	†	MOC8107TV	A OPTOISOLATOR XSTR OUTPUT	N	50	.84	50	†
MOC3052V	A OPTOCOUPLER PNP	N	50	1.16	50	†	MOC8108	A OPTOISOLATOR XSTR OUTPUT	N	50	.78	50	†
MOC3061	A OPTOISO TRIAC 6-PIN DIP	1	50	1.72	50	†	MOC8111	A OPTOISO XTR 6-PIN DIP	2	50	.76	50	†
MOC3061T	A OPTOISO VDE (0.400) L/F	N	50	1.82	50	†	MOC8111T	A OPTOISO VDE (0.400) L/F	N	50	.86	50	†
MOC3062	A OPTOISO TRIAC 6-PIN DIP	1	50	1.68	50	†	MOC8111V	A OPTOISO XTR 6-PIN DIP	N	50	.86	50	†
MOC3063	A OPTOISO TRIAC 6-PIN DIP	1	50	1.76	50	†	MOC8112	A OPTOISO XTR 6-PIN DIP	2	50	.76	50	†
MOC3063S	A OPTOISO TRIAC SURF MOUNT	N	50	1.88	50	†	MOC8112TV	A OPTOCOUPLER	N	50	.86	50	†
MOC3063SR2	A OPTOISO TRIAC S/M T/R	2	1000	2.00	1000	†	MOC8112V	A OPTOCOUPLER	N	50	.86	50	†
MOC3063SV	A OPTOISO TRIAC 6-PIN DIP	N	50	2.00	50	†	MOC8113	A OPTOISO XTR 6-PIN DIP	2	50	.86	50	†
MOC3063T	A OPTOISOLATOR	N	50	1.88	50	†	MOC8204	A OPTOISO HVOLT 6-PIN	2	50	2.26	50	†
MOC3063TV	A OPTOISOLATOR	N	50	1.88	50	†	MPAA3BRD	B ANALOG DEMO BOARD	N	1	1450.00	1 * S	B
MOC3063V	A OPTOISO TRIAC 6-PIN DIP	N	50	1.88	50	†	MPAA3DS	B ANALOG DESIGN SYSTEM	N	1	1052.60	1 * S	B
MOC3081	A OPTOISO TRIAC 6-PIN DIP	2	50	2.16	50	†	MPA1/BRD	B DEMONSTRATION BOARD	N	1	145.00	1	S B
MOC3082	A OPTOISO TRIAC 6-PIN DIP	2	50	2.16	50	†	MPA1/POD	B DOWNLOAD CABLE PC/WRKSTAN	N	1	195.00	1	S B
MOC3083	A OPTOISO TRIAC 6-PIN DIP	2	50	2.38	50	†	MPA1CD/P	B PC CD ONLY	N	1	12.95	1	S B
MOC3083T	A OPTOISO VDE (0.400) L/F	N	50	2.46	50	†	MPA1CD/W	B WORKSTATION CD ONLY	N	1	295.00	1	S B
MOC3083TV	A OPTOISO VDE (0.400) L/F	N	50	2.46	50	†	MPA1E/P	B ENTRY LEVEL SYSTEM PC	N	1	295.00	1	S B
MOC3162	A OPTOISO TRIAC DRIVER OUT	N	50	1.60	50	†	MPA1E/W	B ENTRY LEVEL WORKSTATION	N	1	595.00	1	S B
MOC3162T	A OPTOISO TRIAC DRIVER OUT	N	50	1.66	50	†	MPA1M12/P	B MAINTENANCE FOR PC	N	1	595.00	1	S
MOC3163	A OPTOISO TRIAC DRIVER OUT	N	50	1.68	50	†	MPA1M12/W	B MAINTENANCE FR WORKSTATION	N	1	795.00	1	S
MOC3163S	A OPTOISO TRIAC DRIVER OUT	N	50	1.74	50	†	MPA1S/P	B STANDARD SY. PC	N	1	2295.00	1	S B
MOC3163SR2	A OPTOISO TRIAC DRIVER OUT	2	1000	2.30	1000	†	MPA1S/W	B MPADES SYSTEMS STD	N	1	3995.00	1	S B
MOC3163SV	A OPTOISO TRIAC DRIVER OUT	N	50	1.90	50	†	MPA1WV/BSC	B WKVW OFF SCHEM ENT TOOL	N	1	749.00	1	S
MOC3163T	A OPTOISO TRIAC DRIVER OUT	N	50	1.90	50	†	MPA1WV/BSCPL	B WKVW OFF SCHEM ENT SIM	N	1	1049.00	1	S
MOC3163TV	A OPTOISO TRIAC DRIVER OUT	N	50	1.90	50	†	MPA1WV/DLX	B SCHEM ENT RY SIMULATION	N	1	5149.00	1	S

A = OSPD/Power
 B = Analog/Logic
 J = Transportation
 L = Consumer
 N = Networking
 V = Wireless

S = Proprietary Device
 B = Motorola Blue Chip Program Device
 P = Phoenix Program
 * = First Time in Book
 † = \$200 Minimum Waived

N = Key New Motorola Device
 R = Key "Focus" Motorola Device

1 = Mature, Stable, High-Volume Device
 2 = Moderate-Volume Device
 3 = Low-Volume Device

EFFECTIVE DATE: JANUARY 10, 1998

COMMERCIAL COMPONENTS

Type No.	Grp/Description	Per PC	Unit Qty	Sugg. Resale Price	Factory Order Incrmnt
MPA1WV/STD	B SCHEMENT SMALL MPA PRD	N	1	3149.00	1 S
MPA1WVM/BSC	B WORKVIEWFRMPA1EL/BSC	N	1	199.00	1 S
MPA1WVM/BSCPL	B WORKVIEWFORMPA1EL/BSCPL	N	1	249.00	1 S
MPA1WVM/DLX	B ADDMANTNCE WRK VW OFFICE	N	1	649.00	1 S
MPA1WVM/STD	B ADDYEAR MAINTNCE F WV/OF	N	1	399.00	1 S
MPA1016DD	B FIELD PROG GATE ARRAY	N	24	13.49	24 B
MPA1016DD-004	B FILED PROG GATE ARRAY	N	24	8.37	24 *
MPA1016DD-006	B FILED PROG GATE ARRAY	N	24	6.44	24 *
MPA1016DD-4I	B FILED PROG GATE ARRAY	N	24	9.21	24 *
MPA1016DD-6I	B FILED PROG GATE ARRAY	N	24	7.08	24 *
MPA1016FN-004	B FIELD PROG GATE ARRAY	N	15	7.40	15 *
MPA1016FN-006	B FIELD PROG GATE ARRAY	N	15	5.71	15 *
MPA1016FN-4I	B FILED PROG GATE ARRAY	N	24	8.14	24 *
MPA1016FN-6I	B FILED PROG GATE ARRAY	N	24	6.27	24 *
MPA1036DD-004	B FIELD PROG. GATE ARRAY	N	24	13.59	24 *
MPA1036DD-006	B FIELD PROG. GATE ARRAY	N	24	10.86	24 *
MPA1036DD-4I	B FIELD PROG. GATE ARRAY	N	24	14.95	24 *
MPA1036DD-6I	B FIELD PROG. GATE ARRAY	N	24	11.95	24 *
MPA1036DH-004	B FIELD PROG. GATE ARRAY	N	24	14.03	24 *
MPA1036DH-006	B FIELD PROG. GATE ARRAY	N	24	11.21	24 *
MPA1036DH-4I	B FIELD PROG. GATE ARRAY	N	24	15.43	24 *
MPA1036DH-6I	B FIELD PROG. GATE ARRAY	N	24	12.34	24 *
MPA1036FN-004	B FIELD PROG. GATE ARRAY	N	15	12.59	15 *
MPA1036FN-006	B FIELD PROG. GATE ARRAY	N	15	10.06	15 *
MPA1036FN-4I	B FIELD PROG. GATE ARRAY	N	15	13.85	15 *
MPA1036FN-6I	B FIELD PROG. GATE ARRAY	N	15	11.07	15 *
MPA1064BG-2I	B FIELD PROG GATE ARRAY	N	1	32.90	1 *
MPA1064BG-4I	B FIELD PROG GATE ARRAY	N	1	27.89	1 *
MPA1064BG-6I	B FIELD PROG GATE ARRAY	N	1	22.88	1 *
MPA1064DH-002	B FIELD PROG GATE ARRAY	N	24	23.65	24 *
MPA1064DH-004	B FIELD PROG GATE ARRAY	N	24	19.90	24 *
MPA1064DH-006	B FIELD PROG GATE ARRAY	N	24	16.97	24 *
MPA1064DH-2I	B FIELD PROG GATE ARRAY	N	24	26.02	24 *
MPA1064DH-4I	B FIELD PROG GATE ARRAY	N	24	21.89	24 *
MPA1064DH-6I	B FIELD PROG GATE ARRAY	N	24	18.66	24 *
MPA1064DK-002	B FIELD PROG GATE ARRAY	N	24	26.03	24 *
MPA1064DK-004	B FIELD PROG GATE ARRAY	N	24	22.05	24 *
MPA1064DK-006	B FIELD PROG GATE ARRAY	N	24	17.34	24 *
MPA1064DK-2I	B FIELD PROG GATE ARRAY	N	24	28.63	24 *
MPA1064DK-4I	B FIELD PROG GATE ARRAY	N	24	24.26	24 *
MPA1064DK-6I	B FIELD PROG GATE ARRAY	N	24	19.07	24 *
MPA1100BG-002	B FIELD PROGRAM GATE ARRAY	N	1	436.04	1 * B
MPA1100BG-2I	B FIELD PROGRAM GATE ARRAY	N	1	479.64	1 * B
MPA1100BG-4I	B FIELD PROGRAM GATE ARRAY	N	1	406.50	1 * B
MPA1100BG-6I	B FIELD PROGRAM GATE ARRAY	N	1	335.92	1 * B

Type No.	Grp/Description	Per PC	Unit Qty	Sugg. Resale Price	Factory Order Incrmnt
MPA1100DK-002	B FIELD PROGRAM GATE ARRAY	N	1	77.56	1 *
MPA1100DK-004	B FIELD PROGRAM GATE ARRAY	N	1	64.13	1 * B
MPA1100DK-006	B FIELD PROGRAM GATE ARRAY	N	1	51.30	1 * B
MPA1100DK-2I	B FIELD PROGRAM GATE ARRAY	N	1	85.31	1 *
MPA1100DK-4I	B FIELD PROGRAM GATE ARRAY	N	1	70.55	1 *
MPA1100DK-6I	B FIELD PROGRAM GATE ARRAY	N	1	56.43	1 *
MPA17128D	B 128K SERIAL EPROM	N	96	7.35	96
MPA17128D-I	B EEPROM	N	96	7.72	96
MPA17128FN	B 128K SERIAL EPROM	N	46	7.35	46
MPA17128FN-I	B EEPROM	N	96	7.35	96
MPA17128P	B 128K SERIAL EPROM	N	50	7.35	50
MPA17128P-I	B EEPROM	N	50	7.35	50
MPA1765D	B 64K SERIAL EPROM	N	96	3.75	96
MPA1765D-I	B 64K SERIAL EPROM	N	96	4.13	96 *
MPA1765FN	B 64K SERIAL EPROM	N	46	3.75	46
MPA1765FN-I	B 64K SERIAL EPROM	N	46	4.13	46 *
MPA1765P	B 64K SERIAL EPROM	N	50	3.75	50
MPA1765P-I	B 64K SERIAL EPROM	N	50	4.13	50 *
MPCC5SCMDBBX11	J C PKG & DEBUGGER	N	1	7500.00	1 S
MPCC5SCMDBBX11	J C PKG & DEBUGGER	N	1	7500.00	1 S
MPCC5SCMDBFBX11	J C PKG & DEBUGGER	N	1	7500.00	1 S
MPCC5SCMDBHDX20	L MCTG DEV TOOLS	N	1	4000.00	1 S
MPC2604GAZP66	N 32KX36L2 CACHE/POWER PC	N	44	66.00	44 S
MPC27T415TQ10	N LAST ORDER DATE:11/18/98	N	90	21.38	90
MPC27T415TQ10R	N LAST ORDER DATE:11/18/98	2	700	21.38	700
MPC27T415TQ9	N LAST ORDER DATE:11/18/98	N	90	22.50	90
MPC27T416TQ10	N LAST ORDER DATE:11/18/98	N	90	21.38	90 S
MPC27T416TQ10R	N LAST ORDER DATE:11/18/98	2	700	21.38	700 S
MPC27T416TQ9	N LAST ORDER DATE:11/18/98	N	90	22.50	90 S
MPC27T416TQ9R	N LAST ORDER DATE:11/18/98	2	700	22.50	700 S
MPC505EVB	J AMCU-EVB FORMPC505	N	1	975.00	1 S
MPC821ADI-PC	V ADIFOR PC	N	1	350.00	1
MPC821ADI-SUN4	V ADIFOR SUN4	N	1	350.00	1
MPC821ADS	V 821 EVAL. BOARD	N	1	2645.00	1
MPC821ADS-PC	V 821 ADS & ADIFOR PC	N	1	2995.00	1
MPC821ADS-SUN4	V 821 ADS & ADIFOR SUN4	N	1	2995.00	1
MPC850FADS	N 850 FAMILY DEV. SYSTEM	N	1	2645.00	1 * S
MPC860ADI-PC	N ADIFOR PC	N	1	350.00	1 S
MPC860ADI-SUN4	N ADIFOR SUN4	N	1	350.00	1 S
MPC860ADS	N 860 EVAL. BOARD	N	1	2645.00	1 S
MPC860ADS-PC	N 860 ADS & ADIFOR PC	N	1	2995.00	1 S
MPC860ADS-SUN4	N 860 ADS & ADIFOR SUN4	N	1	2995.00	1 S
MPC860FADS	N MPC860 FAMILY DEV SYSTEM	N	1	2645.00	1 * S
MPC860SR-PHY	N MPC860SR ADS PHY MODULE	N	1	1195.00	1 * S
MPC860SRFADS	N MPC860T FAMILY DEV SYSTEM	N	1	2645.00	1 * S

A = OSPD/Power
 B = Analog/Logic
 J = Transportation
 L = Consumer
 N = Networking
 V = Wireless

S = Proprietary Device
 B = Motorola Blue Chip Program Device
 P = Phoenix Program
 * = First Time in Book
 † = \$200 Minimum Waived

N = Key New Motorola Device
 R = Key "Focus" Motorola Device

1 = Mature, Stable, High-Volume Device
 2 = Moderate-Volume Device
 3 = Low-Volume Device

COMMERCIAL COMPONENTS

Type No.	Grp/Description	Per PC	Unit Qty	Sugg- Resale Price	Factory Order Incrmnt	Type No.	Grp/Description	Per PC	Unit Qty	Sugg- Resale Price	Factory Order Incrmnt		
MPC860TFADS	N MPC860T FAMILY DEV SYSTEM	N	1	2645.00	1 *S	MPIC2112P	A HVHS POWER DRIVER	N	25	2.58	25	†	
MPC903D	L LOWVOLT CLOCK DISTRIB	N	48	2.19	48 B	MPIC2113DW	A HVHS POWER DRIVER	N	45	4.80	45	†	
MPC903DR2	L CLOCK GENERATOR BUFFER	2	2500	1.95	2500 B	MPIC2113P	A HVHS POWER DRIVER	N	25	4.60	25	†	
MPC904D	L CLOCK GENERATOR BUFFER	N	48	2.19	48 B	MPIC2117D	A HVHS POWER DRIVER	N	95	2.80	95	†	
MPC904DR2	L CLOCK GENERATOR BUFFER	2	2500	1.95	2500 B	MPIC2117P	A HVHS POWER DRIVER	N	50	2.60	50	†	
MPC905D	L CLOCK DRIVER	N	48	2.19	48 B	MPIC2130FN	A 3-PHASE BRIDGE DRIVER	N	27	11.50	27	†	
MPC905DR2	L CLOCK DRIVER	2	2500	1.95	2500 B	MPIC2130P	A 3-PHASE BRIDGE DRIVER	N	13	11.12	13	†	
MPC911FN	L LOWVOLT CLOCK DRIVER	N	37	26.66	37 B	MPIC2131FN	A 3-SIDE HIGH/LOW DRIVER	N	27	11.00	27	†	
MPC930FA	L LOWVOLT CLOCK DR.PLL	N	250	14.78	250 S P	MPIC2131P	A HVHS POWER DRIVER	N	13	11.12	13	†	
MPC930FAR2	L LOWVOLT CLOCK DRIVER	2	2000	12.20	2000 S P	MPIC2151D	A HVHS POWER DRIVER	N	95	2.80	95	†	
MPC931FA	L LOWVOLTAGE CLOCK DRIVER	N	250	15.44	250 S P	MPIC2151P	A HVHS POWER DRIVER	N	50	2.60	50	†	
MPC931FAR2	L LOWVOLT CLOCK DRIVER	2	2000	12.94	2000 S P	MPN3404	A SSPIN SWITCH DIODE TO-92	2	1000	.42	1000	†	
MPC947FA	L LOWVOLT CLOCK DRIVER	N	250	14.25	250 S P	MPN3700	A SSPIN SWITCH DIODE TO-92	2	1000	.78	1000	†	
MPC947FAR2	L LOWVOLT CLOCK DRIVER	2	2000	8.28	2000 S P	MPPC5SCCOMDBX11	J SOFTWARE	N	1	4500.00	1 S		
MPC948FA	L LOWVOLT CLOCK DRIVER	N	250	15.00	250 S P	MPPC5SCCOMBEX11	J SOFTWARE	N	1	4500.00	1 S		
MPC948FAR2	L LOWVOLT CLOCK DRIVER	2	2000	13.80	2000 S P	MPPC5SCCOMFBX11	J SOTWARE	N	1	4500.00	1 S		
MPC950FA	L LOWVOLT CLOCK DR.PLL	N	250	20.40	250 S P	MPPC5SCCOMHDX20	L MCTG DEV TOOLS	N	1	2500.00	1 S		
MPC950FAR2	L LOWVOLT CLOCK DRIVER	2	2000	20.35	2000 S P	MPPC5SDEBGDBX11	J AMCU SOFTWARE DEBUGGER	N	1	3600.00	1 S		
MPC951FA	L LOWVOLTAGE CLOCK DRIVER	N	250	20.40	250	MPPC5SDEBGBX11	J AMCU SOFTWARE DEBUGGER	N	1	3600.00	1 S		
MPC952FA	L LOWVOLT CLOCK DRIVER PLL	N	250	20.40	250 S P	MPPC5SDEBGF11	J AMCU SOFTWARE DEBUGGER	N	1	3600.00	1 S		
MPC952FAR2	L LOWVOLT CLOCK DRIVER	2	2000	20.35	2000 S P	MPPC5SDEBGHDX20	L MCTG DEV TOOLS	N	1	2000.00	1 S		
MPC955FAR2	L LAST ORDER DATE:02/11/98	2	2000	11.24	2000 B	MPPC5SRTEKDBX11	J OPERATING SYSTEM	N	1	4800.00	1 *S		
MPC956FAR2	L LAST ORDER DATE:02/11/98	2	2000	11.24	2000 B	MPPC8SRTEKBX12	J AMCU	N	1	4000.00	1 *S		
MPC970FA	L LOWVOLT CLOCK DR.PLL	N	160	17.00	160 B	MPQ2222	A SSQUAD GEN PUR NPN	1	25	1.50	25	†	
MPC970FAR2	L LOWVOLT CLOCK DRIVER	2	1500	14.49	1500 B	MPQ2222A	A SSQUAD GEN PUR NPN	1	25	1.60	25	†	
MPC974FA	L LOWVOLT CLOCK DRIVER	N	160	19.17	160 S P	MPQ2369	A SSQUAD SWITCH NPN	2	25	1.62	25	†	
MPC980FA	L LOWVOLT CLOCK DRIVER PLL	N	160	15.42	160 S P	MPQ2483	A SSQUAD AMP NPN	3	25	3.31	25	†	
MPC990FA	L LOWVOLT CLOCK DRIVER PLL	N	160	31.13	160 S P	MPQ2484	A SSQUAD AMP NPN	2	25	4.12	25	†	
MPC991FA	L LOWVOLT CLOCK DRIVER PLL	N	160	32.08	160 S P	MPQ2906	A LAST ORDER DATE:08/28/98	2	25	3.24	25	†	
MPC992FA	L LOWVOLT CLOCK DRIVER	N	250	31.95	250 S P	MPQ2907	A SSQUAD GEN PUR PNP	1	25	1.50	25	†	
MPF102	A SSJFET N-CHAN T0-92	1	1000	.32	1000	†	MPQ2907A	A SSQUAD GEN PUR PNP	1	25	1.60	25	†
MPF4391	A LAST ORDER DATE:06/26/98	3	1000	1.40	1000	†	MPQ3467	A SSQUAD MEM DRIV PNP	2	25	1.60	25	†
MPF4392	A SSJFET N-CHAN T0-92	2	1000	.70	1000	†	MPQ3725	A SSQUAD COR DRIV NPN	2	25	1.60	25	†
MPF4859	A LAST ORDER DATE:06/26/98	3	1000	4.58	1000	†	MPQ3762	A SSQUAD MEM DRIV PNP	2	25	1.96	25	†
MPF4861A	A LAST ORDER DATE:06/26/98	3	1000	1.92	1000	†	MPQ3798	A SSQUAD AMP PNP S014	3	25	3.31	25	†
MPF6659	A SSTMOS N-CHAN T0-92+	2	1000	.90	1000	†	MPQ3799	A SSQUAD AMP PNP	2	25	2.06	25	†
MPF6660	A SSTMOS N-CHAN T0-92+	2	1000	.90	1000	†	MPQ3904	A SSQUAD AMP NPN	1	25	1.70	25	†
MPF6661	A SSTMOS N-CHAN T0-92+	2	1000	.90	1000	†	MPQ3906	A SSQUAD AMP PNP	2	25	1.70	25	†
MPF910	A TMOSPWR MOSFET PLASTIC	2	1000	.90	1000	†	MPQ6002	A SSQUAD GPPNP/NPN	2	25	2.32	25	†
MPF960	A SSTMOS N-CHAN T0-92	1	1000	.90	1000	†	MPQ6100A	A SSQUAD GP NPN/PNP	2	25	5.30	25	†
MPF971	A LAST ORDER DATE:06/26/98	3	1000	1.86	1000	†	MPQ6426	A SSQUAD DARLING NPN	3	25	3.12	25	†
MPF990	A SSTMOS N-CHAN T0-92	3	1000	1.80	1000	†	MPQ6502	A SSQUAD GP PNP/NPN	2	25	1.60	25	†
MPIC2111D	A HVHS POWER DRIVER	N	95	3.00	95	†	MPQ6600A1	A SSQUAD GPPNP/NPN	3	25	2.83	25	†
MPIC2111P	A HVHS POWER DRIVER	N	50	2.76	50	†	MPQ6700	A SSQUAD GPPNP/NPN	2	25	1.98	25	†
MPIC2112DW	A HVHS POWER DRIVER	N	45	3.00	45	†	MPQ7042	A LAST ORDER DATE:08/28/98	3	25	6.67	25	†

A = OSPD/Power
 B = Analog/Logic
 J = Transportation
 L = Consumer
 N = Networking
 V = Wireless

S = Proprietary Device
 B = Motorola Blue Chip Program Device
 P = Phoenix Program
 * = First Time in Book
 † = \$200 Minimum Waived

N = Key New Motorola Device
 R = Key "Focus" Motorola Device

1 = Mature, Stable, High-Volume Device
 2 = Moderate-Volume Device
 3 = Low-Volume Device

EFFECTIVE DATE: JANUARY 10, 1998

COMMERCIAL COMPONENTS

Type No.	Grp/Description	Per Unit Sugg.		Factory Order	Incrmnt	
		Resale Price	Price			
MPQ7043	A QUAD AMP NPN PLASDIP	2	25	2.90	25	†
MPQ7051	A SS QUAD GP PNP/NPN	3	25	3.58	25	†
MPSA05	A SS GEN PUR NPN TO92	1	5000	.10	5000	†
MPSA05RLRA	A SS NPN TO92 TAPE/REEL2K	2	2000	.10	2000	†
MPSA05RLRM	A SS GP NPN TO92 AMMOPK	N	2000	.10	2000	†
MPSA06	A SS GEN PUR NPN TO92	1	5000	.086	5000	†
MPSA06RLRA	A SS NPN TO92 TAPE/REEL2K	1	2000	.086	2000	†
MPSA06RLRM	A AMMO PACK FOR MPSA06	N	2000	.086	2000	†
MPSA06RLRP	A AMMO PACK FOR MPSA06	N	2000	.086	2000	†
MPSA06RL1	A XSTR SIL NPN	2	2000	.086	2000	†
MPSA12	A SS DARLINGTON NPN TO92	2	5000	.16	5000	†
MPSA12RLRA	A REEL PACK FOR MPSA12	2	2000	.16	2000	†
MPSA13	A SS DARLINGTON NPN TO92	1	5000	.12	5000	†
MPSA13RLRA	A SS NPN TO92 TAPE/REEL2K	3	2000	.40	2000	†
MPSA13RLRP	A REEL PACK FOR MPSA13	N	2000	.12	2000	†
MPSA14	A SS DARLINGTON NPN TO92	1	5000	.12	5000	†
MPSA14RLRA	A SS NPN TO92 TAPE/REEL2K	3	2000	.45	2000	†
MPSA17	A SS SWITCHING NPN TO92	2	5000	1.00	5000	†
MPSA18	A SS LOW NOISE NPN TO92	1	5000	.19	5000	†
MPSA18RLRA	A REEL PK FOR MPSA18	2	2000	.19	2000	†
MPSA20	A SS AMPLIFIER NPN TO92	2	5000	.07	5000	†
MPSA25	A SS DARLINGTON NPN TO92	2	5000	.50	5000	†
MPSA27	A SS DARLINGTON NPN TO92	2	5000	.70	5000	†
MPSA27RLRA	A REEL PACK FOR MPSA27	2	2000	.70	2000	†
MPSA27RLRM	A DARLINGTON NPN TO92	2	2000	.70	2000	†
MPSA28	A SS DARLINGTON NPN TO92	2	5000	.52	5000	†
MPSA28RLRP	A AMMO PACK FOR MPSA28	2	2000	.52	2000	†
MPSA29	A SS DARLINGTON NPN TO92	1	5000	.48	5000	†
MPSA29RLRP	A AMMO PACK FOR MPSA29	2	2000	.48	2000	†
MPSA42	A SS HIGH VOLT NPN TO92	1	5000	.15	5000	†
MPSA42RLRA	A SS NPN TO92 TAPE/REEL2K	1	2000	.15	2000	†
MPSA42RLRE	A XSTR SIL T/R	2	2000	.15	2000	†
MPSA42RLRF	A REEL PACK FOR MPSA42	2	2000	.15	2000	†
MPSA42RLRM	A AMMO PACK FOR MPSA42	N	2000	.15	2000	†
MPSA42RL1	A XSTR SIL NPN	2	2000	.15	2000	†
MPSA43	A SS HIGH VOLT NPN TO92	2	5000	.24	5000	†
MPSA43RLRA	A XSTR SIL NPN	2	2000	.24	2000	†
MPSA44	A SS HIGH VOLT NPN TO92	1	5000	.34	5000	†
MPSA44RLRA	A REEL PACK FOR MPSA44	2	2000	.34	2000	†
MPSA44RL1	A REEL PACK FOR MPSA44	2	2000	.34	2000	†
MPSA55	A SS GEN PUR PNP TO92	1	5000	.12	5000	†
MPSA55RLRA	A SS PNP TP92 TAPE/REEL2K	2	2000	.12	2000	†
MPSA56	A SS GEN PUR PNP TO92	1	5000	.10	5000	†
MPSA56RLRA	A SS PNP TO92 TAPE/REEL2K	2	2000	.10	2000	†
MPSA56RLRM	A SS GP PNP TO92 AMMOPK	N	2000	.10	2000	†

Type No.	Grp/Description	Per Unit Sugg.		Factory Order	Incrmnt	
		Resale Price	Price			
MPSA56RLRP	A REEL PACK FOR MPSA56	N	2000	.10	2000	†
MPSA63	A SS DARLINGTON PNP TO92	1	5000	.12	5000	†
MPSA63RLRA	A SS PNP TP92 TAPE/REEL2K	3	2000	.77	2000	†
MPSA64	A SS DARLINGTON PNP TO92	1	5000	.14	5000	†
MPSA64RLRM	A SS DARLINGTON PNP TO92	2	2000	.14	2000	†
MPSA70	A LAST ORDER DATE:08/28/98	2	5000	.07	5000	†
MPSA70RLRM	A SS AMPL PNP TO92 T/R	N	2000	.07	2000	†
MPSA75	A SS DARLINGTON PNP TO92	2	5000	.50	5000	†
MPSA77	A SS DARLINGTON PNP TO92	2	5000	.50	5000	†
MPSA77RLRA	A REEL PACK FOR MPSA77	2	2000	.50	2000	†
MPSA92	A SS HIGH VOLT PNP TO92	1	5000	.16	5000	†
MPSA92RLRA	A SS PNP TP92 TAPE/REEL2K	2	2000	.16	2000	†
MPSA92RLRE	A XSTR SIL PNP	2	2000	.16	2000	†
MPSA92RL1	A XSTR SIL PNP	2	2000	.16	2000	†
MPSA93	A SS HIGH VOLT PNP TO92	2	5000	.30	5000	†
MPSA93RLRA	A XSTR SIL PNP	2	2000	.30	2000	†
MPSA93RLRM	A REEL PACK FOR MPSA93	2	2000	.30	2000	†
MPSH10	A SS AMPLIFIER NPN TO92	1	5000	.22	5000	†
MPSH10RLRA	A SS NPN TO92 TAPE/REEL2K	2	2000	.22	2000	†
MPSH10RLRP	A XSTR SM SIG PLAS/NPN-A/P	N	2000	.22	2000	†
MPSH11	A SS AMPLIFIER NPN TO92	2	5000	.36	5000	†
MPSH17	A SS AMPLIFIER NPN TO92	2	5000	.37	5000	†
MPSH17RLRA	A REEL PACK FOR MPSH17	2	2000	.37	2000	†
MPSH81	A LAST ORDER DATE:09/20/98	1	5000	.22	5000	†
MPSL01	A LAST ORDER DATE:08/28/98	2	5000	.20	5000	†
MPSW01	A SS HIGH CUR NPN TO92 A/P	2	5000	.30	5000	†
MPSW01A	A SS HIGH CUR NPN TO92	2	5000	.64	5000	†
MPSW01ARLRA	A REEL PACK FOR MPSW01A	2	2000	.64	2000	†
MPSW01ARLRP	A REEL PACK FOR MPS01A	2	2000	.64	2000	†
MPSW05	A SS GEN PUR NPN TO92	2	5000	.64	5000	†
MPSW06	A SS GEN PUR NPN TO92	2	5000	.68	5000	†
MPSW06RLRA	A REEL PACK FOR MPSW06	2	2000	.68	2000	†
MPSW10	A LAST ORDER DATE:08/28/98	3	5000	.91	5000	†
MPSW13	A SS DARLINGTON NPN TO92	2	5000	.72	5000	†
MPSW13RLRA	A REEL PACK FOR MPSW13	2	2000	.72	2000	†
MPSW14	A SS DARLINGTON NPN TO92	2	5000	1.52	5000	†
MPSW42	A SS HIGH VOLT NPN TO92	1	5000	.40	5000	†
MPSW42RLRA	A REEL PACK FOR MPSW42	2	2000	.40	2000	†
MPSW45	A SS DARLINGTON NPN TO92	2	5000	.30	5000	†
MPSW45A	A XSTR SM SIG PLAS1W NPN	2	5000	.36	5000	†
MPSW51	A SS HIGH CUR PNP TO92	2	5000	.36	5000	†
MPSW51A	A SS HIGH CUR PNP TO92	2	5000	.38	5000	†
MPSW51ARLRA	A XSTR SIL PLAS PNP	2	2000	.38	2000	†
MPSW55	A SS AMPLIFIER PNP TO92	3	5000	1.44	5000	†
MPSW56	A SS AMPLIFIER PNP TO92	3	5000	2.76	5000	†

A = OSPD/Power
 B = Analog/Logic
 J = Transportation
 L = Consumer
 N = Networking
 V = Wireless

S = Proprietary Device
 B = Motorola Blue Chip Program Device
 P = Phoenix Program
 * = First Time in Book
 † = \$200 Minimum Waived

N = Key New Motorola Device
 R = Key "Focus" Motorola Device

1 = Mature, Stable, High-Volume Device
 2 = Moderate-Volume Device
 3 = Low-Volume Device

COMMERCIAL COMPONENTS

Type No.	Grp/Description	Per Unit Sugg. Factory			†	Type No.	Grp/Description	Per Unit Sugg. Factory			†		
		PC	Qty	Price				Order	PC	Qty		Price	Order
MPSW56RLRA	A REEL PACK FORMPSW56	2	2000	1.60	2000	†	MPS651RLRB	A REEL PACK FORMPS651	2	2000	.60	2000	†
MPSW63	A SS DARLINGTON PNP TO92	2	5000	1.76	5000	†	MPS6521	A SS AMPLIFIER NPNT092	1	5000	.16	5000	†
MPSW63RLRA	A REEL PACK FORMPSW63	2	2000	1.76	2000	†	MPS6523	A SS AMPLIFIER NPNT092	2	5000	.18	5000	†
MPSW64	A SS DARLINGTON PNP TO92	3	5000	3.31	5000	†	MPS6601	A SS AMPLIFIER NPNT092	2	5000	.22	5000	†
MPSW92	A SS HIGH VOLTAGE PNP TO92	2	5000	.96	5000	†	MPS6602	A SS AMPLIFIER NPNT092	2	5000	1.28	5000	†
MPS2222	A SS GEN PUR NPNT092	2	5000	.084	5000	†	MPS6651	A SS AMPLIFIER PNP TO92	2	5000	.30	5000	†
MPS2222A	A SS GEN PUR NPNT092	1	5000	.084	5000	†	MPS6652	A SS AMPLIFIER NPNT092	2	5000	.29	5000	†
MPS2222ARLRA	A SS NPNT092 TAPE/REEL2K	1	2000	.084	2000	†	MPS6717	A SS AMPLIFIER NPNT092	2	5000	.36	5000	†
MPS2222ARLRM	A SS GP NPNT092 AMMO PK	N	2000	.084	2000	†	MPS6717RLRA	A SS AMPLIFIER NPNT092 T/R	2	2000	.36	2000	†
MPS2222RLRA	A SS NPNT092 TAPE/REEL2K	3	2000	.28	2000	†	MPS6724	A SS DARLINGTON NPNT092	2	5000	.36	5000	†
MPS2222RLRM	A SS GP NPNT092 AMMO PK	N	2000	.084	2000	†	MPS6725	A SS DARLINGTON NPNT092	2	5000	.38	5000	†
MPS2369	A SS SWITCHING NPNT092	1	5000	.19	5000	†	MPS6725RLRP	A AMMO PACK FORMPS6725	2	2000	.38	2000	†
MPS2369A	A XSTR SM SIG PLAS NPN	2	5000	.20	5000	†	MPS6726	A SS AMPLIFIER PNP TO92	2	5000	.30	5000	†
MPS2907	A SS GEN PUR PNP TO92	2	5000	.082	5000	†	MPS6727	A SS AMPLIFIER PNP TO92	2	5000	.60	5000	†
MPS2907A	A SS GEN PUR PNP TO92	1	5000	.082	5000	†	MPS6729	A SS AMPLIFIER PNP TO92	2	5000	.36	5000	†
MPS2907ARLRA	A SSPNP TP92 TAPE/REEL2K	1	2000	.082	2000	†	MPS750	A SS HIGH CUR PNP TO92	1	5000	.66	5000	†
MPS2907ARLRM	A REEL PACK FORMPS2907	N	2000	.082	2000	†	MPS750RLRA	A SS HIGH CUR PNP TO92 T/R	2	2000	.66	2000	†
MPS2907RLRP	A AMMO PACK FORMPS2907	2	2000	.068	2000	†	MPS750RLRP	A SS HIGH CUR PNP TO92 T/A	2	2000	.66	2000	†
MPS3563	A SS AMPLIFIER NPNT092	2	5000	.18	5000	†	MPS751	A SS GEN PUR NPNT092	2	5000	.54	5000	†
MPS3638A	A SS SWITCHING PNP TO92	2	5000	.17	5000	†	MPS751RLRA	A REEL PACK FORMPS751	2	2000	.54	2000	†
MPS3640	A SS SWITCHING PNP TO92	2	5000	.22	5000	†	MPS8098	A SS AMPLIFIER NPNT092	2	5000	.22	5000	†
MPS3646	A SS SWITCHING NPNT092	2	5000	.20	5000	†	MPS8098RLRA	A REEL PACK FORMPS8098	N	2000	.22	2000	†
MPS3646RLRA	A REEL PACK FORMPS3646	2	2000	.20	2000	†	MPS8099	A SS AMPLIFIER NPNT092	1	5000	.22	5000	†
MPS3702	A SS AMPLIFIER PNP TO92	2	5000	.56	5000	†	MPS8099RLRA	A REEL PACK/MPS8099	N	2000	.22	2000	†
MPS404A	A SS CHOPPER PNP TO92	2	5000	.36	5000	†	MPS8598	A SS AMPLIFIER NPNT092	2	5000	.21	5000	†
MPS404ARLRA	A REEL PACK FORMPS404ARLRA	2	2000	.36	2000	†	MPS8598RLRA	A REEL PACK FORMPS8598	2	2000	.21	2000	†
MPS4123	A SS GEN PUR NPNT092	2	5000	.07	5000	†	MPS8599	A SS AMPLIFIER PNP TO92	1	5000	.21	5000	†
MPS4124	A SS GEN PUR NPNT092	2	5000	.07	5000	†	MPS8599RLRA	A REEL PACK FORMPS8599	N	2000	.21	2000	†
MPS4124RLRA	A SS NPNT092 TAPE/REEL2K	2	2000	.07	2000	†	MPS901	V LAST ORDER DATE:12/01/98	2	5000	.39	5000	
MPS4124RLRE	A LAST ORDER DATE:08/28/98	2	2000	.07	2000	†	MPS901RLRP	V LAST ORDER DATE:12/01/98	2	2000	.39	2000	
MPS4125RLRA	A SSPNP TP92 TAPE/REEL2K	3	2000	.35	2000	†	MPS918	A SS OSC/MIXER NPNT092	2	5000	.18	5000	†
MPS4126	A SS GEN PUR PNP TO92	2	5000	.07	5000	†	MPTE-005	A ZEN5V1500WC41-11	2	500	.69	500	†
MPS4126RLRA	A SSPNP TP92 TAPE/REEL2K	2	2000	.07	2000	†	MPTE-008	A ZEN9.4V1500WC41-11	3	500	1.36	500	†
MPS4250	A SS AMPLIFIER PNP TO92	2	5000	.12	5000	†	MPTE-010	A ZEN10V1500WC41-11	2	500	.68	500	†
MPS4250ARLRM	A XSTR SIL PLAS PNP	2	2000	.12	2000	†	MPTE-015	A ZEN15V1500WC41-11	2	500	.68	500	†
MPS5172	A SS AMPLIFIER NPNT092	2	5000	.072	5000	†	MPTE-018	A ZEN18V1500WC41-11	3	500	1.36	500	†
MPS5179	A SS HIGH FREQ NPNT092	1	5000	.34	5000	†	MPTE-022	A ZEN22V1500WC41-11	3	500	1.36	500	†
MPS5179RLRA	A REEL PACK FORMPS5179	2	2000	.34	2000	†	MPXL10GC7U	J PRESSEN UNCOMP	N	1	6.53	1 *	
MPS5179RLRP	A SS HIGH FREQ NPN AMMOPAK	2	2000	.34	2000	†	MPXL5010GC7U	J INTEGRATED PRESSEN	N	25	13.16	25	B
MPS571	V LAST ORDER DATE:12/01/98	2	5000	.65	5000		MPXL5010G7U	J INTEGRATED PRESSEN	N	25	12.63	25	B
MPS6428RLRA	A SIL PLAS SMSIG	2	2000	.16	2000	†	MPXS4100AC6U	J PRESSEN INTEG100KPA	N	1	15.95	1 *	
MPS650	A SS HIGH CUR NPNT092	2	5000	.52	5000	†	MPXS4100A6U	J PRESSEN INTEG100KPA	N	25	15.23	25	
MPS6507	A SS AMPLIFIER NPNT092	2	5000	.30	5000	†	MPXS4115AC6U	J PRESSEN BAP AXL PORT	N	25	15.95	25	
MPS651	A SS HIGH CUR NPNT092	1	5000	.60	5000	†	MPXS4115A6U	J PRESSEN BAP AXL PORT	N	1	15.23	1 *	
MPS651RLRA	A REEL PACK FORMPS651	2	2000	.60	2000	†	MPXT2010G7U	J PRESSEN COMP10KPA	N	25	13.78	25	

A = OSPD/Power
B = Analog/Logic
J = Transportation
L = Consumer
N = Networking
V = Wireless

S = Proprietary Device
B = Motorola Blue Chip Program Device
P = Phoenix Program
* = First Time in Book
† = \$200 Minimum Waived

N = Key New Motorola Device
R = Key "Focus" Motorola Device

1 = Mature, Stable, High-Volume Device
2 = Moderate-Volume Device
3 = Low-Volume Device

EFFECTIVE DATE: JANUARY 10, 1998

COMMERCIAL COMPONENTS

Type No.	Grp/Description	Per Unit Sugg. Factory			
		Resale Price	Price	Order	
PC	Qty	Price	Incrmnt		
MPXT4100A7U	J PRESSENINTEG15PSI4V	N	1	15.23	1
MPXT4101A7U	J PRESSENINTEG102KPA	N	25	15.23	25
MPXT4105A7U	J PRESSENINTEG105KPA	N	25	15.23	25
MPXT4205A7U	J PRESXSTR,MAP	N	1	15.23	1★
MPXT5006D	J INTEGRPRES TRANSDUCER	N	20	16.16	20★ B
MPXT5006DF	J INTEGRPRES TRANSDUCER	N	20	16.69	20★ B
MPX10D	J PRESSENUNCOMP10KPA	N	25	5.80	25
MPX10DP	J PRESSENUNCOMP10KPA	2	20	7.25	20
MPX10GP	J PRESSENUNCOMP10KPA	2	20	6.53	20
MPX10GS	J PRESSENUNCOMP10KPA	N	20	6.53	20
MPX100A	J PRESSENUNCOMP100KPA	2	25	5.80	25
MPX100AP	J PRESSENABS PORT	2	20	6.53	20
MPX100AS	J PRESSENUNCOMP100KPA	2	20	6.53	20
MPX100D	J PRESSENUNCOMP100KPA	N	25	5.80	25
MPX100DP	J PRESSENUNCOMP100KPA	N	20	7.25	20
MPX100GP	J PRESSENUNCOMP100KPA	2	20	6.53	20
MPX12D	J PRESSENUNCOMP12KPA	N	25	5.80	25
MPX12DP	J PRESSENUNCOMP12KPA	N	20	7.25	20
MPX12GP	J PRESSENUNCOMP12KPA	N	20	6.53	20
MPX200D	J PRESSENUNCOMP200KPA	2	25	5.80	25
MPX200DP	J PRESSENUNCOMP200KPA	N	20	7.25	20
MPX200GP	J PRESSENUNCOMP200KPA	2	20	6.53	20
MPX2010D	J PRESSENCOMP10KPA	2	25	13.78	25
MPX2010DP	J PRESSENCOMP10KPA	1	20	15.23	20 S
MPX2010GP	J PRESSENCOMP10KPA	2	20	14.50	20 S
MPX2010GS	J PRESSENCOMP10KPA	2	20	14.50	20 S
MPX2050D	J PRESSENCOMP50KPA	2	25	13.78	25
MPX2050DP	J PRESSENCOMP50KPA	2	20	15.23	20
MPX2050GP	J PRESSENCOMP50KPA	2	20	14.50	20
MPX2100A	J PRESSENCOMP100KPA	2	25	13.78	25
MPX2100AP	J PRESSENCOMP100KPA	2	20	14.50	20
MPX2100D	J PRESSENCOMP100KPA	2	25	13.78	25
MPX2100DP	J PRESSENCOMP100KPA	2	20	15.23	20
MPX2100GP	J PRESSENCOMP100KPA	2	20	14.50	20
MPX2200A	J PRESSENCOMP200KPA	N	25	13.78	25★
MPX2200AP	J PRESSENCOMP200KPA	2	20	14.50	20
MPX2200D	J PRESSENCOMP200KPA	N	25	13.78	25★
MPX2200DP	J PRESSENCOMP200KPA	2	20	15.23	20
MPX2200GP	J PRESSENCOMP200KPA	2	20	14.50	20
MPX2300DT1	J PRESSENCOMP300MMHG	2	1000	4.35	1000
MPX2700A	J PRESSENCOMP700KPA	N	25	13.78	25★
MPX2700AS	J PRESSENCOMP700KPA	N	20	14.50	20
MPX2700D	J PRESSENCOMP700KPA	N	25	13.78	25
MPX2700DP	J PRESSENCOMP700KPA	N	20	15.23	20
MPX4100A	J PRESSENINTEG100KPA	N	25	15.23	25

Type No.	Grp/Description	Per Unit Sugg. Factory			
		Resale Price	Price	Order	
PC	Qty	Price	Incrmnt		
MPX4100AP	J PRESSENINTEG100KPA	N	20	15.95	20
MPX4100AS	J PRESSENINTEG100KPA	N	20	15.95	20★
MPX4101A	J PRESSENINTEG100KPA	N	25	15.23	25
MPX4105A	J PRESSENINTEG100KPA	N	25	15.23	25
MPX4115A	J PRESSENINTEG115KPA	N	25	15.23	25
MPX4115AP	J PRESSENINTEG115KPA	N	20	15.95	20
MPX4200A	J PRESSENINTEG200KPA	N	25	15.23	25
MPX4250A	J PRESSENINTEG250KPA	N	25	15.23	25
MPX4250AP	J PRESSENINTEG250KPA	N	20	15.95	20
MPX50DP	J PRESSENUNCOMP50KPA	N	20	7.25	20
MPX50GP	J PRESSENUNCOMP50KPA	2	20	6.53	20
MPX5010D	J PRESSENINTEG10KPA	N	25	12.63	25 B
MPX5010DP	J PRESSENINTEG10KPA	N	20	13.69	20 B
MPX5010DP1	J PRESSENINTEG10KPA	N	20	14.21	20 B
MPX5010GP	J PRESSENINTEG10KPA	N	20	13.16	20 B
MPX5010GS	J PRESSENINTEG10KPA	N	20	13.16	20
MPX5050D	J PRESSENINTEG50KPA	2	25	12.63	25 B
MPX5050DP	J PRESSENINTEG50KPA	2	20	13.69	20 B
MPX5050GP	J PRESSENINTEG50KPA	2	20	13.16	20 B
MPX5100A	J PRESSENINTEG100KPA	2	25	12.63	25 B
MPX5100AP	J PRESSENINTEG100KPA	2	20	13.16	20 B
MPX5100D	J PRESSENINTEG100KPA	2	25	12.63	25 B
MPX5100DP	J PRESSENINTEG100KPA	2	20	13.69	20 B
MPX5100GP	J PRESSENINTEG100KPA	2	20	13.16	20 B
MPX5700D	J PRESSENINTEG700KPA	N	25	12.63	25 B
MPX5700DP	J PRESSENINTEG700KPA	N	20	13.69	20 B
MPX5700GP	J PRESSENINTEG700KPA	N	20	13.16	20 B
MPX5999D	J PRESSENINTEG1000KPA	N	25	12.63	25 B
MPX7050D	J PRESSENCOMP50KPA	N	25	13.78	25
MPX7050DP	J PRESSENCOMP50KPA	N	20	15.23	20
MPX7050GP	J PRESSENCOMP50KPA	N	20	14.50	20
MPX7100A	J PRESSENCOMP100KPA	N	25	13.78	25
MPX7100D	J PRESSENCOMP100KPA	N	25	13.78	25
MPX7100DP	J PRESSENCOMP100KPA	N	20	15.23	20
MPX7100GP	J PRESSENCOMP100KPA	N	20	14.50	20
MPX7200A	J PRESSENCOMP200KPA	N	25	13.78	25
MPX7200D	J PRESSENCOMP200KPA	N	25	13.78	25
MPX7200GP	J PRESSENCOMP200KPA	N	20	14.50	20
MRA0510-50H	N RF NPN HIPWR HERMETIC FLG	1	13	174.40	13
MRA1000-14L	N RF NPN HIPWR SOE STUD	2	20	78.65	20
MRA1000-7L	N RF NPN HIPWR SOE STUD	2	20	60.06	20
MRA1720-020	N RF NPN HIPWR SOE FLANGE	2	20	220.00	20
MRA4003T3	A IR200V <10 MICRO AMP25C	R	5000	.10	5000 †
MRA4004T3	A IR400V <10 MICRO AMP25C	R	5000	.10	5000 †
MRA4005T3	A IR600V <10 MICRO AMP25C	R	5000	.10	5000 †

A = OSPD/Power
 B = Analog/Logic
 J = Transportation
 L = Consumer
 N = Networking
 V = Wireless

S = Proprietary Device
 B = Motorola Blue Chip Program Device
 P = Phoenix Program
 ★ = First Time in Book
 † \$200 Minimum Waived

N = Key New Motorola Device
 R = Key "Focus" Motorola Device

1 = Mature, Stable, High-Volume Device
 2 = Moderate-Volume Device
 3 = Low-Volume Device

COMMERCIAL COMPONENTS

Type No.	Grp/Description	Per PC	Unit Qty	Sugg. Resale Price	Factory Order Price	Order Incrmnt	Type No.	Grp/Description	Per PC	Unit Qty	Sugg. Resale Price	Factory Order Price	Order Incrmnt
MRA4006T3	A IR800V<10MICROAMP25C	R	5000	.11	5000	†	MRF151G	N RF FETHIPWR SOE FLANGE	1	10	161.00	10	
MRA4007T3	A IR1000V<10MICRAMP25C	R	5000	.11	5000	†	MRF154	N RF FETHIPWR SOE FLANGE	2	6	539.11	6	S
MRFA2604	N LAST ORDERDATE:11/28/98	N	1	1215.50	1		MRF157	N RF TMOSFET	2	6	564.85	6	S
MRFC0001R2	V RF SILBIPLR MIC TSSOP-20	2	2500	4.52	2500	S	MRF158	N RF APNCHAN	2	20	21.19	20	
MRFC0903R2	V RF GAAS MIC SO-8	2	2500	4.52	2500	S	MRF160	N RF MOSFET BROADBAND PRFET	N	20	20.93	20	
MRFC0904R2	V RF GAAS MIC SO-16	2	2500	4.39	2500	S	MRF16006	N RF NPN HIPWR SOE FLANGE	N	20	99.00	20	
MRFC0912R2	V RF IC POWERLINE	N	1500	7.32	1500		MRF16030	N RF NPN HIPWR SOE FLANGE	N	20	123.75	20	
MRFC0913R2	V RF MMIC GAAS 4.8V IPA	N	1500	8.65	1500		MRF163	N RF FETHIPWR SOE STUD	2	20	28.88	20	
MRFC0916T1	V MMIC, RF CASCODE AMP T/R	2	3000	.98	3000	S	MRF166C	N RF N-CHPWR FET FLG PKG	2	20	31.45	20	
MRFC0931R2	V BALANCED TX MXR.	N	2500	3.79	2500		MRF166W	N RF TMOS BROADBAND PWR FET	2	15	77.38	15	
MRFC1501R2	V RF IC GPS LNA	N	2500	3.33	2500		MRF173	N RF FETHIPWR SOE FLG	2	20	38.65	20	
MRFC1502R2	V RF IC LN	N	3000	7.32	3000		MRF173CQ	N RF FETHIPWR SOE FLG	2	20	36.10	20	
MRFC1801R2	V RF GAAS MIC SO-8	N	2500	2.23	2500	S	MRF174	N RF FETHIPWR SOE FLANGE	2	20	72.38	20	
MRFC1803R2	V RF GAAS MIC SO-16	N	2500	4.85	2500	S	MRF175GU	N RF FETHIPWR SOE FLANGE	2	10	152.46	10	
MRFC1804R2	V RF GAAS MIC SO-16	N	2500	4.92	2500	S	MRF175GV	N RF FETHIPWR SOE FLANGE	2	10	146.30	10	
MRFC1805R2	V GAS PWR AMP TSSOP PKG T/R	N	2500	4.23	2500		MRF177	N RF FETHIPWR P-PKG	2	20	68.53	20	
MRFC1806R2	V RF GAAS MIC SO-16	2	2500	3.22	2500	S	MRF182	N RF PWR FET SOE FLANGE	1	20	68.64	20	
MRFC1807R2	V RF GAAS MIC SO-16	2	2500	3.52	2500	S	MRF183	N RF PWR FET SOE FLANGE	N	20	75.79	20	
MRFC1808R2	V RF IC POWERLINE	2	2500	1.93	2500	S	MRF184	N RF PWR FET SOE FLANGE	N	20	97.24	20	
MRFC2001R2	V RF SILICON MIC SO-8 T/R	N	2500	2.79	2500	S	MRF185	N GEMINI PUSH PULL 80 WATTS	N	10	228.80	10	
MRFC2002R2	V RF SILICON MIC SO-8 T/R	N	2500	2.79	2500	S	MRF1946	N RF NPN HIPWR SOE FLANGE	2	20	15.05	20	
MRFC2004R2	V RF SIL MIC SO-16 T/R	N	2500	3.46	2500	S	MRF20030	N RF PWR XSTR	N	20	115.71	20	
MRFC2006R2	V RF SIL MIC SO-8 T/R	N	2500	2.79	2500	S	MRF20060	N PWR XSTR, 2GHZ, 60W	N	20	226.10	20	
MRFC2101R2	V 900MHZ TRANS MIXER/EXCITR	N	2500	4.59	2500	S	MRF224	N RF NPN HIPWR SOE FLANGE	2	20	15.60	20	
MRFC2401R2	V RF GAAS MIC SOIC16	N	2500	5.52	2500	S	MRF227	N RF NPN HIPWR TO-39CE	2	200	7.65	200	
MRFC2403R2	V RF GAAS MIC SO-16 T/R	N	2500	5.45	2500	S	MRF237	N RF NPN HIPWR TO-39CE	1	200	7.06	200	
MRFC2404R2	V RF GAAS MIC SO-8	N	2500	3.72	2500	S	MRF240	N RF NPN HIPWR SOE STUD	2	20	18.50	20	
MRF1000MA	N LAST ORDERDATE:07/21/98	2	20	49.90	20		MRF247	N RF NPN HIPWR SOE FLANGE	1	20	31.19	20	
MRF1001A	V RF NPN LO PWR TO-39	2	500	4.08	500		MRF255	N RF PWR XSTR	N	20	47.19	20	
MRF10031	N RF NPN HIPWR SOE FLANGE	2	99	130.13	99		MRF2628	N RF NPN HIPWR SOE STUD	2	20	10.40	20	
MRF10120	N RF NPN PULSE PWR HERM FLG	2	3	234.08	3		MRF275G	N RF PWR TMOS FET	N	10	162.31	10	*
MRF10150	N RF NPN HIPWR SOE FLG	2	3	305.90	3		MRF275L	N TMOS FET 100W 28V	N	20	85.80	20	*
MRF10350	N RF NPN HIPWR SOE FLG	2	3	393.68	3		MRF282SC	N RF PWR FET SOE PKG	N	20	66.50	20	
MRF10500	N RF NPN HIPWR SOE FLG	2	3	466.00	3		MRF284C	N RF PWR FET	N	20	99.75	20	
MRF10501	N RF NPN HIPWR SOE FLG	N	3	465.50	3		MRF284SC	N RF PWR FET	N	20	99.75	20	
MRF134	N RF FETHIPWR SOE FLANGE	1	20	18.71	20		MRF2947AT1	V RF LOW PWR SC-70	N	3000	.72	3000	*
MRF136	N RF FETHIPWR SOE FLANGE	1	20	22.30	20		MRF3094	N L-BAND BIPLR PWR TRNSISTR	N	20	64.35	20	
MRF136Y	N RF FETHIPWR SOE FLANGE	2	20	61.30	20		MRF3096	N L-BAND BIPLR PWR TRNSISTR	N	20	83.16	20	
MRF137	N RF FETHIPWR SOE FLANGE	2	20	26.55	20		MRF314	N RF NPN HIPWR SOE FLANGE	2	20	29.35	20	
MRF141G	N RF FETHIPWR SOE FLANGE	1	10	152.95	10		MRF317	N RF NPN HIPWR SOE FLANGE	2	20	70.05	20	
MRF148	N RF FETHIPWR SOE FLANGE	1	20	41.40	20		MRF321	N RF NPN HIPWR SOE STUD	2	20	22.95	20	
MRF150	N RF FETHIPWR SOE FLANGE	1	20	60.06	20		MRF323	N RF NPN HIPWR SOE STUD	2	20	31.46	20	
MRF15030	N RF NPN HI-POWER	N	20	171.60	20		MRF327	N RF NPN HIPWR SOE FLANGE	2	20	61.30	20	
MRF15060	N RF L/MMOBILE NPN	N	20	207.35	20		MRF329	N RF NPN HIPWR SOE FLANGE	2	20	79.15	20	
MRF151	N RF FETHIPWR SOE	N	20	67.21	20		MRF392	N RF NPN HIPWR P-P FLANGE	2	20	114.00	20	

A = OSPD/Power
 B = Analog/Logic
 J = Transportation
 L = Consumer
 N = Networking
 V = Wireless

S = Proprietary Device
 B = Motorola Blue Chip Program Device
 P = Phoenix Program
 * = First Time in Book
 † \$200 Minimum Waived

N = Key New Motorola Device
 R = Key "Focus" Motorola Device

1 = Mature, Stable, High-Volume Device
 2 = Moderate-Volume Device
 3 = Low-Volume Device

EFFECTIVE DATE: JANUARY 10, 1998

COMMERCIAL COMPONENTS

Type No.	Grp/Description	Per Unit Sugg.		Factory Order	
		Resale Price	Price		
PC	Qty	Price	Incrmnt		
MRF393	N RF NPN HIPWR-P FLANGE	2	20	119.00	20
MRF421	N RF NPN HIPWR SOE FLANGE	2	20	36.95	20
MRF422	N RF NPN HIPWR SOE FLANGE	2	20	41.60	20
MRF426	N RF NPN HIPWR SOE FLANGE	2	20	18.50	20
MRF429	N RF NPN HIPWR SOE FLANGE	2	20	46.20	20
MRF4427R2	V RF NPN LO PWR T/R	N	2500	.86	2500
MRF448	N RF NPN HIPWR SOE FLANGE	2	20	80.85	20
MRF454	N RF NPN HIPWR SOE FLANGE	1	20	14.17	20
MRF455	N RF NPN HIPWR SOE FLANGE	1	20	11.63	20
MRF492	N RF NPN HIPWR SOE FLANGE	2	20	23.10	20
MRF5003	N RF FET HI PWR SURFACE MT	N	100	9.16	100
MRF5007	N RF FET HI PWR SURFACE MT	N	100	23.17	100
MRF5015	N RF NCHAN FET6LDFLG	N	20	27.46	20
MRF5035	N RF NCHAN FET6LDFLG	N	20	35.58	20
MRF517	V RF NPN LO PWR TO-39	2	500	5.36	500
MRF5211LT1	V REEL PACK FOR MRF5211LT1	2	3000	1.23	3000
MRF531	V RF NPN LO PWR TO-39	2	500	3.70	500
MRF544	V RF NPN LO PWR TO-39	1	500	4.44	500
MRF545	V RF PNP LO PWR TO-39	1	500	5.08	500
MRF548	V RF LOW PWR NPN	2	20	9.16	20
MRF549	V RF PNP LO PWR SOE STUD	2	20	10.47	20
MRF555	V RF NPN LO PWR POWER MACRO	2	1000	2.90	1000
MRF557	V RF NPN LO PWR POWER MACRO	2	1000	3.47	1000
MRF559	V RF NPN LO PWR MACRO-X	2	1000	1.08	1000
MRF571	V RF NPN LO PWR MACRO-X	1	1000	1.05	1000
MRF5711LT1	V REEL PACK FOR MRF5711LT1	2	3000	1.00	3000
MRF577T1	V TRANSISTOR RF	N	3000	.43	3000
MRF581	V RF NPN LO PWR MACRO-X	1	1000	1.46	1000
MRF581A	V RF NPN LO PWR MACRO-X	2	1000	1.69	1000
MRF5811LT1	V RF NPN LOW PWR SOT-143	N	3000	1.29	3000
MRF5812	V RF NPN LO PWR SO-8	2	98	1.85	98
MRF5812R1	V RF NPN LO PWR SO-8	2	500	1.85	500
MRF586	V RF NPN LO PWR TO-39	1	500	2.88	500
MRF587	N RF NPN LO PWR SOE STUD	2	20	14.01	20
MRF5943R2	V REEL PACK FOR MRF5943	N	2500	.92	2500 *
MRF630	N RF NPN HIPWR TO-39CE	1	200	8.24	200
MRF6401	N 0.5W1.86GHZ POWER TRANS	N	20	51.48	20
MRF6402	N MICROWAVE LINEAR TRANS	N	20	60.06	20
MRF6404K	N RFL/MOBILE	N	20	99.75	20
MRF6408	N 12W/1.8GHZ PCN BASE START	N	20	93.10	20
MRF6409	N NPN RF TRANSISTOR	N	20	99.75	20
MRF641	N RF NPN HIPWR SOE FLANGE	2	20	20.55	20
MRF6414	N SILICON RF TRANS	N	20	143.00	20
MRF644	N RF NPN HIPWR SOE FLANGE	2	20	25.74	20
MRF646	N RF NPN HIPWR SOE FLANGE	2	20	29.65	20

Type No.	Grp/Description	Per Unit Sugg.		Factory Order	
		Resale Price	Price		
PC	Qty	Price	Incrmnt		
MRF652	N RF NPN HIPWR SOE STUD	2	20	12.40	20
MRF652S	N RF NPN HIPWR SOE STUD	2	20	12.40	20
MRF654	N RF NPN HIPWR SOE STUD	2	20	20.85	20
MRF658	N RF NPN HIPWR SOE FLANGE	2	20	35.25	20
MRF752	N RF NPN HIPWR CER PILL	2	20	20.17	20
MRF837	V RF NPN LO PWR MACRO-X	2	1000	1.93	1000
MRF8372R2	V 900NPN0.75W12V SO-8	N	2500	1.57	2500 *
MRF839	N LAST ORDER DATE:11/05/98	2	20	18.79	20
MRF841F	N LAST ORDER DATE:11/05/98	N	20	36.75	20
MRF846	N LAST ORDER DATE:11/05/98	2	20	45.05	20
MRF847	N RF NPN HIPWR SOE FLANGE	2	20	40.36	20
MRF857S	N RF HIPWR SOE PILL	N	20	21.55	20
MRF858	N RF NPN HIPWR SOE FLANGE	N	20	28.18	20
MRF859	N SILICON RF PWR XSTR	N	20	48.62	20
MRF859S	N SILICON RF PWR XSTR	N	50	48.62	50
MRF892	N LAST ORDER DATE:05/10/98	2	20	32.34	20
MRF894	N RF NPN HIPWR SOE FLANGE	2	20	46.20	20
MRF896	N LAST ORDER DATE:11/05/98	2	20	20.79	20
MRF897	N RF HIPWR-P FLANGE	2	20	127.82	20
MRF897R	N RF HIPWR-P FLANGE	N	20	127.82	20
MRF898	N RF NPN HIPWR SOE FLANGE	2	20	93.94	20
MRF899	N RF NPN HIPWR-P FLANGE	1	10	214.50	10
MRF901	V RF NPN LO PWR MACRO-X	2	1000	.85	1000
MRF9011LT1	V LAST ORDER DATE:12/01/98	2	3000	.83	3000
MRF904	V RF NPN LO PWR TO-72	1	1000	2.31	1000
MRF917T1	V RF LO-PWR SC-70	N	3000	.30	3000
MRF927T1	V RF LO PWR SC-70	N	3000	.69	3000
MRF9331LT1	V LAST ORDER DATE:12/01/98	2	3000	.95	3000
MRF9411LT1	V RF NPN LO PWR SOT-143 T/R	2	3000	.65	3000
MRF947T1	V RF LO PWR SC-70	2	3000	.31	3000
MRF951	V RF NPN LO PWR MACRO-X	2	1000	1.62	1000
MRF9511LT1	V REEL PACK FOR MRF9511L	2	3000	1.57	3000
MRF9745T1	V PLD1-LV,1.54-CELL LDMOS	N	1000	3.00	1000
MRF9811T1	V RF LOW POWER	N	3000	1.10	3000 *
MRF9820T1	V RF LOW PWR	N	3000	1.10	3000
MRF9822T1	V RF HIFREQ XSTR	N	1000	5.65	1000
MRW2001	N RF NPN HIPWR SOE FLANGE	2	20	56.98	20
MRW2003	N RF NPN HIPWR SOE FLANGE	2	20	73.15	20
MRW2005	N LAST ORDER DATE:11/14/98	2	20	61.60	20
MRW3001	N RF NPN HIPWR SOE FLANGE	2	20	58.52	20
MRW3003	N RF NPN HIPWR SOE FLANGE	2	20	76.05	20
MRW52604	N LAST ORDER DATE:07/21/98	2	20	97.75	20
MRW54001	N RF NPN HIPWR CERAMIC SOE	2	20	61.79	20
MR10120E	A REC10A1200V STD220	3	50	7.12	50 †
MR2502	A REC25A200V STD REC BUTTON	2	5000	.47	5000 †

A = OSPD/Power
 B = Analog/Logic
 J = Transportation
 L = Consumer
 N = Networking
 V = Wireless

S = Proprietary Device
 B = Motorola Blue Chip Program Device
 P = Phoenix Program
 * = First Time in Book
 † \$200 Minimum Waived

N = Key New Motorola Device
 R = Key "Focus" Motorola Device

1 = Mature, Stable, High-Volume Device
 2 = Moderate-Volume Device
 3 = Low-Volume Device

COMMERCIAL COMPONENTS

Type No.	Grp/Description	Per Unit Sugg. Factory		Order	†	Type No.	Grp/Description	Per Unit Sugg. Factory		Order	†		
		PC	Qty					Price	Incrrmnt			PC	Qty
MR2504	A REC25A400VSTDRECBUTTON	2	5000	.47	5000	†	MTB23P06VT4	A TMOSPWRFETXSTR T/R	2	800	2.96	800	†
MR2510	A REC25A1KVSTDRECBOTTON	N	5000	1.60	5000	†	MTB3N100E	A TMOSPWRFET1000V4.00OH	N	50	3.50	50	†
MR2535L	A REC35A24-32VAVALAXIAL	1	1000	1.77	1000	†	MTB3N100ET4	A TMOSPWRFET1000V4.00OH	N	800	2.08	800	†
MR2535LRL	A REELPACKFORMR2535L	2	800	2.62	800	†	MTB3N120E	A PWR,FETXSTR,1200V,5OHMS	N	50	4.20	50	†
MR750	A REC6A50VSTDRECAAXIAL	1	1000	.46	1000	†	MTB3N120ET4	A PWR,FETXSTR,1200V,5OHMS	2	800	2.31	800	†
MR750RL	A REC6A50VSTDAXIAL	2	800	.52	800	†	MTB30N06EL	A FET TMOSPWR	2	50	3.32	50	†
MR751	A REC6A100VSTDRECAAXIAL	1	1000	.48	1000	†	MTB30N06VL	A TMOSV PWR FET60V0.05 OH	N	50	1.90	50	†
MR751RL	A REC6A100VSTDAXIAL	2	800	.57	800	†	MTB30N06VLT4	A TMOSV PWR FET60V0.05 OH	2	800	1.94	800	†
MR752	A REC6A200VSTDRECAAXIAL	1	1000	.48	1000	†	MTB30P06V	A XSTR, PWR FET,60V,.08 OHM	N	50	1.83	50	†
MR752RL	A REC6A200VSTDAXIAL	2	800	.56	800	†	MTB30P06VT4	A XSTR, PWR FET,60V,.08 OHM	N	800	1.32	800	†
MR754	A REC6A400VSTDRECAAXIAL	1	1000	.48	1000	†	MTB33N10E	A TMOSPWRFET100V	R	50	6.62	50	†
MR754RL	A REC6A400VSTDAXIAL	2	800	.56	800	†	MTB33N10ET4	A TMOSPWRFET100V	N	800	6.66	800	†
MR756	A REC6A600VSTDRECAAXIAL	1	1000	.53	1000	†	MTB36N06V	A TMOSPWRFET	N	50	1.53	50	†
MR756RL	A REC6A600VSTDAXIAL	2	800	.65	800	†	MTB36N06VT4	A TMOSPWRFET	N	800	1.09	800	†
MR760	A REC6A1KVSTDRECAAXIAL	1	1000	.60	1000	†	MTB4N80E	A TMOSPWRFET,800V,3.0 OHM	N	50	4.42	50	†
MR850	A REC3A50VFASTRCAAXIAL	2	500	.23	500	†	MTB4N80ET4	A TMOSPWRFET,800V,3.0 OHM	N	800	4.46	800	†
MR851	A REC3A100VFASTRCAAXIAL	1	500	.23	500	†	MTB50N06E	A SURFACE MOUNT D SQUARE PK	2	50	3.86	50	†
MR852	A REC3A200VFASTRCAAXIAL	2	500	.31	500	†	MTB50N06EL	A FET TMOSPWR	2	50	4.00	50	†
MR852RL	A REC3A200VFASTRCAAXIAL	2	1200	.29	1200	†	MTB50N06ET4	A TAPE AND REEL D SQUARE PK	2	800	3.90	800	†
MR854	A REC3A400VFASTRCAAXIAL	2	500	.31	500	†	MTB50N06V	A TMOSV FET,60V,.028 OHM	N	50	1.83	50	†
MR854RL	A REC3A400VFASTRCAAXIAL	2	1200	.29	1200	†	MTB50N06VL	A TMOSV FET,60V,.032 OHM	N	50	2.90	50	†
MR856	A REC3A600VFASTRCAAXIAL	1	500	.31	500	†	MTB50N06VLT4	A TMOSV FET,60V,.032 OHM	N	800	2.96	800	†
MR856RL	A REC3A600VFASTRCAAXIAL	2	1200	.29	1200	†	MTB50N06VT4	A TMOSV FET,60V,.028 OHM	N	800	1.29	800	†
MSD1010T1	A LOWPWR XSTR	2	3000	.17	3000	†	MTB50P03HDL	A TMOSPWRFET30V,0.025OHM	N	50	5.94	50	†
MSD6100	A SS DUAL SWITCH DIODE TO92	2	5000	.30	5000	†	MTB50P03HDLT4	A TMOSPWRFET30V,0.025OHM	N	800	4.00	800	†
MSD6150	A SS DUAL SWITCH DIODE TO92	2	5000	.32	5000	†	MTB52N06V	A TMOSV FET,60V,0.022OHM	N	50	2.00	50	†
MSRP10040	A PWR TAP,RECT,100A,400V	N	50	17.00	50	†	MTB52N06VL	A TMOSV FET,60V,0.025OHM	N	50	3.25	50	†
MTA1N60E	A POWER TMOS NCHAN	2	50	2.34	50	†	MTB52N06VT4	A TMOSV FET,60V,0.022OHM	N	800	1.43	800	†
MTA2N60E	A TMOSPWR2.2R600V FL PAK	2	50	2.94	50	†	MTB6N60E	A TMOSPWRFET600V1.20OH	N	50	4.34	50	†
MTA2955E	A TMOSPWR60V8A	N	50	2.04	50	†	MTB6N60ET4	A TMOSPWRFET600V1.20OH	N	800	4.38	800	†
MTA30N06E	A TMOSPWR60V.028R TO220	1	50	4.06	50	†	MTB60N06HD	A TMOSPWRFET60V,0.014OHM	N	50	4.50	50	†
MTA3055E	A TMOSPWR60V.15R TO220FP	N	50	1.06	50	†	MTB75N03HDL	A TMOSPRFET25V,0.009OHM	N	50	7.40	50	†
MTA4N50E	A TMOSPWR500V1.5 TO220FP	N	50	2.74	50	†	MTB75N03HDLT4	A TMOSPWR FET T/R	N	800	7.50	800	†
MTA4N60E	A TMOSPWR1.2R600V TO220FP	2	50	4.24	50	†	MTB75N05HD	A TMOSPWR FET75A50V	2	50	6.40	50	†
MTA5N50E	A TMOSPWR500V.8R TO220FP	2	50	4.16	50	†	MTB75N05HDT4	A TMOSPWR FET75A50V T/R	2	800	6.46	800	†
MTB1N100E	A TMOSPWR FET1000V9.00OH	N	50	3.26	50	†	MTB75N06HD	A TMOSPWR FET60V,00.01OHM	N	50	6.48	50	†
MTB10N40E	A FET TMOSPWR	2	50	3.68	50	†	MTB75N06HDT4	A TMOSPWR FET60V,00.01OHM	N	800	6.54	800	†
MTB15N06V	A TMOSV FET,60V,.120 OHMS	N	50	1.40	50	†	MTB8N50E	A TMOSPWR0.8R500V D2PAK	2	50	3.64	50	†
MTB15N06VT4	A TMOSV FET,60V,.120 OHMS	N	800	1.50	800	†	MTB8N50ET4	A TMOSPWR0.8R500V D2PAK	2	800	3.64	800	S †
MTB16N25E	A TMOSPWR FET250V,0.25OHM	N	50	2.50	50	†	MTDF1N02HDR2	A MICRO-8,20V,1.7A,120MOHM	2	4000	.75	4000	†
MTB2P50E	A TMOSPWR FET500V6.00OHM	N	50	2.90	50	†	MTDF1N03HDR2	A MICRO-8,30V,1.7A,120MOHM	2	4000	.75	4000	†
MTB2P50ET4	A TMOSPWR FET500V6.00OHM	2	800	1.60	800	†	MTDF1P02HDR2	A MICR-8,20V,1.6A,175MOHMS	2	4000	.80	4000	†
MTB20N20E	A TMOSPWR NCHAN	N	50	5.50	50	†	MTD1N50E	A TMOSPWR FET500V	N	75	1.28	75	†
MTB20N20ET4	A TMOSPWR NCHAN	N	800	5.54	800	†	MTD1N50ET4	A TMOSPWR FET500V	N	2500	.81	2500	†
MTB23P06V	A TMOSPWR FET XSTR	N	50	2.90	50	†	MTD1N50E1	A TMOSPWR FET500V	N	75	1.30	75	†

A = OSPD/Power
 B = Analog/Logic
 J = Transportation
 L = Consumer
 N = Networking
 V = Wireless

S = Proprietary Device
 B = Motorola Blue Chip Program Device
 P = Phoenix Program
 * = First Time in Book
 † \$200 Minimum Waived

N = Key New Motorola Device
 R = Key "Focus" Motorola Device

1 = Mature, Stable, High-Volume Device
 2 = Moderate-Volume Device
 3 = Low-Volume Device

EFFECTIVE DATE: JANUARY 10, 1998

COMMERCIAL COMPONENTS

Type No.	Grp/Description	Per Unit Sugg. Factory					
		Resale Price	Price	Order			
PC	Qty			Incrmnt			
MTD1N60E	A TMOSPWR FET600V8.00OHM	N	75	1.70	75	S	†
MTD1N60ET4	A TMOSPWR FET600V8.00OHM	N	2500	1.09	2500		†
MTD1N60E1	A TMOSPWR FET600V8.00OHM	N	75	1.72	75		†
MTD1N80E	A TMOSPWF FET800V,12OHM	N	75	2.18	75	S	†
MTD1N80ET4	A TMOSPWF FET300V,12.00OHM	N	2500	1.39	2500		†
MTD1N80E1	A TMOSPWF FET800V,12.00OHM	N	75	2.20	75		†
MTD10N10EL	A TMOSPWR FET	N	75	1.56	75		†
MTD1302	A TMOSFET,30V,0.022OHMS	N	75	1.20	75		†
MTD15N06V	A TMOSVF FET60V,0.120OHMS	N	75	1.10	75		†
MTD15N06VT4	A TMOSVF FET60V,0.120OHMS	N	2500	1.16	2500		†
MTD2N40E	A TMOSPWR FET500V,3.50OHM	N	75	1.32	75		†
MTD2N40ET4	A TMOSPWR FET500V,3.50OHM	N	2500	.84	2500		†
MTD2N50E	A TMOSPWR FET500V4 OHMS	N	75	1.52	75		†
MTD2N50ET4	A TMOSPWR FET500V4 OHMS	N	2500	.96	2500		†
MTD2N50E1	A TMOSPWR FET500V4 OHMS	N	75	1.58	75		†
MTD20N03HDL	A TMOSPWR FET30V,0.035	R	75	1.30	75		†
MTD20N03HDLT4	A TMOSPWR FET30V,0.035	N	2500	.79	2500	S	†
MTD20N06HD	A TMOSPWR FET60V,0.045OHM	R	75	1.74	75	S	†
MTD20N06HDL	A TMOSPWR FET60V,0.045OHM	R	75	1.20	75		†
MTD20N06HDLT4	A TMOSPWR FET60V,0.045OHM	N	2500	1.24	2500		†
MTD20N06HDT4	A TMOSPWR FET60V,0.045OHM	N	2500	1.12	2500	S	†
MTD20P03HDL	A TMOSDPAK PCHAN	R	75	1.50	75		†
MTD20P03HDLT4	A TMOSDPAK PCHAN	N	2500	.89	2500		†
MTD20P06HDL	A TMOS,60V,0.175 OHM	N	75	2.24	75		†
MTD2955E	A TMOSPWR60V.3R DPAK	1	75	1.24	75		†
MTD2955ET4	A TMOSDPAK PCHAN	1	2500	.85	2500		†
MTD2955E1	A TMOSDPAK PCHAN	2	75	1.40	75		†
MTD2955V	A PWR XSTR,60V,0.200OHMS	N	75	1.20	75		†
MTD2955VT4	A PWR XSTR,60V,0.200OHMS	N	2500	.68	2500		†
MTD2955V1	A PWR XSTR,60V,0.200OHMS	N	75	1.30	75		†
MTD3055E	A TMOSPWR60V.15R DPAK	2	75	1.90	75		†
MTD3055EL	A TMOSPWR60V.18R DPAK	1	75	1.08	75		†
MTD3055EL1	A TMOSPWR60V.18R DPAK	2	75	1.08	75		†
MTD3055ERL	A REEL PACK FOR MTD3055E	2	1800	.94	1800		†
MTD3055ET4	A TMOSPWR60V.15R DPAK T/R	2	2500	.63	2500		†
MTD3055E1	A TMOSPWR60V.15R DPAK	2	75	.90	75		†
MTD3055V	A TMOSPWR FET60V,0.15OHM	N	75	.80	75		†
MTD3055VL	A TMOSPWR FET60V,0.18OHM	N	75	1.08	75		†
MTD3055VLT4	A TMOSPWR FET60V,0.18OHM	2	2500	.83	2500		†
MTD3055VL1	A TMOSPWR FET60V,0.18OHM	1	75	1.08	75		†
MTD3055VT4	A TMOSPWR FET60V,0.15OHM	N	2500	.86	2500		†
MTD3055V1	A TMOSPWR FET60V,0.15OHM	N	75	.80	75		†
MTD4N20E	A TMOSFET1.2 OHMS200V	N	75	1.16	75		†
MTD4N20ET4	A TMOSFET1.2 OHMS200V	N	2500	.73	2500		†
MTD4N20E1	A TMOSFET1.2 OHMS200V	N	75	1.18	75		†

Type No.	Grp/Description	Per Unit Sugg. Factory					
		Resale Price	Price	Order			
PC	Qty			Incrmnt			
MTD5N25E	A TMOSPWR FET250V1.00OHM	N	75	1.50	75		†
MTD5N25ET4	A TMOSPWR FET250V1.00OHM	N	2500	.92	2500		†
MTD5N25E1	A TMOSPWR FET250V1.00OHM	N	75	1.52	75		†
MTD5P06ET4	A TMOSPWR FET60V,0.55 OHM	2	2500	1.26	2500		†
MTD5P06V	A TMOSPWR FET60V0.45 OHM	N	75	.78	75		†
MTD5P06VT4	A TMOSPWR FET60V0.45 OHM	2	2500	.60	2500		†
MTD5P06V1	A TMOSPWR FET60V0.45 OHM	N	75	.84	75		†
MTD6N10E	A TMOSPWR FRT XSTR	N	75	1.10	75		†
MTD6N10ET4	A TMOSPWR FRT XSTR	N	2500	.63	2500		†
MTD6N15	A TMOSPWR150V.3R DPAK	3	75	2.24	75		†
MTD6N15T4	A TMOSPWR150V.3R DPAK	2	2500	.83	2500		†
MTD6N20E	A TMOSPWR FET200V,0.70OHM	N	75	1.30	75		†
MTD6N20ET4	A TMOSPWR FET200V,0.70OHM	N	2500	.76	2500		†
MTD6N20E1	A TMOSPWR FET200V,0.70OHM	N	75	1.30	75		†
MTD6P10E	A TMOSPWR FET100V0.66OHM	N	75	2.04	75		†
MTD6P10ET4	A TMOSPWR FET100V0.66OHM	N	2500	1.31	2500		†
MTD6P10E1	A TMOSPWR FET100V0.66OHM	N	75	2.06	75		†
MTD9N10E	A TMOSPWR0.25R100V DPAK	2	75	1.18	75		†
MTD9N10ET4	A TMOSPWR0.25R100V DPAK	2	2500	.77	2500		†
MTD9N10E1	A TMOSPWR0.25R100V DPAK	2	75	1.26	75		†
MTE125N20E	A TMOSISOTOP200V-0.015R	N	10	50.00	10		†
MTE215N10E	A TMOSISOTOP100V-0.0055R	N	10	51.00	10		†
MTE53N50E	A TMOSISOTOP500V-0.080R	N	10	52.00	10		†
MTP1N100E	A TMOSPWR FET1000V9.00OH	N	50	3.90	50		†
MTP1N50E	A TMOSPWR FET500V,6.00OHM	N	50	.90	50		†
MTP1N60E	A TMOSPWR FET600V8 OHMS	1	50	.96	50		†
MTP10N10E	A TMOSPWR100V.25R TO220	1	50	.75	50		†
MTP10N10EL	A TMOSPWR FET	N	50	1.60	50		†
MTP10N40E	A TMOSPWR400V.55R TO220	1	50	2.72	50		†
MTP12N10E	A TMOSPWR0.16R100V TO220	1	50	1.04	50		†
MTP12P10	A TMOSPWR100V.30R TO220	1	50	2.40	50		†
MTP15N05EL	A TMOSPWR FET15A50V	1	50	1.36	50		†
MTP15N06E	A TMOSPWR60V.15R TO220	2	50	1.20	50		†
MTP15N06V	A TMOSVF FET,60V,120OHMS	1	50	.92	50		†
MTP15N06VL	A TMOSPWR FET,60V,0.085OHM	N	50	.80	50		†
MTP16N25E	A TMOSPWR FET	N	50	2.40	50		†
MTP2N40E	A TMOSPWR FET400V3.50 OH	N	50	1.40	50		†
MTP2N50E	A TMOSPWR FET500V,3.60OHM	N	50	1.60	50		†
MTP2N60E	A TMOSPWR3.8R600V TO220	2	50	1.58	50		†
MTP2P50E	A TMOSPWR FET500V,6.00OHM	1	50	2.80	50		†
MTP20N06V	A TMOSVPWR,60V,0.080OHMS	N	50	1.08	50		†
MTP20N20E	A TMOSPWR FET200V	1	50	3.50	50		†
MTP23P06	A TMOSPWR0.12R60VP-CHAN	2	50	2.90	50		†
MTP23P06V	A TMOSPWR FET XSTR	1	50	1.50	50		†
MTP27N10E	A TMOSPWR FET	1	50	1.54	50		†

A = OSPD/Power
 B = Analog/Logic
 J = Transportation
 L = Consumer
 N = Networking
 V = Wireless

S = Proprietary Device
 B = Motorola Blue Chip Program Device
 P = Phoenix Program
 * = First Time in Book
 † \$200 Minimum Waived

N = Key New Motorola Device
 R = Key "Focus" Motorola Device

1 = Mature, Stable, High-Volume Device
 2 = Moderate-Volume Device
 3 = Low-Volume Device

COMMERCIAL COMPONENTS

Type No.	Grp/Description	Per Unit Sugg. Factory				Type No.	Grp/Description	Per Unit Sugg. Factory					
		PC	Qty	Price	Order			PC	Qty	Price	Order		
MTP2955E	A TMOSPWR60V,12AP-CHAN	1	50	1.56	50	†	MTV10N100E	A PWRMOSFET TO3N-CHAN	N	30	16.70	30	†
MTP2955V	A PWRXSTR,60V,0.2000HMS	N	50	1.20	50	†	MTV16N50E	A N-CHAN TMOSPWR FET	N	30	5.20	30	†
MTP3N100E	A TMOSPWR1000V4.0R TO220	1	50	3.40	50	†	MTV20N50E	A N-CHAN, TMOSPWR FET	N	30	14.80	30	†
MTP3N120E	A PWR,FETXSTR,1200V,5 OHMS	N	50	4.00	50	†	MTV32N20E	A TMOSPOWERFET	N	30	7.50	30	†
MTP3N50E	A TMOSPWR500V3.0R TO220	2	50	1.40	50	†	MTV32N25E	A TMOSN-CHAN0.08R,250V	N	30	11.80	30	†
MTP3N60E	A TMOSPWR600V,5R TO220	2	50	1.98	50	†	MTV6N100E	A N-CHAN TMOSPWR FET	N	30	12.50	30	†
MTP30N06EL	A TMOSPWR0.050R60V TO220	2	50	2.58	50	†	MTW10N100E	A TMOSPWR1.2R1000V TO247	N	30	12.91	30	†
MTP30N06VL	A TMOSPWR FET60V0.05 OHM	N	50	1.70	50	†	MTW14N50E	A TMOSPWR0.32R500V TO247	2	30	4.30	30	†
MTP30P06V	A TMOS,PWRXSTR,60V,.08 OHM	N	50	1.67	50	†	MTW16N40E	A TMOSPWR0.24R400V TO247	2	30	4.80	30	†
MTP3055EL	A TMOSPWR60V.18R TO220	1	50	1.12	50	†	MTW20N20E	A TMOSTO247	2	30	6.10	30	†
MTP3055V	A TMOSPWR FET60V,0.15OHM	1	50	.70	50	†	MTW20N50E	A TMOSPWR0.24R500V TO247	N	30	7.00	30	†
MTP3055VL	A TMOSPWR FET	1	50	.84	50	†	MTW24N40E	A TMOSPWR0.16R400V TO247	N	30	7.60	30	†
MTP33N10E	A SPP PWRNCHAN	N	50	4.60	50	†	MTW32N20E	A TMOSPWR0.075R200V TO247	2	30	7.04	30	†
MTP36N06E	A TMOSPWR0.04R60V TO220	2	50	1.84	50	†	MTW32N25E	A TMOSPWR0.08R250V TO247	N	30	7.60	30	†
MTP36N06V	A TMOSPWR FET	1	50	1.42	50	†	MTW35N15E	A TMOS0.05R150V TO247	2	30	7.04	30	†
MTP4N40E	A TMOSPWR1.8R400V TO220	2	50	1.28	50	†	MTW45N10E	A TMOS0.035R100V TO247	2	30	7.04	30	†
MTP4N50E	A TMOSPWR500V1.5R TO220	1	50	1.90	50	†	MTW6N100E	A TMOSPWR1.5R1000V TO247	N	30	11.50	30	†
MTP4N80E	A TMOSPWR FET,800V,3.00HM	2	50	4.02	50	†	MTW7N80E	A TMOSPWR1R800V TO247	N	30	9.26	30	†
MTP5N40E	A TMOSPWR400V1.0R TO220	1	50	1.90	50	†	MTW8N60E	A TMOSPWR0.5R600V TO247	N	30	4.50	30	†
MTP5P25	A TMOSPWR250V3.0R TO220	N	50	2.20	50	†	MTY100N10E	A PWR TMOS TO-3PBLN-CHAN	N	25	23.38	25	†
MTP50N05E	A TMOSPWR50V.028R TO220	1	50	2.40	50	†	MTY14N100E	A TMOSPWR FET	N	25	20.00	25	†
MTP50N05EL	A TMOSPWR50V.032R TO220	2	50	2.88	50	†	MTY25N60E	A PWRMOSFET TO-3NCHAN LN	N	25	26.66	25	S †
MTP50N06E	A TMOSPWR60V0.025R TO220	2	50	2.40	50	†	MTY30N50E	A PWRMOSFET	1	25	25.32	25	S †
MTP50N06EL	A TMOSPWR0.028R60V TO220	2	50	3.00	50	†	MTY55N20E	A PWR TMOS TO-3PBLN-CHAN	N	25	24.82	25	S †
MTP50N06V	A TMOS V FET,60V,.028 OHM	1	50	1.63	50	†	MUN2111T1	A BIAS RESISTOR XSTR	2	3000	.12	3000	†
MTP50N06VL	A TMOS V FET,60V,.032 OHM	N	50	2.00	50	†	MUN2116T1	A BIAS RESISTOR TRANS	2	3000	.12	3000	†
MTP50P03HDL	A TMOSP/FET30V,25MILLIOHM	R	50	5.70	50	†	MUN2211T1	A BIAS RESISTOR XSTR	2	3000	.12	3000	†
MTP52N06V	A TMOS V PWR,60V,0.022 OHMS	N	50	1.83	50	†	MUN2212T1	A BIAS RESISTOR XSTR	2	3000	.12	3000	†
MTP52N06VL	A TMOS V PWR,60V,0.025 OHMS	N	50	3.17	50	†	MUN2213T1	A BIAS RESISTOR XSTR	2	3000	.12	3000	†
MTP6N60E	A TMOSPWR600V1.2R TO220	1	50	4.00	50	†	MUN2216T1	A BIAS RESISTOR TRANS	2	3000	.14	3000	†
MTP6P20E	A TMOSPOWER TO220	2	50	2.60	50	†	MUN5111DW1T1	A DUBIAS RES XSTR SOT-363	N	3000	.16	3000	†
MTP60N06HD	A TMOSPWR FET60V,0.014OHM	N	50	4.50	50	†	MUN5115DW1T1	A DUBIAS RES XSTR SOT-363	N	3000	.16	3000	†
MTP7N20	A TMOSPWR200V.70R TO220	3	50	2.24	50	†	MUN5116DW1T1	A BIAS RES XSTR SOT-363	N	3000	.16	3000	†
MTP7N20E	A TMOS200V0.7R TO220	N	50	1.40	50	†	MUN5211DW1T1	A XSTR SOT-363/SC70 NPN	N	3000	.16	3000	†
MTP75N03HDL	A TMOSPR FET25V,0.009 OHM	R	50	7.10	50	†	MUN5215DW1T1	A DUALBIAS RES XSTR SOT363	N	3000	.16	3000	†
MTP75N05HD	A TMOSPWR FET75A50V	1	50	6.42	50	†	MUN5311DW1T1	A BIAS RES XSTR SOT-363	N	3000	.16	3000	†
MTP75N06HD	A TMOSPR FET60V,0.0095OHM	R	50	6.48	50	†	MUN5312DW1T1	A DUBIAS RES XSTR SOT-363	N	3000	.16	3000	†
MTP8N20	A TMOSPWR200V.40R TO220	2	50	1.56	50	†	MUN5314DW1T1	A BIAS RES XSTR SOT-363	N	3000	.16	3000	†
MTP8N50E	A TMOSPWR500V.8R TO220	1	50	2.64	50	†	MUN5316DW1T1	A XSTR SOT-363	N	3000	.16	3000	†
MTP9N25E	A TMOSPWR FET	N	50	1.50	50	†	MURB1620CT	A REC16A200V UFRD2PAK	N	50	1.60	50	†
MTSF1P02HDR2	A MOSFET,1.8A,20V,160MOHM	N	4000	.80	4000	†	MURB1620CTT4	A REC16A200V UFRD2PAK	N	800	1.32	800	†
MTSF2P02HDR2	A MICRO-8,20V,2.4A,90MOHM	2	4000	.83	4000	†	MURB1660CT	A REC16A600V UFRD2PAK	N	50	3.30	50	†
MTSF2P03HDR2	A MICRO-8,30V,2.4A,90MOHMS	2	4000	.80	4000	†	MURB1660CTT4	A REC16A600V UFRD2PAK	N	800	2.64	800	†
MTSF3N02HDR2	A MICRO-8,20V,3.8A,40MOHM	2	4000	.77	4000	†	MURD310T4	A REC3A100V UFR DPAK	2	2500	.66	2500	†
MTSF3N03HDR2	A MICRO-8,30V,3.7A,40MOHMS	N	4000	.80	4000	†	MURD315T4	A REC3A150V UFR DPAK	2	2500	.67	2500	†

A = OSPD/Power
 B = Analog/Logic
 J = Transportation
 L = Consumer
 N = Networking
 V = Wireless

S = Proprietary Device
 B = Motorola Blue Chip Program Device
 P = Phoenix Program
 * = First Time in Book
 † \$200 Minimum Waived

N = Key New Motorola Device
 R = Key "Focus" Motorola Device

1 = Mature, Stable, High-Volume Device
 2 = Moderate-Volume Device
 3 = Low-Volume Device

EFFECTIVE DATE: JANUARY 10, 1998

COMMERCIAL COMPONENTS

Type No.	Grp/Description	Per Unit Sugg.		Factory Order		
		Resale Price	Price			
PC	Qty		Incrmnt			
MURD320T4	A REC3A200V UFR DPAK	2	2500	.70	2500	†
MURD610CTT4	A REC6A100V ULTRAF DPKT/R	2	2500	.74	2500	†
MURD620CT	A REC6A200V ULTRAF DPAK	2	75	1.10	75	†
MURD620CTT4	A REC6A200V ULTRAF DPKT/R	2	2500	.80	2500	†
MURD620CT1	A REC6A200V ULTRAF DPAK	N	75	.80	75	†
MURF1620CT	A REC16A200V UFR220FP	2	50	1.76	50	†
MURF1660CT	A REC16A600V UFR220FP	N	50	2.82	50	†
MURF820	A REC8A200V UFR220FP	N	50	1.68	50	†
MURHB840CT	A REC8A400V UFRD2PAK	N	50	3.40	50	†
MURHB840CTT4	A REC8A400V UFRD2PAK	N	800	2.56	800	†
MURH840CT	A REC8A400V UFR220MHZ	2	50	3.20	50	†
MURH860CT	A REC8A600V UFR220MHZ	1	50	3.60	50	†
MURP20020CT	A REC200A200V UFR PTII	1	25	35.50	25	†
MURP20040CT	A REC200A400V UFR PTII	1	25	40.50	25	†
MURS105T3	A REC1A50V UFR SMB	2	2500	.50	2500	†
MURS110T3	A REC1A100V UFR SMB	1	2500	.50	2500	†
MURS115T3	A REC1A150V ULTRAF SRF MT	2	2500	.50	2500	†
MURS120T3	A REC1A200V UFR SMB	1	2500	.50	2500	†
MURS130T3	A REC1A300V UFR SMB	3	2500	1.56	2500	†
MURS140T3	A REC1A400V UFR SMB	1	2500	.56	2500	†
MURS150T3	A REC1A500V UFR SMB	3	2500	1.72	2500	†
MURS160T3	A REC1A600V UFR SMB	1	2500	.67	2500	†
MURS320T3	A REC3A200V UFR SMC	1	2500	.83	2500	†
MURS340T3	A REC3A400V UFR SMC	2	2500	.86	2500	†
MURS360T3	A REC3A600V UFR SMC	2	2500	.96	2500	†
MUR10120E	A REC10A1200V UFR220	N	50	6.72	50	†
MUR10150E	A REC10A1500V UFR220	2	50	7.70	50	†
MUR105	A REC1A50V ULTRAF AXIAL	2	1000	.36	1000	†
MUR105RL	A REC1A50V ULTRAF AXIAL	2	5000	.36	5000	†
MUR110	A REC1A100V ULTRAF AXIAL	1	1000	.36	1000	†
MUR110RL	A REC1A100V ULTRAF AXIAL	1	5000	.36	5000	†
MUR1100E	A REC1A1KV ULTRAF AXIAL	1	1000	.72	1000	†
MUR1100ERL	A REC1A1KV ULTRAF AXIAL	1	5000	.72	5000	†
MUR115	A REC1A150V ULTRAF AXIAL	1	1000	.36	1000	†
MUR115RL	A REC1A150V ULTRAF AXIAL	1	5000	.36	5000	†
MUR120	A REC1A200V ULTRAF AXIAL	1	1000	.36	1000	†
MUR120RL	A REC1A200V ULTRAF AXIAL	1	5000	.36	5000	†
MUR130	A REC1A300V ULTRAF AXIAL	2	1000	.50	1000	†
MUR130RL	A REC1A300V ULTRAF AXIAL	2	5000	.50	5000	†
MUR140	A REC1A400V ULTRAF AXIAL	1	1000	.50	1000	†
MUR140RL	A REC1A400V ULTRAF AXIAL	2	5000	.50	5000	†
MUR150	A REC1A500V ULTRAF AXIAL	2	1000	.50	1000	†
MUR1510	A REC15A100V ULTRAF T0220	2	50	1.80	50	†
MUR1515	A REC15A150V ULTRAF T0220	1	50	1.80	50	†
MUR1520	A REC15A200V ULTRAF T0220	1	50	1.80	50	†

Type No.	Grp/Description	Per Unit Sugg.		Factory Order		
		Resale Price	Price			
PC	Qty		Incrmnt			
MUR1540	A REC15A400V ULTRAF T0220	1	50	2.10	50	†
MUR1550	A REC15A500V ULTRAF T0220	2	50	3.00	50	†
MUR1560	A REC15A600V ULTRAF T0220	1	50	2.20	50	†
MUR160	A REC1A600V ULTRAF AXIAL	1	1000	.57	1000	†
MUR160RL	A REC1A600V ULTRAF AXIAL	1	5000	.57	5000	†
MUR1610CT	A REC16A100V ULTRAF T0220	1	50	1.30	50	†
MUR1610CTR	A REC16A100V UFR220A/C	2	50	2.70	50	†
MUR1615CT	A REC16A150V ULTRAF T0220	1	50	1.30	50	†
MUR1620CT	A REC16A200V ULTRAF T0220	1	50	1.30	50	†
MUR1620CTR	A REC16A200V UFR220A/C	1	50	2.70	50	†
MUR1640CT	A REC16A400V ULTRAF T0220	1	50	2.84	50	†
MUR1650CT	A REC16A500V ULTRAF T0220	2	50	2.92	50	†
MUR1660CT	A REC16A600V ULTRAF T0220	2	50	3.20	50	†
MUR180E	A REC1A800V ULTRAF AXIAL	2	1000	.57	1000	†
MUR190E	A REC1A900V ULTRAF AXIAL	2	1000	.64	1000	†
MUR3020PT	A REC30A200V ULTRAF T0218	1	30	4.20	30	†
MUR3040	A REC30A400V UFR T0218	3	30	6.82	30	†
MUR3040PT	A REC30A400V ULTRAF T0218	1	30	4.50	30	†
MUR3060PT	A REC30A600V ULTRAF T0218	1	30	5.30	30	†
MUR3060WT	A REC30A600V UFR247	2	30	4.20	30	†
MUR3080	A REC30A800V UFR218	2	30	4.80	30	†
MUR405	A REC4A50V ULTRAF AXIAL	2	500	.53	500	†
MUR410	A REC4A100V ULTRAF AXIAL	1	500	.53	500	†
MUR410RL	A REC4A100V ULTRAF AXIAL	2	1500	.49	1500	†
MUR4100E	A REC4A1000V ULTRAF AXIAL	1	500	1.07	500	†
MUR4100ERL	A REC4A1000V ULTRAF AXIAL	2	1500	.99	1500	†
MUR415	A REC4A150V ULTRAF AXIAL	1	500	.53	500	†
MUR415RL	A REC4A150V ULTRAF AXIAL	2	1500	.49	1500	†
MUR420	A REC4A200V ULTRAF AXIAL	1	500	.53	500	†
MUR420RL	A REC4A200V ULTRAF AXIAL	2	1500	.49	1500	†
MUR460	A REC4A600V ULTRAF AXIAL	1	500	.68	500	†
MUR460RL	A REC4A600V ULTRAF AXIAL	1	1500	.63	1500	†
MUR480E	A REC4A800V ULTRAF AXIAL	2	500	1.24	500	†
MUR480ERL	A REC4A800V ULTRAF AXIAL	3	1500	3.07	1500	†
MUR490E	A REC4A900V ULTRAF AXIAL	2	500	1.32	500	†
MUR6040	A REC60A400V ULTRAF T0218	2	30	7.00	30	†
MUR620CT	A REC6A200V ULTRAF T0220	2	50	2.10	50	†
MUR805	A REC8A50V ULTRAF T0220	2	50	1.04	50	†
MUR810	A REC8A100V ULTRAF T0220	1	50	1.04	50	†
MUR8100E	A REC8A1000V ULTRA T0220	1	50	3.14	50	†
MUR815	A REC8A150V ULTRAF T0220	1	50	1.04	50	†
MUR820	A REC8A200V ULTRAF T0220	1	50	1.04	50	†
MUR840	A REC8A400V ULTRAF T0220	1	50	1.18	50	†
MUR860	A REC8A600V ULTRAF T0220	1	50	1.28	50	†
MUR880E	A REC8A800V ULTRA T0220	1	50	3.60	50	†

A = OSPD/Power
 B = Analog/Logic
 J = Transportation
 L = Consumer
 N = Networking
 V = Wireless

S = Proprietary Device
 B = Motorola Blue Chip Program Device
 P = Phoenix Program
 * = First Time in Book
 † = \$200 Minimum Waived

N = Key New Motorola Device
 R = Key "Focus" Motorola Device

1 = Mature, Stable, High-Volume Device
 2 = Moderate-Volume Device
 3 = Low-Volume Device

EFFECTIVE DATE: JANUARY 10, 1998

COMMERCIAL COMPONENTS

Type No.	Grp/Description	Per PC	Unit Qty	Sugg. Resale Price	Factory Order	Incrrmnt	Type No.	Grp/Description	Per PC	Unit Qty	Sugg. Resale Price	Factory Order	Incrrmnt
MVAM108	A LAST ORDERDATE:08/02/98	2	1000	.78	1000	†	MZP4746ARL	A REEL PACK FOR MZP4746A	2	6000	.31	6000	S †
MVAM109	A LAST ORDERDATE:08/02/98	2	1000	.78	1000	†	MZP4749ARL	A REEL PACK FOR MZP4749A	2	6000	.31	6000	S †
MVAM115	A LAST ORDERDATE:08/02/98	1	1000	.78	1000	†	MZP4750ARL	A REEL PACK FOR MZP4750A	2	6000	.31	6000	S †
MVAM125	A LAST ORDERDATE:08/02/98	2	1000	.78	1000	†	MZP4751ARL	A REEL PACK FOR MZP4751A	2	6000	.31	6000	S †
MV104	A SSDLFM TUNING DIODE UNT	2	1000	.64	1000	†	MZ4099	A LAST ORDER DATE:03/15/98	3	3000	.64	3000	†
MV104RLRA	A REEL PACK FOR MV104	2	2000	.64	2000	†	MZ4099RL	A LAST ORDER DATE:03/15/98	3	5000	.68	5000	†
MV1403	A LAST ORDERDATE:09/20/98	2	200	8.82	200	†	MZ4101	A LAST ORDER DATE:03/15/98	3	3000	.64	3000	†
MV1404	A LAST ORDERDATE:09/20/98	1	200	8.82	200	†	MZ4104	A LAST ORDER DATE:03/15/98	3	3000	.64	3000	†
MV1405	A LAST ORDERDATE:09/20/98	2	200	8.82	200	†	MZ4104RL	A LAST ORDER DATE:03/15/98	2	5000	.30	5000	†
MV1628	A LAST ORDERDATE:09/20/98	3	200	6.05	200	†	MZ4614	A ZEN1.8V.25W5% DO35	2	3000	.28	3000	†
MV1630	A LAST ORDERDATE:09/20/98	3	200	6.06	200	†	MZ4615RL	A ZEN2.0V.25W5% DO35 T/R	2	5000	.30	5000	†
MV1634	A LAST ORDERDATE:09/20/98	3	200	6.06	200	†	MZ4616	A ZEN2.2V.25W5% DO35	3	3000	1.04	3000	†
MV1638	A LAST ORDERDATE:09/20/98	3	200	6.06	200	†	MZ4616RL	A ZEN2.2V.25W5% DO35 T/R	3	5000	.68	5000	†
MV1640	A LAST ORDERDATE:09/20/98	3	200	6.06	200	†	MZ4617	A ZEN2.4V.25W5% DO35	3	3000	.64	3000	†
MV1648	A LAST ORDERDATE:09/20/98	3	200	6.05	200	†	MZ4617RL	A ZEN2.4V.25W5% DO35 T/R	2	5000	.30	5000	†
MV209	A SS VHF TUNING DIODE UNIT	1	1000	.66	1000	†	MZ4618	A ZEN2.7V.25W5% DO35	3	3000	.64	3000	†
MV209RLRA	A REEL PACK FOR MV209	2	2000	.66	2000	†	MZ4618RL	A ZEN2.7V.25W5% DO35 T/R	3	5000	.68	5000	†
MV2101	A SSGEN PUR TUNING DIODE	2	1000	.74	1000	†	MZ4619	A ZEN3.0V.25W5% DO35	2	3000	.28	3000	†
MV2105	A SSGEN PUR TUNING DIODE	2	1000	.74	1000	†	MZ4619RL	A ZEN3.0V.25W5% DO35 T/R	3	5000	.68	5000	†
MV2105RLRA	A TUNING DIODE	2	2000	.74	2000	†	MZ4620	A ZEN3.3V.25W5% DO35	2	3000	.28	3000	†
MV2107	A LAST ORDERDATE:08/28/98	2	1000	.74	1000	†	MZ4620RL	A ZEN3.3V.25W5% DO35 T/R	2	5000	.30	5000	†
MV2108	A SSGEN PUR TUNING DIODE	2	1000	.74	1000	†	MZ4621	A ZEN3.6V.25W5% DO35	3	3000	.64	3000	†
MV2109	A SSGEN PUR TUNING DIODE	2	1000	.74	1000	†	MZ4621RL	A ZEN3.6V.25W5% DO35 T/R	3	5000	.68	5000	†
MV2109RLRA	A TUNING DIODE	2	2000	.74	2000	†	MZ4622	A ZEN3.9V.25W5% DO35	3	3000	.64	3000	†
MV2109RLRP	A TUNING DIODE AMMO/PACK	2	2000	.74	2000	†	MZ4622RL	A ZEN3.9V.25W5% DO35 T/R	2	5000	.30	5000	†
MV2111	A SSGEN PUR TUNING DIODE	2	1000	1.00	1000	†	MZ4623RL	A ZEN4.3V.25W5% DO35 T/R	2	5000	.30	5000	†
MV2115	A SSGEN PUR TUNING DIODE	2	1000	1.00	1000	†	MZ4624	A ZEN4.7V.25W5% DO35	2	3000	.28	3000	†
MV7005T1	A LAST ORDERDATE:09/20/98	N	1000	1.04	1000	†	MZ4624RL	A ZEN4.7V.25W5% DO35 T/R	3	5000	.68	5000	†
MV7005T3	A LAST ORDERDATE:09/20/98	N	4000	1.04	4000	†	MZ4625	A ZEN5.1V.25W5% DO35	2	3000	.28	3000	†
MV7404T1	A LAST ORDERDATE:09/20/98	2	1000	4.30	1000	†	MZ4625RL	A ZEN5.1V.25W5% DO35 T/R	2	5000	.30	5000	†
MWA110	N RFPWR AMPLIFIERTO-39	1	200	5.85	200		MZ4626	A ZEN5.6V.25W5% DO35	3	3000	.64	3000	†
MWA120	N RFPWR AMPLIFIERTO-39	1	200	5.93	200		MZ4626RL	A ZEN5.6V.25W5% DO35 T/R	3	5000	.68	5000	†
MWA130	N RFPWR AMPLIFIERTO-39	1	200	6.01	200		MZ4627	A ZEN6.2V.25W5% DO35	3	3000	.64	3000	†
MWA131	N RFPWR AMPLIFIERTO-39	2	200	8.47	200		MZ4627RL	A ZEN6.2V.25W5% DO35 T/R	3	5000	.68	5000	†
MWA220	N RFPWR AMPLIFIERTO-39	2	200	6.01	200		MZ5520B	A LAST ORDER DATE:03/15/98	3	3000	.64	3000	†
MWA230	N RFPWR AMPLIFIERTO-39	2	200	6.08	200		MZ5520BRL	A LAST ORDER DATE:03/15/98	3	5000	.68	5000	†
MWA320	N LAST ORDERDATE:05/10/98	2	200	6.08	200		MZ5521B	A LAST ORDER DATE:03/15/98	3	3000	.64	3000	†
MXR9745T1	V SOT89LV1.54-CELLDMOS	N	1000	3.00	1000		MZ5523B	A LAST ORDER DATE:03/15/98	3	3000	.64	3000	†
MZP4729ARL	A REEL PACK FORMZP4729A	2	6000	.32	6000	S †	MZ5523BRL	A LAST ORDER DATE:03/15/98	3	5000	.68	5000	†
MZP4735ARL	A REEL PACK FORMZP4735A	2	6000	.32	6000	S †	MZ5524B	A LAST ORDER DATE:03/15/98	3	3000	.64	3000	†
MZP4740ARL	A REEL PACK FORMZP4740A	2	6000	.31	6000	S †	MZ5524BRL	A LAST ORDER DATE:03/15/98	3	5000	.68	5000	†
MZP4741A	A ZENER DIODE	N	2000	.29	2000	S †	MZ5525B	A LAST ORDER DATE:03/15/98	3	3000	.64	3000	†
MZP4741ARL	A REEL PACK FORMZP4741A	2	6000	.31	6000	S †	MZ5525BRL	A LAST ORDER DATE:03/15/98	3	5000	.68	5000	†
MZP4742A	A ZENER DIODE	N	2000	.39	2000	S †	MZ5527B	A LAST ORDER DATE:03/15/98	3	3000	.64	3000	†
MZP4742ARL	A REEL PACK FORMZP4742A	2	6000	.31	6000	S †	M1MA141KT1	A SINGLE SW/DIO SC70 PKG	N	3000	.13	3000	†

- | | | | |
|--------------------|---------------------------------------|---------------------------------|--|
| A = OSPD/Power | S = Proprietary Device | N = Key New Motorola Device | 1 = Mature, Stable, High-Volume Device |
| B = Analog/Logic | B = Motorola Blue Chip Program Device | R = Key "Focus" Motorola Device | 2 = Moderate-Volume Device |
| J = Transportation | P = Phoenix Program | | 3 = Low-Volume Device |
| L = Consumer | * = First Time in Book | | |
| N = Networking | † = \$200 Minimum Waived | | |
| V = Wireless | | | |

COMMERCIAL COMPONENTS

Type No.	Grp/Description	Per Unit Sugg.		Factory Order	
		Resale Price	Price		
PC	Qty	Price	Incrmnt		
M5102EVM	L DEVELOPMENT BRD FOR5102	N	1	275.00	1
M5202EVM	L DEVELOPED BRD5202	N	1	495.00	1
M5202GW	L MCF5202 TOMC68EC000	N	1	99.00	1*
M5204AN	L DEVELOP. BOARD MCF5204	N	1	250.00	1
M5206AN	L DEVELOP. BOARD MCF5206	N	1	250.00	1
M68BCC331	J AMCU-EMULAT DAUGHTR BRD	N	1	319.20	1*
M68BCC332A	J AMCU-PLUGIN ASSMMC68332A	N	1	319.20	1*S
M68BCC332G	J AMCU-PLUGIN ASSMMC68332G	N	1	319.20	1*S
M68CBL05A	L FLEX CABLE A	N	1	120.00	1
M68CBL05B	L FLEX CABLE B	N	1	120.00	1
M68CBL05C	L FLEX CABLE C	N	1	120.00	1
M68CBL05D	L FLEX CABLE D	N	1	150.00	1*S
M68CBL05E	L FLEX CABLE E	N	1	150.00	1
M68CBL11B	L FLEX CABLE	N	1	120.00	1 S
M68CBL11C	L FLEX CABLE C	N	1	120.00	1 S
M68CBL11D	L FLEX CABLE D	N	1	150.00	1 S
M68CBL11E	L FLEX CABLE E	N	1	150.00	1 S
M68DIP16SOIC	L CSIC-16PINDIP-SOIC ADAP	N	1	35.00	1 S
M68DIP20SOIC	L CSIC-20PINDIP-SOIC ADAP	N	1	35.00	1
M68DIP28SOIC	L CSIC-28PINDIP-SOIC ADAP	N	1	35.00	1
M68EC000IDP	L EVALUATION PLATFORMS68EC	N	1	510.00	1 S
M68EC020IDP	L EVALUATION PLATFORMS68EC	N	1	595.00	1 S
M68EC030IDP3	L DEV.& EVALUATION FOR030	N	1	650.00	1 S
M68EC040IDP3	L DEV.& EVALUATION FOR040	N	1	750.00	1 S
M68EC060IDP	L EVALUATION BROAD FOR060	N	1	850.00	1
M68EML05L16	L HC05L16 EMULATOR KIT	N	1	295.00	1 S
M68EML05L26	L HC05L26 LV EMULATOR BOARD	N	1	295.00	1 S
M68EML05X32	L EMUL BRD LVHC(7)05X16/XX	N	1	295.00	1
M68EML08XL36	L CSIC MCU MOD68HC708XL36	N	1	295.00	1 S
M68EM05A24	L DEVELOPMENT TOOL PROD.	N	1	295.00	1 S
M68EM05BS8	L EMULATOR	N	1	295.00	1
M68EM05B32	L EMULATOR KIT	N	1	295.00	1
M68EM05CJ4	L HC05CJ4 EMULATOR BOARD	N	1	295.00	1 S
M68EM05CL4	L EMULATOR FOR MC68HC705CL4	N	1	295.00	1 S
M68EM05C9A	L EMULATOR KIT	N	1	295.00	1 S
M68EM05E6	L EMULATOR	N	1	295.00	1 S
M68EM05F6	L F6 MCU EMULATOR BOARD	N	1	295.00	1 S
M68EM05G1	L EMULATION MODULE	N	1	295.00	1 S
M68EM05G4	L HC05G4 EMULATOR KIT	N	1	295.00	1 S
M68EM05J1A	L CSIC-EVALUATION MODULE	N	1	295.00	1
M68EM05J3	L EMULATION MODULE	N	1	295.00	1 S
M68EM05K3	L CSIC-EVALUATION MODULE	N	1	295.00	1
M68EM05L1	L EMULATION MODULE	N	1	295.00	1
M68EM05P3	L EMULATOR KIT	N	1	295.00	1 S
M68EM05SR3	L SR3 EMULATOR BOARD	N	1	295.00	1 S

Type No.	Grp/Description	Per Unit Sugg.		Factory Order	
		Resale Price	Price		
PC	Qty	Price	Incrmnt		
M68EM05T7	L T7 MCU EMULATOR	N	1	295.00	1
M68EM05V8	L CSIC MCU MODULE68HC705V8	N	1	295.00	1 S
M68EM05X4	L EMULATOR BOARD FOR HC05X4	N	1	295.00	1
M68EM11D3	L AMCU-EMULATION MODULE	N	1	300.00	1 S
M68EM11E20	L EMULATOR BOARD	N	1	300.00	1 S
M68EM11F1	L AMCU-EMULATION MODULE	N	1	300.00	1 S
M68EM11G5	L EMUL BRD HC11G5/G7	N	1	300.00	1 S
M68EM11KA4	L AMCU-EMULATION MODULE	N	1	300.00	1 S
M68EM11K4	L AMCU-EMULATION MODULE	N	1	300.00	1 S
M68EM11L6	L AMCU-EMULATION MODULE	N	1	300.00	1 S
M68EM11PH8	L PH8 EMULATOR KIT	N	1	300.00	1*S
M68EM11P2	L AMCU-EMULATION MODULE	N	1	300.00	1 S
M68EV912B32	L MCTG DEV TOOLS	N	1	99.00	1 S
M68FMSINITBDX30	J MCTG DEV TOOLS	N	1	195.00	1 S
M68FMSTPASBXXX	J AMCU	N	1	526.68	1*
M68HC05BPGMR	L MCU PROGRAMMER	N	1	168.05	1
M68HC05D32EM	L HC05D32 EMUL BRD KIT	N	1	295.00	1
M68HC05L9EVM2	L EVALUATION MODULE	N	1	498.00	1
M68HC05PGMR	L 8-BIT MCU	N	1	168.05	1 S
M68HC05PGMR-002	L MCU PROGRAMMER	N	1	168.00	1
M68HC05P9EM	L AMCU-HC05P9 EVAL MODULE	N	1	295.00	1
M68HC05SCEM	L SMART CARD EMULATOR BOARD	N	1	295.00	1
M68HC05SR3PAB42	L PROGRAMMER42P SDIP BOARD	N	1	50.00	1 S
M68HC05SR3PAFB44	L PROGRAMMER44P QFP BOARD	N	1	150.00	1 S
M68HC05SR3PGMRSG	SR3 PROGRAMMER	N	1	250.00	1 S
M68HC05T2EVS	L HCO5 PLATFORM BRD&EMUL MO	N	1	498.00	1
M68HC05T4EVM	L EVALUATION MODULE	N	1	498.00	1
M68HC11EVB	L 68HC11 EVALUATION BOARD	1	1	199.00	1 S
M68HC11EVBU	L AMCU	N	1	175.00	1 S
M68HC11PFB	L 68HC11 PLATFORM BOARD	N	1	300.00	1 S
M68HC12A4EVB	J AMCU	N	1	412.00	1 S
M68HC705E6PGMR	L PROGRAMMER	N	1	168.00	1
M68HC705F6PGMR64	L I/C PROGRAMMING BOARD	N	1	68.05	1
M68HC705F8PGMR	L HC705F8 PROGRAMMER	N	1	68.05	1 S
M68HC705G1PGMR	L HC705G1 PROGRAMMER	N	1	68.05	1 S
M68HC705JICS	L CSIC-SIMULATR/PROGRAMMER	1	1	99.00	1
M68HC705J2PGMR	L 68HC705J2 PGRM BOARD	2	1	68.04	1 S
M68HC705K1GANG	L GANG PROGRAMMER-BOARD PDIP	N	1	300.00	1
M68HC705K1GANGY	L GANG PROGRAMMER-BOARD SOIC	N	1	600.00	1
M68HC705L1PGMR	L PROGRAMMING BOARD	N	1	68.00	1
M68HC705L2PGMR	L HC705L2 PROGRAMMER	N	1	168.05	1 S
M68HC705L5PGMR	L AMCU-PROGRAM FOR HC05L5	N	1	168.05	1
M68HC705P9PGMR	L 68HC705P9 PGRM BOARD	2	1	68.05	1 S
M68HC705T10PGMR	L 8BIT MCU	N	1	68.00	1
M68HC705T12PGMR	L PROGRAMMING BOARD	N	1	68.05	1 S

A = OSPD/Power
 B = Analog/Logic
 J = Transportation
 L = Consumer
 N = Networking
 V = Wireless

S = Proprietary Device
 B = Motorola Blue Chip Program Device
 P = Phoenix Program
 * = First Time in Book
 † \$200 Minimum Waived

N = Key New Motorola Device
 R = Key "Focus" Motorola Device

1 = Mature, Stable, High-Volume Device
 2 = Moderate-Volume Device
 3 = Low-Volume Device

COMMERCIAL COMPONENTS

Type No.	Grp/Description	PC	Qty	Per Resale Price	Sugg. Price	Factory Order Incrmt
M68HC705UPGMR	L MOTHER BOARD FOR HC05	N	1	350.00	1	S
M68HC705V8PGMR	L CSIC MCU PROGR68HC705V8	N	1	168.05	1	S
M68HC705X32PGMR	L TARGET HEAD KIT	N	1	168.00	1	S
M68HC705X4PGMR	L 705X4 PROGRAMMER	N	1	168.05	1	
M68HC805KICS	L CSIC MCU	N	1	168.05	1	S
M68ICD16	J AMCU-IN CIR DEBUG HC16 SER	2	1	149.50	1	S
M68ICD32	J AMCU-IN CIR DEBUG 300 SER	2	1	149.50	1	S
M68MMDS05	L MOD DEVE SYS M68HC05	1	1	2950.00	1	S
M68MMDS11	L AMCU-DEVELOPMENT SYSTEM	N	1	4950.00	1	S
M68MMDS1632	J AMCU-DEVELOPMENT SYSTEM	N	1	112500.00	1	S
M68MMPFB0508	L CSIC MCU PLATFROM BOARD	N	1	395.00	1	S
M68MPBF333C	J AMCU-PERSONAL BRD 68333	N	1	1095.00	1	★S
M68MPB16S2B	J AMCU	N	1	595.00	1	★S
M68MPB16Y1B	J AMCU-PERSONAL BRD HC16Y	N	1	500.00	1	S
M68MPB16Z1B	J AMCU-PERSONAL BRDS HC16Z	N	1	500.00	1	★S
M68MPB331B	J AMCU-PERSONAL BRD 68331	N	1	595.00	1	S
M68MPB332AB	J AMCU-PERSONBD 68332A DEV	N	1	595.00	1	S
M68MPB332GB	J AMCU-PERSONBD 68332G DEV	N	1	595.00	1	S
M68MPB334B	J AMCU-PLUGIN ASSEM M68334	N	1	595.00	1	S
M68MPB336GB	J AMCU-PERSONALITY BOARD	N	1	595.00	1	S
M68MPB376GB	J MCTG DEW TOOLS	N	1	595.00	1	S
M68MPB916X1C	J AMCU-MCU PERSONALITY BRD	N	1	500.00	1	S
M68MPFB1632	J AMCU-MODULAR PLATFORM BRD	N	1	750.00	1	S
M68PA11A8P48	L AMCU-PROGRAMMING ADAPTER	N	1	150.00	1	S
M68PA11D3FB44	L AMCU-PROGRAMMING ADAPTER	N	1	150.00	1	S
M68PA11D3FN44	L 44-LEAD PLCC D3 SPGMR	N	1	120.00	1	S
M68PA11D3P40	L 40-LEAD DIP D3 SPGMR ADAP	N	1	150.00	1	S
M68PA11E20FN52	L 52-LEAD PLCC E20 SPGMR	N	1	150.00	1	S
M68PA11E20FU64	L 64-LEAD QFP E20 SPGMR ADA	N	1	175.00	1	S
M68PA11E20PB52	L AMCU-PROGRAMMING ADAPTER	N	1	175.00	1	S
M68PA11F1FN68	L AMCU-PROGRAMMING ADAPTER	N	1	150.00	1	S
M68PA11F1PU80	L AMCU-PROGRAMMING ADAPTER	N	1	175.00	1	S
M68PA11G5FN84	L AMCU-PROGRAMMING ADAPTER	N	1	150.00	1	S
M68PA11KA4FN68	L 68-LEAD PLCC KA4 SPGMR	N	1	150.00	1	S
M68PA11KA4PU80	L MCTG DEV TOOLS	N	1	150.00	1	★S
M68PA11K4FN84	L AMCU-84 PIN PLCC PROG ADP	N	1	150.00	1	S
M68PA11K4FU80	L AMCU	N	1	150.00	1	S
M68PA11L6FN68	L 68-LEAD PLCC L6 SPGMR ADA	N	1	150.00	1	S
M68PA11L6FU64	L AMCU	N	1	175.00	1	★S
M68PA11PA8FN68	L AMCU-PROGRAMMING ADAPTER	N	1	150.00	1	S
M68PA11PH8FN84	L AMCU-PROGRAMMING ADAPTER	N	1	175.00	1	★S
M68PA11PH8PU100	L AMCU-PROGRAMMING ADAPTER	N	1	325.00	1	★S
M68PA11PH8PV112	L AMCU-PROGRAMMING ADAPTER	N	1	300.00	1	S
M68SC302ADS	N SC302 DEVELOPEMENT BOARD	N	1	795.00	1	S
M68SDEBUG12AB	J AMCU	N	1	150.00	1	S

Type No.	Grp/Description	PC	Qty	Per Resale Price	Sugg. Price	Factory Order Incrmt
M68SDIL	J AMCU	N	1	300.00	1	S
M68SDIL12	L SERIAL DEBUG INTERFACE	N	1	350.00	1	★S
M68SPGMR11	L HC11 SERIAL PROGRAMMER	N	1	250.00	1	S
M68TA05J2P20	L CSIC-TARGET HEAD ADAPTER	N	1	50.00	1	
M68TA05K1P16	L CSIC-TARET HEAD ADAPTER	N	1	35.00	1	
M68TA05P8P28	L CSIC-TARGET HEAD ADPATER	N	1	35.00	1	S
M68TA05P9P28	L CSIC-TARGET HEAD ADAPTER	N	1	35.00	1	
M68TA05X4P28	L TGT HD KIT - X4 IN DIP28	N	1	35.00	1	
M68TB05A24B56	L DEVELOPMENT TOOL PROD.	N	1	100.00	1	S
M68TB05BD7B42	L TARGETHAED FOR 42 PIN SDIP	N	1	100.00	1	S
M68TB05BD7P40	L TARGET HEAD FOR 40-PIN DIP	N	1	125.00	1	S
M68TB05BS8FN52	L TARGET HEADER FOR HC05BS8	N	1	125.00	1	S
M68TB05B32B56	L TARGET HEAD KIT	N	1	75.00	1	S
M68TB05C9B42	L TGT HD KIT - C9 IN SDIP42	N	1	100.00	1	S
M68TB05C9P40	L TGT HD KIT - C9 IN DIP40	N	1	50.00	1	
M68TB05F6B42	L SDIP42 ADAPTER BOARD	N	1	100.00	1	S
M68TB05G1B56	L M68HC05G1 CABLE ADAPTER	N	1	100.00	1	S
M68TB05L1B56	L M68HC05L1 CABLE ADAPTER	N	1	100.00	1	S
M68TB05SR3B42	L EM TARGET 42P SDIP BOARD	N	1	100.00	1	S
M68TB05SR3P40	L EM TARGET 40P DIP BOARD	N	1	100.00	1	S
M68TB05T7B56	L SDIP TARGET HEAD	N	1	100.00	1	S
M68TB05V8B56	L CSIC MCU ADAPTER 56SDIP	N	1	150.00	1	S
M68TB05V8FN68	L CSIC MCU ADAPTER 68PLCC	N	1	150.00	1	S
M68TB08XL36B56	L CSIC MCU 56SDIP 68HC7-08	N	1	100.00	1	S
M68TB11A8P48	J AMCU-HC11 ADAPT M68MMDS11	N	1	50.00	1	S
M68TB11E20B56	L AMCU-PROGRAMMING ADAPTER	N	1	50.00	1	S
M68TB11E20P48	L TARGET HEAD KIT	N	1	150.00	1	
M68TC05BS8FB44	L 44LD QFP TARGET HEADER	N	1	250.00	1	S
M68TC05B32FN52	L TARGET HEAD KIT	N	1	125.00	1	
M68TC05B32FU64	L TARGET HEAD KIT	N	1	250.00	1	
M68TC05C4FN44	L TGT HD KIT - C4 IN PLCC44	N	1	125.00	1	
M68TC05C9FB44	L TGT HD KIT - C9 IN QFP44	N	1	250.00	1	
M68TC05C9FN44	L TGT HD KIT - C9 IN PLCC44	N	1	125.00	1	
M68TC05E6FB44	L TARGET HEAD KIT	N	1	250.00	1	S
M68TC05F4FB44	L TARGET HEAD ADAPTER	N	1	250.00	1	S
M68TC05F4P28	L TARGET HEAD KIT	N	1	100.00	1	S
M68TC05F6FB44	L QFP44 ADAPTER BOARD	N	1	250.00	1	S
M68TC05F6FU64	L QFP64 ADAPTER BOARD	N	1	250.00	1	S
M68TC05G1FU64	L QFP ADAPTER BOARD	N	1	250.00	1	S
M68TC05L1FU64	L TARGET HEADER FOR HC05L1	N	1	250.00	1	S
M68TC05SR3FB44	L EM TARGET 44P QFP BOARD	N	1	250.00	1	S
M68TC11C0FU64	L AMCU-TARGET HEAD ADAPTER	N	1	250.00	1	S
M68TC11D3FB44	L AMCU-HC11 ADAPT M68MMDS11	N	1	250.00	1	★S
M68TC11D3FN44	L AMCU-HC11 ADAPT M68MMDS11	N	1	125.00	1	S
M68TC11D3P40	L AMCU-HC11 ADAPT M68MMDS11	N	1	50.00	1	S

A = OSPD/Power
 B = Analog/Logic
 J = Transportation
 L = Consumer
 N = Networking
 V = Wireless

S = Proprietary Device
 B = Motorola Blue Chip Program Device
 P = Phoenix Program
 ★ = First Time in Book
 † \$200 Minimum Waived

N = Key New Motorola Device
 R = Key "Focus" Motorola Device

1 = Mature, Stable, High-Volume Device
 2 = Moderate-Volume Device
 3 = Low-Volume Device

EFFECTIVE DATE: JANUARY 10, 1998

COMMERCIAL COMPONENTS

Type No.	Grp/Description	Per PC	Unit Qty	Sugg. Resale Price	Factory Order Incrmnt
M68TC11E20FN52	L TARGET HEADKIT	N	1	240.00	1 S
M68TC11E20FU64	L TARG HDKIT HC11E2064QFP	N	1	250.00	1 *S
M68TC11E20PB52	L AMCU-TARGET HEAD ADAPTER	N	1	250.00	1 S
M68TC11F1FN68	L AMCU-HC11 ADAPT M68MMDS11	N	1	150.00	1 S
M68TC11F1PU80	L AMCU-HC11 ADAPT M68MMDS11	N	1	300.00	1 *S
M68TC11KA4FN68	L AMCU-HC11 ADAPT M68MMDS11	N	1	150.00	1 *S
M68TC11KA4FU64	L TARGET HEAD KIT (AUTO)	N	1	250.00	1 *S
M68TC11L6FN68	L AMCU-HC11 ADAPT M68MMDS11	N	1	150.00	1 *S
M68TC11L6FU64	L AMCU-HC11 ADAPT M68MMDS11	N	1	250.00	1 *S
M68TD11G5FN84	L AMCU-TARGET HEAD ADAPTAR	N	1	150.00	1 S
M68TD11K4FN84	L AMCU-HC11 ADAPT M68MMDS11	N	1	150.00	1 S
M68TD11PH8FN84	L TARGET HEADKIT	N	1	150.00	1 S
M68TD11PH8PU100	L AMCUADAP68HC11PH8PU100	N	1	300.00	1 S
M68TE05CL4FU80	L TARGET HEAD FOR80-PIN QFP	N	1	300.00	1 S
M68TE05F32FU100	L TARGET HEADKIT	N	1	300.00	1 S
M68TE05F32FU80	L TARGET HEADKIT	N	1	300.00	1 S
M68TE05G4FU80	L 80QFP TARGET HEAD ADAPTER	N	1	300.00	1 S
M68TE05L16FU80	L HC05L16 TARGET HEAD	N	1	300.00	1 S
M68TE05X32FU64	L TARGET HEADKIT	N	1	250.00	1
M68TE11K4FU80	L AMCU-HC11 ADAPT M68MMDS11	N	1	300.00	1 S
M68TQP032SA1	L CSIC-32PIN TQPACK	N	1	70.00	1 *S
M68TQP044SAMO1	L CSIC MCU44PIN TQPACK	N	1	70.00	1 *S
M68TQP044SA1	L CSIC MCU44PIN TQPACK	N	1	70.00	1 *S
M68TQP052SB1	L CSIC-52PINTQPACK	N	1	95.00	1 *S
M68TQP064SAMO1	L 64PIN TQPACK	N	1	95.00	1 *S
M68TQP064SA1	L 64PIN TQPACK	N	1	95.00	1 *S
M68TQP072SD1	L 72PINTQPACK	N	1	95.00	1 *S
M68TQP080SBMO1	L DEVICE ADAPTER FOR80QFP	N	1	95.00	1 *S
M68TQP080SB1	L DEVICE ADAPTER FOR80QFP	N	1	95.00	1 *S
M68TQP100RB1	L DEVICE ADAPTER FOR100QFP	N	1	150.00	1 *S
M68TQP100SDMO1	L DEVICE ADAPTER FOR100QFP	N	1	150.00	1 *S
M68TQP100SD1	L DEVICE ADAPTER FOR100QFP	N	1	150.00	1 *S
M68TQP120SDMO1	J DEVICE ADAPTER FOR120QFP	N	1	150.00	1 *S
M68TQP120SD1	J DEVICE ADAPTER FOR120QFP	N	1	150.00	1 *S
M68TQP132SC1	L AMCU-132PIN PPACK ICE	N	1	150.00	1 *S
M68TQP144SDMO1	J DEVICE ADAPTER FOR144QFP	N	1	150.00	1 *S
M68TQP144SD1	J DEVICE ADAPTER FOR144QFP	N	1	150.00	1 *S
M68TQP160SBMO1	J DEVICE ADAPTER FOR160QFP	N	1	150.00	1 *S
M68TQP160SB1	J DEVICE ADAPTER FOR160QFP	N	1	150.00	1 *S
M68TQS032SAG1	L CSIC-32PINTQSOCKET	N	1	65.00	1 *S
M68TQS032SAN1	L CSIC-32PINTQSOCKET	N	1	65.00	1 *S
M68TQS044SAF1	L CSIC MCU44PIN TQSOCKET	N	1	50.00	1 *S
M68TQS044SAG1	L CSIC MCU44PIN TQSOCKET	N	1	50.00	1 *S
M68TQS052SBF1	L CSIC-52PINTQSOCKET	N	1	65.00	1 *S
M68TQS052SBG1	L CSIC-52PINTQSOCKET	N	1	65.00	1 *S

Type No.	Grp/Description	Per PC	Unit Qty	Sugg. Resale Price	Factory Order Incrmnt
M68TQS064SAF1	L 64PINTQSOCKET	N	1	65.00	1 *S
M68TQS064SAG1	L 64PINTQSOCKET	N	1	65.00	1 *S
M68TQS072SDF1	L 72PINTQSOCKET	N	1	65.00	1 *S
M68TQS072SDG1	L 72PINTQSOCKET	N	1	65.00	1 *S
M68TQS080SBG1	L AMCU-80-PINTQSOCKET	N	1	65.00	1 *S
M68TQS080SBN1	L DEVICE ADAPTER FOR80QFP	N	1	65.00	1 *S
M68TQS080SBW1	L DEVICE ADAPTER FOR80QFP	N	1	65.00	1 *S
M68TQS100SDF1	L DEVICE ADAPTER FOR100QFP	N	1	95.00	1 *S
M68TQS100SDG1	L AMCU-100PINTQSOCKET	N	1	95.00	1 *S
M68TQS100SDN1	L DEVICE ADAPTER FOR100QFP	N	1	95.00	1 *S
M68TQS100SDW1	L DEVICE ADAPTER FOR100QFP	N	1	95.00	1 *S
M68TQS120SDF1	J DEVICE ADAPTER FOR120QFP	N	1	75.00	1 *S
M68TQS120SDG1	J DEVICE ADAPTER FOR120QFP	N	1	75.00	1 *S
M68TQS120SDN1	J DEVICE ADAPTER FOR120QFP	N	1	75.00	1 *S
M68TQS120SDW1	J DEVICE ADAPTER FOR120QFP	N	1	75.00	1 *S
M68TQS132SCF1	J DEVICE ADAPTER FOR132QFP	N	1	120.00	1 *S
M68TQS132SCG1	J DEVICE ADAPTER FOR132QFP	N	1	120.00	1 *S
M68TQS132SCN1	J DEVICE ADAPTER FOR132QFP	N	1	120.00	1 *S
M68TQS132SCW1	J DEVICE ADAPTER FOR132QFP	N	1	120.00	1 *S
M68TQS144SDF1	L AMCU	N	1	120.00	1 *S
M68TQS144SDG1	L AMCU	N	1	120.00	1 *S
M68TQS144SDN1	J DEVICE ADAPTER FOR144QFP	N	1	75.00	1 *S
M68TQS144SDW1	J DEVICE ADAPTER FOR144QFP	N	1	75.00	1 *S
M68TQS160SBF1	J DEVICE ADAPTER FOR160QFP	N	1	85.00	1 *S
M68TQS160SBG1	J DEVICE ADAPTER FOR160QFP	N	1	85.00	1 *S
M68TQS160SBN1	J DEVICE ADAPTER FOR160QFP	N	1	85.00	1 *S
M68TQS160SBW1	J DEVICE ADAPTER FOR160QFP	N	1	85.00	1 *S
M683FSRTEKHDX20	J RTEK2.0 KERNEL	N	1	5000.00	1 *S
M68300PFB	J 68300 PLATFORM BOARD	N	1	300.00	1 *S
M68302ADI-PC	N BOARD & CABLE FOR IBM PC	N	1	350.00	1 S
M68302FADS	N 68302 FLEXIBLE APPLICATIO	N	1	995.00	1 S
M68302FADS-ENA	N ADAPTER BOARD M68302FADS	N	1	200.00	1 S
M68302FADS-LC	N M68302FADS INCLUDING 68LC	N	1	995.00	1 S
M68302FADS-PM	N M68302FADS INCLUDING 68PM	N	1	995.00	1 S
M68306AN	L EVALUATION BOARD 68306	N	1	349.00	1
M68307EVM	L EVALUATION BOARD	N	1	348.75	1 S
M68328ADS	V 328 APPS DEV. SYSTEM	N	1	1887.50	1
M68340EST	L DEVELOPMENT BOARD 340	N	1	500.00	1
M68341EST	L DEVELOPMENT BOARD 341	N	1	500.00	1
M68349IDP	L EVALUATION BOARD 68349	N	1	600.00	1 S
M68360ADI-PC	N I/F KIT FOR IBM PC	N	1	350.00	1 S
M68360QUADS	N QUICC APP DEV SYS	N	1	1995.00	1 S
NE555N	B LINTIMING CIRCUIT	2	50	.45	1000 †
NE556N	B LINDUAL TIMING CIRCUIT	2	25	.41	500 †
PBF259RSRL1	A SILICON PLASTIC TRANS	2	2000	.17	2000 †

A = OSPD/Power
 B = Analog/Logic
 J = Transportation
 L = Consumer
 N = Networking
 V = Wireless

S = Proprietary Device
 B = Motorola Blue Chip Program Device
 P = Phoenix Program
 * = First Time in Book
 † \$200 Minimum Waived

N = Key New Motorola Device
 R = Key "Focus" Motorola Device

1 = Mature, Stable, High-Volume Device
 2 = Moderate-Volume Device
 3 = Low-Volume Device

COMMERCIAL COMPONENTS

Type No.	Grp/Description	Per Unit PC	Unit Qty	Sugg. Price	Factory Order Incrrmnt		Type No.	Grp/Description	Per Unit PC	Unit Qty	Sugg. Price	Factory Order Incrrmnt	
PBF259RSZL1	A SMALLSIGNAL	2	2000	.17	2000	†	P6KE160ARL	A REELPK/P6KE160A	2	4000	.44	4000	†
PC33291DW	J OCTALSERIAL SWITCH	N	30	8.73	30	S P	P6KE160CARL	A REELPACK/P6KE160CA	2	4000	.60	4000	†
PN2222	A SSGENPURNPNT092	2	5000	.09	5000	†	P6KE170A	A ZEN170V600W5%CASE17	3	1000	1.82	1000	†
PN2222A	A SSGENPURNPNT092	1	5000	.084	5000	†	P6KE170ARL	A REELPKFORP6KE170A	3	4000	1.00	4000	†
PN2222ARLRA	A SSNPNT092TAPE/REEL2K	2	2000	.084	2000	†	P6KE170CA	A HIGHPWRSURMTRNCLIPPER	N	1000	.60	1000	†
PN2222ARLRB	A REELPACKFORPN2222A	2	2000	.084	2000	†	P6KE170CARL	A REELPACK/P6KE170CA	2	4000	.60	4000	†
PN2222ARLRP	A SSG/PURNPNT092T/AMMO	N	2000	.084	2000	†	P6KE18A	A ZEN18V600W5%CASE17	2	1000	.36	1000	†
PN2907	A LASTORDERDATE:08/28/98	2	5000	.18	5000	†	P6KE18ARL	A REELPK/P6KE18A	2	4000	.36	4000	†
PN2907A	A SSGENPURNPNT092	1	5000	.084	5000	†	P6KE18CA	A ZEN18V5%CLIPPER	2	1000	.60	1000	†
PZTA14T1	A SSDARLINGTONNPN SOT-223	N	1000	.46	1000	†	P6KE180ARL	A REELPKFORP6KE180A	2	4000	.44	4000	†
PZTA42T1	A SSHIGH-VOLTNPN SOT-223	2	1000	.50	1000	†	P6KE180CARL	A REELPK/P6KE180CA	2	4000	.60	4000	†
PZTA64T1	A SSDARLINGTONPNP SOT-223	2	1000	.46	1000	†	P6KE20A	A ZEN20V600W5%CASE17	3	1000	1.00	1000	†
PZTA92T1	A SSHIGH-VOLTPNP SOT-223	2	1000	.50	1000	†	P6KE20ARL	A REELPK/P6KE20A	2	4000	.44	4000	†
PZTA96T1	A SSHIGH-VOLTPNP SOT-223	3	1000	1.15	1000	†	P6KE20CA	A ZEN20V5%CLIPPER	2	1000	.58	1000	†
PZT2222AT1	A SSAMP/SWITCHNPN SOT-223	1	1000	.38	1000	†	P6KE200A	A ZEN200V600W5%CASE17	3	1000	1.00	1000	†
PZT2222AT3	A SSAMP/SWITCHNPN SOT-223	N	4000	.38	4000	†	P6KE200ARL	A REELPK/P6KE200A	2	4000	.44	4000	†
PZT2907AT1	A SSAMP/SWITCHPNP SOT-223	1	1000	.38	1000	†	P6KE200CA	A ZEN200V5%CLIPPER	3	1000	1.40	1000	†
PZT651T1	A HICURRNPN SOT223XSTR	N	1000	.46	1000	†	P6KE22A	A ZEN22V600W5%CASE17	3	1000	1.00	1000	†
PZT751T1	A PNP HICURRENT, SOT223	N	1000	.456	1000	†	P6KE22ARL	A REELPK/P6KE22A	2	4000	.44	4000	†
P6KE10A	A ZEN10V600W5%CASE17	N	1000	.44	1000	†	P6KE22CA	A ZEN20V5%CLIPPER	3	1000	1.16	1000	†
P6KE10ARL	A REELPACKFORP6KE10A	N	4000	.44	4000	†	P6KE24A	A ZEN24V600W5%CASE17	2	1000	.36	1000	†
P6KE10CA	A ZEN10V5%CLIPPER	3	1000	1.40	1000	†	P6KE24ARL	A REELPKFORP6KE24A	2	4000	.36	4000	†
P6KE100A	A ZEN100V600W5%CASE17	3	1000	1.00	1000	†	P6KE24CA	A ZEN24V5%CLIPPER	3	1000	1.28	1000	†
P6KE100ARL	A REELPK/P6KE100A	2	4000	.44	4000	†	P6KE24CARL	A REELPACK/P6KE24CA	3	4000	1.74	4000	†
P6KE100AARL	A REELPK/P6KE100A	2	4000	.44	4000	†	P6KE27A	A ZEN27V600W5%CASE17	3	1000	.82	1000	†
P6KE11ARL	A REELPK/P6KE11A	2	4000	.36	4000	†	P6KE27ARL	A REELPK/P6KE27A	2	4000	.36	4000	†
P6KE11CA	A ZEN11V5%CLIPPER	3	1000	1.16	1000	†	P6KE27CA	A ZEN27V5%CLIPPER	2	1000	.58	1000	†
P6KE110A	A ZEN110V600W5%CASE17	3	1000	1.00	1000	†	P6KE30A	A ZEN30V600W5%CASE17	2	1000	.36	1000	†
P6KE110ARL	A ZEN110V600W10%T/R	3	4000	1.00	4000	†	P6KE30ARL	A REELPK/P6KE30A	2	4000	.36	4000	†
P6KE110CA	A ZENERDIODE, CLIPPER	N	1000	.78	1000	†	P6KE30CA	A ZEN30V5%CLIPPER	3	1000	1.16	1000	†
P6KE110CARL	A REELPACK/P6KE110CA	2	4000	.60	4000	†	P6KE33A	A ZEN33V600W5%CASE17	1	1000	.36	1000	†
P6KE12A	A ZEN12V600W5%CASE17	N	1000	.36	1000	†	P6KE33ARL	A REELPK/P6KE33A	2	4000	.36	4000	†
P6KE12ARL	A REELPK/P6KE12A	2	4000	.36	4000	†	P6KE33CA	A ZEN33V5%CLIPPER	2	1000	.89	1000	†
P6KE12CA	A ZEN12V5%CLIPPER	3	1000	1.40	1000	†	P6KE36A	A ZEN36V600W5%CASE17	2	1000	.36	1000	†
P6KE120A	A ZEN120V600W5%CASE17	3	1000	1.00	1000	†	P6KE36ARL	A REELPK/P6KE36A	2	4000	.36	4000	†
P6KE13ARL	A REELPK/P6KE13A	2	4000	.36	4000	†	P6KE39A	A ZEN39V600W5%CASE17	2	1000	.44	1000	†
P6KE13CA	A ZEN13V5%CLIPPER	2	1000	.60	1000	†	P6KE39ARL	A REELPK/P6KE39A	2	4000	.44	4000	†
P6KE130A	A ZEN130V600W5%CASE17	3	1000	1.00	1000	†	P6KE43ARL	A REELPK/P6KE43A	2	4000	.44	4000	†
P6KE130ARL	A ZENERDIODE	3	4000	1.00	4000	†	P6KE47A	A ZEN47V600W5%CASE17	3	1000	1.00	1000	†
P6KE130CA	A ZENERDIODE, CLIPPER	2	1000	.79	1000	†	P6KE47ARL	A REELPKFORP6KE47A	2	4000	.44	4000	†
P6KE15A	A ZEN15V600W5%CASE17	1	1000	.36	1000	†	P6KE47CA	A ZEN47V5%CLIPPER	2	1000	.60	1000	†
P6KE15ARL	A REELPK/P6KE15A	2	4000	.36	4000	†	P6KE51A	A ZEN51V600W5%CASE17	3	1000	.82	1000	†
P6KE15CA	A ZEN15V5%CLIPPER	2	1000	.60	1000	†	P6KE51ARL	A REELPACKFORP6KE51A	2	4000	.36	4000	†
P6KE150A	A ZEN150V600W5%CASE17	3	1000	1.00	1000	†	P6KE51CA	A ZEN51V5%CLIPPER	3	1000	1.40	1000	†
P6KE16A	A ZEN16V600W5%CASE17	3	1000	.82	1000	†	P6KE56A	A ZEN56V600W5%CASE17	3	1000	.89	1000	†
P6KE16ARL	A REELPK/P6KE16A	2	4000	.36	4000	†							

A = OSPD/Power
 B = Analog/Logic
 J = Transportation
 L = Consumer
 N = Networking
 V = Wireless

S = Proprietary Device
 B = Motorola Blue Chip Program Device
 P = Phoenix Program
 ★ = First Time in Book
 † \$200 Minimum Waived

N = Key New Motorola Device
 R = Key "Focus" Motorola Device

1 = Mature, Stable, High-Volume Device
 2 = Moderate-Volume Device
 3 = Low-Volume Device

EFFECTIVE DATE: JANUARY 10, 1998

COMMERCIAL COMPONENTS

Type No.	Grp/Description	Per Unit Sugg.		Factory Order	
		Resale Price	Price Incrmt		
P6KE56ARL	A REELPK/P6KE56A	2 4000	.39	4000	†
P6KE56CA	A ZEN56V5%CLIPPER	3 1000	1.20	1000	†
P6KE56CARL	A REELPACK/P6KE56CA	3 4000	1.20	4000	†
P6KE6.8A	A ZEN6.8V600W5%CASE17	1 1000	.36	1000	†
P6KE6.8ARL	A REELPK/P6KE6.8A	2 4000	.36	4000	†
P6KE6.8CA	A ZEN6.8V5%CLIPPER	2 1000	.60	1000	†
P6KE62A	A ZEN62V600W5%CASE17	3 1000	.82	1000	†
P6KE62ARL	A REELPK/P6KE62A	2 4000	.36	4000	†
P6KE62CA	A ZEN62V5%CLIPPER	2 1000	.60	1000	†
P6KE68A	A ZEN68V600W5%CASE17	3 1000	1.00	1000	†
P6KE68ARL	A REEL PACK FOR P6KE68A	2 4000	.44	4000	†
P6KE68CA	A ZEN68V5%CLIPPER	2 1000	.60	1000	†
P6KE7.5A	A ZEN7.5V600W5%CASE17	2 1000	.44	1000	†
P6KE7.5ARL	A REELPK/P6KE7.5A	2 4000	.44	4000	†
P6KE7.5CA	A ZEN7.5V5%CLIPPER	2 1000	.58	1000	†
P6KE7.5CARL	A REELPK/P6KE7.5CA	2 4000	.58	4000	†
P6KE75A	A ZEN75V600W5%CASE17	3 1000	1.00	1000	†
P6KE75CA	A ZEN75V5%CLIPPER	3 1000	1.20	1000	†
P6KE75CARL	A REELPK/P6KE75CA	3 4000	1.20	4000	†
P6KE8.2A	A ZEN8.2V600W5%CASE17	3 1000	1.00	1000	†
P6KE8.2ARL	A ZEN8.2V600W5%CASE17	2 4000	.44	4000	†
P6KE8.2CA	A ZEN8.2V5%CLIPPER	3 1000	1.40	1000	†
P6KE82CA	A ZEN82V5%CLIPPER	3 1000	1.20	1000	†
P6KE82CARL	A REEL PACK/P6KE82CA	3 4000	1.20	4000	†
P6KE9.1A	A ZEN9.1V600W5%CASE17	3 1000	1.00	1000	†
P6KE9.1CA	A ZEN9.1V5%CLIPPER	3 1000	1.40	1000	†
P6KE9.1CARL	A REELPK/P6KE9.1CA	2 4000	.70	4000	†
P6KE91ARL	A REELPK/P6KE91A	2 4000	.44	4000	†
P6SMB10AT3	A H/PWR SUR MT TR SUP T/R	N 2500	.78	2500	†
P6SMB100AT3	A H/PWR SUR MT TR SUP T/R	N 2500	.78	2500	†
P6SMB11AT3	A H/PWR SUR MT TR SUP T/R	2 2500	.78	2500	†
P6SMB12AT3	A H/PWR SUR MT TR SUP T/R	2 2500	.78	2500	†
P6SMB13AT3	A H/PWR SUR MT TR SUP T/R	2 2500	.78	2500	†
P6SMB130AT3	A H/PWR SUR MT TR SUP T/R	2 2500	.78	2500	†
P6SMB15AT3	A H/PWR SUR MT TR SUP T/R	2 2500	.78	2500	†
P6SMB150AT3	A H/PWR SUR MT TR SUP T/R	N 2500	.78	2500	†
P6SMB16AT3	A H/PWR SUR MT TR SUP T/R	2 2500	.78	2500	†
P6SMB160AT3	A H/PWR SUR MT TR SUP T/R	N 2500	.78	2500	†
P6SMB170AT3	A H/PWR SUR MT TR SUP T/R	N 2500	.78	2500	†
P6SMB18AT3	A H/PWR SUR MT TR SUP T/R	2 2500	.78	2500	†
P6SMB180AT3	A H/PWR SUR MT TR SUP T/R	N 2500	.78	2500	†
P6SMB200AT3	A H/PWR SUR MT TR SUP T/R	N 2500	.78	2500	†
P6SMB22AT3	A H/PWR SUR MT TR SUP T/R	N 2500	.78	2500	†
P6SMB24AT3	A H/PWR SUR MT TR SUP T/R	2 2500	.78	2500	†
P6SMB27AT3	A H/PWR SUR MT TR SUP T/R	2 2500	.78	2500	†

Type No.	Grp/Description	Per Unit Sugg.		Factory Order	
		Resale Price	Price Incrmt		
P6SMB33AT3	A H/PWR SUR MT TR SUP T/R	2 2500	.78	2500	†
P6SMB36AT3	A H/PWR SUR MT TR SUP T/R	2 2500	.78	2500	†
P6SMB39AT3	A H/PWR SUR MT TR SUP T/R	N 2500	.78	2500	†
P6SMB43AT3	A H/PWR SUR MT TR SUP T/R	2 2500	.78	2500	†
P6SMB51AT3	A H/PWR SUR MT TR SUP T/R	2 2500	.78	2500	†
P6SMB56AT3	A H/PWR SUR MT TR SUP T/R	2 2500	.78	2500	†
P6SMB6.8AT3	A H/PWR SUR MT TR SUP T/R	2 2500	.78	2500	†
P6SMB62AT3	A H/PWR SUR MT TR SUP T/R	2 2500	.78	2500	†
P6SMB68AT3	A H/PWR SUR MT TR SUP T/R	N 2500	.78	2500	†
P6SMB7.5AT3	A H/PWR SUR MT TR SUP T/R	N 2500	.78	2500	†
P6SMB75AT3	A H/PWR SUR MT TR SUP T/R	2 2500	1.14	2500	†
P6SMB8.2AT3	A H/PWR SUR MT TR SUP T/R	N 2500	.78	2500	†
P6SMB82AT3	A H/PWR SUR MT TR SUP T/R	N 2500	.78	2500	†
P6SMB9.1AT3	A H/PWR SUR MT TR SUP T/R	N 2500	.78	2500	†
SAA1042V	B STEPPER MOTOR DRIVER	1 25	9.50	25	S P †
SA10A	A ZEN10V500WC59-04	3 1000	1.03	1000	†
SA10CA	A ZEN6.4V500WCLIPPER	3 1000	1.40	1000	†
SA100A	A ZEN11V500WC59-04	3 1000	1.68	1000	†
SA100CA	A ZEN11V500WCLIPPER	3 1000	1.50	1000	†
SA100CARL	A ZEN11V500WCLIPPER	3 5000	1.36	5000	†
SA11A	A ZEN11V500WCC59-04	3 1000	1.00	1000	†
SA11CA	A ZEN11V500WCLIPPER	3 1000	1.40	1000	†
SA11CARL	A ZENER DIODE	3 5000	1.40	5000	†
SA110A	A ZEN110V500WC59-04	3 1000	1.00	1000	†
SA110CA	A ZEN110V500WCLIPPER	3 1000	1.50	1000	†
SA12A	A ZEN12V500WC59-02	2 1000	.32	1000	†
SA12ARL	A REEL PACK FOR SA12A	2 5000	.44	5000	†
SA12CA	A ZEN12V500WCLIPPER	2 1000	.56	1000	†
SA120A	A ZEN120V500WC59-02	3 1000	1.00	1000	†
SA120ARL	A ZEN133V500WC59-02	3 5000	.73	5000	†
SA13A	A ZEN13V500WC59-02	2 1000	.32	1000	†
SA13ARL	A ZENER DIODE	2 5000	.44	5000	†
SA13CA	A ZEN13V500WCLIPPER	2 1000	.56	1000	†
SA13CARL	A ZEN13V500WCLIPPER	2 5000	.56	5000	†
SA130ARL	A REEL PACK FOR SA130A	2 5000	.32	5000	†
SA14A	A ZEN14V500WC59-02	3 1000	1.00	1000	†
SA14CA	A ZEN15.6V500WCLIPPER	3 1000	1.58	1000	†
SA15A	A ZEN15V500WC59-02	2 1000	.32	1000	†
SA15ARL	A REEL PACK FOR SA15A	2 5000	.44	5000	†
SA15CA	A ZEN15V500WCLIPPER	2 1000	.56	1000	†
SA150A	A ZEN150V500WC59-02	3 1000	1.08	1000	†
SA150CA	A ZEN150V500WCLIPPER	3 1000	1.62	1000	†
SA16A	A ZEN16V500WC59-02	3 1000	1.00	1000	†
SA16CA	A ZEN16V500WCLIPPER	3 1000	1.74	1000	†
SA160A	A ZEN160V500WC59-02	2 1000	.32	1000	†

A = OSPD/Power
 B = Analog/Logic
 J = Transportation
 L = Consumer
 N = Networking
 V = Wireless

S = Proprietary Device
 B = Motorola Blue Chip Program Device
 P = Phoenix Program
 ★ = First Time in Book
 † \$200 Minimum Waived

N = Key New Motorola Device
 R = Key "Focus" Motorola Device

1 = Mature, Stable, High-Volume Device
 2 = Moderate-Volume Device
 3 = Low-Volume Device

EFFECTIVE DATE: JANUARY 10, 1998

COMMERCIAL COMPONENTS

Type No.	Grp/Description	Per Unit Sugg. Factory				Type No.	Grp/Description	Per Unit Sugg. Factory					
		PC	Qty	Price				Order	PC	Qty		Price	Order
SA160ARL	A ZENER DIODE T/R	2	5000	.32	5000	†	SA6.5A	A ZEN6.5V500WC59-02	3	1000	1.00	1000	†
SA170ARL	A REEL PACK FOR SA170A	2	5000	.32	5000	†	SA6.5CA	A ZEN6.5V500WCLIPPER	3	1000	1.16	1000	†
SA18A	A ZEN20V500WC59-02	3	1000	1.21	1000	†	SA60ARL	A REEL PACK FOR SA60A	2	5000	.32	5000	†
SA18ARL	A ZENERSUPPRESSORST/R	3	5000	1.14	5000	†	SA60CARL	A ZEN66.7V500WCLIPPER	3	5000	1.40	5000	†
SA18CA	A ZEN18V500WCLIPPER	3	1000	1.16	1000	†	SA64A	A ZEN71.1V500WC59-02	3	1000	1.00	1000	†
SA20A	A ZEN20V500WC59-02	2	1000	.32	1000	†	SA64CA	A ZEN64V500WCLIPPER	3	1000	1.12	1000	†
SA20CA	A ZEN20V500WCLIPPER	2	1000	.56	1000	†	SA7.0A	A ZEN7.78V500WC59-02	3	1000	1.00	1000	†
SA22A	A ZEN22V500WC59-02	3	1000	.73	1000	†	SA7.0CA	A ZEN7V500WCLIPPER	3	1000	1.16	1000	†
SA24A	A ZEN24V500WC59-02	3	1000	.82	1000	†	SA7.5A	A ZEN7.5V500WC59-02	3	1000	.73	1000	†
SA24CA	A ZEN24V500WCLIPPER	3	1000	1.16	1000	†	SA7.5ARL	A ZENER DIODE T/R	3	5000	.73	5000	†
SA26A	A ZEN26V500WC59-02	3	1000	1.00	1000	†	SA7.5CA	A ZEN8.33V500WCLIPPER	3	1000	1.40	1000	†
SA26CARL	A ZENER DIODE T/R	3	5000	1.74	5000	†	SA70A	A ZEN70V500WC59-02	3	1000	.73	1000	†
SA28A	A ZEN31.1V500WC59-02	3	1000	1.00	1000	†	SA70ARL	A ZEN70V500WC59-02	3	5000	.73	5000	†
SA28ARL	A REEL PACK FOR SA28A	2	5000	.32	5000	†	SA70CA	A ZEN70V500WCLIPPER	3	1000	1.12	1000	†
SA28CA	A ZEN28V500WCLIPPER	3	1000	1.12	1000	†	SA78A	A ZEN78V500WC59-02	3	1000	.73	1000	†
SA30A	A ZEN30V500WC59-02	N	1000	.32	1000	†	SA78CA	A ZEN78V500WCLIPPER	3	1000	1.12	1000	†
SA30ARL	A ZEN33.3V500WC59-02 T/R	2	5000	.44	5000	†	SA8.0A	A ZEN8V500WC59-02	2	1000	.32	1000	†
SA30CA	A ZEN30V500WCLIPPER	3	1000	1.12	1000	†	SA8.5A	A ZEN8.5V500WC59-02	3	1000	.73	1000	†
SA33A	A ZEN33V500WC59-02	3	1000	1.00	1000	†	SA8.5CARL	A ZEN9.44V500WCLIPPER	3	5000	1.40	5000	†
SA33ARL	A REEL PACK FOR SA33A	3	5000	1.00	5000	†	SA85CA	A ZEN85V500WCLIPPER	3	1000	1.12	1000	†
SA33CA	A ZEN33V500WCLIPPER	3	1000	1.58	1000	†	SA9.0A	A ZEN9V500WC59-02	3	1000	.73	1000	†
SA33CARL	A ZEN36.7V500WCLIPPER	3	5000	1.40	5000	†	SA9.0ARL	A ZENER DIODE T/R	3	5000	.73	5000	†
SA36A	A ZEN40V500WC59-02	3	1000	1.00	1000	†	SA9.0CA	A ZEN10V500WCLIPPER	3	1000	1.40	1000	†
SA36ARL	A ZEN40V500WC59-02	2	5000	.32	5000	†	SA9.0CARL	A ZENER DIODE	3	5000	1.40	5000	†
SA36CA	A ZEN36V500WCLIPPER	2	1000	.56	1000	†	SC141D	A TRIAC6A400V T0220	1	500	.84	500	†
SA40A	A ZEN40V500WC59-02	3	1000	1.11	1000	†	SC146D	A TRIAC10A400V T0220	2	500	.92	500	†
SA40ARL	A ZENER DIODE T/R	3	5000	1.26	5000	†	SG3525AN	B LIN PWM CONTROL CIRCUIT	1	25	2.02	25	†
SA43A	A ZEN47.8V500WC59-02	3	1000	1.00	1000	†	SG3526N	B LIN PWM CONTROL CIRCUIT	1	20	2.62	20	†
SA43CA	A ZEN43V500WCLIPPER	3	1000	1.12	1000	†	SN54LS00J	B LS QD2-INPUT NAND GATE	2	25	1.19	500	†
SA45A	A ZEN50V500WC59-02	3	1000	1.00	1000	†	SN54LS02J	B LS QD2-INPUT NOR GATE	2	25	1.19	500	†
SA45ARL	A ZEN50V500WC59-02	3	5000	.74	5000	†	SN54LS04J	B LS HEX INVERTER	2	25	1.19	500	†
SA45CA	A ZEN45V500WCLIPPER	3	1000	1.12	1000	†	SN54LS08J	B LS QD2 INPUT AND GATE	2	25	1.19	500	†
SA45CARL	A ZEN50V500WCLIPPER	3	5000	1.40	5000	†	SN54LS109AJ	B LSDL JK POS EDG-TRIG FF	3	25	2.48	500	†
SA48A	A ZEN48V500WC59-02	3	1000	1.13	1000	†	SN54LS112AJ	B LSDL JK NEG EDG-TRIG FF	3	25	2.55	500	†
SA48ARL	A ZEN53.3V500WC59-02	3	5000	.73	5000	†	SN54LS122J	B LS RETRIG MONOSTBL MLTVBR	3	25	2.86	500	†
SA48CA	A ZEN48V500WCLIPPER	3	1000	1.12	1000	†	SN54LS123J	B LS RETRIG MONOST MLTVBR	2	25	1.40	500	†
SA48CARL	A ZEN53.3V500WCLIPPER	3	5000	1.36	5000	†	SN54LS132J	B LS QD2 I/P SCH TRIG NAND	3	25	2.90	500	†
SA5.0A	A ZEN5.0V500WC59-02	1	1000	.32	1000	†	SN54LS138J	B LSDL1-OF-8-DECODR/DEMUX	2	25	1.28	500	†
SA5.0ARL	A REEL PACK FOR SA5.0A	2	5000	.44	5000	†	SN54LS139J	B LSDL1-OF-4-DECODR/DEMUX	3	25	2.55	500	†
SA54A	A ZEN54V500WC59-02	3	1000	1.07	1000	†	SN54LS14J	B LS SCH TRIG DLGT/HEX INV	2	25	1.28	500	†
SA54CA	A ZEN54V500WCLIPPER	3	1000	1.12	1000	†	SN54LS155J	B LAST ORDER DATE:03/27/98	3	25	2.38	500	†
SA6.0A	A ZEN6V500WC59-02	2	1000	.32	1000	†	SN54LS161AJ	B LS BCD DEC/4BIT BIN CNTRS	3	25	2.76	500	†
SA6.0ARL	A ZEN6.67V500WC59-02 T/R	2	5000	.44	5000	†	SN54LS164J	B LS SERIAL IN PARA OUT SR	2	25	1.44	500	†
SA6.0CA	A ZEN6V500WCLIPPER	3	1000	1.40	1000	†	SN54LS175J	B LS QDD FLIP FLOP W/CLEAR	2	25	1.33	500	†
SA6.0CARL	A ZEN6.67V500WCLIPPER	3	5000	1.36	5000	†	SN54LS196J	B LS4STG PRESETBL RIP CNTR	3	25	3.45	500	†

A = OSPD/Power
 B = Analog/Logic
 J = Transportation
 L = Consumer
 N = Networking
 V = Wireless

S = Proprietary Device
 B = Motorola Blue Chip Program Device
 P = Phoenix Program
 * = First Time in Book
 † \$200 Minimum Waived

N = Key New Motorola Device
 R = Key "Focus" Motorola Device

1 = Mature, Stable, High-Volume Device
 2 = Moderate-Volume Device
 3 = Low-Volume Device

EFFECTIVE DATE: JANUARY 10, 1998

COMMERCIAL COMPONENTS

Type No.	Grp/Description	Per Unit Sugg. Factory			Order	Incrmnt
		PC	Qty	Price		
SN54LS221J	B LS DL MONOSTBL MLTVBRTR	2	25	1.89	500	†
SN54LS244J	B LS OCTAL BUFF/LINE DRVR	2	19	2.20	380	†
SN54LS245J	B LS OCTAL BUS TRANSCEIVER	2	19	2.29	380	†
SN54LS273J	B LS8-BIT REG W/CLEAR	2	19	2.23	380	†
SN54LS283J	B LS4-BIT BIN FULLADDER	3	25	3.07	500	†
SN54LS32J	B LS QD2/1P OR GATE	2	25	1.37	500	†
SN54LS373J	B LS OCTAL TRANSPARNT LATCH	2	19	2.20	380	†
SN54LS374J	B LS OCTAL DFF3-STATE	2	19	2.21	380	†
SN54LS393J	B LS DL4-STAGE BIN CNTR	2	25	1.91	500	†
SN54LS399J	B LS QD2-PORT REG	3	25	3.45	500	†
SN54LS640J	B LS OCTAL BUS TRANSCEIVERS	3	19	5.73	380	†
SN54LS670J	B LS4X4 REG FILE W/3ST O/P	3	25	3.91	500	†
SN54LS74AJ	B LS DL D TYPE POSEGE FF	2	25	1.24	500	†
SN54LS86J	B LS QD2/1P EXCOR	3	25	2.31	500	†
SN74LS00D	B LS QD2/1P NAND GATE	2	55	.19	55	†
SN74LS00DR2	B LS QD2/1P NAND GATE	2	2500	.19	2500	†
SN74LS00N	B LS QD2/1P NAND GATE	1	25	.19	500	†
SN74LS01D	B LS QD2/1P NAND GATE O/C	N	55	.19	55	†
SN74LS01N	B LS QD2/1P NAND GATE O/C	2	25	.19	500	†
SN74LS02D	B LS QD2/1P NOR GATE	2	55	.19	55	†
SN74LS02DR2	B LS QD2/1P NOR GATE	2	2500	.19	2500	†
SN74LS02N	B LS QD2/1P NOR GATE	1	25	.19	500	†
SN74LS03D	B LS QD2/1P NAND GATE O/C	N	55	.19	55	†
SN74LS03DR2	B LS QD2/1P NAND GATE O/C	2	2500	.19	2500	†
SN74LS03N	B LS QD2/1P NAND GATE O/C	1	25	.19	500	†
SN74LS04D	B LS HEX INVERTER	2	55	.19	55	†
SN74LS04DR2	B LS HEX INVERTER	N	2500	.19	2500	†
SN74LS04N	B LS HEX INVERTER	1	25	.19	500	†
SN74LS05D	B LS HEX INVERTER O/C	2	55	.19	55	†
SN74LS05DR2	B LS HEX INVERTER O/C	2	2500	.19	2500	†
SN74LS05N	B LS HEX INVERTER O/C	1	25	.19	500	†
SN74LS08D	B LS QD2/1P AND GATE	2	55	.19	55	†
SN74LS08DR2	B LS QD2/1P AND GATE	2	2500	.19	2500	†
SN74LS08N	B LS QD2/1P AND GATE	1	25	.19	500	†
SN74LS09D	B LS QD2/1P AND GATE O/C	2	55	.19	55	†
SN74LS09N	B LS QD2/1P AND GATE O/C	1	25	.19	500	†
SN74LS10D	B LS TRPL3/1P NAND GATE	2	55	.19	55	†
SN74LS10DR2	B LS TRPL3/1P NAND GATE	2	2500	.19	2500	†
SN74LS10N	B LS TRPL3/1P NAND GATE	1	25	.19	500	†
SN74LS107AD	B LS DL JK FLIP FLOP	3	55	.91	55	†
SN74LS107AN	B LS DL JK FLIP FLOP	2	25	.32	500	†
SN74LS109AN	B LS DL JK POS EDG-TRIG FF	2	25	.32	500	†
SN74LS11D	B LS TRIPLE3/1P AND GATE	N	55	.19	55	†
SN74LS11N	B LS TRIPLE3/1P AND GATE	1	25	.19	500	†
SN74LS112AN	B LS TRPL3/1P NAND GATE O/C	2	25	.32	500	†

Type No.	Grp/Description	Per Unit Sugg. Factory			Order	Incrmnt
		PC	Qty	Price		
SN74LS122N	B LS RETRIG MONOSTBL MLTVBR	1	25	.45	500	†
SN74LS123D	B LS RETRIG MONOSTBL MLTVBR	2	48	.49	48	†
SN74LS123DR2	B LS RETRIG MONOSTBL MLTVBR	2	2500	.50	2500	†
SN74LS123J	B LS RETRIG MONOSTBL MLTVBR	3	25	2.59	500	†
SN74LS123N	B LS RETRIG MONOSTBL MLTVBR	1	25	.45	500	†
SN74LS125AD	B LS QD3-STATE BUFFERS	2	55	.38	55	†
SN74LS125ADR2	B LS QD3-STATE BUFFERS	2	2500	.40	2500	†
SN74LS125AN	B LS QD3-STATE BUFFERS	1	25	.36	500	†
SN74LS126AD	B LS QD3-STATE BUFFERS	2	55	.36	55	†
SN74LS126ADR2	B LS QD3-STATE BUFFERS	2	2500	.38	2500	†
SN74LS126AN	B LS QD3-STATE BUFFERS	1	25	.34	500	†
SN74LS132D	B LS QD2/1P SCH TRIG NAND	2	55	.54	55	†
SN74LS132DR2	B LS QD2/1P SCH TRIG NAND	2	2500	.56	2500	†
SN74LS132N	B LS QD2/1P SCH TRIG NAND	1	25	.50	500	†
SN74LS136N	B LS QD2/1P EXCOR O/C	2	25	.40	500	†
SN74LS137N	B LS3-8 LINE DEC/DEMUX	2	25	.38	500	†
SN74LS138D	B LS1-OF-8 DECDR/DEMUX	2	48	.38	48	†
SN74LS138DR2	B LS1-OF-8 DECDR/DEMUX	2	2500	.40	2500	†
SN74LS138N	B LS1-OF-8 DECDR/DEMUX	1	25	.34	500	†
SN74LS139DR2	B LS DL1-OF-4 DECDR/DEMUX	2	2500	.47	2500	†
SN74LS139N	B LS DL1-OF-4 DECDR/DEMUX	1	25	.41	500	†
SN74LS14D	B LS SCH TRIG DLGT/HEX INV	1	55	.31	55	†
SN74LS14DR2	B LS SCH TRIG DLGT/HEX INV	2	2500	.31	2500	†
SN74LS14N	B LS SCH TRIG DLGT/HEX INV	1	25	.27	500	†
SN74LS145DR2	B LS1-OF-10 DEC/DRVRO/C	2	2500	.56	2500	†
SN74LS145N	B LS1-OF-10 DEC/DRVRO/C	1	25	.49	500	†
SN74LS147N	B LS10-4 AND8-3 ENCODER	2	25	1.10	500	S †
SN74LS148D	B LS10-4 AND8-3 ENCODER	2	48	.86	48	†
SN74LS148DR2	B LS10-4 AND8-3 ENCODER	2	2500	.90	2500	†
SN74LS148N	B LS10-4 AND8-3 ENCODER	1	25	.86	500	†
SN74LS151N	B LS8 INPUT MULTIPLEXER	2	25	.34	500	†
SN74LS153N	B LS DL4 INPUT MULTIPLEXER	2	25	.34	500	†
SN74LS155N	B LS DL1/4 DEC/DEMUX	2	25	.34	500	†
SN74LS156D	B LS DL1/4 DEC/DEMUX	2	48	.38	48	†
SN74LS156DR2	B LS DL1/4 DEC/DEMUX	2	2500	.40	2500	†
SN74LS156J	B LS DL1/4 DEC/DEMUX	3	25	2.42	500	†
SN74LS156N	B LS DL1/4 DEC/DEMUX	2	25	.34	500	†
SN74LS157D	B LS QD2 INPUT MULTIPLEXER	2	48	.38	48	†
SN74LS157DR2	B LS QD2 INPUT MULTIPLEXER	2	2500	.40	2500	†
SN74LS157N	B LS QD2 INPUT MULTIPLEXER	1	25	.34	500	†
SN74LS158DR2	B LS QD2 INPUT MULTIPLEXER	2	2500	.40	2500	†
SN74LS158N	B LS QD2 INPUT MULTIPLEXER	2	25	.34	500	†
SN74LS161ADR2	B LS BCD DEC/4 BIT BIN CTRS	2	2500	.45	2500	†
SN74LS161AN	B LS BCD DEC/4 BIT BIN CTRS	1	25	.38	500	†
SN74LS163AN	B LS BCD DEC/4 BIT BIN CTRS	1	25	.38	500	†

A = OSPD/Power
 B = Analog/Logic
 J = Transportation
 L = Consumer
 N = Networking
 V = Wireless

S = Proprietary Device
 B = Motorola Blue Chip Program Device
 P = Phoenix Program
 * = First Time in Book
 † \$200 Minimum Waived

N = Key New Motorola Device
 R = Key "Focus" Motorola Device

1 = Mature, Stable, High-Volume Device
 2 = Moderate-Volume Device
 3 = Low-Volume Device

EFFECTIVE DATE: JANUARY 10, 1998

COMMERCIAL COMPONENTS

Type No.	Grp/Description	Per Unit Sugg.		Factory Order	PC Qty	Price	Incrmnt	Type No.	Grp/Description	Per Unit Sugg.		Factory Order	PC Qty	Price	Incrmnt
		Resale	Price							Resale	Price				
SN74LS164D	B LS SERIAL-IN/PARA-OUT SR	2	55	.41	55	†	SN74LS245DW	B LS OCTAL BUS TRANSCEIVER	1	38	.32	38	†		
SN74LS164DR2	B LS SERIAL-IN/PARA-OUT SR	2	2500	.43	2500	†	SN74LS245DWR2	B LS OCTAL BUS TRANSCEIVER	1	1000	.32	1000	†		
SN74LS164N	B LS SERIAL-IN/PARA-OUT SR	1	25	.38	500	†	SN74LS245N	B LS OCTAL BUS TRANSCEIVER	1	18	.32	360	†		
SN74LS165D	B LS 8BIT PARA/SER CONVERTR	2	48	.76	48	†	SN74LS247D	B LS BCD TO7 SEG DEC/DRV R	2	48	.68	48	†		
SN74LS165DR2	B LS 8BIT PARA/SER CONVERTR	2	2500	.77	2500	†	SN74LS247J	B LS BCD TO7 SEG DEC/DRV R	3	25	3.45	500	†		
SN74LS165N	B LS 8BIT PARA/SER CONVERTR	1	25	.72	500	†	SN74LS247N	B LS BCD TO7 SEG DEC/DRV R	2	25	.68	500	†		
SN74LS166D	B LS 8-BIT SHIFT REGISTERS	2	48	.85	48	†	SN74LS251N	B LS 8I/P MUX W/3STATE O/P	1	25	.36	500	†		
SN74LS166J	B LS 8-BIT SHIFT REGISTERS	3	25	3.28	500	†	SN74LS253N	B LSDL4I/P MUX W/3ST O/P	2	25	.36	500	†		
SN74LS166N	B LS 8-BIT SHIFT REGISTERS	2	25	.81	500	†	SN74LS256N	B LSDL4-BIT ADDR LATCH	2	25	.95	500	S †		
SN74LS169N	B LS UP/DOWN BIN COUNTER	2	25	.90	500	†	SN74LS257BD	B LS QD21/P MUX W/3ST O/P	2	48	.40	48	†		
SN74LS174D	B LS HEX FF W/CLEAR	2	48	.41	48	†	SN74LS257BDR2	B LS QD21/P MUX W/3ST O/P	2	2500	.40	2500	†		
SN74LS174DR2	B LS HEX FF W/CLEAR	2	2500	.43	2500	†	SN74LS257BN	B LS QD21/P MUX W/3ST O/P	2	25	.36	500	†		
SN74LS174N	B LS HEX FF W/CLEAR	1	25	.34	500	†	SN74LS258BD	B LS QD21/P MUX W/3ST O/P	2	48	.40	48	†		
SN74LS175D	B LS QDD FLIP FLOP W/CLEAR	2	48	.41	48	†	SN74LS258BDR2	B LS QD21/P MUX W/3ST O/P	2	2500	.40	2500	†		
SN74LS175DR2	B LS QDD FLIP FLOP W/CLEAR	2	2500	.43	2500	†	SN74LS258BN	B LS QD21/P MUX W/3ST O/P	2	25	.36	500	†		
SN74LS175N	B LS QDD FLIP FLOP W/CLEAR	1	25	.34	500	†	SN74LS259D	B LS 8-BIT ADDR LATCH	2	48	.59	48	†		
SN74LS191DR2	B LS BIN UP/DN COUNTER	2	2500	.52	2500	†	SN74LS259DR2	B LS 8-BIT ADDR LATCH	2	2500	.61	2500	†		
SN74LS191J	B LS BIN UP/DN COUNTER	3	25	3.00	500	†	SN74LS259N	B LS 8-BIT ADDR LATCH	1	25	.56	500	†		
SN74LS191N	B LS BIN UP/DN COUNTER	1	25	.45	500	†	SN74LS26DR2	B LS QD2I/P NAND BUFFER	2	2500	.31	2500	†		
SN74LS192N	B LS BCD/DECADE UP/DN CNTR	2	25	.90	500	S †	SN74LS26N	B LS QD2I/P NAND BUFFER	2	25	.19	500	†		
SN74LS193N	B LS 4-BIT BIN UP/DN CNTR	1	25	.45	500	†	SN74LS260DR2	B LSDL5I/P NOR GATE	2	2500	.38	2500	†		
SN74LS195AD	B LS UNIV4-BIT SHFT REG	3	48	1.08	48	†	SN74LS260N	B LSDL5I/P NOR GATE	1	25	.32	500	†		
SN74LS195AJ	B LS UNIV4-BIT SHFT REG	3	25	3.00	500	†	SN74LS266N	B LS QD2I/PECX NORO/C	2	25	.34	500	†		
SN74LS195AN	B LS UNIV4-BIT SHFT REG	2	25	.45	500	†	SN74LS27N	B LS TRPL3I/P NOR GATE	1	25	.19	500	†		
SN74LS197N	B LS 4STG PRESETBL RP CNTR	2	25	.95	500	S †	SN74LS273DW	B LS 8-BIT REG W/CLEAR	2	38	.32	38	†		
SN74LS20D	B LSDL4I/P NAND GATE	3	55	.77	55	†	SN74LS273DWR2	B LS 8-BIT REG W/CLEAR	2	1000	.32	1000	†		
SN74LS20N	B LSDL4I/P NAND GATE	1	25	.19	500	†	SN74LS273N	B LS 8-BIT REG W/CLEAR	1	18	.32	360	†		
SN74LS21D	B LSDL4I/P AND GATE	N	55	.19	55	†	SN74LS279DR2	B LS QD SET-RESET LATCH	2	2500	.43	2500	†		
SN74LS21N	B LSDL4I/P AND GATE	1	25	.19	500	†	SN74LS279N	B LS QD SET-RESET LATCH	2	25	.36	500	†		
SN74LS221D	B LSDL MONOSTBL MLTVBRTR	2	48	.65	48	†	SN74LS280N	B LS 9-BIT O/E PARGEN/CHK	2	25	.58	500	†		
SN74LS221DR2	B LSDL MONOSTBL MLTVBRTR	2	2500	.68	2500	†	SN74LS283N	B LS 4-BIT BIN FULL ADDER	2	25	.50	500	†		
SN74LS221J	B LSDL MONOSTBL MLTVBRTR	3	25	2.97	500	†	SN74LS290N	B LS DECADE COUNTER	2	25	.56	500	†		
SN74LS221N	B LSDL MONOSTBL MLTVBRTR	1	25	.65	500	†	SN74LS293N	B LS 4-BIT BIN COUNTER	2	25	.58	500	†		
SN74LS240DW	B LS OCTAL BUFF/LINE DRV R	2	38	.32	38	†	SN74LS298N	B LS QD2I/P MUX W/STORAGE	2	25	.63	500	†		
SN74LS240DWR2	B LS OCTAL BUFF/LINE DRV R	2	1000	.32	1000	†	SN74LS299DW	B LS 8BIT SHIFT/STORAGE REG	2	38	1.24	38	†		
SN74LS240N	B LS OCTAL BUFF/LINE DRV R	1	18	.32	360	†	SN74LS299N	B LS 8BIT SHIFT/STORAGE REG	2	18	1.24	360	†		
SN74LS241N	B LS OCTAL BUFF/LINE DRV R	2	18	.50	360	†	SN74LS30D	B LS 8I/P NAND GATE	2	55	.19	55	†		
SN74LS242J	B LS QUAD BUS TRANSCEIVER	3	25	3.45	500	S †	SN74LS30DR2	B LS 8I/P NAND GATE	2	2500	.19	2500	†		
SN74LS242N	B LS QUAD BUS TRANSCEIVER	2	25	.92	500	S †	SN74LS30N	B LS 8I/P NAND GATE	1	25	.19	500	†		
SN74LS243D	B LS QUAD BUS TRANSCEIVER	2	55	.61	55	†	SN74LS32D	B LS QD2I/P OR GATE	2	55	.19	55	†		
SN74LS243N	B LS QUAD BUS TRANSCEIVER	2	25	.58	500	†	SN74LS32DR2	B LS QD2I/P OR GATE	2	2500	.19	2500	†		
SN74LS244DW	B LS OCTAL BUFF/LINE DRV R	1	38	.32	38	†	SN74LS32N	B LS QD2I/P OR GATE	1	25	.19	500	†		
SN74LS244DWR2	B LS OCTAL BUFF/LINE DRV R	2	1000	.32	1000	†	SN74LS322AN	B LS 8BIT SR W/SIGN EXTEND	2	18	1.62	360	S †		
SN74LS244J	B LS OCTAL BUFF/LINE DRV R	3	19	3.45	380	†	SN74LS33D	B LS QD2I/P NOR BUFFER	2	55	.31	55	†		
SN74LS244N	B LS OCTAL BUFF/LINE DRV R	1	18	.32	360	†	SN74LS33N	B LS QD2I/P NOR BUFFER	2	25	.27	500	†		

A = OSPD/Power
 B = Analog/Logic
 J = Transportation
 L = Consumer
 N = Networking
 V = Wireless

S = Proprietary Device
 B = Motorola Blue Chip Program Device
 P = Phoenix Program
 * = First Time in Book
 † \$200 Minimum Waived

N = Key New Motorola Device
 R = Key "Focus" Motorola Device

1 = Mature, Stable, High-Volume Device
 2 = Moderate-Volume Device
 3 = Low-Volume Device

COMMERCIAL COMPONENTS

Type No.	Grp/Description	Per Unit Sugg. Factory			
		Resale Price	Price	Order Incrmt	
PC Qty					
SN74LS348DR2	B LS8I/PPRIORITYENCODER	2	2500	.94 2500	†
SN74LS348N	B LS8I/PPRIORITYENCODER	2	25	.92 500	†
SN74LS365AD	B LS3-STATEHEXBUFFERS	2	48	.45 48	†
SN74LS365ADR2	B LS3-STATEHEXBUFFERS	2	2500	.47 2500	†
SN74LS365AN	B LS3-STATEHEXBUFFERS	2	25	.41 500	†
SN74LS367AD	B LS3-STATEHEXBUFFERS	2	48	.45 48	†
SN74LS367ADR2	B LS3-STATEHEXBUFFERS	2	2500	.47 2500	†
SN74LS367AJ	B LS3-STATEHEXBUFFERS	3	25	2.35 500	†
SN74LS367AN	B LS3-STATEHEXBUFFERS	1	25	.41 500	†
SN74LS368AN	B LS3-STATEHEXBUFFERS	2	25	.41 500	†
SN74LS373DW	B LS OCTAL TRANSPARNT LATCH	2	38	.32 38	†
SN74LS373DWR2	B LS OCTAL TRANSPARNT LATCH	2	1000	.32 1000	†
SN74LS373J	B LS OCTAL TRANSPARNT LATCH	3	19	3.51 380	†
SN74LS373N	B LS OCTAL TRANSPARNT LATCH	1	18	.32 360	†
SN74LS374DW	B LS OCTAL DFF3-STATE	1	38	.32 38	†
SN74LS374DWR2	B LS OCTAL DFF3-STATE	2	1000	.32 1000	†
SN74LS374J	B LS OCTAL DFF3-STATE	3	19	3.51 380	†
SN74LS374N	B LS OCTAL DFF3-STATE	1	18	.32 360	†
SN74LS377N	B LS OCTAL DFF W/ENABLE	1	18	.65 360	†
SN74LS378N	B LS HEX DFF W/ENABLE	2	25	.67 500	†
SN74LS38N	B LS QD2I/P NAND BUFFER	1	25	.27 500	†
SN74LS390N	B LSDL DECADE COUNTER	2	25	.52 500	†
SN74LS393D	B LSDL4-STATE BIN CNTR	2	55	.54 55	†
SN74LS393DR2	B LSDL4-STATE BIN CNTR	2	2500	.59 2500	†
SN74LS393J	B LSDL4-STATE BIN CNTR	3	25	2.79 500	†
SN74LS393N	B LSDL4-STATE BIN CNTR	1	25	.50 500	†
SN74LS399N	B LS QD2-PORT REG	2	25	.72 500	†
SN74LS42N	B LS1-OF-10 DECODER	2	25	.43 500	†
SN74LS47N	B LSCD-7SEG DEC/DRVR	2	25	.68 500	†
SN74LS48N	B LSCD TO7-SEG DECODER	2	25	.65 500	†
SN74LS490N	B LSDL DECADE COUNTER	2	25	2.07 500	†
SN74LS51D	B LSDL2WD2I/P/3I/PAOI	N	55	.19 55	†
SN74LS51N	B LSDL2WD2I/P/3I/PAOI	2	25	.19 500	†
SN74LS540N	B LS OCTAL BUFF/LNE DRVR	1	18	.72 360	†
SN74LS541DW	B LS OCTAL BUFF/LNE DRVR	2	38	.76 38	†
SN74LS541DWR2	B LS OCTAL BUFF/LNE DRVR	2	1000	.79 1000	†
SN74LS541N	B LS OCTAL BUFF/LNE DRVR	1	18	.72 360	†
SN74LS569AN	B BINARY UP/DOWN CNTR3-ST	2	18	1.44 360	S †
SN74LS623N	B LS OCTAL BUS TRANSCEIVERS	2	18	1.62 360	†
SN74LS640DW	B LS OCTAL BUS TRANSCEIVERS	2	38	1.17 38	†
SN74LS640N	B LS OCTAL BUS TRANSCEIVERS	1	18	1.17 360	†
SN74LS641N	B LS OCTAL BUS TRANSCEIVERS	2	18	1.22 360	†
SN74LS642N	B LS OCTAL BUS TRANSCEIVERS	2	18	1.22 360	†
SN74LS645N	B LS OCTAL BUS TRANSCEIVERS	1	18	.83 360	†
SN74LS669N	B LS4BIT BIN COUNTER	2	25	.72 500	†

Type No.	Grp/Description	Per Unit Sugg. Factory			
		Resale Price	Price	Order Incrmt	
PC Qty					
SN74LS670D	B LS4X4 REG FILE W/3STO/P	2	48	.81 48	†
SN74LS670DR2	B LS4X4 REG FILE W/3STO/P	2	2500	.85 2500	†
SN74LS670N	B LS4X4 REG FILE W/3STO/P	2	25	.81 500	†
SN74LS682DW	B LS8-BIT MAG COMPARATORS	2	38	1.62 38	†
SN74LS682N	B LS8-BIT MAG COMPARATORS	1	18	1.62 360	†
SN74LS684N	B LS8-BIT MAG COMPARATORS	2	18	1.98 360	†
SN74LS688DW	B LS8-BIT MAG COMPARATORS	2	38	1.57 38	†
SN74LS688DWR2	B LS8-BIT MAG COMPARATORS	2	1000	1.58 1000	†
SN74LS688N	B LS8-BIT MAG COMPARATORS	1	18	1.35 360	†
SN74LS73AN	B LSDLJK NEG EDG-TRIG FF	2	25	.38 500	†
SN74LS74AD	B LSDL DTYPE POS EDGE FF	2	55	.29 55	†
SN74LS74ADR2	B LSDL DTYPE POS EDGE FF	2	2500	.31 2500	†
SN74LS74AN	B LSDL DTYPE POS EDGE FF	1	25	.25 500	†
SN74LS76AN	B LSDLJK FF W/SET & CLEAR	2	25	.72 500	S †
SN74LS795N	B LS TRI-ST OCTAL BUFFERS	2	18	1.04 360	S †
SN74LS85D	B LS4-BIT MAG COMPARATOR	2	48	.45 48	†
SN74LS85N	B LS4-BIT MAG COMPARATOR	1	25	.41 500	†
SN74LS86D	B LS QD2I/PEXCOR	2	55	.36 55	†
SN74LS86N	B LS QD2I/PEXCOR	1	25	.25 500	†
SN74LS90DR2	B LS DECADE COUNTER	2	2500	.52 2500	†
SN74LS90J	B LS DECADE COUNTER	3	25	2.35 500	†
SN74LS90N	B LS DECADE COUNTER	2	25	.45 500	†
SN74LS92DR2	B LS DIVIDE BY 12 COUNTER	2	2500	.52 2500	†
SN74LS92N	B LS DIVIDE BY 12 COUNTER	2	25	.45 500	†
SN74LS93N	B LS4-BIT BIN COUNTER	1	25	.41 500	†
SPAKB56007FJ50	L 24-BIT AUDIO DSP	N	2	31.61	2 S B
SPAKB56007FJ66	L 24-BIT AUDIO DSP	N	2	31.61	2 S B
SPAKDSP56002PV40	N 1C MONOLITHIC 40MHZ DSP	N	2	28.01	2 B
SPAKDSP56002PV66	N DSP24-BIT TQFP FXDPT.	N	2	28.01	2 B
SPAKDSP56002PV80	N DSP56002	N	2	28.01	2 B
SPAKDSP56004FJ50	L DSP24-BIT DIGITAL AUDIO	N	2	20.31	2 S B
SPAKDSP56004FJ66	L 24-BIT AUDIO DSP	N	1	25.04	1 S B
SPAKXC56007FJ40	L DSP-SPEAKERPHONE	N	2	35.01	2 S B
SPAKXC561811BU40	V 16-BIT, RAM-BASED, HAWK DSP	N	2	18.11	2 * S B
SPAKXC56004FJ50	L DSP	N	2	22.51	2 S B
SPAKXC56004FJ66	L DSP24-BIT AUDIO DSP	N	2	25.04	2 S B
SPAKXC56301GC66	N REFERENCE XC56301GC66	N	2	76.63	2 B
SPAKXC56301GC80	N 24BIT-HIGH PERFORMANCE	N	2	76.63	2 B
SPAKXC56301PW66	N 24BIT HIGH REFORMANCE DSP	N	2	76.63	2 B
SPAKXC56301PW80	N REFERENCE XC56301PW80	N	2	76.63	2 B
SPAKXC56302PV66	N 24-BIT PERF.DSP	N	2	129.05	2 * B
SPAKXC56303GC66	N 24 BIT HIGH PERF. DSP	N	2	56.02	2 * B
SPAKXC56303GC80	N 24 BIT HI-PERF DSP	N	2	56.02	2 * B
SPAKXC56303PV66	N REFERENCE XC56303PV66	N	2	56.02	2 B
SPAKXC56303PV80	N REFERENCE XC56303PV80	N	2	56.02	2 B

A = OSPD/Power
 B = Analog/Logic
 J = Transportation
 L = Consumer
 N = Networking
 V = Wireless

S = Proprietary Device
 B = Motorola Blue Chip Program Device
 P = Phoenix Program
 * = First Time in Book
 † \$200 Minimum Waived

N = Key New Motorola Device
 R = Key "Focus" Motorola Device

1 = Mature, Stable, High-Volume Device
 2 = Moderate-Volume Device
 3 = Low-Volume Device

COMMERCIAL COMPONENTS

Type No.	Grp/Description	Per PC	Unit Qty	Sugg- Resale Price	Factory Order Incrmnt	Type No.	Grp/Description	Per PC	Unit Qty	Sugg- Resale Price	Factory Order Incrmnt
SPMCK16Y1BGCFT16	J AMCU	N	2	21.64	2 B	TCA0372DP2	B DUAL POWER OP AMP	N	25	.90	25 †
SPMCKL332ACFC16	J 32BIT,MCU,2KRAM,TPU,QSM	N	2	16.52	2★ B	TCA3385-DP	L RING SIGNAL CONVERTER	N	50	2.21	50 S P
SPMCKL332ACPV16	J 32BIT,MCU,2KRAM,TPU,QSM	N	2	14.33	2★ B	TCF5600	J POWER SUPPLY CONTROLLER	N	20	6.73	20
SPMCKL332GCFC16	J 32BIT,MCU,2KRAM,TPU,QSM	N	2	16.52	2★ B	TCF6000	J LIN PERIPHERAL CLMPGARRY	1	50	2.07	50 S P
SPMCKL332GCPV16	J 32BIT,MCU,2KRAM,TPU,QSM	N	2	14.33	2★ B	TCF6000D	J LIN PERIPHERAL CLMPGARRY	N	98	2.07	98 S
SPMCM16Y1BGCFT16	J AMCU	N	2	21.40	2 B	TCF6000DR2	J CLAMPING ARRAY	2	2500	2.11	2500 S
SPMC16S2CPU20	J 8 BIT MCU	N	2	6.93	2★ B	TDA1185A	B LIN TRIAC PHASE ANG CNTRL	N	25	1.96	25 S P †
SPMC16V1CPU20	J 16 BIT MCU,GPT,100 TOFP	N	2	8.44	2 B	TIL111	A OPTOISO XTR6-PINDIP	2	50	.62	50 †
SPMC16Z1CFC16	J 16BIT MCU, RAM, 10BIT A/D	N	2	11.88	2 B	TIL113	A OPTOISO DARL6-PINDIP	2	50	.62	50 †
SPMC16Z1CFC20	J AMCU	N	2	12.47	2 B	TIL117	A OPTOISO XTR6-PINDIP	2	50	.62	50 †
SPMC16Z1CFC25	J 16BIT MCU, RAM, 10BIT A/D	N	2	13.07	2 B	TIP100	A PWR8A60V NPND TO220	1	50	.70	50 †
SPMC16Z1CPV16	J 16 BIT MCU RAM, 10 BIT A/D	N	2	9.68	2 B	TIP101	A PWR8A80V NPND TO220	2	50	.70	50 †
SPMC16Z1CPV20	J 16 BIT MCU, RAM, 10 BIT A/D	N	2	10.17	2 B	TIP102	A PWR8A100V NPND TO220	1	50	.70	50 †
SPMC16Z1CPV25	J MMCU	N	2	10.65	2 B	TIP105	A PWR8A60V PNP TO220	2	50	.70	50 †
SPMC16Z2BCFC16	J AMCU16BIT MCU2KSRAM	N	2	17.32	2 B	TIP106	A PWR8A80V PNP TO220	2	50	.70	50 †
SPMC16Z2BCFC20	J AMCU16BIT2K SRAM	N	2	18.81	2 B	TIP107	A PWR8A100V PNP TO220	1	50	.70	50 †
SPMC16Z2BCPV16	J AMCU16BIT MCU2KSRAM	N	2	15.13	2 B	TIP110	A PWR2A60V NPND TO220	1	50	.60	50 †
SPMC16Z2BCPV20	J AMCU16BIT2K SRAM	N	2	16.26	2 B	TIP111	A PWR2A80V NPND TO220	1	50	.60	50 †
SPMC16Z3KACFC16	J 16BIT MCU, WRTEK, 2KRAM, A/D	N	36	15.61	36★ B	TIP112	A PWR2A100V NPND TO220	1	50	.60	50 †
SPMC68CK331CFC16	J 32BIT HCMOS WIREBOND	N	2	14.88	2★ B	TIP115	A PWR2A60V PNP TO220	1	50	.56	50 †
SPMC68CK331CPV16	J 32BIT HCMOS WIREBOND	N	2	12.68	2★ B	TIP116	A PWR2A80V PNP TO220	2	50	.56	50 †
SPMC68331CFC16	J BIT MCU, GPT, SIM, QSM	N	2	13.13	2 B	TIP117	A PWR2A100V PNP TO220	1	50	.60	50 †
SPMC68331CFC20	J 32BIT MCU, GPT, SIM, QSM	N	2	13.79	2 B	TIP120	A PWR8A60V NPND TO220	1	50	.60	50 †
SPMC68331CFC25	J MMCU	N	2	14.45	2 B	TIP121	A PWR5A80V NPND TO220	1	50	.60	50 †
SPMC68331CPV16	J AMCU	N	2	10.94	2 B	TIP122	A PWR8A100V NPND TO220	1	50	.60	50 †
SPMC68331CPV20	J AMCU	N	2	11.48	2 B	TIP125	A PWR8A60V PNP TO220	1	50	.66	50 †
SPMC68331CPV25	J MMCU	N	2	12.03	2 B	TIP126	A PWR8A80V PNP TO220	1	50	.66	50 †
SPMC68332ACFC16	J 32BIT MCU, 2KRAM, TPU, QSM	N	2	14.31	2 B	TIP127	A PWR8A100V PNP TO220	1	50	.66	50 †
SPMC68332ACFC20	J 32BIT MCU, 2KRAM, TPU, QSM	N	2	15.03	2 B	TIP140	A PWR10A60V NPND TO218	1	30	1.90	30
SPMC68332ACFC25	J MMCU	N	2	15.74	2 B	TIP141	A PWR10A80V NPND TO218	2	30	1.90	30
SPMC68332ACPV16	J AMCU	N	2	12.11	2 B	TIP142	A PWR10A100V NPND TO218	1	30	1.92	30
SPMC68332ACPV20	J AMCU	N	2	12.72	2 B	TIP145	A PWR10A60V PNP TO218	2	30	1.90	30
SPMC68332ACPV25	J MMCU	N	2	13.32	2 B	TIP146	A PWR10A80V PNP TO218	2	30	1.90	30
SPMC68332GCFC16	J 32BIT MCU, 2KRAM, TPU, QSM	N	2	14.31	2 B	TIP147	A PWR10A100V PNP TO218	1	30	1.92	30
SPMC68332GCFC20	J 32BIT MCU, 2KRAM, TPU, QSM	N	2	15.03	2 B	TIP29	A PWR1A40V NPN TO220	2	50	.54	50 †
SPMC68332GCFC25	J MMCU	N	2	15.74	2 B	TIP29A	A PWR1A60V NPN TO220	2	50	.54	50 †
SPMC68332GCPV16	J AMCU	N	2	12.11	2 B	TIP29B	A PWR1A80V NPN TO220	2	50	.54	50 †
SPMC68332GCPV20	J AMCU	N	2	12.72	2 B	TIP29C	A PWR1A100V NPN TO220	1	50	.54	50 †
SPMC68332GCPV25	J MMCU	N	2	13.32	2 B	TIP2955	A PWR15A60V PNPTO218	2	30	1.32	30
SPMC916R1CFC16	J 16BIT MCU W/50K F/EEPROM	N	2	31.49	2★ B	TIP30	A PWR1A40V PNP TO220	1	50	.54	50 †
SPMC916Y3CFT16	J AMCU16BIT MCU	N	2	54.15	2★ B	TIP30A	A PWR1A60V PNP TO220	2	50	.54	50 †
SPXCM916X1CTH16	J AMCU	N	2	22.96	2 B	TIP30B	A PWR1A80V PNP TO220	2	50	.54	50 †
SPXC68F333ACFT16	J 32BIT AMCU, 64K FLASH EE	N	2	27.46	2 B	TIP30C	A PWR1A100V PNPTO220	1	50	.54	50 †
SPXPC505FT25	J AMCU	N	2	29.00	2 B	TIP3055	A PWR15A60V NPN TO218	2	30	1.22	30
TCA0372DP1	B DUAL POWER OP AMP	2	1000	.90	1000 †	TIP31	A PWR3A40V NPN TO220	1	50	.54	50 †

A = OSPD/Power
 B = Analog/Logic
 J = Transportation
 L = Consumer
 N = Networking
 V = Wireless

S = Proprietary Device
 B = Motorola Blue Chip Program Device
 P = Phoenix Program
 ★ = First Time in Book
 † \$200 Minimum Waived

N = Key New Motorola Device
 R = Key "Focus" Motorola Device

1 = Mature, Stable, High-Volume Device
 2 = Moderate-Volume Device
 3 = Low-Volume Device

EFFECTIVE DATE: JANUARY 10, 1998

COMMERCIAL COMPONENTS

Type No.	Grp/Description	Per Unit Sugg. Factory				
		Resale Price	Price	Order		
PC	Qty	Price	Incrmnt			
TIP31A	A PWR3A60V NPN TO220	1	50	.54	50	†
TIP31B	A PWR3A80V NPN TO220	2	50	.54	50	†
TIP31C	A PWR3A100V NPN TO220	1	50	.54	50	†
TIP32	A PWR3A40V PNP TO220	1	50	.54	50	†
TIP32A	A PWR3A60V PNP TO220	2	50	.54	50	†
TIP32B	A PWR3A80V PNP TO220	2	50	.54	50	†
TIP32C	A PWR3A100V PNP TO220	1	50	.54	50	†
TIP33A	A PWR10A60V NPN TO218	2	30	1.24	30	
TIP33C	A PWR10A100V NPN TO218	2	30	1.30	30	
TIP35C	A PWR25A100V NPN TO218	1	30	2.12	30	
TIP36A	A PWR25A60V PNP TO218	2	30	1.68	30	
TIP36C	A PWR25A100V PNP TO218	1	30	2.12	30	
TIP41	A PWR6A40V NPN TO220	2	50	.64	50	†
TIP41A	A PWR6A60V NPN TO220	2	50	.64	50	†
TIP41B	A PWR6A80V NPN TO220	2	50	.64	50	†
TIP41C	A PWR6A100V NPN TO220	1	50	.64	50	†
TIP42	A PWR6A40V PNP TO220	1	50	.62	50	†
TIP42A	A PWR6A60V PNP TO220	2	50	.62	50	†
TIP42B	A PWR6A80V PNP TO220	2	50	.62	50	†
TIP42C	A PWR6A100V PNP TO220	1	50	.62	50	†
TIP47	A PWR1A250V NPN TO220	1	50	.64	50	
TIP48	A PWR1A300V NPN TO220	1	50	.66	50	
TIP50	A PWR1A400V NPN TO220	1	50	.76	50	
TL062ACD	B LINLOPWR JFET INPT O.A.	2	98	.92	98	†
TL062ACP	B LINLOPWR JFET INPT O.A.	2	50	.77	1000	†
TL062CD	B LINLOPWR JFET INPT O.A.	N	98	.48	98	†
TL062CDR2	B LIN DUAL JFET OP AMP	2	2500	.61	2500	†
TL062CP	B LINLOPWR JFET INPT O.A.	2	50	.58	1000	†
TL062VD	B LINLOPWR JFET INPT O.A.	3	98	2.45	98	†
TL062VP	B LINLOPWR JFET INPT O.A.	3	50	2.45	1000	†
TL064ACD	B LINLOPWR JFET INPT O.A.	N	55	.88	55	†
TL064ACN	B LINLOPWR JFET INPT O.A.	N	25	1.61	500	†
TL064CD	B LINLOPWR JFET INPT O.A.	N	55	.77	55	†
TL064CDR2	B LINOP AMP	2	2500	.94	2500	†
TL064CN	B LINLOPWR JFET INPT O.A.	2	25	1.40	500	†
TL064VD	B LINLOPWR JFET INPT O.A.	3	55	3.33	55	†
TL064VN	B LINLOPWR JFET INPT O.A.	3	25	3.33	500	†
TL071ACD	B LINLO NOISE JFT INPT AMP	N	98	.48	98	†
TL071ACP	B LINLO NOISE JFT INPT AMP	2	50	.59	1000	†
TL071CD	B LINLO NOISE JFT INPT AMP	N	98	.48	98	†
TL071CP	B LINLO NOISE JFT INPT AMP	2	50	.58	1000	†
TL072ACD	B LINLO NOISE JFT INPT AMP	N	98	.58	98	†
TL072ACDR2	B LO NOISE JFET INPT OP AMP	N	2500	.58	2500	†
TL072ACP	B LINLO NOISE JFT INPT AMP	2	50	.87	1000	†
TL072CD	B LINLO NOISE JFT INPT AMP	N	98	.51	98	†

Type No.	Grp/Description	Per Unit Sugg. Factory				
		Resale Price	Price	Order		
PC	Qty	Price	Incrmnt			
TL072CDR2	B LO NOISE JFET INPT OP AMP	2	2500	.61	2500	†
TL072CP	B LINLO NOISE JFT INPT AMP	1	50	.58	1000	†
TL074ACN	B LINLO NOISE JFT INPT AMP	N	25	1.07	500	†
TL074CN	B LINLO NOISE JFT INPT AMP	2	25	.93	500	†
TL081ACD	B LINJFET INPUT OP AMP	N	98	.51	98	†
TL081ACP	B LINJFET INPUT OP AMP	N	50	.57	1000	†
TL081CD	B LINJFET INPUT OP AMP	N	98	.51	98	†
TL081CP	B LINJFET INPUT OP AMP	2	50	.75	1000	†
TL082ACD	B LINJFET INPUT OP AMP	N	98	.51	98	†
TL082ACP	B LINJFET INPUT OP AMP	2	50	.62	1000	†
TL082CD	B LINJFET INPUT OP AMP	2	98	.48	98	†
TL082CDR2	B JFET INPT OP AMP	2	2500	.62	2500	†
TL082CP	B LINJFET INPUT OP AMP	1	50	.75	1000	†
TL084ACN	B LINJFET INPUT OP AMP	2	25	.75	500	†
TL084CN	B LINJFET INPUT OP AMP	1	25	.68	500	†
TL431ACD	B LINPROG. PREC REF.	2	98	.45	98	†
TL431ACDR2	B PROG PREC REF	2	2500	.53	2500	†
TL431ACLP	B LINPROG PRECISION REF	1	2000	.44	2000	†
TL431ACP	B LINPROG PRECISION REF	2	50	.65	1000	†
TL431AID	B LINPROG. PREC REF.	2	98	.62	98	†
TL431AIDR2	B PROG PREC REF	2	2500	.62	2500	†
TL431AILP	B LINPROG PRECISION REF	2	2000	.58	2000	†
TL431AILPRM	B PRGRMBLE PRECISION REF	N	2000	.58	2000	★
TL431AIP	B LINPROG PRECISION REF	2	50	.51	1000	†
TL431BCD	B PROGRAM PRECISION REF	2	98	.58	98	†
TL431BCLP	B PROGRAM PRECISION REF	2	2000	.59	2000	†
TL431BID	B PROGRAM PRECISION REF	2	98	.70	98	†
TL431BIP	B PROGRAM PRECISION REF	2	50	.71	1000	†
TL431CD	B LINPROGRMBL PRCSN REFRNC	1	98	.39	98	†
TL431CDR2	B LINPROG PRCSN REF T/R	2	2500	.62	2500	†
TL431CLP	B LINPROGRMBL PRCSN REFRNC	1	2000	.39	2000	†
TL431CP	B LINPROGRMBL PRCSN REFRNC	2	50	.39	1000	†
TL431ID	B LINPROG PRCSN REF	2	98	.58	98	†
TL431ILP	B LINPROGRMBL PRCSN REFRNC	1	2000	.46	2000	†
TL431ILPRA	B PRGRMBLE PRECISION REF	2	2000	.49	2000	†
TL431IP	B LINPROGRMBL PRCSN REFRNC	N	50	.69	1000	†
TL494CN	B LINSWTCHMDE PWM CONT CKT	2	25	.68	500	†
TL594CN	B LINPRC SWMD PWM CONT CKT	N	25	.68	500	†
TL780-05CKC	B LAST ORDER DATE:06/30/98	1	50	.64	50	†
TL780-12CKC	B LAST ORDER DATE:06/30/98	2	50	.64	50	†
TL780-15CKC	B LAST ORDER DATE:06/30/98	2	50	.64	50	†
TPV595A	N RF NPN HI PWR P-P FLANGE	2	20	210.00	20	
TPV597	N RF NPN HI PWR SOE STUD	2	20	36.30	20	
TPV598	N RF NPN HI PWR SOE STUD	2	20	118.00	20	
TPV8100B	N SILICON RF TRANS	N	20	346.50	20	

A = OSPD/Power
 B = Analog/Logic
 J = Transportation
 L = Consumer
 N = Networking
 V = Wireless

S = Proprietary Device
 B = Motorola Blue Chip Program Device
 P = Phoenix Program
 ★ = First Time in Book
 † \$200 Minimum Waived

N = Key New Motorola Device
 R = Key "Focus" Motorola Device

1 = Mature, Stable, High-Volume Device
 2 = Moderate-Volume Device
 3 = Low-Volume Device

COMMERCIAL COMPONENTS

Type No.	Grp/Description	Per Unit Sugg. Factory				†	Type No.	Grp/Description	Per Unit Sugg. Factory				†
		PC	Qty	Price	Order				PC	Qty	Price	Order	
T2322B	A TRIAC2.5A200V CASE77	2	500	.56	500	†	UC3843BVN	B PWM CONTROLLER	2	50	1.03	1000	†
T2500D	A TRIAC6A400V TO220	1	500	.76	500	†	UC3844BD	B CURRENT MODE CONTROLLER	N	55	1.03	55	†
T2500DFP	A TRIAC6A400V ISO TO220	2	500	1.38	500	†	UC3844BD1	B CURRENT MODE CONTROLLER	N	98	1.53	98	†
T2800D	A TRIAC8A400V TO220	1	500	.82	500	†	UC3844BN	B CURRENT MODE CONTROLLER	N	50	1.03	1000	†
UAA1041B	J AUTO DIRECTION INDICATOR	N	50	.73	50		UC3844BVD	B PWM CONTROLLER	2	55	1.03	55	†
UAA2016P	B ZERO VOLT SWITCH PWR CTR	N	50	1.52	50	†	UC3844BVD1	B PWM CONTROLLER	N	98	1.53	98	†
UA78S40PC	B LIN UNIV SWIT REG SUBSYS	1	25	1.19	500	†	UC3844BVN	B PWM CONTROLLER	N	50	1.53	1000	†
UA78S40PV	B LIN UNIV SWIT REG SUBSYS	N	25	1.19	500	†	UC3844D	B LIN CURNT MD SWTCHNG REG	3	55	2.31	55	†
UC2842AD	B LIN HI-PRF CRNT-MDE CNTRL	N	55	1.66	55	†	UC3844N	B LIN CURNT MD SWTCHNG REG	1	50	.97	1000	†
UC2842AN	B LIN HI-PRF CRNT-MDE CNTRL	2	50	1.12	1000	†	UC3845BD	B CURRENT MODE CONTROLLER	N	55	1.03	55	†
UC2842BD	B CURRENT MODE CONTROLLER	N	55	1.04	55	†	UC3845BD1	B CURRENT MODE CONTROLLER	N	98	1.53	98	†
UC2842BD1	B CURRENT MODE CONTROLLER	N	98	1.55	98	†	UC3845BN	B CURRENT MODE CONTROLLER	N	50	1.03	1000	†
UC2843AD	B LIN HI-PRF CRNT-MDE CNTRL	N	55	1.12	55	†	UC3845BVD	B PWM CONTROLLER	2	55	1.03	55	†
UC2843AN	B LIN HI-PRF CRNT-MDE CNTRL	2	50	1.12	1000	†	UC3845BVD1	B PWM CONTROLLER	N	98	1.53	98	†
UC2843BD	B CURRENT MODE CONTROLLER	N	55	1.44	55	†	UC3845BVN	B PWM CONTROLLER	2	50	1.03	1000	†
UC2843BD1	B CURRENT MODE CONTROLLER	N	98	1.55	98 *	†	UC3845D	B LIN CRNT SWTCH REG CNTRL	N	55	.97	55	†
UC2843BD1R2	B CURRENT MODE CONTROLLER	N	2500	1.55	2500 *	†	UC3845DR2	B LIN CRNT SWTCH REG CNTRL	2	2500	1.00	2500	†
UC2843BN	B CURRENT MODE CONTROLLER	N	50	1.74	1000	†	UC3845N	B LIN CRNT SWTCH REG CNTRL	2	50	.97	1000	†
UC2844BD	B CURRENT MODE CONTROLLER	N	55	1.12	55	†	ULN2803A	B LIN OCTAL PERI DRVR ARRAY	1	20	.65	20	†
UC2844BDR2	B CURRENT MODE CONTROLLER	N	2500	1.12	2500 *	†	ULN2804A	B LIN OCTAL PERI DRVR ARRAY	1	20	.65	20	†
UC2844BN	B CURRENT MODE CONTROLLER	N	50	1.12	1000 *	†	VN0610LL	A SSTMOSN-CHAN TO-92	3	1000	1.00	1000	†
UC2844D	B LIN CURNT MD SWTCHNG REG	3	55	3.04	55	†	VN10LM	A SSTMOSN-CHAN TO-92	2	1000	.70	1000	†
UC2844N	B LIN CURNT MD SWTCHNG REG	2	50	1.66	1000	†	VN10MLRRA	A REEL PACK FOR VN10LM	2	2000	.70	2000	†
UC2845BD	B CURRENT MODE CONTROLLER	N	55	1.44	55	†	VN2222LL	A SSTMOSN-CH TO-92 FET	1	1000	.50	1000	†
UC2845BDR2	B CURRENT MODE CONTROLLER	2	2500	1.55	2500	†	VN2222LLRL	A TMOS FET/NCHAN-T/R	2	2000	.50	2000	†
UC2845BN	B CURRENT MODE CONTROLLER	N	50	1.35	1000 *	†	VN2222LLRLRA	A SSTMOSN-CH TO-92 T/R	2	2000	.50	2000	†
UC2845D	B LIN CRNT SWTCH REG CNTRL	3	55	3.04	55	†	VN2406L	A SSTMOSN-CH TO-92 FET	2	1000	.90	1000	†
UC2845N	B LIN CRNT SWTCH REG CNTRL	2	50	1.28	1000	†	VN2410L	A SSTMOSN-CH TO-92 FET	3	1000	1.80	1000	†
UC3842AD	B LIN HI-PRF CRNT-MDE CNTRL	N	55	.97	55	†	XCB56007FJ40	L DSP-SPEAKERPHONE	N	84	29.59	84	S B
UC3842AN	B LIN HI-PRF CRNT-MDE CNTRL	1	50	.97	1000	†	XCB56007FJ66	L DSP-SPEAKERPHONE	N	84	31.48	84	S B
UC3842BD	B CURRENT MODE CONTROLLER	N	55	1.03	55	†	XCB56007FJ88	L 24-BIT AUDIO DSP	N	84	30.33	84	S B
UC3842BD1	B CURRENT MODE CONTROLLER	N	98	1.46	98	†	XCF5102PV20A	L 1ST GENERATION 5U32 BIT	N	60	16.84	60	B
UC3842BN	B CURRENT MODE CONTROLLER	N	50	1.03	1000	†	XCF5102PV25A	L COLD FIRE BRIDGE TO EC040	N	60	19.65	60	B
UC3842BVD	B PWM CONTROLLER	N	55	1.53	55	†	XCM916X1CTH16	J 16-BIT MCU, 2KRAM, 50K FLAS	N	50	22.46	50	B
UC3842BVD1	B PWM CONTROLLER	N	98	1.53	98	†	XCM916X1CTH16B1	J MCU	N	250	21.95	250	B
UC3842BVN	B PWM CONTROLLER	N	50	1.53	1000	†	XC33215B	L SPEAKERPHONE	N	1	5.51	1	S P
UC3843AD	B LIN HI-PRF CRNT-MDE CNTRL	N	55	1.12	55	†	XC33215FB	L SPEAKERPHONE CHIP	N	96	5.74	480	S P
UC3843ADR2	B LIN HI-PRF CRNT-MDE CNTRL	N	2500	1.12	2500 *	†	XC56L811BU40	V 16-BIT, RAM-BASED, HAWK DSP	N	84	9.99	84	S B
UC3843AN	B LIN HI-PRF CRNT-MDE CNTRL	1	50	.97	1000	†	XC56004FJ50	L DSP	N	84	19.06	84	S B
UC3843BD	B CURRENT MODE CONTROLLER	N	55	1.03	55	†	XC56004FJ66	L DSP 24-BIT AUDIO DSP	N	84	20.95	84	S B
UC3843BD1	B CURRENT MODE CONTROLLER	N	98	1.03	98	†	XC56301GC66	N 24 BIT HI-PERF DSP PBGA	N	60	40.33	60	B
UC3843BN	B CURRENT MODE CONTROLLER	N	50	1.53	1000	†	XC56301GC80	N 24 BIT HIGH PERFORMANCE DSP	N	60	44.33	60	B
UC3843BVD	B PWM CONTROLLER	2	55	1.03	55	†	XC56301PW66	N NO SAMPLE ORDERS ALLOWED	N	36	40.33	36	B
UC3843BVD1	B PWM CONTROLLER	2	2500	1.45	2500	†	XC56301PW80	N 24 BIT HIGH PERFORMANCE DSP	N	36	44.33	36	B
UC3843BVD1	B PWM CONTROLLER	N	98	1.53	98	†	XC56302PV66	N NO SAMPLE ORDERS ALLOWED	N	60	66.55	60	B

A = OSPD/Power
 B = Analog/Logic
 J = Transportation
 L = Consumer
 N = Networking
 V = Wireless

S = Proprietary Device
 B = Motorola Blue Chip Program Device
 P = Phoenix Program
 * = First Time in Book
 † = \$200 Minimum Waived

N = Key New Motorola Device
 R = Key "Focus" Motorola Device

1 = Mature, Stable, High-Volume Device
 2 = Moderate-Volume Device
 3 = Low-Volume Device

COMMERCIAL COMPONENTS

Type No.	Grp/Description	Per Unit Sugg.		Factory Order	Incrmnt
		Resale Price	Price		
XC56303GC66	N 24-BITHI-PERF DSP	N 126	27.51	126	B
XC56303GC80	N 24-BITHI-PERF DSP	N 126	30.22	126	B
XC56303PV66	N 24 BITHI-PERF DSP	N 60	27.51	60	B
XC56303PV80	N 24BIT HIGH PERFDSP	N 60	30.22	60	B
XC56603PV60	V LOWPOWER1XDSP32KRAM	N 60	38.96	60	S B
XC68F333ACFT16	J 32 BIT AMCU,64K FLASH EE	N 24	26.96	24	B
XC68F333ACFT16B1	J 32 BIT AMCU,64K FLASH EE	N 120	26.45	120	B
XC68HC12A0CPV8	J CMSD	N 60	7.02	60	★ B
XC68HC705D32ACFN	L CSIC MCU	N 26	7.95	26	B
XC68HC705D32ACFS	L CSIC MCU	N 26	45.02	26	
XC68HC705D32ACP	L CSIC MCU	N 9	7.95	9	B
XC68HC705D32ACS	L CSIC MCU	N 9	45.02	9	
XC68HC705F6FU	L 8BIT MCU	N 50	12.95	1	
XC68HC705JB2P	L CSIC MCU	N 1	3.24	1	★
XC68HC705JJ7CDW	J CSIC MCU	N 38	2.51	38	B
XC68HC705JJ7CP	J CSIC MCU	N 20	2.51	20	B
XC68HC705JP7CDW	J CSIC MCU	N 26	2.60	26	B
XC68HC705JP7CP	J CSIC MCU	N 13	2.60	13	B
XC68HC705KJ1CDW	L CSIC MCU	N 47	.95	47	★ B
XC68HC705KJ1CP	L CSIC MCU	N 25	1.20	25	★ B
XC68HC705KJ1CS	L CSIC MCU	N 25	26.60	25	★
XC68HC705L1B	L 8BIT MCU	N 9	6.95	9	B
XC68HC705L1FU	L 8BIT MCU	2 50	6.95	1	B
XC68HC705MC4CDW	J MTR CONT3.5K EPR176BRM	N 26	6.95	26	B
XC68HC705MC4CP	J MTR CONT3.5K EPR176BRM	N 13	6.95	13	B
XC68HC705P6ACDW	J CSIC MCU	N 26	2.15	26	B
XC68HC705P6ACP	J CSIC MCU	N 13	2.15	13	B
XC68HC705RC16DW	L CSIC-RC16 OTP28 PIN SOIC	N 26	6.11	26	B
XC68HC705RC16FN	L CSIC MCU	N 26	6.11	26	B
XC68HC705RC16P28	L CSIC-RC16 OTP28 PIN DIP	N 26	6.11	26	B
XC68HC708MP16CFU	J CSIC MCU	N 84	8.00	84	★ B
XC68HC708XL36CB	L CSIC MCU	N 1	8.95	1	B
XC68HC708XL36CFU	L CSIC MCU	N 84	8.95	84	B
XC68HC711E9CFS2	J 8-BITEPROM,512RAM,A/D,EE	1 1	25.34	1	B
XC68HC711E9CFS3	J 8-BITEPROM,512RAM,A/D,EE	2 1	29.26	1	B
XC68HC711E9MFS2	J 8-BIT AMCU	N 23	30.40	23	★ B
XC68HC711K4CFS3	J 8-BITEPROM,768RAM,A/D,EE	N 1	54.21	1	★ B
XC68HC711K4CFS4	J 8-BITEPROM,768RAM,A/D,EE	N 1	60.72	1	★ B
XC68HC711L6CFS2	J 8-BITEPROM,512RAM,A/D,EE	N 1	31.53	1	★ B
XC68HC711L6CFS3	J 8-BITEPROM,512RAM,A/D,EE	N 1	35.30	1	★ B
XC68HC711P2CFS3	J AMCU	N 1	57.90	1	★ B
XC68HC805K3CDW	J CSIC MCU	N 47	2.45	47	B
XC68HC805K3CP	J CSIC MCU	N 25	2.45	25	B
XC68HC805P18CDW	J CSIC MCU DEVICE P SERIES	N 26	4.60	26	B
XC68HC805P18CP	J CSIC MCU DEVICE P SERIES	N 13	4.60	13	B

Type No.	Grp/Description	Per Unit Sugg.		Factory Order	Incrmnt
		Resale Price	Price		
XC68HC812A4CPV8	J CMSD	N 60	9.12	60	B
XC68HC912B32CFU8	J 16BIT HCMOS MCU W/FLASH	N 84	15.66	84	★ B
XC812A4CPV8B1	J CMSD	N 300	8.12	300	B
XPC505FT25	J 32-BIT RISC MCU,4KRAM,FPU	N 24	21.84	24	B
1.5KE10CA	A ZEN10V5%CLIPPER	3 500	1.92	500	†
1.5KE100A	A ZEN100V1500W5%C41-11	3 500	1.93	500	†
1.5KE11A	A ZEN11V1500W5%C41-11	2 500	.77	500	†
1.5KE11ARL4	A ZENER DIODE T/R	2 1500	.68	1500	†
1.5KE11CA	A H/PWRSURMTRANS SUP	N 500	.96	500	†
1.5KE110A	A ZEN110V1500W5%C41-11	2 500	1.12	500	†
1.5KE110CA	A ZEN110V1500W5%CLIPPER	N 500	1.58	500	†
1.5KE110CARL4	A HPSURMETIC TRANS SUPPRESS	2 1500	2.16	1500	†
1.5KE12A	A ZEN12V1500W5%C41-11	3 500	1.36	500	†
1.5KE12CA	A ZEN12V5%CLIPPER	2 500	.96	500	†
1.5KE120CA	A ZEN120V1500W5%CLIPPER	2 500	1.58	500	†
1.5KE13A	A ZEN13V1500W5%C41-11	3 500	1.40	500	†
1.5KE130A	A ZEN130V1500W5%C41-11	2 500	1.12	500	†
1.5KE130CA	A ZEN130V5%CLIPPER	2 500	1.58	500	†
1.5KE15A	A ZEN15V1500W5%C41-11	2 500	.69	500	†
1.5KE15ARL4	A ZENER DIODE T/R	2 1500	.69	1500	†
1.5KE15CA	A ZEN15V5%CLIPPER	2 500	.96	500	†
1.5KE150CA	A ZEN150V1500W5%CLIPPER	2 500	1.58	500	†
1.5KE16A	A ZEN16V1500W5%C41-11	2 500	.68	500	†
1.5KE16CA	A ZEN16V5%CLIPPER	3 500	1.92	500	†
1.5KE160A	A ZEN160V1500W5%C41-11	2 500	1.12	500	†
1.5KE160CA	A ZEN160V5%CLIPPER	3 500	2.73	500	†
1.5KE160CARL4	A HIPWR SURMETIC TRANS SUP	2 1500	2.16	1500	†
1.5KE170CA	A ZEN170V1500W5%CLIPPER	N 500	1.58	500	†
1.5KE170CARL4	A HIPWR SURMETIC TRANS SUP	2 1500	2.16	1500	†
1.5KE18A	A ZEN18V1500W5%C41-11	2 500	.68	500	†
1.5KE18ARL4	A ZENER DIODE T/R	2 1500	.68	1500	†
1.5KE18CA	A ZEN18V5%CLIPPER	2 500	.96	500	†
1.5KE180A	A ZEN180V1500W5%C41-11	3 500	1.93	500	†
1.5KE180ARL4	A ZENER DIODE T/R	2 1500	1.12	1500	†
1.5KE180CA	A ZEN180V5%CLIPPER	3 500	3.27	500	†
1.5KE20A	A ZEN20V1500W5%C41-11	2 500	.68	500	†
1.5KE20ARL4	A ZENER DIODE T/R	2 1500	.68	1500	†
1.5KE20CA	A ZEN20V5%CLIPPER	2 500	.96	500	†
1.5KE200A	A ZEN200V1500W5%C41-11	2 500	1.12	500	†
1.5KE200ARL4	A ZENER DIODE T/R	2 1500	1.12	1500	†
1.5KE200CA	A ZEN200V5%CLIPPER	3 500	3.27	500	†
1.5KE22A	A ZEN22V1500W5%C41-11	2 500	.68	500	†
1.5KE22ARL4	A ZENER DIODE T/R	2 1500	.68	1500	†
1.5KE22CA	A ZEN22V5%CLIPPER	2 500	.96	500	†
1.5KE220A	A ZEN220V1500W5%C41-11	2 500	1.12	500	†

A = OSPD/Power
 B = Analog/Logic
 J = Transportation
 L = Consumer
 N = Networking
 V = Wireless

S = Proprietary Device
 B = Motorola Blue Chip Program Device
 P = Phoenix Program
 ★ = First Time in Book
 † \$200 Minimum Waived

N = Key New Motorola Device
 R = Key "Focus" Motorola Device

1 = Mature, Stable, High-Volume Device
 2 = Moderate-Volume Device
 3 = Low-Volume Device

EFFECTIVE DATE: JANUARY 10, 1998

COMMERCIAL COMPONENTS

Type No.	Grp/Description	Per PC	Unit Qty	Sugg. Price	Factory Order	Incrrmnt
1.5KE220CA	A ZEN220V5%CLIPPER	2	500	1.58	500	†
1.5KE24CA	A ZEN24V5%CLIPPER	2	500	.96	500	†
1.5KE250A	A ZEN250V1500W5%C41-11	2	500	1.12	500	†
1.5KE250CA	A ZEN250V5%CLIPPER	3	500	3.27	500	†
1.5KE27ARL4	A ZENER DIODE T/R	2	1500	.68	1500	†
1.5KE27CA	A ZEN27V5%CLIPPER	2	500	.96	500	†
1.5KE27CARL4	A HIPWR SURMETIC TRANS SUP	2	1500	.96	1500	†
1.5KE30A	A ZEN30V1500W5%C41-11	2	500	.69	500	†
1.5KE30ARL4	A ZENER DIODE T/R	2	1500	.68	1500	†
1.5KE30CA	A ZEN30V5%CLIPPER	3	500	1.92	500	†
1.5KE33A	A ZEN33V1500W5%C41-11	2	500	.69	500	†
1.5KE33ARL4	A ZENER DIODE T/R	2	1500	.78	1500	†
1.5KE33CA	A ZEN33V5%CLIPPER	3	500	1.92	500	†
1.5KE33CARL4	A HIPWR SURMETIC TRANS SUP	2	1500	1.08	1500	†
1.5KE36A	A ZEN36V1500W5%C41-11	2	500	.69	500	†
1.5KE36ARL4	A ZENER DIODE T/R	2	1500	.69	1500	†
1.5KE36CA	A ZEN36V5%CLIPPER	2	500	.96	500	†
1.5KE39A	A ZEN39V1500W5%C41-11	2	500	.69	500	†
1.5KE39ARL4	A ZENER DIODE T/R	2	1500	.69	1500	†
1.5KE39CA	A ZEN39V5%CLIPPER	3	500	1.92	500	†
1.5KE43A	A ZEN43V1500W5%C41-11	2	500	.68	500	†
1.5KE43ARL4	A ZENER DIODE T/R	2	1500	.68	1500	†
1.5KE43CA	A ZEN43V5%CLIPPER	N	500	.96	500	†
1.5KE43CARL4	A HIPWR SURMETIC TRANS SUP	2	1500	.96	1500	†
1.5KE47A	A ZEN47V1500W5%C41-11	3	500	1.36	500	†
1.5KE51A	A ZEN51V1500W5%C41-11	3	500	1.40	500	†
1.5KE56A	A ZEN56V1500W5%C41-11	3	500	1.40	500	†
1.5KE56ARL4	A ZENER DIODE T/R	2	1500	.70	1500	†
1.5KE56CA	A ZEN56V5%CLIPPER	2	500	.96	500	†
1.5KE6.8A	A ZEN6.8V1500W5%C41-11	2	500	.69	500	†
1.5KE6.8ARL4	A ZENER DIODE T/R	2	1500	.69	1500	†
1.5KE6.8CA	A ZEN6.8V5%CLIPPER	2	500	.96	500	†
1.5KE6.8CARL4	A HIPWR SURMETIC TRANS SUP	2	1500	1.08	1500	†
1.5KE62A	A ZEN62V1500W5%C41-11	2	500	.69	500	†
1.5KE62ARL4	A ZENER DIODE T/R	2	1500	.69	1500	†
1.5KE62CA	A ZEN62V5%CLIPPER	N	500	1.09	500	†
1.5KE62CARL4	A ZENER DIODE T/R	2	1500	.96	1500	†
1.5KE68A	A ZEN68V1500W5%C41-11	3	500	1.36	500	†
1.5KE68ARL4	A ZENER DIODE T/R	2	1500	.68	1500	†
1.5KE68CA	A ZEN68V5%CLIPPER	3	500	1.92	500	†
1.5KE7.5A	A ZEN7.5V1500W5%C41-11	3	500	1.36	500	†
1.5KE7.5ARL4	A ZENER DIODE T/R	2	1500	.68	1500	†
1.5KE75ARL4	A ZENER DIODE T/R	2	1500	.68	1500	†
1.5KE75CA	A ZEN75V5%CLIPPER	2	500	.96	500	†
1.5KE8.2A	A ZEN8.2V1500W5%C41-11	2	500	.68	500	†

Type No.	Grp/Description	Per PC	Unit Qty	Sugg. Price	Factory Order	Incrrmnt
1.5KE8.2ARL4	A ZENER DIODE T/R	2	1500	.68	1500	†
1.5KE8.2CA	A ZEN8.2V5%CLIPPER	2	500	.96	500	†
1.5KE82A	A ZEN82V1500W5%C41-11	3	500	1.36	500	†
1.5KE82ARL4	A ZENER DIODE T/R	2	1500	.68	1500	†
1.5KE82CA	A ZEN82V5%CLIPPER	2	500	.96	500	†
1.5KE9.1A	A ZEN9.1V1500W5%C41-11	N	500	.68	500	†
1.5KE9.1ARL4	A ZENER DIODE T/R	2	1500	.68	1500	†
1.5KE9.1CA	A ZEN9.1V1500W5%CLIPPER	N	500	.96	500	†
1.5KE9.1CARL4	A HIPWR SURMETIC TRANS SUP	2	1500	.96	1500	†
1.5KE91A	A ZEN91V1500W5%C41-11	3	500	1.36	500	†
1.5KE91CA	A ZEN91V5%CLIPPER	2	500	.96	500	†
1.5SMC13AT3	A SURFACE MOUNT SUPPRESSOR	2	2500	1.12	2500	†
1.5SMC15AT3	A SURMOUNT XSTR SUPPRESSOR	2	2500	1.12	2500	†
1.5SMC16AT3	A HIGH PWR SURFACE MOUNT	2	2500	1.12	2500	†
1.5SMC20AT3	A SURFACE MOUNT SUPPRESSOR	2	2500	1.12	2500	†
1.5SMC27AT3	A HIGH PWR SURFACE MOUNT	2	2500	1.12	2500	†
1.5SMC36AT3	A SURFACE MOUNT SUPPRESSOR	2	2500	1.12	2500	†
1.5SMC51AT3	A HIGH PWR SURFACE MOUNT	2	2500	1.12	2500	†
1.5SMC6.8AT3	A H/PWR SURMOUNT TRANS SUP	2	2500	1.12	2500	†
1.5SMC7.5AT3	A SURFACE MOUNT SUPPRESSOR	2	2500	1.12	2500	†
1N4001	A REC1A50V STDREC AXIAL	1	1000	.033	1000	†
1N4001RL	A REC1A50V STDREC AXIAL	1	5000	.034	5000	†
1N4002	A REC1A100V STDREC AXIAL	1	1000	.034	1000	†
1N4002RL	A REC1A100V STDREC AXIAL	1	5000	.036	5000	†
1N4003	A REC1A200V STDREC AXIAL	1	1000	.036	1000	†
1N4003RL	A REC1A200V STDREC AXIAL	1	5000	.037	5000	†
1N4004	A REC1A400V STDREC AXIAL	1	1000	.037	1000	†
1N4004RL	A REC1A400V STDREC AXIAL	1	5000	.039	5000	†
1N4005	A REC1A600V STDREC AXIAL	1	1000	.04	1000	†
1N4005RL	A REC1A600V STDREC AXIAL	1	5000	.042	5000	†
1N4006	A REC1A800V STDREC AXIAL	2	1000	.043	1000	†
1N4006RL	A REC1A800V STDREC AXIAL	1	5000	.044	5000	†
1N4007	A REC1A1KV STDREC AXIAL	1	1000	.047	1000	†
1N4007RL	A REC1A1KV STDREC AXIAL	1	5000	.053	5000	†
1N4370ARL	A ZEN2.4V DO35 T/R	2	5000	.17	5000	†
1N4371ARL	A ZEN2.7V0.4W5%D035 T/R	3	5000	.43	5000	†
1N4372A	A ZEN3.0V0.4W5%D035	2	3000	.15	3000	†
1N4372ARL	A ZEN3.0V DO35 T/R	3	5000	.43	5000	†
1N4372D	A LAST ORDER DATE:03/15/98	3	3000	1.60	3000	†
1N4626RL	A ZEN5.6V DO35 T/R	3	5000	2.10	5000	†
1N4678	A ZEN1.8V.25W5%D035	2	3000	.40	3000	†
1N4678RL	A ZEN1.8V DO35 T/R	2	5000	.42	5000	†
1N4679RL	A ZEN2.0V DO35 T/R	2	5000	.84	5000	†
1N4680	A ZEN2.2V.25W5%D035	N	3000	.80	3000	†
1N4680RL	A ZEN2.2V DO35 T/R	3	5000	1.68	5000	†

A = OSPD/Power
 B = Analog/Logic
 J = Transportation
 L = Consumer
 N = Networking
 V = Wireless

S = Proprietary Device
 B = Motorola Blue Chip Program Device
 P = Phoenix Program
 * = First Time in Book
 † \$200 Minimum Waived

N = Key New Motorola Device
 R = Key "Focus" Motorola Device

1 = Mature, Stable, High-Volume Device
 2 = Moderate-Volume Device
 3 = Low-Volume Device

COMMERCIAL COMPONENTS

Type No.	Grp/Description	Per Unit Sugg. Factory			
		Resale Price	Price	Order	
		PC Qty	Price	Incrmnt	
1N4681RL	A ZEN2.4V DO35 T/R	2 5000	.42 5000		†
1N4682	A ZEN2.7V.25W5% D035	2 3000	.40 3000		†
1N4682RL	A ZEN2.7V.25W5% D035	2 5000	.40 5000	S	†
1N4683	A ZEN3.0V.25W5% D035	2 3000	.40 3000		†
1N4684	A ZEN3.3V.25W5% D035	2 3000	.40 3000		†
1N4684RL	A ZEN3.3V DO35 T/R	3 5000	.96 5000		†
1N4685RL	A ZEN3.6V DO35 T/R	2 5000	.84 5000		†
1N4686	A ZEN3.9V.25W5% D035	2 3000	.40 3000		†
1N4686RL	A ZEN3.9V DO35 T/R	2 5000	.42 5000		†
1N4687	A ZEN4.3V.25W5% D035	2 3000	.80 3000		†
1N4687RL	A ZEN4.3V DO35 T/R	3 5000	.64 5000		†
1N4688	A ZEN4.7V.25W5% D035	2 3000	.40 3000		†
1N4688RL	A ZEN4.7V DO35 T/R	2 5000	.42 5000		†
1N4689	A ZEN5.1V.25W5% D035	2 3000	.26 3000		†
1N4689RL	A ZEN5.1V DO35 T/R	2 5000	.28 5000		†
1N4690	A ZEN5.6V.25W5% D035	2 3000	.40 3000		†
1N4690RL	A ZEN5.6V DO35 T/R	2 5000	.42 5000		†
1N4691	A ZEN6.2V.25W5% D035	2 3000	.40 3000		†
1N4691RL	A ZEN6.2V DO35 T/R	2 5000	.42 5000		†
1N4692	A ZEN6.8V.25W5% D035	2 3000	.80 3000		†
1N4692RL	A ZEN6.8V.25W5% D035	2 5000	.80 5000	S	†
1N4693	A ZEN7.5V.25W5% D035	2 3000	.80 3000		†
1N4693RL	A ZEN7.5V DO35 T/R	3 5000	1.68 5000		†
1N4694RL	A ZEN8.2V DO35 T/R	3 5000	.96 5000		†
1N4695	A ZEN8.7V.25W5% D035	3 3000	1.60 3000		†
1N4696RL	A ZEN9.1V DO35 T/R	3 5000	.96 5000		†
1N4697	A ZEN10V.25W5% D035	2 3000	.40 3000		†
1N4697RL	A ZEN10V.25W5% D035	2 5000	.84 5000		†
1N4698	A ZEN11V.25W5% D035	3 3000	1.60 3000		†
1N4699	A ZEN12V.25W5% D035	2 3000	.80 3000		†
1N4699RL	A ZEN12V DO35 T/R	3 5000	1.68 5000		†
1N4700	A ZEN13V.25W5% D035	3 3000	1.60 3000		†
1N4701	A ZEN13V.25W5% D035	3 3000	1.60 3000		†
1N4701CRL	A LAST ORDER DATE:03/15/98	2 5000	.82 5000		†
1N4701RL	A ZEN14V.25W5% D035	2 5000	.30 5000	S	†
1N4702	A ZEN15V.25W5% D035	2 3000	.80 3000		†
1N4703RL	A ZEN13V.25W5% D035	2 5000	.80 5000	S	†
1N4704RL	A ZEN17V.25W5% D035	2 5000	.54 5000	S	†
1N4705	A ZEN18V.25W5% D035	3 3000	1.60 3000		†
1N4705RL	A ZEN18V.25W5% D035	2 5000	.34 5000	S	†
1N4708RL	A ZEN22V.25W5% D035	2 5000	.51 5000	S	†
1N4728A	A ZEN3.3V1W5% DO41	2 2000	.098 2000		†
1N4728ARL	A ZEN3.3V DO41 T/R	2 6000	.12 6000		†
1N4729A	A ZEN3.6V1W5% DO41	N 2000	.098 2000	S	†
1N4729ARL	A ZEN3.6V1W5% DO41	2 6000	.11 6000	S	†

Type No.	Grp/Description	Per Unit Sugg. Factory			
		Resale Price	Price	Order	
		PC Qty	Price	Incrmnt	
1N4730A	A ZEN3.9V1W5% DO41	2 2000	.098 2000		†
1N4730ARL	A ZEN3.9V DO41 T/R	2 6000	.12 6000		†
1N4731A	A ZEN4.3V1W5% DO41	2 2000	.098 2000		†
1N4731ARL	A ZEN4.3V DO41 T/R	2 6000	.12 6000		†
1N4732A	A ZEN4.7V1W5% DO41	2 2000	.098 2000		†
1N4732ARL	A ZEN4.7V DO41 T/R	2 6000	.12 6000		†
1N4733A	A ZEN5.1V1W5% DO41	1 2000	.10 2000		†
1N4733ARL	A ZEN5.1V DO41 T/R	1 6000	.11 6000		†
1N4734A	A ZEN5.6V1W5% DO41	1 2000	.098 2000		†
1N4734ARL	A ZEN5.6V DO41 T/R	1 6000	.12 6000		†
1N4735A	A ZEN6.2V1W5% DO41	1 2000	.09 2000		†
1N4735ARL	A ZEN6.2V DO41 T/R	1 6000	.10 6000		†
1N4736A	A ZEN6.8V1W5% DO41	2 2000	.10 2000		†
1N4736ARL	A ZEN6.8V DO41 T/R	1 6000	.11 6000		†
1N4737A	A ZEN7.5V1W5% DO41	2 2000	.098 2000		†
1N4737ARL	A ZEN7.5V DO41 T/R	2 6000	.12 6000		†
1N4738A	A ZEN8.2V1W5% DO41	2 2000	.098 2000		†
1N4738ARL	A ZEN8.2V DO41 T/R	2 6000	.12 6000		†
1N4739A	A ZEN9.1V1W5% DO41	2 2000	.098 2000		†
1N4739ARL	A ZEN9.1V DO41 T/R	2 6000	.12 6000		†
1N4740A	A ZEN10V1W5% DO41	2 2000	.096 2000		†
1N4740ARL	A ZEN10V DO41 T/R	1 6000	.11 6000		†
1N4741ARL	A ZEN11V DO41 T/R	2 6000	.12 6000		†
1N4742A	A ZEN12V1W5% DO41	1 2000	.094 2000		†
1N4742ARL	A ZEN12V DO41 T/R	1 6000	.10 6000		†
1N4743A	A ZEN13V1W5% DO41	2 2000	.098 2000		†
1N4743ARL	A ZEN13V DO41 T/R	2 6000	.12 6000		†
1N4744A	A ZEN15V1W5% DO41	1 2000	.10 2000		†
1N4744ARL	A ZEN15V DO41 T/R	1 6000	.11 6000		†
1N4745A	A ZEN16V1W5% DO41	2 2000	.098 2000		†
1N4745ARL	A ZEN16V DO41 T/R	1 6000	.12 6000		†
1N4746A	A ZEN18V1W5% DO41	2 2000	.20 2000		†
1N4746ARL	A ZEN18V DO41 T/R	1 6000	.12 6000		†
1N4747A	A ZEN20V1W5% DO41	2 2000	.098 2000		†
1N4747ARL	A ZEN20V DO41 T/R	1 6000	.12 6000		†
1N4748A	A ZEN22V1W5% DO41	2 2000	.098 2000		†
1N4748ARL	A ZEN22V DO41 T/R	2 6000	.12 6000		†
1N4749A	A ZEN24V1W5% DO41	2 2000	.098 2000		†
1N4749ARL	A ZEN24V DO41 T/R	1 6000	.12 6000		†
1N4750A	A ZEN27V1W5% DO41	2 2000	.098 2000		†
1N4750ARL	A ZEN27V DO41 T/R	2 6000	.088 6000		†
1N4751A	A ZEN30V1W5% DO41	2 2000	.098 2000		†
1N4751ARL	A ZEN30V DO41 T/R	2 6000	.12 6000		†
1N4752A	A ZEN33V1W5% DO41	2 2000	.098 2000		†
1N4752ARL	A ZEN33V DO41 T/R	2 6000	.12 6000		†

A = OSPD/Power
 B = Analog/Logic
 J = Transportation
 L = Consumer
 N = Networking
 V = Wireless

S = Proprietary Device
 B = Motorola Blue Chip Program Device
 P = Phoenix Program
 * = First Time in Book
 † \$200 Minimum Waived

N = Key New Motorola Device
 R = Key "Focus" Motorola Device

1 = Mature, Stable, High-Volume Device
 2 = Moderate-Volume Device
 3 = Low-Volume Device

EFFECTIVE DATE: JANUARY 10, 1998

COMMERCIAL COMPONENTS

Type No.	Grp/Description	Per Unit Sugg. Factory						Type No.	Grp/Description	Per Unit Sugg. Factory					
		PC	Qty	Price						Order	PC	Qty			
1N4753ARL	A ZEN36V DO41 T/R	2	6000	.18	6000	†	1N5227BRL	A ZEN3.6V DO35 T/R	2	5000	.086	5000	†		
1N4754A	A ZEN39V1W5% D041	2	2000	.16	2000	†	1N5228B	A ZEN3.9V0.5W5% D035	2	3000	.076	3000	†		
1N4754ARL	A ZEN39V DO41 T/R	2	6000	.18	6000	†	1N5228BRL	A ZEN3.9V DO35 T/R	2	5000	.086	5000	†		
1N4755ARL	A ZEN43V1W5% D041	2	6000	.13	6000	S †	1N5229B	A ZEN4.3V0.5W5% D035	2	3000	.076	3000	†		
1N4756A	A ZEN47V1W5% D041	N	2000	.12	2000	†	1N5229BRL	A ZEN4.3V DO35 T/R	2	5000	.086	5000	†		
1N4756ARL	A ZEN47V1W5% D041	2	6000	.13	6000	S †	1N5230B	A ZEN4.7V0.5W5% D035	2	3000	.076	3000	†		
1N4757ARL	A ZEN51V DO41 T/R	2	6000	.38	6000	†	1N5230BRL	A ZEN4.7V DO35 T/R	1	5000	.086	5000	†		
1N4758ARL	A ZEN56V1W5% D041	2	6000	.24	6000	S †	1N5230BS	A ZEN4.7V0.5W5% D035	N	3000	.05	3000 *	†		
1N4759A	A ZEN62V1W5% D041	2	2000	.32	2000	†	1N5230BSRL	A ZEN4.7V DO35 T/R	N	5000	.05	5000 *	†		
1N4759ARL	A ZEN62V DO41 T/R	2	6000	.34	6000	†	1N5230C	A LAST ORDER DATE:03/15/98	3	3000	.55	3000	†		
1N4760A	A ZEN68V1W5% D041	2	2000	.32	2000	†	1N5230CRL	A ZEN4.7V0.5W2% D035 T/R	3	5000	.59	5000	†		
1N4760ARL	A ZEN68V DO41 T/R	2	6000	.34	6000	†	1N5231B	A ZEN5.1V0.5W5% D035	1	3000	.07	3000	†		
1N4761A	A ZEN75V1W5% D041	2	2000	.32	2000	†	1N5231BRL	A ZEN5.1V DO35 T/R	1	5000	.086	5000	†		
1N4761ARL	A ZEN75V DO41 T/R	2	6000	.34	6000	†	1N5231BS	A ZEN5.1V0.5W5% D035	N	1	.05	1 *	†		
1N4762ARL	A ZEN82V1W5% D041	2	6000	.24	6000	S †	1N5231BSRL	A ZEN5.1V DO35 T/R	N	5000	.05	5000 *	†		
1N4763ARL	A ZEN91V1W5% D041	2	6000	.24	6000	S †	1N5231C	A LAST ORDER DATE:03/15/98	3	3000	.55	3000	†		
1N4764A	A ZEN100V1W5% D041	2	2000	.38	2000	†	1N5231DRL	A ZEN5.1V0.5W1% D035 T/R	3	5000	1.64	5000	†		
1N4764ARL	A ZEN100V DO41 T/R	2	6000	.40	6000	†	1N5232B	A ZEN5.6V0.5W5% D035	2	3000	.076	3000	†		
1N4933	A REC1A50V FASTREC AXIAL	2	1000	.057	1000	†	1N5232BRL	A ZEN5.6V DO35 T/R	1	5000	.086	5000	†		
1N4933RL	A REC1A50V FASTREC AXIAL	2	5000	.057	5000	†	1N5232BS	A ZEN5.6V0.5W5% D035	N	3000	.05	3000 *	†		
1N4934	A REC1A100V FASTREC AXIAL	2	1000	.072	1000	†	1N5232BSRL	A ZEN5.6V DO35 T/R	N	5000	.05	5000 *	†		
1N4934RL	A REC1A100V FASTREC AXIAL	2	5000	.072	5000	†	1N5232D	A LAST ORDER DATE:03/15/98	3	3000	1.60	3000	†		
1N4935	A REC1A200V FASTRC AXIAL	1	1000	.086	1000	†	1N5233B	A ZEN6.0V0.5W5% D035	2	3000	.076	3000	†		
1N4935RL	A REC1A200V FASTREC AXIAL	1	5000	.086	5000	†	1N5233BRL	A ZEN6.0V DO35 T/R	2	5000	.086	5000	†		
1N4936	A REC1A400V FASTRC AXIAL	1	1000	.10	1000	†	1N5234B	A ZEN6.2V0.5W5% D035	2	3000	.076	3000	†		
1N4936RL	A REC1A400V FASTRC AXIAL	1	5000	.10	5000	†	1N5234BRL	A ZEN6.2V DO35 T/R	2	5000	.086	5000	†		
1N4937	A REC1A600V FASTRC AXIAL	1	1000	.11	1000	†	1N5234BS	A ZEN6.2V0.5W5% D035	N	3000	.05	3000 *	†		
1N4937RL	A REC1A600V FASTRC AXIAL	1	5000	.12	5000	†	1N5234BSRL	A ZEN6.2V DO35 T/R	N	5000	.05	5000 *	†		
1N5139	A LAST ORDER DATE:09/20/98	3	200	6.67	200	†	1N5235B	A ZEN6.8V0.5W5% D035	2	3000	.076	3000	†		
1N5139A	A LAST ORDER DATE:09/20/98	3	200	10.00	200	†	1N5235BRL	A ZEN6.8V DO35 T/R	2	5000	.086	5000	†		
1N5140	A LAST ORDER DATE:09/20/98	3	200	6.67	200	†	1N5235BS	A ZEN6.8V0.5W5% D035	N	3000	.05	3000 *	†		
1N5140A	A LAST ORDER DATE:09/20/98	3	200	10.00	200	†	1N5235BSRL	A ZEN6.8V DO35 T/R	N	5000	.05	5000 *	†		
1N5144	A LAST ORDER DATE:09/20/98	3	200	6.67	200	†	1N5235C	A LAST ORDER DATE:03/15/98	3	3000	.55	3000	†		
1N5144A	A LAST ORDER DATE:09/20/98	2	200	6.60	200	†	1N5235D	A LAST ORDER DATE:03/15/98	3	3000	1.60	3000	†		
1N5146A	A LAST ORDER DATE:09/20/98	3	200	10.00	200	†	1N5236B	A ZEN7.5V0.5W5% D035	2	3000	.076	3000	†		
1N5148	A LAST ORDER DATE:09/20/98	3	200	6.67	200	†	1N5236BRL	A ZEN7.5V DO35 T/R	2	5000	.086	5000	†		
1N5148A	A LAST ORDER DATE:09/20/98	3	200	10.00	200	†	1N5236CRL	A ZEN7.5V0.5W2% D035 T/R	3	5000	.59	5000	†		
1N5221B	A ZEN2.4V0.5W5% D035	2	3000	.24	3000	†	1N5237B	A ZEN8.2V0.5W5% D035	2	3000	.076	3000	†		
1N5221BRL	A ZEN2.4V DO35 T/R	2	5000	.12	5000	†	1N5237BRL	A ZEN8.2V DO35 T/R	2	5000	.086	5000	†		
1N5223B	A ZEN2.7V0.5W5% D035	2	3000	.24	3000	†	1N5237C	A ZEN8.2V0.5W2% D035	3	3000	.55	3000	†		
1N5223BRL	A ZEN2.7V DO35 T/R	2	5000	.26	5000	†	1N5238B	A ZEN8.7V0.5W5% D035	3	3000	.38	3000	†		
1N5225B	A ZEN3.0V0.5W5% D035	2	3000	.15	3000	†	1N5238BRL	A ZEN8.7V DO35 T/R	3	5000	.22	5000	†		
1N5225BRL	A ZEN3.0V DO35 T/R	2	5000	.26	5000	†	1N5239B	A ZEN9.1V0.5W5% D035	2	3000	.076	3000	†		
1N5226B	A ZEN3.3V0.5W5% D035	2	3000	.076	3000	†	1N5239BRL	A ZEN9.1V DO35 T/R	2	5000	.086	5000	†		
1N5226BRL	A ZEN3.3V DO35 T/R	2	5000	.086	5000	†	1N5239D	A ZEN9.1V0.5W1% D035	3	3000	1.60	3000	†		

A = OSPD/Power
 B = Analog/Logic
 J = Transportation
 L = Consumer
 N = Networking
 V = Wireless

S = Proprietary Device
 B = Motorola Blue Chip Program Device
 P = Phoenix Program
 * = First Time in Book
 † \$200 Minimum Waived

N = Key New Motorola Device
 R = Key "Focus" Motorola Device

1 = Mature, Stable, High-Volume Device
 2 = Moderate-Volume Device
 3 = Low-Volume Device

EFFECTIVE DATE: JANUARY 10, 1998

COMMERCIAL COMPONENTS

Type No.	Grp/Description	Per PC	Unit Qty	Sugg. Resale Price	Factory Order Incrmnt	
1N5240B	A ZEN10V0.5W5%D035	2	3000	.072	3000	†
1N5240BRL	A ZEN10V DO35 T/R	1	5000	.078	5000	†
1N5240C	A LASTORDERDATE:03/15/98	3	3000	.55	3000	†
1N5241BRL	A ZEN11V DO35 T/R	2	5000	.086	5000	†
1N5242B	A ZEN12V0.5W5%D035	2	3000	.07	3000	†
1N5242BRL	A ZEN12V DO35 T/R	1	5000	.07	5000	†
1N5243BRL	A ZEN13V DO35 T/R	2	5000	.086	5000	†
1N5244BRL	A ZEN14V DO35 T/R	2	5000	.086	5000	†
1N5244D	A LASTORDERDATE:03/15/98	3	3000	1.60	3000	†
1N5245B	A ZEN15V0.5W5%D035	2	3000	.076	3000	†
1N5245BRL	A ZEN15V DO35 T/R	1	5000	.086	5000	†
1N5246BRL	A ZEN16V DO35 T/R	2	5000	.086	5000	†
1N5247BRL	A ZEN17V DO35 T/R	2	5000	.086	5000	†
1N5248B	A ZEN18V0.5W5%D035	2	3000	.076	3000	†
1N5248BRL	A ZEN18V0.5W5%D035	2	5000	.086	5000	†
1N5250BRL	A ZEN20V DO35 T/R	2	5000	.086	5000	†
1N5251BRL	A ZEN22V DO35 T/R	2	5000	.086	5000	†
1N5252BRL	A ZEN24V DO35 T/R	2	5000	.086	5000	†
1N5253B	A ZEN25V0.5W5%D035	3	3000	.18	3000	†
1N5253BRL	A ZEN25V0.5W5%D035	3	5000	.22	5000	†
1N5254B	A ZEN27V0.5W5%D035	2	3000	.076	3000	†
1N5254BRL	A ZEN27V DO35 T/R	3	5000	.22	5000	†
1N5255BRL	A ZEN28V DO35 T/R	2	5000	.086	5000	†
1N5256BRL	A ZEN30V DO35 T/R	2	5000	.086	5000	†
1N5257BRL	A ZEN33V DO35 T/R	2	5000	.086	5000	†
1N5258BRL	A ZEN36V DO35 T/R	2	5000	.13	5000	†
1N5259BRL	A ZEN39V DO35 T/R	3	5000	.32	5000	†
1N5260BRL	A ZEN43V DO35 T/R	2	5000	.13	5000	†
1N5261BRL	A ZEN47V DO35 T/R	3	5000	.32	5000	†
1N5262BRL	A ZEN51V DO35 T/R	2	5000	.52	5000	†
1N5263BRL	A ZEN56V0.5W5%D035	2	5000	.16	5000	S †
1N5264BRL	A ZEN60V0.5W5%D035	2	5000	.40	5000	S †
1N5265BRL	A ZEN62V0.5W5%D035	2	5000	.78	5000	†
1N5266BRL	A ZEN68V0.5W5%D035	2	5000	.17	5000	S †
1N5267BRL	A ZEN75V DO35 T/R	3	5000	1.04	5000	†
1N5268B	A ZEN82V0.5W5%D035	3	3000	1.09	3000	†
1N5268BRL	A ZEN82V DO35 T/R	3	5000	1.04	5000	†
1N5270BRL	A ZEN91V DO35 T/R	3	5000	.59	5000	†
1N5271B	A ZEN100V0.5W5%D035	2	3000	.34	3000	†
1N5271BRL	A ZEN100V DO35 T/R	2	5000	.36	5000	†
1N5272B	A ZEN110V0.5W5%D035	3	3000	1.36	3000	†
1N5272BRL	A ZEN110V DO35 T/R	3	5000	.82	5000	†
1N5273BRL	A ZEN120V DO35 T/R	2	5000	.36	5000	†
1N5274B	A ZEN130V0.5W5%D035	2	3000	.68	3000	†
1N5274BRL	A ZEN130V DO35 T/R	3	5000	1.56	5000	†

Type No.	Grp/Description	Per PC	Unit Qty	Sugg. Resale Price	Factory Order Incrmnt	
1N5275BRL	A ZEN140V DO35 T/R	3	5000	1.56	5000	†
1N5276B	A ZEN150V0.5W5%D035	2	3000	.68	3000	†
1N5276BRL	A ZEN150V DO35 T/R	2	5000	.36	5000	†
1N5278BRL	A ZEN170V DO35 T/R	3	5000	1.56	5000	†
1N5279B	A ZEN180V0.5W5%D035	2	3000	.68	3000	†
1N5279BRL	A ZEN180V DO35 T/R	3	5000	1.44	5000	†
1N5281B	A ZEN200V0.5W5%D035	2	3000	.34	3000	†
1N5281BRL	A ZEN200V DO35 T/R	2	5000	.78	5000	†
1N5283	A ZEN1.0V0.6W.22MAD07	2	200	7.50	200	†
1N5287	A ZEN1.0V0.6W.33MAD07	2	200	5.30	200	†
1N5298	A ZEN1.4V0.6W1.1MAD07	2	200	5.30	200	†
1N5305	A ZEN1.85V0.6W2.0MAD07	2	200	7.50	200	†
1N5309	A ZEN2.25V0.6W3.0MAD07	2	200	5.30	200	†
1N5311	A ZEN2.5V0.6W3.6MAD07	2	200	10.60	200	†
1N5314	A ZEN2.9V0.6W4.7MAD07	1	200	6.30	200	†
1N5333B	A ZEN3.3V5W5%CASE17	2	1000	.61	1000	†
1N5333BRL	A ZEN3.3V CASE17 T/R	2	4000	.61	4000	†
1N5334BRL	A ZEN3.6V5W5%CASE17	2	4000	.64	4000	S †
1N5335B	A ZEN3.9V5W5%CASE17	2	1000	1.32	1000	†
1N5335BRL	A ZEN3.9V CASE17 T/R	3	4000	2.35	4000	†
1N5336B	A ZEN4.3V5W5%CASE17	2	1000	1.32	1000	†
1N5336BRL	A ZEN4.3V CASE17 T/R	3	4000	2.35	4000	†
1N5337B	A ZEN4.7V5W5%CASE17	2	1000	.66	1000	†
1N5337BRL	A ZEN4.7V CASE17 T/R	2	4000	.68	4000	†
1N5338B	A ZEN5.1V5W5%CASE17	2	1000	.66	1000	†
1N5338BRL	A ZEN5.1V CASE17 T/R	1	4000	.68	4000	†
1N5339B	A ZEN5.6V5W5%CASE17	1	1000	.46	1000	†
1N5339BRL	A ZEN5.6V CASE17 T/R	1	4000	.48	4000	†
1N5340B	A ZEN6.0V5W5%CASE17	2	1000	.66	1000	†
1N5340BRL	A ZEN6.0V CASE17 T/R	2	4000	.68	4000	†
1N5341B	A ZEN6.2V5W5%CASE17	2	1000	.66	1000	†
1N5341BRL	A ZEN6.2V CASE17 T/R	1	4000	.68	4000	†
1N5342B	A ZEN6.8V5W5%CASE17	2	1000	.66	1000	†
1N5342BRL	A ZEN6.8V CASE17 T/R	2	4000	.68	4000	†
1N5343B	A ZEN7.5V5W5%CASE17	2	1000	.66	1000	†
1N5343BRL	A ZEN7.5V CASE17 T/R	2	4000	.68	4000	†
1N5344B	A ZEN8.2V5W5%CASE17	2	1000	.66	1000	†
1N5344BRL	A ZEN8.2V CASE17 T/R	2	4000	.68	4000	†
1N5345BRL	A ZEN8.7V5W5%CASE17	2	4000	.68	4000	S †
1N5346B	A ZEN9.1V5W5%CASE17	2	1000	.66	1000	†
1N5346BRL	A ZEN9.1V CASE17 T/R	2	4000	.68	4000	†
1N5347B	A ZEN10V5W5%CASE17	2	1000	.66	1000	†
1N5347BRL	A ZEN10V CASE17 T/R	2	4000	.68	4000	†
1N5348B	A ZEN11V5W5%CASE17	2	1000	.66	1000	†
1N5348BRL	A ZEN11V CASE17 T/R	3	4000	1.36	4000	†

A = OSPD/Power
 B = Analog/Logic
 J = Transportation
 L = Consumer
 N = Networking
 V = Wireless

S = Proprietary Device
 B = Motorola Blue Chip Program Device
 P = Phoenix Program
 ★ = First Time in Book
 † \$200 Minimum Waived

N = Key New Motorola Device
 R = Key "Focus" Motorola Device

1 = Mature, Stable, High-Volume Device
 2 = Moderate-Volume Device
 3 = Low-Volume Device

COMMERCIAL COMPONENTS

Type No.	Grp/Description	Per Unit Sugg. Factory			†	Type No.	Grp/Description	Per Unit Sugg. Factory			†		
		PC	Qty	Price				Order	PC	Qty		Price	Order
1N5349B	A ZEN12V5W5%CASE17	1	1000	.52	1000	†	1N5372B	A ZEN62V5W5%CASE17	2	1000	.66	1000	†
1N5349BRL	A ZEN12V CASE17 T/R	1	4000	.54	4000	†	1N5372BRL	A ZEN62V CASE17 T/R	3	4000	1.36	4000	†
1N5350B	A ZEN13V5W5%CASE17	2	1000	.66	1000	†	1N5373B	A ZEN68V5W5%CASE17	N	1000	.66	1000	†
1N5350BRL	A ZEN13V CASE17 T/R	2	4000	.68	4000	†	1N5373BRL	A ZEN68V CASE17 T/R	2	4000	.68	4000	†
1N5351B	A ZEN14V5W5%CASE17	2	1000	1.32	1000	†	1N5374B	A ZEN75V5W5%CASE17	2	1000	.66	1000	†
1N5351BRL	A ZEN14V CASE17 T/R	2	4000	.68	4000	†	1N5374BRL	A ZEN75V CASE17 T/R	3	4000	1.36	4000	†
1N5352B	A ZEN15V5W5%CASE17	1	1000	.66	1000	†	1N5375B	A ZEN82V5W5%CASE17	2	1000	.66	1000	†
1N5352BRL	A ZEN15V CASE17 T/R	1	4000	.68	4000	†	1N5375BRL	A ZEN82V CASE17 T/R	2	4000	.68	4000	†
1N5353B	A ZEN16V5W5%CASE17	2	1000	.66	1000	†	1N5376B	A ZEN87V5W5%CASE17	N	1000	.62	1000	S †
1N5353BRL	A ZEN16V CASE17 T/R	2	4000	.68	4000	†	1N5376BRL	A ZEN DIODE	2	1000	.64	1000	†
1N5354B	A ZEN17V5W5%CASE17	2	1000	1.32	1000	†	1N5377B	A ZEN91V5W5%CASE17	2	1000	1.32	1000	†
1N5354BRL	A ZEN17V CASE17 T/R	3	4000	2.35	4000	†	1N5377BRL	A ZEN91V CASE17 T/R	3	4000	2.35	4000	†
1N5355B	A ZEN18V5W5%CASE17	2	1000	.66	1000	†	1N5378B	A ZEN100V5W5%CASE17	2	1000	.66	1000	†
1N5355BRL	A ZEN18V CASE17 T/R	1	4000	.68	4000	†	1N5378BRL	A ZEN100V CASE17 T/R	2	4000	.68	4000	†
1N5356B	A ZEN19V5W5%CASE17	3	1000	2.28	1000	†	1N5379B	A ZEN110V5W5%CASE17	N	1000	1.00	1000	S †
1N5356BRL	A ZEN19V CASE17 T/R	3	4000	1.36	4000	†	1N5379BRL	A ZEN110V5W5%CASE17	2	4000	1.02	4000	S †
1N5357B	A ZEN20V5W5%CASE17	2	1000	.66	1000	†	1N5380B	A ZEN120V5W5%CASE17	2	1000	.66	1000	†
1N5357BRL	A ZEN20V CASE17 T/R	2	4000	.68	4000	†	1N5380BRL	A ZEN120V CASE17 T/R	3	4000	1.36	4000	†
1N5358B	A ZEN22V5W5%CASE17	2	1000	.66	1000	†	1N5381BRL	A ZEN130V5W5%CASE17	2	4000	.64	4000	S †
1N5358BRL	A ZEN22V CASE17 T/R	2	4000	.68	4000	†	1N5382B	A ZEN140V5W5%CASE17	N	1000	.62	1000	S †
1N5359B	A ZEN24V5W5%CASE17	2	1000	.66	1000	†	1N5382BRL	A ZEN140V5W5%CASE17	2	4000	.64	4000	S †
1N5359BRL	A ZEN24V CASE17 T/R	1	4000	.68	4000	†	1N5383B	A ZEN150V5W5%CASE17	2	1000	.66	1000	†
1N5360B	A ZEN25V5W5%CASE17	2	1000	1.32	1000	†	1N5383BRL	A ZEN150V CASE17 T/R	2	4000	.68	4000	†
1N5360BRL	A ZEN25V CASE17 T/R	3	4000	2.35	4000	†	1N5384BRL	A ZEN160V5W5%CASE17	2	4000	.64	4000	S †
1N5361BRL	A ZEN27V CASE17 T/R	2	4000	.68	4000	†	1N5385B	A ZEN170V5W5%CASE17	N	1000	.62	1000	†
1N5362B	A ZEN28V5W5%CASE17	2	1000	1.32	1000	†	1N5385BRL	A ZEN DIODE	2	1000	.64	1000	†
1N5362BRL	A ZEN28V CASE17 T/R	2	4000	1.36	4000	†	1N5386B	A ZEN180V5W5%CASE17	2	1000	1.32	1000	†
1N5363B	A ZEN30V5W5%CASE17	2	1000	.66	1000	†	1N5386BRL	A ZEN180V5W5%CASE17	2	4000	1.36	4000	†
1N5363BRL	A ZEN30V CASE17 T/R	2	4000	.68	4000	†	1N5387B	A ZEN190V5W5%CASE17	N	1000	.62	1000	S †
1N5364B	A ZEN33V5W5%CASE17	2	1000	.66	1000	†	1N5387BRL	A ZEN190V5W5%CASE17	2	4000	.64	4000	S †
1N5364BRL	A ZEN33V CASE17 T/R	1	4000	.68	4000	†	1N5388B	A ZEN200V5W5%CASE17	2	1000	.66	1000	†
1N5365B	A ZEN36V5W5%CASE17	2	1000	.66	1000	†	1N5388BRL	A ZEN200V CASE17 T/R	2	4000	.68	4000	†
1N5365BRL	A ZEN36V CASE17 T/R	2	4000	.68	4000	†	1N5400	A REC3A50V STDREC AXIAL	1	500	.086	500	†
1N5366B	A ZEN39V5W5%CASE17	2	1000	.66	1000	†	1N5400RL	A REC3A50V STDREC AXIAL	2	1200	.086	1200	†
1N5366BRL	A ZEN39V CASE17 T/R	2	4000	.68	4000	†	1N5401	A REC3A100V STDREC AXIAL	1	500	.086	500	†
1N5367B	A ZEN43V5W5%CASE17	2	1000	.66	1000	†	1N5401RL	A REC3A100V STDREC AXIAL	1	1200	.086	1200	†
1N5367BRL	A ZEN43V CASE17 T/R	2	4000	.68	4000	†	1N5402	A REC3A200V STDREC AXIAL	1	500	.086	500	†
1N5368B	A ZEN47V5W5%CASE17	2	1000	.66	1000	†	1N5402RL	A REC3A200V STDREC AXIAL	1	1200	.093	1200	†
1N5368BRL	A ZEN47V CASE17 T/R	3	4000	1.36	4000	†	1N5404	A REC3A400V STDREC AXIAL	1	500	.10	500	†
1N5369B	A ZEN51V5W5%CASE17	2	1000	1.32	1000	†	1N5404RL	A REC3A400V STDREC AXIAL	1	1200	.11	1200	†
1N5369BRL	A ZEN51V CASE17 T/R	2	4000	1.36	4000	†	1N5406	A REC3A600V STDREC AXIAL	2	500	.11	500	†
1N5370B	A ZEN56V5W5%CASE17	2	1000	.66	1000	†	1N5406RL	A REC3A600V STDREC AXIAL	1	1200	.12	1200	†
1N5370BRL	A ZEN56V CASE17 T/R	2	4000	.68	4000	†	1N5407	A REC3A800V STDREC AXIAL	2	500	.13	500	†
1N5371B	A ZEN60V5W5%CASE17	2	1000	1.32	1000	†	1N5407RL	A REC3A800V STDREC AXIAL	3	1200	.48	1200	†
1N5371BRL	A ZEN60V CASE17 T/R	3	4000	2.35	4000	†	1N5408	A REC3A1KV STDREC AXIAL	2	500	.16	500	†

A = OSPD/Power
 B = Analog/Logic
 J = Transportation
 L = Consumer
 N = Networking
 V = Wireless

S = Proprietary Device
 B = Motorola Blue Chip Program Device
 P = Phoenix Program
 ★ = First Time in Book
 † \$200 Minimum Waived

N = Key New Motorola Device
 R = Key "Focus" Motorola Device

1 = Mature, Stable, High-Volume Device
 2 = Moderate-Volume Device
 3 = Low-Volume Device

EFFECTIVE DATE: JANUARY 10, 1998

COMMERCIAL COMPONENTS

Type No.	Grp/Description	Per Unit Sugg.		Factory Order	Incrmnt	
		Resale Price	Price			
1N5408RL	A REC3A1KV STDRECAIAL	2	1200	.15	1200	†
1N5444A	A LAST ORDER DATE:09/20/98	3	200	6.65	200	†
1N5444B	A LAST ORDER DATE:09/20/98	2	200	6.60	200	†
1N5445A	A LAST ORDER DATE:09/20/98	3	200	6.67	200	†
1N5446B	A LAST ORDER DATE:09/20/98	3	200	10.00	200	†
1N5448B	A LAST ORDER DATE:09/20/98	3	200	10.00	200	†
1N5450A	A SS GEN PURTUN DIODE D07	3	200	6.65	200	†
1N5451A	A LAST ORDER DATE:09/20/98	3	200	7.04	200	†
1N5455A	A LAST ORDER DATE:09/20/98	3	200	6.65	200	†
1N5456A	A LAST ORDER DATE:09/20/98	3	200	6.67	200	†
1N5456B	A LAST ORDER DATE:09/20/98	3	200	10.00	200	†
1N5817	A REC1A20V SCHOTT AXIAL	1	1000	.17	1000	†
1N5817RL	A REC1A20V SCHOTT AXIAL	1	5000	.17	5000	†
1N5818	A REC1A30V SCHOTT AXIAL	1	1000	.19	1000	†
1N5818RL	A REC1A30V SCHOTT AXIAL	1	5000	.19	5000	†
1N5819	A REC1A40V SCHOTT AXIAL	1	1000	.20	1000	†
1N5819RL	A REC1A40V SCHOTT AXIAL	1	5000	.20	5000	†
1N5820	A REC3A20V SCHOTT AXIAL	1	500	.33	500	†
1N5820RL	A REC3A20V SCHOTT AXIAL	1	1500	.30	1500	†
1N5821	A REC3A30V SCHOTT AXIAL	1	500	.33	500	†
1N5821RL	A REC3A30V SCHOTT AXIAL	1	1500	.30	1500	†
1N5822	A REC3A40V SCHOTT AXIAL	1	500	.33	500	†
1N5822RL	A REC3A40V SCHOTT AXIAL	1	1500	.30	1500	†
1N5908	A ZEN6.2V1500W5% C41-11	1	500	.69	500	†
1N5908RL4	A ZEN6.2V1500W5% T/R	1	1500	.80	1500	†
1N5913B	A ZEN3.3V1.5W5% D041	3	2000	1.68	2000	†
1N5914B	A ZEN3.6V1.5W5% D041	3	2000	1.68	2000	†
1N5915BRL	A LAST ORDER DATE:06/06/98	2	6000	.40	6000	†
1N5916B	A LAST ORDER DATE:06/06/98	3	2000	1.68	2000	†
1N5916BRL	A LAST ORDER DATE:06/06/98	2	6000	.40	6000	†
1N5917B	A ZEN4.7V1.5W5% D041	3	2000	1.68	2000	†
1N5918B	A ZEN5.1V1.5W5% D041	3	2000	1.68	2000	†
1N5918BRL	A ZEN5.1V DO41 T/R	3	6000	1.00	6000	†
1N5919B	A ZEN5.6V1.5W5% D041	3	2000	1.68	2000	†
1N5919BRL	A ZEN DIODE	2	6000	.40	6000	†
1N5920B	A ZEN6.2V1.5W5% D041	3	2000	.96	2000	†
1N5920BRL	A ZEN DIODE	2	6000	.39	6000	†
1N5921B	A ZEN6.8V1.5W5% D041	3	2000	1.68	2000	†
1N5921BRL	A ZEN DIODE	2	6000	.39	6000	†
1N5923B	A ZEN DIODE	3	2000	1.92	2000	†
1N5923BRL	A REEL PK FOR1N5923B	2	6000	.40	6000	†
1N5924B	A ZEN9.1V1.5W5% D041	3	2000	.96	2000	†
1N5924BRL	A ZEN DIODE	2	6000	.39	6000	†
1N5925B	A ZEN10V1.5W5% D041	3	2000	1.68	2000	†
1N5926B	A ZEN11V1.5W5% D041	3	2000	1.92	2000	†

Type No.	Grp/Description	Per Unit Sugg.		Factory Order	Incrmnt	
		Resale Price	Price			
1N5927B	A ZEN12V1.5W5% D041	3	2000	1.68	2000	†
1N5927BRL	A ZEN12V DO41 T/R	3	6000	1.76	6000	†
1N5928BRL	A LAST ORDER DATE:06/06/98	2	6000	.60	6000	†
1N5929B	A ZEN15V1.5W5% D041	3	2000	1.68	2000	†
1N5929BRL	A REEL PK FOR1N5929B	2	6000	.39	6000	†
1N5930B	A ZEN16V1.5W5% D041	3	2000	1.68	2000	†
1N5931B	A ZEN18V1.5W5% D041	3	2000	.96	2000	†
1N5931BRL	A ZEN DIODE	2	6000	.39	6000	†
1N5932B	A ZEN20V1.5W5% D041	3	2000	1.68	2000	†
1N5932BRL	A ZEN DIODE	2	6000	.40	6000	†
1N5933B	A ZEN22V1.5W5% D041	3	2000	.96	2000	†
1N5934B	A ZEN24V1.5W5% D041	3	2000	.96	2000	†
1N5934BRL	A ZEN DIODE	2	6000	.40	6000	†
1N5935B	A ZEN27V1.5W5% D041	3	2000	.96	2000	†
1N5935BRL	A REEL PK/1N5935B	2	6000	.39	6000	†
1N5936B	A ZEN30V1.5W5% D041	3	2000	1.68	2000	†
1N5936BRL	A REEL PK FOR1N5936B	2	6000	.40	6000	†
1N5937B	A ZEN33V1.5W5% D041	3	2000	1.68	2000	†
1N5937BRL	A ZEN DIODE	3	6000	.91	6000	†
1N5938B	A ZEN36V1.5W5% D041	3	2000	1.87	2000	†
1N5939B	A LAST ORDER DATE:06/06/98	3	2000	1.68	2000	†
1N5940BRL	A ZEN DIODE	2	6000	.40	6000	†
1N5941B	A ZEN47V1.5W5% D041	3	2000	1.68	2000	†
1N5941BRL	A ZEN DIODE	2	6000	.39	6000	S †
1N5943B	A ZEN56V1.5W5% D041	3	2000	1.68	2000	†
1N5944B	A ZEN62V1.5W5% D041	N	2000	.62	2000	S †
1N5944BRL	A ZEN DIODE	2	6000	.40	6000	†
1N5945B	A ZEN68V1.5W5% D041	N	2000	1.26	2000	S †
1N5946B	A ZEN75V1.5W5% D041	3	2000	1.68	2000	†
1N5946BRL	A REEL PK/1N5946B	2	6000	.39	6000	†
1N5947BRL	A ZEN DIODE	2	6000	.40	6000	†
1N5948B	A ZEN91V1.5W5% D041	N	2000	.41	2000	S †
1N5949B	A LAST ORDER DATE:06/06/98	3	2000	1.73	2000	†
1N5950B	A ZEN110V1.5W5% D041	N	2000	1.32	2000	S †
1N5950BRL	A ZEN DIODE	2	6000	.40	6000	†
1N5951B	A ZEN120V1.5W5% D041	3	2000	1.68	2000	†
1N5952BRL	A ZEN DIODE	2	6000	.40	6000	†
1N5953B	A ZEN150V1.5W5% D041	3	2000	1.76	2000	†
1N5953BRL	A REEL PACK/1N5953B	2	6000	.39	6000	†
1N5954B	A ZEN160V1.5W5% D041	3	2000	1.28	2000	†
1N5954BRL	A ZEN160V DO41 T/R	3	6000	1.76	6000	†
1N5955B	A ZEN180V1.5W5% D041	3	2000	1.76	2000	†
1N5955BRL	A ZEN180V1.5W5% D041	2	6000	.39	6000	†
1N5956B	A ZEN200V1.5W5% D041	2	2000	.84	2000	†
1N5956BRL	A REEL PK FOR1N5956B	2	6000	.84	6000	†

A = OSPD/Power
 B = Analog/Logic
 J = Transportation
 L = Consumer
 N = Networking
 V = Wireless

S = Proprietary Device
 B = Motorola Blue Chip Program Device
 P = Phoenix Program
 * = First Time in Book
 † \$200 Minimum Waived

N = Key New Motorola Device
 R = Key "Focus" Motorola Device

1 = Mature, Stable, High-Volume Device
 2 = Moderate-Volume Device
 3 = Low-Volume Device

COMMERCIAL COMPONENTS

Type No.	Grp/Description	Per Unit Sugg.		Factory Order	Incrrmnt		Type No.	Grp/Description	Per Unit Sugg.		Factory Order	Incrrmnt	
		PC Qty	Price						PC Qty	Price			
1N5985B	A ZEN2.4V0.5W5%D035	3	3000	1.20	3000	†	1N6003B	A ZEN13V0.5W5%D035	3	3000	.55	3000	†
1N5985BRL	A ZEN2.4V DO35 T/R	3	5000	.64	5000	†	1N6003BRL	A ZEN13V DO35 T/R	3	5000	.64	5000	†
1N5986BRL	A ZEN2.7V DO35 T/R	3	5000	2.21	5000	†	1N6003C	A LAST ORDER DATE:03/15/98	3	3000	1.76	3000	†
1N5987B	A ZEN3.0V0.5W5%D035	3	3000	1.20	3000	†	1N6004B	A ZEN15V0.5W5%D035	3	3000	.55	3000	†
1N5987BRL	A ZEN3.0V DO35 T/R	3	5000	1.28	5000	†	1N6004BRL	A ZEN15V DO35 T/R	3	5000	.64	5000	†
1N5988B	A ZEN3.3V0.5W5%D035	3	3000	.55	3000	†	1N6006B	A ZEN18V0.5W5%D035	3	3000	.55	3000	†
1N5988BRL	A ZEN3.3V DO35 T/R	3	5000	.35	5000	†	1N6006BRL	A ZEN18V DO35 T/R	3	5000	.35	5000	†
1N5989B	A ZEN3.6V0.5W5%D035	3	3000	.55	3000	†	1N6007BRL	A ZEN20V0.5W5%D035	3	5000	.35	5000	†
1N5989BRL	A ZEN3.6V DO35 T/R	3	5000	.64	5000	†	1N6010BRL	A ZEN27V DO35 T/R	3	5000	.35	5000	†
1N5989C	A LAST ORDER DATE:03/15/98	3	3000	1.00	3000	†	1N6013BS	A ZEN36V0.5W5%D035	N	3000	.05	3000	★
1N5990B	A ZEN3.9V0.5W5%D035	3	3000	.55	3000	†	1N6013BSRL	A ZEN36V DO35 T/R	N	5000	.05	5000	★
1N5990BRL	A ZEN3.9V DO35 T/R	3	5000	.64	5000	†	1N6267A	A ZEN6.8V1500W5%C41-11	1	500	.69	500	†
1N5991B	A ZEN4.3V0.5W5%D035	3	3000	.55	3000	†	1N6267ARL4	A ZEN6.8V1500W5%T/R	2	1500	.69	1500	†
1N5991BRL	A ZEN4.3V DO35 T/R	3	5000	.64	5000	†	1N6269A	A ZEN8.2V1500W5%C41-11	3	500	1.36	500	†
1N5992B	A ZEN4.7V0.5W5%D035	3	3000	.55	3000	†	1N6270A	A ZEN9.1V1500W5%C41-11	N	500	.68	500	†
1N5992BRL	A ZEN4.7V DO35 T/R	3	5000	.64	5000	†	1N6270ARL4	A ZENER DIODE	2	1500	.68	1500	†
1N5992BS	A ZEN4.7V0.5W5%D035	N	3000	.05	3000	★	1N6271A	A ZEN10V1500W5%C41-11	2	500	.68	500	†
1N5992BSRL	A ZEN4.7V DO35 T/R	N	5000	.05	5000	★	1N6273A	A ZEN12V1500W5%C41-11	2	500	.68	500	†
1N5993B	A ZEN5.1V0.5W5%D035	3	3000	.55	3000	†	1N6274A	A ZEN13V1500W5%C41-11	2	500	.69	500	†
1N5993BRL	A ZEN5.1V DO35 T/R	3	5000	.35	5000	†	1N6275A	A ZEN15V1500W5%C41-11	2	500	.69	500	†
1N5993C	A LAST ORDER DATE:03/15/98	3	3000	1.00	3000	†	1N6275ARL4	A ZENER DIODE	2	1500	.70	1500	†
1N5993D	A ZEN5.1V1%D035	2	3000	.80	3000	†	1N6276A	A ZEN16V1500W5%C41-11	2	500	.68	500	†
1N5993DRL	A ZEN5.1V1%D035	3	5000	1.64	5000	†	1N6277A	A ZEN18V1500W5%C41-11	1	500	.68	500	†
1N5994B	A ZEN5.6V0.5W5%D035	3	3000	.55	3000	†	1N6277ARL4	A ZENER DIODE	2	1500	.68	1500	†
1N5994BRL	A ZEN5.6V DO35 T/R	2	5000	.14	5000	†	1N6278A	A ZEN20V1500W5%C41-11	2	500	.68	500	†
1N5994BS	A ZEN5.6V0.5W5%D035	N	3000	.05	3000	★	1N6278ARL4	A ZENER DIODE	2	1500	.68	1500	†
1N5994BSRL	A ZEN5.6V DO35 T/R	N	5000	.05	5000	★	1N6279ARL4	A ZENER DIODE	2	1500	.68	1500	†
1N5995B	A ZEN6.2V0.5W5%D035	3	3000	.55	3000	†	1N6280A	A ZEN24V1500W5%C41-11	1	500	.69	500	†
1N5995BRL	A ZEN6.2V DO35 T/R	3	5000	.35	5000	†	1N6280ARL4	A ZENER DIODE	2	1500	.70	1500	†
1N5995C	A LAST ORDER DATE:03/15/98	3	3000	1.00	3000	†	1N6281A	A ZEN27V1500W5%C41-11	2	500	.68	500	†
1N5996B	A ZEN6.8V0.5W5%D035	3	3000	.55	3000	†	1N6281ARL4	A ZENER DIODE	2	1500	.68	1500	†
1N5996BRL	A ZEN6.8V DO35 T/R	3	5000	.64	5000	†	1N6282A	A ZEN30V1500W5%C41-11	1	500	.69	500	†
1N5996BS	A ZEN6.8V0.5W5%D035	N	3000	.05	3000	★	1N6282ARL4	A ZENER DIODE	2	1500	.70	1500	†
1N5996BSRL	A ZEN6.8V DO35 T/R	N	5000	.05	5000	★	1N6283A	A ZEN33V1500W5%C41-11	2	500	.70	500	†
1N5997B	A ZEN7.5V0.5W5%D035	3	3000	.55	3000	†	1N6283ARL4	A ZENER DIODE	2	1500	.70	1500	†
1N5997BRL	A ZEN7.5V DO35 T/R	3	5000	.64	5000	†	1N6284A	A ZEN36V1500W5%C41-11	2	500	.69	500	†
1N5998B	A ZEN8.2V0.5W5%D035	3	3000	.55	3000	†	1N6284ARL4	A ZENER DIODE	2	1500	.70	1500	†
1N5998BRL	A ZEN8.2V DO35 T/R	3	5000	.35	5000	†	1N6285A	A ZEN39V1500W5%C41-11	2	500	.69	500	†
1N5999B	A ZEN9.1V0.5W5%D035	3	3000	.55	3000	†	1N6285ARL4	A ZENER DIODE	2	1500	.70	1500	†
1N5999BRL	A ZEN9.1V DO35 T/R	3	5000	.64	5000	†	1N6286A	A ZEN43V1500W5%C41-11	2	500	.68	500	†
1N6000B	A ZEN10V0.5W5%D035	3	3000	.55	3000	†	1N6286ARL4	A ZENER DIODE	2	1500	.68	1500	†
1N6000BRL	A ZEN10V DO35 T/R	3	5000	.64	5000	†	1N6287A	A ZEN47V1500W5%C41-11	2	500	.68	500	†
1N6001BRL	A ZEN11V DO35 T/R	3	5000	.64	5000	†	1N6288A	A ZEN51V1500W5%C41-11	2	500	.69	500	†
1N6002B	A ZEN12V0.5W5%D035	3	3000	.55	3000	†	1N6288ARL4	A ZENER DIODE	2	1500	.70	1500	†
1N6002BRL	A ZEN12V DO35 T/R	3	5000	.64	5000	†	1N6289A	A ZEN56V1500W5%C41-11	2	500	.69	500	†

A = OSPD/Power
 B = Analog/Logic
 J = Transportation
 L = Consumer
 N = Networking
 V = Wireless

S = Proprietary Device
 B = Motorola Blue Chip Program Device
 P = Phoenix Program
 ★ = First Time in Book
 † \$200 Minimum Waived

N = Key New Motorola Device
 R = Key "Focus" Motorola Device

1 = Mature, Stable, High-Volume Device
 2 = Moderate-Volume Device
 3 = Low-Volume Device

EFFECTIVE DATE: JANUARY 10, 1998

COMMERCIAL COMPONENTS

Type No.	Grp/Description	Per Unit Sugg.		Factory Order	Incrmnt	
		Resale Price	Price			
1N6290A	A ZEN62V1500W5% C41-11	2	500	.69	500	†
1N6290ARL4	A ZENER DIODE	2	1500	.70	1500	†
1N6291A	A ZEN68V1500W5% C41-11	2	500	.68	500	†
1N6291ARL4	A ZEN68V1500W5% T/R	2	1500	.96	1500	†
1N6292A	A ZEN75V1500W5% C41-11	3	500	1.36	500	†
1N6292ARL4	A ZENER DIODE	2	1500	.96	1500	†
1N6293ARL4	A ZENER DIODE	2	1500	.68	1500	†
1N6294A	A ZEN91V1500W5% C41-11	2	500	.68	500	†
1N6294ARL4	A ZEN91V1500W5% T/R	2	1500	.68	1500	†
1N6295A	A ZEN100V1500W5% C41-11	2	500	1.12	500	†
1N6299A	A ZEN150V1500W5% C41-11	2	500	1.12	500	†
1N6300A	A ZEN160V1500W5% C41-11	3	500	1.93	500	†
1N6302A	A ZEN180V1500W5% C41-11	2	500	1.12	500	†
1N6303A	A ZEN200V1500W5% C41-11	2	500	1.12	500	†
1N6373	A ZEN6.0V1500WC41-11	1	500	.69	500	†
1N6373RL4	A HIPWR SURMETIC TRANS SUP	2	1500	.70	1500	†
1N6374	A ZEN9.4V1500WC41-11	2	500	.68	500	†
1N6375	A ZEN11.7V1500WC41-11	3	500	1.36	500	†
1N6376	A ZEN14.1V1500WC41-11	2	500	.69	500	†
1N6376RL4	A HIPWR SURMETIC TRANS SUP	2	1500	.70	1500	†
1N6377	A ZEN17.6V1500WC41-11	2	500	.68	500	†
1N6378	A ZEN21.2V1500WC41-11	3	500	1.36	500	†
1N6379	A ZEN25.9V1500WC41-11	2	500	.68	500	†
1N6380	A ZEN42.4V1500WC41-11	2	500	.68	500	†
1N6381	A ZEN52.9V1500WC41-11	3	500	1.40	500	†
1N6382	A ZEN9.4V CLIPPER	3	500	1.92	500	†
1N6383	A ZEN11.7V CLIPPER	3	500	1.92	500	†
1N6384	A ZEN14.1V CLIPPER	2	500	.96	500	†
1N6385	A ZEN17.6V CLIPPER	2	500	.96	500	†
1N6386	A ZEN21.2V CLIPPER	2	500	.96	500	†
1N6387	A ZEN25.9V CLIPPER	3	500	1.92	500	†
1N6388	A ZEN42.4V CLIPPER	2	500	.96	500	†
1N6389	A ZEN52.9V CLIPPER	3	500	1.92	500	†
1N746A	A ZEN3.3V0.4W5% DO35	2	3000	.076	3000	†
1N746ARL	A ZEN3.3V DO35 T/R	2	5000	.086	5000	†
1N747ARL	A ZEN3.6V DO35 T/R	2	5000	.086	5000	†
1N748ARL	A ZEN3.9V DO35 T/R	2	5000	.086	5000	†
1N749A	A LAST ORDER DATE:03/15/98	2	3000	.076	3000	†
1N749ARL	A ZEN4.3V DO35 T/R	2	5000	.086	5000	†
1N750A	A ZEN4.7V0.4W5% DO35	2	3000	.076	3000	†
1N750ARL	A ZEN4.7V DO35 T/R	2	5000	.086	5000	†
1N751A	A ZEN5.1V0.4W5% DO35	1	3000	.08	3000	†
1N751ARL	A ZEN5.1V DO35 T/R	1	5000	.09	5000	†
1N751AS	A ZEN5.1V0.4W5% DO35	N	3000	.05	3000 ★	†
1N751ASRL	A ZEN5.1V DO35 T/R	N	5000	.05	5000 ★	†

Type No.	Grp/Description	Per Unit Sugg.		Factory Order	Incrmnt	
		Resale Price	Price			
1N752A	A ZEN5.6V0.4W5% DO35	2	3000	.076	3000	†
1N752ARL	A ZEN5.6V DO35 T/R	1	5000	.086	5000	†
1N752AS	A ZEN5.6V0.4W5% DO35	N	3000	.05	3000 ★	†
1N752ASRL	A ZEN5.6V DO35 T/R	N	5000	.05	5000 ★	†
1N753A	A ZEN6.2V0.4W5% DO35	2	3000	.076	3000	†
1N753ARL	A ZEN6.2V DO35 T/R	1	5000	.086	5000	†
1N753AS	A ZEN6.2V0.4W5% DO35	N	3000	.05	3000 ★	†
1N753ASRL	A ZEN6.2V DO35 T/R	N	5000	.05	5000 ★	†
1N754A	A ZEN6.8V0.4W5% DO35	2	3000	.076	3000	†
1N754ARL	A ZEN6.8V DO35 T/R	2	5000	.086	5000	†
1N755ARL	A ZEN7.5V DO35 T/R	2	5000	.086	5000	†
1N756ARL	A ZEN8.2V DO35 T/R	2	5000	.086	5000	†
1N757ARL	A ZEN9.1V DO35 T/R	2	5000	.086	5000	†
1N758A	A ZEN10V0.4W5% DO35	2	3000	.076	3000	†
1N758ARL	A ZEN10V DO35 T/R	2	5000	.086	5000	†
1N759A	A LAST ORDER DATE:03/15/98	2	3000	.076	3000	†
1N759ARL	A ZEN12V DO35 T/R	2	5000	.086	5000	†
1N821ARL	A ZEN6.2V DO35 T/R	2	5000	.99	5000	†
1N821RL	A ZEN6.2V DO35 T/R	3	5000	1.98	5000	†
1N823	A ZEN6.2V0.4W.005% TC DO35	2	500	.99	500	†
1N823A	A ZEN6.2V0.4W.005% TC DO35	2	500	.99	500	†
1N823ARL	A ZEN6.2V DO35 T/R	2	5000	.99	5000	†
1N823RL	A ZEN6.2V DO35 T/R	3	5000	1.98	5000	†
1N825	A ZEN6.2V0.4W.002% TC DO35	2	500	.99	500	†
1N825A	A ZEN6.2V0.4W.002% TC DO35	2	500	.99	500	†
1N825ARL	A ZEN6.2V DO35 T/R	1	5000	.99	5000	†
1N825RL	A ZEN6.2V DO35 T/R	3	5000	1.98	5000	†
1N827	A ZEN6.2V0.4W.001% TC DO35	2	500	1.32	500	†
1N827A	A ZEN6.2V0.4W.001% TC DO35	2	500	2.20	500	†
1N827ARL	A ZEN6.2V DO35 T/R	3	5000	3.36	5000	†
1N827RL	A ZEN6.2V DO7 T/R	3	5000	2.31	5000	†
1N829A	A ZEN6.2V0.4W.0005% TC DO35	2	500	3.20	500	†
1N829ARL	A ZEN6.2V0.4W.0005% TC T/R	3	5000	4.88	5000	†
1N829RL	A ZEN6.2V DO35 T/R	3	5000	6.73	5000	†
1N958B	A LAST ORDER DATE:03/15/98	N	3000	.15	3000	†
1N959B	A LAST ORDER DATE:03/15/98	2	3000	.15	3000	†
1N961B	A LAST ORDER DATE:03/15/98	2	3000	.076	3000	†
1N961BRL	A ZEN10V DO35 T/R	2	5000	.086	5000	†
1N962BRL	A ZEN11V DO35 T/R	2	5000	.086	5000	†
1N963B	A LAST ORDER DATE:03/15/98	2	3000	.076	3000	†
1N963BRL	A ZEN12V DO35 T/R	2	5000	.086	5000	†
1N965B	A ZEN15V0.4W5% DO35	2	3000	.076	3000	†
1N965BRL	A ZEN15V DO35 T/R	2	5000	.086	5000	†
1N967BRL	A ZEN18V DO35 T/R	2	5000	.086	5000	†
1N968BRL	A ZEN20V DO35 T/R	2	5000	.086	5000	†

A = OSPD/Power
 B = Analog/Logic
 J = Transportation
 L = Consumer
 N = Networking
 V = Wireless

S = Proprietary Device
 B = Motorola Blue Chip Program Device
 P = Phoenix Program
 ★ = First Time in Book
 † \$200 Minimum Waived

N = Key New Motorola Device
 R = Key "Focus" Motorola Device

1 = Mature, Stable, High-Volume Device
 2 = Moderate-Volume Device
 3 = Low-Volume Device