

THOMSON SEMICONDUCTORS

LM138
LM238
LM338

THREE-TERMINAL 5-A ADJUSTABLE VOLTAGE REGULATORS

The LM138/LM238/LM338 are adjustable 3-terminal positive voltage regulators capable of supplying in excess of 5 A over a 1.2 V to 32 V output range. They are exceptionally easy to use and require only 2 resistors to set the output voltage. Careful circuit design has resulted in outstanding load and line regulation - comparable to many commercial power supplies. The LM138 family is supplied in a standard 3-lead transistor package.

A unique feature of the LM138 family is time-dependent current limiting. The current limit circuitry allows peak currents of up to 12 A to be drawn from the regulator for short periods of time. This allows the LM138 to be used with heavy transient loads and speeds start-up under full-load conditions. Under sustained loading conditions, the current limit decreases to a safe value protecting the regulator. Also included on the chip are thermal overload protection and safe area protection for the power transistor. Overload protection remains functional even if the adjustment pin is accidentally disconnected.

Normally, no capacitors are needed unless the device is situated far from the input filter capacitors in which case an input bypass is needed. An optional output capacitor can be added to improve transient response. The adjustment terminal can be bypassed to achieve very high ripple rejection ratios which are difficult to achieve with standard 3-terminal regulators.

Besides replacing fixed regulators or discrete designs, the LM138 is useful in a wide variety of other applications. Since the regulator is "floating" and sees only the input-to-output differential voltage, supplies of several hundred volts can be regulated as long as the maximum input to input differential is not exceeded.

The LM128/LM228/LM338 are packaged in standard steel TO-3 transistor packages. The LM138 is rated for operation from -55°C to +150°C, the LM238 from -25°C to +150°C and the LM338 from 0°C to +125°C.

- Guaranteed 7 A peak output current.
- Guaranteed 5 A output current.
- Adjustable output down to 1.2 V
- Line regulation typically 0.005%/V
- Load regulation typically 0.1%.
- Guaranteed thermal regulation.
- Current limit constant with temperature.
- Standard 3-lead transistor package.

ORDERING INFORMATION

Hi-Rel versions available - See chapter 14

PART NUMBER	TEMPERATURE RANGE	PACKAGE
		K
LM138	-55°C to +150°C	•
LM238	-25°C to +150°C	•
LM338	0°C to +125°C	•

Example : LM138K

THREE-TERMINAL 5-A ADJUSTABLE VOLTAGE REGULATORS

CASE CB-19
(TO-3)

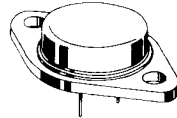

K SUFFIX
STEEL CAN

PIN ASSIGNMENT

(Bottom view)

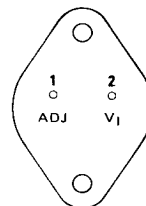

Case is output

THOMSON SEMICONDUCTORS

Sales headquarters
45, av. de l'Europe - 78140 VELIZY - FRANCE
Tel. : (3) 946 97 19 / Telex : 204780 F

393

 **THOMSON**
COMPONENTS

Ref. 00075

MAXIMUM RATINGS

Rating	Symbol	Value	Unit
Power dissipation	P_{tot}	Internally limited	W
Input-output voltage differential	$V_I - V_O$	35	V
Operating junction temperature range	T_{oper}	-55 to +150 -25 to +150 0 to +125	°C
Storage temperature range	T_{stg}	-65 to +150	°C
Lead temperature (Soldering, 10 seconds)	T_{lead}	300	°C

THERMAL CHARACTERISTICS

Rating	Symbol	Value	Unit
Maximum junction-case thermal resistance	$R_{th(j-c)}$	4	°C/W
Typical junction-ambient thermal resistance	$R_{th(j-a)}$	35	°C/W

SCHEMATIC DIAGRAM

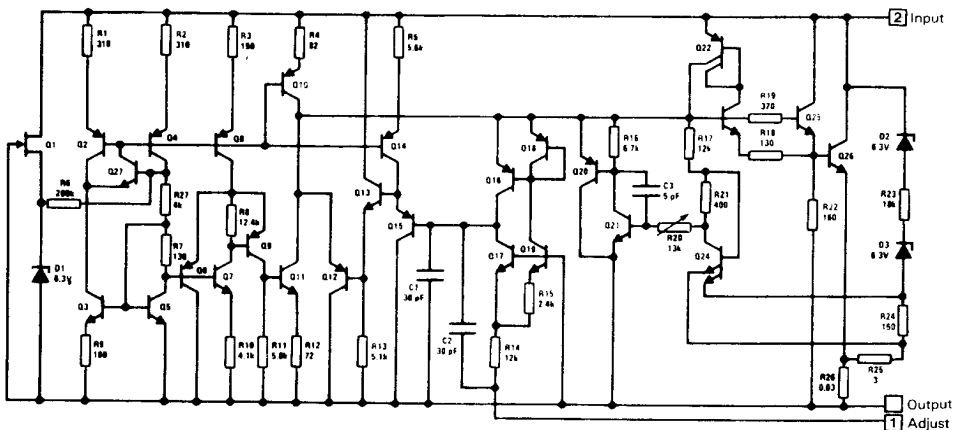

ELECTRICAL CHARACTERISTICS

LM138 : $-55^{\circ}\text{C} \leq T_j \leq +150^{\circ}\text{C}$, $V_I - V_O = +5\text{ V}$, $I_O = 2.5\text{ A}$

LM238 : $-25^{\circ}\text{C} \leq T_j \leq +150^{\circ}\text{C}$, $V_I - V_O = +5\text{ V}$, $I_O = 2.5\text{ A}$

LM338 : $0^{\circ}\text{C} \leq T_j \leq +150^{\circ}\text{C}$, $V_I - V_O = +5\text{ V}$, $I_O = 2.5\text{ A}$

Although power dissipation is internally limited, these specifications apply to power dissipation up to 50 W. (Unless otherwise specified)

Characteristic	Symbol	LM138 - LM238			LM338			Unit
		Min	Typ	Max	Min	Typ	Max	
Line regulation - (Note 1) $T_{\text{amb}} = +25^{\circ}\text{C}$, $+3\text{ V} \leq (V_I - V_O) \leq +35\text{ V}$	K_{V_I}	—	0.005	0.01	—	0.005	0.03	%/V
Load regulation $T_{\text{amb}} = +25^{\circ}\text{C}$, $10\text{ mA} \leq I_O \leq 5\text{ A}$ $V_O \leq +5\text{ V}$ - (Note 1) $V_O \geq +5\text{ V}$ - (Note 1)	K_{V_O}	—	5 0.1	15 0.3	—	5 0.1	25 0.5	mV %
Thermal regulation (Pulse = 20 ms)	—	—	0.002	0.01	—	0.002	0.02	%/W
Adjustment pin current	I_{adj}	—	45	100	—	45	100	μA
Adjustment pin current change $10\text{ mA} \leq I_L \leq 5\text{ A}$, $+3\text{ V} \leq (V_I - V_O) \leq +35\text{ V}$	ΔI_{adj}	—	0.2	5	—	0.2	5	μA
Reference voltage $(+3\text{ V} \leq (V_I - V_O) \leq +35\text{ V}$, $10\text{ mA} \leq I_O \leq 5\text{ A}$, $P \leq 50\text{ W}$)	$V(\text{ref})$	1.19	1.24	1.29	1.19	1.24	1.29	V
Line regulation $+3\text{ V} \leq (V_I - V_O) \leq +35\text{ V}$ - (Note 1)	K_{V_I}	—	0.02	0.04	—	0.02	0.06	%/V
Load regulation (10 mA $\leq I_O \leq 5\text{ A}$) - Note 1 $V_O \leq +5\text{ V}$ $V_O \geq +5\text{ V}$	K_{V_O}	—	20 0.3	30 0.6	—	20 0.3	50 1.0	mV %
Temperature stability ($T_{\text{min}} \leq T_j \leq T_{\text{max}}$)	K_{V_T}	—	1	—	—	1	—	%
Minimum load current ($V_I - V_O = +35\text{ V}$)	$I_{O(\text{min})}$	—	3.5	5	—	3.5	10	mA
Current limit ($V_I - V_O \leq +10\text{ V}$) DC 0.5 ms Peak $V_I - V_O = +30\text{ V}$	$I_{O(\text{max})}$	5.0 7 —	8 12 1	— — —	5.0 7 —	8 12 1	— — —	A
RMS output noise, % of V_O ($T_{\text{amb}} = +25^{\circ}\text{C}$, 10 Hz $\leq f \leq 10\text{ kHz}$)	—	—	0.003	—	—	0.003	—	%
Ripple rejection ratio $V_O = +10\text{ V}$, $f = 120\text{ Hz}$ $C_{\text{adj}} = 10\text{ }\mu\text{F}$	R_{v_f}	—	60 75	— —	—	60 75	— —	dB
Long term stability ($T_{\text{amb}} = +125^{\circ}\text{C}$)	K_{V_H}	—	0.3	1	—	0.3	1	%

Note 1 : Regulation is measured at constant junction temperature. Changes in output voltage due to heating effects are taken into account separately by thermal rejection.

CURRENT LIMIT

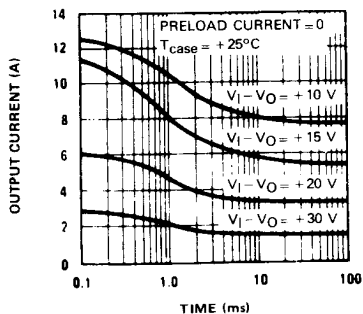

CURRENT LIMIT

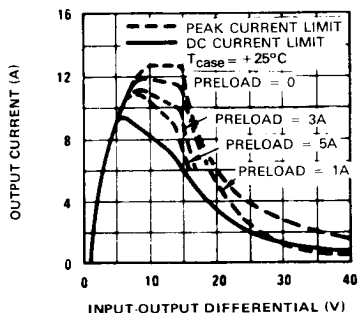

CURRENT LIMIT

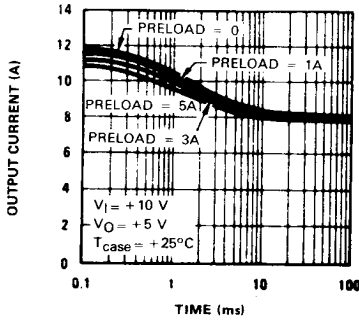

LOAD REGULATION

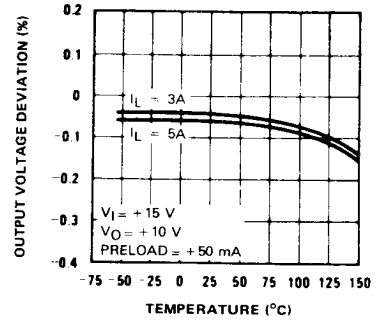

DROPOUT VOLTAGE

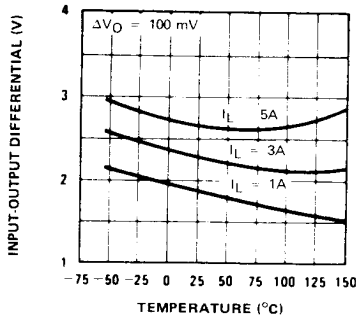

ADJUSTMENT CURRENT

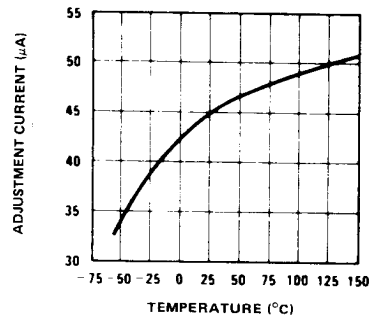

TEMPERATURE STABILITY

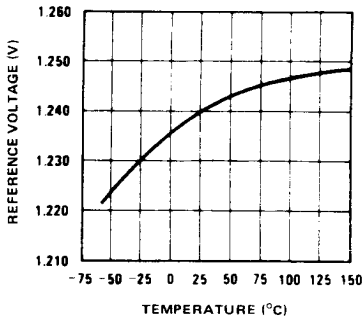

OUTPUT IMPEDANCE

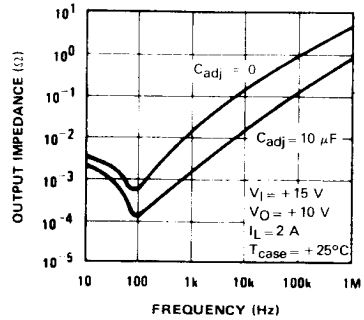

MINIMUM OPERATING CURRENT

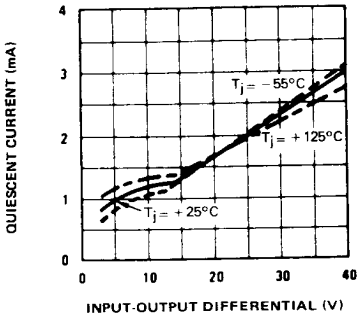

RIPPLE REJECTION

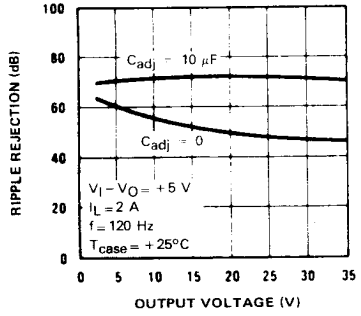

RIPPLE REJECTION

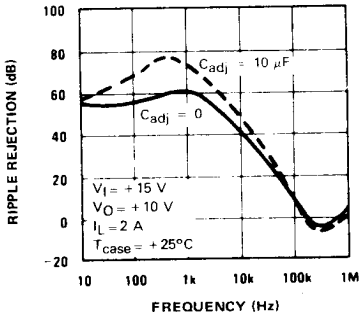

RIPPLE REJECTION

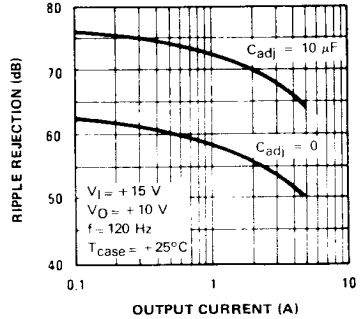

LINE TRANSIENT RESPONSE

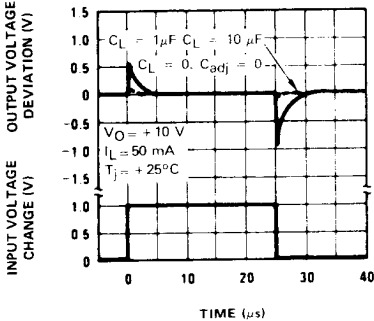

LOAD TRANSIENT RESPONSE

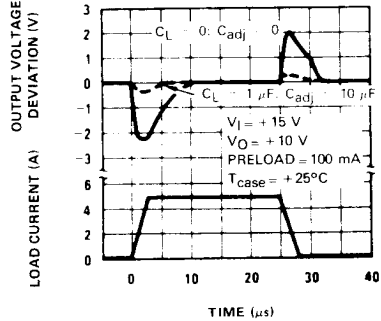

TYPICAL APPLICATIONS

+1.2 V to +25 V ADJUSTABLE REGULATOR

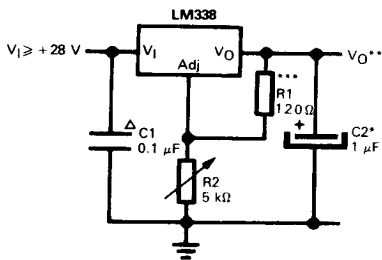

*Optional—improves transient response. Output capacitors in the range of 1 μF to 100 μF of aluminium or tantalum electrolytic are commonly used to provide improved output impedance and rejection of transients.

Δ Needed if device is far from filter capacitors.

$$^{**} V_O = 1.25 \text{ V} \left(1 + \frac{R_2}{R_1} \right)$$

*** $R_1 = 240 \Omega$ for LM138 and LM238

APPLICATION HINTS

In operation, the LM338 develops a nominal 1.25 V reference voltage, $V_{(\text{ref})}$, between the output and adjustment terminal. The reference voltage is impressed across program resistor R_1 and, since the voltage is constant, a constant current I_1 then flows through the output set resistor R_2 , giving an output voltage of

$$V_O = V_{(\text{ref})} \left(1 + \frac{R_2}{R_1} \right) + I_{\text{adj}} R_2$$

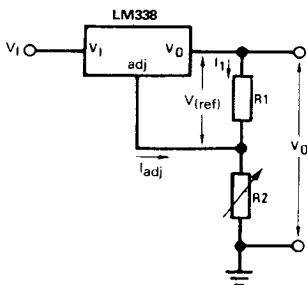

FIGURE 1

Since the 50 μA current from the adjustment terminal represents an error term, the LM338 was designed to minimize I_{adj} and make it very constant with line and load changes. To do this, all quiescent operating current is returned to the output establishing a minimum load current requirement. If there is insufficient load on the output, the output will rise.

External Capacitors

An input bypass capacitor is recommended. A 0.1 μF disc or 1 μF solid tantalum on the input is suitable input bypassing for almost all applications. The device is more sensitive to the absence of input bypassing when adjustment or output capacitors are used but the above values will eliminate the possibility of problems.

The adjustment terminal can be bypassed to ground on the LM338 to improve ripple rejection. This bypass capacitor prevents ripple from being amplified as the output voltage is increased. With a 10 μF bypass capacitor 75 dB ripple rejection is obtainable at any output level. Increases over 20 μF do not appreciably improve the ripple rejection at frequencies above 120 Hz. If the bypass capacitor is used, it is sometimes necessary to include protection diodes to prevent the capacitor from discharging through internal low current paths and damaging the device.

In general, the best type of capacitors to use are solid tantalum. Solid tantalum capacitors have low impedance even at high frequencies. Depending upon capacitor construction, it takes about 25 μF in aluminum electrolytic to equal 1 μF solid tantalum at high frequencies. Ceramic capacitors are also good at high frequencies, but some types have a large decrease in capacitance at frequencies around 0.5 MHz. For this reason, 0.01 μF disc may seem to work better than a 0.1 μF disc as a bypass.

Although the LM338 is stable with no output capacitors, like any feedback circuit, certain values of external capacitance can cause excessive ringing. This occurs with values between 500 pF and 5000 pF. A 1 μF solid tantalum (or 25 μF aluminium electrolytic) on the output swamps this effect and insures stability.

Load Regulation

The LM338 is capable of providing extremely good load regulation but a few precautions are needed to obtain maximum performance. The current set resistor connected between the adjustment terminal and the output terminal (usually 240 Ω) should be tied directly to the output of the regulator rather than near the load. This eliminates line drops from appearing effectively in series with the reference and degrading regulation. For example, a 15 V regulator with 0.05 Ω resistance between the regulator and load will have a load regulation due to line resistance of $0.05 \Omega \times I_L$. If the set resistor is connected near the load the effective line resistance will be $0.05 \Omega (1 + R_2/R_1)$ or in this case, 11.5 times worse.

Figure 2 shows the effect of resistance between the regulator and 140 Ω set resistor.

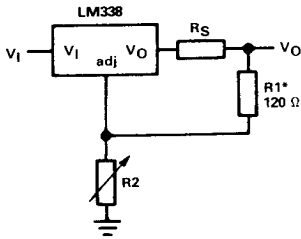

FIGURE 2 – REGULATOR WITH LINE RESISTANCE IN OUTPUT LEAD

With the TO-3 package, it is easy to minimize the resistance from the case to the set resistor, by using 2 separate leads to the case. The ground of R2 can be returned near the ground of the load to provide remote ground sensing and improve load regulation.

Protection Diodes

When external capacitors are used with any IC regulator it is sometimes necessary to add protection diodes to prevent the capacitors from discharging through low current points into the regulator. Most 20 μF capacitors have low enough internal series resistance to deliver 20A spikes when shorted. Although the surge is short, there is enough energy to damage parts of the IC.

When an output capacitor is connected to a regulator and the input is shorted, the output capacitor will discharge into the output of the regulator. The discharge current depends on the value of the capacitor, the output voltage of the regulator, and the rate of decrease of V_I. In the LM338 this discharge path is through a large junction that is able to sustain 25 A surge with no problem. This is not true of other types of positive regulators. For output capacitors of 100 μF or less at output of 15 V or less, there is no need to use diodes.

The bypass capacitor on the adjustment terminal can discharge through a low current junction. Discharge occurs when either the input or output is shorted. Internal to the LM338 is a 50 Ω resistor which limits the peak discharge current. No protection is needed for output voltages of 25 V or less and 10 μF capacitance. Figure 3 shows an LM338 with protection diodes included for use with outputs greater than 25 V and high values of output capacitance.

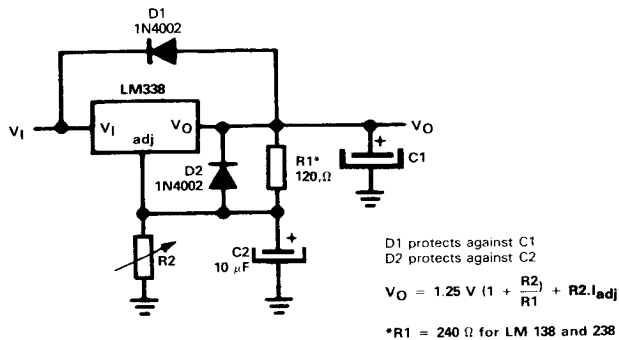
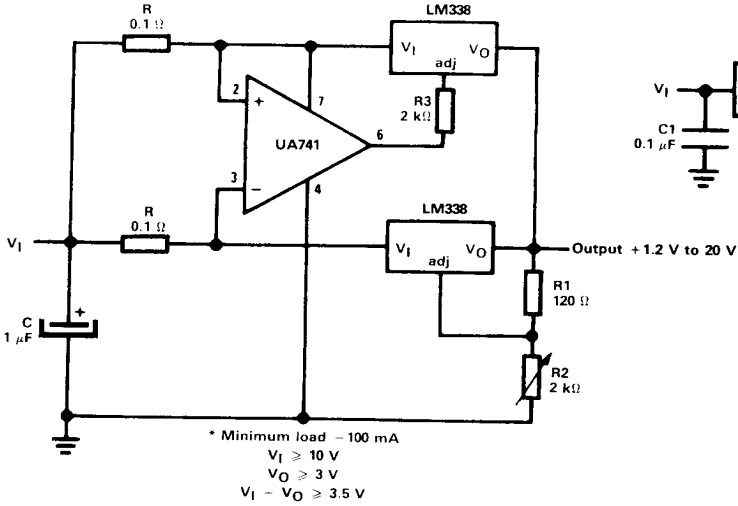
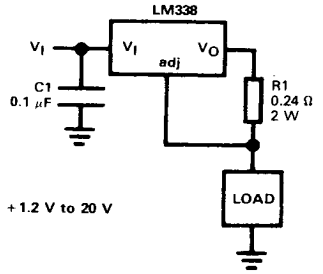

FIGURE 3 – REGULATOR WITH PROTECTION DIODES

10A REGULATOR



5A CURRENT REGULATOR



15 A REGULATOR

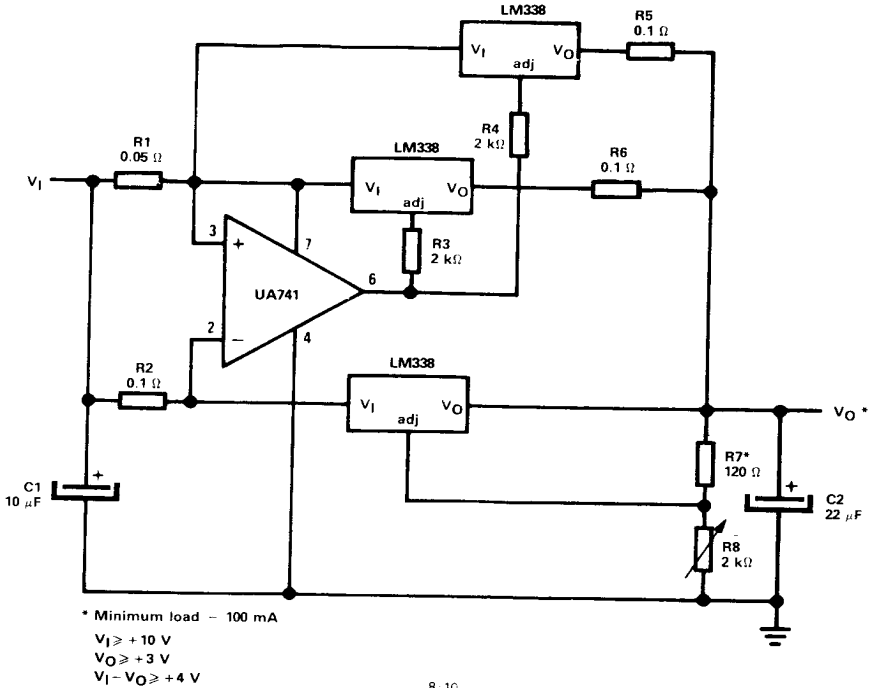

5 V LOGIC REGULATOR WITH ELECTRONIC SHUTDOWN**

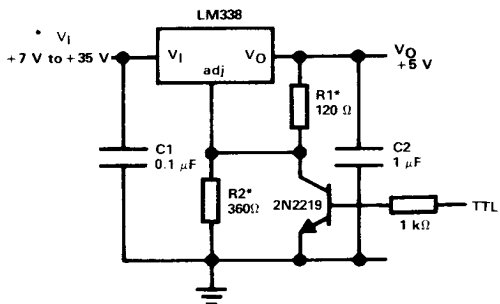

- * R1 = 240 Ω for LM138 or LM238
- * R2 = 720 Ω for LM138 or LM238
- ** Minimum output ≈ +1.2 V

TRACKING PREREGULATOR

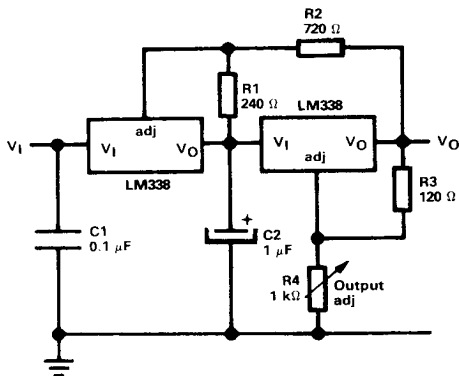

SLOW TURN-ON 15 V REGULATOR

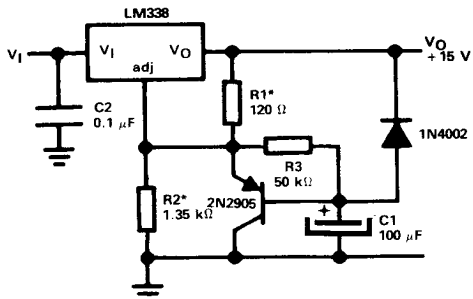

- * R1 = 240 Ω } for LM 138 and LM 238
- * R2 = 2.7 kΩ }

CB-19
(TO-3)

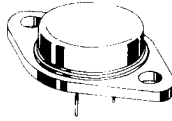

K SUFFIX
STEEL CAN

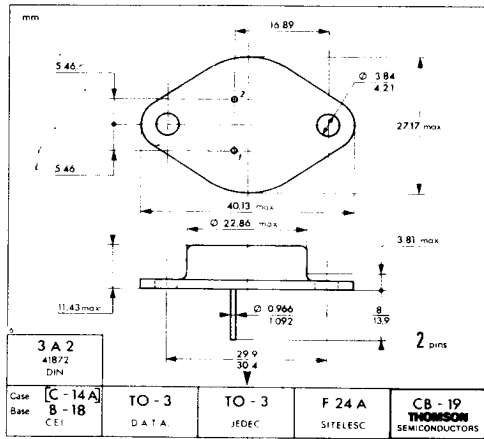

These specifications are subject to change without notice.
Please inquire with our sales offices about the availability of the different packages.

10-10

THOMSON SEMICONDUCTORS

402