	TYPE	NUMBER	
	<b>PRODUCT SPECIFICATION</b>	<b>BUS-12-023</b>	
TITLE	PAGE	REVISION	
<b>Mini-Jump – Gold or GXT Plated</b>	1 of 17	<b>FED</b>	
	AUTHORIZED BY	DATE	
	<b>H. SUNDYS.FierroJ.ZH</b> <b>OU</b>	<del>4-14-APR</del> <b>0506/12/065/1</b> <b>5/2012</b>	
	CLASSIFICATION		
	<b>CONFIDENTIAL UNRESTRICTED</b>		

**1.0 GENERAL**

Scope - This specification covers gold or gold flash over palladium alloy plated mini-jump connectors designed for low power interconnection of two adjacent 0.025 inch square pins, free standing or in headers, on 0.100 or 0.150 inch centers. This product meets the requirements of the European Union Directive of Restrictions for Hazardous Substances (Directive 2002/95/EC). This specification is composed of the following sections.

Paragraph	Title	Page
1.0	GENERAL	1
2.0	APPLICABLE DOCUMENTS	1
3.0	REQUIREMENTS	2
3.1	Qualification	2
3.2	Material	2
3.3	Finish	2
3.4	Design and Construction	3
3.5	Electrical Characteristics	3
3.6	Mechanical Characteristics	6
3.7	Environmental Conditions	7
4.0	QUALITY ASSURANCE PROVISIONS	11
4.1	Equipment Calibration	11
4.2	Inspection Conditions	12
4.3	Qualification Inspections	12
4.4	Regualification Testing	13
5.0	NOTES AND DEFINITIONS	16

Formatted: French (France)  
Formatted: Tab stops: 1.65", Left + Not at 1.58"

**2.0 APPLICABLE DOCUMENTS**

The following documents, of the issue in effect on the date of the latest revision of this specification, shall form a part of this specification to the extent specified herein.

Military Specifications

- MIL-M-24519 Molding Plastics, Polyester, Thermoplastics
- MIL-G-45204 Gold Plating, Electrodeposited
- MIL-P-45209 Palladium Plating, Electrodeposited
- MIL-C-45662 Calibration System Requirements
- MIL-P-55110 Printed Wiring Boards
- MIL-STD-105 Sampling Procedures and Tables for Inspection by Attributes
- MIL-STD-202 Test Methods for Electronic and Electrical Component Parts
- MIL-STD-275 Printed Wiring for Electronic Equipment
- MIL-STD-1344 Test Methods for Electrical Connectors

Formatted: Indent: Left: 0.42", Tab stops: 2.42", Left + 4.25", Left + 6.5", Left + Not at 2" + 2.5" + 4.17" + 6.58"

This document is the property of and embodies CONFIDENTIAL and PROPRIETARY information of FCI/FCI Electronics. No part of the information shown on this document may be used in any way without the written consent of FCI/FCI Electronics.

Form E-3005  
Rev B-07/20/04A-02/12/04  
V04-078220603 GS-01-004

Copyright FCI  
Form E-3334  
Rev E GS-01-001

	TYPE	NUMBER	
	<b>PRODUCT SPECIFICATION</b>	<b>BUS-12-023</b>	
TITLE	PAGE	REVISION	
	<b>Mini-Jump – Gold or GXT Plated</b>	2 of 17	FED
	AUTHORIZED BY	DATE	
	H: SUNDYS.FierroJ.ZH OU	<del>4-14-APR</del> 0506/12/065/1 5/2012	
CLASSIFICATION			<b>CONFIDENTIAL UNRESTRICTED</b>

Federal Specifications

- QQ-N-290 Nickel Plating (Electrodeposited)
- QQ-B-613 Brass, Leaded and Non-Leaded

Industry Specifications/Standards

- ASTM B-194 Copper-Beryllium Alloy Plate, Sheet, Strip, and Rolled Bar
- UL-94 Tests for Flammability of Plastic Materials

**3.0 REQUIREMENTS**

3.1 Qualification

Connectors furnished under this specification shall be products capable of meeting the qualification test requirements specified herein. New products of the same type shall be considered qualified by similarity pending actual testing.

3.2 Material

The material for each part shall be as specified herein, or equivalent. Substitute material shall meet the performance requirements of this specification.

3.2.1 Metallic Parts

3.2.1.1 Contact Body. The body shall be Brass alloy UNS C26000 in accordance with QQ-B-613.

3.2.1.2 Contact Spring. The spring shall be Beryllium Copper alloy UNS C17200 in accordance with ASTM B-194. After stamping, the spring shall be heat-treated to a full hard condition.

3.2.2 Insulator Housing. The housing material shall be unfilled Polyester in accordance with MIL-M-24519. The material shall be rated flame retardant 94 V-O in accordance with UL-94.

3.3 Finish

3.3.1 Contact Body. The body shall be plated in the contact area with 40 microinches (minimum) gold per MIL-C-45204 or a thin gold flash over 37 microinches (minimum) palladium alloy per MIL-P-45209, Type II, Grade C over 50 microinches (minimum) nickel per QQ-N-290, Class 2.

This document is the property of and embodies CONFIDENTIAL and PROPRIETARY information of FCI/FCI Electronics. No part of the information shown on this document may be used in any way without the written consent of FCI/FCI Electronics.

Form E-3005  
Rev B-07/20/04A-02/12/04  
V04-078220603

GS-01-004

Copyright FCI

Form E-3334  
Rev E

GS-01-001

	TYPE	NUMBER	
	<b>PRODUCT SPECIFICATION</b>	<b>BUS-12-023</b>	
TITLE	PAGE	REVISION	
<u>Mini-Jump – Gold or GXT Plated</u>	3 of 17	FED	
	AUTHORIZED BY	DATE	
	<u>H. SUNDYS.FierroJ.ZH</u> <u>OU</u>	<u>4-14-APR</u> <u>0506/12/065/1</u> <u>5/2012</u>	
	CLASSIFICATION		
	<b>CONFIDENTIAL UNRESTRICTED</b>		

3.3.2 Contact Spring. The spring shall be plated on the mating side with 3 microinches (minimum) gold per MIL-G-45204, Type II, Grade C.

3.4 Design and Construction

The connector typically shall be a two piece assembly comprising two interconnected contacts retained in a plastic housing. The female (disconnect) end of the contact shall interface with 0.025 inch square (or round) pins on 0.100 or 0.150 inch centers, as appropriate. In certain applications, the connector shall consist of the contacts without a housing.

3.4.1 Mating. The connector shall be capable of being mated or unmated by hand without the use of special tools within the specified temperature range.

3.4.2 Workmanship. Connectors shall be uniform in quality and shall be free from burrs, scratches, cracks, voids, chips, blisters, pin holes, sharp edges, and other defects that will adversely affect life or serviceability.

3.4.3 Interchangeability. The connector shall be capable of mating with any appropriately constituted male connector of the same population without degradation in performance.

3.5 Electrical Characteristics

3.5.1 Current Rating. The maximum current rating of the connector shall be 3.0 amperes DC (2.5 amperes for multi-position assembly).

3.5.2 Contact Resistance. (see 5.1) The contact resistance shall not exceed the value specified in Table 1, when measured in accordance with MIL-STD-202, Method 307. The following details shall apply:

- (a) Method of Connection - Attach current and voltage leads as shown in Figure 1.
- (b) Test Current - 1 ampere DC

This document is the property of and embodies CONFIDENTIAL and PROPRIETARY information of FCI/FCI Electronics. No part of the information shown on this document may be used in any way without the written consent of FCI/FCI Electronics.

Form E-3005  
Rev B-07/30/04A-02/12/04  
V04-078220603

GS-01-004

Copyright FCI

Form E-3334  
Rev E

GS-01-001



TYPE	<b>PRODUCT SPECIFICATION</b>	NUMBER	<b>BUS-12-023</b>
TITLE	<b>Mini-Jump – Gold or GXT Plated</b>	PAGE	4 of 17
		REVISION	<b>FED</b>
		AUTHORIZED BY	H: SUNDY S. Fierro J. ZH OU
		DATE	<del>4-14-APR</del> 05/06/12/065/1 5/2012
		CLASSIFICATION	<b>CONFIDENTIAL UNRESTRICTED</b>

**FIGURE 1 - CONTACT RESISTANCE**

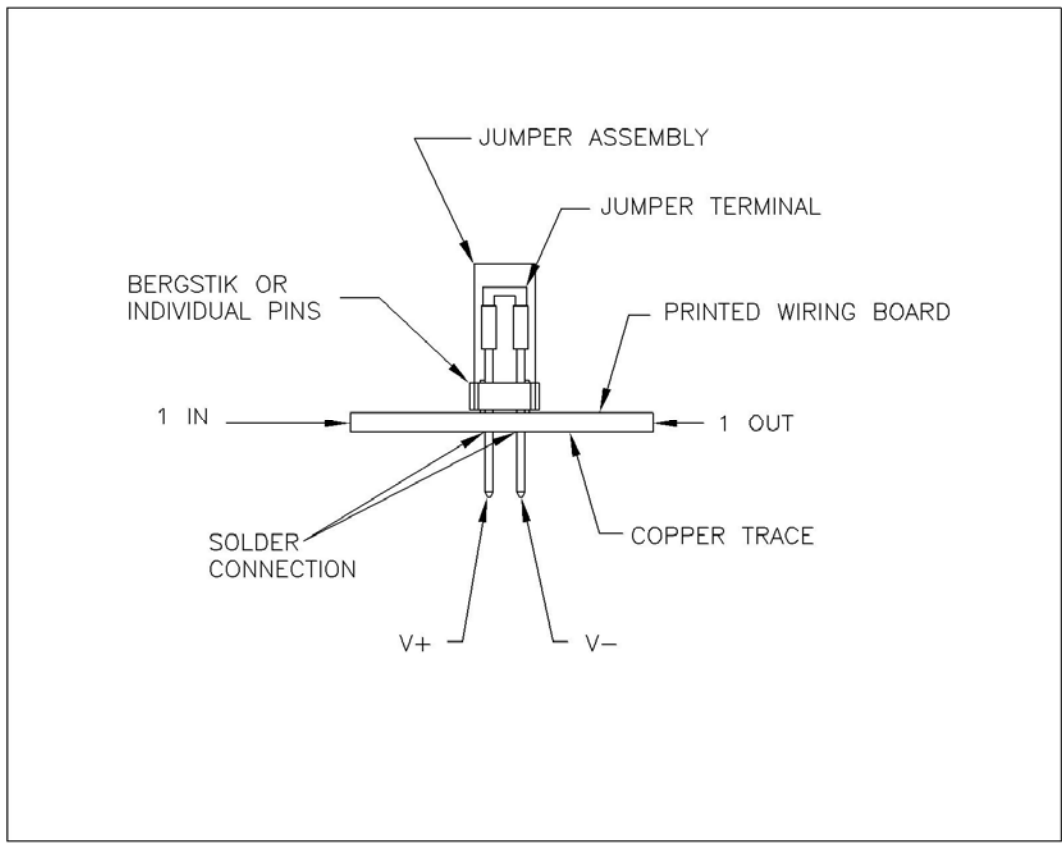

This document is the property of and embodies CONFIDENTIAL and PROPRIETARY information of FCI, FCI Electronics. No part of the information shown on this document may be used in any way without the written consent of FCI, Electronics.

Form E-3005  
Rev B-07/30/04A-02/12/04  
V04-078220603

GS-01-004

Copyright FCI

Form E-3334  
Rev E

GS-01-001

	TYPE	NUMBER	
	<b>PRODUCT SPECIFICATION</b>	<b>BUS-12-023</b>	
TITLE  <u>Mini-Jump – Gold or GXT Plated</u>	PAGE	REVISION	
	5 of 17	FED	
	AUTHORIZED BY	DATE	
<u>H. SUNDY S. Fierro J. ZH</u> <u>OU</u>	<u>4-14-APR</u> <u>0506/12/065/1</u> <u>5/2012</u>		
CLASSIFICATION			
<b>CONFIDENTIAL UNRESTRICTED</b>			

**TABLE 1 - CONTACT RESISTANCE**

Connector Spacing	Maximum Resistance - Milliohms	
	Initial	After Test
0.100	11	15
0.150	13	20

- 3.5.3 Low Level Circuit Resistance. (see 5.1) The low level circuit (contact) resistance shall not exceed the value specified in Table 1, when measured in accordance with MIL-STD-1344, Method 3002. The following details shall apply:
- (a) Method of Connection - See Figure 1
  - (b) Test Current - 1 milliampere DC
  - (c) Maximum Open Circuit Voltage - 20 millivolts DC
- 3.5.4 Capacitance. (see 5.3) The capacitance between adjacent positions of the unmated connector shall not exceed 2.0 pf, when measured in accordance with MIL-STD-202, Method 305. The following details shall apply:
- (a) Points of Measurement - Between adjacent contact positions
  - (b) Test Frequency - 1 megahertz
- 3.5.5 Insulation Resistance. (see 5.3) The insulation resistance between adjacent positions of the unmated connector shall be not less than 50,000 megohms (20,000 megohms after exposure to the humidity environment specified in paragraph 3.7.2), when tested in accordance with MIL-STD-202, Method 302. The following details shall apply:
- (a) Points of Measurement - Between adjacent contact positions
  - (b) Test Potential - B (500 volts)
  - (c) Time of Application - 60 seconds
- 3.5.6 Dielectric Withstanding Voltage. (see 5.3) There shall be no evidence of insulation breakdown, arc-over, or excessive (>1 milliampere) leakage current when the unmated connector is tested in accordance with MIL-STD-202, Method 301. The following details shall apply:
- (a) Test Potential – 1000 volts RMS, 60 Hz at sea-level
  - (b) Test Duration - 60 seconds
  - (c) Points of Measurement - Between adjacent contact positions

This document is the property of and embodies CONFIDENTIAL and PROPRIETARY information of FCI/FCI Electronics. No part of the information shown on this document may be used in any way without the written consent of FCI/FCI Electronics.

Form E-3005  
Rev B-07/30/04A-02/12/04  
V04-078220603

Copyright FCI

Form E-3334  
Rev E

GS-01-004

GS-01-001

	TYPE	NUMBER	
	<b>PRODUCT SPECIFICATION</b>	<b>BUS-12-023</b>	
TITLE	PAGE	REVISION	
<b>Mini-Jump – Gold or GXT Plated</b>	6 of 17	FED	
	AUTHORIZED BY	DATE	
	H: SUNDYS.FierroJ.ZH OU	4-14-APR 0506/12/065/1 5/2012	
	CLASSIFICATION		
	<b>CONFIDENTIAL UNRESTRICTED</b>		

**3.6 Mechanical Characteristics**

**3.6.1 Contact Retention.** (see 5.2) The contact pair shall not be dislodged from the housing when an axial force of 4 pounds (2 pounds per terminal) is applied in the direction opposite from that of insertion. The force shall be applied at a crosshead speed of 1 inch per minute and the maximum load shall be maintained for 10 seconds.

**3.6.2 Total Mating Force.** The total force to mate the connector with an appropriate header having properly configured (see Figure 2) 0.025 inch square pins shall not exceed the value shown in Table II for the appropriate contact spring thickness.

**TABLE II - FORCE VS. SPRING THICKNESS**

Spring Thickness (MILS)	Individual Contact Force-Grams		Total Force (Grams Max)
	Insert (Max)	Withdraw (Min)	
3.5	300	40	600
4.8	450	50	900*

\* Multiply by number of positions for multi-position assembly.

**3.6.3 Individual Contact Insertion Force.** When measured using a maximum gage configured as shown in Figure 3, the individual contact insertion force shall not exceed the value shown in Table II for the contact spring thickness used in the terminal.

**3.6.4 Individual Contact Withdrawal Force.** After three insertions of a maximum gage, the force required to withdraw a minimum gage, configured as shown in figure 3, shall be not less than the value shown in Table II for the contact spring thickness used in the terminal.

**3.6.5 Durability.** After the number of mating cycles specified in Table III, the individual contact withdrawal force shall be not less than the value shown in Table II (see 3.6.4) and the contact resistance shall not exceed the value specified in Table I (see 3.5.2).

**TABLE III - DURABILITY**

Spring Thickness (MILS)	Mating Cycles
3.5	100
4.8	50

This document is the property of and embodies CONFIDENTIAL and PROPRIETARY information of FCI/FCI Electronics. No part of the information shown on this document may be used in any way without the written consent of FCI/FCI Electronics.

Form E-3005  
Rev B-07/30/04A-02/12/04  
V04-078220603

GS-01-004

Copyright FCI

Form E-3334  
Rev E

GS-01-001

	TYPE	NUMBER	
	<b>PRODUCT SPECIFICATION</b>	<b>BUS-12-023</b>	
TITLE	PAGE	REVISION	
<u>Mini-Jump – Gold or GXT Plated</u>	7 of 17	FED	
	AUTHORIZED BY	DATE	
	<u>H:</u> <u>SUNDYS.FierroJ.ZH</u> <u>OU</u>	<u>4-14-APR</u> <u>0506/12/065/1</u> <u>5/2012</u>	
	CLASSIFICATION		
	<b>CONFIDENTIAL UNRESTRICTED</b>		

### 3.7 Environmental Conditions

3.7.1 Thermal Shock. After exposure of the mated connector to alternate periods of extreme high and low temperature, there shall be no evidence of cracking or crazing of the insulator housing or other physical damage to the connector; the dielectric withstanding voltage of the unmated connector shall be not less than 1000 volts RMS (see 3.5.6). The test shall be in accordance with MIL-STD-202, Method 107. The following details and exceptions shall apply:

- (a) Test Condition - A (5, 1-hour cycles)
- (b) Temperature Range - +120°C to -55°C
- (c) Exposure time at each temperature - 30 minutes, minimum
- (d) Transfer time - 30 seconds maximum

3.7.2 Humidity. After exposure of the mated connector to a high humidity environment, the contact resistance shall not exceed the value specified in Table I (see 3.5.2). The insulation resistance of the unmated connector shall be not less than 20,000 megohms (see paragraph 3.5.5). The test shall be in accordance with MIL-STD-202, Method 106 (excluding steps 7a and 7b). The following details shall apply:

- (a) Test Duration - 10 days (240 hours)

3.7.3 High Temperature Life. After exposure of the mated connector to a high temperature operating environment, the contact resistance shall not exceed the value specified in Table I (see 3.5.2). The insulation resistance of the unmated connector shall be not less than 50,000 megohms (see 3.5.5). The test shall be in accordance with MIL-STD-202, Method 108. The following details shall apply:

- (a) Chamber Temperature - Adjusted to achieve +120°C temperature of contact under load.
- (b) Test Condition - B (250 hours)
- (c) Operating Conditions - Rated current (see 3.5.1) through both contacts; duty cycle: 45 minutes ON and 15 minutes OFF.

This document is the property of and embodies CONFIDENTIAL and PROPRIETARY information of FCI/FCI Electronics. No part of the information shown on this document may be used in any way without the written consent of FCI/FCI Electronics.

Form E-3005  
Rev B-07/30/04A-02/12/04  
V04-078220603

GS-01-004

Copyright FCI

Form E-3334  
Rev E

GS-01-001



TYPE	<b>PRODUCT SPECIFICATION</b>	NUMBER	<b>BUS-12-023</b>
TITLE	<b>Mini-Jump – Gold or GXT Plated</b>	PAGE	8 of 17
		REVISION	<b>FED</b>
		AUTHORIZED BY	H: <u>SUNDYS.FierroJ.ZH</u> OU
		DATE	<del>4-14-APR</del> <u>0506/12/065/1</u> 5/2012
		CLASSIFICATION	<b>CONFIDENTIAL UNRESTRICTED</b>

**FIGURE 2 - MATING HEADER**

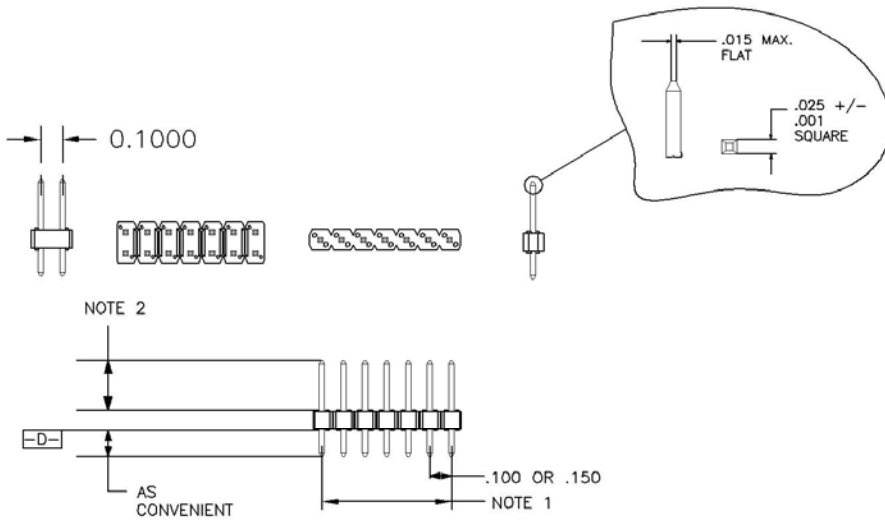

1. MEASURED AT DATUM-D-WITH PART IN RESTRAINED (FLAT) CONDITION.
2. LENGTH TO INSURE CONTACT WITH RECEPTACLE INTERFACE.
3. PLATING; 30MICROINCHES (MINIMUM) GOLD, TYPE II, GRADE C OVER 50 MICROINCHES (MINIMUM) NICKEL PER QQ-N-290, CLASS 2.

This document is the property of and embodies CONFIDENTIAL and PROPRIETARY information of FCI/FCI Electronics. No part of the information shown on this document may be used in any way without the written consent of FCI/FCI Electronics.

Form E-3005  
Rev B-07/20/04A-02/12/04  
V04-078220603

GS-01-004

Copyright FCI

Form E-3334  
Rev E

GS-01-001



	TYPE	NUMBER
	<b>PRODUCT SPECIFICATION</b>	<b>BUS-12-023</b>
TITLE	PAGE	REVISION
<b>Mini-Jump – Gold or GXT Plated</b>	9 of 17	<b>FED</b>
	AUTHORIZED BY	DATE
	H: <u>SUNDYS.FierroJ.ZH</u> OU	<del>4-14-APR</del> <u>0506/12/065/1</u> <u>5/2012</u>
	CLASSIFICATION	
	<b>CONFIDENTIAL UNRESTRICTED</b>	

**FIGURE 3 - INSERTION/WITHDRAWAL FORCE GAGE**

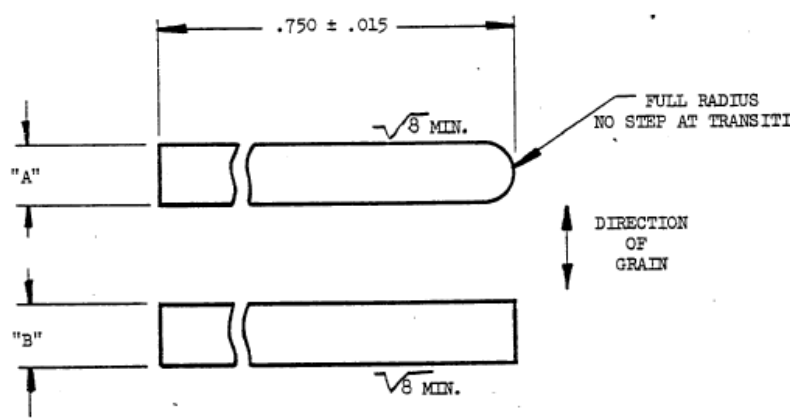

GAGE	DIMENSIONS - INCH			
	A	TOL.	B	TOL.
MIN.	.0240	+ .0000	.025	± .001
MAX.	.0260	+ .0002	.025	± .001
		- .0000		

Material: Shim stock; grind to width and break edges; do not polish working surface.

Clean gage as follows before each use:

- A. Scour surface with mildly abrasive material (rubber eraser, e.g.)
- B. Wash surface with Freon and dry with clean cotton. DO NOT TOUCH SURFACE WITH FINGERS.

This document is the property of and embodies CONFIDENTIAL and PROPRIETARY information of FCI/FCI Electronics. No part of the information shown on this document may be used in any way without the written consent of FCI/FCI Electronics.

Form E-3005  
 Rev B-07/20/04A-02/12/04  
 V04-078220603 GS-01-004

Copyright FCI  
 Form E-3334  
 Rev E GS-01-001

	TYPE	NUMBER	
	<b>PRODUCT SPECIFICATION</b>	<b>BUS-12-023</b>	
TITLE	PAGE	REVISION	
<b>Mini-Jump – Gold or GXT Plated</b>	10 of 17	<b>FED</b>	
	AUTHORIZED BY	DATE	
	<b>H. SUNDY S. Fierro J. ZH</b> <b>OU</b>	<del>4-14-APR</del> <b>0506/12/065/1</b> <b>5/2012</b>	
	CLASSIFICATION		
	<b>CONFIDENTIAL UNRESTRICTED</b>		

**FIGURE 4 - MOUNTING FOR STOCK/VIBRATION**

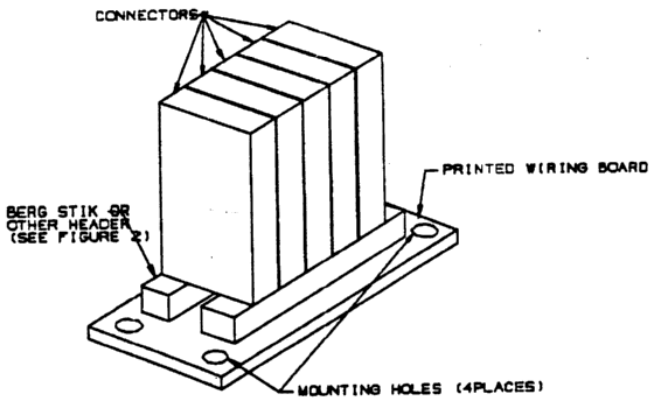

CONNECTORS STACKED ON .100 OR .150 CENTERS, AS APPROPRIATE.

This document is the property of and embodies CONFIDENTIAL and PROPRIETARY information of FCI, FCI Electronics. No part of the information shown on this document may be used in any way without the written consent of FCI, Electronics.

Form E-3005  
 Rev B-07/30/04A-02/12/04  
 V04-078220603

Copyright FCI

Form E-3334  
 Rev E

GS-01-004

GS-01-001

	TYPE	NUMBER	
	<b>PRODUCT SPECIFICATION</b>	<b>BUS-12-023</b>	
TITLE	PAGE	REVISION	
<u>Mini-Jump – Gold or GXT Plated</u>	11 of 17	FED	
	AUTHORIZED BY	DATE	
	H: <u>SUNDYS.FierroJ.ZH</u> OU	<del>4-14-APR</del> <u>0506/12/065/1</u> 5/2012	
	CLASSIFICATION		
	<b>CONFIDENTIAL UNRESTRICTED</b>		

- 3.7.4 Shock. There shall be no evidence of physical or mechanical damage when the mated connector is subjected to transient accelerations. During and after each shock, the contacts shall evidence no discontinuity greater than 1 microsecond. The test shall be in accordance with MIL-STD-202, Method 213. The following details shall apply:
- (a) Test Condition - 1 (100G, 6 ms sawtooth).
  - (b) Number of Shocks - 3 shocks in each direction along three orthogonal axes (18 total).
  - (c) Mounting - See Figure 4
  - (d) Restraining Method - None
- 3.7.5 Vibration. There shall be no evidence of physical or mechanical damage when the mated connector is subjected to prolonged mechanical vibration; and the individual contact withdrawal force shall be not less than the value specified in Table II (see 3.6.4). During the vibration along each axis, the contacts shall evidence no discontinuity greater than 1 microsecond. At the completion of the test, the contact resistance shall not exceed the value specified in Table I (see 3.5.2). The test shall be in accordance with MIL-STD-202, Method 204. The following details shall apply:
- (a) Test Condition - B (+ 15G, 10 to 2000 Hz)
  - (b) Test Duration - 4 hours along each of three orthogonal axes (12 hours total)
  - (c) Mounting - see Figure 4
  - (d) Restraining Method - None
- 3.7.6 Hydrogen Sulfide (H<sub>2</sub>S) Atmosphere. After exposure of the mated connector to moist contaminated environment, the low level circuit resistance shall not exceed the value specified in Table I (see 3.5.3). The following details shall apply:
- (a) Test Medium - 3 ppm H<sub>2</sub>S in air
  - (b) Test Temperature - +40°C
  - (c) Test Duration - 48 hours
- 3.7.7 Salt Spray. After exposure of the mated connector to a salt fog atmosphere, the low level circuit resistance shall not exceed the value specified in Table I (see 3.5.3). The test shall be in accordance with MIL-STD-202, Method 101. The following details shall apply:
- (a) Salt Solution - 5 percent by weight
  - (b) Test Condition - B (48 hours)

This document is the property of and embodies CONFIDENTIAL and PROPRIETARY information of FCI/FCI Electronics. No part of the information shown on this document may be used in any way without the written consent of FCI/FCI Electronics.

Form E-3005  
Rev B-07/20/04A-02/12/04  
V04-078220603

Copyright FCI

Form E-3334  
Rev E

GS-01-004

GS-01-001

	TYPE	NUMBER	
	<b>PRODUCT SPECIFICATION</b>	<b>BUS-12-023</b>	
TITLE	PAGE	REVISION	
<u>Mini-Jump – Gold or GXT Plated</u>	12 of 17	FED	
	AUTHORIZED BY	DATE	
	<u>H. SUNDY S. Fierro J. ZH</u> <u>OU</u>	<u>4-14-APR</u> <u>0506/12/065/1</u> <u>5/2012</u>	
	CLASSIFICATION		
	<b>CONFIDENTIAL UNRESTRICTED</b>		

**4.0 QUALITY ASSURANCE**

4.1 Equipment Calibration

All test equipment and facilities used in the performance of any test shall be maintained in a calibration system in accordance with MIL-C-45662.

4.2 Inspection Conditions

Unless otherwise specified herein, all inspections shall be performed under the following ambient conditions:

- (a) Temperature - 25°C + 5°C
- (b) Relative Humidity - 30% to 80%
- (c) Barometric Pressure - Local ambient

4.3 Qualification Inspection

Qualification inspection shall be performed on sample units produced with equipment normally used in production.

4.3.1 Sample. Qualification Inspection shall be performed on five (5) groups of connectors; each group shall comprise five (5) connectors of each type for which qualification under this specification is desired. For multi-position connectors, a sixth sample (one connector) shall be required for Group 3 tests.

4.3.2 Preparation of Samples

4.3.2.1 Printed Wiring Test Boards - Five (5) test boards conforming to the applicable requirements of MIL-P-55110 and MIL-STD-275 shall be prepared as shown in Figure 5.

4.3.2.2 Mating Headers - Five (5) mating headers of the appropriate population and configuration and conforming to the requirements of Figure 2 shall be prepared.

4.3.2.3 Header Mounting - The headers shall be installed on, and hand soldered to, the test boards; an appropriately active flux shall be used to ensure that the connection does not contribute any degradation.

This document is the property of and embodies CONFIDENTIAL and PROPRIETARY information of FCI, FCI Electronics. No part of the information shown on this document may be used in any way without the written consent of FCI, Electronics.

Form E-3005  
Rev B-07/30/04A-02/12/04  
V04-078220603 GS-01-004

Copyright FCI  
Form E-3334  
Rev E GS-01-001

	TYPE	NUMBER	
	<b>PRODUCT SPECIFICATION</b>	<b>BUS-12-023</b>	
TITLE	PAGE	REVISION	
	13 of 17	FED	
Mini-Jump – Gold or GXT Plated	AUTHORIZED BY	DATE	
	H: SUNDYS.FierroJ.ZH OU	<del>4-14-APR</del> 0506/12/065/1 5/2012	
CLASSIFICATION			
			<b>CONFIDENTIAL UNRESTRICTED</b>

4.3.2.4 Sample Configuration - When mated with the headers, the connectors shall form a series connected circuit.

4.3.3 Test Sequence. The connectors shall be subjected to the inspections specified in Table IV, in the order shown.

4.4 Regualification Testing

If either of the following conditions occur, the product responsible engineer shall initiate regualification testing.

4.4.1 A significant design change is made to an existing product previously qualified under this specification. A significant design change shall be defined to include, but not be limited to, changes in contact material composition, contact material thickness, contact force, contact surface geometry, underlying material composition, underlying material thickness, insulator design, contact base material, or contact lubrication requirements.

4.4.2 A product failure occurs during production or end use requiring corrective action to be taken relative to the product design or manufacturing process.

Regualification testing shall consist of all or applicable parts of the Qualification Test Matrix as determined by development/product, quality, test, and reliability engineering.

This document is the property of and embodies CONFIDENTIAL and PROPRIETARY information of FCI/FCI Electronics. No part of the information shown on this document may be used in any way without the written consent of FCI/FCI Electronics.

Form E-3005  
Rev B-07/20/04A-02/12/04  
V04-078220603

GS-01-004

Copyright FCI

Form E-3334  
Rev E

GS-01-001



TYPE <b>PRODUCT SPECIFICATION</b>	NUMBER <b>BUS-12-023</b>
TITLE <b>Mini-Jump – Gold or GXT Plated</b>	PAGE 14 of <b>17</b>
	REVISION <b>FED</b>
	AUTHORIZED BY <b>H. SUNDY S. Fierro J. ZH OU</b>
	DATE <b>4-14-APR 0506/12/065/1 5/2012</b>
CLASSIFICATION <b>CONFIDENTIAL UNRESTRICTED</b>	

**FIGURE 5**

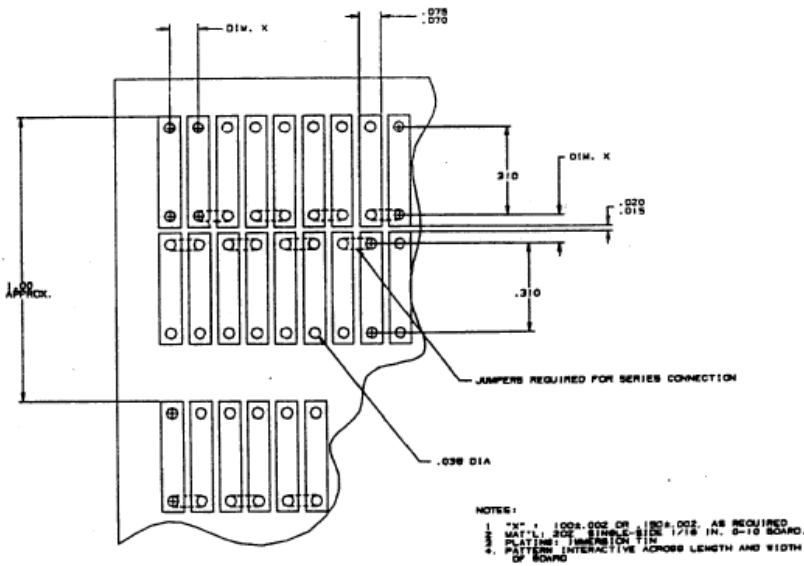

This document is the property of and embodies CONFIDENTIAL and PROPRIETARY information of FCI/FCI Electronics. No part of the information shown on this document may be used in any way without the written consent of FCI/FCI Electronics.

Form E-3005  
Rev B-07/20/04A-02/12/04  
V04-078220603

GS-01-004

Copyright FCI

Form E-3334  
Rev E

GS-01-001



	TYPE	NUMBER	
	<b>PRODUCT SPECIFICATION</b>	<b>BUS-12-023</b>	
TITLE	PAGE	REVISION	
<b>Mini-Jump – Gold or GXT Plated</b>	16 of 17	FED	
	AUTHORIZED BY	DATE	
	H: SUNDYS.FierroJ.ZH OU	4-14-APR 0506/12/065/1 5/2012	
	CLASSIFICATION		
	<b>CONFIDENTIAL UNRESTRICTED</b>		

**5.0 NOTES AND DEFINITIONS**

**5.1 Contact Resistance**

Differences in contact resistance between various terminal configurations represent changes in bulk resistance due to longer lengths of current path.

**5.2 Contact Retention**

Only terminals employing an integral latching mechanism (e.g. barbs, dimples, etc.) for rigid retention within the housing are subject to this requirement. Terminals which "free-float" within a housing and are retained by the closure of some form of hinged cover are not included.

**5.3 Multi-Position Connector**

Assemblies containing more than one jumper shall be subjected to the Group 3 tests; these tests do not apply to single position devices.

Formatted: French (France)

This document is the property of and embodies CONFIDENTIAL and PROPRIETARY information of FCI, FCI Electronics. No part of the information shown on this document may be used in any way without the written consent of FCI, Electronics.

Form E-3005  
Rev B-07/30/04A-02/12/04  
V04-078220603

Copyright FCI

Form E-3334  
Rev E

GS-01-004

GS-01-001





TYPE <b>PRODUCT SPECIFICATION</b>	NUMBER <b>BUS-12-023</b>
TITLE <b>Mini-Jump – Gold or GXT Plated</b>	PAGE 17 of 17
	REVISION <b>FED</b>
	AUTHORIZED BY <b>H: SUNDYS.FierroJ.ZH OU</b>
	DATE <b>4-14-APR 0506/12/065/1 5/2012</b>
CLASSIFICATION <b>CONFIDENTIAL UNRESTRICTED</b>	

**REVISION RECORD**

REV	PAGE	DESCRIPTION	EC #	DATE
A	1	Change the Au plating of the spring to 3u"	10071	11/11/83
B	15	Replaced section 4.4 and subsections;	V10413	02/27/91
	17	Deleted Table V - Quality Inspection;		
	18	Deleted Table VI - Acceptance Inspection		
C	All	Revised format to be consistent with GS-01-001, and change BERG, Dupont, etc. references to FCI.	V01904	07/28/00
D	All	Revised the Format and changed section 3.5.6 and 3.71 to 1000 Vrms.	- -V05-0355	04-15-05
E	1	Add lead free information	M06-0228	06/12/06
F	1,2	Change plating from Au to Au or gold flash over	ELX-N-011638	05/15/12

**palladium alloy The following constitutes the recommended order and paragraph numbering scheme in compliance with GS-01-001. Paragraphs that are not needed shall be eliminated, and subsequent paragraphs renumbered. Please delete this note after reading.**

OBJECTIVE

SCOPE

GENERAL

DEFINITIONS

PROCEDURE

REFERENCE DOCUMENTS (If Applicable)

- Formatted: Bullets and Numbering
- Formatted: Bullets and Numbering
- Formatted: Indent: First line: 11 ch
- Formatted: Indent: First line: 11 ch
- Formatted: Indent: Left: 0", First line: 11 ch
- Formatted: Bullets and Numbering
- Formatted: Indent: First line: 11 ch
- Formatted: Indent: Left: 0", First line: 11 ch
- Formatted: Bullets and Numbering
- Formatted: Indent: First line: 11 ch
- Formatted: Indent: Left: 0", First line: 11 ch
- Formatted: Bullets and Numbering
- Formatted: Indent: First line: 11 ch
- Formatted: Indent: Left: 0", First line: 11 ch
- Formatted: Bullets and Numbering
- Formatted: Indent: First line: 11 ch
- Formatted: Indent: Left: 0", First line: 11 ch
- Formatted: Bullets and Numbering
- Formatted: Indent: First line: 11 ch

This document is the property of and embodies CONFIDENTIAL and PROPRIETARY information of FCI/FCI Electronics. No part of the information shown on this document may be used in any way without the written consent of FCI/FCI Electronics.

Form E-3005  
Rev B-07/20/04A-02/12/04  
V04-078220603

GS-01-004

Copyright FCI

Form E-3334  
Rev E

GS-01-001



TYPE <b>PRODUCT SPECIFICATION</b>	NUMBER <b>BUS-12-023</b>	
TITLE <b>Mini-Jump – Gold or GXT Plated</b>	PAGE 18 of 17	REVISION <b>FED</b>
	AUTHORIZED BY H: <u>SUNDYS.FierroJ.ZH</u> OU	DATE <del>4-14-APR</del> <u>0506/12/065/1</u> 5/2012
CLASSIFICATION <b>CONFIDENTIAL UNRESTRICTED</b>		

NOTES (Optional)

RECORD RETENTION (If Applicable)

**The following constitutes the recommended order and paragraph numbering scheme in compliance with GS-01-001. Paragraphs that are not needed shall be eliminated, and subsequent paragraphs renumbered. Please delete this note after reading.**

OBJECTIVE

SCOPE

GENERAL

DEFINITIONS

PROCEDURE

REFERENCE DOCUMENTS (If Applicable)

NOTES (Optional)

RECORD RETENTION (If Applicable)

**The following constitutes the recommended order and paragraph numbering scheme in compliance with GS-01-001. Paragraphs that are not needed shall be eliminated, and subsequent paragraphs renumbered. Please delete this note after reading.**

1.0OBJECTIVE

- Formatted ... [1]
- Formatted: Bullets and Numbering ... [2]
- Formatted ... [3]
- Formatted ... [4]
- Formatted: Bullets and Numbering ... [5]
- Formatted ... [6]
- Formatted ... [7]
- Formatted ... [8]
- Formatted: Bullets and Numbering ... [9]
- Formatted ... [10]
- Formatted ... [11]
- Formatted: Bullets and Numbering ... [12]
- Formatted ... [13]
- Formatted ... [14]
- Formatted: Bullets and Numbering ... [15]
- Formatted ... [16]
- Formatted ... [17]
- Formatted: Bullets and Numbering ... [18]
- Formatted ... [19]
- Formatted ... [20]
- Formatted: Bullets and Numbering ... [21]
- Formatted ... [22]
- Formatted ... [23]
- Formatted: Bullets and Numbering ... [24]
- Formatted ... [25]
- Formatted ... [26]
- Formatted: Bullets and Numbering ... [27]
- Formatted ... [28]
- Formatted ... [29]
- Formatted: Bullets and Numbering ... [30]
- Formatted ... [31]
- Formatted ... [32]
- Formatted ... [33]
- Formatted: Bullets and Numbering ... [34]

This document is the property of and embodies CONFIDENTIAL and PROPRIETARY information of FCI/FCI Electronics. No part of the information shown on this document may be used in any way without the written consent of FCI/FCI Electronics.

Form E-3005  
Rev B-07/30/04A-02/12/04  
V04-078220603

GS-01-001

Copyright FCI

Form E-3334  
Rev E

GS-01-001



TYPE <b>PRODUCT SPECIFICATION</b>	NUMBER <b>BUS-12-023</b>	
TITLE <b>Mini-Jump – Gold or GXT Plated</b>	PAGE 19 of 17	REVISION <b>FED</b>
	AUTHORIZED BY <b>H: SUNDYS.FierroJ.ZH OU</b>	DATE <del>4-14-APR</del> <b>0506/12/065/1 5/2012</b>
CLASSIFICATION <b>CONFIDENTIAL UNRESTRICTED</b>		

2.0 SCOPE

Formatted: Bullets and Numbering

3.0 GENERAL

Formatted: Bullets and Numbering

4.0 DEFINITIONS

Formatted: Bullets and Numbering

5.0 PROCEDURE

Formatted: Bullets and Numbering

6.0 REFERENCE DOCUMENTS (If Applicable)

Formatted: Bullets and Numbering

7.0 NOTES (Optional)

Formatted: Bullets and Numbering

8.0 RECORD RETENTION (If Applicable)

Formatted: Bullets and Numbering

This document is the property of and embodies CONFIDENTIAL and PROPRIETARY information of FCI, FCI Electronics. No part of the information shown on this document may be used in any way without the written consent of FCI, Electronics.

Form E-3005  
Rev B-07/30/04A-02/12/04  
V04-078220603

GS-01-004

Copyright FCI

Form E-3334  
Rev E

GS-01-001

Page 18: [1] Formatted pdselxadmin2 5/16/2012 7:01:00 AM

Indent: Left: 0", First line: 11 ch

Page 18: [2] Change lkline 4/26/2001 7:20:00 AM

Formatted Bullets and Numbering

Page 18: [3] Formatted zhoujan 5/4/2012 1:49:00 PM

Indent: First line: 11 ch

Page 18: [4] Formatted pdselxadmin2 5/16/2012 7:01:00 AM

Indent: Left: 0", First line: 11 ch

Page 18: [5] Change lkline 4/26/2001 7:20:00 AM

Formatted Bullets and Numbering

Page 18: [6] Formatted pdselxadmin2 5/16/2012 7:01:00 AM

Indent: First line: 11 ch

Page 18: [7] Formatted zhoujan 5/4/2012 1:49:00 PM

Indent: First line: 11 ch

Page 18: [8] Formatted pdselxadmin2 5/16/2012 7:01:00 AM

Indent: Left: 0", First line: 11 ch

Page 18: [9] Change Irene T Myers 5/18/2001 2:17:00 PM

Formatted Bullets and Numbering

Page 18: [10] Formatted zhoujan 5/4/2012 1:49:00 PM

Indent: First line: 11 ch

Page 18: [11] Formatted pdselxadmin2 5/16/2012 7:01:00 AM

Indent: Left: 0", First line: 11 ch

Page 18: [12] Change Irene T Myers 5/18/2001 2:17:00 PM

Formatted Bullets and Numbering

Page 18: [13] Formatted zhoujan 5/4/2012 1:49:00 PM

Indent: First line: 11 ch

Page 18: [14] Formatted pdselxadmin2 5/16/2012 7:01:00 AM

Indent: Left: 0", First line: 11 ch

Page 18: [15] Change Irene T Myers 5/18/2001 2:17:00 PM

Formatted Bullets and Numbering

Page 18: [16] Formatted zhoujan 5/4/2012 1:49:00 PM

Indent: First line: 11 ch

Page 18: [17] Formatted pdselxadmin2 5/16/2012 7:01:00 AM

Indent: Left: 0", First line: 11 ch

Page 18: [18] Change Irene T Myers 5/18/2001 2:17:00 PM

Formatted Bullets and Numbering

Page 18: [19] Formatted zhoujan 5/4/2012 1:49:00 PM

Indent: First line: 11 ch

Page 18: [20] Formatted pdselxadmin2 5/16/2012 7:01:00 AM

Indent: Left: 0", First line: 11 ch

Page 18: [22] Formatted	zhoujan	5/4/2012 1:49:00 PM
Indent: First line: 11 ch		
Page 18: [23] Formatted	pdselexadmin2	5/16/2012 7:01:00 AM
Indent: Left: 0", First line: 11 ch		
Page 18: [24] Change	Irene T Myers	5/18/2001 2:17:00 PM
Formatted Bullets and Numbering		
Page 18: [25] Formatted	zhoujan	5/4/2012 1:49:00 PM
Indent: First line: 11 ch		
Page 18: [26] Formatted	pdselexadmin2	5/16/2012 7:01:00 AM
Indent: Left: 0", First line: 11 ch		
Page 18: [27] Change	Irene T Myers	5/18/2001 2:17:00 PM
Formatted Bullets and Numbering		
Page 18: [28] Formatted	zhoujan	5/4/2012 1:49:00 PM
Indent: First line: 11 ch		
Page 18: [29] Formatted	pdselexadmin2	5/16/2012 7:01:00 AM
Indent: Left: 0", First line: 11 ch		
Page 18: [30] Change	Irene T Myers	5/18/2001 2:17:00 PM
Formatted Bullets and Numbering		
Page 18: [31] Formatted	zhoujan	5/4/2012 1:49:00 PM
Indent: First line: 11 ch		
Page 18: [32] Formatted	pdselexadmin2	5/16/2012 7:01:00 AM
Indent: First line: 11 ch		
Page 18: [33] Formatted	zhoujan	5/4/2012 1:49:00 PM
Indent: First line: 11 ch		
Page 18: [34] Change	lkline	4/18/2001 10:09:00 AM
Formatted Bullets and Numbering		

# Mouser Electronics

Authorized Distributor

Click to View Pricing, Inventory, Delivery & Lifecycle Information:

[FCI:](#)

[65474-001LF](#) [65771-002LF](#) [65474-010](#) [65474-001](#) [65474-006LF](#) [65474-007LF](#) [65771-004LF](#) [65474-010LF](#)  
[65474-002LF](#) [65474-004LF](#) [65771-001LF](#) [65771-005LF](#) [65474-005LF](#) [65771-005](#) [65771-001](#)