



Resonant-Mode Power Supply Controllers

FEATURES

- Controls Zero Current Switched (ZCS) or Zero Voltage Switched (ZVS) Quasi-Resonant Converters
- Zero-Crossing Terminated One-Shot Timer
- Precision 1%, Soft-Started 5V Reference
- Programmable Restart Delay Following Fault
- Voltage-Controlled Oscillator (VCO) with Programmable Minimum and Maximum Frequencies from 10kHz to 1MHz
- Low Start-Up Current (150µA typical)
- Dual 1 Amp Peak FET Drivers
- UVLO Option for Off-Line or DC/DC Applications

DESCRIPTION

The UC1861-1868 family of ICs is optimized for the control of Zero Current Switched and Zero Voltage Switched quasi-resonant converters. Differences between members of this device family result from the various combinations of UVLO thresholds and output options. Additionally, the one-shot pulse steering logic is configured to program either on-time for ZCS systems (UC1865-1868), or off-time for ZVS applications (UC1861-1864).

The primary control blocks implemented include an error amplifier to compensate the overall system loop and to drive a voltage controlled oscillator (VCO), featuring programmable minimum and maximum frequencies. Triggered by the VCO, the one-shot generates pulses of a programmed maximum width, which can be modulated by the Zero Detection comparator. This circuit facilitates “true” zero current or voltage switching over various line, load, and temperature changes, and is also able to accommodate the resonant components' initial tolerances.

Under-Voltage Lockout is incorporated to facilitate safe starts upon power-up. The supply current during the under-voltage lockout period is typically less than 150µA, and the outputs are actively forced to the low state. **(continued)**

Device	1861	1862	1863	1864	1865	1866	1867	1868
UVLO	16.5/10.5	16.5/10.5	36014	36014	16.5/10.5	16.5/10.5	36014	36014
Outputs	Alternating	Parallel	Alternating	Parallel	Alternating	Parallel	Alternating	Parallel
“Fixed”	Off Time	Off Time	Off Time	Off Time	On Time	On Time	On Time	On Time

BLOCK DIAGRAM

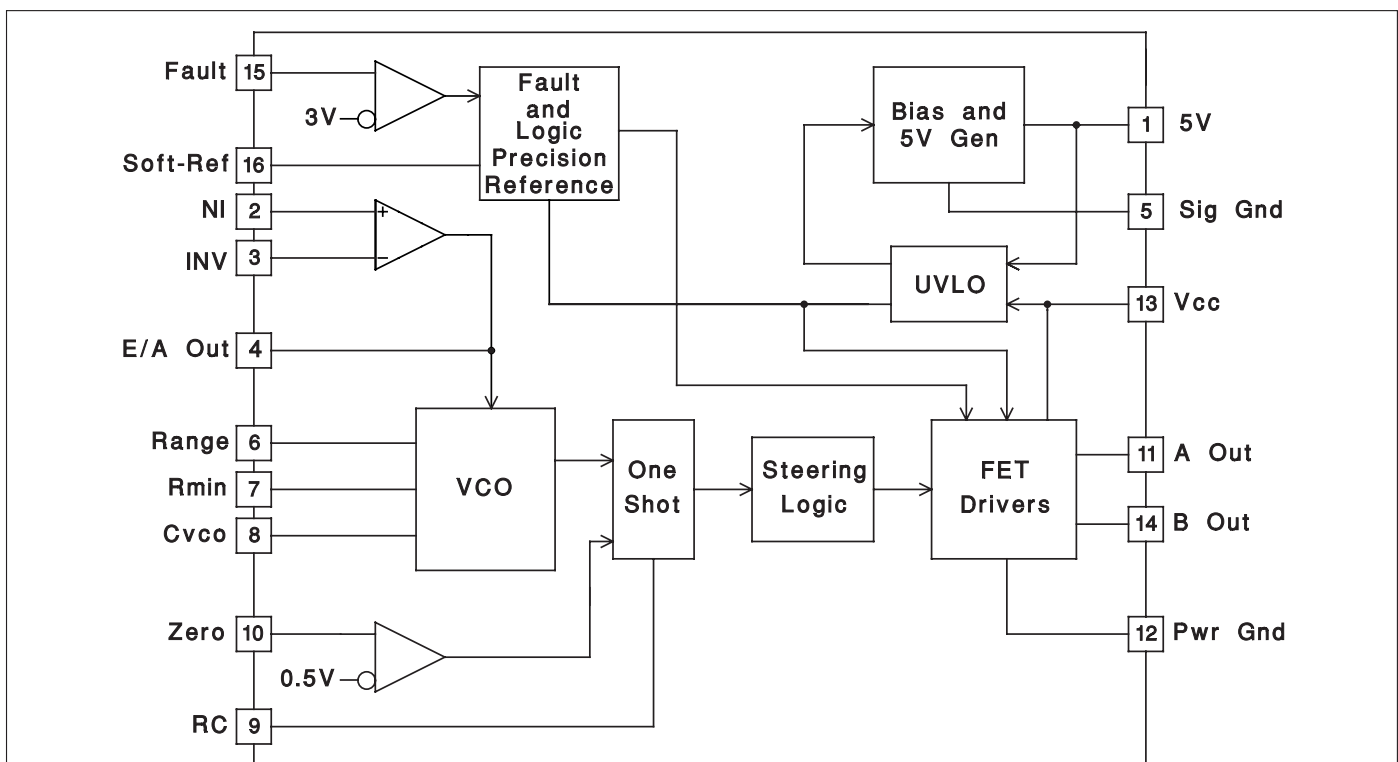

Pin numbers refer to the J and N packages.

UDG-92018

DESCRIPTION (cont.)

UVLO thresholds for the UC1861/62/65/66 are 16.5V (ON) and 10.5V (OFF), whereas the UC1863/64/67/68 thresholds are 8V (ON) and 7V (OFF). After V_{CC} exceeds the UVLO threshold, a 5V generator is enabled which provides bias for the internal circuits and up to 10mA for external usage.

A Fault comparator serves to detect fault conditions and set a latch while forcing the output drivers low. The Soft-Ref pin serves three functions: providing soft start, re-

start delay, and the internal system reference.

Each device features dual 1 Amp peak totem pole output drivers for direct interface to power MOSFETS. The outputs are programmed to alternate in the UC1861/63/65/67 devices. The UC1862/64/66/68 outputs operate in unison allowing a 2 Amp peak current.

ABSOLUTE MAXIMUM RATINGS

V_{CC}	22V
Output Current	
Source or Sink (Pins 11 & 14)	0.5A
DC Pulse (0.5 μ s)	1.5A
Power Ground Voltage	$\pm 0.2V$
Inputs (Pins 2, 3, 10, & 15)	-0.4 to 7V
Error Amp Output Current	$\pm 2mA$
Power Dissipation	1W
Junction Temperature (Operating)	150°C
Lead Temperature (Soldering, 10 seconds)	300°C

All voltages are with respect to signal ground and all currents are positive into the specified terminal. Pin numbers refer to the J and N packages. Consult Unitrode Integrated Circuits databook for information regarding thermal specifications and limitations of packages.

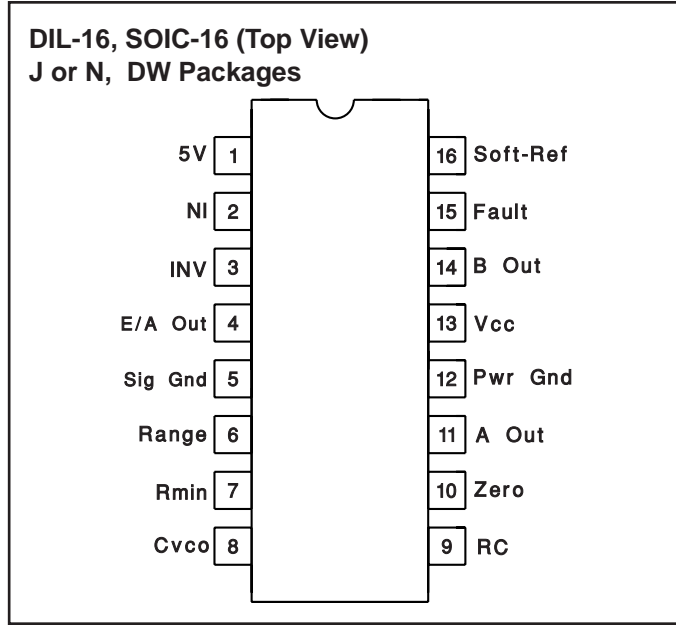

CONNECTION DIAGRAMS

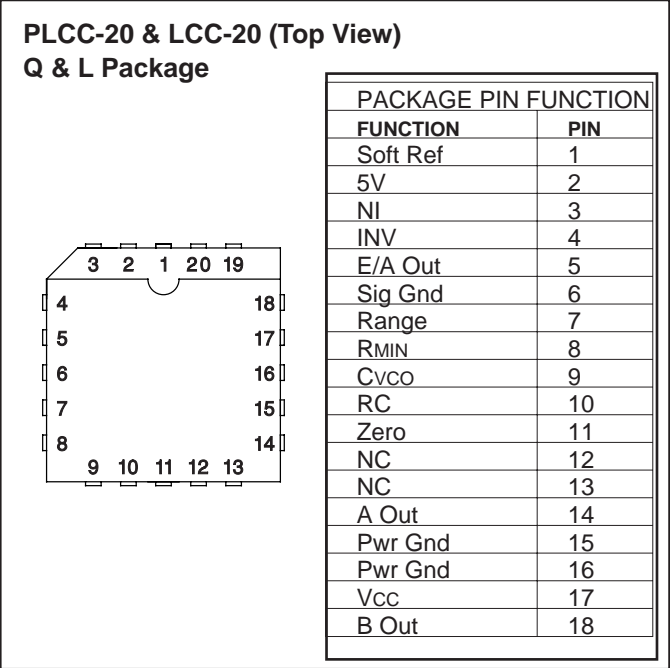

ELECTRICAL CHARACTERISTICS Unless otherwise stated, all specifications apply for $-55^{\circ}\text{C} \leq \text{T}_A \leq 125^{\circ}\text{C}$ for the UC186x, $-25^{\circ}\text{C} \leq \text{T}_A \leq 85^{\circ}\text{C}$ for the UC286x, and $0^{\circ}\text{C} \leq \text{T}_A \leq 70^{\circ}\text{C}$ for the UC386x, $V_{\text{CC}}=12\text{V}$, $C_{\text{VCO}}=1\text{nF}$, $\text{Range}=7.15\text{k}$, $R_{\text{MIN}}=86.6\text{k}$, $C=200\text{pF}$, $R=4.02\text{k}$, and $C_{\text{sr}}=0.1\mu\text{F}$. $\text{T}_A=\text{T}_J$.

PARAMETER	TEST CONDITIONS	MIN	TYP	MAX	UNITS
5V Generator					
Output Voltage	$12\text{V} \leq V_{\text{CC}} \leq 20\text{V}$, $-10\text{mA} \leq I_{\text{O}} \leq 0\text{mA}$	4.8	5.0	5.2	V
Short Circuit Current	$V_{\text{O}} = 0\text{V}$	-150		-15	mA
Soft-Reference					
Restart Delay Current	$V = 2\text{V}$	10	20	35	μA
Soft Start Current	$V = 2\text{V}$	-650	-500	-350	μA
Reference Voltage	$\text{T}_J = 25^{\circ}\text{C}$, $I_{\text{O}} = 0\text{A}$	4.95	5.00	5.05	V
	$12\text{V} \leq V_{\text{CC}} \leq 20\text{V}$, $-200\mu\text{A} \leq I_{\text{O}} \leq 200\mu\text{A}$	4.85		5.15	V
Line Regulation	$12\text{V} \leq V_{\text{CC}} \leq 20\text{V}$		2	20	mV
Load Regulation	$-200\mu\text{A} \leq I_{\text{O}} \leq 200\mu\text{A}$		10	30	mV
Error Amplifier (Note 3)					
Input Offset Voltage	$V_{\text{CM}} = 5\text{V}$, $V_{\text{O}} = 2\text{V}$, $I_{\text{O}} = 0\text{A}$	-10		10	mV
Input Bias Current	$V_{\text{CM}} = 0\text{V}$	-2.0	-0.3		μA
Voltage Gain	$V_{\text{cm}} = 5\text{V}$, $0.5\text{V} \leq V_{\text{O}} \leq 3.7\text{V}$, $I_{\text{O}} = 0\text{A}$	70	100		dB
Power Supply Rejection Ratio	$V_{\text{cm}} = 5\text{V}$, $V_{\text{O}} = 2\text{V}$, $12\text{V} \leq V_{\text{CC}} \leq 20\text{V}$	70	100		dB
Error Amplifier (Note 3) (cont.)					
Common Mode Rejection Ratio	$0\text{V} \leq V_{\text{cm}} \leq 6\text{V}$, $V_{\text{O}} = 2\text{V}$	65	100		dB
V _{OUT} Low	$V_{\text{ID}} = -100\text{mV}$, $I_{\text{O}} = 200\mu\text{A}$		0.17	0.25	V
V _{OUT} High	$V_{\text{ID}} = 100\text{mV}$, $I_{\text{O}} = -200\mu\text{A}$	3.9	4.2		V
Unity Gain Bandwidth	(Note 4)	0.5	0.8		MHz
Voltage Controlled Oscillator					
Maximum Frequency	$V_{\text{ID}} (\text{Error Amp}) = 100\text{mV}$, $\text{T}_J = 25^{\circ}\text{C}$	450	500	550	kHz
	$V_{\text{ID}} (\text{Error Amp}) = 100\text{mV}$	425		575	kHz
Minimum Frequency	$V_{\text{ID}} (\text{Error Amp}) = -100\text{mV}$, $\text{T}_J = 25^{\circ}\text{C}$	45	50	55	kHz
	$V_{\text{ID}} (\text{Error Amp}) = -100\text{mV}$	42		58	kHz
One Shot					
Zero Comparator V _{th}		0.45	0.50	0.55	V
Propagation Delay	(Note 4)		120	200	ns
Maximum Pulse Width	$V_{\text{ZERO}} = 1\text{V}$	850	1000	1150	ns
Maximum to Minimum Pulse Width Ratio	$V_{\text{ZERO}} = 0\text{V}$ UCx861 – UCx864	2.5	4	5.5	
	$V_{\text{ZERO}} = 0\text{V}$ UCx865 – UCx868. -55°C to $+85^{\circ}\text{C}$	4	5.5	7	
	$V_{\text{ZERO}} = 0\text{V}$ UCx865 – UCx868, $+125^{\circ}\text{C}$	3.8	5.5	7	
Output Stage					
Rise and Fall Time	$C_{\text{LOAD}} = 1\text{nF}$ (Note 4)		25	45	ns
Output Low Saturation	$I_{\text{O}} = 20\text{mA}$		0.2	0.5	V
	$I_{\text{O}} = 200\text{mA}$		0.5	2.2	V
Output High Saturation	$I_{\text{O}} = -200\text{mA}$, down from V_{CC}		1.7	2.5	V
UVLO Low Saturation	$I_{\text{O}} = 20\text{mA}$		0.8	1.5	V
Fault Comparator					
Fault Comparator V _{th}		2.85	3.00	3.15	V
Delay to Output	(Note 4) (Note 5)		100	200	ns

ELECTRICAL CHARACTERISTICS Unless otherwise stated, all specifications apply for $-55^{\circ}\text{C} \leq \text{TA} \leq 125^{\circ}\text{C}$ for the UC186x, $-25^{\circ}\text{C} \leq \text{TA} \leq 85^{\circ}\text{C}$ for the UC286x, and $0^{\circ}\text{C} \leq \text{TA} \leq 70^{\circ}\text{C}$ for the UC386x, $\text{Vcc}=12\text{V}$, $\text{Cvco}=1\text{nF}$, $\text{Range}=7.15\text{k}$, $\text{RMIN}=86.6\text{k}$, $\text{C}=200\text{pF}$, $\text{R}=4.02\text{k}$, and $\text{Csr}=0.1\mu\text{F}$. $\text{TA}=\text{TJ}$.

PARAMETER	TEST CONDITIONS	MIN	TYP	MAX	UNITS
UVLO					
Vcc Turn-on Threshold	UCx861, UCx862, UCx865, UCx866	15	16.5	18	V
	UCx863, UCx864, UCx867, UCx868	7	8.0	9	V
Vcc Turn-off Threshold	UCx861, UCx862, UCx865, UCx866	9.5	10.5	11.5	V
	UCx863, UCx864, UCx867, UCx868	6	7.0	8	V
Icc Start	$\text{Vcc} = \text{Vcc}(\text{on}) - 0.3\text{V}$		150	300	μA
Icc Run	$\text{VID} = 100\text{mV}$		25	32	mA

Note 1: Currents are defined as positive into the pin.

Note 2: Pulse measurement techniques are used to insure that $\text{TJ} = \text{TA}$.

Note 3: $\text{VID} = \text{V}(\text{NI}) - \text{V}(\text{INV})$.

Note 4: This parameter is not 100% tested in production but guaranteed by design.

Note 5: $\text{Vi} = 0$ to 4V $\text{tr}(\text{Vi}) = 10\text{ns}$ $\text{tpd} = t(\text{Vo} = 6\text{V}) - t(\text{Vi} = 3\text{V})$

APPLICATION INFORMATION

UVLO & 5V GENERATOR (See Figure 1): When power is applied to the chip and Vcc is less than the upper UVLO threshold, Icc will be less than $300\mu\text{A}$, the 5V generator will be off, and the outputs will be actively held low.

When Vcc exceeds the upper UVLO threshold, the 5V generator turns on. Until the 5V pin exceeds 4.9V , the outputs will still remain low.

The 5V pin should be bypassed to signal ground with a $0.1\mu\text{F}$ capacitor. The capacitor should have low equivalent series resistance and inductance.

FAULT AND SOFT-REFERENCE (See Figure 1): The Soft-Ref pin serves three functions: system reference, restart delay, and soft-start. Designed to source or sink $200\mu\text{A}$, this pin should be used as the input reference for the error amplifier circuit. This pin requires a bypass capacitor of at least $0.1\mu\text{F}$. This yields a minimum soft-start time of 1ms .

Under-Voltage Lockout sets both the fault and restart delay latches. This holds the outputs low and discharges the Soft-Ref pin. After UVLO, the fault latch is reset by the low voltage on the Soft-Ref pin. The reset fault latch resets the delay latch and Soft-Ref charges via the 0.5mA current source.

The fault pin is input to a high speed comparator with a threshold of 3V . In the event of a detected fault, the fault latch is set and the outputs are driven low. If Soft-Ref is above 4V , the delay latch is set. Restart delay is timed as Soft-Ref is discharged by $20\mu\text{A}$. When Soft-Ref is fully discharged, the fault latch is reset if the fault input signal is low. The Fault pin can be used as a system shutdown pin.

If a fault is detected during soft-start, the fault latch is set and the outputs are driven low. The delay latch will remain reset until Soft-Ref charges to 4V . This sets the delay latch, and restart delay is timed. Note that restart delay for a single fault event is longer than for recurring faults since Soft-Ref must be discharged from 5V instead of 4V .

The restart delay to soft-start time ratio is 24:1 for a fault occurring during normal operation and 19:1 for faults occurring during soft-start. Shorter ratios can be programmed down to a limit of approximately 3:1 by the addition of a $20\text{k}\Omega$ or larger resistor from Soft-Ref to ground.

A $100\text{k}\Omega$ resistor from Soft-Ref to 5V will have the effect of permanent shut down after a fault since the internal $20\mu\text{A}$ current source can't pull Soft-Ref low. This feature can be used to require recycling Vcc after a fault. Care must be taken to insure Soft-Ref is indeed low at start up, or the fault latch will never be reset.

APPLICATION INFORMATION

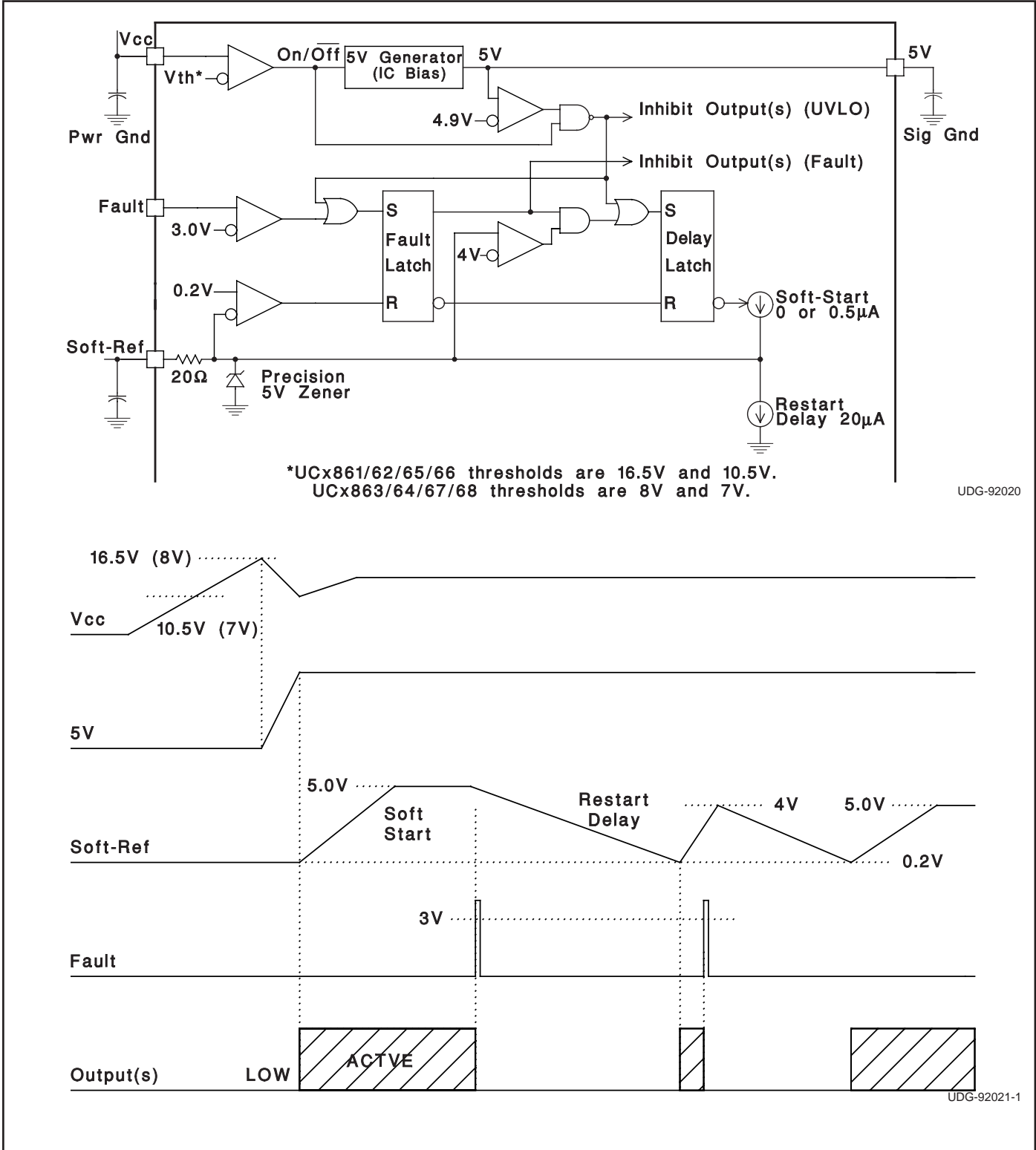
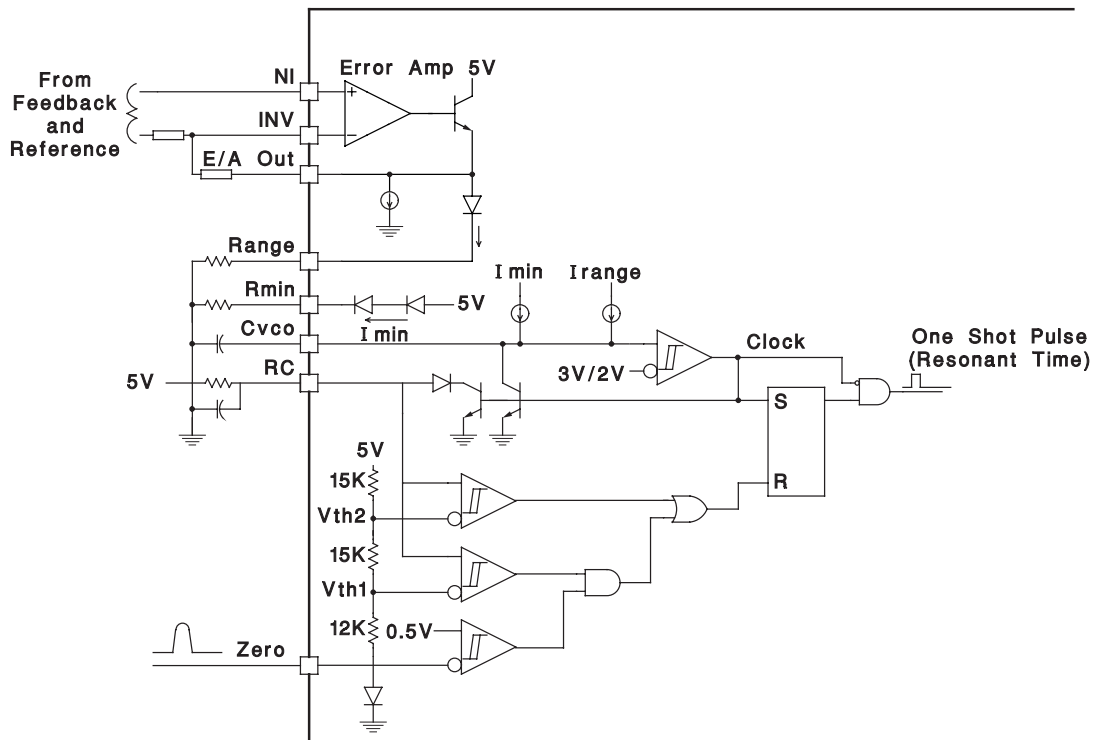
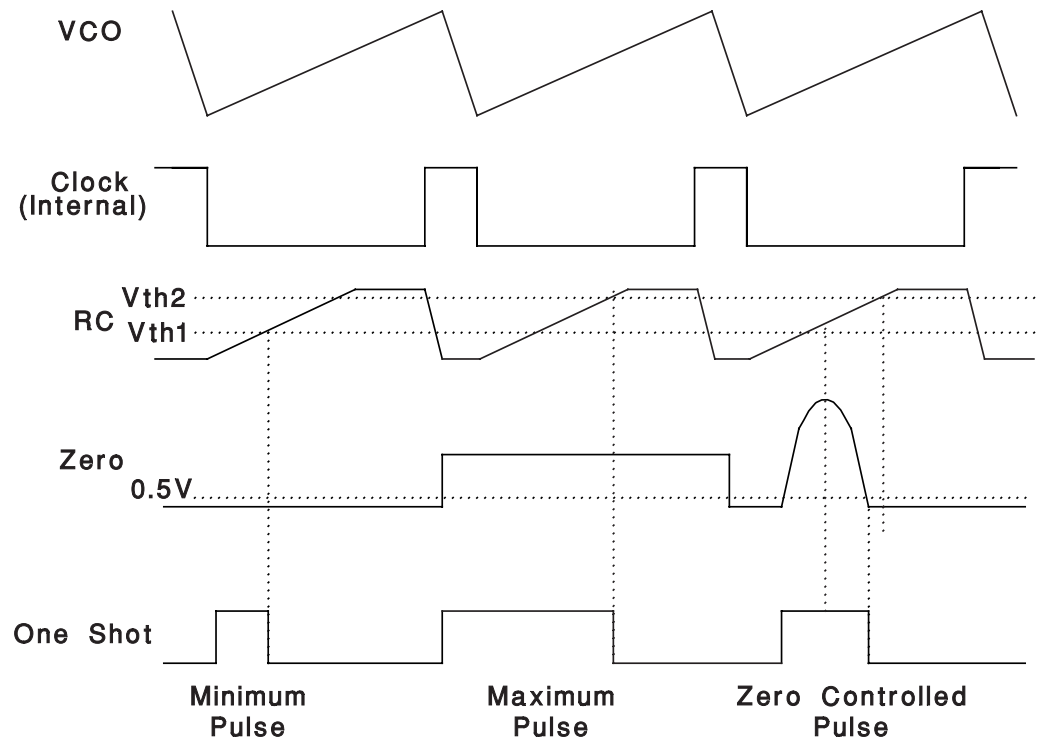

Figure 1. UVLO, 5V, fault and soft-ref.



UDG-92022-1



UDG-92023-1

Figure 2. Error Amp, Voltage Controlled Oscillator, and One Shot

APPLICATION INFORMATION

Minimum oscillator frequency is set by Rmin and Cvco. The minimum frequency is approximately given by the equation:

$$F_{MIN} \cong \frac{4.3}{R_{MIN} \cdot C_{VCO}}$$

Maximum oscillator frequency is set by Rmin, Range & Cvco. The maximum frequency is approximately given by the equation:

$$F_{MAX} \cong \frac{3.3}{(R_{MIN} // Range) \cdot C_{VCO}}$$

The Error Amplifier directly controls the oscillator frequency. E/A output low corresponds to minimum frequency and output high corresponds to maximum frequency. At the end of each oscillator cycle, the RC pin is discharged to one diode drop above ground. At the beginning of the oscillator cycle, V(RC) is less than Vth1 and so the output of the zero detect comparator is ignored. After V(RC) exceeds Vth1, the one shot pulse will be terminated as soon as the zero pin falls below 0.5V or V(RC) exceeds Vth2. The minimum one shot pulse width is approximately given by the equation:

$$Tpw(min) \ 0.3 \ R \ C.$$

The maximum pulse width is approximately given by:

$$Tpw(max) \ 1.2 \ R \ C.$$

STEERING LOGIC

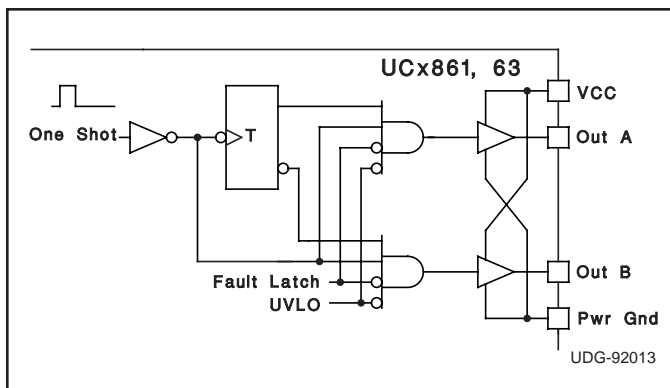

The steering logic is configured on the UC1861,63 to result in dual non-overlapping square waves at outputs A & B. This is suited to drive dual switch ZVS systems.

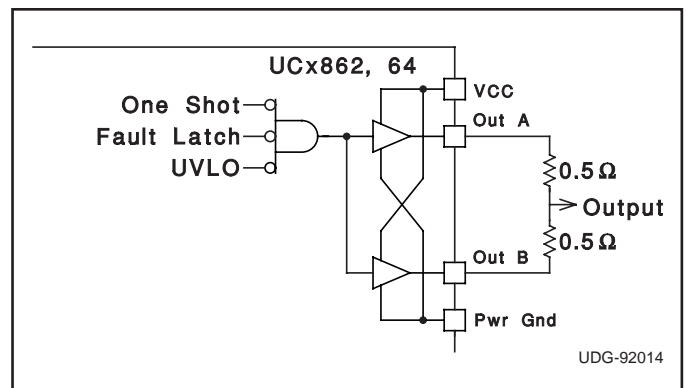

The steering logic is configured on the UC1862,64 to result in inverted pulse trains occurring identically at both output pins. This is suited to drive single switch ZVS systems. Both outputs are available to drive the same MOSFET gate. It is advisable to join the pins with 0.5 ohm resistors.

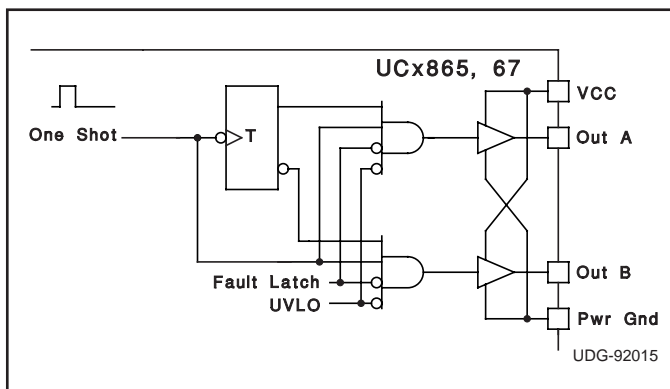

The steering logic is configured on the UC1865,67 to result in alternating pulse trains at outputs A & B. This is suited to drive dual switch ZCS systems.

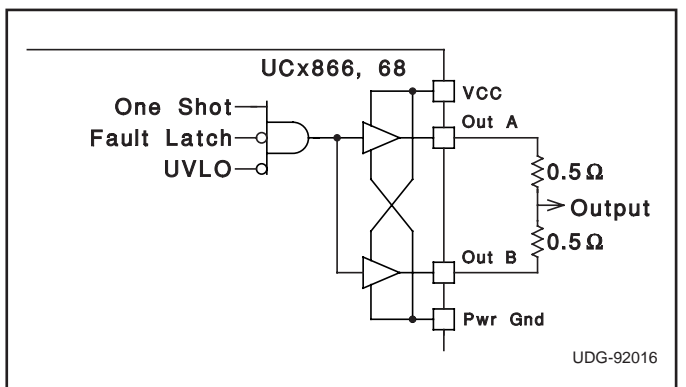

The steering logic is configured on the UC1866,68 to result in non-inverted pulse trains occurring identically at both output pins. This is suited to drive single switch ZCS systems. Both outputs are available to drive the same MOSFET gate. It is advisable to join the pins with 0.5 ohm resistors.

APPLICATION INFORMATION (cont.)

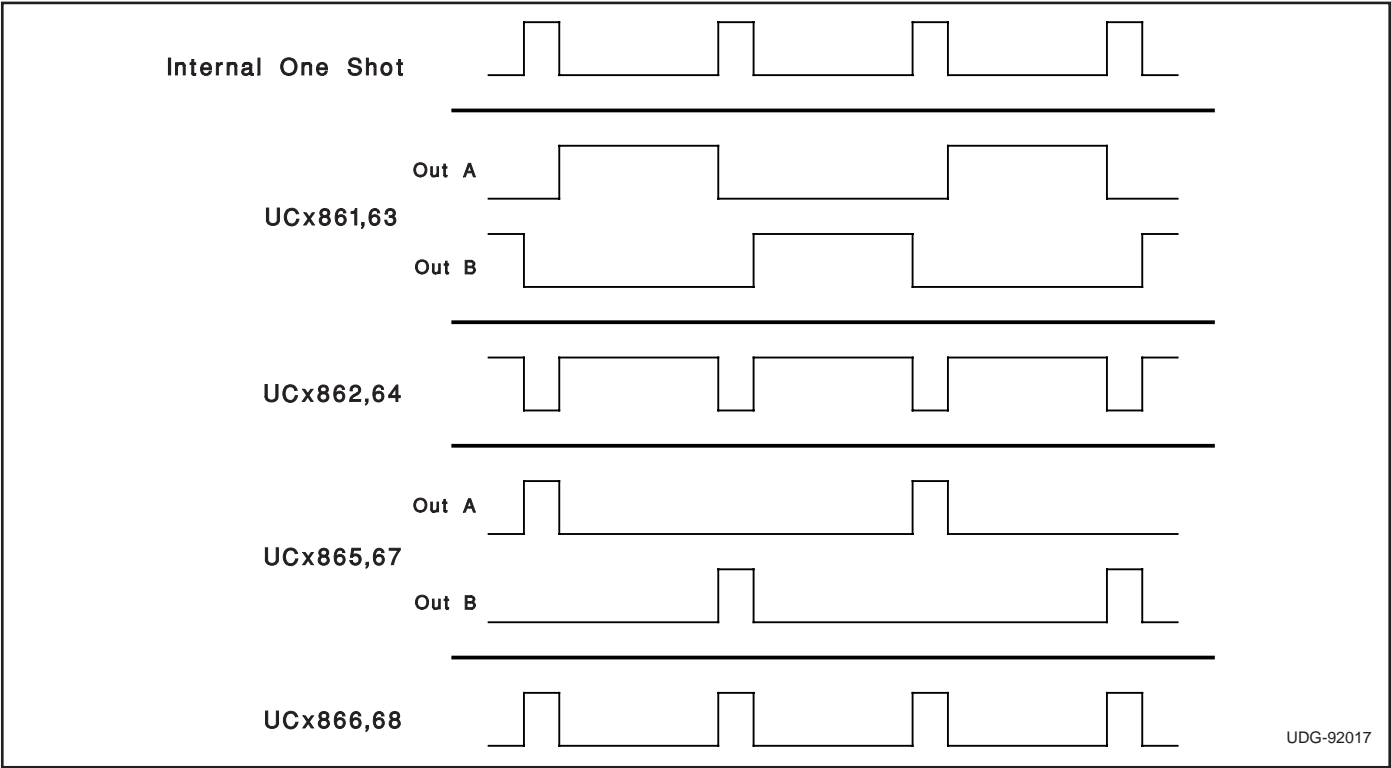

Figure 3. Current waveforms.

IMPORTANT NOTICE

Texas Instruments and its subsidiaries (TI) reserve the right to make changes to their products or to discontinue any product or service without notice, and advise customers to obtain the latest version of relevant information to verify, before placing orders, that information being relied on is current and complete. All products are sold subject to the terms and conditions of sale supplied at the time of order acknowledgement, including those pertaining to warranty, patent infringement, and limitation of liability.

TI warrants performance of its semiconductor products to the specifications applicable at the time of sale in accordance with TI's standard warranty. Testing and other quality control techniques are utilized to the extent TI deems necessary to support this warranty. Specific testing of all parameters of each device is not necessarily performed, except those mandated by government requirements.

CERTAIN APPLICATIONS USING SEMICONDUCTOR PRODUCTS MAY INVOLVE POTENTIAL RISKS OF DEATH, PERSONAL INJURY, OR SEVERE PROPERTY OR ENVIRONMENTAL DAMAGE ("CRITICAL APPLICATIONS"). TI SEMICONDUCTOR PRODUCTS ARE NOT DESIGNED, AUTHORIZED, OR WARRANTED TO BE SUITABLE FOR USE IN LIFE-SUPPORT DEVICES OR SYSTEMS OR OTHER CRITICAL APPLICATIONS. INCLUSION OF TI PRODUCTS IN SUCH APPLICATIONS IS UNDERSTOOD TO BE FULLY AT THE CUSTOMER'S RISK.

In order to minimize risks associated with the customer's applications, adequate design and operating safeguards must be provided by the customer to minimize inherent or procedural hazards.

TI assumes no liability for applications assistance or customer product design. TI does not warrant or represent that any license, either express or implied, is granted under any patent right, copyright, mask work right, or other intellectual property right of TI covering or relating to any combination, machine, or process in which such semiconductor products or services might be or are used. TI's publication of information regarding any third party's products or services does not constitute TI's approval, warranty or endorsement thereof.