

Agilent 11636A,B power dividers

These power dividers provide good match and excellent tracking characteristics from dc to 26.5 GHz. Power dividers are recommended for applications such as transmission line fault testing, as well as power combining. They are not recommended for ratio and leveling applications.

Agilent 11636A

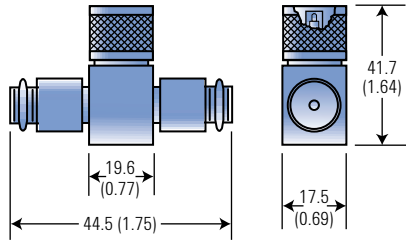

Dimensions are in mm (inches) nominal, unless otherwise specified.

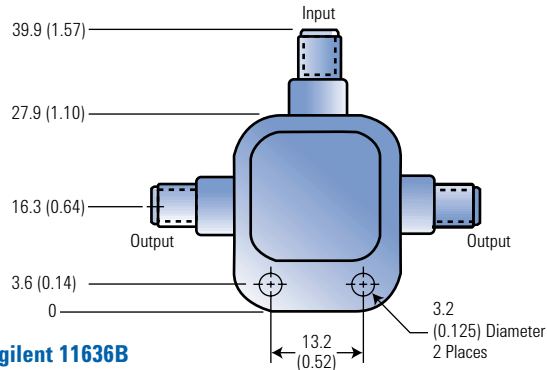

Agilent 11636B

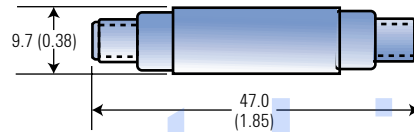

Dimensions are in mm (inches) nominal, unless otherwise specified.



Agilent 87302C

Agilent 87302/303/304C hybrid power dividers

These power dividers are designed for power splitting applications that require minimal insertion loss and high isolation between ports. They are available in three models that cover multi-octave bands to 26.5 GHz. Models with narrower frequency coverage have less insertion loss. Hybrid dividers have insertion loss between the main line and output port which is 1 to 2 dB less than equivalent resistive power splitters. Designed for critical signal processing applications, phase and amplitude tracking between the two output ports is controlled and specified.

Agilent model	Frequency range (GHz)	Max. SWR	Maximum insertion loss (dB)	Minimum isolation (dB)	Maximum amplitude tracking (dB) ¹	Maximum phase tracking (deg) ¹
11636A	dc to 18	1.35	6.0 typ. ²		0.5 ³	±2° typ.
11636B	dc to 26.5	1.29	7.5		0.25 ³	±2° typ.
87302C	0.5 ST	1.45	1.5	19	0.3	6
	26.5 ST	1.60	1.9	19	0.5	10
87303C	1.0 to 18	1.45	1.2	19	0.3	6
	18 to 26.5	1.60	1.6	21	0.5	10
87304C	2.0 to 18	1.45	1.1	19	0.3	6
	18 to 26.5	1.60	1.4	18	0.5	10

Power Rating: 10 watts 87302C/3C/4C, 1 watt CW 11636A/B, (2:1 maximum load SWR)
 Connectors: 3.5 mm (f), (SMA compatible)
 Weight: 170 g (6 oz) net, 340 g (12 oz) shipping

¹ Amplitude and phase tracking are the ratio of one output to the other in dB or degrees, respectively.
² 5.8 to 7.2 dB up to 10 GHz; 5.8 to 7.5 dB up to 18 GHz.
³ at 18 GHz.

Agilent 87302/303/304C

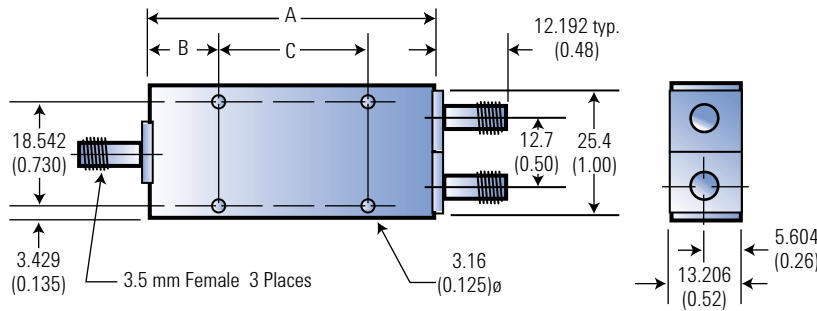

Dimensions are in mm (inches) nominal, unless otherwise specified.

Agilent model	A	B	C
87302C	196.85 (7.75)	28.702 (1.13)	139.7 (5.50)
87303C	105.41 (4.15)	26.162 (1.03)	2.10 (53.34)
87304C	57.15 (2.25)	28.702 (1.13)	0.00 (0.00)

Dimensions are in mm (inches) nominal, unless otherwise specified.

Agilent 11667A



Agilent 11667B



Agilent 11667A,B power splitters

These power splitters feature excellent match and tracking between outputs, operating from dc to 26.5 GHz. Power splitters are recommended for external source leveling and ratio measurements.

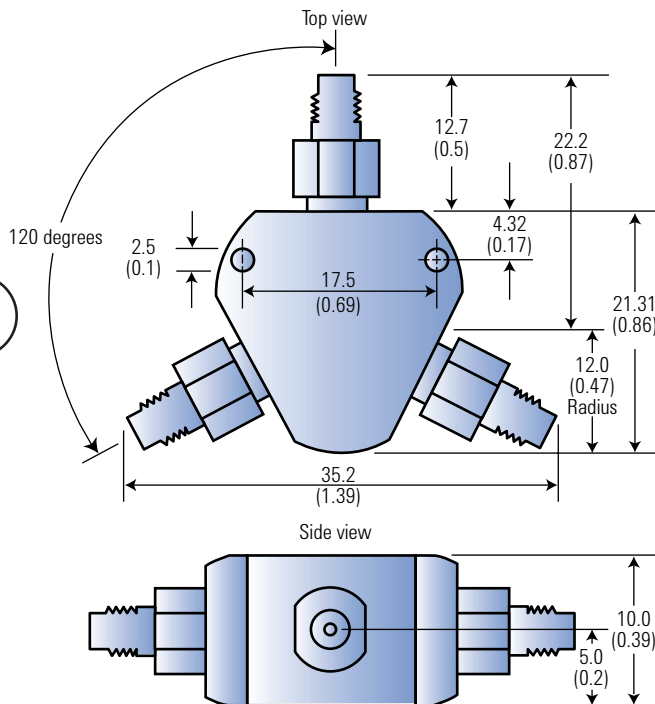

Dimensions are in mm (inches) nominal, unless otherwise specified.

Agilent 11667C



Agilent 11667C power splitter

This two-resistor power splitter is recommended for applications that require external source leveling, or for ratio measurements. It covers the entire dc to 50 GHz frequency band by use of 2.4 mm connectors and advanced micro-circuitry for the resistive components. These two-resistor type splitters provide excellent output SWR at the auxiliary arm when used for source leveling or ratio measurement applications. The tracking between output arms over a frequency range from dc to 50 GHz allows wideband measurements to be made with a minimum of uncertainty.



Agilent 11850C,D

Agilent 11850C,D power splitter

These three-way power splitters are designed for source leveling or ratio measurements. One output port provides the reference for a leveling or ratio detector, while the other two ports can be used for two independent transmission measurements or a comparison measurement.

Specifications

Agilent model	Frequency range	Equivalent output SWR (nominal 50 Ω)	Maximum input power	Nominal Insertion loss (input to either output)	Tracking between any two ports	Connectors	Shipping weight lb (kg)
11667A Option 001 Option 002	dc to 18.0 GHz	1.10: dc to 4 GHz 1.20: dc to 8 GHz 1.33: dc to 18 GHz	0.5 W	7 dB	0.20 dB to 8 GHz 0.25 dB to 18 GHz	N (f) all ports Opt. 001: N (m) in, N (f) out Opt. 002: N (f) in, APC-7 out	0.2 (0.5)
11667B	dc to 26.5 GHz	1.22	0.5 W	7 dB	<0.25 dB	3.5 mm (f) all ports	0.14 (0.3)
11667C	dc to 50 GHz	1.65	0.5 W	8.5 dB	<0.40 dB	2.4 mm (f) all ports	0.14 (0.3)
11850C	dc to 3.0 GHz	1.22	0.1 W	9.5 dB + 1 dB/GHz	+0.25 dB, ±3 °	N (f) 50 Ω all ports	0.2 (0.5)
11850D	dc to 2 GHz	1.09		7.8 dB	±0.2 dB, ±2.5 °	N (f) 50 Ω in N (f) 75 Ω out	0.2 (0.5)



Agilent 0955-0751

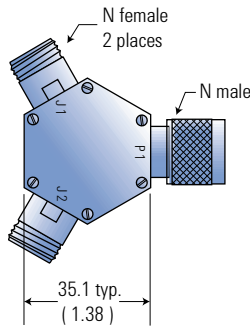

Agilent 0955-0751

Dimensions are in mm (inches) nominal, unless otherwise specified.

Agilent 0955-0751 power splitter

This power splitter is recommended for most 50 Ω economy network analyzer applications. A two resistor splitter provides excellent output SWR at the auxiliary arm over frequency allowing wideband measurements to be made with minimum uncertainty. The frequency range is 300 KHz to 3 GHz. Tracking flatness between output areas is within ± 0.25 dB and ± 3 degrees of phase. Equivalent source match is 25 dB to 2 GHz and 20 dB to 3 GHz. Insertion loss is 6 dB nominal. Input port match is 20 dB to 3 GHz. Connectors are type-N (f) output and type-N (m) input. Power rating is 1 watt.

Agilent 0955-0752 power splitter

This 75 Ω power splitter has a frequency range from 300 KHz to 3 GHz. Tracking flatness is within ± 0.25 dB and ± 3 degrees of phase. Equivalent source match is 25 dB to 2 GHz and 20 dB to 3 GHz. Insertion loss is 6 dB nominal. Input port match is 20 dB to 3 GHz. Connectors are type-N (m) input, type-N (f) output. Power rating is 1 watt.