

# DATA SHEET



Datasheet.Live

## **TEA6842H**

New In Car Entertainment (NICE)  
extended car radio

Product specification

2003 Dec 19

# New In Car Entertainment (NICE) extended car radio

TEA6842H

<b>CONTENTS</b>		
1	FEATURES	11
2	GENERAL DESCRIPTION	12
3	ORDERING INFORMATION	12.1
4	QUICK REFERENCE DATA	12.1.1
5	BLOCK DIAGRAM	12.1.1.1
6	PINNING	12.1.1.2
7	FUNCTIONAL DESCRIPTION	12.1.1.3
7.1	Oscillators	12.1.1.4
7.1.1	VCO	12.2
7.1.2	Crystal oscillator	12.2.1
7.1.3	PLL	12.2.2
7.2	FM signal channel	12.2.3
7.2.1	DAA	12.2.4
7.2.2	FM I/Q mixer	12.2.5
7.2.3	FM keyed AGC	12.2.6
7.2.4	FM IF amplifiers	12.2.7
7.2.5	FM demodulator	12.2.8
7.2.6	FM MPX soft mute	12.2.9
7.2.7	Ultrasonic noise detector	13
7.3	AM signal channel	14
7.3.1	AM tuner	15
7.3.2	AM RF AGC and IF2 AGC	16
7.3.3	AM AF or IF2 switch	16.1
7.3.4	AM soft mute	16.2
7.3.5	AM noise blanker	16.3
7.4	FM and AM level detector	16.4
7.5	Input for external mute	16.5
7.6	Buffer output for weather band flag	17
7.7	Test mode	18
8	LIMITING VALUES	19
9	THERMAL CHARACTERISTICS	20
10	DC CHARACTERISTICS	
		AC CHARACTERISTICS
		I <sup>2</sup> C-BUS PROTOCOL
		I <sup>2</sup> C-bus specification
		Data transfer
		I <sup>2</sup> C-bus pull-up resistors
		Frequency setting
		Default settings
		I <sup>2</sup> C-bus protocol
		Data transfer mode and IC address
		Write mode: data byte 1
		Write mode: data byte 2
		Write mode: data byte 3
		Write mode: data byte 4
		Write mode: data byte 5
		Write mode: data byte 6
		Write mode: data byte 7
		Read mode: data byte 1
		TEST AND APPLICATION INFORMATION
		INTERNAL CIRCUITRY
		PACKAGE OUTLINE
		SOLDERING
		Introduction to soldering surface mount packages
		Reflow soldering
		Wave soldering
		Manual soldering
		Suitability of surface mount IC packages for wave and reflow soldering methods
		DATA SHEET STATUS
		DEFINITIONS
		DISCLAIMERS
		PURCHASE OF PHILIPS I <sup>2</sup> C COMPONENTS

# New In Car Entertainment (NICE) extended car radio

TEA6842H

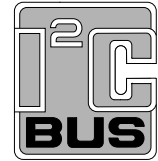

## 1 FEATURES

- FM mixer for conversion of FM RF from 65 to 108 MHz to IF of 10.7 MHz; the mixer provides inherent image rejection
- FM RF mixer can be set to receive weather band radio up to 162.55 MHz
- Buffer output for weather band flag
- AM mixer 1 for conversion of AM RF to AM IF1 of 10.7 MHz
- LC tuner oscillator providing mixer frequencies for FM mixer and AM mixer 1
- AM mixer 2 for conversion of AM IF1 to AM IF2 of 450 kHz
- Crystal oscillator providing mixer frequencies for AM mixer 2 and reference for synthesizer PLL, IF count, timing for inaudible Radio Data System (RDS) update and reference frequency for car audio signal processor ICs
- Fast synthesizer PLL tuning system with local control for inaudible RDS updating
- Timing function for RDS update algorithm and control signal output for car audio signal processor ICs (TEA688x, SAA77xx) or car radio integrated signal processor IC (TEF689x)
- Digital auto alignment circuit for conversion of LC oscillator tuning voltage to controlled alignment voltage of FM antenna tank circuit
- AGC PIN diode drive circuit for FM RF AGC; AGC detection at FM mixer input; the AGC PIN diode current can be set to a fixed value to allow local function for search tuning; AGC threshold is a programmable and keyed function switchable via the I<sup>2</sup>C-bus
- FM IF linear amplifiers with high dynamic input range
- FM quadrature demodulator with automatic centre frequency adjustment and Total Harmonic Distortion (THD) compensation and level driven soft mute; soft mute characteristic is adjustable via the I<sup>2</sup>C-bus
- Level detector for AM and FM with temperature compensated output voltage; starting point and slope of level output is programmable via the I<sup>2</sup>C-bus
- AM RF PIN diode drive circuit; AGC threshold detection at AM mixer 1 and IF2 AGC input; threshold is programmable via the I<sup>2</sup>C-bus; AM IF2 AGC and demodulator
- AM AGC voltage buffer
- AM AF output switchable to provide AM IF2 for AM stereo decoder
- AM noise blanker with blanking at AM IF2
- Ultrasonic noise detector
- Pin for external mute control
- Several test modes available for fast IC and system tests.

## 2 GENERAL DESCRIPTION

The TEA6842H is a single IC with car radio tuner for AM, FM and Weather Band (WB) intended for microcontroller tuning with the I<sup>2</sup>C-bus. It provides the following functions:

- AM double conversion receiver for LW, MW and SW (31 m, 41 m and 49 m bands) with IF1 = 10.7 MHz and IF2 = 450 kHz
- FM single conversion receiver with integrated image rejection for IF = 10.7 MHz capable of selecting US FM, US weather, Europe FM, East Europe FM and Japan FM bands
- The tuning system includes FM mixer, AM mixer 1, AM mixer 2, crystal oscillator, VCO and PLL synthesizer on one chip.

## 3 ORDERING INFORMATION

TYPE NUMBER	PACKAGE		
	NAME	DESCRIPTION	VERSION
TEA6842H	LQFP80	plastic low profile quad flat package; 80 leads; body 12 × 12 × 1.4 mm	SOT315-1

# New In Car Entertainment (NICE) extended car radio

TEA6842H

## 4 QUICK REFERENCE DATA

SYMBOL	PARAMETER	CONDITIONS	MIN.	TYP.	MAX.	UNIT
$V_{DDA(n)}$	analog supply voltage 1 to 4 and 6		8	8.5	9	V
$I_{DDA(tot)}$	total analog supply currents 1 to 4 and 6 and mixer bias currents	FM mode; data byte 5: bit TMS3 = 1	45	60	69	mA
		AM mode; data byte 5: bit TMS3 = 1	39	50	59	mA
$V_{DDA5}$	analog supply voltage 5		4.75	5	5.25	V
$I_{DDA5}$	analog supply current 5	FM mode; data byte 5: bit 5 = 0, bit 6 = 0	6.5	9.3	11.2	mA
		AM mode; data byte 5: bit 5 = 1, bit 6 = 1	12.7	17.4	22.1	mA
$V_{DDD}$	digital supply voltage		4.75	5	5.25	V
$I_{DDD}$	digital supply current	FM mode	18	23	28	mA
		AM mode	18	23	28	mA
$f_{AM(ant)}$	AM input frequency	LW	0.144	–	0.288	MHz
		MW	0.522	–	1.710	MHz
		SW	5.85	–	9.99	MHz
$f_{FM(ant)}$	FM input frequency		65	–	108	MHz
$f_{FM(WB)(ant)}$	FM weather band input frequency		162.4	–	162.55	MHz
$T_{amb}$	ambient temperature		–40	–	+85	°C

# New In Car Entertainment (NICE) extended car radio

## TEA6842H

### 5 BLOCK DIAGRAM

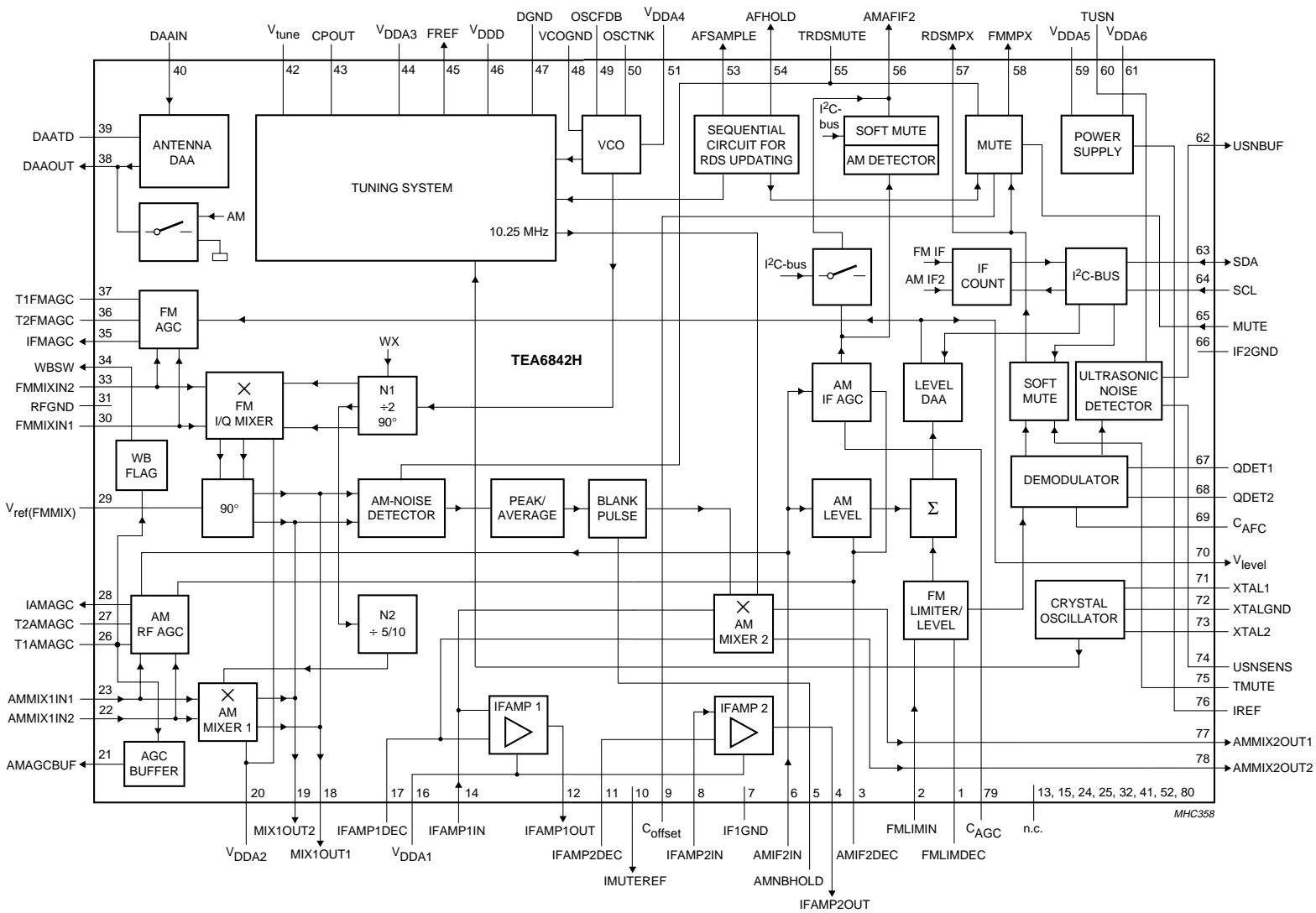

Fig.1 Block diagram.

## New In Car Entertainment (NICE) extended car radio

TEA6842H

### 6 PINNING

SYMBOL	PIN	DESCRIPTION
FMLIMDEC	1	FM limiter decoupling
FMLIMIN	2	FM limiter input (10.7 MHz)
AMIF2DEC	3	decoupling for AM IF2 input
IFAMP2OUT	4	IF amplifier 2 output (10.7 MHz)
AMNBHOLD	5	AM noise blanker threshold
AMIF2IN	6	AM IF2 input (450 kHz) for demodulator AGC and AM level detector
IF1GND	7	AM IF1 ground
IFAMP2IN	8	IF amplifier 2 input (10.7 MHz)
C <sub>offset</sub>	9	DC feedback for offset compensation RDS mute
IMUTEREF	10	mute reference current output for testing
IFAMP2DEC	11	IF amplifier 2 decoupling and AGC capacitor for AM noise blanker
IFAMP1OUT	12	IF amplifier 1 output (10.7 MHz)
n.c.	13	not connected
IFAMP1IN	14	IF amplifier 1 and AM mixer 2 input (10.7 MHz)
n.c.	15	not connected
V <sub>DDA1</sub>	16	analog supply voltage 1 (8.5 V) for IF amplifier 1 and 2
IFAMP1DEC	17	AM mixer 2 and FM IF amplifier 1 decoupling
MIX1OUT1	18	FM mixer and AM mixer 1 IF output 1 (10.7 MHz)
MIX1OUT2	19	FM mixer and AM mixer 1 IF output 2 (10.7 MHz)
V <sub>DDA2</sub>	20	analog supply voltage 2 (8.5 V) for FM mixer and AM mixer 1
AMAGCBUF	21	buffer output of AM AGC voltage
AMMIX1IN2	22	AM mixer 1 input 2
AMMIX1IN1	23	AM mixer 1 input 1
n.c.	24	not connected
n.c.	25	not connected
T1AMAGC	26	1st time constant of AM front-end AGC
T2AMAGC	27	2nd time constant of AM front-end AGC
IAMAGC	28	PIN diode drive current output of AM front-end AGC
V <sub>ref(FMMIX)</sub>	29	reference voltage for FM I/Q mixer
FMMIXIN1	30	FM RF mixer input 1
RFGND	31	RF ground
n.c.	32	not connected
FMMIXIN2	33	FM RF mixer input 2
WBSW	34	buffered weather band flag output
IFMAGC	35	PIN diode drive current output of FM front-end AGC
T2FMAGC	36	2nd time constant of FM front-end AGC
T1FMAGC	37	1st time constant of FM front-end AGC
DAAOUT	38	output of digital auto alignment circuit for antenna tank circuit
DAATD	39	temperature compensation diode for digital auto alignment circuit for antenna tank circuit
DAAIN	40	input of digital auto alignment circuit for antenna tank circuit

## New In Car Entertainment (NICE) extended car radio

TEA6842H

SYMBOL	PIN	DESCRIPTION
n.c.	41	not connected
V <sub>tune</sub>	42	tuning voltage
CPOUT	43	charge pump output
V <sub>DDA3</sub>	44	analog supply voltage 3 (8.5 V) for tuning PLL
FREF	45	reference frequency output for signal processor IC
V <sub>DDD</sub>	46	digital supply voltage (5 V)
DGND	47	digital ground
VCOGND	48	VCO ground
OSCFDB	49	VCO feedback
OSCTNK	50	VCO tank circuit
V <sub>DDA4</sub>	51	analog supply voltage 4 (8.5 V) for VCO
n.c.	52	not connected
AFSAMPLE	53	AF sample flag output for car audio signal processor IC
AFHOLD	54	AF hold flag output for car audio signal processor IC
TRDSMUTE	55	time constant for RDS update mute
AMAFIF2	56	AM demodulator AF output or IF2 output for AM stereo (multiplexed by I <sup>2</sup> C-bus)
RDSMPX	57	MPX output for RDS decoder and signal processor (not muted)
FMMPX	58	FM demodulator MPX output
V <sub>DDA5</sub>	59	analog supply voltage 5 (5 V) for on-chip power supply
TUSN	60	time constant for ultrasonic noise detector
V <sub>DDA6</sub>	61	analog supply voltage 6 (8.5 V) for on-chip power supply
USNBUF	62	buffer output for ultrasonic noise detector
SDA	63	I <sup>2</sup> C-bus data line input and output
SCL	64	I <sup>2</sup> C-bus clock line input
MUTE	65	mute control input
IF2GND	66	AM IF2 ground
QDET1	67	quadrature demodulator tank 1
QDET2	68	quadrature demodulator tank 2
C <sub>AFC</sub>	69	FM demodulator AFC capacitor
V <sub>level</sub>	70	level voltage output for AM and FM
XTAL1	71	crystal oscillator 1
XTALGND	72	crystal oscillator ground
XTAL2	73	crystal oscillator 2
USNSENS	74	sensitivity control of ultrasonic noise detector
TMUTE	75	time constant for mute control voltage
IREF	76	reference current for power supply
AMMIX2OUT1	77	AM mixer 2 output 1 (450 kHz)
AMMIX2OUT2	78	AM mixer 2 output 2 (450 kHz)
C <sub>AGC</sub>	79	AM IF AGC capacitor
n.c.	80	not connected

New In Car Entertainment (NICE)  
extended car radio

TEA6842H

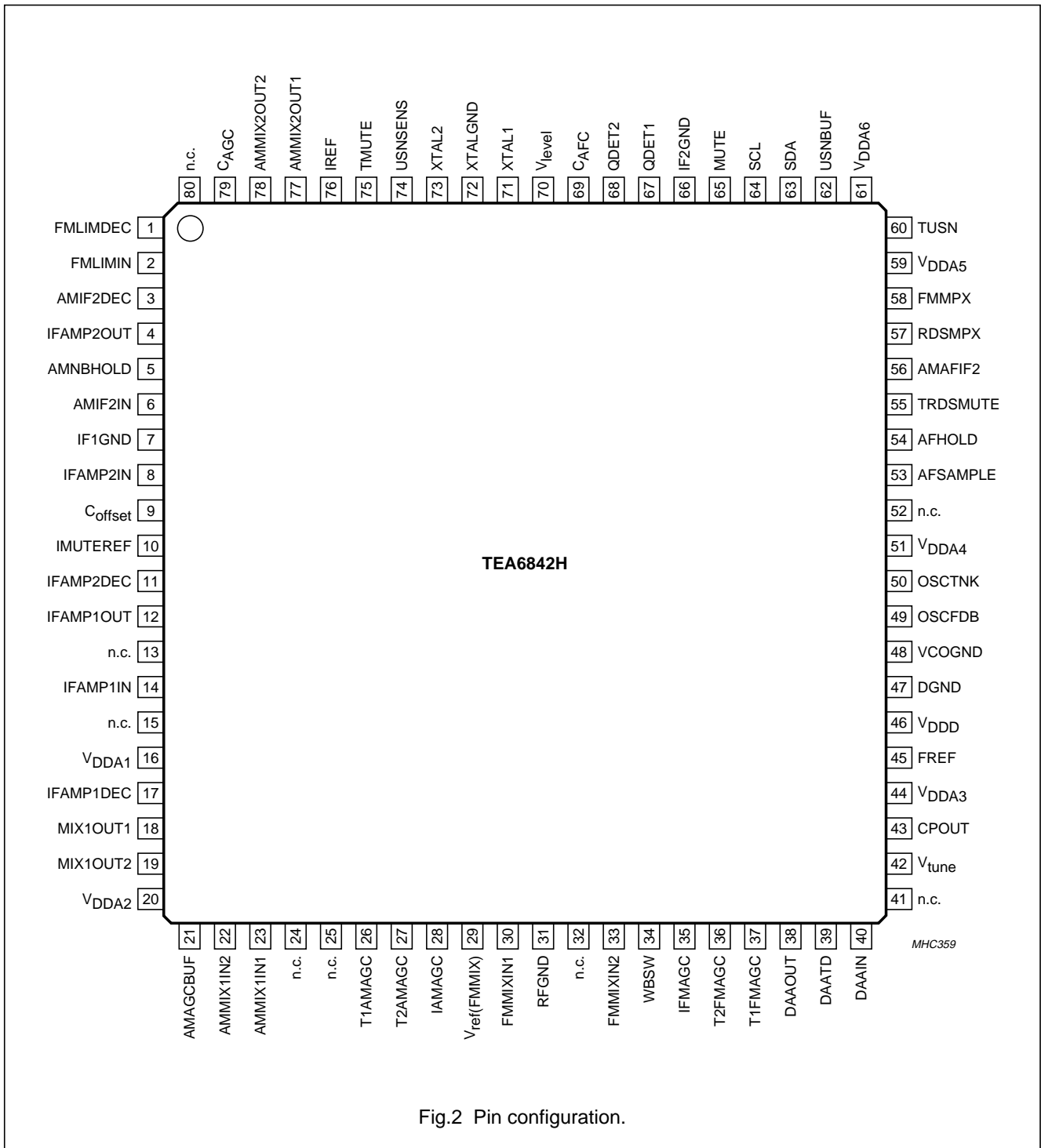

Fig.2 Pin configuration.



## New In Car Entertainment (NICE) extended car radio

TEA6842H

### 7 FUNCTIONAL DESCRIPTION

#### 7.1 Oscillators

##### 7.1.1 VCO

The L and C tuned VCO provides the local oscillator signal for both FM and AM mixer 1. It has a frequency range of 151.2 to 248.2 MHz.

##### 7.1.2 CRYSTAL OSCILLATOR

The crystal oscillator provides a 20.5 MHz signal that is used for:

- Reference frequency for frequency synthesizer PLL
- Local oscillator for AM mixer 2
- Reference frequency for the IF counter
- Timing signal for the RDS update algorithm
- Reference frequency (75.368 kHz) for the TEA688x (car audio signal processor - CASP) or TEF689x (car radio integrated signal processor - CRISP).

##### 7.1.3 PLL

Fast synthesizer PLL tuning system with local control for inaudible RDS updating.

#### 7.2 FM signal channel

##### 7.2.1 DAA

FM RF Digital Auto Alignment (DAA) circuitry for the conversion of the VCO tuning voltage to a controlled alignment voltage for the FM antenna tank circuit.

##### 7.2.2 FM I/Q MIXER

FM quadrature mixer converts FM RF (65 to 162.55 MHz) to IF of 10.7 MHz. The FM mixer provides inherent image rejection and high RF sensitivity.

It is capable of tuning the US FM, US weather, Europe FM, Japan FM and East Europe FM bands:

- US FM = 87.9 to 107.9 MHz
- US weather FM = 162.4 to 162.55 MHz
- Europe FM = 87.5 to 108 MHz
- Japan FM = 76 to 91 MHz
- East Europe FM = 65.8 to 74 MHz.

##### 7.2.3 FM KEYED AGC

The AGC threshold is programmable and the keyed AGC function is switchable via the I<sup>2</sup>C-bus.

If the keyed AGC function is activated, the AGC function is keyed by the narrow band level (IF).

The AGC PIN diode drive can be set via the I<sup>2</sup>C-bus to local function for search tuning.

##### 7.2.4 FM IF AMPLIFIERS

The two FM IF amplifiers provide 10 dB and 8.5 dB amplification with high linearity and dynamic range.

##### 7.2.5 FM DEMODULATOR

The FM quadrature demodulator includes automatic centre frequency adjustment and THD compensation.

##### 7.2.6 FM MPX SOFT MUTE

Muting depth and start of muting are adjustable via the I<sup>2</sup>C-bus.

##### 7.2.7 ULTRASONIC NOISE DETECTOR

This is an ultrasonic noise detector with programmable sensitivity by external resistor. The gain of the ultrasonic noise detector also depends of the RF level.

Attack and decay time can be set with an external timing capacitor. The detector has a buffered output.

#### 7.3 AM signal channel

##### 7.3.1 AM TUNER

The AM tuner is realized in a double conversion technique and is capable of selecting LW, MW and SW bands.

AM mixer 1 converts AM RF to IF1 of 10.7 MHz, while AM mixer 2 converts IF1 of 10.7 MHz to IF2 of 450 kHz:

- LW = 144 to 288 kHz
- MW = 522 to 1710 kHz (European and US AM band)
- SW = 5.85 to 9.99 MHz (including the 31 m, 41 m and 49 m bands).

##### 7.3.2 AM RF AGC AND IF2 AGC

The AM RF includes a PIN diode drive circuit. The threshold detection points for AM AGC are performed at AM mixer 1 and AM IF2. AGC thresholds are programmable at AM mixer 1 input via the I<sup>2</sup>C-bus.

##### 7.3.3 AM AF OR IF2 SWITCH

The AM output provides either a demodulated AM Audio Frequency (AF) or the corresponding AM IF2 signal. The IF2 signal can be used for AM stereo decoder processing.

## New In Car Entertainment (NICE) extended car radio

TEA6842H

### 7.3.4 AM SOFT MUTE

The AM detector output is either not muted or signal strength dependent soft muted audio. The soft mute function can be switched off via the I<sup>2</sup>C-bus.

### 7.3.5 AM NOISE BLANKER

The detection point for the AM noise blanker is the output stage of AM mixer 1, while blanking is realized at the output of the mixer 2.

Trigger sensitivity can be modified by changing the resistor value at pin AMNBHOLD.

### 7.4 FM and AM level detector

FM and AM level detectors provide the temperature compensated output voltage. The starting points and slopes of the level detector outputs are programmable via the I<sup>2</sup>C-bus.

### 7.5 Input for external mute

A LOW signal at pin MUTE starts muting with 1 ms slope. Mute is active as long as the control voltage is LOW. A HIGH at pin MUTE stops muting with 1 ms slope.

### 7.6 Buffer output for weather band flag

In weather band mode the output is HIGH.

### 7.7 Test mode

The test mode of the IC is activated by connecting pin FREF through a 100 k $\Omega$  resistor to V<sub>DDA1</sub>.

The test mode is intended for IC test during IC and radio manufacturing.

In test mode the settling time of the AM IF2 AGC is reduced to less than 100 ms in the nominal application.

## 8 LIMITING VALUES

In accordance with the Absolute Maximum Rating System (IEC 60134).

SYMBOL	PARAMETER	CONDITIONS	MIN.	MAX.	UNIT
V <sub>DDA1</sub>	analog supply voltage 1 for IF amplifier 1 and 2		-0.3	+10	V
V <sub>DDA2</sub>	analog supply voltage 2 for FM mixer and AM mixer 1		-0.3	+10	V
V <sub>DDA3</sub>	analog supply voltage 3 for tuning PLL		-0.3	+10	V
V <sub>DDA4</sub>	analog supply voltage 4 for VCO		-0.3	+10	V
V <sub>DDA5</sub>	analog supply voltage 5 for on-chip power supply		-0.3	+6.5	V
V <sub>DDA6</sub>	analog supply voltage 6 for on-chip power supply		-0.3	+10	V
V <sub>DD</sub>	digital supply voltage		-0.3	+6.5	V
$\Delta V_{DD8.5-DD5}$	difference between any 8.5 V supply voltage and any 5 V supply voltage	note 1	-0.3	-	V
T <sub>stg</sub>	storage temperature		-55	+150	°C
T <sub>amb</sub>	ambient temperature		-40	+85	°C
V <sub>es</sub>	electrostatic handling voltage	note 2	-200	+200	V
		note 3	-2000	+2000	V

### Notes

- To avoid damages and wrong operation it is necessary to keep all 8.5 V supply voltages at a higher level than any 5 V supply voltage. This is also necessary during power-on and power-down sequences. Precautions have to be provided in such a way that interferences can not pull down the 8.5 V supply below the 5 V supply.
- Machine model (R = 0  $\Omega$ , C = 200 pF).
- Human body model (R = 1.5 k $\Omega$ , C = 100 pF).

# New In Car Entertainment (NICE) extended car radio

TEA6842H

## 9 THERMAL CHARACTERISTICS

SYMBOL	PARAMETER	CONDITIONS	VALUE	UNIT
$R_{th(j-a)}$	thermal resistance from junction to ambient	in free air	54	K/W

## 10 DC CHARACTERISTICS

$V_{MIX1OUT} = V_{AMMIX2OUT} = V_{DDA(n)} = 8.5\text{ V}$ ;  $V_{DDA5} = 5\text{ V}$ ;  $V_{DDD} = 5\text{ V}$ ;  $T_{amb} = 25\text{ }^{\circ}\text{C}$ ; unless otherwise specified.

SYMBOL	PARAMETER	CONDITIONS	MIN.	TYP.	MAX.	UNIT
<b>Supply voltage</b>						
$V_{DDA(n)}$	analog supply voltages 1 to 4 and 6		8	8.5	9	V
$V_{MIX1OUT}$ ; $V_{AMMIX2OUT}$	mixer supply voltages		8	8.5	9	V
$V_{DDA5}$	analog supply voltage 5		4.75	5	5.25	V
$V_{DDD}$	digital supply voltage		4.75	5	5.25	V
<b>Supply current in FM mode</b>						
$I_{DDD}$	digital supply current		18	23	28	mA
$I_{DDA1}$	analog supply current 1 for IF amplifier 1 and 2		11	13	15	mA
$I_{DDA2}$	analog supply current 2 for FM mixer and AM mixer 1		4.2	5.2	6.2	mA
$I_{DDA3}$	analog supply current 3 for tuning PLL	data byte 5: bit TMS3 = 1	2.3	3	3.6	mA
$I_{DDA4}$	analog supply current 4 for VCO		5.2	6.5	7.8	mA
$I_{DDA5}$	analog supply current 5 for on-chip power supply		6.5	9.3	11.2	mA
$I_{DDA6}$	analog supply current 6 for on-chip power supply		16	20	24	mA
$I_{MIX1OUT1}$	bias current of FM mixer output 1		4.8	6	7.2	mA
$I_{MIX1OUT2}$	bias current of FM mixer output 2		4.8	6	7.2	mA
<b>Supply current in AM mode</b>						
$I_{DDD}$	digital supply current		18	23	28	mA
$I_{DDA1}$	analog supply current 1 for AM mixer 2		–	240	–	$\mu\text{A}$
$I_{DDA2}$	analog supply current 2 for FM mixer and AM mixer 1		1.6	2	2.4	mA
$I_{DDA3}$	analog supply current 3 for tuning PLL	data byte 5: bit TMS3 = 1	1.3	1.7	2.1	mA
$I_{DDA4}$	analog supply current 4 for VCO		5	6.5	8	mA
$I_{DDA5}$	analog supply current 5 for on-chip power supply		12.7	17.4	22.1	mA
$I_{DDA6}$	analog supply current 6 for on-chip power supply		15	19	23	mA
$I_{MIX1OUT1}$	bias current of AM mixer 1 output 1		4.8	6	7.2	mA
$I_{MIX1OUT2}$	bias current of AM mixer 1 output 2		4.8	6	7.2	mA

## New In Car Entertainment (NICE) extended car radio

TEA6842H

SYMBOL	PARAMETER	CONDITIONS	MIN.	TYP.	MAX.	UNIT
I <sub>AMMIX2OUT1</sub>	bias current of AM mixer 2 output 1		3.6	4.5	5.4	mA
I <sub>AMMIX2OUT2</sub>	bias current of AM mixer 2 output 2		3.6	4.5	5.4	mA
<b>Power supply reference current generator: pin IREF</b>						
V <sub>o(ref)</sub>	output reference voltage		4	4.25	4.5	V
R <sub>o</sub>	output resistance		8	11	13	kΩ
I <sub>o(max)</sub>	maximum output current		-100	-	+100	nA

### 11 AC CHARACTERISTICS

V<sub>MIX1OUT</sub> = V<sub>AMMIX2OUT</sub> = V<sub>DDA(n)</sub> = 8.5 V; V<sub>DDA5</sub> = 5 V; V<sub>DD</sub> = 5 V; T<sub>amb</sub> = 25 °C; see Figs 15 and 16; unless otherwise specified.

SYMBOL	PARAMETER	CONDITIONS	MIN.	TYP.	MAX.	UNIT
<b>Voltage controlled oscillator</b>						
f <sub>osc</sub>	oscillator frequency		151.2	-	248.2	MHz
C/N	carrier-to-noise ratio	f <sub>osc</sub> = 200 MHz; Δf = 10 kHz; B = 1 Hz	-	101	-	dBc
RR	ripple rejection $\frac{\Delta f_{osc}}{f_{osc}}$	f <sub>ripple</sub> = 100 Hz; V <sub>DDA4(ripple)</sub> = 100 mV (RMS) f <sub>osc</sub> = 250 MHz f <sub>osc</sub> = 200 MHz	90 92	97 99	- -	dB dB
<b>Crystal oscillator: pins XTAL1, XTALGND and XTAL2</b>						
f <sub>osc</sub>	oscillator frequency		-	20.5	-	MHz
R <sub>i</sub>	real part of input impedance	V <sub>XTAL1</sub> - V <sub>XTAL2</sub> = 1 mV	-500	-	-	Ω
C <sub>i</sub>	input capacitance		8	10	12	pF
V <sub>o(osc)(rms)</sub>	oscillator output voltage (RMS value)		240	350	500	mV
C/N	carrier-to-noise ratio	f <sub>osc</sub> = 20.5 MHz (10.25 MHz); Δf = 10 kHz	-	112	-	$\frac{dBc}{\sqrt{Hz}}$
<b>Oscillator divider N1</b>						
N1	oscillator divider ratio	FM mode standard, East Europe and local weather band (WX)	- -	2 1	- -	
<b>Oscillator divider N2</b>						
N2	oscillator divider ratio	AM mode LW and MW SW	- -	10 5	- -	

# New In Car Entertainment (NICE) extended car radio

TEA6842H

SYMBOL	PARAMETER	CONDITIONS	MIN.	TYP.	MAX.	UNIT
<b>Synthesizer</b>						
PROGRAMMABLE DIVIDER						
$N_{\text{prog}}$	programmable divider ratio		512	–	32767	
$\Delta N_{\text{step}}$	programmable divider step size		–	1	–	
REFERENCE FREQUENCY DIVIDER						
$N_{\text{ref}}$	crystal oscillator divider ratio	$f_{\text{osc}} = 20.5 \text{ MHz}$ $f_{\text{ref}} = 100 \text{ kHz}$ $f_{\text{ref}} = 50 \text{ kHz}$ $f_{\text{ref}} = 25 \text{ kHz}$ $f_{\text{ref}} = 20 \text{ kHz}$ $f_{\text{ref}} = 10 \text{ kHz}$	–	205	–	
			–	410	–	
			–	820	–	
			–	1025	–	
			–	2050	–	
CHARGE PUMP: PIN CPOUT						
$I_{\text{sink(cp1)}}$	low charge pump 1 sink current	$0.4 \text{ V} < V_{\text{CPOUT}} < 7.6 \text{ V}$ ; data byte 4: bit 0 = 0, bit 1 = 1, bit 2 = 1 for FM weather band; $f_{\text{VCO}} > f_{\text{ref}} \times \text{divider ratio}$	–	300	–	$\mu\text{A}$
$I_{\text{source(cp1)}}$	low charge pump 1 source current	$0.4 \text{ V} < V_{\text{CPOUT}} < 7.6 \text{ V}$ ; data byte 4: bit 0 = 0, bit 1 = 1, bit 2 = 1 for FM weather band; $f_{\text{VCO}} < f_{\text{ref}} \times \text{divider ratio}$	–	–300	–	$\mu\text{A}$
$I_{\text{sink(cp1)h}}$	high charge pump 1 sink current	$0.4 \text{ V} < V_{\text{CPOUT}} < 7.6 \text{ V}$ ; data byte 4: bit 0 = 1, bit 1 = 1, bit 2 = 1 for AM IF2 output; $N2 = 10$ (LW and MW); $f_{\text{VCO}} > f_{\text{ref}} \times \text{divider ratio}$	–	1	–	$\text{mA}$
$I_{\text{source(cp1)h}}$	high charge pump 1 source current	$0.4 \text{ V} < V_{\text{CPOUT}} < 7.6 \text{ V}$ ; data byte 4: bit 0 = 1, bit 1 = 1, bit 2 = 1 for AM IF2 output; $N2 = 10$ (LW and MW); $f_{\text{VCO}} < f_{\text{ref}} \times \text{divider ratio}$	–	–1	–	$\text{mA}$
$I_{\text{sink(cp2)}}$	charge pump 2 sink current	$0.3 \text{ V} < V_{\text{CPOUT}} < 7.1 \text{ V}$ ; data byte 4: bit 0 = 0, bit 1 = 0, bit 2 = 0; FM standard mode; $f_{\text{VCO}} > f_{\text{ref}} \times \text{divider ratio}$	–	130	–	$\mu\text{A}$
$I_{\text{source(cp2)}}$	charge pump 2 source current	$0.3 \text{ V} < V_{\text{CPOUT}} < 7.1 \text{ V}$ ; data byte 4: bit 0 = 0, bit 1 = 0, bit 2 = 0; FM standard mode; $f_{\text{VCO}} < f_{\text{ref}} \times \text{divider ratio}$	–	–130	–	$\mu\text{A}$

## New In Car Entertainment (NICE) extended car radio

TEA6842H

SYMBOL	PARAMETER	CONDITIONS	MIN.	TYP.	MAX.	UNIT
<b>CHARGE PUMP: PIN <math>V_{\text{tune}}</math></b>						
$I_{\text{sink(cp3)}}$	charge pump 3 sink current	$0.4 \text{ V} < V_{\text{tune}} < 7.6 \text{ V}$ ; data byte 4: bit 0 = 0, bit 1 = 0, bit 2 = 0; FM standard mode; $f_{\text{VCO}} > f_{\text{ref}} \times \text{divider ratio}$	–	3	–	mA
$I_{\text{source(cp3)}}$	charge pump 3 source current	$0.4 \text{ V} < V_{\text{tune}} < 7.6 \text{ V}$ ; data byte 4: bit 0 = 0, bit 1 = 0, bit 2 = 0; FM standard mode; $f_{\text{VCO}} < f_{\text{ref}} \times \text{divider ratio}$	–	–3	–	mA
<b>Antenna Digital Auto Alignment (DAA)</b>						
<b>DAA INPUT: PIN DAAIN</b>						
$I_{\text{bias(cp)}}$	charge pump buffer input bias current	$V_{\text{DAAIN}} = 0.4 \text{ to } 8 \text{ V}$	–10	–	+10	nA
$V_{\text{i(cp)}}$	charge pump buffer input voltage		0	–	8.5	V
<b>DAA OUTPUT: PIN DAAOUT</b>						
$V_{\text{o(min)}}$	minimum DAA output voltage	data byte 3 = 10000000; FM mode; $V_{\text{DAAIN}} = 0.5 \text{ V}$ ; $V_{\text{DAAATD}} = 0.45 \text{ V}$	–	–	0.5	V
$V_{\text{o(max)}}$	maximum DAA output voltage	data byte 3 = 11111111; FM mode; $V_{\text{DAAIN}} = 4 \text{ V}$ ; $V_{\text{DAAATD}} = 0.45 \text{ V}$	8	–	8.5	V
$V_{\text{o}}$	DAA output voltage	$I_{\text{DAAOUT}} < 100 \mu\text{A}$ ; AM mode	–	–	0.3	V
		data byte 3 = 10000000; FM mode; $V_{\text{DAAIN}} = 4 \text{ V}$ ; $V_{\text{DAAATD}} = 0.45 \text{ V}$ ; note 1	–	1.7	–	V
		data byte 3 = 11111111; FM mode; $V_{\text{DAAIN}} = 3 \text{ V}$ ; $V_{\text{DAAATD}} = 0.45 \text{ V}$ ; note 1	6.2	6.5	6.8	V
$V_{\text{o(n)}}$	DAA output noise voltage	data byte 3 = 11000000; FM mode; $V_{\text{DAAIN}} = 4 \text{ V}$ ; $V_{\text{DAAATD}} = 0.45 \text{ V}$ ; $B = 400 \text{ Hz to } 30 \text{ kHz}$	–	30	100	$\mu\text{V}$
$\Delta V_{\text{o(T)}}$	DAA output voltage variation with temperature	$T_{\text{amb}} = -40 \text{ to } +85 \text{ }^\circ\text{C}$ ; data byte 3 = 10101011	–8	–	+8	mV
$\Delta V_{\text{o(step)}}$	DAA step accuracy $V_{\text{DAAOUT}(n+1)} - V_{\text{DAAOUT}(n)}$	$n = 0 \text{ to } 127$ ; FM mode; $V_{\text{DAAOUT}} < 8 \text{ V}$ ; $V_{\text{DAAIN}} = 2 \text{ V}$ ; $V_{\text{DAAATD}} = 0.45 \text{ V}$	$0.5V_{\text{LSB}}$	$V_{\text{LSB}}$	$1.5V_{\text{LSB}}$	mV
$\Delta V_{\text{o(sink)}}$	DAA output variation caused by sink current	$V_{\text{DAAIN}} = 4 \text{ V}$ ; $I_{\text{L}} = 50 \mu\text{A}$	$-V_{\text{LSB}}$	–	$+V_{\text{LSB}}$	
$\Delta V_{\text{o(source)}}$	DAA output variation caused by source current	$V_{\text{DAAIN}} = 4 \text{ V}$ ; $I_{\text{L}} = -50 \mu\text{A}$	$-V_{\text{LSB}}$	–	$+V_{\text{LSB}}$	

# New In Car Entertainment (NICE) extended car radio

TEA6842H

SYMBOL	PARAMETER	CONDITIONS	MIN.	TYP.	MAX.	UNIT
$t_{st}$	DAA output settling time	$V_{DAAOUT} = 0.2$ to $8.25$ V; $C_L = 270$ pF	–	20	30	$\mu$ s
RR	ripple rejection $\frac{V_{DAAOUT}}{V_{DDA3}}$	data byte 3 = 10101011; FM mode; $V_{DAAIN} = 4$ V; $V_{DAATD} = 0.45$ V; $f_{ripple} = 100$ Hz; $V_{DDA3(ripple)} = 100$ mV	–	50	–	dB
$C_L$	DAA output load capacitance	$V_{DAAOUT} < 8$ V; FM mode	–	–	270	pF
<b>DAA TEMPERATURE COMPENSATION: PIN DAATD</b>						
$I_{source}$	compensation diode source current	$V_{DAATD} = 0.2$ to $1.2$ V	–50	–40	–30	$\mu$ A
$TC_{source}$	temperature coefficient of compensation diode source current	$V_{DAATD} = 0.2$ to $1.2$ V; $T_{amb} = -40$ to $+85$ °C	–300	–	+300	$\frac{10^{-6}}{K}$
<b>IF counter (FM IF1 or AM IF2 counter)</b>						
$N_{IF}$	IF counter length for AM and FM		–	8	–	bit
$T_{count(IF)}$	IF counter period	data byte 4: bit 7 = 1	–	2	–	ms
		data byte 4: bit 7 = 0	–	20	–	ms
$R_{precount}$	FM IF counter prescaler ratio	data byte 4: bit 3 = 1	–	10	–	
		data byte 4: bit 3 = 0	–	100	–	
$V_{FMLIMIN(sens)(rms)}$	FM sensitivity voltage (RMS value)	FM mode	–	30	100	$\mu$ V
N	counter result (decimal)	period = 2 ms; $f_{IF1} = 10.7$ MHz; $V_{FMLIMIN} = 100$ $\mu$ V (RMS) prescaler ratio = 10	–	92	–	
			–	214	–	
		period = 20 ms; $f_{IF1} = 10.7$ MHz; $V_{FMLIMIN} = 100$ $\mu$ V (RMS) prescaler ratio = 10	–	152	–	
			–	92	–	
$V_{AMIF2IN(sens)(rms)}$	AM sensitivity voltage (RMS value)	AM mode; $m = 0$	–	50	100	$\mu$ V
N	counter result (decimal)	period = 2 ms; $f_{IF2} = 450$ kHz; $V_{AMIF2IN} = 200$ $\mu$ V (RMS)	–	133	–	
		period = 20 ms; $f_{IF2} = 450$ kHz; $V_{AMIF2IN} = 200$ $\mu$ V (RMS)	–	40	–	

# New In Car Entertainment (NICE) extended car radio

TEA6842H

SYMBOL	PARAMETER	CONDITIONS	MIN.	TYP.	MAX.	UNIT
<b>Reference frequency for car signal processor IC; note 2</b>						
REFERENCE FREQUENCY DIVIDER						
$N_{\text{ref}}$	crystal oscillator divider ratio		–	272	–	
$f_{\text{ref}}$	reference frequency at pin FREF	$f_{\text{osc}} = 20.5 \text{ MHz}$	–	75.368	–	kHz
VOLTAGE GENERATOR: PIN FREF						
$V_{o(p-p)}$	AC output voltage (peak-to-peak value)	$R_L = \infty$	80	130	200	mV
$V_O$	DC output voltage		3.2	3.4	3.7	V
$R_o$	output resistance		–	–	50	k $\Omega$
$R_{L(\text{min})}$	minimum load resistance for first I <sup>2</sup> C-bus address		1	–	–	M $\Omega$
<b>AM signal channel</b>						
RF AGC STAGE INPUTS						
<i>Pins AMMIX1IN1 and AMMIX1IN2</i>						
$V_{i(\text{RF})}$	RF input voltage for AGC start level	data byte 5: bit 5 = 0, bit 6 = 0	–	375	–	mV
		data byte 5: bit 5 = 1, bit 6 = 0	–	500	–	mV
		data byte 5: bit 5 = 0, bit 6 = 1	–	625	–	mV
		data byte 5: bit 5 = 1, bit 6 = 1	–	750	–	mV
<i>Pin AMIF2IN</i>						
$V_{i(\text{IF2})}$	IF2 input voltage	AGC start level	280	380	500	mV
<i>PIN diode drive: pin IAMAGC</i>						
$I_{\text{sink(max)}}$	maximum AGC sink current	$V_o = 2.8 \text{ V}$	11	15	19	mA
$I_{\text{sink}}$	AGC sink current	FM mode	1	–	–	mA
$R_o$	output resistance	$I_o = 1 \mu\text{A}$	1	–	–	M $\Omega$
$C_o$	AM AGC current generator output capacitance		–	5	7	pF
<b>AM AGC TRANSCONDUCTANCE BUFFER: PIN AMAGCBUF; note 3</b>						
$g_{m(\text{buf})}$	buffer transconductance	AM mode; $1 \text{ V} < V_{T1\text{AMAGC}} < 4 \text{ V}$	150	166	185	$\mu\text{S}$
$I_{\text{sink(max)}}$	maximum sink current	open-collector; AM mode; $V_{T1\text{AMAGC}} = 4 \text{ V}$	450	500	560	$\mu\text{A}$
$I_{\text{source(max)}}$	maximum source current	AM mode; $V_{T1\text{AMAGC}} < 1 \text{ V}$	–	–	–30	$\mu\text{A}$
$V_{o(n)}$	buffer output noise voltage	AM mode; $V_{\text{DDA1}} - V_{\text{AMAGCBUF}} = 1 \text{ V};$ $B = 400 \text{ Hz to } 20 \text{ kHz}$	–	10	15	$\mu\text{V}$



## New In Car Entertainment (NICE) extended car radio

TEA6842H

SYMBOL	PARAMETER	CONDITIONS	MIN.	TYP.	MAX.	UNIT
AM MIXER 1 (IF1 = 10.7 MHz)						
<i>Mixer inputs: pins AMMIX1IN1 and AMMIX1IN2</i>						
$R_i$	input resistance		15	25	35	k $\Omega$
$C_i$	input capacitance		2.5	4	5.5	pF
$V_i$	DC input voltage		2.3	2.7	3.1	V
$V_{i(max)}$	maximum input voltage	1 dB compression point of AM mixer 1 output (peak-to-peak value)	500	–	–	mV
$V_{i(n)(eq)}$	equivalent input noise voltage	band limited noise; $R_{gen} = 750 \Omega$ ; $R_L = 2.8 \text{ k}\Omega$	–	5.8	8	$\frac{nV}{\sqrt{Hz}}$
<i>Mixer outputs: pins MIX1OUT1 and MIX1OUT2</i>						
$R_o$	output resistance		100	–	–	k $\Omega$
$C_o$	output capacitance		–	5	7	pF
$V_{o(max)(p-p)}$	maximum output voltage (peak-to-peak value)		12	15	–	V
$g_{m(conv)}$	conversion transconductance $\frac{I_{MIX1OUT}}{V_{AMMIX1IN}}$		2.0	2.55	3.2	$\frac{mA}{V}$
$g_{m(conv)(T)}$	conversion transconductance variation with temperature $\frac{\Delta g_{m(conv)}}{g_{m(conv)} \times \Delta T}$		–	$-9 \times 10^{-4}$	–	K $^{-1}$
IP3	3rd-order intermodulation	$R_L = 2.8 \text{ k}\Omega$ ; $\Delta f = 300 \text{ kHz}$	135	138	–	dB $\mu$ V
IP2	2nd-order intermodulation	$R_L = 2.8 \text{ k}\Omega$	–	170	–	dB $\mu$ V
F	noise figure of AM mixer 1		–	4.5	7.1	dB
$I_{bias}$	mixer bias current	AM mode	4.8	6	7.2	mA
AM MIXER 2 (IF2 = 450 kHz)						
<i>Mixer inputs: pins IFAMP1IN and IFAMP1DEC</i>						
$R_i$	input resistance		270	330	390	$\Omega$
$C_i$	input capacitance		–	5	7	pF
$V_i$	DC input voltage		2.4	2.8	3.2	V
$V_{i(max)(p)}$	maximum input voltage (peak value)	1 dB compression point of AM mixer 2 output (peak-to-peak value)	1.1	1.4	–	V

# New In Car Entertainment (NICE) extended car radio

TEA6842H

SYMBOL	PARAMETER	CONDITIONS	MIN.	TYP.	MAX.	UNIT
$V_{i(n)(eq)}$	equivalent input noise voltage	$R_{gen} = 330 \Omega$ ; $R_L = 4 \text{ k}\Omega$	–	15	22	$\frac{\text{nV}}{\sqrt{\text{Hz}}}$
<i>Mixer outputs: pins AMMIX2OUT1 and AMMIX2OUT2</i>						
$R_o$	output resistance		100	–	–	$\text{k}\Omega$
$C_o$	output capacitance		–	5	7	$\text{pF}$
$V_{o(max)(p-p)}$	maximum output voltage (peak-to-peak value)	$V_{DDA1} = 8.5 \text{ V}$	12	15	–	$\text{V}$
$g_{m(conv)}$	conversion transconductance $\frac{I_{AMMIX2OUT}}{V_{IFAMP1IN}}$		1.3	1.6	1.9	$\frac{\text{mA}}{\text{V}}$
$g_{m(conv)(T)}$	conversion transconductance variation with temperature $\frac{\Delta g_{m(conv)}}{g_{m(conv)} \times \Delta T}$		–	$-9 \times 10^{-4}$	–	$\text{K}^{-1}$
IP3	3rd-order intermodulation	$R_L = 4 \text{ k}\Omega$ ; $\Delta f = 300 \text{ kHz}$	134	137	–	$\text{dB}\mu\text{V}$
IP2	2nd-order intermodulation	$R_L = 4 \text{ k}\Omega$	–	170	–	$\text{dB}\mu\text{V}$
F	noise figure of AM mixer 2		–	16	19.5	$\text{dB}$
$I_{bias}$	mixer bias current	AM mode	3.6	4.5	5.4	$\text{mA}$
$I_L$	mixer leakage current	FM mode	–	–	50	$\mu\text{A}$
<i>IF2 AGC STAGE: PINS AMIF2IN AND AMIF2DEC</i>						
$V_{AGC(start)}$	AGC start voltage	input carrier voltage	–	14	30	$\mu\text{V}$
$V_{AGC(stop)}$	AGC stop voltage	maximum input peak voltage	1	–	–	$\text{V}$
$V_{AGC(ctrl)}$	AGC control voltage	$V_{AMIF2IN} = 1 \text{ mV}$	4.1	4.3	4.7	$\text{V}$
$\Delta\text{AGC}$	AGC range	between start and stop of AGC	–	89	–	$\text{dB}$
$R_i$	input resistance		1.8	2	2.2	$\text{k}\Omega$
$C_i$	input capacitance		–	–	5	$\text{pF}$
$V_i$	input voltage	audio attenuation $\alpha = -10 \text{ dB}$ data byte 5: bit 4 = 1; mute on data byte 5: bit 4 = 0; mute off	10 –	22 6	37 12	$\mu\text{V}$ $\mu\text{V}$
$V_{sens(rms)}$	sensitivity voltage (RMS value)	$m = 0.3$ ; $f_{mod} = 400 \text{ Hz}$ ; $B_{AF} = 2.5 \text{ kHz}$ ; $R_{source} = 2 \text{ k}\Omega$ (S+N)/N = 26 dB (S+N)/N = 46 dB	– –	45 600	65 900	$\mu\text{V}$ $\mu\text{V}$

# New In Car Entertainment (NICE) extended car radio

TEA6842H

SYMBOL	PARAMETER	CONDITIONS	MIN.	TYP.	MAX.	UNIT
AM DETECTOR OUTPUT: PIN AMAFIF2; see Fig.3						
$V_{o(min)(rms)}$	minimum AM IF2 output level (RMS value)	data byte 4: bit 0 = 1, bit 1 = 1; $m = 0$ ; $V_{AMIF2IN} = 14 \mu V$	1.5	3	4.5	mV
$V_{o(max)(rms)}$	maximum AM IF2 output level (RMS value)	data byte 4: bit 0 = 1, bit 1 = 1; $m = 0$ ; $V_{AMIF2IN} = 5 mV$	130	180	230	mV
$V_{o(rms)}$	AM AF output voltage level (RMS value)	data byte 4: bit 0 = 1, bit 1 = 0; $m = 0.3$ ; $f_{mod} = 400 Hz$ ; $V_{AMIF2IN} = 100 \mu V$ to $500 mV$ (RMS)	235	285	340	mV
$R_o$	output resistance	data byte 4: bit 0 = 1, bit 1 = 1	–	–	500	$\Omega$
$C_o$	output capacitance	data byte 4: bit 0 = 1, bit 1 = 0	–	5	7	pF
$Z_L$	load impedance	data byte 4: bit 0 = 1, bit 1 = 0	100	–	–	k $\Omega$
		data byte 4: bit 0 = 1, bit 1 = 1	10	–	–	k $\Omega$
RR	ripple rejection	$f_{ripple} = 100 Hz$ ; $V_{DDA5(ripple)} = 100 mV$ (RMS)	30	40	–	dB
AM DETECTOR; see Fig.3						
(S+N)/N	maximum signal plus noise-to-noise ratio	$m = 0.3$ ; $f_{mod} = 400 Hz$ ; $B_{AF} = 2.5 kHz$ ; $R_{source} = 2 k\Omega$	54	60	70	dB
THD	total harmonic distortion	$B_{AF} = 2.5 kHz$ ; $C_{AGC} = 22 \mu F$ ; $V_{AMIF2IN} = 100 \mu V$ to $250 mV$ (RMS)				
		$m = 0.8$ ; $f_{mod} = 400 Hz$	–	0.5	1	%
		$m = 0.9$ ; $f_{mod} = 400 Hz$	–	1	2	%
		$m = 0.8$ ; $f_{mod} = 100 Hz$	–	1.25	2.5	%
		$m = 0.9$ ; $f_{mod} = 100 Hz$	–	1.75	3.5	%
$t_{sw}$	FM to AM switching time	$V_{AMIF2IN} = 100 \mu V$ ; $C_{AGC} = 22 \mu F$	–	1000	1500	ms
$t_{st}$	AM demodulator AGC settling time	$C_{AGC} = 22 \mu F$				
		$V_{AMIF2IN} = 100 \mu V$ to $100 mV$	–	800	1200	ms
		$V_{AMIF2IN} = 100 mV$ to $100 \mu V$	–	1200	1800	ms
AM IF2 LEVEL DETECTOR: PIN $V_{level}$ ; see Fig.4						
$V_{level}$	level output DC voltage	$V_{AMIF2IN} = 10 \mu V$ to $1 V$	0	–	5	V
		$V_{AMIF2IN} < 1 \mu V$ ; standard setting of level DAA	0.1	0.35	0.8	V
		$V_{AMIF2IN} = 1.4 mV$ ; standard setting of level DAA	–	2.2	–	V
$\Delta V_{level}$	step size of starting point adjustment	standard setting of level slope	40	53	70	mV
$V_{level(slope)}$	slope of level voltage $\frac{\Delta V_{level}}{\Delta V_{AMIF2IN}}$	$V_{AMIF2IN} = 140 \mu V$ to $140 mV$ ; standard setting of level slope	800	1000	1200	$\frac{mV}{20 dB}$

# New In Car Entertainment (NICE) extended car radio

TEA6842H

SYMBOL	PARAMETER	CONDITIONS	MIN.	TYP.	MAX.	UNIT
$\Delta V_{\text{step}}$	step size of slope adjustment	$V_{\text{AMIF2IN}} = 1.4 \text{ mV}$	55	75	95	$\frac{\text{mV}}{20 \text{ dB}}$
$B_{\text{level}}$	bandwidth of level output voltage		200	300	–	kHz
$R_o$	output resistance		–	–	500	$\Omega$
RR	ripple rejection $\frac{V_{\text{level}}}{V_{\text{DDA6}}}$	$f_{\text{ripple}} = 100 \text{ Hz};$ $V_{\text{DDA6(ripple)}} = 100 \text{ mV (RMS)}$	–	40	–	dB
AM NOISE BLANKER; see Fig.5						
<i>Threshold: pin AMNBHOLD</i>						
$V_o$	DC output voltage		4.4	4.75	5.25	V
$t_{\text{sup}}$	suppression time		6	7.5	10	$\mu\text{s}$
$f_{\text{trigger}}$	trigger sensitivity	$V_{\text{pulse}} = 200 \text{ mV}; V_{\text{level}} < 1.8 \text{ V}$	–	1000	–	Hz
		$V_{\text{pulse}} = 200 \text{ mV}; V_{\text{level}} > 2.2 \text{ V}$	–	–	100	Hz
		$V_{\text{pulse}} = 20 \text{ mV}; V_{\text{level}} < 1.8 \text{ V}$	–	–	100	Hz
<i>Noise detector output: pin TRDSMUTE</i>						
$I_{\text{sink(AGC)}}$	AM noise blanker AGC sink current	$V_{\text{TRDSMUTE}} = 3 \text{ V}$	30	45	60	$\mu\text{A}$
$V_{\text{AGC}}$	AM noise blanker AGC voltage	AM mixer 1 input $V_i = 0 \text{ V}$	2.1	2.45	2.85	V
<b>FM signal channel</b>						
RF AGC (FM DISTANCE MODE)						
<i>FM mixer inputs: pins FMMIXIN1 and FMMIXIN2</i>						
$V_{i(\text{RF})(\text{rms})}$	RF input voltage for start of wideband AGC (RMS value)	data byte 5: bit 5 = 1, bit 6 = 1	–	4	–	mV
		data byte 5: bit 5 = 0, bit 6 = 1	–	8	–	mV
		data byte 5: bit 5 = 1, bit 6 = 0	–	12	–	mV
		data byte 5: bit 5 = 0, bit 6 = 0	–	16	–	mV
<i>AGC control: pin T2FMAGC</i>						
$R_{\text{source}}$	source resistance		4	5	6	$\text{k}\Omega$
$V_{o(\text{ref})}$	DC output reference voltage	data byte 5: bit 5 = 0, bit 6 = 0; $V_{\text{FMMIXIN1-FMMIXIN2}} = 0 \text{ V}$	3.8	4.1	4.4	V
<i>PIN diode drive output: pin IFMAGC</i>						
$I_{\text{sink(AGC)(max)}}$	maximum AGC sink current	$V_{\text{IFMAGC}} = 2.5 \text{ V};$ $V_{\text{T2FMAGC}} = V_{o(\text{ref})} - 0.5 \text{ V};$ data byte 5: bit 5 = 0, bit 6 = 0, bit 7 = 0; data byte 4: bit 1 = 0	8	10.5	14	mA
$I_{\text{source(AGC)(max)}}$	maximum AGC source current	$V_{\text{IFMAGC}} = 2.5 \text{ V};$ $V_{\text{T2FMAGC}} = V_{o(\text{ref})} + 0.5 \text{ V};$ data byte 5: bit 5 = 0, bit 6 = 0, bit 7 = 0; data byte 4: bit 1 = 0	–14	–10.5	–8	mA

# New In Car Entertainment (NICE) extended car radio

TEA6842H

SYMBOL	PARAMETER	CONDITIONS	MIN.	TYP.	MAX.	UNIT
$I_{\text{source(AGC)}}$	AGC source current	AM mode	-19	-14	-10	mA
		$V_{\text{IFMAGC}} = 2.5 \text{ V}$ ; data byte 4: bit 0 = 0, bit 1 = 1, bit 2 = 0 (FM local)	-4.4	-3.7	-2.7	mA
<i>Level voltage: pin <math>V_{\text{level}}</math></i>						
$V_{\text{th}}$	threshold voltage for narrow-band AGC	data byte 5: bit 5 = 0, bit 6 = 0, bit 7 = 1	600	750	900	mV
FM RF MIXER						
<i>FM mixer inputs: pins FMMIXIN1 and FMMIXIN2</i>						
$V_{\text{i(RF)(max)}}$	maximum RF input voltage	1 dB compression point of FM mixer output voltage (peak-to-peak value)	70	140	–	mV
$V_{\text{i(n)(eq)}}$	equivalent input noise voltage	$R_{\text{gen}} = 200 \Omega$ ; $R_{\text{L}} = 2.8 \text{ k}\Omega$	–	2.6	3.1	$\frac{\text{nV}}{\sqrt{\text{Hz}}}$
$R_{\text{i}}$	input resistance		1.4	2.8	4.2	$\text{k}\Omega$
$C_{\text{i}}$	input capacitance		–	5	7	pF
<i>FM mixer outputs: pins MIX1OUT1 and MIX1OUT2</i>						
$R_{\text{o}}$	output resistance		100	–	–	$\text{k}\Omega$
$C_{\text{o}}$	output capacitance		2	3.5	5	pF
$I_{\text{bias}}$	mixer bias current	FM mode	4.8	6	7.2	mA
$V_{\text{o(max)(p-p)}}$	maximum output voltage (peak-to-peak value)		3	–	–	V
<i>FM mixer reference voltage: pin <math>V_{\text{ref(FMMIX)}}</math></i>						
$V_{\text{ref}}$	reference voltage	FM mode	6.5	7.1	7.9	V
		AM mode	2.7	3.1	3.4	V
<i>FM mixer</i>						
$g_{\text{m(conv)}}$	conversion transconductance $\frac{I_{\text{MIX1OUT}}}{V_{\text{FMMIXIN}}}$		8.5	13	18	$\frac{\text{mA}}{\text{V}}$
$g_{\text{m(conv)(T)}}$	conversion transconductance variation with temperature $\frac{\Delta g_{\text{m(conv)}}}{g_{\text{m(conv)}} \times \Delta T}$		–	$-1 \times 10^{-3}$	–	$\text{K}^{-1}$
F	noise figure		–	3	4.6	dB
$R_{\text{gen(opt)}}$	optimum generator resistance		180	240	300	$\Omega$

## New In Car Entertainment (NICE) extended car radio

TEA6842H

SYMBOL	PARAMETER	CONDITIONS	MIN.	TYP.	MAX.	UNIT
IP3	3rd-order intermodulation		116	119	–	dB $\mu$ V
IRR	image rejection ratio $\frac{V_{\text{MIX1OUTwanted}}}{V_{\text{MIX1OUTimage}}}$	$f_{\text{RFwanted}} = 87.5 \text{ MHz};$ $f_{\text{RFimage}} = 108.9 \text{ MHz}$	25	30	–	dB
		data byte 4 = X010X110; $f_{\text{RFwanted}} = 162.475 \text{ MHz};$ $f_{\text{RFimage}} = 183.875 \text{ MHz};$ weather band mode	22	30	–	dB
<b>IF AMPLIFIER 1</b>						
G	gain $\frac{V_{\text{IFAMP1OUT}}}{V_{\text{IFAMP1IN}}}$	$R_L = 330 \Omega; V_{\text{IFAMP1IN}} = 1 \text{ mV}$	8.5	10.5	12.5	dB
F	noise figure		–	10	13	dB
IP3	3rd-order intermodulation		117	120	–	dB $\mu$ V
<i>Inputs: pins IFAMP1IN and IFAMP1DEC</i>						
$V_{i(\text{max})(\text{p})}$	maximum input voltage (peak value)	1 dB compression point of IF amplifier 1 output voltage (peak value)	250	–	–	mV
$V_{i(\text{n})(\text{eq})}$	equivalent input noise voltage	$R_{\text{gen}} = 330 \Omega; R_L = 330 \Omega$	–	8	10	$\frac{\text{nV}}{\sqrt{\text{Hz}}}$
$R_i$	input resistance		270	330	390	$\Omega$
$C_i$	input capacitance		–	5	7	pF
<i>Output: pin IFAMP1OUT</i>						
$V_{o(\text{max})(\text{p})}$	maximum output voltage (peak value)		1.2	1.5	–	V
$R_o$	output resistance		270	330	390	$\Omega$
$C_o$	output capacitance		–	5	7	pF
<b>IF AMPLIFIER 2</b>						
G	gain $\frac{V_{\text{IFAMP2OUT}}}{V_{\text{IFAMP2IN}}}$	$R_L = 330 \Omega; V_{\text{IFAMP2IN}} = 1 \text{ mV}$	6.5	8.5	10.5	dB
F	noise figure		–	13	15	dB
IP3	3rd-order intermodulation		127	130	–	dB $\mu$ V
<i>Inputs: pins IFAMP2IN and IFAMP2DEC</i>						
$V_{i(\text{max})(\text{p})}$	maximum input voltage (peak value)	1 dB compression point of IF amplifier 2 output voltage (peak value)	500	–	–	mV
$V_{i(\text{n})(\text{eq})}$	equivalent input noise voltage	$R_{\text{gen}} = 330 \Omega; R_L = 330 \Omega$	–	10	13	$\frac{\text{nV}}{\sqrt{\text{Hz}}}$

## New In Car Entertainment (NICE) extended car radio

TEA6842H

SYMBOL	PARAMETER	CONDITIONS	MIN.	TYP.	MAX.	UNIT
$R_i$	input resistance		270	330	390	$\Omega$
$C_i$	input capacitance		–	5	7	pF
<i>Output: pin IFAMP2OUT</i>						
$V_{o(max)(p)}$	maximum output voltage (peak value)		1.2	1.5	–	V
$R_o$	output resistance		270	330	390	$\Omega$
$C_o$	output capacitance		–	5	7	pF
<b>FM demodulator and level detector; see Figs 6 and 7</b>						
FM DEMODULATOR						
<i>FM limiter inputs: pins FMLIMIN and FMLIMDEC</i>						
$R_i$	input resistance		10	12	14	k $\Omega$
$C_i$	input capacitance		–	5	7	pF
$V_{start(lim)(rms)}$	start of limiting of RDS MPX output voltage (RMS value)	$\alpha_{AF} = -3$ dB; $R_{gen} = 165 \Omega$	–	10	15	$\mu$ V
$V_{o(sens)(rms)}$	sensitivity for RDS MPX output voltage (RMS value)	$\Delta f = 22.5$ kHz; $f_{mod} = 1$ kHz; de-emphasis = 75 $\mu$ s $R_{gen} = 165 \Omega$ ; (S+N)/N = 26 dB (S+N)/N = 46 dB	–	10	15	$\mu$ V
$V_{start(lim)(rms)}$	start of limiting of FM MPX output voltage (RMS value)	$\alpha_{AF} = -3$ dB; $R_{gen} = 165 \Omega$	–	10	15	$\mu$ V
$V_{o(sens)(rms)}$	sensitivity for FM MPX output voltage (RMS value)	$\Delta f = 22.5$ kHz; $f_{mod} = 1$ kHz; de-emphasis = 75 $\mu$ s $R_{gen} = 165 \Omega$ ; (S+N)/N = 26 dB (S+N)/N = 46 dB	–	10	15	$\mu$ V
<i>RDS MPX output: pin RDSMPX</i>						
$V_{o(rms)}$	RDS MPX output voltage (RMS value)	$V_{FMLIMIN} = 20 \mu$ V to 1 V $\Delta f = 5$ kHz; $f_{mod} = 57$ kHz $\Delta f = 22.5$ kHz; $f_{mod} = 1$ kHz	40 180	50 230	60 280	mV mV
(S+N)/N	maximum signal plus noise-to-noise ratio	$\Delta f = 22.5$ kHz; $f_{mod} = 1$ kHz; de-emphasis = 75 $\mu$ s; $V_{FMLIMIN} = 10$ mV	70	73	–	dB
THD	total harmonic distortion	$\Delta f = 75$ kHz; $f_{mod} = 1$ kHz; de-emphasis = 75 $\mu$ s; $V_{FMLIMIN} = 200 \mu$ V to 800 mV	–	0.4	0.75	%

# New In Car Entertainment (NICE) extended car radio

TEA6842H

SYMBOL	PARAMETER	CONDITIONS	MIN.	TYP.	MAX.	UNIT
$\alpha_{AM}$	AM suppression $\frac{V_{o(rms)}}{V_{o(AM)(rms)}}$	FM: $\Delta f = 22.5$ kHz; $f_{mod} = 1$ kHz; AM: $m = 0.3$ ; $f_{mod} = 1$ kHz; de-emphasis = 75 $\mu$ s $V_{FMLIMIN} = 30$ to 70 $\mu$ V	20	30	–	dB
		$V_{FMLIMIN} = 70$ to 500 $\mu$ V	30	40	–	dB
		$V_{FMLIMIN} = 500$ $\mu$ V to 300 mV	50	60	–	dB
		$V_{FMLIMIN} = 300$ mV to 1 V	30	40	–	dB
$I_{o(max)}$	maximum output current		–	–	100	$\mu$ A
$R_o$	output resistance		–	–	500	$\Omega$
$R_L$	load resistance		20	–	–	k $\Omega$
$C_L$	load capacitance		–	–	50	pF
B	bandwidth	$C_L = 0$ ; $R_L > 20$ k $\Omega$	200	300	–	kHz
PSRR	power supply ripple rejection	$f_{ripple} = 100$ Hz to 20 kHz	–	40	–	dB
<i>FM MPX output: pin FMMPX</i>						
$V_{o(rms)}$	FM MPX output voltage (RMS value)	$\Delta f = 22.5$ kHz; $f_{mod} = 1$ kHz; $V_{FMLIMIN} = 20$ $\mu$ V to 1 V	180	230	280	mV
		data byte 4 = X010X110; $\Delta f = 1.5$ kHz; $f_{mod} = 1$ kHz; $V_{FMLIMIN} = 20$ $\mu$ V to 1 V; weather band mode	150	230	310	mV
(S+N)/N	maximum signal plus noise-to-noise ratio	$\Delta f = 22.5$ kHz; $f_{mod} = 1$ kHz; de-emphasis = 75 $\mu$ s; $V_{FMLIMIN} = 10$ mV	66	70	–	dB
THD	total harmonic distortion	$\Delta f = 75$ kHz; $f_{mod} = 1$ kHz; de-emphasis = 75 $\mu$ s; $V_{FMLIMIN} = 200$ $\mu$ V to 800 mV	–	0.4	0.75	%
$\alpha_{AM}$	AM suppression $\frac{V_{o(rms)}}{V_{o(AM)(rms)}}$	FM: $\Delta f = 22.5$ kHz; $f_{mod} = 1$ kHz; AM: $m = 0.3$ ; $f_{mod} = 1$ kHz; de-emphasis = 75 $\mu$ s $V_{FMLIMIN} = 30$ to 70 $\mu$ V	20	30	–	dB
		$V_{FMLIMIN} = 70$ to 500 $\mu$ V	30	40	–	dB
		$V_{FMLIMIN} = 500$ $\mu$ V to 300 mV	50	60	–	dB
		$V_{FMLIMIN} = 300$ mV to 1 V	30	40	–	dB
$I_{o(max)}$	maximum output current		–	–	100	$\mu$ A
$R_{o(max)}$	maximum output resistance		–	–	500	$\Omega$
$R_{L(min)}$	minimum load resistance		20	–	–	k $\Omega$
$C_{L(max)}$	maximum load capacitance		–	–	50	pF
B	bandwidth	$C_L = 0$ ; $R_L > 20$ k $\Omega$	200	–	–	kHz



# New In Car Entertainment (NICE) extended car radio

TEA6842H

SYMBOL	PARAMETER	CONDITIONS	MIN.	TYP.	MAX.	UNIT
PSRR	power supply ripple rejection	$f_{\text{ripple}} = 100 \text{ Hz to } 20 \text{ kHz}$	–	40	–	dB
$t_{\text{sw}}$	AM to FM switching time	$V_{\text{FMLIMIN}} = 100 \mu\text{V}$	–	100	150	ms
<b>FM MPX SOFT MUTE</b>						
<i>Soft mute</i>						
$\alpha_{\text{mute}}$	mute attenuation	$V_{\text{FMLIMIN}} = 10 \text{ mV};$ $V_{\text{TMUTE}} = 300 \text{ mV}$ data byte 7 = XX000100 data byte 7 = XX001100 data byte 7 = XX010100 data byte 7 = XX011100 data byte 7 = XX100100 data byte 7 = XX101100 data byte 7 = XX110100 data byte 7 = XX111100	–	7 8 9.5 11 14 18 25 39	–	dB dB dB dB dB dB dB dB
$\alpha_{\text{mute(off)}}$	mute off	$V_{\text{FMLIMIN}} = 10 \text{ mV};$ $V_{\text{TMUTE}} = 300 \text{ mV};$ data byte 7 = XXXXX111	–1	0	+1	dB
$V_{\text{offset(DC)}}$	DC offset created by soft mute on pin FMMPX $\Delta V = V_{\text{muted}} - V_{\text{notmuted}}$		–150	–	+150	mV
<i>Input: pin TMUTE</i>						
$V_{\text{TMUTE}}$	mute voltage	$V_{\text{FMLIMIN}} = 0 \text{ to } 1 \text{ V}$	0	–	5	V
$V_{\text{offset}}$	voltage offset with $V_{\text{level}}$	$V_{\text{FMLIMIN}} = 0 \text{ to } 1 \text{ V}$	–200	–	+200	mV
$I_{\text{dch}}$	discharge current	$V_{\text{level}} < V_{\text{TMUTE}}$	2.5	3.5	4.5	$\mu\text{A}$
$I_{\text{ch}}$	charge current	$V_{\text{level}} > V_{\text{TMUTE}}$	–4.5	–3.5	–2.5	$\mu\text{A}$
$V_{\text{TMUTE(start)}}$	mute start voltage	$\alpha_{\text{mute}} = 3 \text{ dB}; V_{\text{FMLIMIN}} = 10 \text{ mV}$ data byte 7 = XX111000 data byte 7 = XX111001 data byte 7 = XX111010 data byte 7 = XX111011 data byte 7 = XX111100 data byte 7 = XX111101 data byte 7 = XX111110	300 400 450 520 580 640 680	450 550 630 720 800 890 980	600 700 810 920 1020 1140 1280	mV mV mV mV mV mV mV
<i>Output: pin <math>V_{\text{level}}</math></i>						
$R_o$	output resistance of level output		–	–	500	$\Omega$
RR	ripple rejection of level output	$f_{\text{ripple}} = 100 \text{ Hz};$ $V_{\text{DDA1(ripple)}} = 100 \text{ mV (RMS)}$	–	40	–	dB

# New In Car Entertainment (NICE) extended car radio

TEA6842H

SYMBOL	PARAMETER	CONDITIONS	MIN.	TYP.	MAX.	UNIT
<b>RDS update;</b> see Figs 11 and 12						
<i>RDS mute</i>						
$\alpha_{\text{mute}}$	muting depth	data byte 3: bit 7 = 1 (mute)	60	80	–	dB
$V_{\text{offset(DC)}}$	DC offset during RDS update mute pin FMMPX $\Delta V = V_{\text{muted}} - V_{\text{notmuted}}$		–30	–	+30	mV
<i>Capacitor: pin TRDSMUTE</i>						
$V_{\text{TRDSMUTE}}$	voltage at pin TRDSMUTE	no mute	–	5.7	–	V
		mute	–	1.1	–	V
$I_{\text{dch}}$	discharge current	$V_o = 3 \text{ V}$ ; data byte 3: bit 7 = 1	24	32	38	$\mu\text{A}$
$I_{\text{ch}}$	charge current	$V_o = 3 \text{ V}$ ; data byte 3: bit 7 = 0	–38	–32	–24	$\mu\text{A}$
$I_{\text{LI}}$	input leakage current	mute	–10	–	+10	nA
<i>Output: pin AFHOLD</i>						
$I_{\text{sink(max)}}$	maximum sink current	after first bus transmission with data byte 1: bit 7 = 1 (start of RDS update); $V_o = 0.5 \text{ V}$	1.0	1.2	1.4	mA
<i>Output: pin AFSAMPLE</i>						
$I_{\text{sink(max)}}$	maximum sink current	no RDS update in progress; $V_o = 0.5 \text{ V}$	1.0	1.2	1.4	mA
<b>MPX mute input: pin MUTE</b>						
$V_{\text{mute}}$	mute voltage	mute	–	–	1.5	V
		no mute	3	–	–	V
$I_{\text{source}}$	source current	$V_o = 0 \text{ to } 5 \text{ V}$	–30	–50	–70	$\mu\text{A}$
$R_i$	input resistance		100	–	–	k $\Omega$
<b>Demodulator AFC</b>						
OUTPUT: PIN RDSMPX						
$G_{\text{AFC}}$	AFC gain on $V_{\text{RDSMPX}}$ $\frac{\Delta V_{o(\text{AFC})(\text{disabled})}}{\Delta V_{o(\text{AFC})(\text{enabled})}}$	detuning $\Delta f = 100 \text{ kHz}$ ; $V_{\text{FMLIMIN}} = 1 \text{ mV}$	28	32	–	dB
$V_{\text{offset(DC)}}$	residual DC offset	$L_{\text{demod}} = \text{typical value}$ $V_{\text{FMLIMIN}} = 10 \text{ to } 80 \mu\text{V}$	–	0.1	1	V
		$V_{\text{FMLIMIN}} = 80 \mu\text{V to } 800 \text{ mV}$	–	10	30	mV
		$L_{\text{demod}} = \pm 6\%$ $V_{\text{FMLIMIN}} = 10 \text{ to } 80 \mu\text{V}$	–	0.240	1	V
		$V_{\text{FMLIMIN}} = 80 \mu\text{V to } 800 \text{ mV}$	–	25	500	mV

## New In Car Entertainment (NICE) extended car radio

TEA6842H

SYMBOL	PARAMETER	CONDITIONS	MIN.	TYP.	MAX.	UNIT
CAPACITOR: PIN C <sub>AFC</sub>						
I <sub>dch</sub>	AFC time constant discharge current	V <sub>i</sub> = 1.4 to 4.1 V	90	120	150	μA
I <sub>ch</sub>	AFC time constant charge current	V <sub>i</sub> = 1.4 to 4.1 V	-150	-120	-90	μA
<b>FM IF level detector: pin V<sub>level</sub></b>						
V <sub>level</sub>	level output DC voltage	V <sub>FMLIMIN</sub> = 10 μV to 1 V	0	–	5	V
		V <sub>FMLIMIN</sub> < 1 μV; standard setting of level DAA	0.1	0.35	0.8	V
		V <sub>FMLIMIN</sub> = 1 mV; standard setting of level DAA	1.4	2	2.4	V
ΔV <sub>level</sub>	step size of level starting point adjustment	standard setting of level slope; V <sub>FMLIMIN</sub> = 1 to 300 mV	40	53	70	mV
V <sub>level(slope)</sub>	slope of level voltage $\frac{\Delta V_{level}}{\Delta V_{FMLIMIN}}$	standard setting of level slope	800	1000	1200	$\frac{mV}{20 dB}$
ΔV <sub>step</sub>	level slope adjust step size	V <sub>FMLIMIN</sub> = 1 mV	55	75	95	$\frac{mV}{20 dB}$
ΔV <sub>level(T)</sub>	level voltage variation with temperature $\frac{\Delta V_{level}}{V_{level} \times \Delta T}$	V <sub>FMLIMIN</sub> = 1 mV	-10 <sup>-3</sup>	–	+10 <sup>-3</sup>	K <sup>-1</sup>
B <sub>level</sub>	bandwidth of level output voltage	V <sub>FMLIMIN</sub> = 10 mV; standard setting of DAA	200	300	–	kHz
I <sub>source</sub>	output source current		–	–	-300	μA
I <sub>sink</sub>	output sink current		50	–	–	μA
R <sub>o</sub>	output resistance		–	–	500	Ω
RR	ripple rejection	f <sub>ripple</sub> = 100 Hz; V <sub>DDA1(ripple)</sub> = 100 mV (RMS)	–	40	–	dB
<b>Weather band mode</b>						
WEATHER BAND FLAG: PIN T1AMAGC						
I <sub>L(max)</sub>	maximum load current		-5	–	+5	μA
V <sub>o(FM)(max)</sub>	maximum output voltage for FM mode		0	–	0.5	V
V <sub>o(WB)</sub>	output voltage for weather band mode		5.1	6	6.9	V

# New In Car Entertainment (NICE) extended car radio

TEA6842H

SYMBOL	PARAMETER	CONDITIONS	MIN.	TYP.	MAX.	UNIT
<b>WEATHER BAND SWITCH OUTPUT: PIN WBSW</b>						
$I_{L(max)}$	maximum load current		-1000	-	-	$\mu A$
$R_{i(shunt)}$	internal shunt resistance to ground		-	-	50	$k\Omega$
$V_{o(FM)(max)}$	maximum output voltage for FM mode		0	-	0.35	V
$V_{o(WB)}$	output voltage for weather band mode		4	-	5	V
<b>Ultrasonic noise detector</b>						
$G_{ctrl}$	gain control $\frac{\Delta G_{USN}}{\Delta R_{USNSENS}}$	$f_{mod} = 750 \text{ kHz}; V_{TMUTE} = 2.5 \text{ V}$	0.09	0.12	0.15	$\frac{dB}{k\Omega}$
$\alpha_{50}$	50 kHz attenuation of input filter	$f_{mod} = 50 \text{ kHz};$ $R_{USNSENS} = 82 \text{ k}\Omega;$ $V_{RDSMPX(AC)} = 90 \text{ mV (RMS)}$	60	-	-	dB
<b>SENSITIVITY CONTROL: PIN USNSENS</b>						
$I_{ctrl(source)}$	ultrasonic noise detector sensitivity control pin source current	$R_{USNSENS} < 162 \text{ k}\Omega$	-39	-33	-27	$\mu A$
<b>OUTPUT: PIN TUSN</b>						
$f_{mod}$	3 dB frequency ultrasonic noise detector input filter	$C_{TUSN} < 10 \text{ pF}$	300	450	600	kHz
$I_{att}$	peak detector attack current	$f_{mod} = 750 \text{ kHz}; V_{TUSN} = 1 \text{ V};$ $V_{RDSMPX(AC)} = 90 \text{ mV (RMS)};$ $R_{USNSENS} = 82 \text{ k}\Omega$	30	37	44	$\mu A$
$I_{dec}$	peak detector decay current	$V_{TUSN} = 4 \text{ V}; V_{RDSMPX(AC)} = 0 \text{ V};$ $R_{USNSENS} = 82 \text{ k}\Omega$	-14	-11	-8	$\mu A$
$V_o$	peak detector output voltage	FM mode; $R_{USNSENS} = 82 \text{ k}\Omega$ $V_{RDSMPX(AC)} = 0 \text{ V}$ $V_{RDSMPX(AC)} = 90 \text{ mV (RMS)};$ $f_{mod} = 750 \text{ kHz}$	4.5 0	5.0 -	5.5 1.5	V V
<b>BUFFERED OUTPUT: PIN USNBUF</b>						
$G$	gain $20 \log \frac{\Delta V_{USNBUF(DC)}}{\Delta V_{RDSMPX(AC)}}$	$f_{mod} = 750 \text{ kHz};$ $R_{USNSENS} = 82 \text{ k}\Omega$ $V_{TMUTE} = 700 \text{ mV}$ $V_{TMUTE} = 2.5 \text{ V}$ $V_{TMUTE} = 4 \text{ V}$	17 34 44	20 39 50	23 44 56	dB dB dB
$V_{o(max)}$	maximum output voltage	$V_{RDSMPX(AC)} = 0 \text{ V};$ $R_{USNSENS} = 82 \text{ k}\Omega$	4.5	4.75	5.0	V

## New In Car Entertainment (NICE) extended car radio

TEA6842H

SYMBOL	PARAMETER	CONDITIONS	MIN.	TYP.	MAX.	UNIT
$V_{o(\min)}$	minimum output voltage	$f_{\text{mod}} = 750 \text{ kHz}$ ; $R_{\text{USNSENS}} = 82 \text{ k}\Omega$ $V_{\text{RDSMPX(AC)}} = 90 \text{ mV (RMS)}$ $V_{\text{RDSMPX(AC)}} = 120 \text{ mV (RMS)}$	– –	– –	1.5 0.5	V V
$V_{o(\text{buf})}$	buffer output voltage	FM mode; $R_{\text{USNSENS}} = 82 \text{ k}\Omega$ $V_{\text{RDSMPX(AC)}} = 0 \text{ V}$ $V_{\text{RDSMPX(AC)}} = 90 \text{ mV (RMS)}$ ; $f_{\text{mod}} = 750 \text{ kHz}$	4.5 –	4.75 –	5.0 1.5	V V
$I_{\text{source(max)}}$	maximum source current	FM mode; $V_{\text{TUSN}} = 2.5 \text{ V}$ ; $V_{\text{USNBUF}} = 1.5 \text{ V}$	–1500	–1000	–800	$\mu\text{A}$
$I_{\text{sink(max)}}$	maximum sink current	FM mode; $V_{\text{TUSN}} = 2.5 \text{ V}$ ; $V_{\text{USNBUF}} = 3.5 \text{ V}$	200	300	450	$\mu\text{A}$
$V_{o(n)(\text{buf})}$	buffer output noise voltage	FM mode; $B = 400 \text{ Hz to } 20 \text{ kHz}$	–	–	500	$\mu\text{V}$
RR	buffer ripple rejection	FM mode; $f_{\text{ripple}} = 100 \text{ Hz}$ ; related to $V_{\text{DDA6}}$	34	40	–	dB
$V_{\text{offset}(\text{buf})}$	buffer offset voltage	FM mode; $ I_{\text{USNBUF}}  < 100 \mu\text{A}$ ; $V_{\text{TUSN}} = 2.5 \text{ V}$	–	50	100	mV
$R_o$	output resistance		150	200	250	$\Omega$
$C_{L(\text{max})}$	maximum load capacitance		–	–	100	pF

### Notes

- DAA conversion gain formula:  $V_{\text{DAAOUT}} = \left[ 2 \times \left( 0.75 \times \frac{n}{128} + 0.25 \right) \times (V_{\text{DAAIN}} + V_{\text{DAATD}}) \right] - V_{\text{DAATD}}$ ; where  $n = 0$  to 127.
- Pin FREF:  $R_{\text{ext}} = 68 \text{ k}\Omega$  connected to ground activates the 2nd I<sup>2</sup>C-bus address.
- The AM AGC transconductance buffer delivers a sink current which is proportional to the voltage at pin T1AMAGC.

New In Car Entertainment (NICE)  
extended car radio

TEA6842H

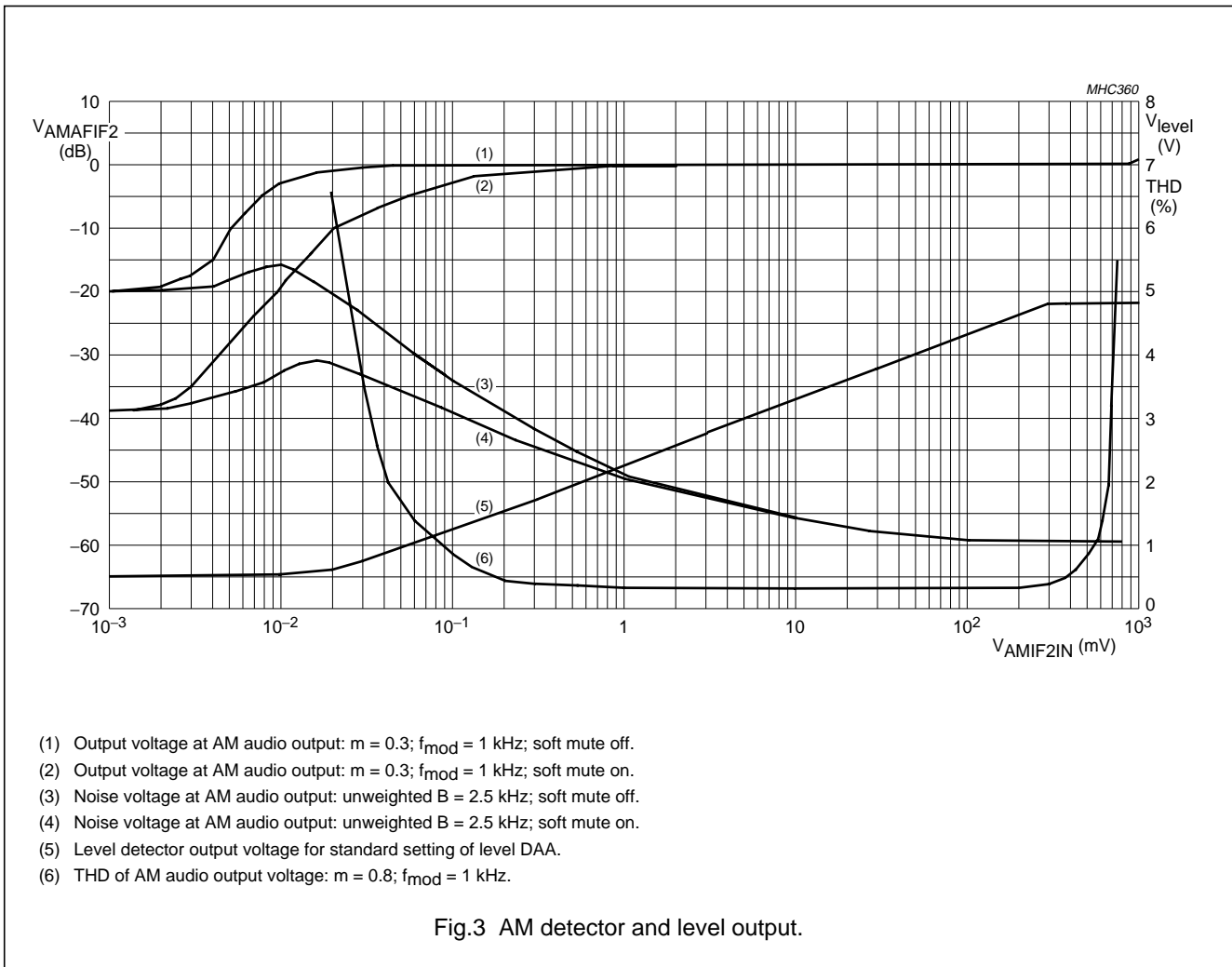

New In Car Entertainment (NICE)  
extended car radio

TEA6842H

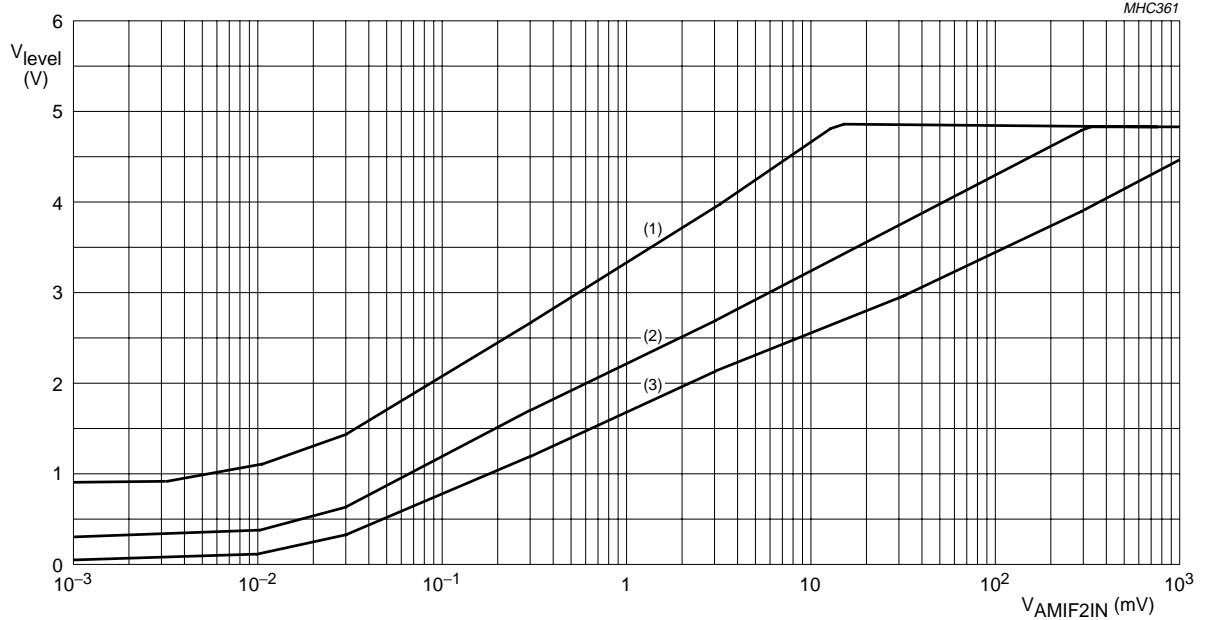

- (1) Level DAA setting byte 6 = FFH.
- (2) Level DAA setting byte 6 = 84H (standard setting).
- (3) Level DAA setting byte 6 = 00H.

Fig.4 AM level voltage.

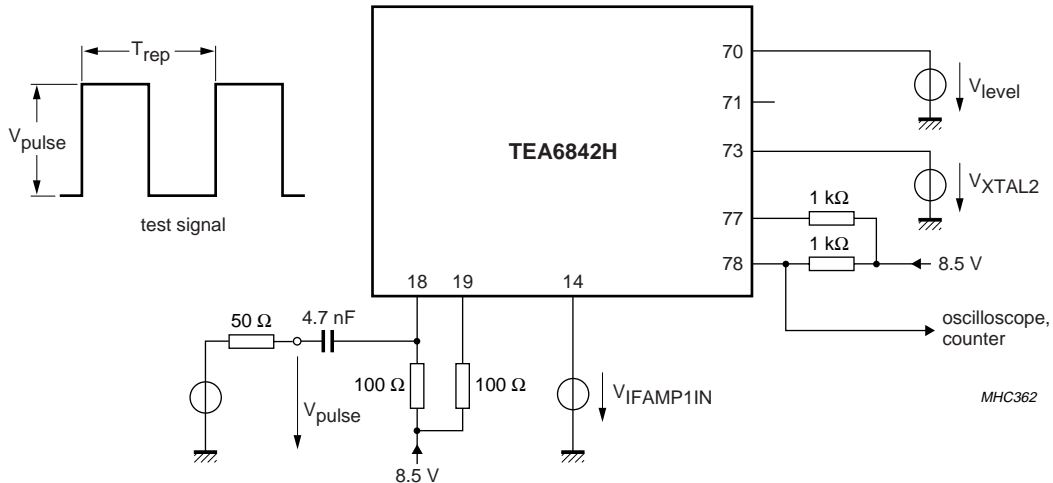

Test signal:  $T_{rep} = 2 \text{ ms}$ ,  $t_r < 50 \text{ ns}$ ,  $t_f < 50 \text{ ns}$  and duty factor 50%.

$V_{IFAMP1IN} = 4 \text{ V}$ .  
 $V_{XTAL2} = 3 \text{ V}$ .

Fig.5 Test circuit for AM noise blanker.

New In Car Entertainment (NICE)  
extended car radio

TEA6842H

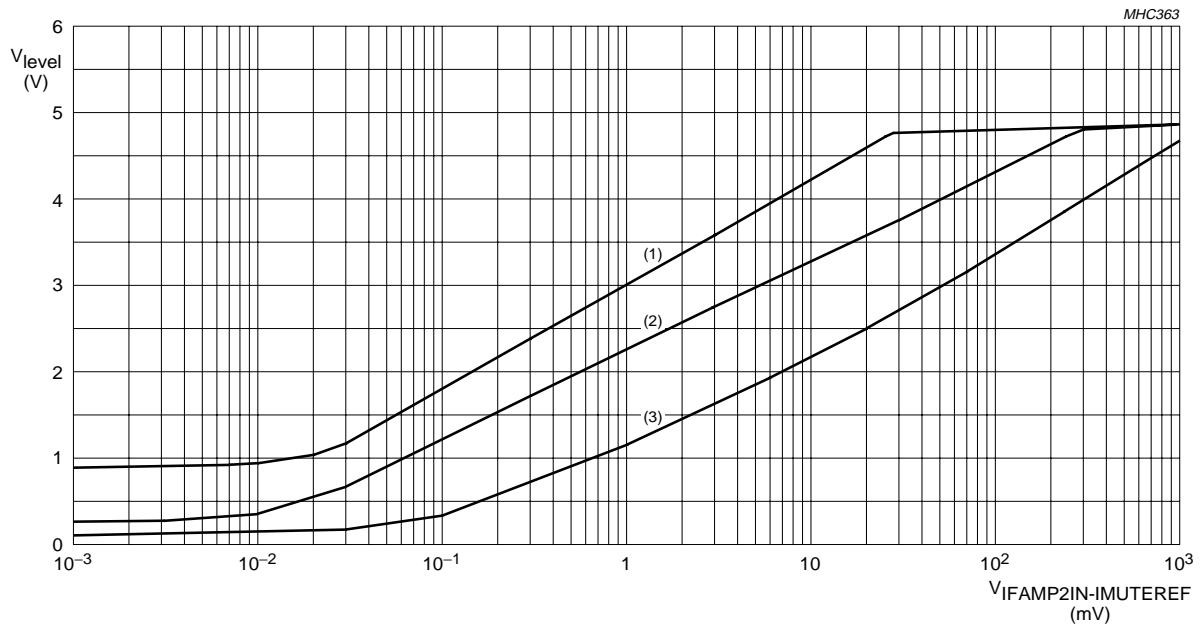

- (1) Level DAA setting byte 6 = FFH.
- (2) Level DAA setting byte 6 = 84H (standard setting).
- (3) Level DAA setting byte 6 = 00H.

Fig.6 FM level voltage.



New In Car Entertainment (NICE)  
extended car radio

TEA6842H

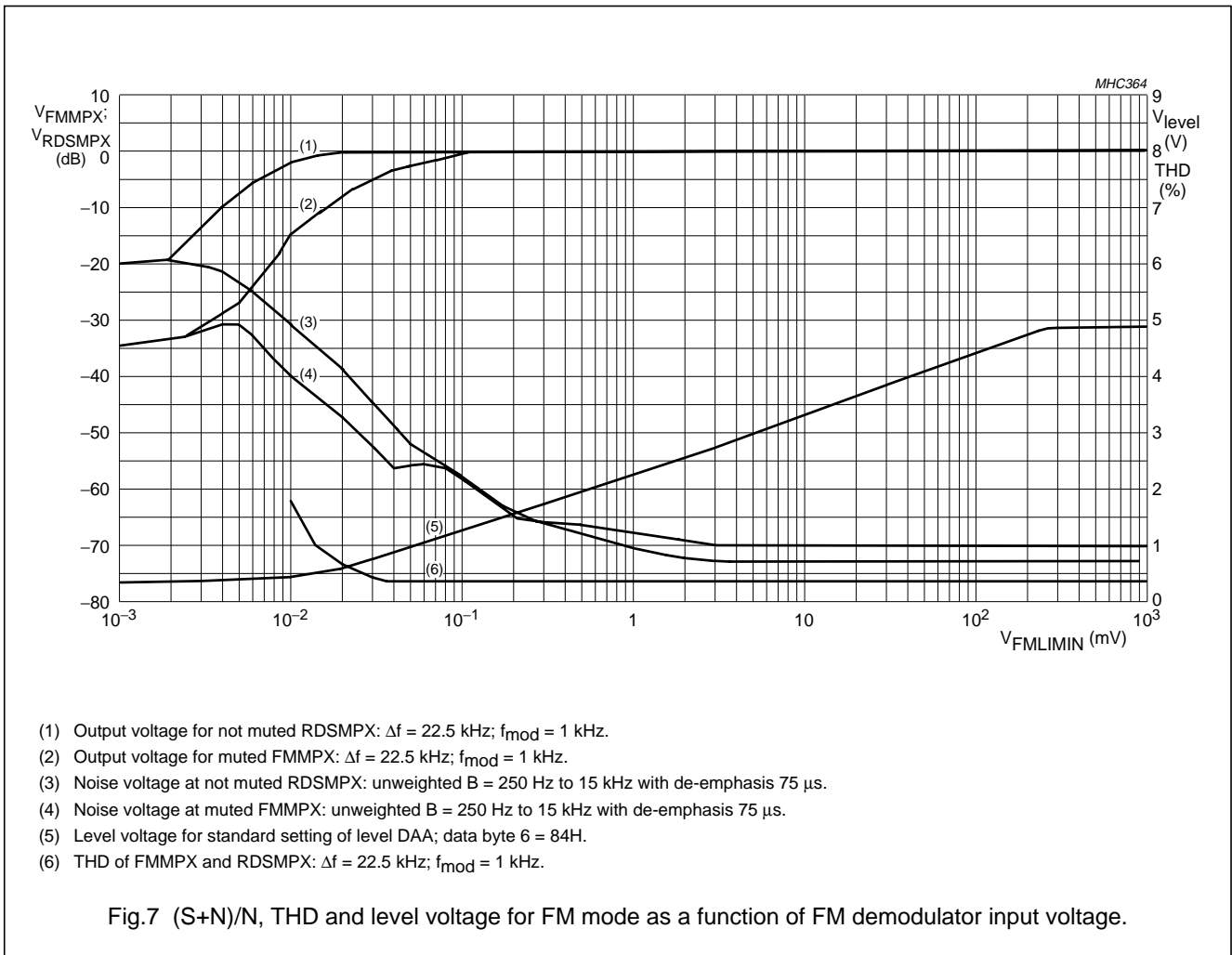

# New In Car Entertainment (NICE) extended car radio

TEA6842H

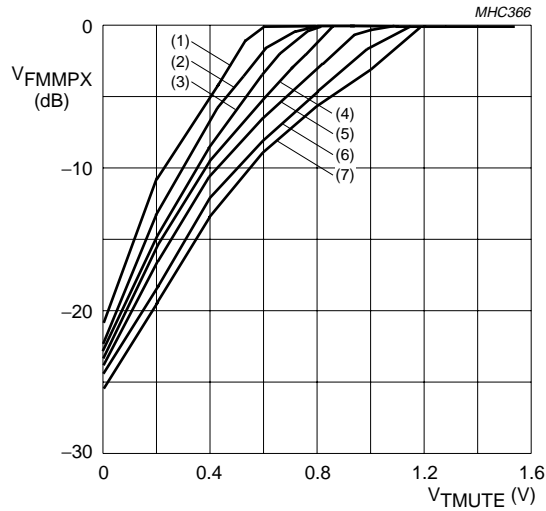

Mute start:

- (1) MD[2:0] = 000.
- (2) MD[2:0] = 001.
- (3) MD[2:0] = 010.
- (4) MD[2:0] = 011.
- (5) MD[2:0] = 100.
- (6) MD[2:0] = 101.
- (7) MD[2:0] = 110.

Mute start adjustment range, mute slope = 100 and  $V_{FMLIMIN} = 10$  mV.

Fig.8 Adjustment of soft mute start.

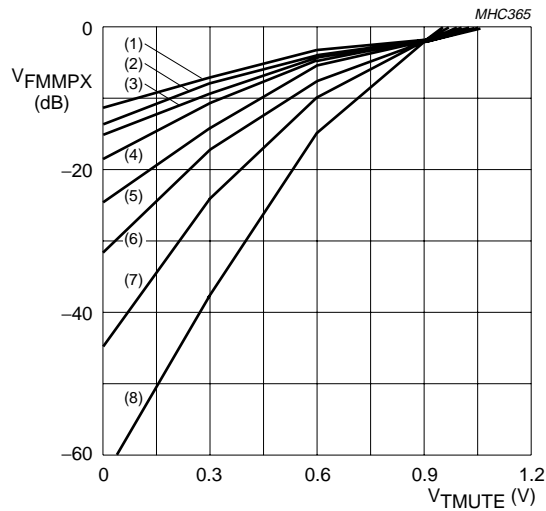

Mute slope:

- (1) MS[2:0] = 000.
- (2) MS[2:0] = 001.
- (3) MS[2:0] = 010.
- (4) MS[2:0] = 011.
- (5) MS[2:0] = 100.
- (6) MS[2:0] = 101.
- (7) MS[2:0] = 110.
- (8) MS[2:0] = 111.

Mute slope adjustment range, mute start = 100 and  $V_{FMLIMIN} = 10$  mV.

Fig.9 Adjustment of soft mute slope.

New In Car Entertainment (NICE)  
extended car radio

TEA6842H

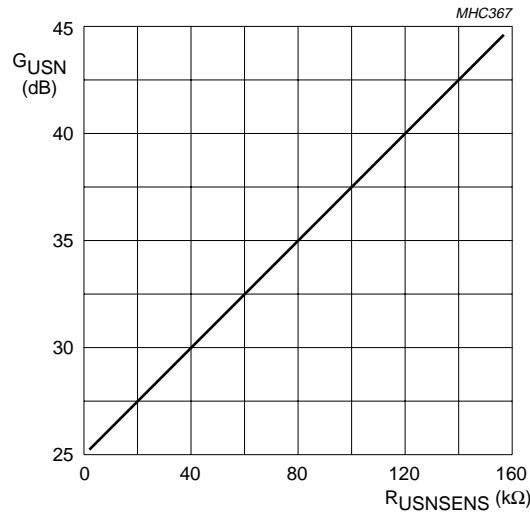

V\_TMUTE = 2.5 V; f\_mod = 750 kHz.

Fig.10 Ultrasonic noise detector gain as a function of R\_USNSENS.

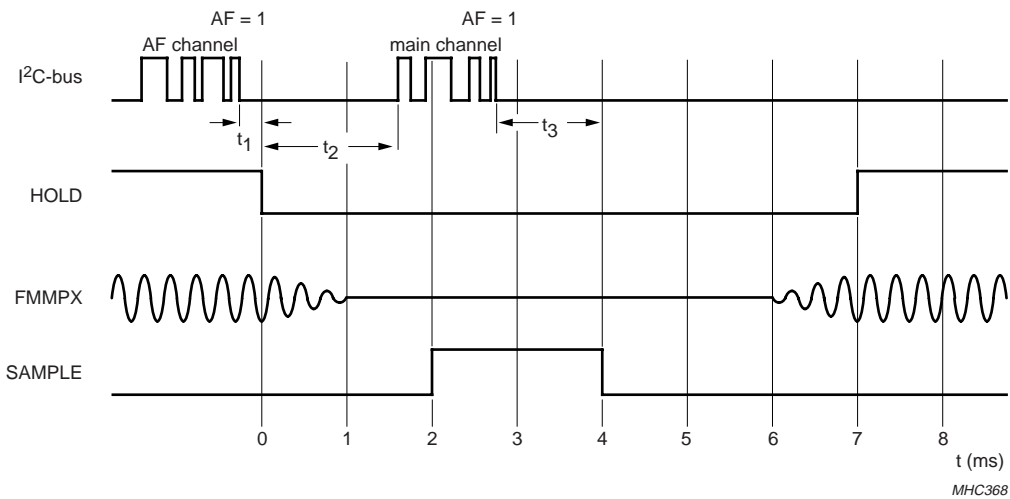

Hold signal is used to hold the quality information for signal processing of the main channel during the alternative frequency jumps.  
 Quality measurement can be carried out during sample = 1.  
 t<sub>1</sub> is the internal clock related logic delay of 100 μs.  
 t<sub>2</sub> should be >1.1 ms to ensure correct loading of PLL for the main channel.  
 t<sub>3</sub> should be >0 to ensure inaudible update; t<sub>3</sub> < 0 extends the mute period.

Fig.11 Inaudible RDS update timing diagram.

New In Car Entertainment (NICE)  
extended car radio

TEA6842H

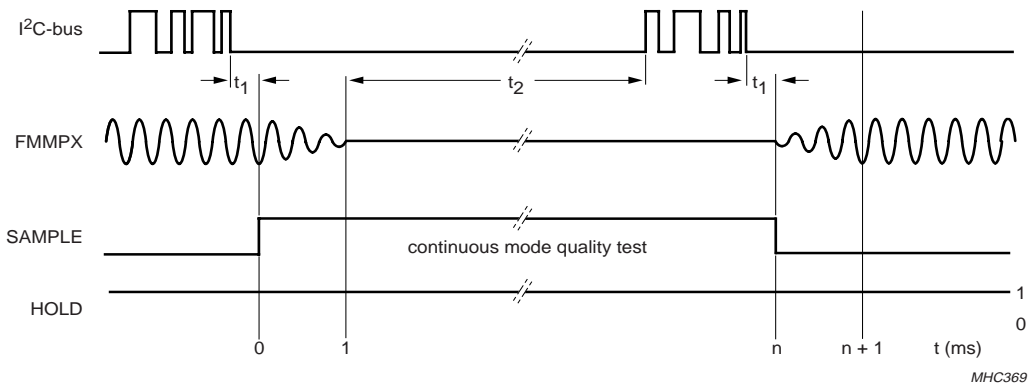

MHC369

t<sub>1</sub> is the internal clock related logic delay of 100 μs.

t<sub>2</sub> should be larger than the required PLL tuning time for the given band: FM = 1 ms and AM = 20 ms.

Fig.12 Preset mode timing diagram.

# New In Car Entertainment (NICE) extended car radio

TEA6842H

## 12 I<sup>2</sup>C-BUS PROTOCOL

### 12.1 I<sup>2</sup>C-bus specification

The standard I<sup>2</sup>C-bus specification is expanded by the following definitions.

IC addresses:

- 1st IC address C2H: 1100001 R/ $\overline{W}$
- 2nd IC address C0H: 1100000 R/ $\overline{W}$ .

A second I<sup>2</sup>C-bus address can be selected by connecting pin FREF via a 68 k $\Omega$  resistor to GND.

Structure of the I<sup>2</sup>C-bus logic: slave transceiver with auto increment.

Subaddresses are not used.

**Remark:** The I<sup>2</sup>C-bus operates at a maximum clock rate of 100 kHz. It is not allowed to connect the IC to an I<sup>2</sup>C-bus operating at a higher clock rate. Maximum LOW level is 1.5 V and minimum HIGH level is 3 V.

#### 12.1.1 DATA TRANSFER

Data sequence: address, byte 1, byte 2, byte 3, byte 4, byte 5, byte 6 and byte 7. The data transfer has to be in this order. The LSB = 0 indicates a WRITE operation to the TEA6842H.

Bit 7 of each byte is considered the MSB and has to be transferred as the first bit of the byte.

The data becomes valid at the output of the internal latches with the acknowledge of each byte. A STOP condition after any byte can shorten transmission times.

## 12.2 I<sup>2</sup>C-bus protocol

### 12.2.1 DATA TRANSFER MODE AND IC ADDRESS

**Table 1** Write mode

S <sup>(1)</sup>	address (write)	A <sup>(2)</sup>	data byte(s)	A <sup>(2)</sup>	P <sup>(3)</sup>
------------------	-----------------	------------------	--------------	------------------	------------------

#### Notes

1. S = START condition.
2. A = acknowledge.
3. P = STOP condition.

When writing to the transceiver by using the STOP condition before completion of the whole transfer:

- The remaining bytes will contain the old information
- If the transfer of a byte is not completed, this byte is lost and the previous information is available.

In byte 5, 4 bits are reserved for test mode purposes. The state of the test bits, if not in test mode, is don't care.

#### 12.1.2 I<sup>2</sup>C-BUS PULL-UP RESISTORS

When the IC is used together with the TEA688x or TEF689x and both SCL and SDA lines are connected via the I<sup>2</sup>C-bus to the TEA688x or TEF689x, the pull-up resistors of the tuner IC should be connected to the digital supply voltage of the TEA688x or TEF689x. Otherwise an I<sup>2</sup>C-bus pull-down can occur switching off the tuner IC supply when the I<sup>2</sup>C-bus buffer interface of the TEA688x or TEF689x is enabled for data transfer to the tuner IC.

#### 12.1.3 FREQUENCY SETTING

For new frequency setting, in both AM and FM mode, the programmable divider is enabled by setting bit MUTE = 1. To select an FM frequency, two I<sup>2</sup>C-bus transmissions are necessary:

- First: bit MUTE = 1
- Second: bit MUTE = 0.

#### 12.1.4 DEFAULT SETTINGS

**No default settings at power-on reset.** One I<sup>2</sup>C-bus transmission is required to program the IC.

## New In Car Entertainment (NICE) extended car radio

TEA6842H

**Table 2** Read mode

S <sup>(1)</sup>	address (read)	A <sup>(2)</sup>	data byte 1
------------------	----------------	------------------	-------------

**Notes**

1. S = START condition.
2. A = acknowledge.

**Table 3** IC address byte

IC ADDRESS						MODE
1	1	0	0	0	0	0/1 <sup>(1)</sup>
						R/ $\bar{W}$ <sup>(2)</sup>

**Notes**

1. Defined by address pin FREF:
  - a) 1 = 1st IC address
  - b) 0 = 2nd IC address.
2. Read or write mode:
  - a) 0 = write operation to TEA6842H
  - b) 1 = read operation from TEA6842H.

## 12.2.2 WRITE MODE: DATA BYTE 1

**Table 4** Format of data byte 1

BIT 7	BIT 6	BIT 5	BIT 4	BIT 3	BIT 2	BIT 1	BIT 0
AF	PLL14	PLL13	PLL12	PLL11	PLL10	PLL9	PLL8

**Table 5** Description of data byte 1 bits

BIT	SYMBOL	DESCRIPTION
7	AF	<b>Alternative frequency.</b> If AF = 0, then normal operation. If AF = 1, then AF (RDS) update mode.
6 to 0	PLL[14:8]	<b>Setting of programmable counter of synthesizer PLL.</b> Upper byte of PLL divider word.

## 12.2.3 WRITE MODE: DATA BYTE 2

**Table 6** Format of data byte 2

BIT 7	BIT 6	BIT 5	BIT 4	BIT 3	BIT 2	BIT 1	BIT 0
PLL7	PLL6	PLL5	PLL4	PLL3	PLL2	PLL1	PLL0

**Table 7** Description of data byte 2 bits

BIT	SYMBOL	DESCRIPTION
7 to 0	PLL[7:0]	<b>Setting of programmable counter of synthesizer PLL.</b> Lower byte of PLL divider word.

## New In Car Entertainment (NICE) extended car radio

TEA6842H

### 12.2.4 WRITE MODE: DATA BYTE 3

**Table 8** Format of data byte 3

BIT 7	BIT 6	BIT 5	BIT 4	BIT 3	BIT 2	BIT 1	BIT 0
MUTE	DAA6	DAA5	DAA4	DAA3	DAA2	DAA1	DAA0

**Table 9** Description of data byte 3 bits

BIT	SYMBOL	DESCRIPTION
7	MUTE	<b>FM audio mute.</b> If MUTE = 0, then FM audio not muted. If MUTE = 1, then FM audio muted; writing to programmable divider and antenna DAA enabled.
6 to 0	DAA[6:0]	<b>Setting of antenna digital auto alignment.</b>

### 12.2.5 WRITE MODE: DATA BYTE 4

**Table 10** Format of data byte 4

BIT 7	BIT 6	BIT 5	BIT 4	BIT 3	BIT 2	BIT 1	BIT 0
IFMT	RFS2	RFS1	RFS0	IFPR	BND1	BND0	AMFM

**Table 11** Description of data byte 4 bits

BIT	SYMBOL	DESCRIPTION
7	IFMT	<b>IF measuring time.</b> If IFMT = 0, then IF measuring time is 20 ms. If IFMT = 1, then IF measuring time is 2 ms.
6 to 4	RFS[2:0]	<b>Reference frequency for synthesizer.</b> These 3 bits determine the reference frequency, see Table 12.
3	IFPR	<b>IF counter prescaler ratio.</b> If IFPR = 0, then IF prescaler ratio is 100. If IFPR = 1, then IF prescaler ratio is 10.
2 and 1	BND[1:0]	<b>Band switch.</b> These 2 bits select in FM mode band and local or distant, see Table 13; in AM mode band select and output of AM IF2 for AM stereo, see Table 14.
0	AMFM	<b>AM or FM switch.</b> If AMFM = 0, then FM mode. If AMFM = 1, then AM mode.

**Table 12** Reference frequency setting

RFS2	RFS1	RFS0	f <sub>ref</sub> (kHz)
0	0	0	100
1	0	0	50
0	1	0	25
1	1	0	20
0	0	1	10
1	0	1	10
0	1	1	10
1	1	1	10

## New In Car Entertainment (NICE) extended car radio

TEA6842H

**Table 13** FM mode

BND1	BND0	SELECTION
0	0	FM standard: dead zone high current charge pump active, FM AGC defined by RF level and threshold level setting by I <sup>2</sup> C-bus
0	1	FM local: dead zone high current charge pump active, FM AGC source current set to maximum
1	0	FM East Europe: dead zone high current charge pump switched off, current of low current charge pump set to 1 mA
1	1	FM weather band: N1 divider set to 1 and I and Q phase shift network switched on, WX flag signal activated

**Table 14** AM mode; note 1

BND1	BND0	SELECTION
0	0	AM mono; N2 divider set to 5 (SW)
0	1	AM stereo; N2 divider set to 5 (SW)
1	0	AM mono; N2 divider set to 10 (LW, MW)
1	1	AM stereo; N2 divider set to 10 (LW, MW)

**Note**

- In AM mode dead zone high current charge pump switched off, current of low current charge pump set to 1 mA.

## 12.2.6 WRITE MODE: DATA BYTE 5

**Table 15** Format of data byte 5

BIT 7	BIT 6	BIT 5	BIT 4	BIT 3	BIT 2	BIT 1	BIT 0
KAGC	WBA1	WBA0	AMSM	TMS3	TMS2	TMS1	TMS0

**Table 16** Description of data byte 5 bits

BIT	SYMBOL	DESCRIPTION
7	KAGC	<b>Keyed FM AGC.</b> If KAGC = 0, then keyed FM AGC is off. If KAGC = 1, then keyed FM AGC is on.
6 and 5	WBA[1:0]	<b>Wideband AGC.</b> These 2 bits set the start value of wideband AGC. For AM, see Table 17 and for FM, see Table 18.
4	AMSM	<b>AM soft mute.</b> If AMSM = 0, then AM soft mute is off. If AMSM = 1, then AM soft mute is on (default).
3	TMS3	<b>In test mode charge pump 3-state.</b> If TMS3 = 0, then 3-state off. If TMS3 = 1, then 3-state on.
2	TMS2	<b>In test mode external clock for level and antenna DAA.</b> If TMS2 = 0, then external clock disabled. If TMS2 = 1, then external clock enabled.
1 and 0	TMS[1:0]	<b>In test mode setting of pin FREF.</b> These 2 bits define the function of pin FREF, see Table 19.



## New In Car Entertainment (NICE) extended car radio

TEA6842H

**Table 17** Setting of wideband AGC for AM

WBA1	WBA0	AM MIXER 1 INPUT VOLTAGE (PEAK VALUE) (mV)
0	0	375
0	1	500
1	0	625
1	1	750

**Table 18** Setting of wideband AGC for FM

WBA1	WBA0	FM RF MIXER INPUT VOLTAGE (RMS VALUE) (mV)
1	1	4
1	0	8
0	1	12
0	0	16

**Table 19** Setting function of pin FREF in test mode

TMS1	TMS0	OUTPUT AT PIN FREF
0	0	reference frequency of TEA688x or TEF689x
0	1	tuner oscillator frequency divided by division ratio of programmable divider
1	0	PLL synthesizer reference frequency
1	1	not used (no output)

## 12.2.7 WRITE MODE: DATA BYTE 6

**Table 20** Format of data byte 6

BIT 7	BIT 6	BIT 5	BIT 4	BIT 3	BIT 2	BIT 1	BIT 0
LST4	LST3	LST2	LST1	LST0	LSL2	LSL1	LSL0

**Table 21** Description of data byte 6 bits

BIT	SYMBOL	DESCRIPTION
7 to 3	LST[4:0]	<b>Setting of level DAA starting point.</b> These 5 bits determine the offset of the level detector output voltage.
2 to 0	LSL[2:0]	<b>Setting of level DAA slope.</b> These 3 bits determine the steepness of the level detector output voltage.

**Table 22** Standard setting of data byte 6 bits

SETTING OF LEVEL DAA STARTING POINT					SETTING OF LEVEL DAA SLOPE		
LST4	LST3	LST2	LST1	LST0	LSL2	LSL1	LSL0
1	0	0	0	0	1	0	0

## New In Car Entertainment (NICE) extended car radio

TEA6842H

### 12.2.8 WRITE MODE: DATA BYTE 7

**Table 23** Format of data byte 7

BIT 7	BIT 6	BIT 5	BIT 4	BIT 3	BIT 2	BIT 1	BIT 0
0	0	MS2	MS1	MS0	MD2	MD1	MD0

**Table 24** Description of data byte 7 bits

BIT	SYMBOL	DESCRIPTION
7 and 6	–	These bits are not used and must be set to logic 0.
5 to 3	MS[2:0]	<b>Setting of soft mute slope</b> ; see Fig.9.
2 to 0	MD[2:0]	<b>Setting of soft mute start</b> ; see Fig.8.

### 12.2.9 READ MODE: DATA BYTE 1

**Table 25** Format of 1st data byte

BIT 7	BIT 6	BIT 5	BIT 4	BIT 3	BIT 2	BIT 1	BIT 0
IFC7	IFC6	IFC5	IFC4	IFC3	IFC2	IFC1	IFC0

**Table 26** Description of data byte 1 bits

BIT	SYMBOL	DESCRIPTION
7 to 0	IFC[7:0]	<b>IF counter result.</b> These bits contain the last eight bits of the IF counter result.

## New In Car Entertainment (NICE) extended car radio

TEA6842H

### 13 TEST AND APPLICATION INFORMATION

**Table 27** List of components

SYMBOL	PARAMETER	TYPE	MANUFACTURER
C1	capacitor for VCO tuning	270 pF; type NP0	–
L1	10.7 MHz IF coil	P7 PSG P826RC 5134N=S	TOKO
L2	450 kHz IF coil	P7PSGAE-5078D=S	TOKO
L3	10.7 MHz demodulator coil	392BC-1977Z	TOKO
L4	oscillator coil	E543SNAS-02010	TOKO
L5	FM image rejection	611SNS-1066Y	TOKO
L6	FM input transformer	369INS-3076X	TOKO
L7	–	LQN	MURATA
L8	–	LQN	MURATA
L9	–	Air coil	–
–	crystal 20.5 MHz	TQX6238	Tele Quarz

New In Car Entertainment (NICE)  
extended car radio

TEA6842H

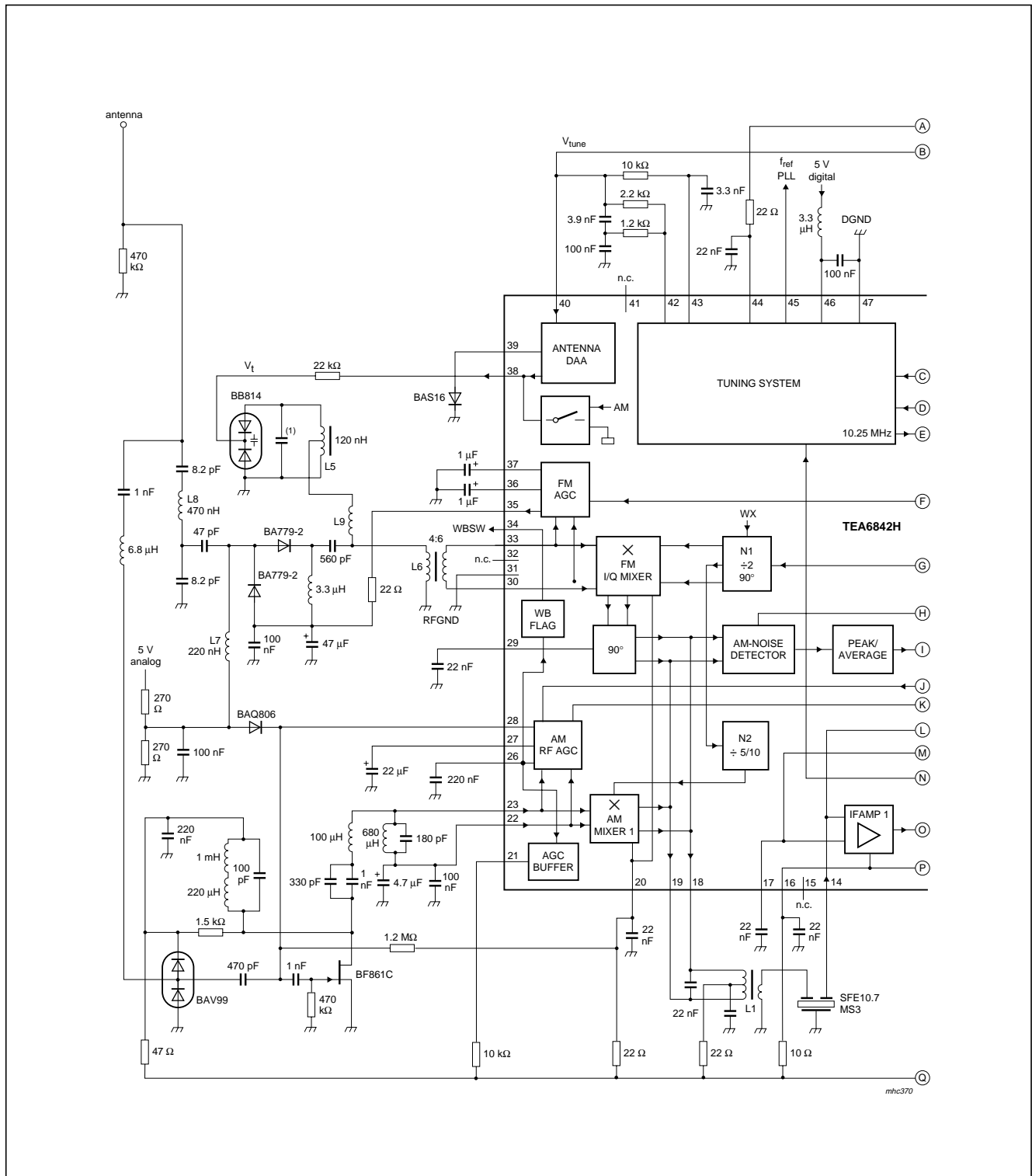

For list of components see Table 27.  
(1) 1 to 5 pF trimmer without DAA.

Fig.13 Application diagram (continued in Fig.14).

# New In Car Entertainment (NICE) extended car radio

## TEA6842H

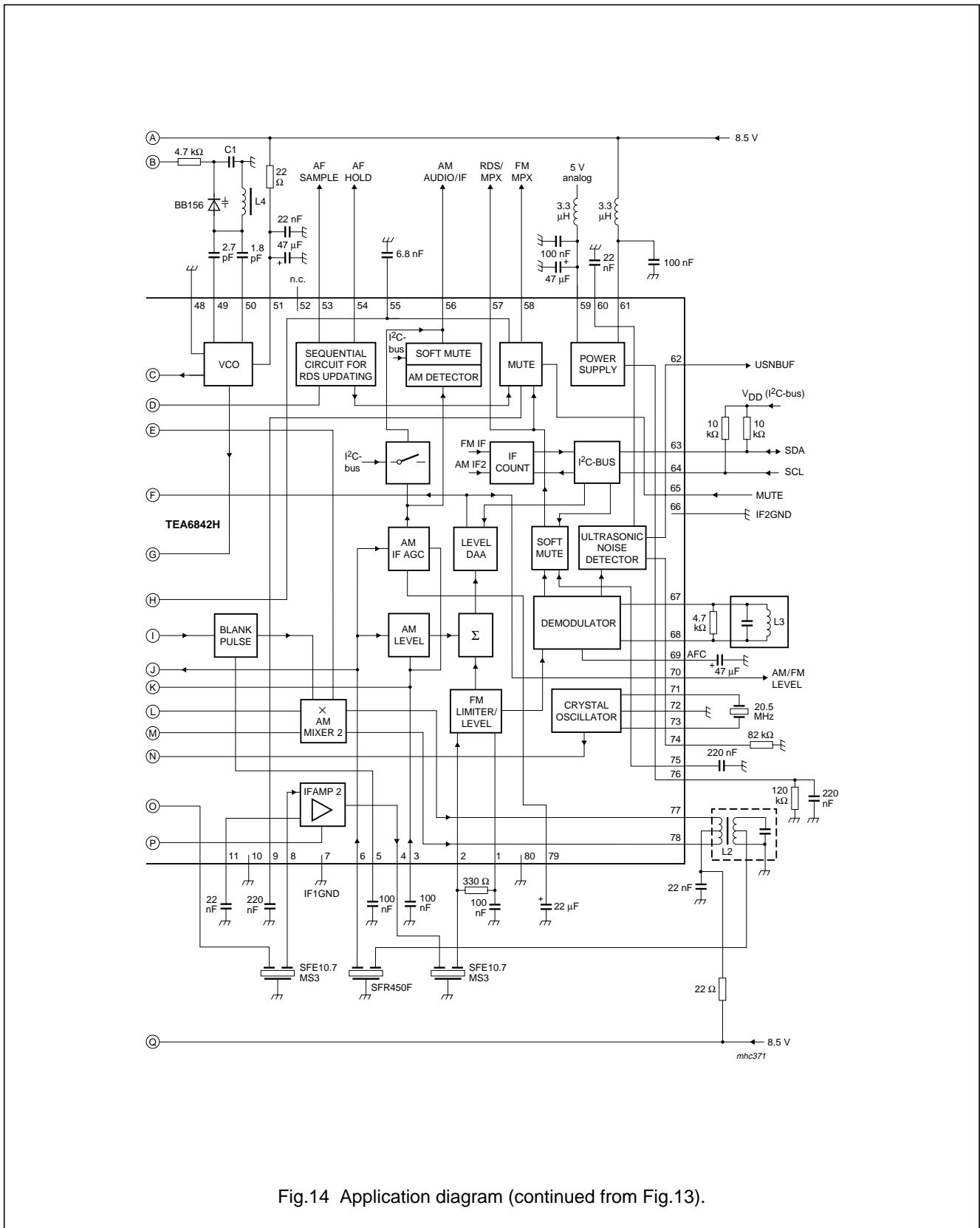
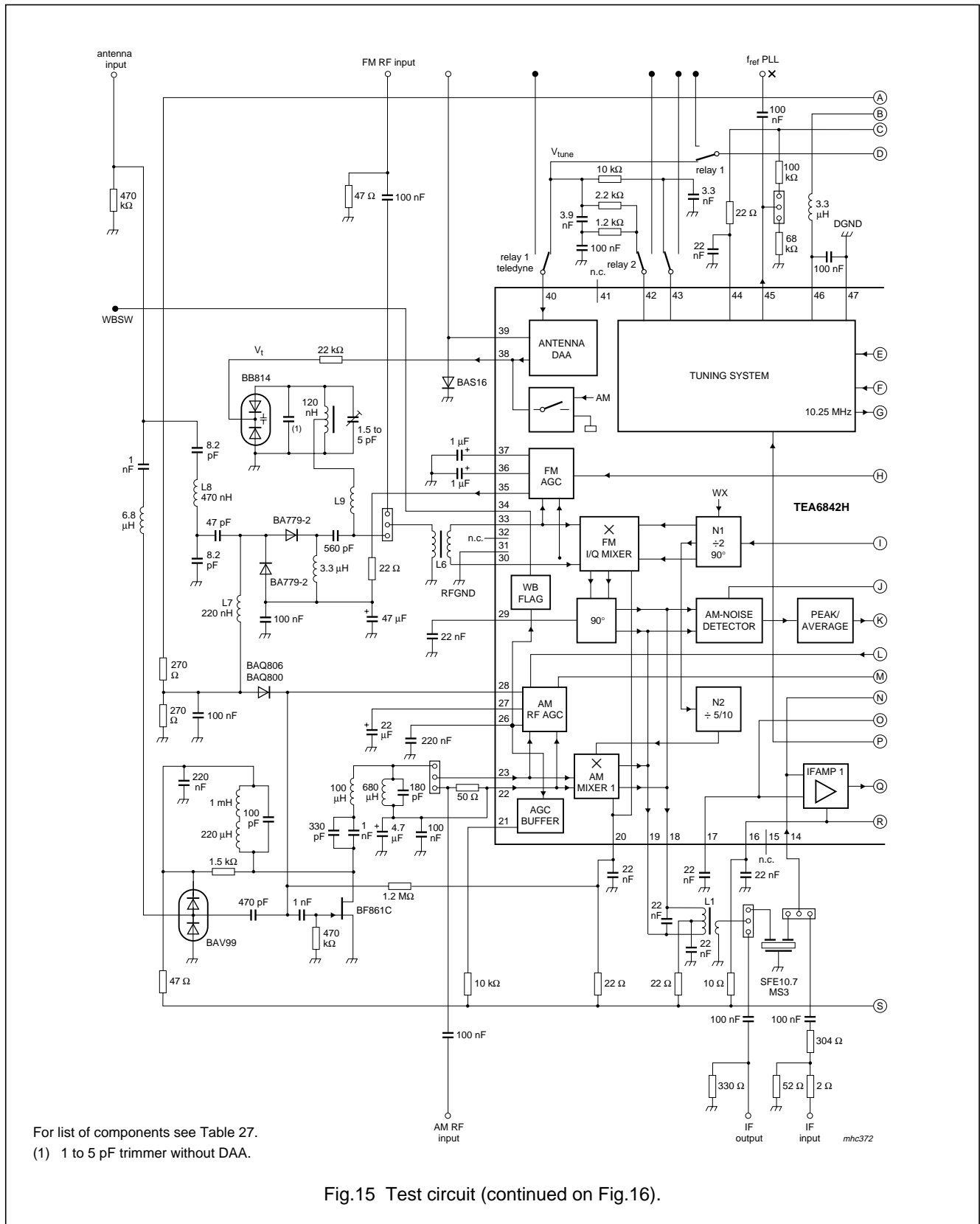

Fig.14 Application diagram (continued from Fig.13).

# New In Car Entertainment (NICE) extended car radio

## TEA6842H



# New In Car Entertainment (NICE) extended car radio

## TEA6842H

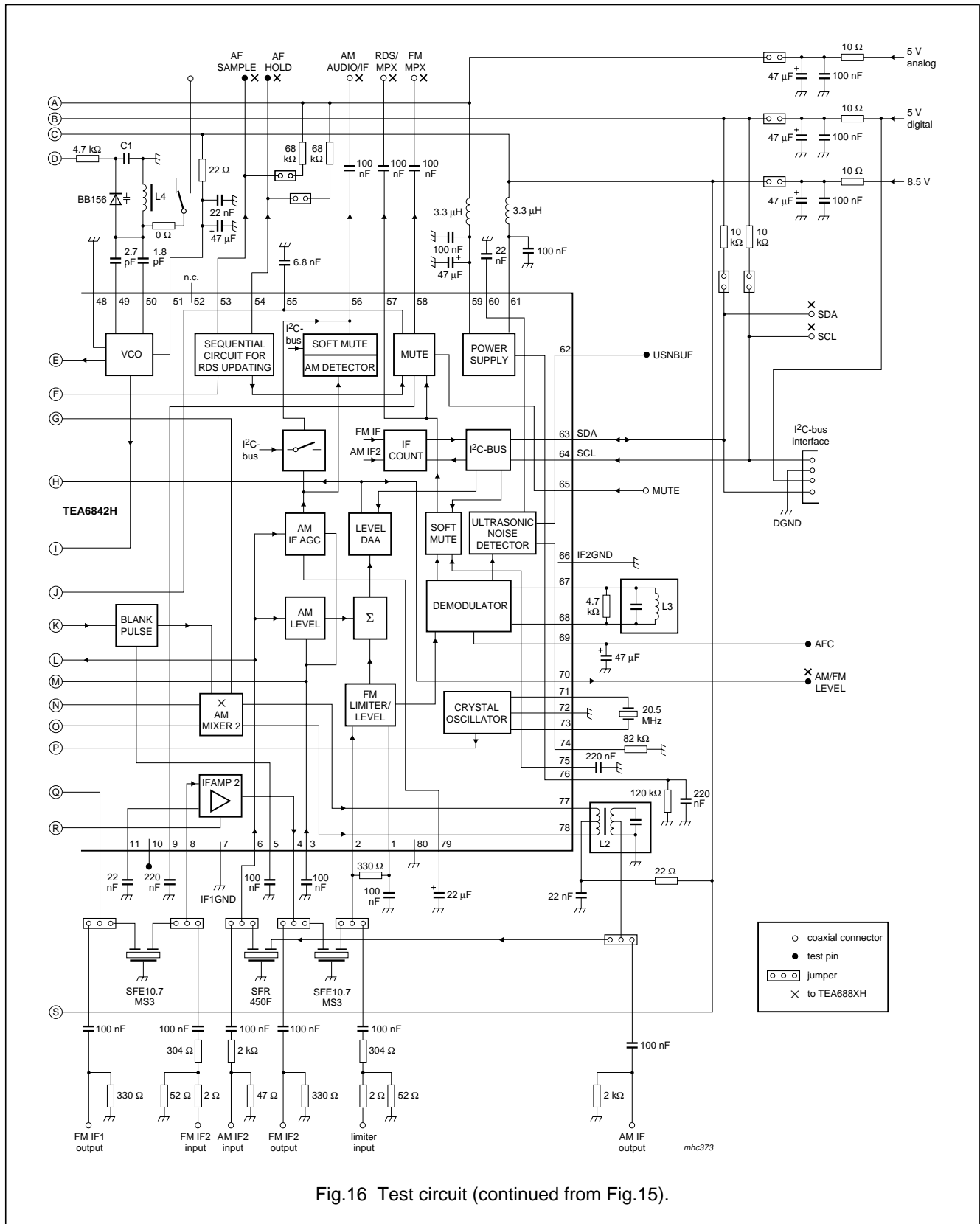

Fig.16 Test circuit (continued from Fig.15).

# New In Car Entertainment (NICE) extended car radio

TEA6842H

**Table 28** DC operating points

SYMBOL	PIN	UNLOADED DC VOLTAGE (V)					
		AM			FM		
		MIN.	TYP.	MAX.	MIN.	TYP.	MAX.
FMLIMDEC	1	2.5	3	3.5	2.5	2.8	3.1
FMLIMIN	2	2.5	3	3.5	2.5	2.8	3.1
AMIF2DEC	3	2.4	2.7	3.2	floating		
IFAMP2OUT	4	7.2	7.9	–	3.4	3.9	4.4
AMNBHOLD	5	4.4	4.75	5.25	8	8.4	–
AMIF2IN	6	2.4	2.7	3.2	floating		
IF1GND	7	external 0			external 0		
IFAMP2IN	8	3	3.4	3.8	2.7	3.1	3.5
C <sub>offset</sub>	9	floating			3	3.5	4
IMUTEREF	10	external biased (ground)			external biased (ground)		
IFAMP2DEC	11	3	3.4	3.8	2.7	3.1	3.5
IFAMP1OUT	12	7.2	7.9	–	3.6	4	4.4
IFAMP1IN	14	2.4	2.8	3.2	2.3	2.7	3.1
V <sub>DDA1</sub>	16	external 8.5			external 8.5		
IFAMP1DEC	17	2.4	2.8	3.2	2.3	2.7	3.1
MIX1OUT1	18	external 8.5			external 8.5		
MIX1OUT2	19	external 8.5			external 8.5		
V <sub>DDA2</sub>	20	external 8.5			external 8.5		
AMAGCBUF	21	external biased			floating		
AMMIX1IN2	22	2.4	2.85	3.2	floating		
AMMIX1IN1	23	external biased			floating		
T1AMAGC	26	0	2.8	4.6	0 (no WX)	0.3 (no WX)	0.5 (no WX)
T2AMAGC	27	2.5	2.8	3.1	floating		
IAMAGC	28	external biased			external biased		
V <sub>ref(FMMIX)</sub>	29	2.7	3.1	3.4	6.5	7.1	7.9
FMMIXIN1	30	1	1.3	1.6	2.3	2.8	3.3
RFGND	31	external 0			external 0		
FMMIXIN2	33	1	1.3	1.6	2.3	2.8	3.3
WBSW	34	floating			4 (WB)	4.5 (WB)	5 (WB)
					– (FM)	<0.5 (FM)	– (FM)
IFMAGC	35	external biased			1.5 (external biasing)	–	4 (external biasing)
T2FMAGC	36	7.5	8	8.3	3.6	4.2	4.6
T1FMAGC	37	floating			1	–	7
DAAOUT	38	–	0.2	0.3	0.2	–	8.25
DAATD	39	floating			0.2	–	1.5
DAAIN	40	0	–	8.5	0	–	8.5



# New In Car Entertainment (NICE) extended car radio

TEA6842H

SYMBOL	PIN	UNLOADED DC VOLTAGE (V)					
		AM			FM		
		MIN.	TYP.	MAX.	MIN.	TYP.	MAX.
V <sub>tune</sub>	42	0	–	8.5	0	–	8.5
CPOUT	43	0	–	8.5	0	–	8.5
V <sub>DDA3</sub>	44	external 8.5			external 8.5		
FREF	45	3.2	3.4	3.7	3.2	3.4	3.7
V <sub>DDD</sub>	46	external 5			external 5		
DGND	47	external 0			external 0		
VCOGND	48	external 0			external 0		
OSCFDB	49	2.2	2.8	3.4	2.2	2.8	3.4
OSCTNK	50	5	6	7	5	6	7
V <sub>DDA4</sub>	51	external 8.5			external 8.5		
AFSAMPLE	53	0	0.2	0.5	0	0.2	0.5
AFHOLD	54	open-collector			open-collector		
TRDSMUTE	55	1.9	2.2	2.5	0.7 (muted)	1.2 (muted)	1.7 (muted)
					5.2 (not muted)	5.7 (not muted)	6.2 (not muted)
AMAFIF2	56	4	4.3	4.6	floating		
RDSMPX	57	floating			2.6	3.1	3.3
FMMPX	58	floating			3	3.5	4
V <sub>DDA5</sub>	59	external 5			external 5		
TUSN	60	floating			0.5	–	5
V <sub>DDA6</sub>	61	external 8.5			external 8.5		
USNBUF	62	floating			0.5	–	5
SDA	63	4.8	5	5.2	4.8	5	5.2
SCL	64	4.8	5	5.2	4.8	5	5.2
MUTE	65	floating			external biased		
IF2GND	66	external 0			external 0		
QDET1	67	floating			3.6	4.1	4.6
QDET2	68	floating			3.6	4.1	4.6
C <sub>AFC</sub>	69	floating			1.2	3.4	4.1
V <sub>level</sub>	70	0	–	7	0	–	7
XTAL1	71	1.7	2.1	2.5	1.7	2.1	2.5
XTALGND	72	external 0			external 0		
XTAL2	73	1.7	2.1	2.5	1.7	2.1	2.5
USNSENS	74	floating			external biased		
TMUTE	75	0	–	5	0	–	5
IREF	76	4	4.25	4.5	4	4.25	4.5
AMMIX2OUT1	77	external 8.5			external 8.5		
AMMIX2OUT2	78	external 8.5			external 8.5		
C <sub>AGC</sub>	79	4.1	4.4	4.7	4	4.5	5

New In Car Entertainment (NICE)  
extended car radio

TEA6842H

14 INTERNAL CIRCUITRY

Table 29 Equivalent pin circuits

PIN	SYMBOL	EQUIVALENT CIRCUIT
1 2	FMLIMDEC FMLIMIN	
3 6	AMIF2DEC AMIF2IN	
4	IFAMP2OUT	
5	AMNBHOLD	
7	IF1GND	

New In Car Entertainment (NICE)  
extended car radio

TEA6842H

PIN	SYMBOL	EQUIVALENT CIRCUIT
8	IFAMP2IN	
11	IFAMP2DEC	
9	C <sub>offset</sub>	
10	IMUTEREF	
12	IFAMP1OUT	
13	n.c.	
14	IFAMP1IN	
17	IFAMP1DEC	
15	n.c.	

New In Car Entertainment (NICE)  
extended car radio

TEA6842H

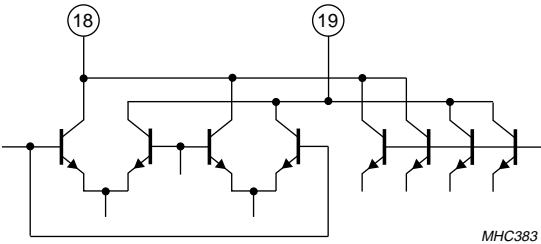
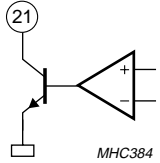
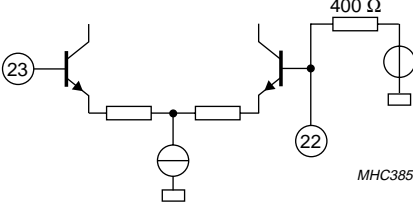
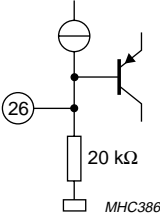
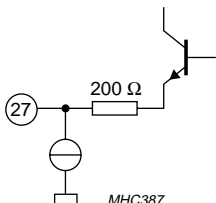
PIN	SYMBOL	EQUIVALENT CIRCUIT
16	$V_{DDA1}$	
18	MIX1OUT1	
19	MIX1OUT2	
20	$V_{DDA2}$	
21	AMAGCBUF	
22	AMMIX1IN2	
23	AMMIX1IN1	
24	n.c.	
25	n.c.	
26	T1AMAGC	
27	T2AMAGC	

New In Car Entertainment (NICE)  
extended car radio

TEA6842H

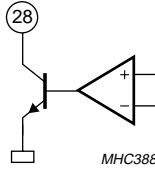
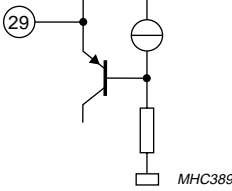
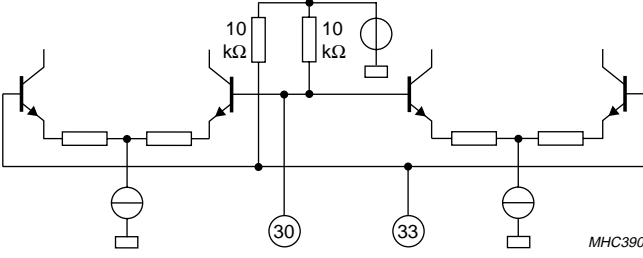
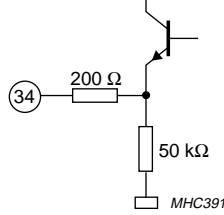
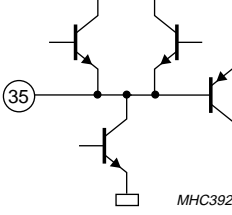
PIN	SYMBOL	EQUIVALENT CIRCUIT
28	IAMAGC	
29	$V_{ref(FMMIX)}$	
30	FMMIXIN1	
33	FMMIXIN2	
31	RFGND	
32	n.c.	
34	WBSW	
35	IFMAGC	

New In Car Entertainment (NICE)  
extended car radio

TEA6842H

PIN	SYMBOL	EQUIVALENT CIRCUIT
36	T2FMAGC	
37	T1FMAGC	
38	DAAOUT	
39	DAATD	

New In Car Entertainment (NICE)  
extended car radio

TEA6842H

PIN	SYMBOL	EQUIVALENT CIRCUIT
40	DAAIN	
41	n.c.	
42	$V_{tune}$	
43	CPOUT	
44	$V_{DDA3}$	
45	FREF	
46	$V_{DDD}$	
47	DGND	

New In Car Entertainment (NICE)  
extended car radio

TEA6842H

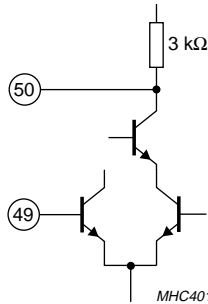
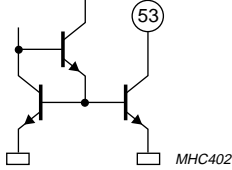
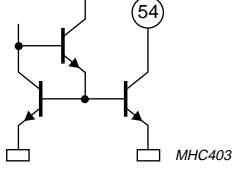
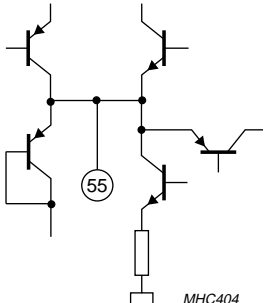
PIN	SYMBOL	EQUIVALENT CIRCUIT
48	VCOGND	
49	OSCFDB	
50	OSCTNK	
51	V <sub>DDA4</sub>	
52	n.c.	
53	AFSAMPLE	
54	AFHOLD	
55	TRDSMUTE	



New In Car Entertainment (NICE)  
extended car radio

TEA6842H

PIN	SYMBOL	EQUIVALENT CIRCUIT
56	AMAFIF2	
57	RDSMPX	
58	FMMPX	
59	V <sub>DDA5</sub>	
60	TUSN	
61	V <sub>DDA6</sub>	

New In Car Entertainment (NICE)  
extended car radio

TEA6842H

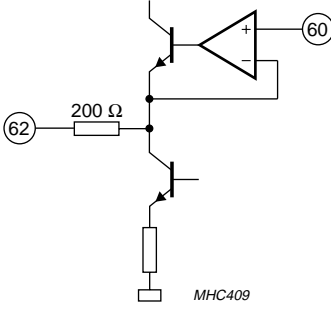
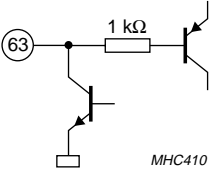
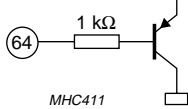
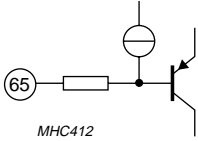
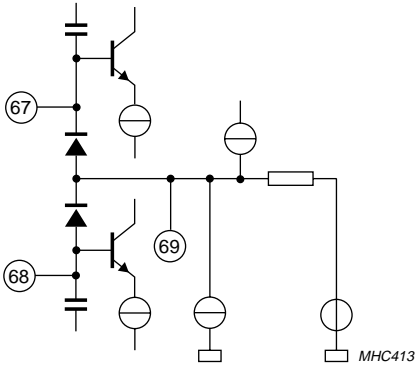
PIN	SYMBOL	EQUIVALENT CIRCUIT
62	USNBUF	 <p>MHC409</p>
63	SDA	 <p>MHC410</p>
64	SCL	 <p>MHC411</p>
65	MUTE	 <p>MHC412</p>
66	IF2GND	
67	QDET1	
68	QDET2	
69	C <sub>AFC</sub>	 <p>MHC413</p>

New In Car Entertainment (NICE)  
extended car radio

TEA6842H

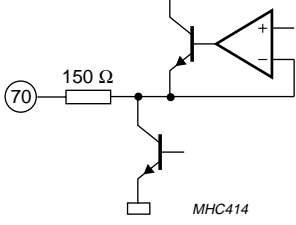
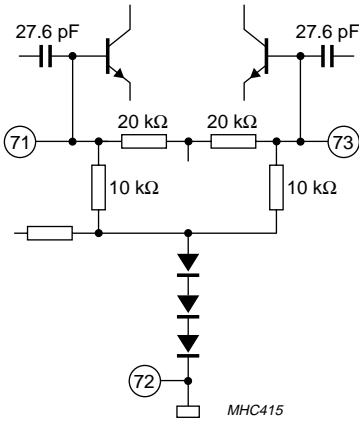
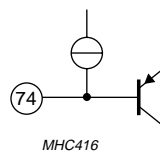
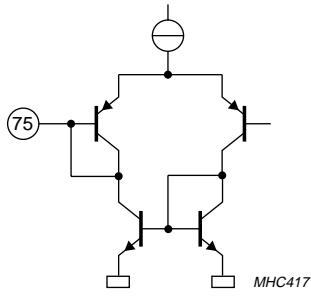
PIN	SYMBOL	EQUIVALENT CIRCUIT
70	$V_{level}$	
71	XTAL1	
72	XTALGND	
73	XTAL2	
74	USNSENS	
75	TMUTE	

New In Car Entertainment (NICE)  
extended car radio

TEA6842H

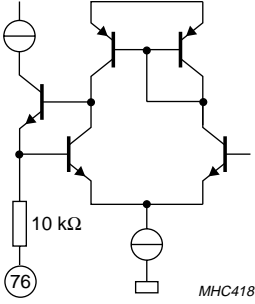
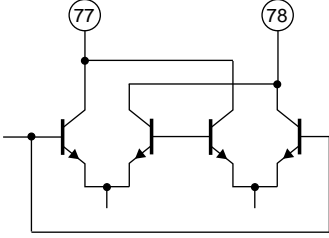
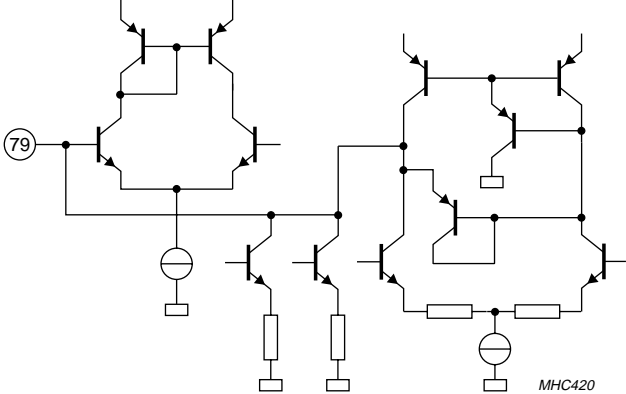
PIN	SYMBOL	EQUIVALENT CIRCUIT
76	IREF	
77	AMMIX2OUT1	
78	AMMIX2OUT2	
79	C <sub>AGC</sub>	
80	n.c.	

New In Car Entertainment (NICE)  
extended car radio

TEA6842H

15 PACKAGE OUTLINE

LQFP80: plastic low profile quad flat package; 80 leads; body 12 x 12 x 1.4 mm

SOT315-1

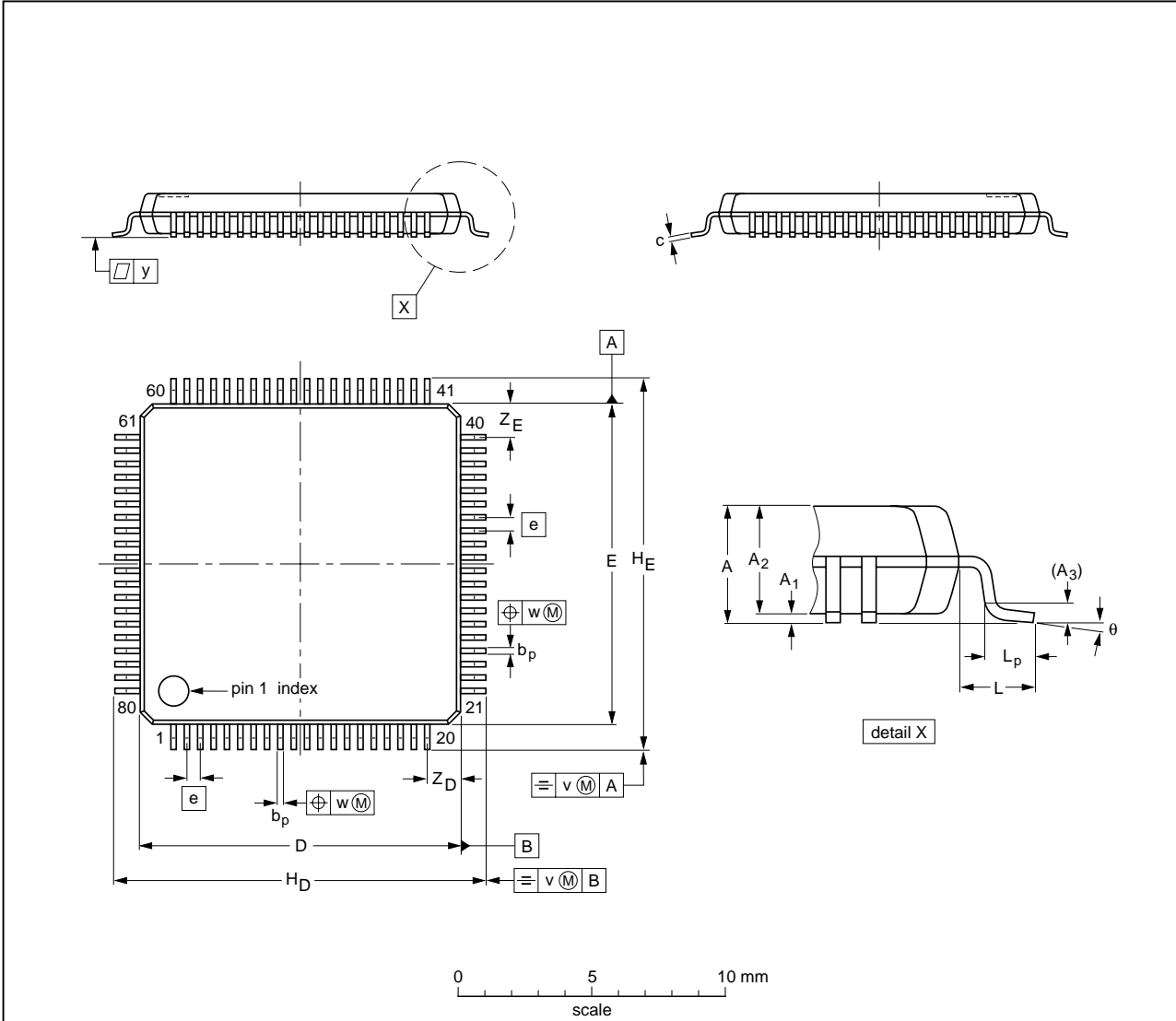

DIMENSIONS (mm are the original dimensions)

UNIT	A max.	A <sub>1</sub>	A <sub>2</sub>	A <sub>3</sub>	b <sub>p</sub>	c	D <sup>(1)</sup>	E <sup>(1)</sup>	e	H <sub>D</sub>	H <sub>E</sub>	L	L <sub>p</sub>	v	w	y	Z <sub>D</sub> <sup>(1)</sup>	Z <sub>E</sub> <sup>(1)</sup>	θ
mm	1.6	0.16 0.04	1.5 1.3	0.25	0.27 0.13	0.18 0.12	12.1 11.9	12.1 11.9	0.5	14.15 13.85	14.15 13.85	1	0.75 0.30	0.2	0.15	0.1	1.45 1.05	1.45 1.05	7° 0°

Note

1. Plastic or metal protrusions of 0.25 mm maximum per side are not included.

OUTLINE VERSION	REFERENCES			EUROPEAN PROJECTION	ISSUE DATE
	IEC	JEDEC	JEITA		
SOT315-1	136E15	MS-026			00-01-19 03-02-25

## New In Car Entertainment (NICE) extended car radio

TEA6842H

### 16 SOLDERING

#### 16.1 Introduction to soldering surface mount packages

This text gives a very brief insight to a complex technology. A more in-depth account of soldering ICs can be found in our *"Data Handbook IC26; Integrated Circuit Packages"* (document order number 9398 652 90011).

There is no soldering method that is ideal for all surface mount IC packages. Wave soldering can still be used for certain surface mount ICs, but it is not suitable for fine pitch SMDs. In these situations reflow soldering is recommended.

#### 16.2 Reflow soldering

Reflow soldering requires solder paste (a suspension of fine solder particles, flux and binding agent) to be applied to the printed-circuit board by screen printing, stencilling or pressure-syringe dispensing before package placement. Driven by legislation and environmental forces the worldwide use of lead-free solder pastes is increasing.

Several methods exist for reflowing; for example, convection or convection/infrared heating in a conveyor type oven. Throughput times (preheating, soldering and cooling) vary between 100 and 200 seconds depending on heating method.

Typical reflow peak temperatures range from 215 to 270 °C depending on solder paste material. The top-surface temperature of the packages should preferably be kept:

- below 225 °C (SnPb process) or below 245 °C (Pb-free process)
  - for all BGA, HTSSON-T and SSOP-T packages
  - for packages with a thickness  $\geq 2.5$  mm
  - for packages with a thickness  $< 2.5$  mm and a volume  $\geq 350$  mm<sup>3</sup> so called thick/large packages.
- below 240 °C (SnPb process) or below 260 °C (Pb-free process) for packages with a thickness  $< 2.5$  mm and a volume  $< 350$  mm<sup>3</sup> so called small/thin packages.

Moisture sensitivity precautions, as indicated on packing, must be respected at all times.

#### 16.3 Wave soldering

Conventional single wave soldering is not recommended for surface mount devices (SMDs) or printed-circuit boards with a high component density, as solder bridging and non-wetting can present major problems.

To overcome these problems the double-wave soldering method was specifically developed.

If wave soldering is used the following conditions must be observed for optimal results:

- Use a double-wave soldering method comprising a turbulent wave with high upward pressure followed by a smooth laminar wave.
- For packages with leads on two sides and a pitch (e):
  - larger than or equal to 1.27 mm, the footprint longitudinal axis is **preferred** to be parallel to the transport direction of the printed-circuit board;
  - smaller than 1.27 mm, the footprint longitudinal axis **must** be parallel to the transport direction of the printed-circuit board.

The footprint must incorporate solder thieves at the downstream end.

- For packages with leads on four sides, the footprint must be placed at a 45° angle to the transport direction of the printed-circuit board. The footprint must incorporate solder thieves downstream and at the side corners.

During placement and before soldering, the package must be fixed with a droplet of adhesive. The adhesive can be applied by screen printing, pin transfer or syringe dispensing. The package can be soldered after the adhesive is cured.

Typical dwell time of the leads in the wave ranges from 3 to 4 seconds at 250 °C or 265 °C, depending on solder material applied, SnPb or Pb-free respectively.

A mildly-activated flux will eliminate the need for removal of corrosive residues in most applications.

#### 16.4 Manual soldering

Fix the component by first soldering two diagonally-opposite end leads. Use a low voltage (24 V or less) soldering iron applied to the flat part of the lead. Contact time must be limited to 10 seconds at up to 300 °C.

When using a dedicated tool, all other leads can be soldered in one operation within 2 to 5 seconds between 270 and 320 °C.

## New In Car Entertainment (NICE) extended car radio

TEA6842H

### 16.5 Suitability of surface mount IC packages for wave and reflow soldering methods

PACKAGE <sup>(1)</sup>	SOLDERING METHOD	
	WAVE	REFLOW <sup>(2)</sup>
BGA, HTSSON..T <sup>(3)</sup> , LBGA, LFBGA, SQFP, SSOP..T <sup>(3)</sup> , TFBGA, USON, VFBGA	not suitable	suitable
DHVQFN, HBCC, HBGA, HLQFP, HSO, HSOP, HSQFP, HSSON, HTQFP, HTSSOP, HVQFN, HVSON, SMS	not suitable <sup>(4)</sup>	suitable
PLCC <sup>(5)</sup> , SO, SOJ	suitable	suitable
LQFP, QFP, TQFP	not recommended <sup>(5)(6)</sup>	suitable
SSOP, TSSOP, VSO, VSSOP	not recommended <sup>(7)</sup>	suitable
CWQCCN..L <sup>(8)</sup> , PMFP <sup>(9)</sup> , WQCCN..L <sup>(8)</sup>	not suitable	not suitable

#### Notes

- For more detailed information on the BGA packages refer to the “(LF)BGA Application Note” (AN01026); order a copy from your Philips Semiconductors sales office.
- All surface mount (SMD) packages are moisture sensitive. Depending upon the moisture content, the maximum temperature (with respect to time) and body size of the package, there is a risk that internal or external package cracks may occur due to vaporization of the moisture in them (the so called popcorn effect). For details, refer to the Drypack information in the “Data Handbook IC26; Integrated Circuit Packages; Section: Packing Methods”.
- These transparent plastic packages are extremely sensitive to reflow soldering conditions and must on no account be processed through more than one soldering cycle or subjected to infrared reflow soldering with peak temperature exceeding  $217\text{ °C} \pm 10\text{ °C}$  measured in the atmosphere of the reflow oven. The package body peak temperature must be kept as low as possible.
- These packages are not suitable for wave soldering. On versions with the heatsink on the bottom side, the solder cannot penetrate between the printed-circuit board and the heatsink. On versions with the heatsink on the top side, the solder might be deposited on the heatsink surface.
- If wave soldering is considered, then the package must be placed at a  $45^\circ$  angle to the solder wave direction. The package footprint must incorporate solder thieves downstream and at the side corners.
- Wave soldering is suitable for LQFP, TQFP and QFP packages with a pitch (e) larger than 0.8 mm; it is definitely not suitable for packages with a pitch (e) equal to or smaller than 0.65 mm.
- Wave soldering is suitable for SSOP, TSSOP, VSO and VSSOP packages with a pitch (e) equal to or larger than 0.65 mm; it is definitely not suitable for packages with a pitch (e) equal to or smaller than 0.5 mm.
- Image sensor packages in principle should not be soldered. They are mounted in sockets or delivered pre-mounted on flex foil. However, the image sensor package can be mounted by the client on a flex foil by using a hot bar soldering process. The appropriate soldering profile can be provided on request.
- Hot bar or manual soldering is suitable for PMFP packages.

## New In Car Entertainment (NICE) extended car radio

TEA6842H

### 17 DATA SHEET STATUS

LEVEL	DATA SHEET STATUS <sup>(1)</sup>	PRODUCT STATUS <sup>(2)(3)</sup>	DEFINITION
I	Objective data	Development	This data sheet contains data from the objective specification for product development. Philips Semiconductors reserves the right to change the specification in any manner without notice.
II	Preliminary data	Qualification	This data sheet contains data from the preliminary specification. Supplementary data will be published at a later date. Philips Semiconductors reserves the right to change the specification without notice, in order to improve the design and supply the best possible product.
III	Product data	Production	This data sheet contains data from the product specification. Philips Semiconductors reserves the right to make changes at any time in order to improve the design, manufacturing and supply. Relevant changes will be communicated via a Customer Product/Process Change Notification (CPCN).

#### Notes

1. Please consult the most recently issued data sheet before initiating or completing a design.
2. The product status of the device(s) described in this data sheet may have changed since this data sheet was published. The latest information is available on the Internet at URL <http://www.semiconductors.philips.com>.
3. For data sheets describing multiple type numbers, the highest-level product status determines the data sheet status.

### 18 DEFINITIONS

**Short-form specification** — The data in a short-form specification is extracted from a full data sheet with the same type number and title. For detailed information see the relevant data sheet or data handbook.

**Limiting values definition** — Limiting values given are in accordance with the Absolute Maximum Rating System (IEC 60134). Stress above one or more of the limiting values may cause permanent damage to the device. These are stress ratings only and operation of the device at these or at any other conditions above those given in the Characteristics sections of the specification is not implied. Exposure to limiting values for extended periods may affect device reliability.

**Application information** — Applications that are described herein for any of these products are for illustrative purposes only. Philips Semiconductors make no representation or warranty that such applications will be suitable for the specified use without further testing or modification.

### 19 DISCLAIMERS

**Life support applications** — These products are not designed for use in life support appliances, devices, or systems where malfunction of these products can reasonably be expected to result in personal injury. Philips Semiconductors customers using or selling these products for use in such applications do so at their own risk and agree to fully indemnify Philips Semiconductors for any damages resulting from such application.

**Right to make changes** — Philips Semiconductors reserves the right to make changes in the products - including circuits, standard cells, and/or software - described or contained herein in order to improve design and/or performance. When the product is in full production (status 'Production'), relevant changes will be communicated via a Customer Product/Process Change Notification (CPCN). Philips Semiconductors assumes no responsibility or liability for the use of any of these products, conveys no licence or title under any patent, copyright, or mask work right to these products, and makes no representations or warranties that these products are free from patent, copyright, or mask work right infringement, unless otherwise specified.



---

**New In Car Entertainment (NICE)  
extended car radio**

---

**TEA6842H****20 PURCHASE OF PHILIPS I<sup>2</sup>C COMPONENTS**

Purchase of Philips I<sup>2</sup>C components conveys a license under the Philips' I<sup>2</sup>C patent to use the components in the I<sup>2</sup>C system provided the system conforms to the I<sup>2</sup>C specification defined by Philips. This specification can be ordered using the code 9398 393 40011.

# ***Philips Semiconductors – a worldwide company***

## **Contact information**

For additional information please visit <http://www.semiconductors.philips.com>. Fax: +31 40 27 24825

For sales offices addresses send e-mail to: [sales.addresses@www.semiconductors.philips.com](mailto:sales.addresses@www.semiconductors.philips.com).

© Koninklijke Philips Electronics N.V. 2003

SCA75

All rights are reserved. Reproduction in whole or in part is prohibited without the prior written consent of the copyright owner.

The information presented in this document does not form part of any quotation or contract, is believed to be accurate and reliable and may be changed without notice. No liability will be accepted by the publisher for any consequence of its use. Publication thereof does not convey nor imply any license under patent- or other industrial or intellectual property rights.

Printed in The Netherlands

R32/01/pp66

Date of release: 2003 Dec 19

Document order number: 9397 750 10557

*Let's make things better.*

**Philips  
Semiconductors**



**PHILIPS**