

# HONGFA RELAY



## SUBMINIATURE POWER RELAY

Single-Pole, PC Board

# JQC-3FG



- UL & CUR file No.: E160454
- TÜV file No.: R9452527
- 15A,10A switching capabilities
- SPST-NO and SPDT configurations
- Subminiature, standard PCB layout, low cost

### CONTACT DATA

Arrangement	SPST-NO,	SPDT
Initial Contact Resistance Max. (at 1A 6VDC)	100mΩ	
Contact Material	AgSnO type	Silver alloy type
Contact Rating (Res. Load)	10A 250VAC	7A 250VAC
Max. switching voltage	250VAC/24VDC	
Max. switching current	15A	
Max. switching power	2500VA	1750VA
UL/CUR rating	15A 120VAC/24VDC 10A 250VAC	10A 120VAC/24VDC 7A 250VAC
TÜV rating	Silver alloy type:10A 120VAC/24VDC 7A 250VAC	
Expected Life min. operations	Mechanical	1X10 <sup>7</sup>
	Electrical	1X10 <sup>5</sup>
<b>COIL</b>		
Nominal coil power	0.36W (48V:0.51W)	

### SPECIFICATION

Initial Insulation Resistance	100MΩ, 500VDC	
Dielectric Strength	1500VAC,1minute	
Between coil and Contacts	750VAC,1minute	
Between open contacts	5,000VAC	
Surge Voltage between Contacts and coil	10ms	
Operate time (at nomi. Vot.)	5ms	
Release time (at nomi. Vot.)	-40 to +70℃	
Ambient temperature	35 to 85%	
Humidity	Shock	Functional
	Resistance	Destructive
		100m/s <sup>2</sup>
		1000m/s <sup>2</sup>
Vibration Resistance	1.5mm, 10 to 55Hz	
Termination	PCB	
Unit weight	Approx. 10g	
Construction	Sealed and Unsealed	

### TABLE

Nominal Voltage VDC	Pick-up Voltage VDC	Drop-out Voltage VDC	Max. Allowable Voltage VDC (at 20 °C)	Coil Resistance ±10% Ω
5	3.75	0.5	6.5	70
6	4.50	0.6	7.8	100
9	6.75	0.9	11.7	225
12	9.00	1.2	15.6	400
18	13.5	1.8	23.4	900
24	18.0	2.4	31.2	1600
48	36.0	4.8	62.4	4500

■ ORDERING INFORMATION

JQC-3FG — 012 — H S T

Coil voltage	Contact arrangement	Classification of type	Contact Material
5,6,9,12,18, 24,48VDC	H: SPST-NO Z: SPDT	S: Sealed Nil: Unsealed	T: AgSnO Nil: Silver alloy

■ OUTLINE DIMENSIONS , WIRING DIAGRAM AND PC BOARD LAYOUT

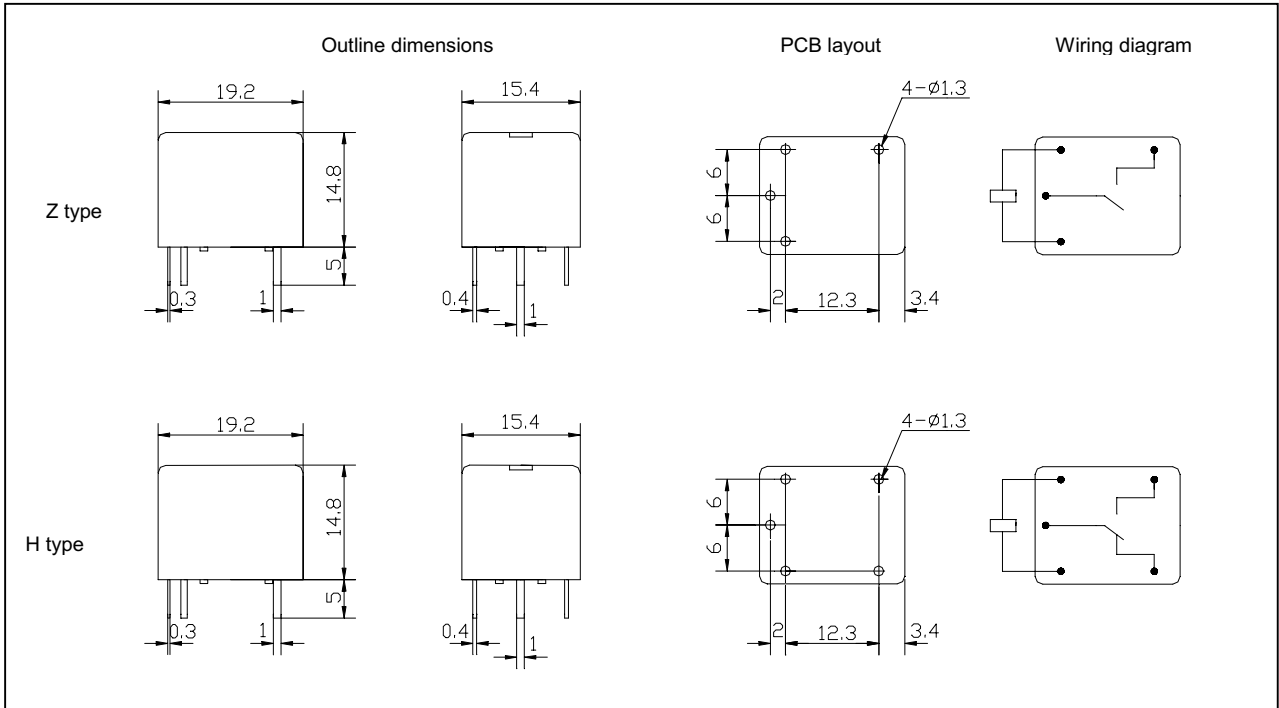

■ USEFUL CURVES

