

Thick Film, Rectangular, Trimmable, Resistor Chips

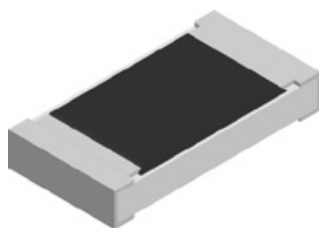

FEATURES

- Thick film on high quality ceramic
- Solder contacts on Ni barrier layer
- Can be trimmed to required value after insertion
- For applications in precision circuitry where relative tolerances can be compensated by trimming

STANDARD ELECTRICAL SPECIFICATIONS

MODEL	SIZE		POWER RATING P _{70°C} W	LIMITING ELEMENT VOLTAGE MAX V _≡	TEMPERATURE COEFFICIENT ppm/K	TOLERANCE %	RESISTANCE RANGE Ω	E-SERIES
	INCH	METRIC	CECC 40401-802/EIA-575					
D10TR --- CRCW0402TR	0402	1005	0.063	50	± 100	± 10; ± 15; ± 20 + 0 / - 30	10R - 10M	24
					± 200	± 10; ± 15; ± 20 + 0 / - 30	R47 - 10M	24
D11TR --- CRCW0603TR	0603	1608	0.1	75	± 100	± 10; ± 15; ± 20 + 0 / - 30	10R - 10M	24
					± 200	± 10; ± 15; ± 20 + 0 / - 30	R47 - 10M	24
D12TR --- CRCW0805TR	0805	2012	0.125	150	± 100	± 10; ± 15; ± 20 + 0 / - 30	10R - 10M	24
					± 200	± 10; ± 15; ± 20 + 0 / - 30	R47 - 10M	24
D25TR --- CRCW1206TR	1206	3216	0.25	200	± 100	± 10; ± 15; ± 20 + 0 / - 30	10R - 10M 10R - 20M	24
					± 200	± 10; ± 15; ± 20 + 0 / - 30	R47 - 10M R47 - 20M	24
CRCW1210TR	1210	3225	0.33	200	± 200	± 15	10R - 4M7	24
CRCW2010TR	2010	5025	0.5	200	± 200	± 15	10R - 4M7	24
CRCW2512TR	2512	6332	1.0	200	± 200	± 15	10R - 4M7	24

- Power rating depends on the max. temperature at the solder point, the component placement density and the substrate material
- Values from R10 to R43 with TC500 on request
- Marking: no marking on device, on label only
- Packaging: see appropriate catalog or web page
- Tolerance + 0 ... - 10% and ± 15% for D10 to D25 on request

TECHNICAL SPECIFICATIONS

PARAMETER	UNIT	D10TR CRCW0402TR	D11TR CRCW0603TR	D12TR CRCW0805TR	D25TR CRCW1206TR	CRCW1210TR	CRCW2010TR	CRCW2512TR
Rated Dissipation at 70°C (CECC 40401 EIA 575)	W	0.063	0.1	0.125	0.25	0.33	0.5	1.0
Limiting Element Voltage ²⁾	V _≡	50	75	150	200	200	200	200
Insulation Voltage (1 min)	V _{peak}	75	100	200	300	300	300	300
Thermal Resistance ¹⁾	K/W	≤ 870 ¹⁾	≤ 550 ¹⁾	≤ 440 ¹⁾	≤ 220 ¹⁾	≤ 140 ³⁾	≤ 88 ³⁾	≤ 65 ³⁾
Insulation Resistance	Ω	> 10 ⁹						
Category Temperature Range	°C	- 55 to + 125 (+ 155)						
Weight / 1000pcs	g	0.65	2	5.5	10	16	29.5	40.5

¹⁾ Measuring conditions in acc. to CECC 40401-802

²⁾ Rated voltage: $\sqrt{P \times R}$

³⁾ Depending on solder pad dimensions



DIMENSIONS

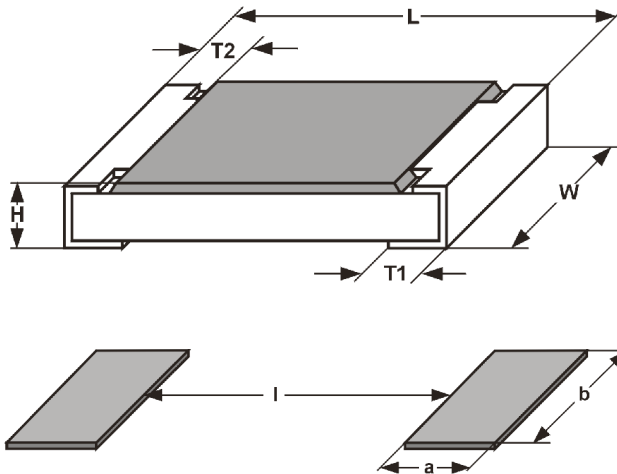

SIZE		DIMENSIONS [in millimeters]				
INCH	METRIC	L	W	H	T1	T2
0402	1005	1.0 ± 0.05	0.5 ± 0.05	0.35 ± 0.05	0.25 ^{+0.05} / _{-0.10}	0.2 ± 0.1
0603	1608	1.55 ^{+0.10} / _{-0.05}	0.85 ± 0.1	0.45 ± 0.05	0.3 ^{+0.20} / _{-0.10}	0.3 ± 0.2
0805	2012	2.0 ^{+0.20} / _{-0.10}	1.25 ± 0.15	0.45 ± 0.05	0.3 ^{+0.20} / _{-0.10}	0.3 ± 0.2
1206	3216	3.2 ^{+0.10} / _{-0.20}	1.6 ± 0.15	0.55 ± 0.05	0.45 ± 0.2	0.4 ± 0.2
1210	3225	3.2 ± 0.2	2.5 ± 0.2	0.55 ± 0.05	0.45 ± 0.2	0.4 ± 0.2
2010	5025	5.0 ± 0.15	2.5 ± 0.15	0.6 ± 0.05	0.6 ± 0.25	0.6 ± 0.25
2512	6332	6.3 ± 0.2	3.15 ± 0.15	0.6 ± 0.05	0.6 ± 0.25	0.6 ± 0.25

SIZE		SOLDER PAD DIMENSIONS [in millimeters]					
INCH	METRIC	REFLOW SOLDERING			WAVE		
		a	b	l	a	b	l
0402	1005	0.4	0.6	0.5			
0603	1608	0.5	0.9	1.0	0.9	0.9	1.0
0805	2012	0.7	1.3	1.2	0.9	1.3	1.3
1206	3216	0.9	1.7	2.0	1.1	1.7	2.3
1210	3225	0.9	2.5	2.0	1.1	2.5	2.2
2010	5025	1.0	2.5	3.9	1.2	2.5	3.9
2512	6332	1.0	3.2	5.2	1.2	3.2	5.2

PART NUMBER AND PRODUCT DESCRIPTION

PART NUMBER: D120805IB2509KP0

D 1 2 0 8 0 5 I B 2 5 0 9 K P 0

MODEL/SIZE D100402 D110603 D120805 D251206	SPECIAL CHARACTER I = Customer Trimmable	T.C. B = ± 100 ppm/K A = ± 200 ppm/K	VALUE 3 digit value 1 digit multiplier MULTIPLIER 7 = *10 ⁻³ 2 = *10 ² 8 = *10 ⁻² 3 = *10 ³ 9 = *10 ⁻¹ 4 = *10 ⁴ 0 = *10 ⁰ 5 = *10 ⁵ 1 = *10 ¹ 6 = *10 ⁶	TOLERANCE K = ± 10 % L = ± 15 % M = ± 20 % 3 = 0 % / - 30 %	PACKING P0 P5 PN B5 BN PZ	SPECIAL up to 2 digits
---	--	---	--	--	--	----------------------------------

PRODUCT DESCRIPTION: D12TR 100 25R 10% P5

D12TR MODEL D10TR D11TR D12TR D25TR	100 TC ± 100 ppm/K ± 200 ppm/K	25R RESISTANCE VALUE 49K9 = 49.9KΩ 5R1 = 5.1Ω	10 % TOLERANCE ± 10 % ± 15 % ± 20 % + 0 % / - 30 %	P5 PACKING ¹⁾ P0 P5 PN B5 BN PZ
---	--	---	--	--

PART NUMBER: CRCW080525R0KKTATR

C R C W 0 8 0 5 2 5 R 0 K K T A T R

MODEL/SIZE CRCW0402 CRCW0603 CRCW0805 CRCW1206 CRCW1210 CRCW2010 CRCW2512	VALUE R = Decimal K = Thousand M = Million	TOLERANCE K = ± 10 % L = ± 15 % M = ± 20 % W = + 0 %, - 30%	T.C. K = ± 100 ppm/K N = ± 200 ppm/K	PACKING TA = RT1 TB = RT5 TC = RT6 TD = RT7 TE = RF4 TF = R02 TG = R67 TH = R82	SPECIAL up to 2 digits TR = Customer Trimmable
---	--	--	---	--	---

PRODUCT DESCRIPTION: CRCWTR 0805 250 K 100 RT1

CRCW0805TR MODEL CRCW0402TR CRCW0603TR CRCW0805TR CRCW1206TR CRCW1210TR CRCW2010TR CRCW2512TR	250 RESISTANCE VALUE 250 = 25R 392 = 3k9 105 = 1M0 ± 5 % = 2 sig.digits, plus multiplier	K TOLERANCE K = ± 10 % L = ± 15 % M = ± 20 % W = + 0 %, - 30%	100 T.C. ± 100 ppm/K ± 200 ppm/K	RT1 PACKING ¹⁾ RT1 RF4 RT5 R02 RT6 R67 RT7 R82
--	--	---	--	---

NOTE: 1) Please refer to table PACKING, page 3.

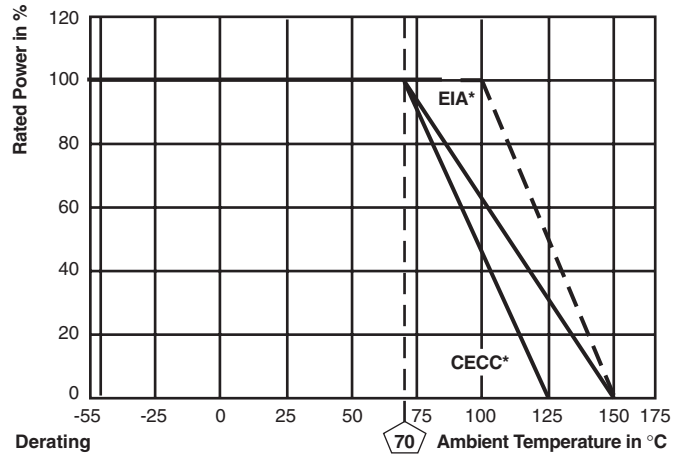
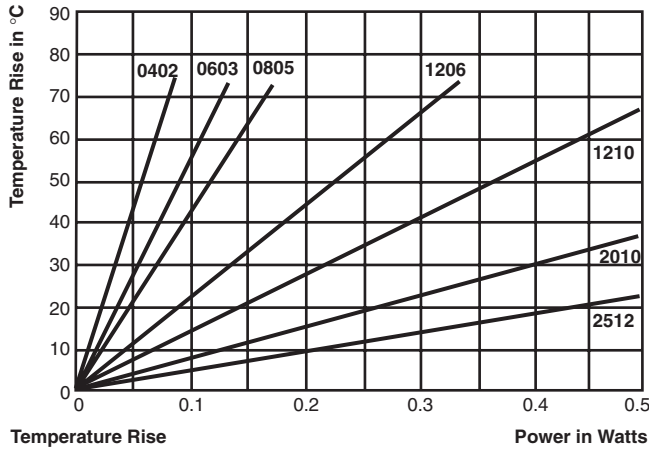

PACKING					
MODEL	REEL				
	TAPE WIDTH	DIAMETER	PIECES/REEL	PACKING CODE	
				PAPER ¹⁾	BLISTER ¹⁾
D10TR CRCW0402TR	8mm	180mm/7"	10 000	P0/RT7	
		330mm/13"	50 000	PZ/RF4	
D11TR CRCW0603TR	8mm	180mm/7"	5 000	P5/RT1	
		255mm/10"	10 000	P0/RT5	B5/na BN/na
		330mm/13"	20 000	PN/RT6	
D12TR CRCW0805TR	8mm	180mm/7"	5 000	P5/RT1	
		255mm/10"	10 000	P0/RT5	B5/na BN/na
		330mm/13"	20 000	PN/RT6	
D25TR CRCW1206TR	8mm	180mm/7"	5 000	P5/RT1	
		255mm/10"	10 000	P0/RT5	B5/na BN/na
		330mm/13"	20 000	PN/RT6	
CRCW1210TR	8mm	180mm/7"	5 000	P5/RT1	B5/na
		330mm/13"	20 000	PN/RT6	BN/na
CRCW2010TR	12mm	180mm/7"	4 000		R02
CRCW2512TR	12mm	180mm/7"	2 000		R67
			4 000		R82

¹⁾ European / N. American packing codes

• Further information about packing: see appropriate catalog or web page

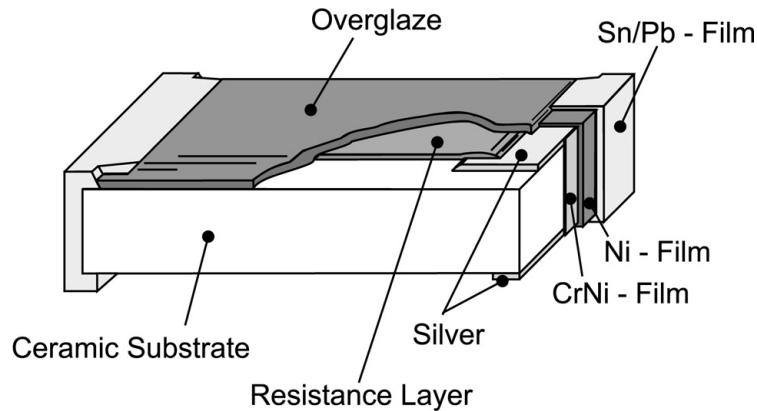
Trimming Instructions:

YAG-Laser:

The trimming length should not exceed 50% of the dimension W (width)

Maximum trimming factor = 1.6

Distance between end termination and trimming cut = 0.2mm min

Double cut: Distance between two cuts = 0.5mm min

The laser-cut should be protected with epoxy resins

PERFORMANCE					
TEST	CONDITIONS OF TEST	REQUIREMENTS IN %			
		0402 0603	0805 1206 1210	2010 2512	
Endurance Test at 70°C IEC 60115-1 4.25.1	1000 hours at 70°C, 1.5 hours "ON", 0.5 hours "OFF"	≤ ± 1.0	≤ ± 0.5	≤ ± 1.0	
Endurance at UCT IEC 60115-1 4.25.3	1000 hours at 125°C without load	≤ ± 1.0	≤ ± 0.5	≤ ± 1.0	
Overload Test IEC 60115-1 4.13	Short time overload	≤ ± 0.5	≤ ± 0.25	≤ ± 0.5	
Thermal Shock IEC 60115-1 4.19; IEC 60068-2-14;	Rapid change between upper and lower category temperature	≤ ± 0.5	≤ ± 0.25	≤ ± 0.5	
Damp Heat Steady State IEC 60115-1 4.24; IEC 60068-2-3	56 days at 40°C and 93% relative humidity	≤ ± 0.25	≤ ± 0.5	≤ ± 1.0	
Resistance to Soldering Heat IEC 60115-1 4.18; IEC 60068-2-20	10 seconds at 260°C solder bath temperature	≤ ± 0.5	≤ ± 0.25	≤ ± 0.5	

1) Limits for change of resistance at test. Data are valid for the non trimmed resistors only. Depending on trimming process some properties can change

APPLICABLE SPECIFICATIONS
<ul style="list-style-type: none"> • CECC40000 / 40400 / 40401-802 • EN140400 / IEC 60115 – 1 • EIA 575 • MIL-PRF-55342



Notice

Specifications of the products displayed herein are subject to change without notice. Vishay Intertechnology, Inc., or anyone on its behalf, assumes no responsibility or liability for any errors or inaccuracies.

Information contained herein is intended to provide a product description only. No license, express or implied, by estoppel or otherwise, to any intellectual property rights is granted by this document. Except as provided in Vishay's terms and conditions of sale for such products, Vishay assumes no liability whatsoever, and disclaims any express or implied warranty, relating to sale and/or use of Vishay products including liability or warranties relating to fitness for a particular purpose, merchantability, or infringement of any patent, copyright, or other intellectual property right.

The products shown herein are not designed for use in medical, life-saving, or life-sustaining applications. Customers using or selling these products for use in such applications do so at their own risk and agree to fully indemnify Vishay for any damages resulting from such improper use or sale.