

Dual operational transconductance amplifier

NE5517/5517A

DESCRIPTION

The NE5517 contains two current-controlled transconductance amplifiers, each with a differential input and push-pull output. The NE5517 offers significant design and performance advantages over similar devices for all types of programmable gain applications. Circuit performance is enhanced through the use of linearizing diodes at the inputs which enable a 10dB signal-to-noise improvement referenced to 0.5% THD. The NE5517 is suited for a wide variety of industrial and consumer applications and is recommended as the preferred circuit in the Dolby[®] HX (Headroom Extension) system.

Constant impedance buffers on the chip allow general use of the NE5517. These buffers are made of Darlington transistor and a biasing network which changes bias current in dependence of I_{ABC} .

Therefore, changes of output offset voltages are almost eliminated. This is an advantage of the NE5517 compared to LM13600. With the LM13600, a burst in the bias current I_{ABC} guides to an audible offset voltage change at the output. With the constant impedance buffers of the NE5517 this effect can be avoided and makes this circuit preferable for high quality audio applications.

FEATURES

- Constant impedance buffers
- ΔV_{BE} of buffer is constant with amplifier IBIAS change
- Pin compatible with LM13600
- Excellent matching between amplifiers
- Linearizing diodes
- High output signal-to-noise ratio

PIN CONFIGURATION

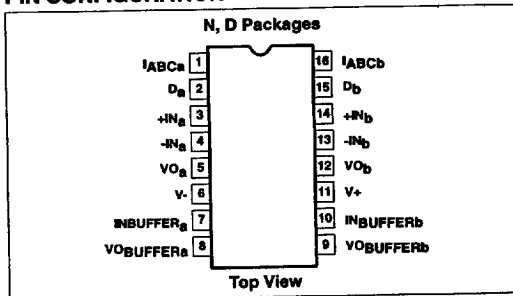

APPLICATIONS

- Multiplexers
- Timers
- Electronic music synthesizers
- Dolby[™] HX Systems
- Current-controlled amplifiers, filters
- Current-controlled oscillators, impedances

Dolby is a registered trademark of Dolby Laboratories Inc., San Francisco, Calif.

PIN DESIGNATION

PIN NO.	SYMBOL	NAME AND FUNCTION
1	I_{ABC}	Amplifier bias input A
2	D	Diode bias A
3	+IN	Non-inverting input A
4	-IN	Inverting input A
5	V_O	Output A
6	V-	Negative supply
7	INBUFFER	Buffer input A
8	VOBUFFER	Buffer output A
9	VOBUFFER	Buffer output B
10	INBUFFER	Buffer input B
11	V+	Positive supply
12	V_O	Output B
13	-IN	Inverting input B
14	+IN	Non-inverting input B
15	D	Diode bias B
16	I_{ABC}	Amplifier bias input B

7110826 0078446 173

Dual operational transconductance amplifier

NE5517/5517A

CIRCUIT SCHEMATIC

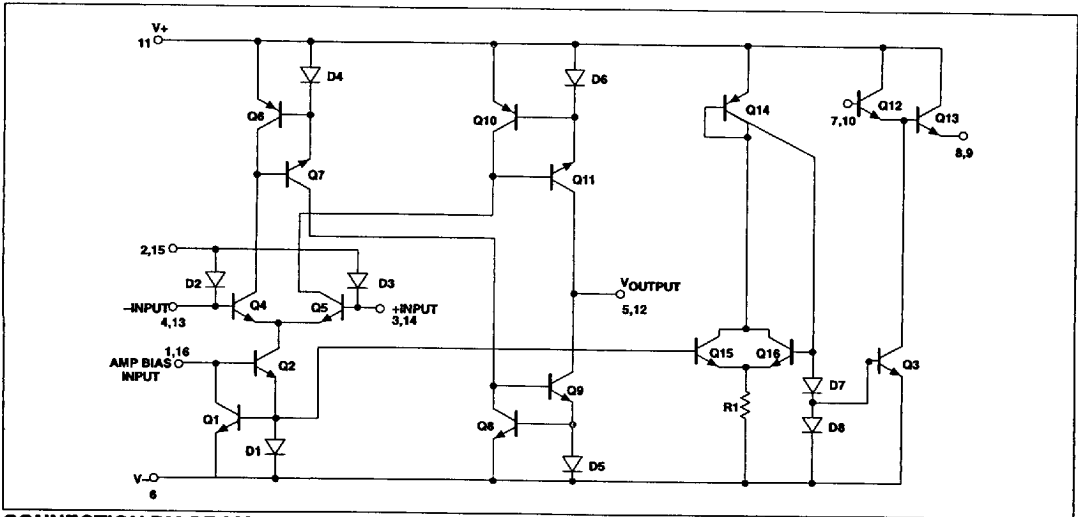

CONNECTION DIAGRAM

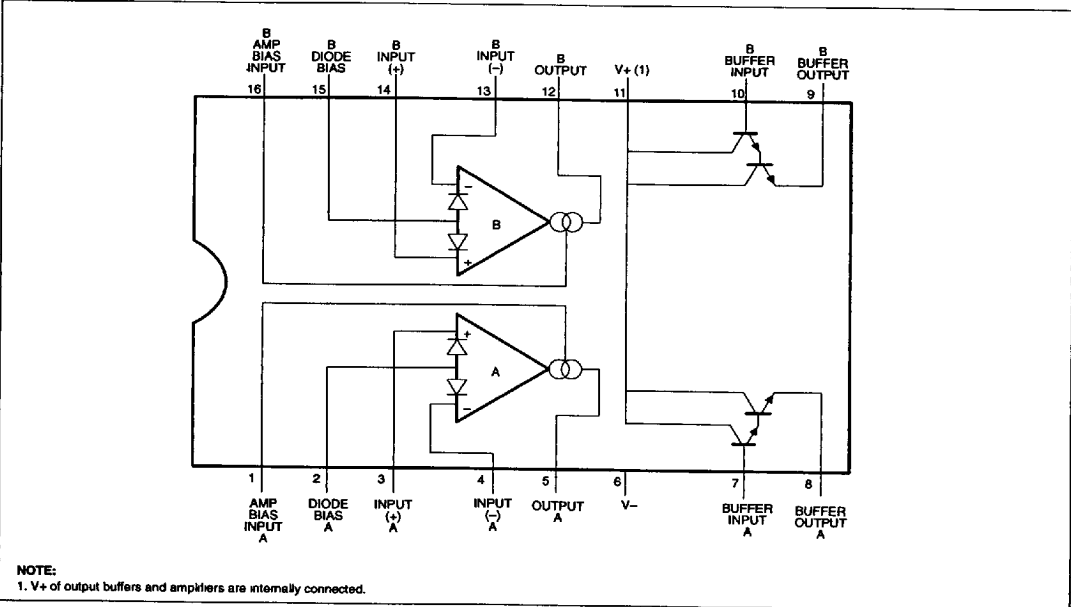

Dual operational transconductance amplifier

NE5517/5517A

ORDERING INFORMATION

DESCRIPTION	TEMPERATURE RANGE	ORDER CODE	DWG #
16-Pin Plastic Dual In-Line Package (DIP)	0 to +70°C	NE5517N	0406C
16-Pin Plastic Dual In-Line Package (DIP)	0 to +70°C	NE5517AN	0406C
16-Pin Small Outline (SO) Package	0 to +70°C	NE5517D	0005D

ABSOLUTE MAXIMUM RATINGS

SYMBOL	PARAMETER	RATING	UNIT
V _S	Supply voltage ¹	36 V _{DC} or ±18	V
	NE5517 NE5517A	44 V _{DC} or ±22	V
P _D	Power dissipation, T _A =25°C (still air) ²	1500	mW
	NE5517N, NE5517AN	1125	mW
	NE5517D		
V _{IN}	Differential input voltage	±5	V
I _D	Diode bias current	2	mA
I _{ABC}	Amplifier bias current	2	mA
I _{SC}	Output short-circuit duration	Indefinite	
I _{OUT}	Buffer output current ³	20	mA
T _A	Operating temperature range NE5517N, NE5517AN	0°C to +70	°C
V _{DC}	DC input voltage	+V _S to -V _S	
T _{STG}	Storage temperature range	-65°C to +150°C	°C
T _{SOLD}	Lead soldering temperature (10sec max)	300	°C

NOTES:

- For selections to a supply voltage above ±22V, contact factory
- The following derating factors should be applied above 25°C
N package at 12.0mW/°C
N package at 12.0mW/°C
D package at 9.0mW/°C
- Buffer output current should be limited so as to not exceed package dissipation.

DC ELECTRICAL CHARACTERISTICS¹

SYMBOL	PARAMETER	TEST CONDITIONS	NE5517			NE5517A			UNIT
			Min	Typ	Max	Min	Typ	Max	
V _{OS}	Input offset voltage	Over temperature range I _{ABC} 5μA		0.4	5		0.4	2	mV
				0.3	5		0.3	2	mV
		ΔV _{OS} /ΔT	Avg. TC of input offset voltage		7			7	
	V _{OS} including diodes	Diode bias current (I _D)=500μA		0.5	5		0.5	2	mV
V _{OS}	Input offset change	5μA ≤ I _{ABC} ≤ 500μA		0.1			0.1	3	mV
I _{OS}	Input offset current	Avg. TC of input offset current		0.1	0.6		0.1	0.6	μA
				0.001			0.001		μA/°C
I _{BIAS}	Input bias current	Over temperature range		0.4	5		0.4	5	μA
				1	8		1	7	μA
	ΔI _B /ΔT	Avg. TC of input current		0.01			0.01		μA/°C
g _M	Forward transconductance	Over temperature range	6700	9600	13000	7700	9600	12000	μmho
			5400			4000			
	g _M tracking			0.3			0.3		dB
I _{OUT}	Peak output current	R _L =0, I _{ABC} =5μA		5		3	5	7	μA
		R _L =0, I _{ABC} =500μA	350	500	650	350	500	650	μA
		R _L =0,	300			300			μA

■ 7110826 0078448 T46 ■

Dual operational transconductance amplifier

NE5517/5517A

DC ELECTRICAL CHARACTERISTICS¹ (continued)

SYMBOL	PARAMETER	TEST CONDITIONS	NE5517			NE5517A			UNIT
			Min	Typ	Max	Min	Typ	Max	
V _{OUT}	Peak output voltage								
	Positive	R _L =∞, 5μA ≤ I _{ABC} ≤ 500μA	+12	+14.2		+12	+14.2		V
	Negative	R _L =∞, 5μA ≤ I _{ABC} ≤ 500μA	-12	-14.4		-12	-14.4		V
I _{CC}	Supply current	I _{ABC} =500μA, both channels		2.6	4		2.6	4	mA
	V _{OS} sensitivity								
	Positive	Δ V _{OS} /Δ V ₊		20	150		20	150	μV/V
	Negative	Δ V _{OS} /Δ V ₋		20	150		20	150	μV/V
CMRR	Common-mode rejection ratio		80	110		80	110		dB
	Common-mode range		±12	±13.5		±12	±13.5		V
	Crosstalk	Referred to input ² 20Hz < f < 20kHz		100			100		dB
I _{IN}	Differential input current	I _{ABC} =0, input=±4V		0.02	100		0.02	10	nA
	Leakage current	I _{ABC} =0 (Refer to test circuit)		0.2	100		0.2	5	nA
R _{IN}	Input resistance		10	26		10	26		kΩ
B _W	Open-loop bandwidth			2			2		MHz
SR	Slew rate	Unity gain compensated		50			50		V/μs
I _N _{BUFFER}	Buff. input current	5		0.4	5		0.4	5	μA
V _O _{BUFFER}	Peak buffer output voltage	5	10			10			V
	ΔV _{BE} of buffer	Refer to Buffer V _{BE} test ³ circuit		0.5	5		0.5	5	mV

NOTES:

- These specifications apply for V_S=±15V, T_A=25°C, amplifier bias current (I_{ABC})=500μA, Pins 2 and 15 open unless otherwise specified. The inputs to the buffers are grounded and outputs are open.
- These specifications apply for V_S=±15V, I_{ABC}=500μA, R_{OUT}=5kΩ connected from the buffer output to -V_S and the input of the buffer is connected to the transconductance amplifier output.
- V_S=±15, R_{OUT}=5kΩ connected from Buffer output to -V_S and 5μA ≤ I_{ABC} ≤ 500μA.

Dual operational transconductance amplifier

NE5517/5517A

TYPICAL PERFORMANCE CHARACTERISTICS

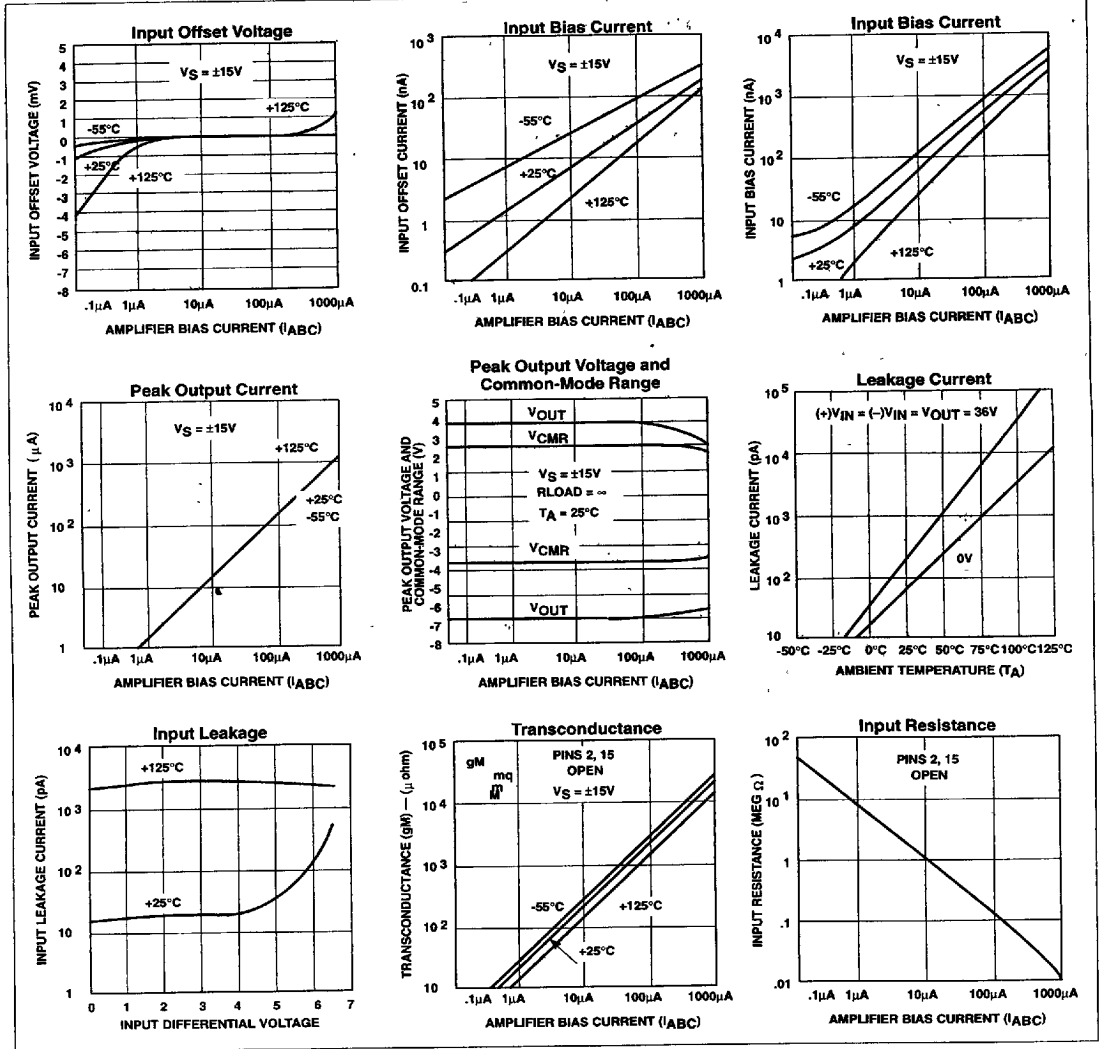

Dual operational transconductance amplifier

NE5517/5517A

TYPICAL PERFORMANCE CHARACTERISTICS (Continued)

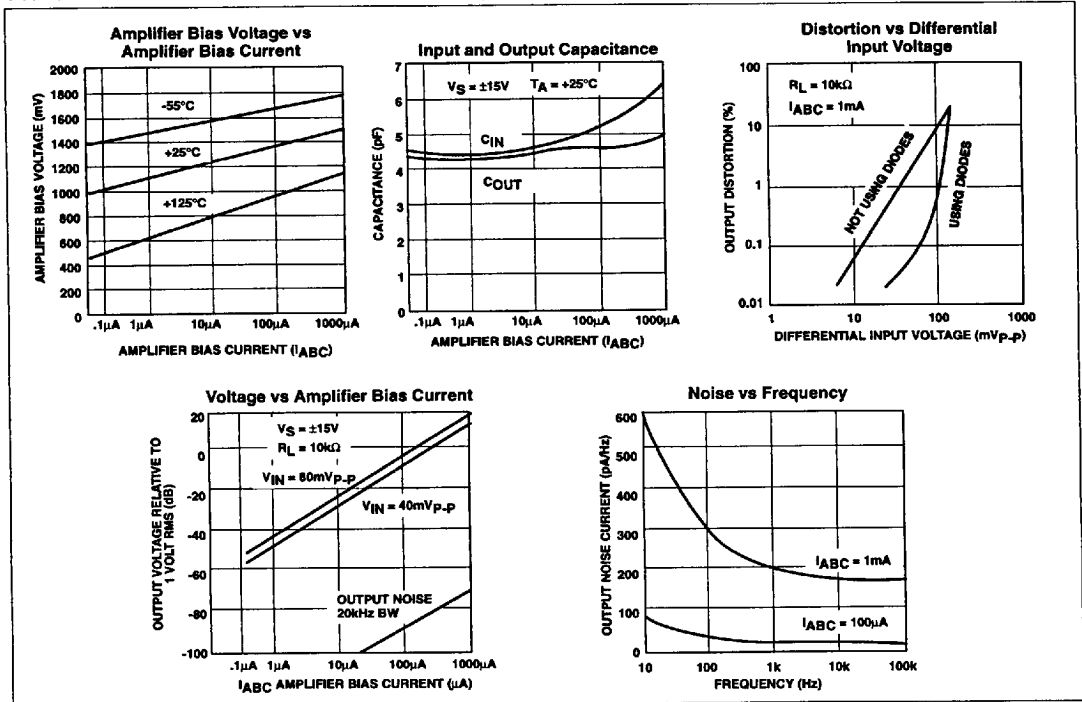

Dual operational transconductance amplifier

NE5517/5517A

TYPICAL PERFORMANCE CHARACTERISTICS (Continued)

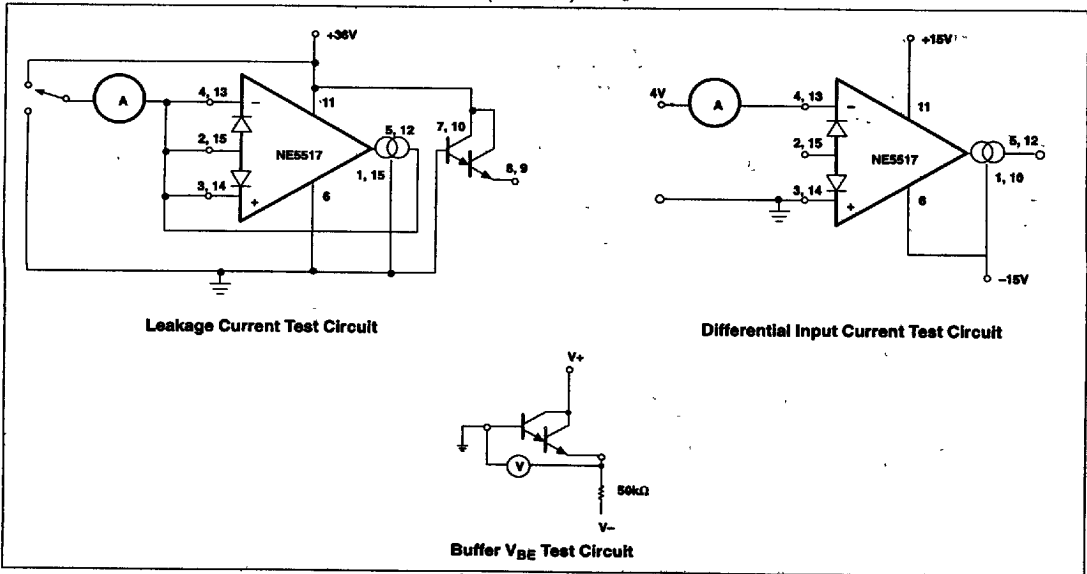

APPLICATIONS

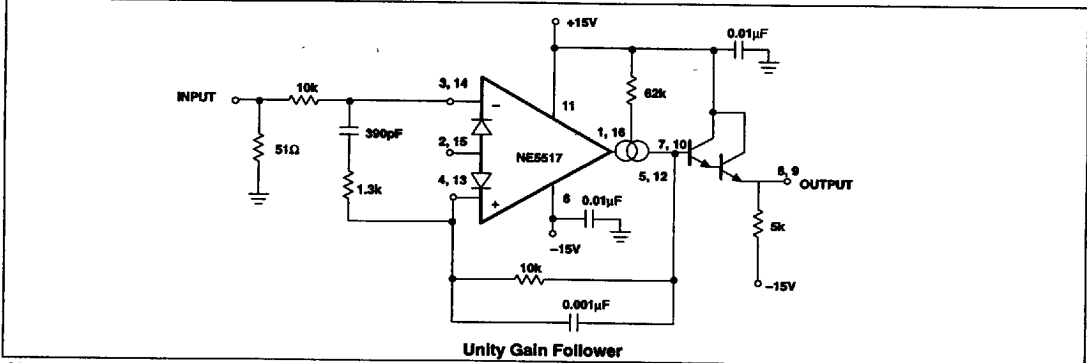

CIRCUIT DESCRIPTION

The circuit schematic diagram of one-half of the NE5517, a dual operational transconductance amplifier with linearizing diodes and impedance buffers, is shown in Figure 1.

1. Transconductance Amplifier

The transistor pair, Q₄ and Q₅, forms a transconductance stage. The ratio of their collector currents (I₄ and I₅, respectively) is defined by the differential input voltage, V_{IN}, which is shown in equation 1.

$$V_{IN} = \frac{KT}{q} \ln \frac{I_5}{I_4} \quad (1)$$

Where V_{IN} is the difference of the two input voltages

$$KT \cong 26\text{mV at room temperature (300}^\circ\text{K)}.$$

Transistors Q₁, Q₂ and diode D₁ form a current mirror which focuses the sum of current I₄ and I₅ to be equal to amplifier bias current I_B:

$$I_4 + I_5 = I_B \quad (2)$$

If V_{IN} is small, the ratio of I₅ and I₄ will approach unity and the Taylor series of ln function can be approximated as

$$\frac{KT}{q} \ln \frac{I_5}{I_4} \approx \frac{KT}{q} \frac{I_5 - I_4}{I_4} \quad (3)$$

Dual operational transconductance amplifier

NE5517/5517A

and $I_4 \approx I_5 \approx I_B$

$$\frac{KT}{q} \ln \frac{I_5}{I_4} \approx \frac{KT}{q} \ln \frac{I_5 - I_4}{1/2 I_B} = \frac{2KT}{q} \ln \frac{I_5 - I_4}{I_B} = V_{IN}^{(4)}$$

$$I_5 - I_4 = V_{IN} \frac{(I_B)^q}{2KT}$$

The remaining transistors (Q₆ to Q₁₁) and diodes (D₄ to D₆) form three current mirrors that produce an output current equal to I₅ minus I₄. Thus:

$$V_{IN} \left(I_B \frac{q}{2KT} \right) = I_O \tag{5}$$

The term $\frac{(I_B)^q}{2KT}$ is then the transconductance

of the amplifier and is proportional to I_B.

2. Linearizing Diodes

For V_{IN} greater than a few millivolts, equation 3 becomes invalid and the transconductance increases non-linearly. Figure 2 shows how the internal diodes can linearize the transfer function of the operational amplifier. Assume D₂ and D₃ are biased with current sources and the input signal current is I_S. Since

$I_4 + I_5 = I_B$ and $I_5 - I_4 = I_O$, that is:

$$I_4 = (I_B - I_O), I_5 = (I_B + I_O)$$

For the diodes and the input transistors that have identical geometries and are subject to similar voltages and temperatures, the following equation is true:

$$\frac{I}{q} \ln \frac{I_D + I_S}{I_D - I_S} = \frac{KT}{q} \ln \frac{1/2(I_B + I_O)}{1/2(I_B - I_O)} \tag{6}$$

$$I_O = I_S \frac{2I_B}{I_D} \text{ for } |I_S| < \frac{I_D}{2}$$

The only limitation is that the signal current should not exceed I_D.

3. Impedance Buffer

The upper limit of transconductance is defined by the maximum value of I_B (2mA). The lowest value of I_B for which the amplifier will function therefore determines the overall dynamic range. At low values of I_B, a buffer with very low input bias current is desired. A Darlington amplifier with constant-current source (Q₁₄, Q₁₅, Q₁₆, D₇, D₈, and R₁) suits the need.

APPLICATIONS

Voltage-Controlled Amplifier

In Figure 3, the voltage divider R₂, R₃ divides the input-voltage into small values (mV range) so the amplifier operates in a linear manner.

It is:

$$I_{OUT} = -V_{IN} \cdot \frac{R_3}{R_2 + R_3} \cdot gM;$$

$$V_{OUT} = I_{OUT} \cdot R_L;$$

$$A = \frac{V_{OUT}}{V_{IN}} = \frac{R_3}{R_2 + R_3} \cdot gM \cdot R_L$$

$$(3) gM = 19.2 I_{ABC}$$

(gM in μmhos for I_{ABC} in mA)

Since gM is directly proportional to I_{ABC}, the amplification is controlled by the voltage V_C in a simple way.

When V_C is taken relative to -V_{CC} the following formula is valid:

$$I_{ABC} = \frac{(V_C - 1.2V)}{R_1}$$

The 1.2V is the voltage across two base-emitter baths in the current mirrors. This circuit is the base for many applications of the NE5517.

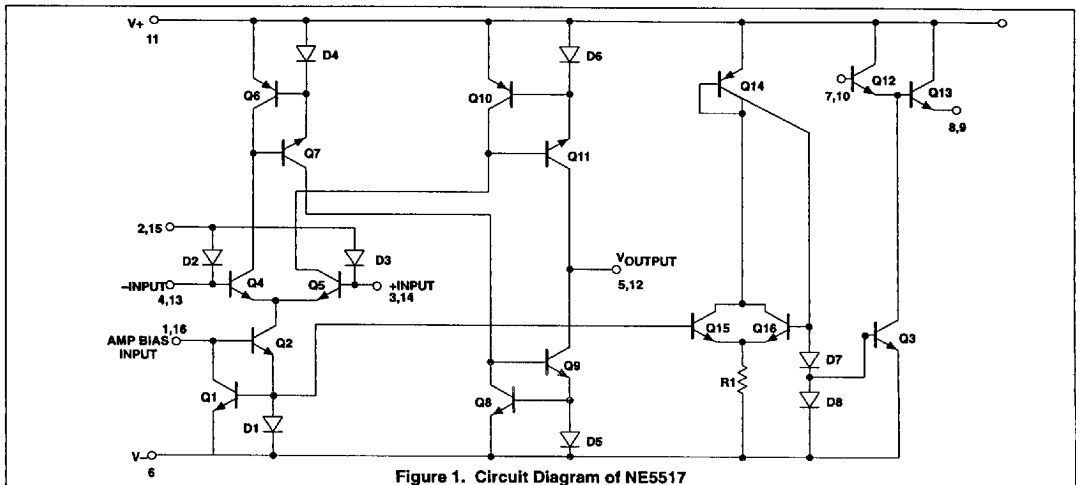

Figure 1. Circuit Diagram of NE5517

Dual operational transconductance amplifier

NE5517/5517A

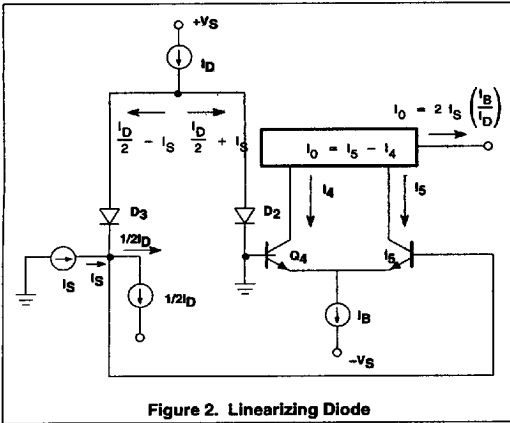

Figure 2. Linearizing Diode

Stereo Amplifier With Gain Control

Figure 4 shows a stereo amplifier with variable gain via a control input. Excellent tracking of typical 0.3dB is easy to achieve. With the potentiometer, R_B , the offset can be adjusted. For AC-coupled amplifiers, the potentiometer may be replaced with two 510Ω resistors.

Modulators

Because the transconductance of an OTA (Operational Transconductance Amplifier) is directly proportional to I_{ABC} , the amplification of a signal can be controlled easily. The output current is the product from transconductance × input voltage. The circuit is effective up to approximately 200kHz. Modulation of 99% is easy to achieve.

Voltage-Controlled Resistor (VCR)

Because an OTA is capable of producing an output current proportional to the input voltage, a voltage variable resistor can be made. Figure 6 shows how this is done. A voltage presented at the R_X terminals forces a voltage at the input. This voltage is multiplied by g_M and thereby forces a current through the R_X terminals:

$$R_X = \frac{R + R_A}{g_M + R_A}$$

where g_M is approximately 19.21 μMHOs at room temperature. Figure 7 shows a Voltage Controlled Resistor using linearizing diodes. This improves the noise performance of the resistor.

Voltage-Controlled Filters

Figure 8 shows a Voltage Controlled Low-Pass Filter. The circuit is a unity gain buffer until X_C/g_M is equal to R/R_A . Then, the frequency response rolls off at a 6dB per octave with the -3dB point being defined by the given equations. Operating in the same manner, a Voltage Controlled High-Pass Filter is shown in Figure 9. Higher order filters can be made using additional amplifiers as shown in Figures 10 and 11.

Voltage-Controlled Oscillators

Figure 12 shows a voltage-controlled triangle-square wave generator. With the indicated values a range from 2Hz to 200kHz is possible by varying I_{ABC} from 1mA to 10μA.

The output amplitude is determined by $I_{OUT} \times R_{OUT}$.

Please notice the differential input voltage is not allowed to be above 5V.

With a slight modification of this circuit you can get the sawtooth pulse generator, as shown in Figure 13.

APPLICATION HINTS

To hold the transconductance g_M within the linear range, I_{ABC} should be chosen not greater than 1mA. The current mirror ratio should be as accurate as possible over the entire current range. A current mirror with only two transistors is not recommended. A suitable current mirror can be built with a PNP transistor array which causes excellent matching and thermal coupling among the transistors. The output current range of the DAC normally reaches from 0 to -2mA. In this application, however, the current range is set through R_{REF} (10kΩ) to 0 to -1mA.

$$I_{DACMAX} = 2 \cdot \frac{V_{REF}}{R_{REF}} = 2 \cdot \frac{5V}{10k} = 1mA$$

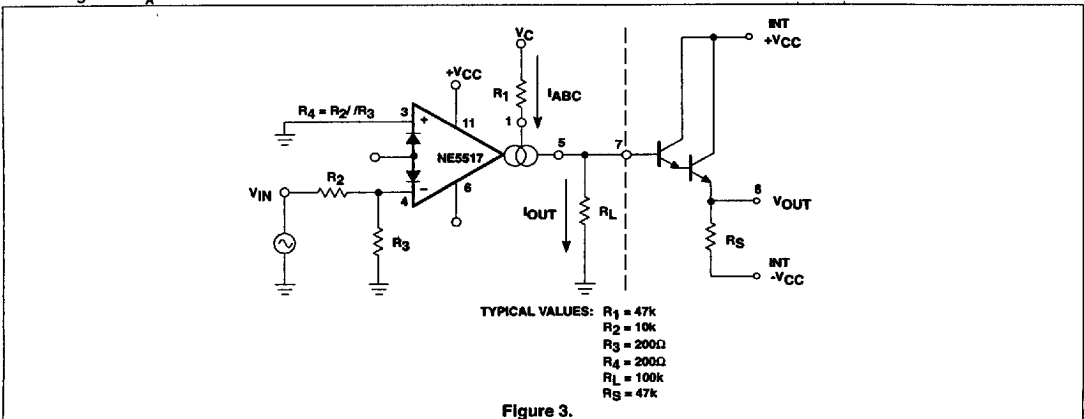

Figure 3.

TYPICAL VALUES: $R_1 = 47k$
 $R_2 = 10k$
 $R_3 = 200\Omega$
 $R_4 = 200\Omega$
 $R_L = 100k$
 $R_S = 47k$

Dual operational transconductance amplifier

NE5517/5517A

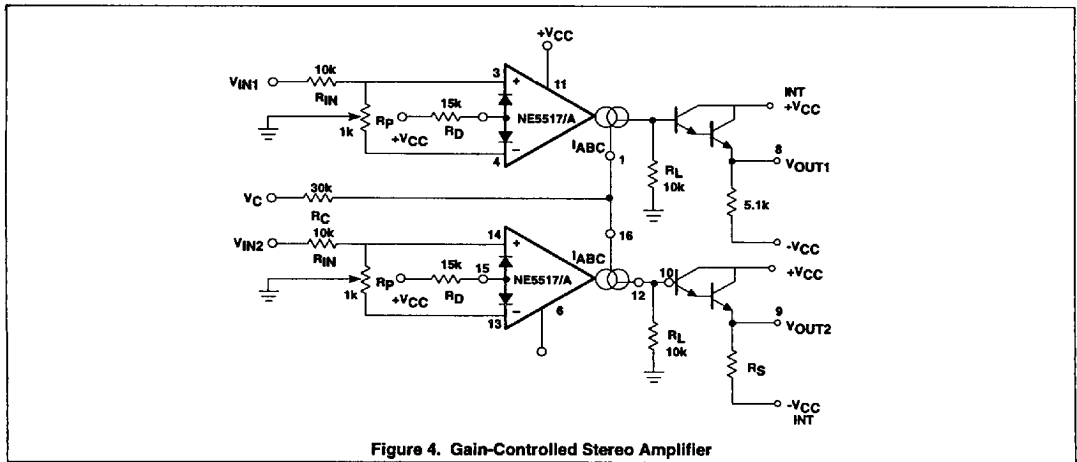

Figure 4. Gain-Controlled Stereo Amplifier

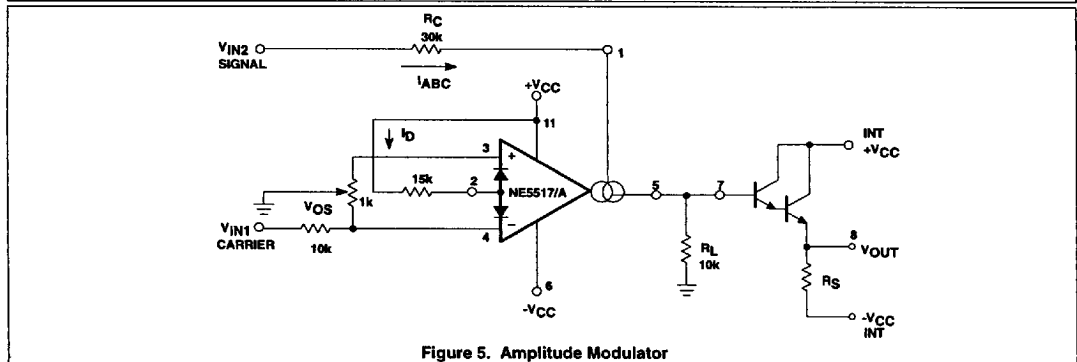
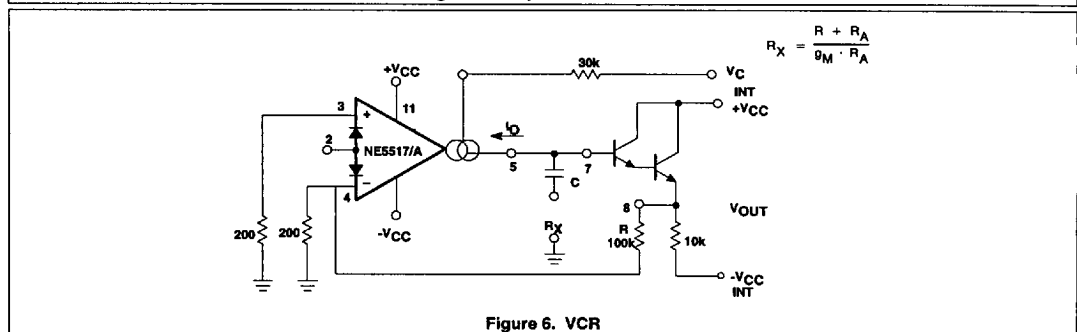

Figure 5. Amplitude Modulator



$$R_x = \frac{R + R_A}{9M \cdot R_A}$$

Figure 6. VCR

Dual operational transconductance amplifier

NE5517/5517A

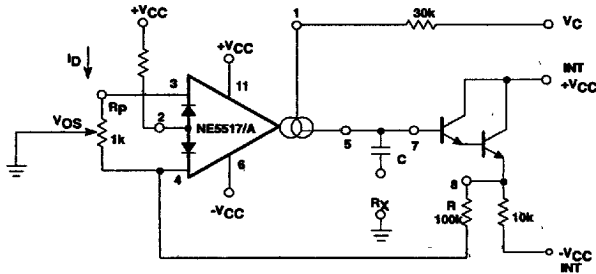
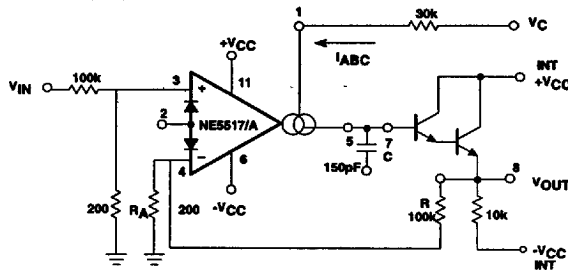

Figure 7. VCR with Linearizing Diodes



NOTE:

$$f_o = \frac{R_A g_M}{g(R + R_A) 2\pi C}$$

Figure 8. Voltage-Controlled Low-Pass Filter

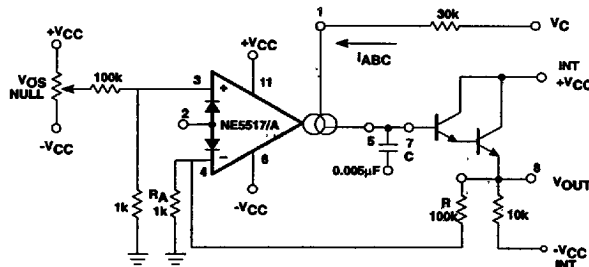

NOTE:

$$f_o = \frac{R_A g_M}{g(R + R_A) 2\pi C}$$

Figure 9. Voltage-Controlled High-Pass Filter

Dual operational transconductance amplifier

NE5517/5517A

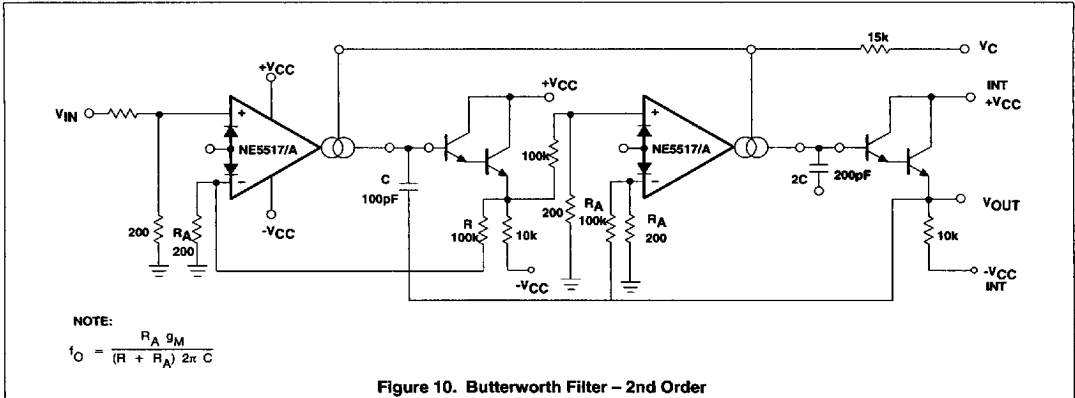

Figure 10. Butterworth Filter - 2nd Order

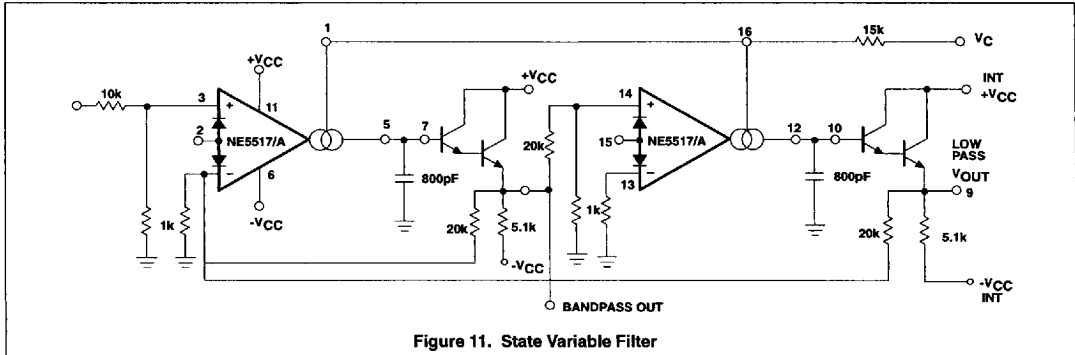

Figure 11. State Variable Filter

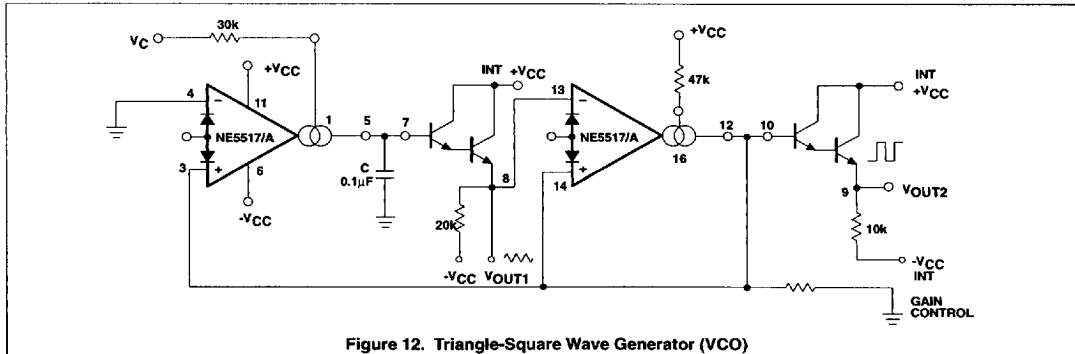

Figure 12. Triangle-Square Wave Generator (VCO)

Dual operational transconductance amplifier

NE5517/5517A

